

SONY®

LARGE LENS ADAPTOR

HDLA1500

HDLA1505

LARGE VIEWFINDER ADAPTOR

HDLA1507

OPERATION MANUAL English
1st Edition

WARNING

To reduce the risk of fire or electric shock, do not expose this apparatus to rain or moisture.

To avoid electrical shock, do not open the cabinet. Refer servicing to qualified personnel only.

AVERTISSEMENT

Afin de réduire les risques d'incendie ou d'électrocution, ne pas exposer cet appareil à la pluie ou à l'humidité.

Afin d'écartier tout risque d'électrocution, garder le coffret fermé. Ne confier l'entretien de l'appareil qu'à un personnel qualifié.

WARNUNG

Um die Gefahr von Bränden oder elektrischen Schlägen zu verringern, darf dieses Gerät nicht Regen oder Feuchtigkeit ausgesetzt werden.

Um einen elektrischen Schlag zu vermeiden, darf das Gehäuse nicht geöffnet werden. Überlassen Sie Wartungsarbeiten stets nur qualifiziertem Fachpersonal.

For the customers in the U.S.A.

This equipment has been tested and found to comply with the limits for a Class A digital device, pursuant to Part 15 of the FCC Rules. These limits are designed to provide reasonable protection against harmful interference when the equipment is operated in a commercial environment. This equipment generates, uses, and can radiate radio frequency energy and, if not installed and used in accordance with the instruction manual, may cause harmful interference to radio communications. Operation of this equipment in a residential area is likely to cause harmful interference in which case the user will be required to correct the interference at his own expense.

You are cautioned that any changes or modifications not expressly approved in this manual could void your authority to operate this equipment.

All interface cables used to connect peripherals must be shielded in order to comply with the limits for a digital device pursuant to Subpart B of Part 15 of FCC Rules.

For the customers in Europe

This product with the CE marking complies with both the EMC Directive and the Low Voltage Directive issued by the Commission of the European Community.

Compliance with these directives implies conformity to the following European standards:

- EN60950-1: Product Safety
- EN55103-1: Electromagnetic Interference (Emission)
- EN55103-2: Electromagnetic Susceptibility (Immunity)

This product is intended for use in the following Electromagnetic Environments:

E1 (residential), E2 (commercial and light industrial), E3 (urban outdoors), E4 (controlled EMC environment, ex. TV studio).

The manufacturer of this product is Sony Corporation, 1-7-1 Konan, Minato-ku, Tokyo, Japan.

The Authorized Representative for EMC and product safety is Sony Deutschland GmbH, Hedelfinger Strasse 61, 70327 Stuttgart, Germany. For any service or guarantee matters please refer to the addresses given in separate service or guarantee documents.

Pour les clients en Europe

Ce produit portant la marque CE est conforme à la fois à la Directive sur la compatibilité électromagnétique (EMC) et à la Directive sur les basses tensions émises par la Commission de la Communauté Européenne.

La conformité à ces directives implique la conformité aux normes européennes suivantes:

- EN60950-1 : Sécurité des produits
- EN55103-1 : Interférences électromagnétiques (émission)
- EN55103-2 : Sensibilité électromagnétique (immunité)

Ce produit est prévu pour être utilisé dans les environnements électromagnétiques suivants : E1 (résidentiel), E2 (commercial et industrie légère), E3 (urbain extérieur) et E4 (environnement EMC contrôlé, ex. studio de télévision).

Le fabricant de ce produit est Sony Corporation, 1-7-1 Konan, Minato-ku, Tokyo, Japon.

Le représentant autorisé pour EMC et la sécurité des produits est Sony Deutschland GmbH, Hedelfinger Strasse 61, 70327 Stuttgart, Allemagne. Pour toute question concernant le service ou la garantie, veuillez consulter les adresses indiquées dans les documents de service ou de garantie séparés.

Für Kunden in Europa

Dieses Produkt besitzt die CE-Kennzeichnung und erfüllt die EMV-Richtlinie sowie die Niederspannungsrichtlinie der EG-Kommission.

Angewandte Normen:

- EN60950-1: Sicherheitsbestimmungen
- EN55103-1: Elektromagnetische Verträglichkeit (Störaussendung)
- EN55103-2: Elektromagnetische Verträglichkeit (Störfestigkeit)

Für die folgenden elektromagnetischen Umgebungen:

E1 (Wohnbereich), E2 (kommerzieller und in beschränktem Maße industrieller Bereich), E3 (Stadtbereich im Freien) und E4 (kontrollierter EMV-Bereich, z.B. Fernsehstudio).

Der Hersteller dieses Produkts ist Sony Corporation, 1-7-1
Konan, Minato-ku, Tokyo, Japan.
Der autorisierte Repräsentant für EMV und Produktsicherheit
ist Sony Deutschland GmbH, Hedelfinger Strasse 61, 70327
Stuttgart, Deutschland. Bei jeglichen Angelegenheiten in
Bezug auf Kundendienst oder Garantie wenden Sie sich bitte
an die in den separaten Kundendienst- oder
Garantiedokumenten aufgeführten Anschriften.

Table of Contents

Foreword	5
Model-Distinction Labels Used in This Manual	5
Overview	5
Principal Differences Among the Models	5
Features.....	5
System Configuration	6
Precautions	8
Locations and Functions of Parts	9
Side Panel	9
Rear Panel.....	11
Control Panel	12
Installation	14
Preparations with the Camera (HDLA1500/1505).....	14
Preparations with the Adaptor	14
Mounting the Camera in the Adaptor	15
Attaching a Large Viewfinder (HDLA1500/1507)	18
Attaching a Large Studio Lens (HDLA1500/1505)	20
Mounting on the Tripod.....	21
Connecting the Camera Cables	21
Attaching the Number Plates.....	21
Specifications	22

Foreword

Model-Distinction Labels Used in This Manual

Indications of functions specific to particular models

This manual describes three models of the HDLA1500 series: the HDLA1500 and HDLA1505 Large Lens Adaptors, and the HDLA1507 Large Viewfinder Adaptor. The differences in shapes, functions, and operations among models are clarified with the model names in the text or the following model-distinction labels:

1500

Text or figures applicable to the HDLA1500

1505

Text or figures applicable to the HDLA1505

1507

Text or figures applicable to the HDLA1507

Text and figures for which there is no such labels apply in common to all three models.

Overview

The HDLA1500-series adaptors are designed to enable mounting a large lens for studio use and/or a large viewfinder to a portable-type HD Color Camera, such as HDC1400/1400R, HDC1450/1450R, HDC1500/1500R, HDC1550/1550R, HDC3300/3300R and HSC-300. The HDLA1500/1505 Large Lens Adaptor, in combination with a viewfinder among various types, allows the camera to be fitted with a large lens of high magnification, yielding high-speed controllability for system camera operations in studios or on relay mobiles. The HDLA1507 Large Viewfinder Adaptor accepts a portable camera on which a lens has been mounted so that it can be used in combination with a large viewfinder.

Principal Differences Among the Models

The mountable lens and viewfinder depends on the model.

		HDLA1500	HDLA1505	HDLA1507
Lens	Large lens for studio use	Can be attached to the lens mount on the front panel	Can be attached to the lens mount on the front panel	—
	Portable lens	—	—	Can be used mounted on the camera as-is
Viewfinder	Large type (e.g. HDVF-700A, HDVF-EL100)	Can be mounted on the table of the rear upper block	—	Can be mounted on the table of the rear upper block
	Small type (e.g. HDVF-550, HDVF-C730W, HDVF-C950W)	—	Can be used mounted on the camera as-is	—

Features

Compatible with large lenses of Sony specifications

1500 **1505**

The adaptor allows you to attach Sony hanger-type large lenses. It is compatible with both full servo-controlled and manually controlled lenses.

Instant Docking Mechanism

The camera can be mounted with no cable connections and no adjustments. Signal, power and control interface

between the camera and the adaptor are achieved via a special connector located on the bottom of the camera without the need for any cable. The special mechanism that requires no adjustment is employed also for connection of a lens.

Independent lens attachment/detachment

To make transportation and storage easy, you can attach/detach the lens only, leaving the camera mounted in the adaptor.

Compatible with large viewfinders

1500 1507

The HDVF-700A (7-inch monochrome) or HDVF-EL100 (11-inch color) can be attached to the viewfinder table. With the mechanism to slide the position of the viewfinder forward and back, the portable camera in the adaptor can have the same total longitudinal size as that of the HDC1000/1000R, a large camera for studio use, permitting you to readily use the portable camera as if it were a studio-use camera.

Control panel of the studio-use camera type

The control panel on the rear panel provides functions equivalent to those of the HDC1000/1000R video camera for studio use. It allows you to operate the portable camera in this adaptor as you would a studio camera.

System Configuration

Peripherals and related devices for the HDLA1500 series are shown in the figures.

Note

Production of some of the peripherals and related devices shown in the figures has been discontinued.

For advice on choosing devices, please contact your Sony dealer or a Sony sales representative.

HDLA1500

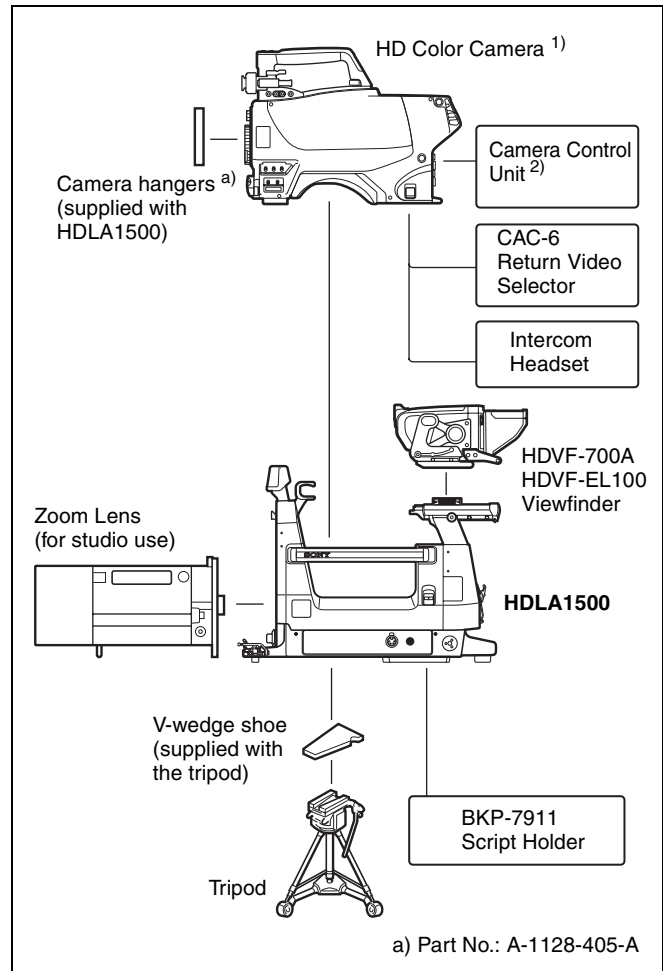

1) HDC1400/1400R, HDC1450/1450R, HDC1500/1500R, HDC1550/1550R, HDC3300/3300R, HSC-300

2) HDCU1000/1500/3300/3300R, HSCU-300

HDLA1505

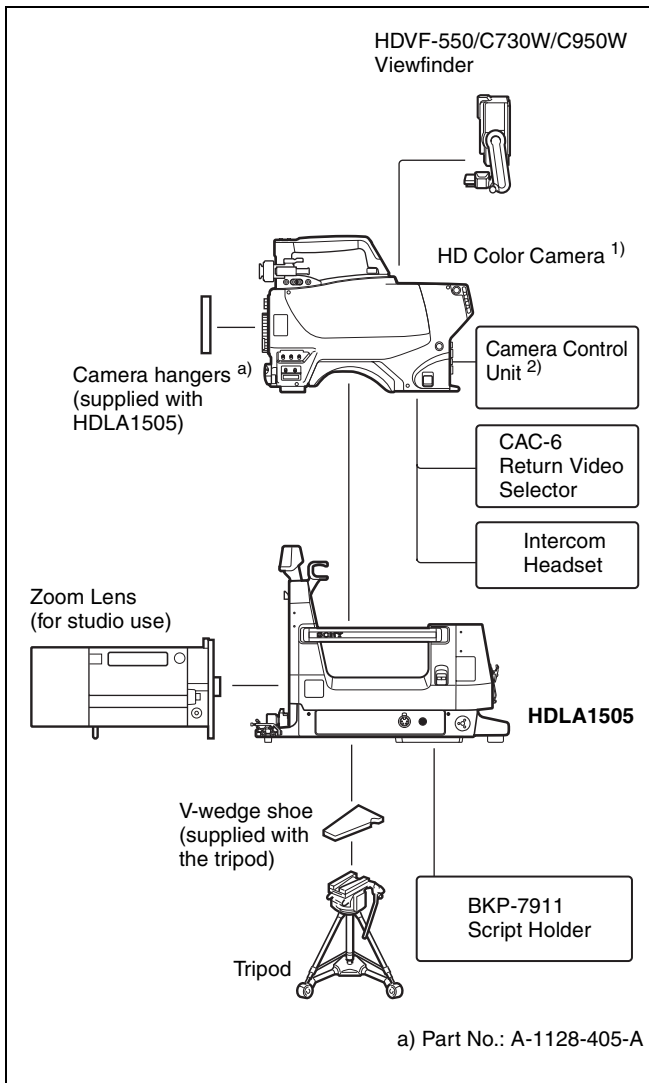

- 1) HDC1400/1400R, HDC1450/1450R, HDC1500/1500R, HDC1550/1550R, HDC3300/3300R, HSC-300
 2) HDCU1000/1500/3300/3300R, HSCU-300

HDLA1507

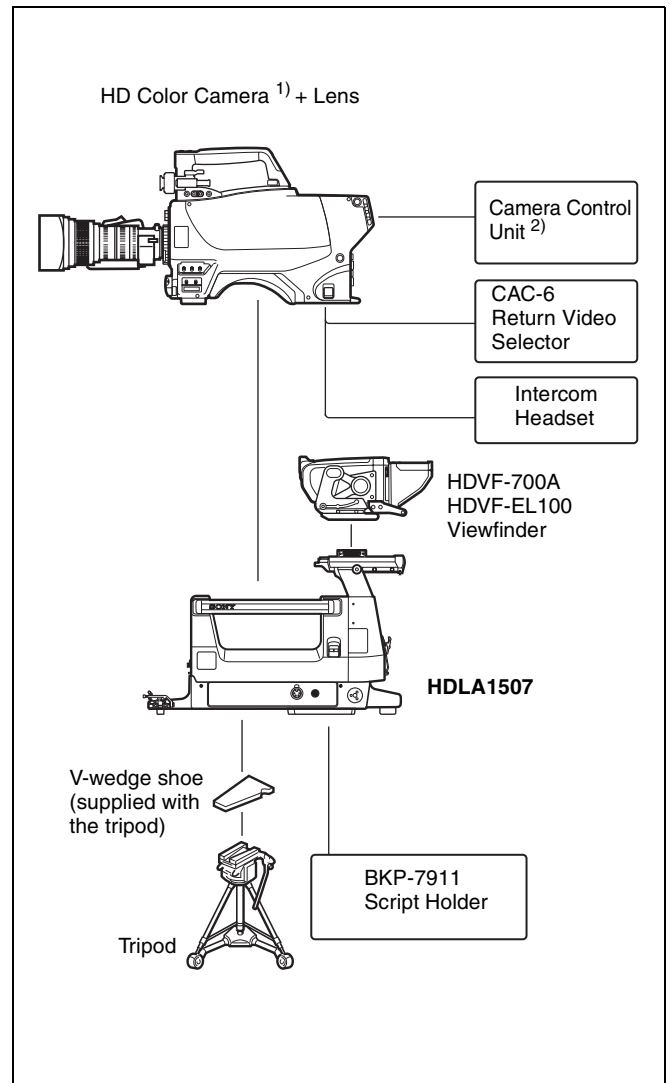

- 1) HDC1400/1400R, HDC1450/1450R, HDC1500/1500R, HDC1550/1550R, HDC3300/3300R, HSC-300
 2) HDCU1000/1500/3300/3300R, HSCU-300

Precautions

Do not subject to severe shocks

Damage to the case or internal components may result.

Operation and storage environment

Store in a level place with air conditioning.

Avoid use or storage in the following places:

- Extremely hot or cold places
- Places with high humidity
- Places with strong vibration
- Near strong magnetic fields
- In places where it receives much direct sunlight, or near heating equipment

Condensation

If you move the camera from a very cold place to a warm place, or use it in a damp location, condensation may form on the lens or inside the camera.

The camera has no built-in condensation indicator. If you find condensation on the body or lens, switch the camera off and wait for the condensation to disappear for about one hour.

Locations and Functions of Parts

Side Panel

HDLA1500

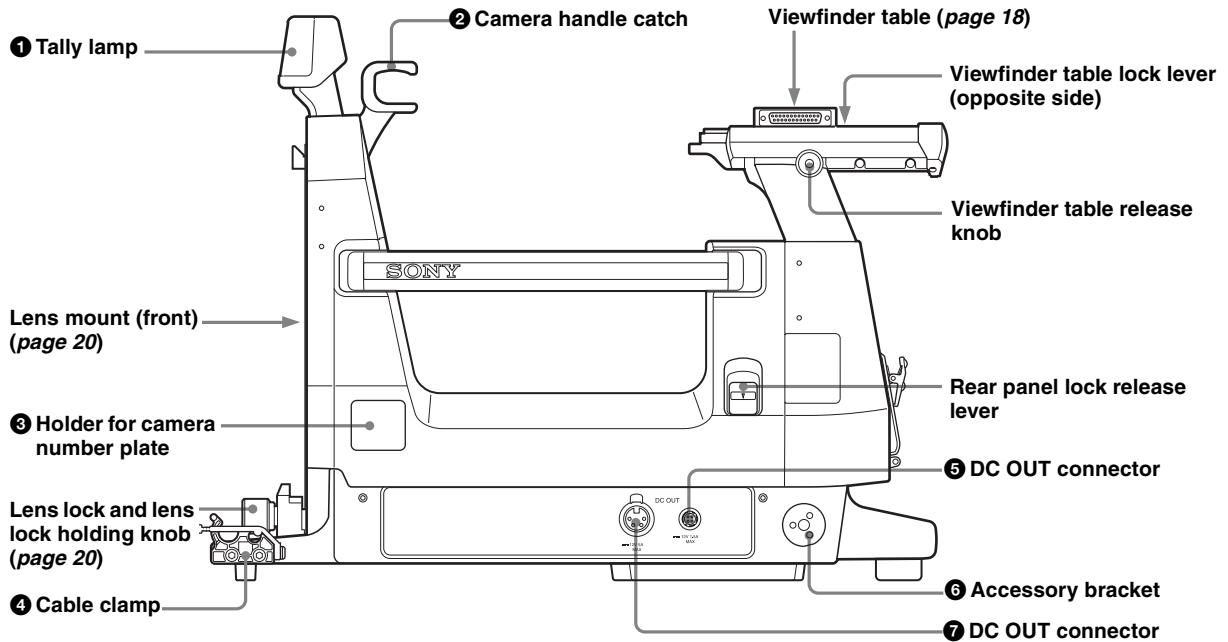

HDLA1505

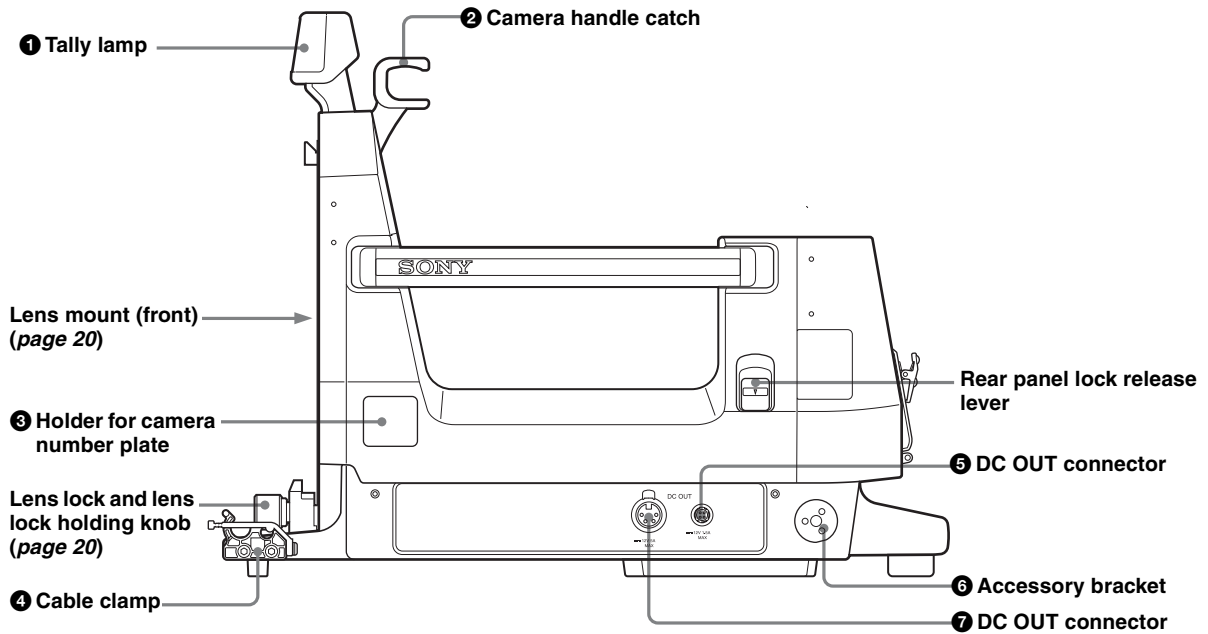

HDLA1507

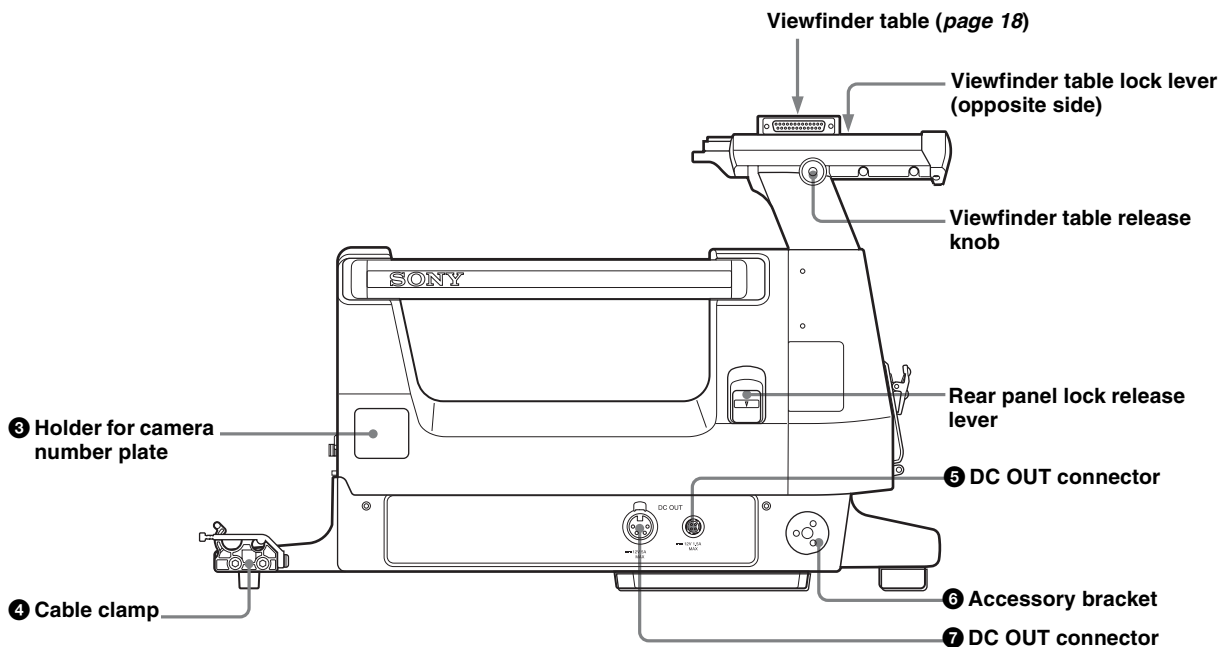

1 Tally lamp [1500] [1505]

The lamp lights when a red tally signal is supplied to the mounted camera.

To display the camera number, attach the supplied number plate for up tally or select the desired number on the menu of the camera.

2 Camera handle catch [1500] [1505]

To hold the camera handle when the viewfinder is to be shifted toward the front.

For details, see "To adjust the viewfinder position" on page 19.

3 Holder for camera number plate

Attach a number plate for side panel (supplied) to display the camera number.

For details, see "Attaching the Number Plates" on page 21.

4 Cable clamp

Used to secure the camera cable.

5 DC OUT connector (round 4-pin)

To supply power (12 V, max. 1.5 A ¹⁾) to the script light of the BKP-7911 Script Holder.

1) Limited depending on the conditions, such as the cable length between the camera and CCU, and the type of CCU, viewfinder or lens used in combination.

6 Accessory bracket

Used to secure optional accessories such as the BKP-7911 Script Holder.

For more information on attaching an accessory, see the accessory's operation manual.

7 DC OUT connector (XLR 4-pin)

To supply general-purpose power (12 V, max. 5 A ¹⁾).

1) Limited depending on the conditions, such as the cable length between the camera and CCU, and the type of CCU, viewfinder or lens used in combination.

Rear Panel

HDLA1500

Control panel
(page 12)

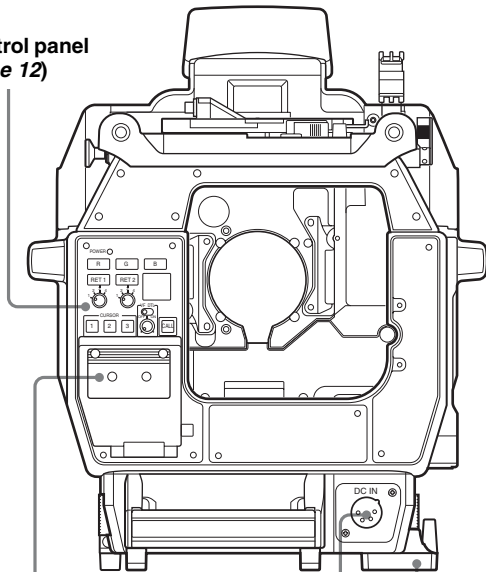

① Memo clip

② DC IN connector

③ Cable hanger

HDLA1507

Control panel
(page 12)

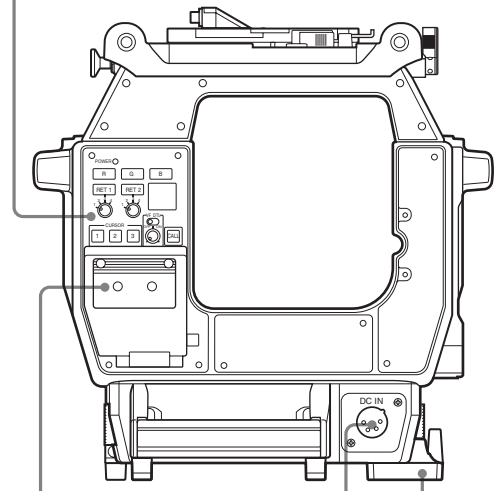

① Memo clip

② DC IN connector

③ Cable hanger

HDLA1505

Control panel
(page 12)

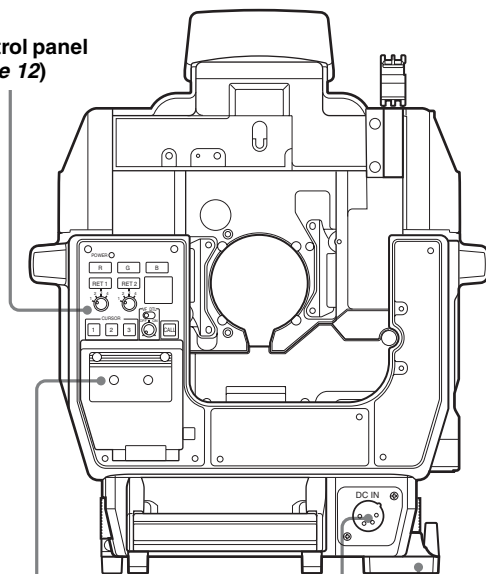

① Memo clip

② DC IN connector

③ Cable hanger

① Memo clip

To hold scratch paper, etc.
Open it to access the control panel.

② DC IN connector (4-pin)

When the mounted camera is used in stand-alone status without a camera control panel, connect power (10.5 to 17 V) for this adaptor here in addition to the power to the camera.

Note

In stand-alone status, power supply from this unit is limited to 6.5 A. Check the power consumption of the device to be connected.

③ Cable hanger

To hang the camera cable.

Control Panel

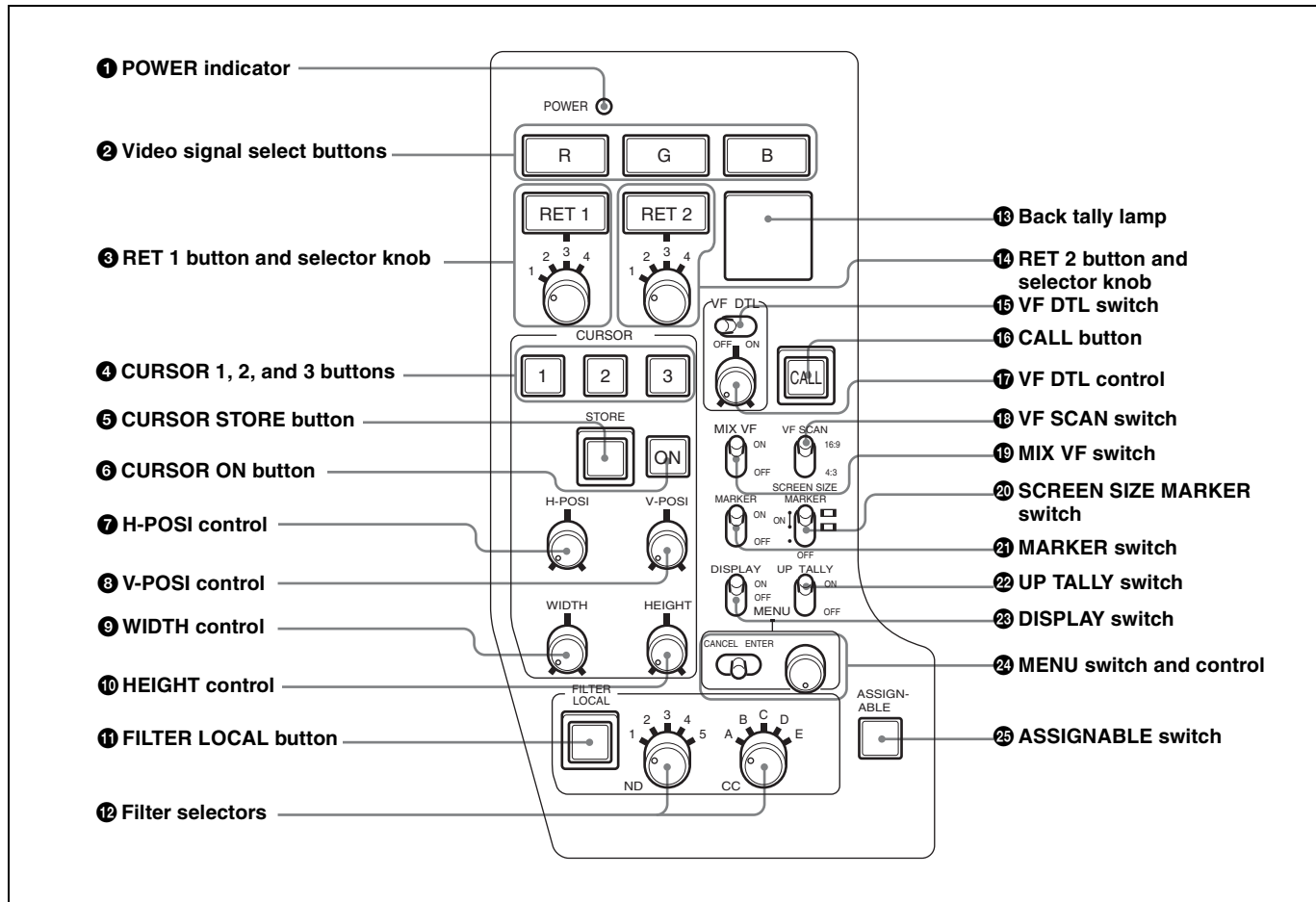

1 POWER indicator

This indicator lights up or goes dark as follows to indicate the power supply status of the camera:

Green: Power is being supplied to the camera.

Red: Power is being supplied to the camera, but the CAM PW button of the MSU-900/950 Master Setup Unit or RCP-700/900-series Remote Control Panel is set to OFF.

Yellow: Power is being supplied to the camera, but the VF PW button of the MSU-900/950 Master Setup Unit or RCP-700/900-series Remote Control Panel is set to OFF, and power is not being supplied to the viewfinder.

Off: Power is not being supplied to the camera.

2 Video signal select buttons

Select the video output signal (R, G, or B) to the viewfinder.

The R, G, and B buttons may be pressed individually or in combination. The signal corresponding to each pressed button will be output. When two buttons are pressed, the output will consist of those two signals mixed together. When all three buttons are pressed, the output to the viewfinder will be the Y signal.

When no buttons is pressed, the output will be a color signal if the viewfinder is a color model, and it will be the Y signal if the viewfinder is a monochrome model. The video output to the monitor connected to the TEST OUT connector of the camera will also depend on the setting of these buttons (however, this output is in monochrome in all situations).

3 RET 1 button and selector knob

You may select from among the four return signals from the CCU, using the selector knob.

By pressing the button, you can view the return video signal selected by the selector knob, on the viewfinder screen. Pressing the button again will switch the viewfinder screen display and monitor output back to the camera's video signal.

4 CURSOR (cursor memory) 1, 2, and 3 buttons

Used to store the size and position of the box cursor to be displayed on the viewfinder screen.

Three different box cursor settings can be stored in memory using buttons 1, 2, and 3. Pressing one of these buttons will cause a cursor of the respective stored size and position to be displayed.

Note

When one of the CURSOR buttons is lit, the H-POSI, V-POSI, WIDTH, and HEIGHT buttons do not function.

5 CURSOR STORE button

Press this button to store the size and position of the box cursor in memory.

Note

If the CURSOR ON button is not lit, box cursor information will not be stored.

6 CURSOR ON button

When this button is pressed, the button will light up and the box cursor will be displayed on the viewfinder screen.

When the button is pressed again, the light will go off and the box cursor will disappear.

7 H-POSI (horizontal position) control

Adjust the horizontal position of the box cursor displayed on the viewfinder screen within the effective resolution area.

8 V-POSI (vertical position) control

Adjust the vertical position of the box cursor displayed on the viewfinder screen within the effective resolution area.

9 WIDTH control

Adjust the width of the box cursor displayed on the viewfinder screen within the effective resolution area.

10 HEIGHT control

Adjust the height of the box cursor displayed on the viewfinder screen within the effective resolution area.

11 FILTER LOCAL (filter local control) button

Pressing and lightening this button enables selecting of a color temperature conversion filter and ND filter using the CC filter selector and ND filter selector. Pressing the button again (it goes dark) gives control of the filters to the MSU-900/950 Master Setup Unit or RCP-700/900-series Remote Control Panel.

12 Filter selectors

When the FILTER LOCAL button is lit up, you can change the ND filter and CC (color temperature conversion) filter settings.

Turn the left selector to select an ND filter and the right selector to select a CC filter.

13 Back tally lamp

This lamp lights red when the red tally signal is supplied to the camera. When the CALL button on the MSU-900/950 Master Setup Unit or the RCP-700/900-series Remote Control Panel is pressed, the lamp lights if previously off or goes off if previously on.

You can display the camera number selected on the menu.

14 RET 2 button and selector knob

You may select from among the four return signals (1 to 4) from the CCU using the selector knob.

By pressing the button, you can view the return video signal selected by the selector knob, on the viewfinder screen. Pressing the button again will switch the viewfinder screen display and monitor output back to the camera's video signal.

Note

If both the RET 1 and RET 2 buttons are pressed, the RET 1 button takes the priority.

15 VF DTL (viewfinder detail adjustment) switch

ON: Emphasizes the contours of the image on the viewfinder screen. When the switch is set to this position, you can adjust the amount of detail using the VF DTL control.

OFF: Disables contour emphasis.

16 CALL button

- Press to call the operator of the Camera Control Unit, the MSU-900/950 Master Setup Unit, or the RCP-700/900-series Remote Control Panel connected to the camera.

When pressed, the camera's red tally lamp will light up if previously off, and turn off if previously on. The CALL button on the connected control devices will light up, and their buzzer will sound.

- When the CALL button on a connected control device is pressed, this button will light up.

17 VF DTL (viewfinder detail) control

Adjust the amount of detail of the picture on the viewfinder screen when the VF DTL switch is set to ON. This has no effect on the output signal of the camera.

18 VF (viewfinder) SCAN switch

Used to control the viewfinder screen display.

16:9: To set the viewfinder display to the 16:9 aspect ratio.

4:3: To set the viewfinder display to the 4:3 aspect ratio.

Note

This switch is enabled on the HDVF-700A only.

19 MIX VF (mixture viewfinder) switch

You can see the mixed signal of the camera's output signal and the return video signal on the viewfinder screen.

ON: This function is enabled. You can see the mixed signal of the camera's output signal and the selected return video signal on the viewfinder screen when you press the RET 1 or RET 2 button.

OFF: This function is disabled.

20 SCREEN SIZE MARKER switch

Used to control the display of the screen size marker as follows:

ON (■): Areas outside the specified ratio area will be darkened.

ON (□): The screen size marker (white lines) will be displayed.

OFF: The screen size marker will not be displayed.

21 MARKER switch

Used to control the display of the marker as follows:

ON: A marker selected from the menu will be displayed on the viewfinder screen.

OFF: The marker will not be displayed.

22 UP TALLY switch [1500] [1505]

Set whether or not the camera's Up Tally lamp and the lens' tally lamp will light when the camera receives a red tally signal.

ON: The tally lamps will light.

OFF: The tally lamps will not light.

23 DISPLAY switch

The functions of the DISPLAY switch are as follows:

ON: Text and messages describing the camera settings and operating status may be displayed on the viewfinder screen.

OFF: Status messages will not appear on the viewfinder screen.

MENU: Menus for camera settings will be displayed on the viewfinder screen.

24 MENU switch and control

Use the control to select camera's menu items or change setting values in the menus displayed on the viewfinder screen.

The functions of the switch are as follows:

ENTER: Confirm the camera's menu or page selected using the MENU control, or confirm setting values.

CANCEL: Cancel menu setting values or return to the previous menu page.

25 ASSIGNABLE switch

A function can be assigned with a camera menu operation.

Installation

Preparations with the Camera (HDLA1500/1505)

Attach the camera hangers supplied with the adaptor to the camera.

- 1 Remove the four blind bushes from the front panel.
- 2 Attach the camera hangers (supplied, Part No.: A-1128-405-A (1 pair)) and secure them to the front panel of the camera by firmly tightening the +B4×10 screws supplied with the hangers.

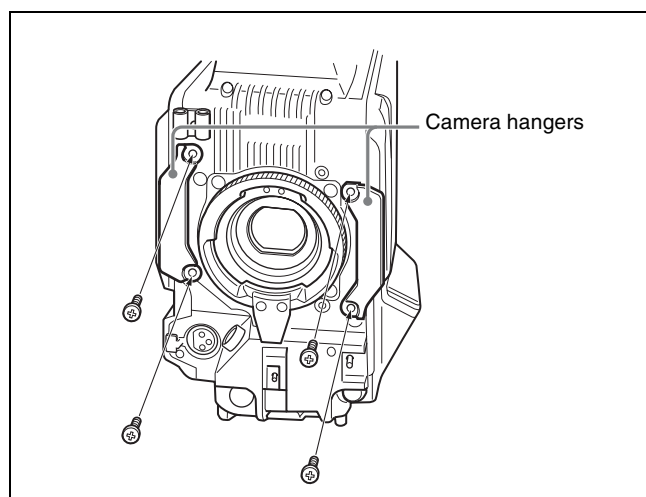

Note

Do not use any other screws than the supplied ones.

Preparations with the Adaptor

Removing the front cover [1500] [1505]

Remove the front cover.

Attaching a V-wedge shoe

If the camera is to be mounted on a tripod, first attach the V-wedge shoe (supplied with the tripod) to the adaptor.

- 1 Place the adaptor on its side on a stable stand so that you have a good view of the base.
- 2 Attach the V-wedge shoe to the base of the adaptor, using the screws supplied with the tripod.

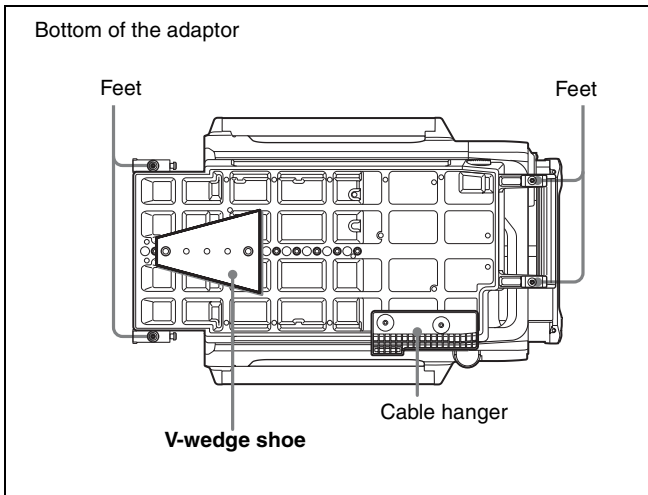

When attaching the V-wedge shoe, taking the total weight of the adaptor, camera, studio lens and viewfinder, and the size of the pan and tilt head of the tripod into consideration, choose a position such that the unit will be mounted stably on the tripod.

Note

Some tripods cannot be attached unless the feet and cable hanger are removed from the adaptor. Remove the feet and hanger to use such a tripod.

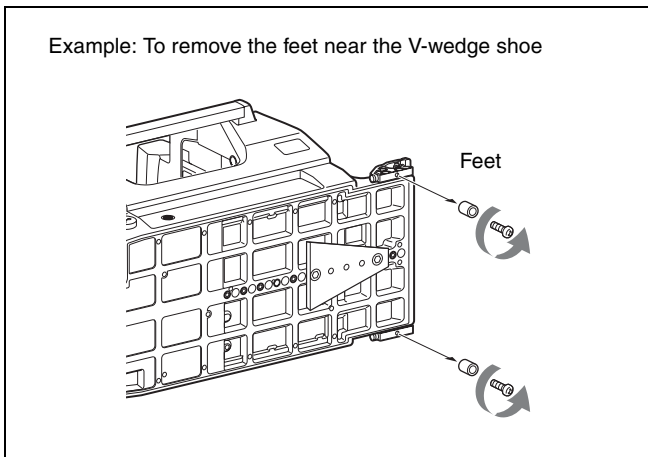

Attaching the stopper 1500 1507

For use of the HDVF-9900 viewfinder in combination, attach the stopper supplied with the adaptor to the side panel of the adaptor.

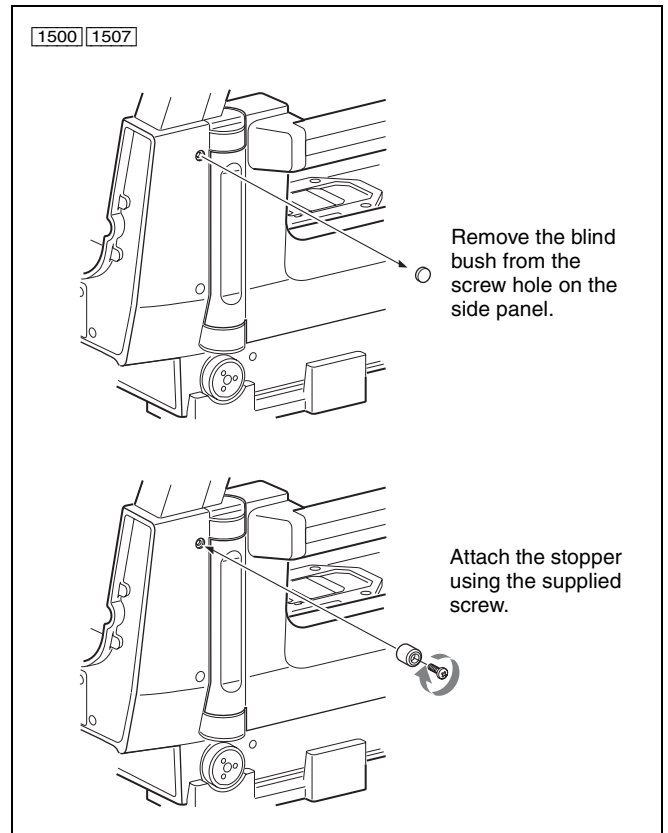

Mounting the Camera in the Adaptor

Notes

- Be sure to turn off the camera power before mounting.
- If the camera is mounted with the power ON, the protection circuit of the adaptor will be activated. In such a case, unmount the camera from the adaptor, turn off the power, wait for more than 30 seconds, then mount it again.

Mounting procedure

While the figures of the adaptors in the following steps show the states where the studio lens and the large viewfinder are not attached, the camera can also be mounted after attaching the large lens and the large viewfinder to the adaptor.

For the HDLA1507, start from step 2.

- 1 Check that the camera lock lever on the front panel is in its upper position.

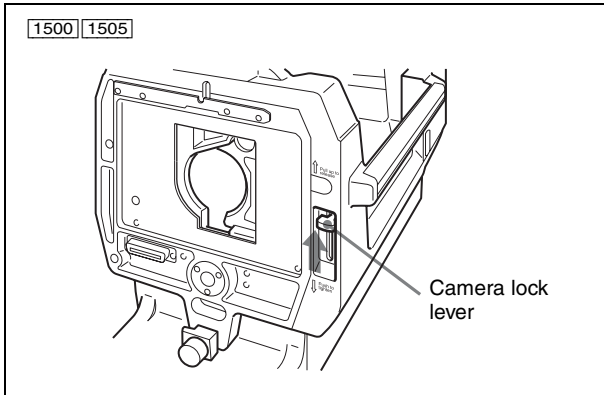

For the HDLA1500, proceed to step 2.
For the HDLA1505, proceed to step 3.

- 2** Pull the viewfinder table lock lever ① toward the rear panel, then pull the release knob ② and slide the viewfinder table in the direction of the arrow ③.

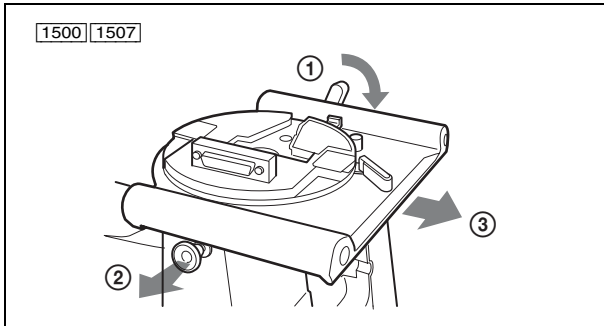

- 3** Push the rear panel lock release lever on the left panel down to open the rear panel.

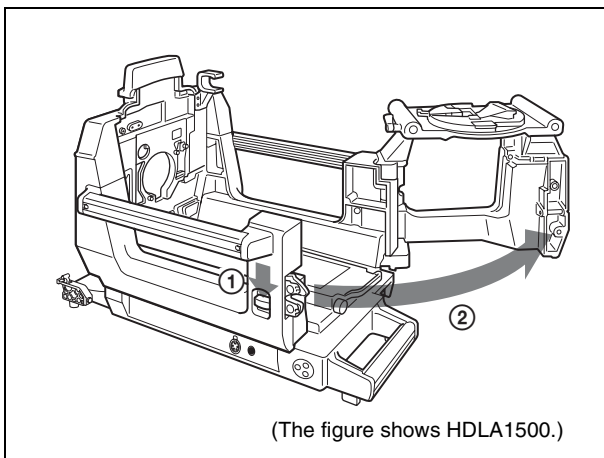

- 4** Remove the viewfinder from the camera (if attached).
5 Mount the camera.

For the HDLA1500/1505

- ① Remove the lens (lens cap) from the camera and push the lens mount lever fully downward.

- ② Check that the cover of the SHUTTER switch of the camera is closed.
 ③ Fix the viewfinder base of the camera in the position closest to the handle.

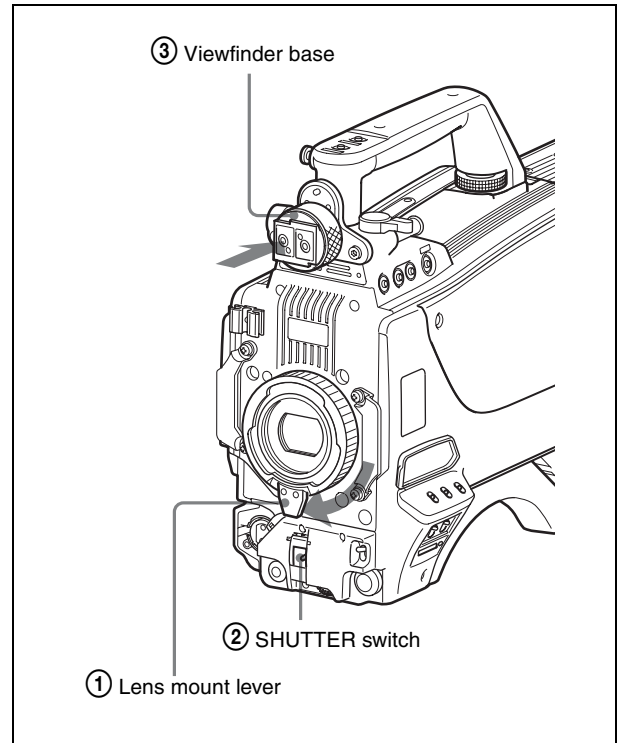

- ④ Place the camera inside and slide it forward until it locks in place.

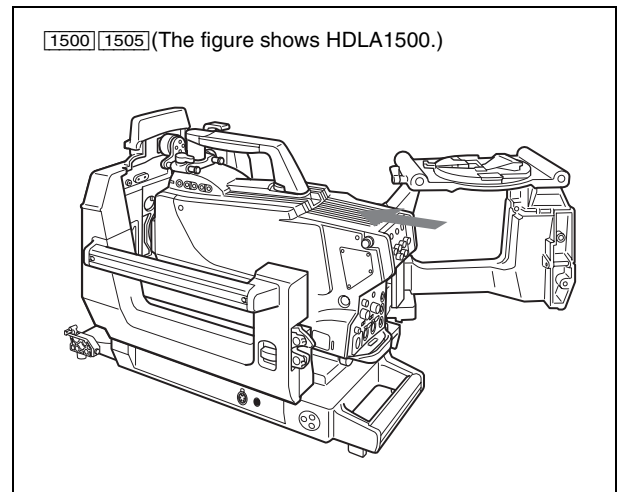

- ⑤ Press the camera lock lever on the front panel fully downward to secure the camera in place.

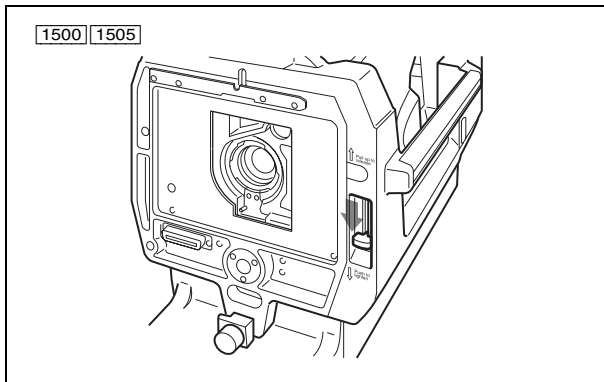

For the HDLA1507

Place the camera inside and slide it forward until it locks in place.

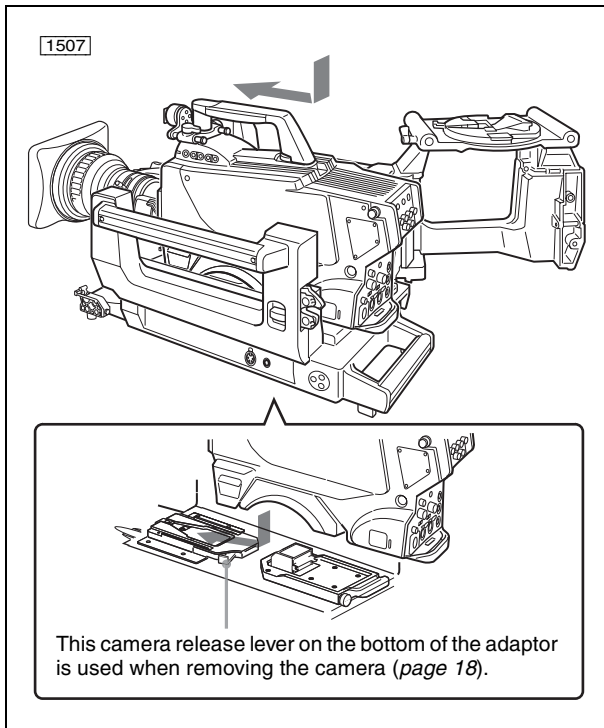

6 Close the rear panel.

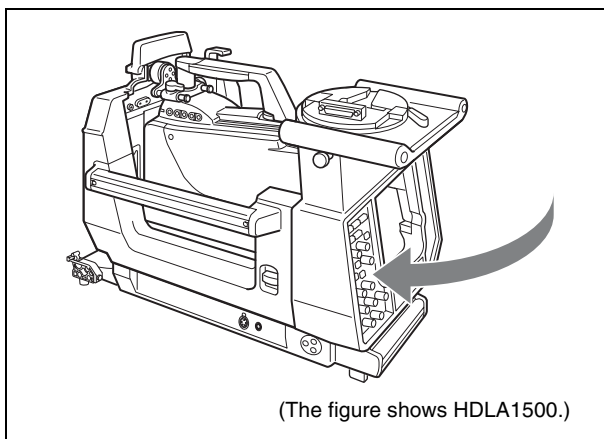

Caution

Check that the rear panel is locked firmly.

To remove the camera

While the figures of the adaptors in the following steps show the states where the studio lens and the large viewfinder have been already removed, the camera can also be removed with the lens and viewfinder attached to the adaptor.

For the HDLA1505, start from step 2.

- 1** Pull the viewfinder table lock lever ① toward the rear panel, then pull the release knob ② and slide the viewfinder table in the direction of the arrow ③.

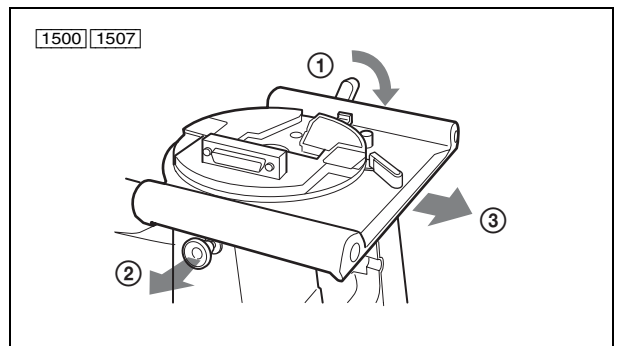

- 2** Push the rear panel lock release lever on the left panel down to open the rear panel.

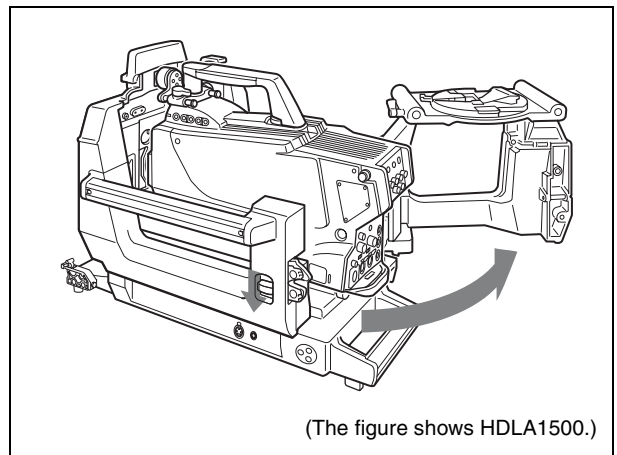

- 3** Remove the camera.

For the HDLA1500/1505

While holding the camera lock lever on the front panel upward, and pull the camera rearward until it stops then remove it.

1500 1505 (The figure shows HDLA1500.)

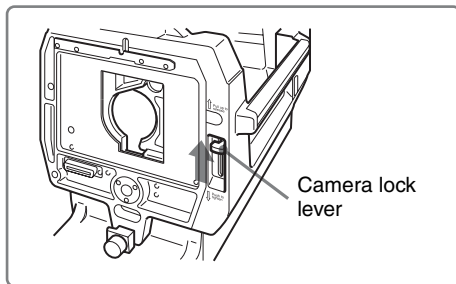

Camera lock lever

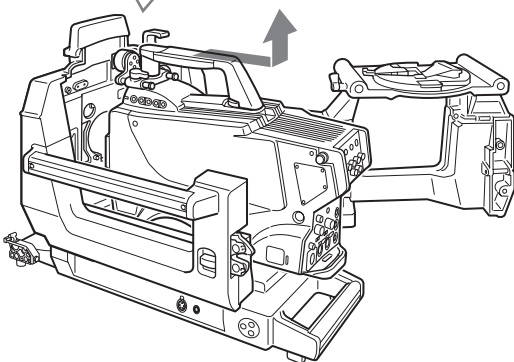

For the HDLA1507

While holding the camera lock lever on the front panel upward, and pull the camera rearward until it stops then remove it.

1507

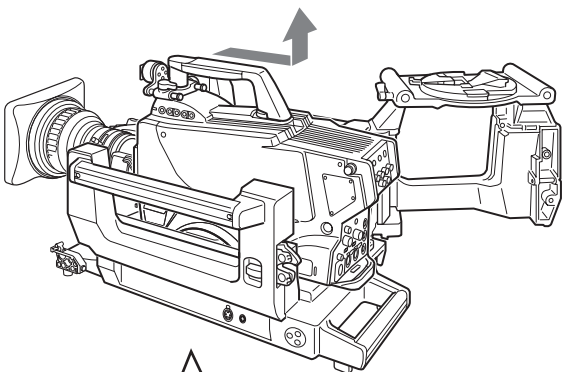

Camera release lever

4 Close the rear panel.

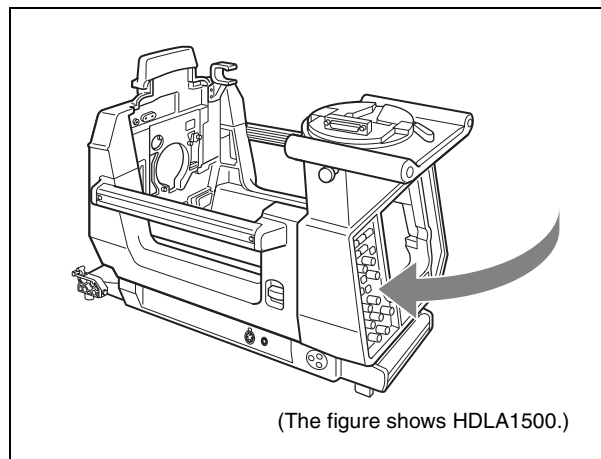

(The figure shows HDLA1500.)

Caution

Check that the rear panel is locked firmly.

Attaching a Large Viewfinder (HDLA1500/1507)

Attach a large viewfinder to the panning base mounting plate of the adaptor.

When using the HDVF-9900 viewfinder, attach the stopper supplied with the adaptor to the side panel of the adaptor (*see page 15*).

Note

The viewfinder is to be attached to the camera when you are using the HDLA1505. For the attaching procedure, refer to the instruction manual furnished with the viewfinder.

Viewfinder attachment mechanism

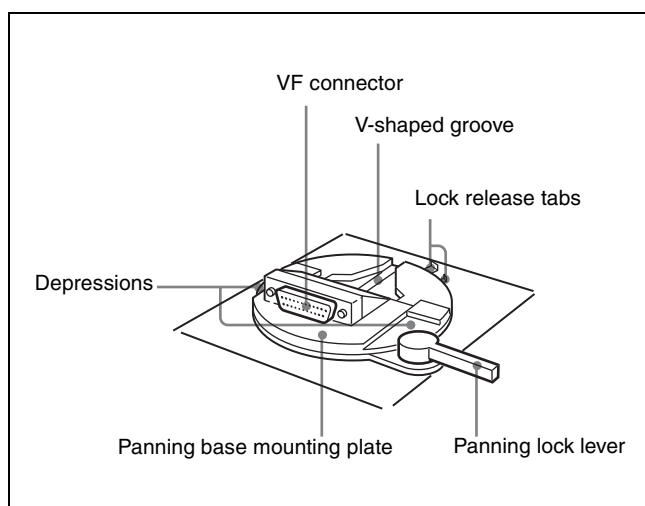

Example: Attaching a 7-type or 9-type viewfinder

For details on the attaching procedure, refer to the instruction manual furnished with the viewfinder.

Note

Before attaching the viewfinder to the adaptor, check to be sure that the VF connector on the panning base mounting plate faces in the direction 90 degrees clockwise from the rear panel of the adaptor as shown in the figure for step 1 below.

- 1 Place the viewfinder so that the mounting wedge on the rear of the panning base of the viewfinder enters the V-shaped groove on the panning base mounting plate of the adaptor. Make sure that the projections on the bottom of the viewfinder are in the appropriate positions.

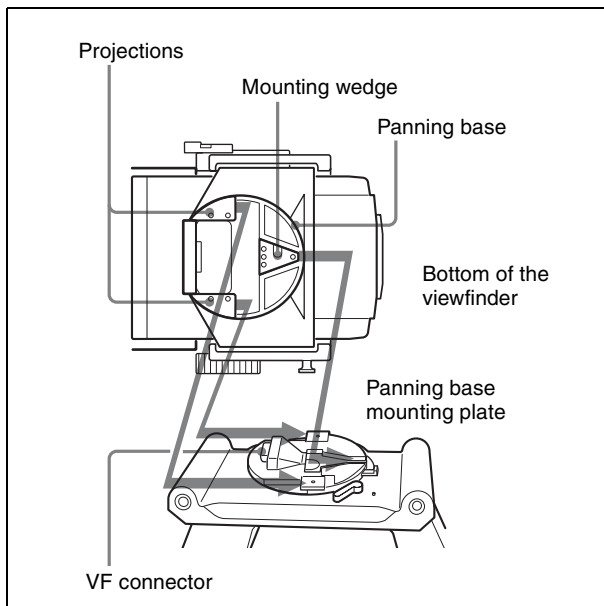

- 2 Push the viewfinder by the handle so that the panning base is held securely by the panning base mounting plate.

The connection with the viewfinder will be made by the VF connector of the adaptor. Pull the handle to check that the viewfinder is fixed to the adaptor.

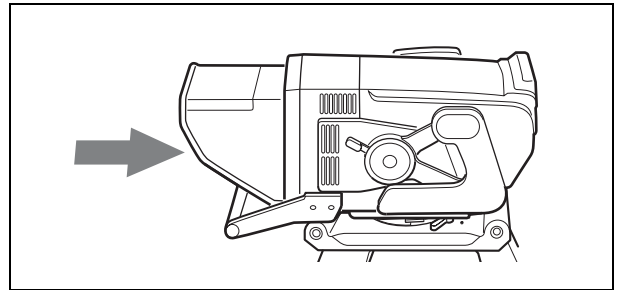

- 3 Turn the viewfinder counterclockwise. Then turn the panning lock lever counterclockwise to lock the viewfinder in place.

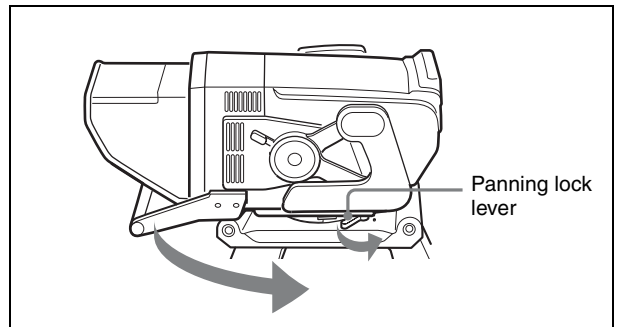

To adjust the viewfinder position

When using an HDC-series camera

You can use the viewfinder in any of three positions. To change the viewfinder position, proceed as follows:

- 1 Loosen the knob ① of the handle and push in on the tab ② to release the handle.

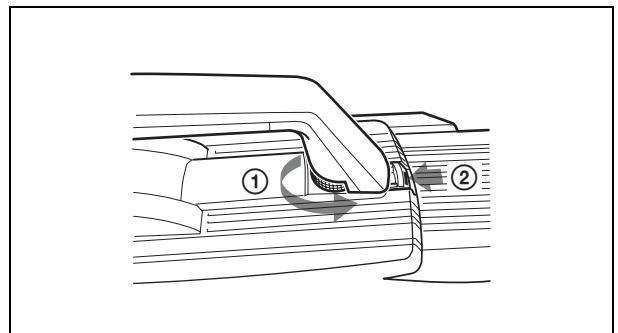

- 2 Rotate the handle toward the front.

In case of the HDLA1500, push the handle into the catch on the adaptor.

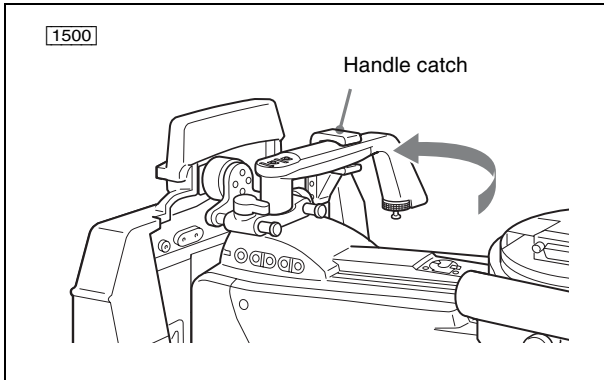

- 3** While pulling the release knob ① on the left side to release the viewfinder table, slide the table as ② to an appropriate position. Then push the lock lever ③ toward the front to lock the viewfinder table in place.

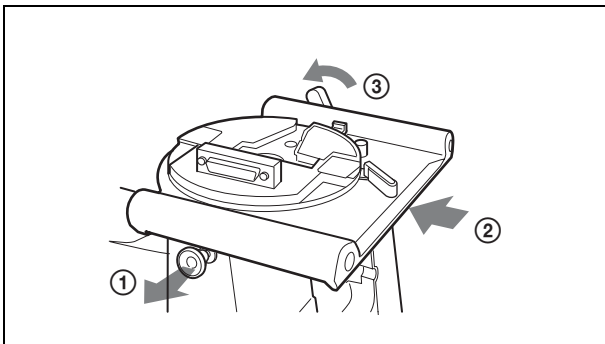

When returning the camera handle to its original position

Fully return the handle until it locks in place and firmly tighten the knob of the handle.

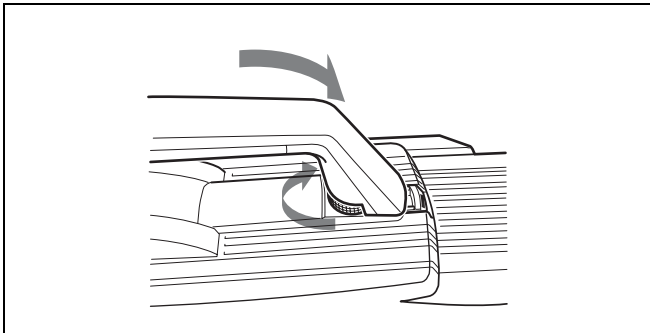

When using the HSC- 300

The viewfinder can be set either in the center or back position. You can pan the viewfinder in the range of ± 90 degrees only when it is set in the back position.

To remove the viewfinder

- 1** Release the panning lock lever and turn the viewfinder 90 degrees clockwise from the operation panel of the adaptor.

You cannot detach the viewfinder from the camera unless it is in this position.

- 2** While pushing in on the lock release tabs, grip the viewfinder handle and lift the viewfinder to remove it from the adaptor.

Attaching a Large Studio Lens (HDLA1500/1505)

Notes

Be sure to check the following two points before attaching the lens:

- The pan-lock and tilt-lock levers on the tripod are fixed.
- There is not a pin at part A on the lens shown in the figure for step 2 (if there is, remove it). If the pin cannot be removed, consult your Sony representative.

- 1** Loosen the lens lock holding knob and turn the lens lock counterclockwise.

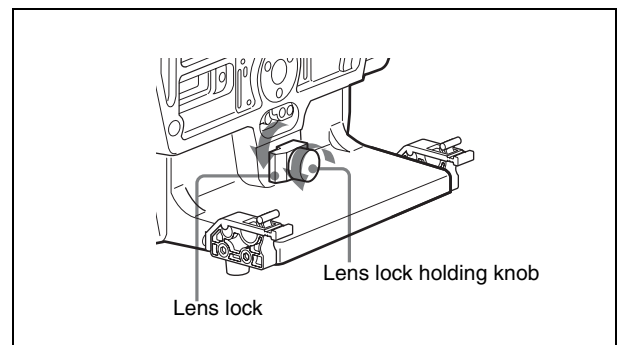

- 2** Insert the pin on the rear of the lens in the U-shaped notch on the front of the lens adaptor.

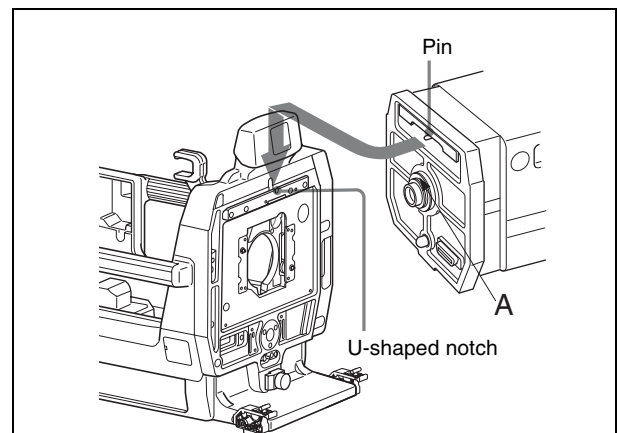

Note

If there is a pin at part A on the lens, remove it. Otherwise, the focal length adjustment may not be made. If the pin cannot be removed, consult your Sony representative.

- 3** Push the rear face of the lens onto the front face of the lens adaptor then turn the lens lock holding knob clockwise.

Make sure that the lens lock stands back and holds the tonguelike protrusion at the lens bottom.

If not, turn the lens lock holding knob counterclockwise to perform this step again.

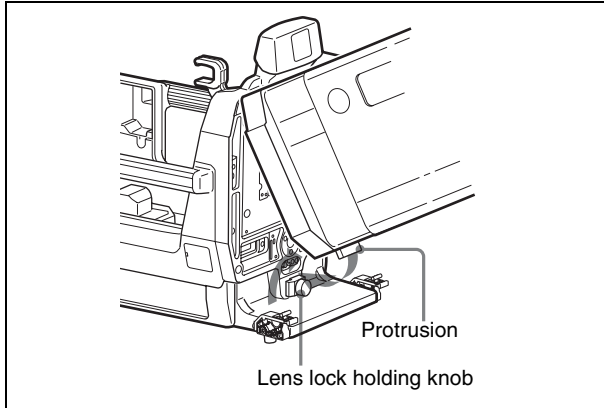

Mounting on the Tripod

Fitting the V-wedge shoe attached to the base of the adaptor, mount the camera assembly on the tripod.

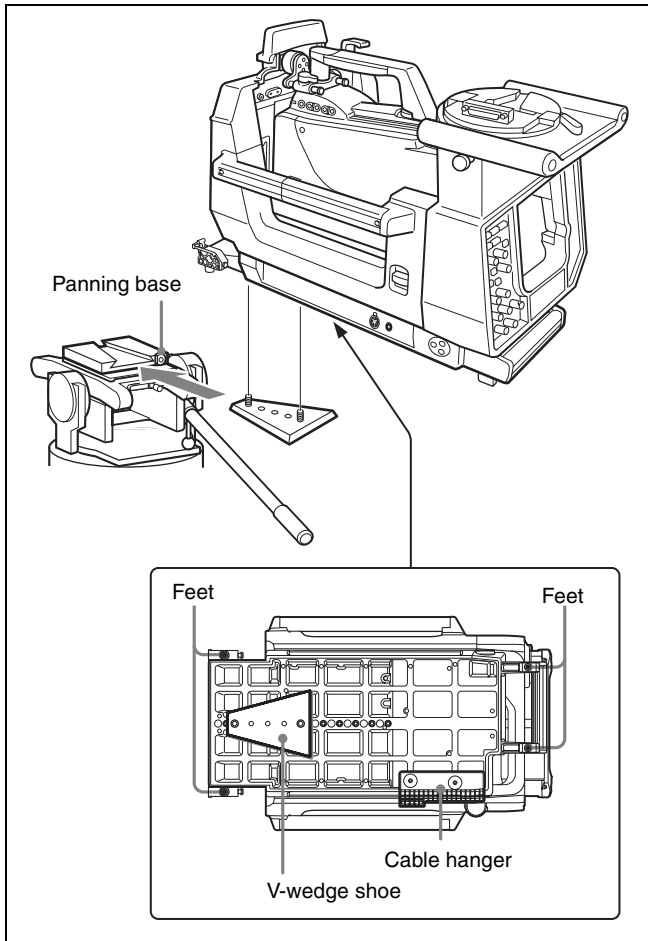

Note

Some tripods cannot be attached unless the feet and cable hanger are removed from the adaptor. Remove the feet and hanger to use such a tripod (*see page 14*).

Connecting the Camera Cables

You can connect/disconnect cables to/from the camera mounted in the adaptor without opening the rear panel of the adaptor.

Pass the cables through the opening below the rear panel.

When you connect cables with the rear panel of the adaptor open, make sure that the cables are not caught when you close the rear panel.

Attaching the Number Plates

Insert the projections on the both sides of a number plate (supplied) into the notches in the holder on the side panel. The number plate for the up tally can be attached in the same manner.

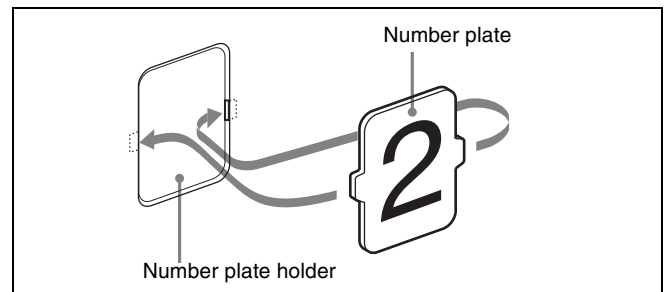

Specifications

General

Power requirements	240 V AC, 1.2 A (max.) 180 V DC, 0.65 A (max.) 12 V DC, 9 A (max.)
Operating temperature	-20°C to +45°C (-4°F to +113°F)
Storage temperature	-20°C to +60°C (-4°F to +140°F)
Mass	HDLA1500: Approx. 18.5 kg (40 lb 13 oz) HDLA1505: Approx. 17.1 kg (37 lb 11 oz) HDLA1507: Approx. 15.5 kg (34 lb 3 oz)

Input/output connectors

LENS	36-pin (1) (HDLA1500/1505 only)
VF	D-sub 25-pin (1) (HDLA1500/1507 only)
DC IN	XLR 4-pin (1), 10.5 to 17 V DC
DC OUT	Round 4-pin (1), 10.5 to 17 V DC, 1.5 A maximum (It may be limited depending on the load and input conditions.) XLR 4-pin (1), 10.5 to 17 V DC, 5A maximum (It may be limited depending on the load and input conditions.) The power supply from this unit is 7.7 A in total.

Supplied accessories

- Operation manual (1)
- Camera hangers (2) (HDLA1500/1505)
- Angle-adjusting plates (2)
- Cable clamps (2)
- Number plates for side panel (2 sets)
- Number plates for up-tally lamp (1 set) (HDLA1500/1505)
- Stopper (1) (HDLA1500/1507)
- Fixing screw for stopper (1) (HDLA1500/1507)

Optional accessories

- HD Electronic Viewfinder
HDVF-700A (7-type, monochrome)
HDVF-EL100 (11-type, color)
- BKP-7911 Script Holder

Dimensions

HDLA1500

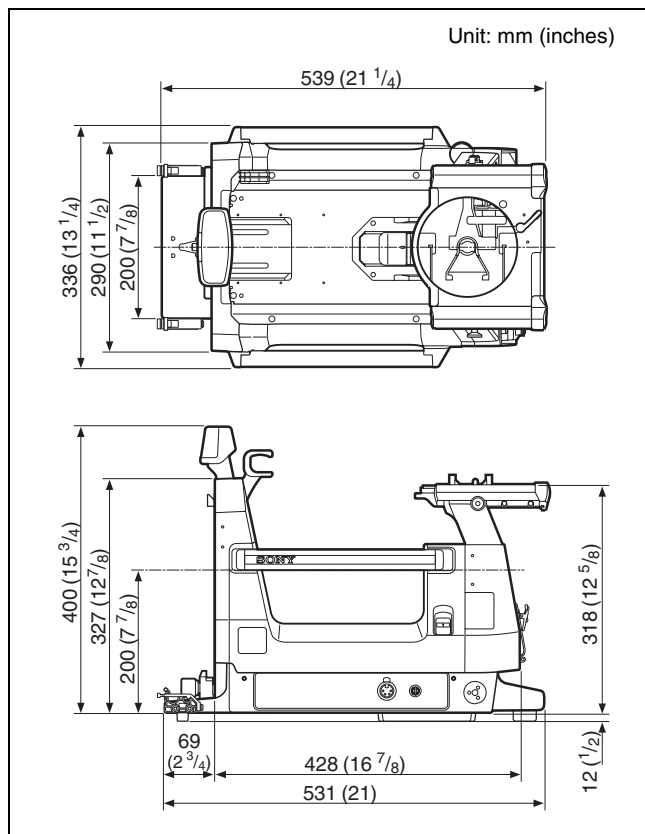

HDLA1505

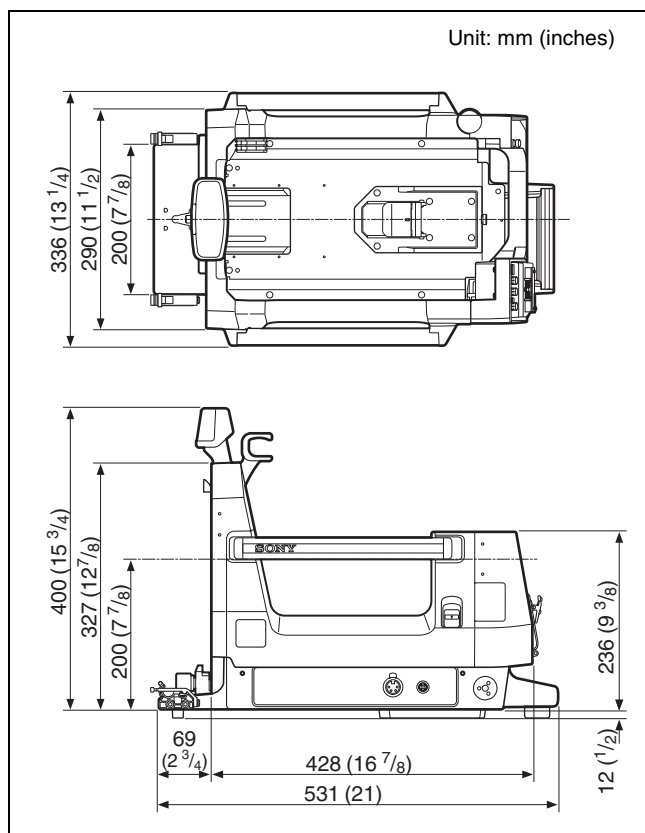

HDLA1507

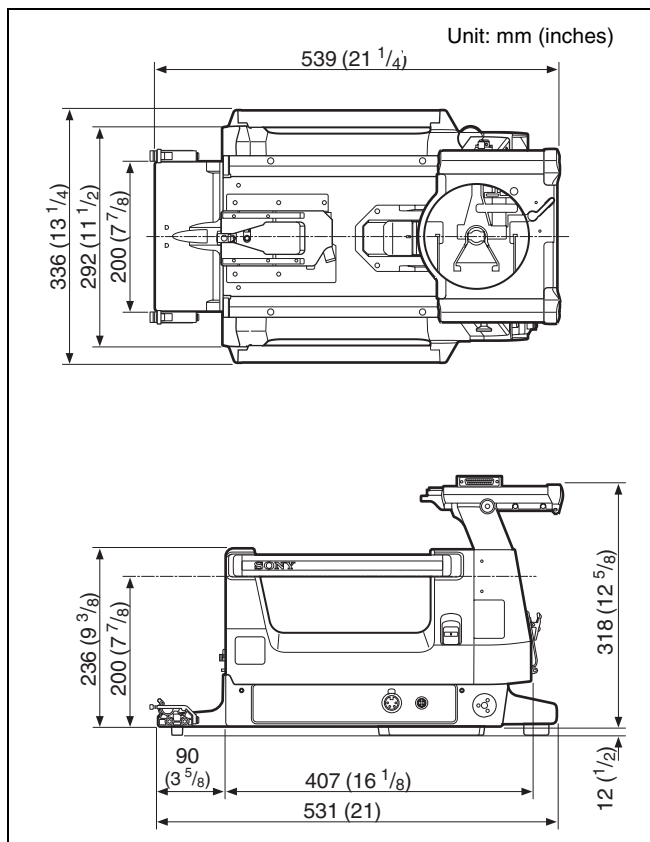

Design and specifications are subject to change without notice.

Note

Always verify that the unit is operating properly before use. SONY WILL NOT BE LIABLE FOR DAMAGES OF ANY KIND INCLUDING, BUT NOT LIMITED TO, COMPENSATION OR REIMBURSEMENT ON ACCOUNT OF THE LOSS OF PRESENT OR PROSPECTIVE PROFITS DUE TO FAILURE OF THIS UNIT, EITHER DURING THE WARRANTY PERIOD OR AFTER EXPIRATION OF THE WARRANTY, OR FOR ANY OTHER REASON WHATSOEVER.

The material contained in this manual consists of information that is the property of Sony Corporation and is intended solely for use by the purchasers of the equipment described in this manual.

Sony Corporation expressly prohibits the duplication of any portion of this manual or the use thereof for any purpose other than the operation or maintenance of the equipment described in this manual without the express written permission of Sony Corporation.

For Customer in China

根据中华人民共和国信息产业部第39号令《电子信息产品污染控制管理办法》及标准中要求的“有毒有害物质或元素名称及含量”等信息，本产品相关信息请参考以下链接：
<http://pro.sony.com.cn>

制造商：索尼公司
原产地：日本
总经销商：索尼（中国）有限公司
进口商地址：北京市朝阳区东三环北路霞光里18号佳程大厦A座25层

出版日期：2009年3月



4145591010

HDLA1500 (JN/CE)
HDLA1505 (JN/CE)
HDLA1507 (JN/CE)
4-145-591-01(1)

Sony Corporation

<http://www.sony.net/>

Printed on recycled paper.

Printed in Japan
2009.03 13
© 2005

Free Manuals Download Website

<http://myh66.com>

<http://usermanuals.us>

<http://www.somanuals.com>

<http://www.4manuals.cc>

<http://www.manual-lib.com>

<http://www.404manual.com>

<http://www.luxmanual.com>

<http://aubethermostatmanual.com>

Golf course search by state

<http://golfingnear.com>

Email search by domain

<http://emailbydomain.com>

Auto manuals search

<http://auto.somanuals.com>

TV manuals search

<http://tv.somanuals.com>