

Digital Photo Printer

DPP-FP35

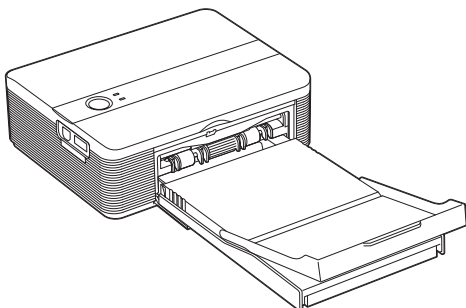

Before you begin

Preparations

Printing from a PictBridge camera (PictBridge mode)

Printing from a PC (PC mode)

Troubleshooting

Additional information

Operating Instructions

Before operating this printer, please read this manual thoroughly and retain it for future reference.

Owner's Record

The model and serial numbers are located on the bottom. Record the serial number in the space provided below. Refer to these numbers whenever you call upon your Sony dealer regarding this product.

Model No. DPP-FP35

Serial No. _____



WARNING

To reduce fire or shock hazard, do not expose the unit to rain or moisture.

For the customers in the U.S.A. CAUTION

You are cautioned that any changes or modifications not expressly approved in this manual could void your authority to operate this equipment.

If you have any questions about this product, you may call:

*Sony Customer Information Services Center
1-800-222-SONY (7669)*

The number below is for the FCC related matters only.

Regulatory Information

Declaration of Conformity

Trade Name: SONY

Model No.: DPP-FP35

Responsible Party:

Sony Electronics Inc.

Address: 16530 Via Esprillo,
San Diego, CA 92127 U.S.A.

Telephone No.: 858-942-2230

This device complies with part 15 of the FCC Rules. Operation is subject to the following two conditions:

(1) this device may not cause harmful interference, and (2) this device must accept any interference received, including interference that may cause undesired operation.

Note:

This equipment has been tested and found to comply with the limits for a Class B digital device, pursuant to Part 15 of the FCC Rules.

These limits are designed to provide reasonable protection against harmful interference in a residential installation. This equipment generates, uses, and can radiate radio frequency energy and, if not installed and used in accordance with the instructions, may cause harmful interference to radio communications. However, there is no guarantee that interference will not occur in a particular installation. If this equipment does cause harmful interference to radio or television reception, which can be determined by turning the equipment off and on, the user is encouraged to try to correct the interference by one or more of the following measures:

- Reorient or relocate the receiving antenna.
- Increase the separation between the equipment and receiver.
- Connect the equipment into an outlet on a circuit different from that to which the receiver is connected.
- Consult the dealer or an experienced radio/TV technician for help.

For the Customer in Europe

This product has been tested and found compliant with the limits set out in the EMC Directive for using connection cables shorter than 3 meters (9.8 feet).

Attention

The electromagnetic fields at the specific frequencies may influence the picture of this digital photo printer.

Notice

If static electricity or electromagnetism causes data transfer to discontinue midway (fail), restart the application or disconnect and connect the communication cable (USB, etc) again.

Disposal of Old Electrical & Electronic Equipment (Applicable in the European Union and other European countries with separate collection systems)





This symbol on the product or on its packaging indicates that this product shall not be treated as household waste. Instead it shall be handed over to the applicable collection point for the recycling of electrical and electronic equipment. By ensuring this product is disposed of correctly, you will help

prevent potential negative consequences for the environment and human health, which could otherwise be caused by inappropriate waste handling of this product. The recycling of materials will help to conserve natural resources. For more detailed information about recycling of this product, please contact your local Civic Office, your household waste disposal service or the shop where you purchased the product.

NOTICE FOR CUSTOMERS IN THE UNITED KINGDOM

A moulded plug complying with BS 1363 is fitted to this equipment for your safety and convenience.

Should the fuse in the plug supplied need to be replaced, a fuse of the same rating as the supplied one and approved by ASTA or BSI to BS 1362, (i.e. marked with  or  mark) must be used.

If the plug supplied with this equipment has a detachable fuse cover, be sure to attach the fuse cover after you change the fuse. Never use the plug without the fuse cover. If you should lose the fuse cover, please contact your nearest Sony service station.

Duplication, edition, or printing of a CD, TV programs, copyrighted materials such as pictures or publications, or any other materials except for your own recording or creation is limited to private or domestic use only. Unless you hold copyright or have permission of copyright holders for the materials to be duplicated, use of those materials beyond this limit may infringe the provisions of the copyright law and be subject to the copyright holder's claim for damages.

When using photo images with this printer, pay special attention not to infringe the provisions of the copyright law. Any unauthorized use or modification of others' portrait may also infringe their rights.

For some demonstrations, performances, or exhibits, photography may be forbidden.

Backup recommendations

To avoid potential risk of data loss caused by accidental operation or malfunction of the printer, we recommend that you save a backup copy of your data.

Information

IN NO EVENT SHALL SELLER BE LIABLE FOR ANY DIRECT, INCIDENTAL OR CONSEQUENTIAL DAMAGES OF ANY NATURE, OR LOSSES OR EXPENSES RESULTING FROM ANY DEFECTIVE PRODUCT OR THE USE OF ANY PRODUCT.

On trademarks and copyrights

- Cyber-shot is the trademark of Sony Corporation.
- Microsoft, Windows® and DirectX are registered trademarks of Microsoft Corporation in the United States and other countries.
- IBM and PC/AT are registered trademarks of International Business Machines Corporation.
- Intel and Pentium are the registered trademarks or trademarks of Intel Corporation.
- All other companies and product names mentioned herein may be the trademarks or registered trademarks of their respective companies. Furthermore, "TM" and "®" are not mentioned in each case in this manual.

- This software is based in part on the work of the independent JPEG Group.

- Libtiff

Copyright © 1988-1997 Sam Leffler

Copyright © 1991-1997 Silicon Graphics, Inc.

Permission to use, copy, modify, distribute, and sell this software and its documentation for any purpose is hereby granted without fee.

Notice for users

Program © 2006 Sony Corporation
Documentation ©2006 Sony Corporation

All rights reserved. This manual or the software described herein, in whole or in part, may not be reproduced, translated or reduced to any machine readable form without prior written approval from Sony Corporation.

IN NO EVENT SHALL SONY CORPORATION BE LIABLE FOR ANY INCIDENTAL, CONSEQUENTIAL OR SPECIAL DAMAGES, WHETHER BASED ON TORT, CONTACT, OR OTHERWISE, ARISING OUT OF OR IN CONNECTION WITH THIS MANUAL, THE SOFTWARE OR OTHER INFORMATION CONTAINED HEREIN OR THE USE THEREOF.

By breaking the seal of the envelope of the CD-ROM package, you accept all the terms and conditions of this agreement. If you do not accept these terms and conditions, please return this disk envelope unopened, along with the rest of the package, immediately to the dealer where you obtained it.

Sony Corporation reserves the right to make any modification to this manual or the information contained herein at any time without notice. The software described herein may also be governed by the terms of a separate user license agreement.

Any design data such as sample pictures provided in this software cannot be modified or duplicated except for the purpose of personal use. Any unauthorized duplication of this software is prohibited under copyright law.

Please note that unauthorized duplication or modification of others' portraits or copyrighted work could infringe the rights reserved by right holders.

Table of contents

Before you begin

Overview	6
What you can do with this printer	6
Identifying the parts	8

Preparations

1 Checking the contents of the package	10
2 Preparing the print pack	11
Size of print paper	11
Optional print packs	11
3 Loading the print cartridge	12
4 Inserting the print paper	13
5 Connecting the AC power source ...	16

Printing from a PictBridge camera (PictBridge mode)

Printing images from the digital camera	17
---	----

Printing from a PC (PC mode)

Installing the software	19
System requirements	19
Installing the printer driver	20
Installing the Picture Motion Browser	23

Printing photos from the Picture

Motion Browser	25
Printing from other application software ..	32

Troubleshooting

If trouble occurs	34
If paper jams	42
Cleaning the inside of the printer	42

Additional information

Precautions	44
Specifications	45
Printing range	47
Glossary	48
Index	49

Overview

What you can do with this printer

The Digital Photo Printer DPP-FP35 provides the following two operation modes, depending on the device you use for printing.

Printing from a PictBridge camera (PictBridge mode) → Page 17

Connect a PictBridge-compliant digital camera to the printer to print images using the camera.

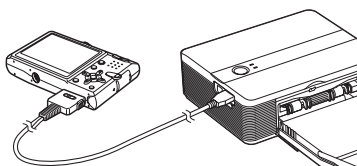

Printing from a PC (PC mode) → Page 19

Connect a PC to the printer to print images using the PC.

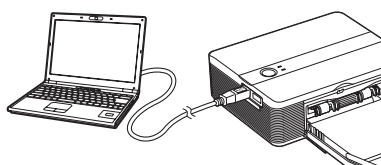

Depending on the operation mode you choose, follow the operation flow below:

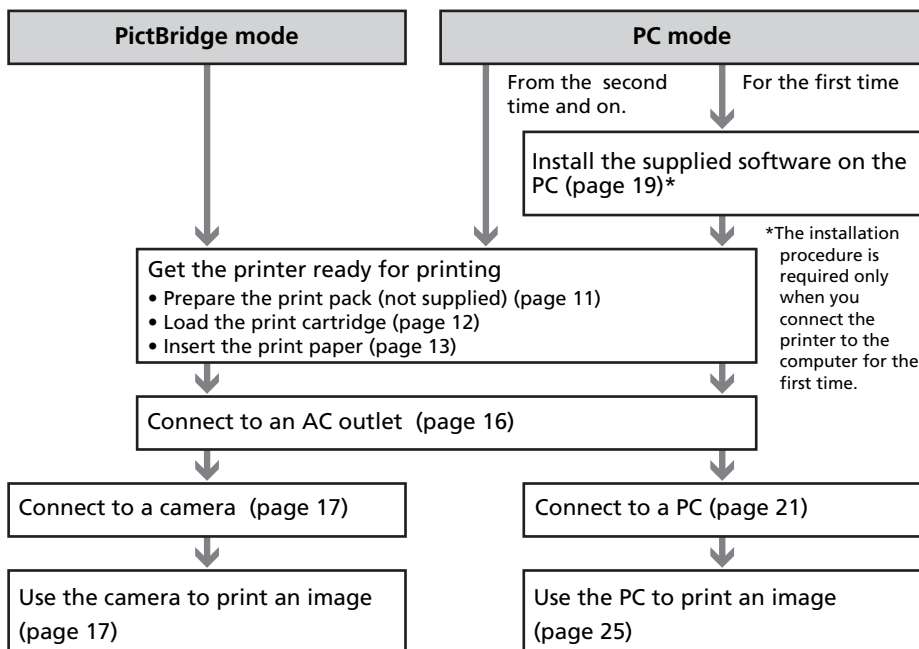

PictBridge-compliant* (page 17)



The printer supports the PictBridge standard, so that you can print an image easily from a PictBridge-compliant digital camera.

Windows PC support with a convenient USB connection (page 19)

By connecting the printer to your PC via a USB connector and installing the supplied printer driver, you can print images from your PC.

Super Coat 2

The Super Coat 2 feature enables high durability and moisture or fingerprint resistance, keeping your prints in good condition for an extended period of time.

Auto Fine Print 3

The Auto Fine Print 3 analyses the picture information of an image, including the Exif data, and corrects the resulting picture to make an image look more natural and beautiful.

Exif 2.21 (Exif Print) support (page 29)**



When you use the supplied Picture Motion Browser software to print an image from your PC, you can choose Exif Print picture correction in addition to the conventional OS picture correction. In Exif Print correction, the supplied printer driver uses the Exif data of an image and the printer's color processing to adjust and reproduce an image with supreme picture quality.

Red-eye reduction and other adjustments (PC mode only, page 29)

You can adjust an image to reduce the red-eye phenomenon that may occur when the subject was shot with flash. Adjustments of brightness, hue, and other elements of picture quality are also possible.

Paper tray allowing bulk printing of 20 sheets (page 14)

With the supplied paper tray, you can print up to 20 sheets of print paper at one time.

* PictBridge is a standard that allows you to connect a digital camera directly to a printer without a PC, enabling direct printing on the spot.





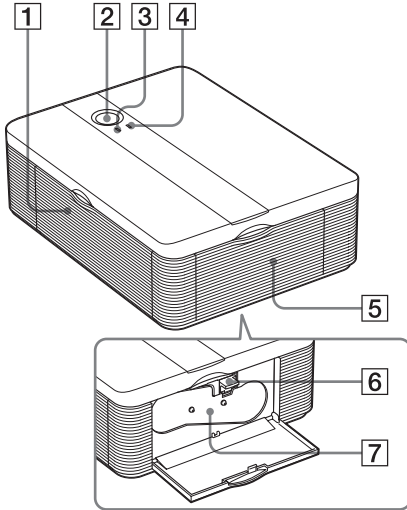

** Exif (Exchangeable image file format for digital cameras) Print is a global standard for digital photo printing. A digital camera supporting Exif Print stores data relevant to the shooting conditions as each shot is taken. The printer utilises the Exif Print data stored in each image file to ensure the printed result matches the original shot as closely as possible.

Identifying the parts

For details, see the pages indicated in the parentheses.



Printer

- 1 Paper tray compartment door (page 15)**
- 2  (on/standby) switch (page 17)**
 - To turn on the printer, press  to turn on the  indicator in yellow green.
 - To turn off the printer, keep pressing  for more than one second until the  indicator turns in red.
-  (on/standby) indicator (page 17)**
 - Lights in red: The printer is in the standby mode.
 - Lights in yellow green: The printer is powered on.
 - Flashes in yellow green: Printing is in process.
- 3 PICTBRIDGE indicator (page 18)**
 - Lights: The printer is being connected to a PictBridge-compliant digital camera.
 - Flashes: A device that does not support the PictBridge feature is connected. Or, the image to be printed is damaged.
- 4 ERROR indicator (page 12)**
 - Lights: The paper tray is not inserted.
No print paper is in the paper tray.
Paper remains in the printer.
 - Flashes slowly: The print cartridge ends. No print cartridge is inserted.
 - Flashes rapidly: Paper is jammed.
- 5 Print cartridge compartment door (pages 12, 13)**
- 6 Print cartridge eject lever (page 12)**
- 7 Print cartridge (pages 12, 13)**

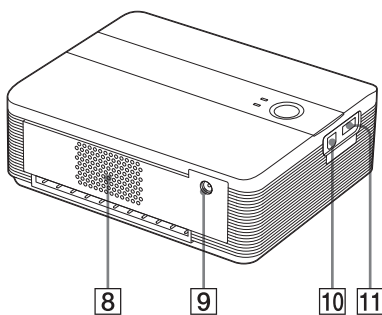

8 Ventilation holes

9 DC IN 24V jack (page 16)

Insert the AC power adaptor supplied here, and then connect the AC power adaptor and the wall outlet with the supplied AC power cord.

10 USB connector (page 21)

Connects to the USB connector of your PC.

11 PictBridge connector (page 17)

Connect the PictBridge-compliant digital camera.

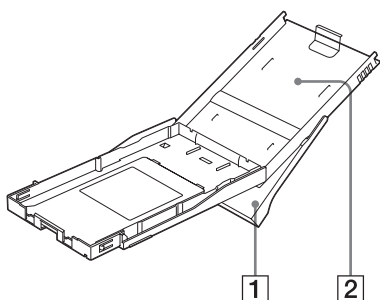

Paper tray

1 Paper eject tray (pages 13, 14)

2 Paper tray lid (pages 13, 14)

1 Checking the contents of the package

Make sure that the following accessories are supplied with your printer.

Paper tray (1)

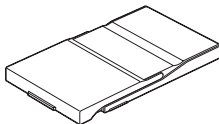

AC adaptor (AC-S2425) (1)

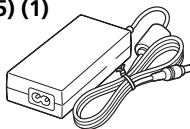

AC power cord * (1)

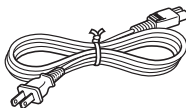

* The AC power cord illustrated is for 120V only. The plug shape and specifications of the AC power cord differ depending on the region you purchased the printer.

Cleaning cartridge (1)

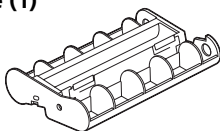

CD-ROM (1)

- Sony DPP-FP35 Printer Driver Software for Windows® XP Professional/Windows® XP Home Edition/Windows® 2000 Professional/Windows® Millennium Edition
- Picture Motion Browser Ver.1.1

- Sample color print pack (Post card size, 10 sheets)
- Operating Instructions (this booklet, 1)
- Quick Start Guide (1)
- Warranty (1)*
- Sony End User Software License Agreement (1)

* In some regions, the warranty is not supplied.

2 Preparing the print pack

To print an image, you need a print pack designed for the printer. The sample color print pack contains a set of 10 sheets of post card size print paper and a print cartridge for 10 prints.



Size of print paper

The size of the post card size print paper is as follows:

- Post card (4 x 6 inch/10 x 15 cm) size (101.6 x 152.4 mm) (the maximum borderless printing size)

Optional print packs

You can use the following optional print packs for the printer:

Post card size print pack

SVM-F40P

- 40 sheets of 4 x 6 inch print paper (20-sheet-pack x 2)
- Print cartridge for 40 prints

SVM-F80P

- 80 sheets of 4 x 6 inch print paper (20-sheet-pack x 4)
- 2 print cartridges each for 40 prints

SVM-F120P

- 120 sheets of 4 x 6 inch print paper (20-sheet-pack x 6)
- 3 print cartridges each for 40 prints

Notes on using print packs

- Always use the print pack designed for this printer only. If you use different types of print pack, printing may not be possible or malfunction may occur.
- The side without the imprinting is the printing surface. Inferior print quality may result if the printing surface is contaminated with dust or fingerprints. Be careful to avoid touching the printing surface.
- **Do not bend the paper or tear it off at the perforations before printing.**
- **Do not print on used sheets of print paper or attempt to rewind the ribbon inside the print cartridge. Doing so could result in damages to the printer.**
- Please do not disassemble the print cartridge.
- Do not pull out the ribbon from the print cartridge.

Notes on storing print packs (for quality prints)

- When you are going to store a partially-used pack of the print cartridge and print paper for an extended period of time, store it in its original bag or in a similar container.
- Avoid placing the print pack in locations that are subject to high temperature, high humidity, excessive dust, or direct sunlight.
- Use print pack within two years from the date of production.

Note on storing printouts

Do not affix cellophane tape or plastic erasers to printouts. Also avoid leaving printouts under plastic desk mats.

Note

Not all models are available in all countries.

3 Loading the print cartridge

- 1 Pull and open the cartridge compartment door.

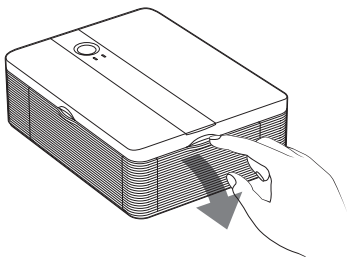

- 2 Insert the print cartridge in the arrow direction until it clicks into place.

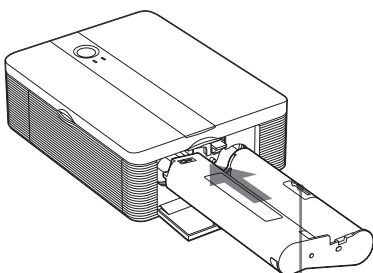

Arrow

- 3 Close the cartridge compartment door.

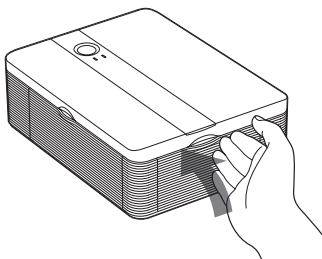

Removing the print cartridge

When the print cartridge runs out, the ERROR indicator will flash slowly.

Open the cartridge compartment door, push up the eject lever, and remove the used print cartridge.

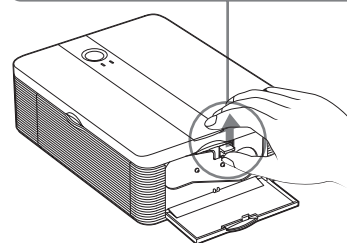
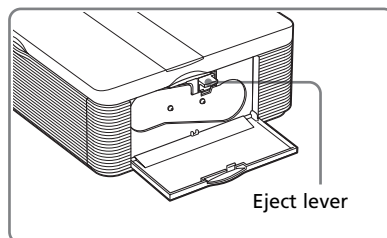

Notes

- Use the print cartridge contained in the same box with the print paper.
- Do not touch the ink ribbon or place the print cartridge in a dusty location. Fingerprints or dust on the ink ribbon may result in imperfect printing.

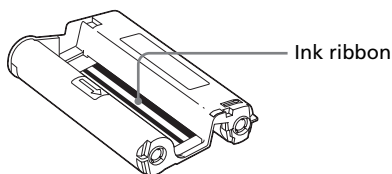

- Never put your hand into the cartridge compartment. The thermal head reaches high temperatures, especially after repeated printing.

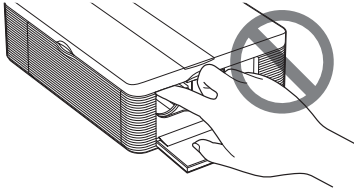

- Do not rewind the ink ribbon and use the rewound print cartridge for printing. Otherwise, proper printing result will not be obtained, or even a malfunction may occur.
- If the print cartridge does not click into place, remove it and then re-insert it. If the ink ribbon is too slack to be loaded, wind the ink ribbon in the direction of the arrow to remove the slack.

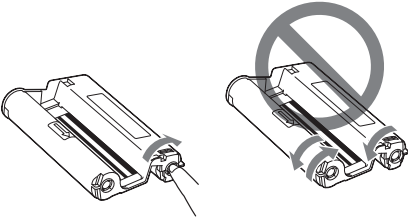

- Do not remove the print cartridge while printing.

Notes on storing the print cartridge

- Avoid placing the print cartridge in a location subject to high temperatures, high humidity, excessive dust or direct sunlight.
- When you are going to store a partially-used cartridge, store it in its original bag.

4 Inserting the print paper

- 1 Open the paper eject tray.

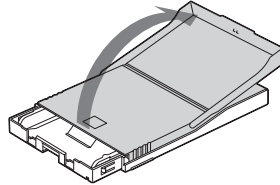

- 2 Slide the paper tray lid in the opposite direction to the paper feeding direction (1) and then lift it up (2).

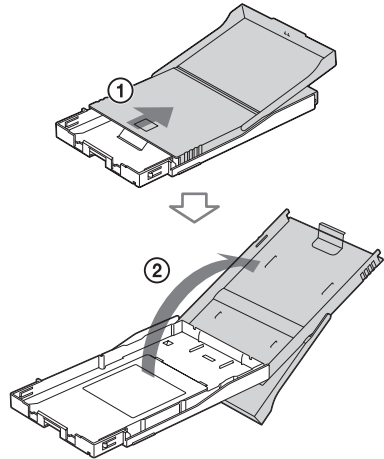

Continued

- 3** Set the print paper into the tray. You can set up to 20 sheets of print paper. Riffle the print paper thoroughly. Insert the print paper into the tray, with the protective sheet at the top. If there is no protective sheet: Riffle the print paper thoroughly. Then insert the print paper with its printing surface (the side with no imprint) facing up.

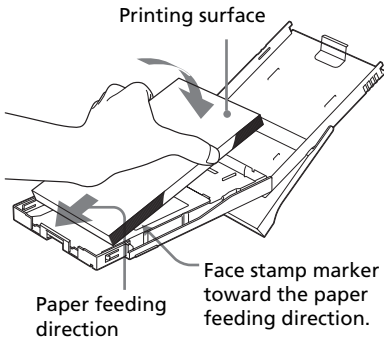

To set the print paper, face the stamp marker toward the paper feeding direction.

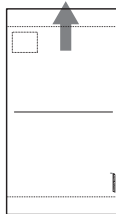

Note

Do not touch the printing surface. Fingerprints on the printing surface may result in imperfect printing.

- 4** Remove the protective sheet.

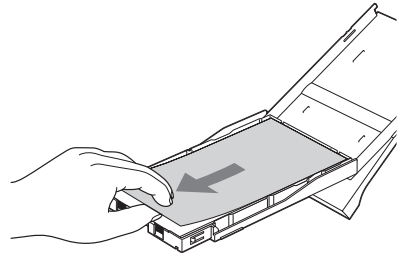

- 5** Close the paper tray lid (①) and slide it to the paper feeding direction (②). Keep the paper eject tray open.

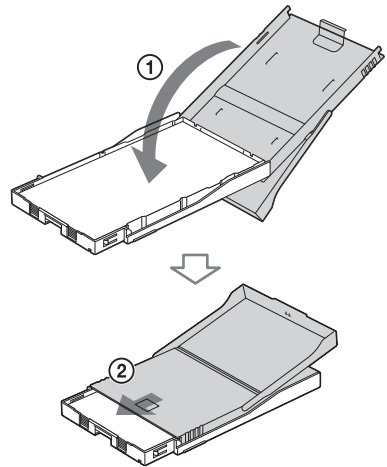

- 6** Pull and open the printer's paper tray compartment door.

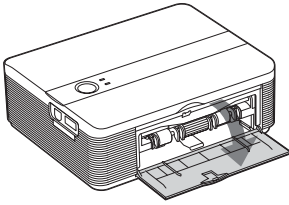

- 7** Insert the paper tray into the printer.
Insert the paper tray straight in until it reaches the end.

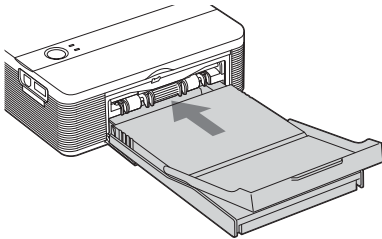

Note

Make sure that the paper tray is not inserted at any angle. If it is, the printer will not print properly.

Notes

- Do not remove the paper tray during printing.
- To avoid paper jam or malfunctions of the printer, make sure the following before printing:
 - Do not write or type on the print paper. Use the oil ink pen to write on the paper after printing. You cannot type on the print paper using an ink-jet printer, etc.
 - Do not attach sticker or stamps on the print paper.
 - Do not fold or bend the print paper.
 - Total number of print paper does not exceed 20 sheets.
 - Do not print on the used print paper. Printing an image twice on the same paper will not make the printed image thicker.
 - Use the print paper for this printer only.
 - Do not use the print paper ejected without printed.

Notes on storing the print paper

- Avoid storing the paper with the printed faces touching each other or in contact with rubber or plastic products including vinyl chloride or plasticizer for an extended period of time; color changes or deterioration of the printed image may occur.
- Avoid placing the print paper in a location subject to high temperatures, high humidity, excessive dust or direct sunlight.
- When you are going to store partially-used print paper, store it in its original bag.

5 Connecting the AC power source

- 1 Insert one plug of the supplied AC power cord to the supplied AC adaptor.
- 2 Insert the other plug of the AC power cord to the wall outlet close by (wall socket).
- 3 Insert the plug of the AC adaptor to the DC IN 24V jack of the printer.
The ⏻ (on/standby) indicator lights in red.

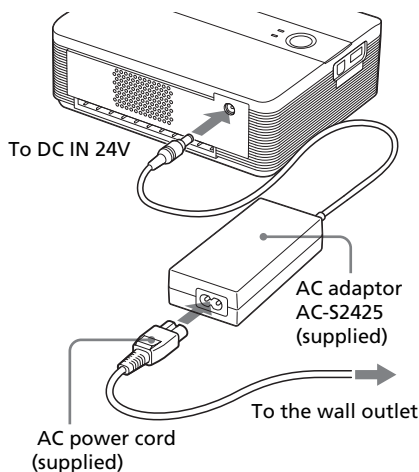

Precautions

- The printer is not disconnected from the AC power source (mains) as long as it is connected to the wall outlet, even if the printer itself has been turned off.
- Connect the AC adaptor to an easily accessible wall outlet close by. If some trouble occurs while using the adaptor, immediately shut off the power by disconnecting the plug from the wall outlet.
- When you have finished using the AC adaptor, disconnect it from the DC IN 24V jack of the printer.
- The print paper emerges from the rear a few times during printing. Do not block the rear with the AC adaptor or AC power cord.
- Be sure to use the AC adaptor supplied with the printer. Do not use other AC adaptor, as this may cause malfunction.
- In case the cord of the AC adaptor is damaged, never use it any longer, as this may cause danger.
- Do not short the DC plug of the AC adaptor with a metallic object, as this may cause malfunction.
- Do not use the AC adaptor in a narrow space, such as the one between the printer and the wall.

Printing images from the digital camera

You can connect a PictBridge-compliant digital camera and print an image directly from your digital camera.

Before you begin



You need preparations 1 through 4 (pages 10 to 15), and the following:

- 1 Set your digital camera ready for printing with a PictBridge-compliant printer.
The settings and operations that are necessary before connection differ depending on the digital camera. For details, see the operating instructions of the digital camera you use. (In case of Sony Cyber-shot digital camera, for example, select "PictBridge" or "Auto" mode for the "USB Connect".)

Note

When you use a DSC-T1, you need to update software version.

- 2 Connect the printer to the AC power source (page 16).
 - 1 Insert one plug of the supplied AC power cord to the supplied AC power adaptor.
 - 2 Insert the other plug of the AC power cord to the wall outlet.
 - 3 Insert the plug of the AC power adaptor to the DC IN 24V jack of the printer.
 The  (on/standby) indicator lights in red.

- 3 Press  (on/standby) switch to turn on the printer.
The  (on/standby) indicator of the printer lights in yellow green.

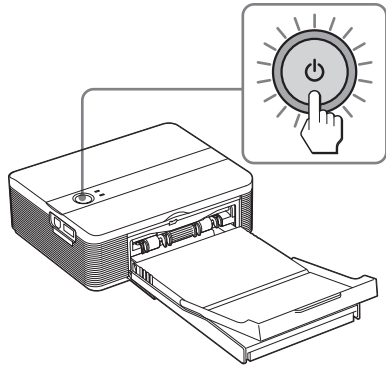

- 4 Connect a PictBridge-compliant digital camera to the PictBridge connector of the printer.
Use the USB cable supplied with the digital camera.

To PictBridge connector (USB A-TYPE)

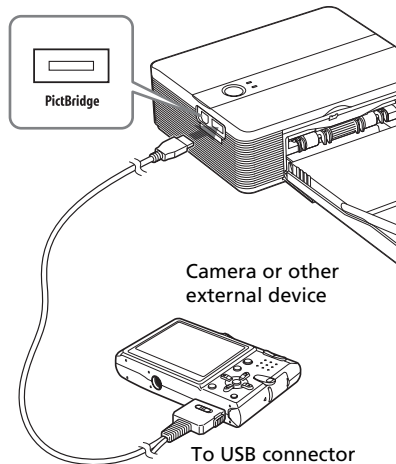

Continued

Notes

- You cannot connect a PictBridge-compliant digital camera and a PC simultaneously to the printer. When printing from a digital camera, remove the PC from the printer.
- The connector is designed for the PictBridge only. Never connect a device other than a PictBridge-compliant digital camera.
- The type of USB cable you should use may differ depending on the digital camera. Use a USB cable with an A-TYPE connector for the printer and an appropriate type for your digital camera.
- If you use a commercially available USB cable, please use the one shorter than 3m in length.

When you connect a PictBridge-compliant digital camera to the printer

The printer automatically enters the PictBridge mode. The PICTBRIDGE indicator turns to green.

PICTBRIDGE indicator

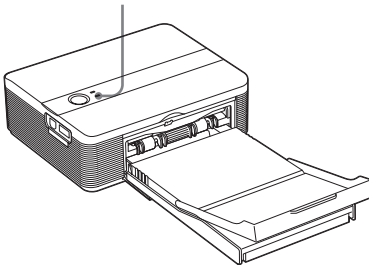

5 Operate the digital camera to print an image.

The printer supports the following prints:

- Single-image print.
- All images print
- Index print
- DPOF print
- Border/Borderless print
- Date print

Notes on printing

- If you replace a print cartridge while the printer is connected to a PictBridge-compliant digital camera, an image may not be printed properly. If this occurs, disconnect and then connect the digital camera.
- Never move or turn off the printer while it is printing; the print cartridge or paper may become stuck. In case you turn off the power, keep the paper tray inserted and then turn on the printer. If paper being printed remains in the printer, remove the paper that emerged automatically and resume printing from the step 1.
- The print paper emerges a few times during printing. Do not touch nor pull the emerged paper. Wait for the print paper to be fully ejected after printing ends.
- As the print paper emerges from the rear a few times during printing, make sure to spare enough space behind the printer during printing.
- If print paper runs out during continuous printing or if you print with no print paper in the paper tray, the printer's ERROR indicator lights. Feed the print paper without turning off the power and resume printing.

On the PICTBRIDGE indicator

The PICTBRIDGE indicator shows the connection status between the printer and the digital camera as follows:

- When the indication lights: The connection between the printer and the PictBridge-compliant digital camera is established.
- When the indication blinks: The device that does not support the PictBridge feature is connected. Or the image to be printed is damaged.

You can print the images from a PC by installing the supplied software on your PC and connecting it to the printer.

This section explains how to install the supplied software on your PC and how to use the supplied Picture Motion Browser software to print an image.

Please also refer to the operating instructions supplied with your PC.

Installation of the software is necessary only when you connect the printer to your PC for the first time.

On the supplied CD-ROM

The supplied CD-ROM contains the following software:

- Printer driver for DPP-FP35: The software describes the printer's requirements and enables printing from the computer.
- Picture Motion Browser: Sony's original software application that allows you to handle photographs and moving images—capturing, managing, processing, and printing.

Installing the software

System requirements

To use the supplied printer driver and Picture Motion Browser, your PC must meet the following system requirements:

OS: Microsoft Windows® XP Professional/Windows® XP Home Edition/Windows® 2000 Professional/Windows® Millennium Edition, pre-installed (IBM PC/AT compatible)

(Windows 95, Windows 98 Gold Edition, Windows 98 Second Edition, Windows NT, other versions (ex. Server) of Windows 2000 are not supported.)

CPU: Pentium III 500MHz or faster (Pentium III 800MHz or faster is recommended.)

RAM: 128 MB or more (256 MB or more is recommended.)

Hard disk space: 200 MB or more (Depending on the Windows version you use, more space will be required. To handle image data, you will need additional hard disk space.)

Display:

Screen area: 800 x 600 pixels or more
Colors: High Color (16-bit) or more

Required software: DirectX 9.0 or higher (Required for the Picture Motion Browser.)

Notes

- If a hub is used to connect the printer and your PC, or if two or more USB devices including other printers are connected to your PC, a trouble may occur. If this occurs, simplify the connections between your PC and the printer.
- You cannot operate the printer from another USB device being used simultaneously.

Continued

- Do not remove the USB cable from or connect it to the printer during data communication or printing. The printer may not work properly.
- Do not allow the PC connected to the printer to switch to standby mode or hibernation mode during printing. If you do so, the printer may not print properly.
- We cannot guarantee operations with all personal computers, even though they may meet or exceed the system requirements.
- Picture Motion Browser supports the DirectX technology and the DirectX installation may be required.

Installing the printer driver

- 1 Make sure that the printer is **disconnected** from the computer.

Note

If you connect the printer to your PC in this stage, either of the following dialog boxes are displayed:

- When using Windows Me: Add New Hardware Wizard
- When using Windows 2000/XP: Found New Hardware Wizard

If this occurs, disconnect the printer from the PC and then click "Cancel" in the dialog box.

- 2 Turn on your computer and start Windows.

- When installing or uninstalling the software in Windows® 2000 Professional, log on to Windows as "Administrator" or "Power user".
- When installing or uninstalling the software with Windows® XP Professional/Windows® XP Home Edition, log on using a "Computer administrator" user account.

Notes

- Be sure to close all running programs before installing the software.
- The dialog boxes in this section are those in Windows XP Professional, unless otherwise specified. The installation procedures and the dialog boxes shown differ depending on the operating system.

- 3 Insert the supplied CD-ROM into the CD-ROM drive of your computer.
The setup starts automatically and the installation window is displayed.

Note

In case the installation window is not automatically displayed, double-click the "Setup.exe" of the CD-ROM.

- 4 Click "Installing Printer Driver".

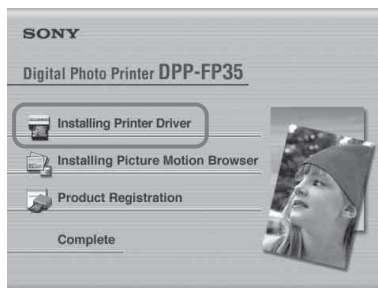

The "Sony DPP-FP35 - InstallShield Wizard" dialog box appears.

- 5 Click "Next".
The license agreement dialog box is displayed.

6 Check “I accept the terms of the license agreement” and click “Next”.

If you check “I do not accept the terms of the license agreement”, you cannot proceed to the next step.

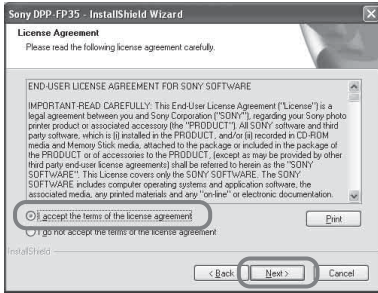

The “Ready to install the program” dialog box is displayed.

7 Click “Install”.

The “Printer connection” dialog box is displayed.

8 Connect the printer to the AC power source (page 16).

9 Press \odot (on/standby) switch to turn on the printer (page 17).

The \odot (on/standby) indicator of the printer lights in yellow green.

10 Click “Next”.



11 Connect the USB connectors of the printer and your computer.

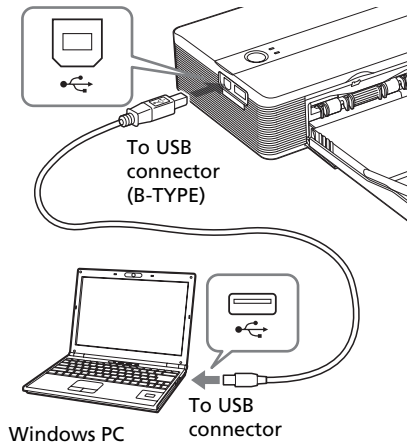

The printer automatically enters the PC mode and the printer setup will start automatically.

When the printer setup is complete, the “InstallShield Wizard Complete” dialog box is displayed.

Note

In case you use commercially available USB cable, use a B-type USB cable shorter than 3m in length.

12 Click “Finish”.

The installation of the printer driver is complete. When you are prompted to restart your computer, restart the computer.

13 • To finish installation, click “Complete” and remove the CD-ROM from your computer and keep it for future use.

• To continue to install the Picture Motion Browser software, click “Installing the Picture Motion Browser” and follow the procedures on page 23.

Notes

- If the printer driver CD-ROM is prompted during the installation, specify the following directory:
 - When using the Windows Me:
D:\DRIVER\winme
 - When using the Windows 2000/XP:
D:\DRIVER\win2000.xp“D” stands for the CD-ROM drive of your PC and may differ depending on the system.
- The supplied CD-ROM will be required when you uninstall or re-install the printer driver. Keep it in good order for possible future use.
- If the installation fails, remove the printer from your computer, restart your computer, and then do the installation procedures from the step 3.
- After installation, the “Sony DPP-FP35” is not set as the default printer. Set the printer you use for each application.
- Before you use the printer, read the Readme file (the Readme folder of the CD-ROM→English folder→Readme.txt).

Checking the installation

Open the “Printers and Faxes” (in case of Windows® XP Professional/Windows® XP Home Edition) or “Printers” from the “Control Panel”. When the “Sony DPP-FP35” is displayed in the “Printers and Faxes” or “Printers” window, the printer driver has been successfully installed.

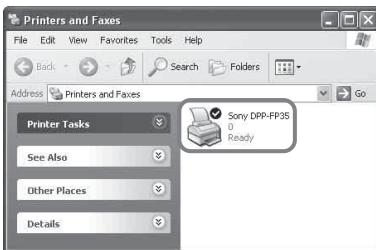

Uninstalling the printer driver

When the printer driver becomes unnecessary, remove it from your PC hard disk as follows:

- 1** Disconnect the USB cable from your printer and the computer.
- 2** Insert the supplied CD-ROM into the CD-ROM drive of your computer.
The setup starts automatically and the installation window is displayed.
- 3** Click “Installing Printer Driver”.
The “Sony DPP-FP35 - InstallShield Wizard” dialog box appears.
- 4** Click “Next”.
The license agreement dialog box is displayed.
- 5** Check “I accept the terms of the license agreement” and click “Next”.
The dialog box used for confirming uninstallation is displayed.
- 6** Click “Yes”.

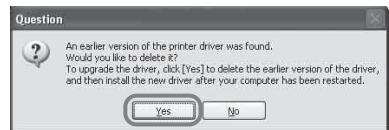

The dialog box used for restarting the computer is displayed.

7 Check "Yes, I want to restart my computer now" and click "OK".

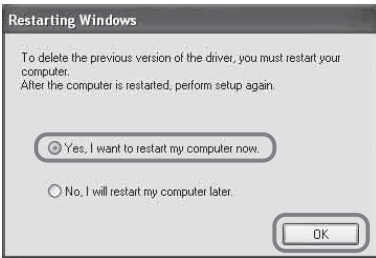

After the computer is restarted, the relevant files will be deleted and uninstallation is complete.

To check uninstallation

Select "Printers and Faxes" (in case of Windows® XP Professional/Windows® XP Home Edition) or "Printers" from the "Control Panel" to check if the "Sony DPP-FP35" is displayed. If not, the printer driver is successfully removed.

Installing the Picture Motion Browser

1 Turn on your computer and start Windows.

- When installing or uninstalling the software in Windows® 2000 Professional, log on Windows as the user name of "Administrator" or "Power user".
- When installing or uninstalling the software in Windows® XP Professional/Windows® XP Home Edition, log on as a user name with the "Computer administrator" user account.

Notes

- Be sure to close all running programs before installing the software.
- The dialog boxes in this section are those in Windows XP Professional, unless otherwise specified. The installation procedures and the dialog boxes shown differ depending on the operation system.

2 Insert the supplied CD-ROM into the CD-ROM drive of your computer.

The setup starts automatically and the installation window is displayed.

Note

In case the installation window is not automatically displayed, double-click the "Setup.exe" of the CD-ROM.

3 Click "Installing Picture Motion Browser."

The "Picture Motion Browser Setup" starts and the "Choose Setup Language" dialog box is displayed.

4 Select the language to be used during installation and click "Next."

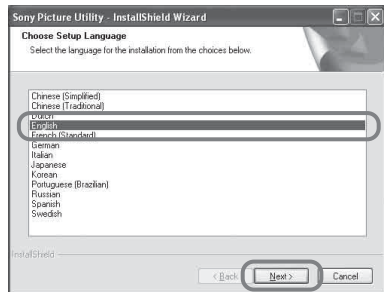

The "Sony Picture Utility Setup" dialog box is displayed.

5 Click "Next."

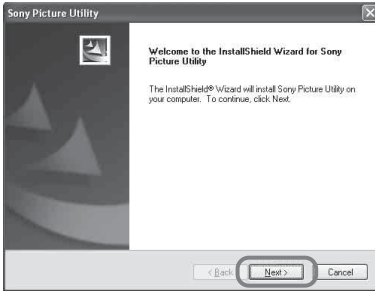

The license agreement dialog box is displayed.

6 Check "I accept the terms of the license agreement" and click "Next."

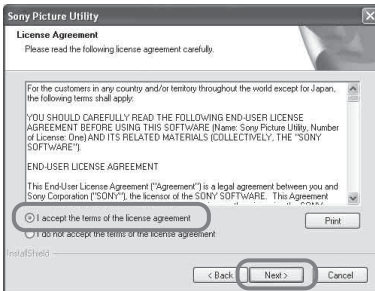

The dialog box used to specify the destination folder is displayed.

7 Check the destination and then click "Next."

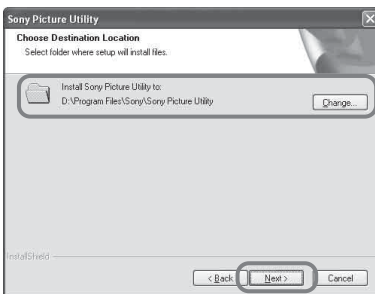

The "Ready to install the program" dialog box is displayed.

8 Click "Install."

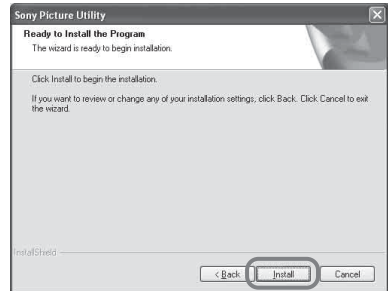

The "Setup Status" dialog box is displayed.

When the printer setup is complete, the "InstallShield Wizard Complete" dialog box is displayed.

9 Click "Finish."

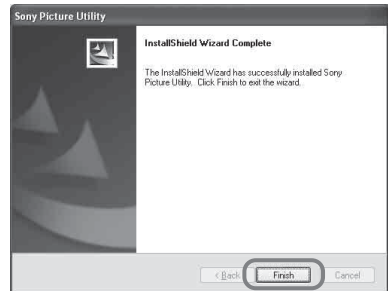

The installation of the Picture Motion Browser is complete. When you are prompted to restart your computer, restart it.

10 Remove the CD-ROM from your computer and keep it for future use.

Notes

- If the installation fails, perform the installation procedures from step 2 again.
- The supplied CD-ROM will be required when you uninstall or re-install the Picture Motion Browser. Keep it in a safe place for possible future use.

When the software is installed

The  is displayed on the Windows desktop, as well as a shortcut to the web site for printer customer registration. If you finish registration, you can find support information at:
<http://www.sony.net/registration/di/>

Uninstalling the Picture Motion Browser

When this software is no longer needed, remove it from your computer as follows:

- 1 Click "Start" - "Setting" - "Control Panel" (or "Start" - "Control Panel" with Windows XP).
- 2 Double-click "Add/Remove Programs."
The Control Panel is displayed.
- 3 Select "Sony Picture Utility" and click "Change/Remove" ("Remove" with Windows XP).
The software is uninstalled.

Printing photos from the Picture Motion Browser

You can use the Picture Motion Browser to print an image from your PC using post card size print paper.

- 1 Start the Picture Motion Browser window using either of the following methods:

- Double-click  (Picture Motion Browser) on the Windows desktop.
- Click "Start" - "All Programs" (or "Programs" with Windows 2000) - "Sony Picture Utility" - "Picture Motion Browser."

When the Picture Motion Browser is started for the first time, the registration window used to register a browsing folder is displayed. If images have already been saved in the "My Pictures" folder, click "Register Now."

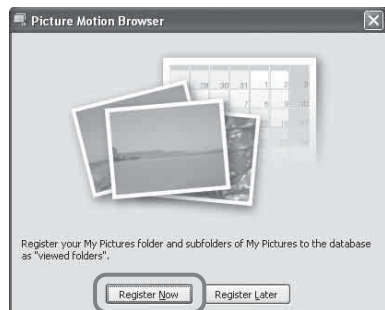

If you have saved images in a folder other than the "My Pictures" folder, click "Register Later." Refer to "To register a browsing folder" (page 31).

Continued

How to access the “My Pictures” folder

- In Windows Me/2000:
Click “My Documents” - “My Pictures” on the desktop.
- In Windows XP:
Click “Start” - “My Pictures” from the taskbar.

The main window of the Picture Motion Browser is displayed.

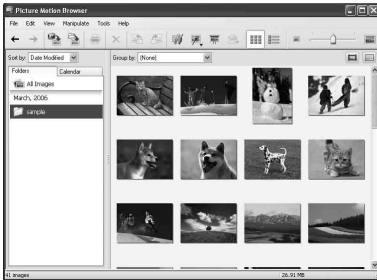

To switch the display of the main window

There are 2 different versions of photo view used in the main window as follows:

To switch the view, click the tab “Folders” or “Calendar.”

- “Folders” view
The images will be classified in each registered folder and are displayed as thumbnails.
- “Calendar” view
The images will be classified according to the shot date and are displayed as thumbnails on each date of the calendar. In “Calendar” view, you can switch the display according to the year, month, or hour.

- 2 Click the folder containing the photos you want to print.
As an example, the “sample” folder is selected in the following explanation.

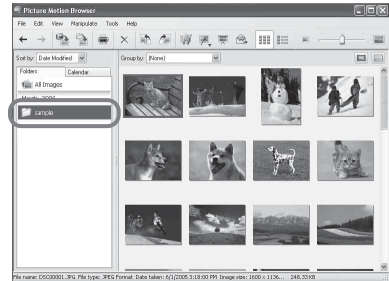

- 3 Select the photos that you want to print and click  (print).

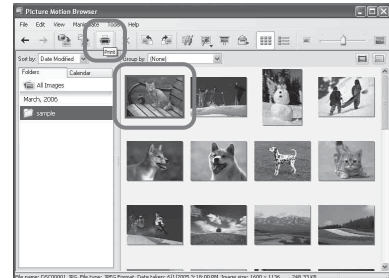

The Print dialog box is displayed.

- 4 In the “Print” drop-down list box, select “Sony DPP-FP35” and then click “Print.”

The preparations for printing starts.

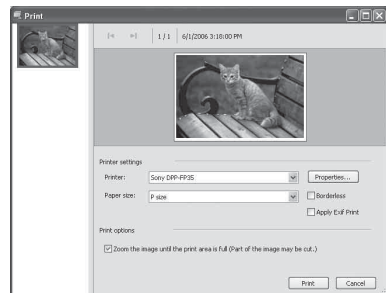

Items	Functions
Printer	Select "Sony DPP-FP35".

Paper size

From the drop-down list box, select the paper size you actually use for printing:

- P size
- L size

Note

In some regions, L size print paper is not sold.

Print options

- When checked, an image will be printed over the entire printing area of the paper. An edge of the photo may not be printed.
- When unchecked, an image will be printed without cutting off an edge.

Tip

To print an image without margins around it (Borderless Print), you must check this option.

Borderless

- When checked, an image will be printed without margins around it.
- When unchecked, an image will be printed with margins around it.

Tip

When you make a Borderless Print, you must check the "Zoom the image until the print area is full" item for Print options.

Items	Functions
Apply Exif Print	<ul style="list-style-type: none"> • When checked, an image shot with a Exif Print (Exif 2.21)-compliant digital camera will be adjusted and printed with its optimum picture quality.

Note

The image displayed on the monitor will not be adjusted.

- When unchecked, an image will be printed without adjustments.

Note

Even if you uncheck the item, "Color reproduction/ Picture quality" is still set to "Auto Fine Print 3". To change the "Color reproduction/Picture quality" settings, follow the Properties steps.

Properties

Specifies orientation, picture quality and other details.

To make detailed settings, click "Properties," so that the properties dialog box for the selected printer is displayed.

Continued

5 In the “Paper/Output” tab, specify the paper size.

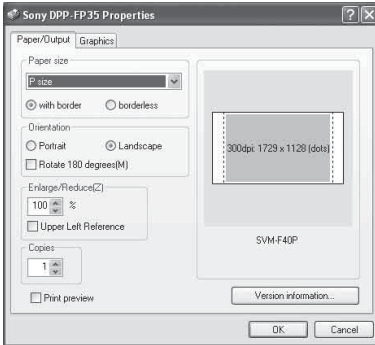

Items	Functions
-------	-----------

Paper size

From the drop-down list box, select the paper size you actually use for printing:

- P size
- L size

Then check either of the following to specify the margins around the image:

- with border: an image is printed with borders around it.
- borderless: an image is printed without borders around it.

Tip

The settings in the properties dialog box will be reflected in the Print dialog box.

Orientation

Select the orientation of an image when printed:

- Portrait
 - Landscape
 - Rotates 180 degrees
-

Items	Functions
-------	-----------

Copies	Specify the number of copies to be printed.
--------	---

Enlarge/Reduce

Specify the percentage to enlarge or reduce the size of an image when printed.

You can set the reference point when an image is enlarged or reduced by checking “Upper left reference”.

- When unchecked, an image is enlarged or reduced with the center as the reference point. Usually, use this option.
 - When checked, an image is enlarged or reduced with the upper left corner as the reference point.
-

Print preview

Check this option to display a preview of an image before printed.

6 In the “Graphics” tab, set the color reproduction and picture quality.

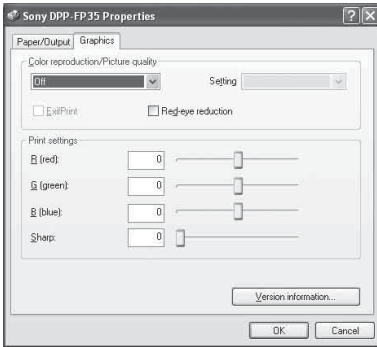

Items	Functions
-------	-----------

Color reproduction/Picture quality

Select the setting from the drop-down list box:

- **Off:** An image will be printed without adjustment.
- **Auto Fine Print 3:** From the “Settings” drop-down list box, select either of the following correction method:
 - **Photographical:** An image will be adjusted automatically and printed with natural and beautiful pictures. (Recommended option)
 - **Vivid:** An image will be adjusted automatically and printed with more vivid pictures. (In this setting, a stronger sharpness correction is given, making pictures more vivid.)

Items	Functions
-------	-----------

- **ICM (system):** From the “Settings” drop-down list box, select either of the following correction method:
 - **Graphics:** when graphics or vivid colors are used.
 - **Match:** when you want to match colors.
 - **Pictures:** when a photograph or pictures are printed.

ExifPrint

Check it to adjust and print an image shot with a Exif Print (Exif 2.21)-compliant digital camera. The printer driver uses the color conversion and Exif shooting data to adjust the image.

This option is effective only with Picture Motion Browser.

Tip

The settings in the properties dialog box will be reflected in the Print dialog box.

Red-eye reduction

Check it to automatically reduce the red-eye phenomenon of the subject shot by using a flash light.

Notes

- When you check this option, make sure to select “Preview” to display the preview image before printing and check that the red-eye reduction has been correctly processed to the image.

Items Functions

- Red-eye phenomenon will be detected automatically, and it may not be corrected.
If red-eye phenomenon is not corrected, use the Picture Motion Browser correction function.
- Red-eye reduction is enabled only when you have installed the printer driver from "Setup.exe" in the supplied CD-ROM. For the details see the Readme.txt.

Print settings

Adjusts the color elements and sharpness.

R (red): Adjusts the red and blue elements. The higher you set the level, the more reddish the picture becomes as if it receives red light. The lower you set the level, the darker the picture becomes as if light blue is added.

G (green): Adjusts the green and purple elements. The higher you set the level, the more greenish the picture becomes as if it receives green light. The lower you set the level, the darker the picture becomes as if red purple is added.

B (blue): Adjusts the blue and yellow elements. The higher you set the level, the more bluish the picture becomes as if it receives blue light. The lower you set the level, the darker the picture becomes as if yellow is added.

Sharp (sharpness): The higher you set the sharpness level, the more distinct the outlines become.

7 Click "OK."

The print dialog box is displayed.

Tip

When "Print preview" is checked in step 5, the preview window is displayed. Check the results of any adjustments and then click "Print."

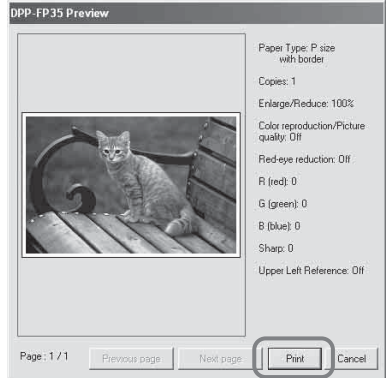

Printing resumes. Make sure to read "Notes on printing" on page 18, as well.

For the details of the properties of the Picture Motion Browser, see the Picture Motion Browser online Help.

Note

You cannot print a motion-picture file or RAW data files.

Tips

- To select serial still images in the image area of the main window, click the first image in the series and then click the last image while pressing the Shift key.
- To select multiple still images not in a sequence, click the images individually while pressing the Ctrl key.
- You can print from an image preview.
- The Picture Motion Browser is compatible with the ICM.

To register a browsing folder

The Picture Motion Browser does not allow you to view images saved on the PC hard disk directly. You must to register the browsing folder as follows:

- 1 Click "File" - "Register Viewed Folder," or click  (Register Folders to View).

The browsing folder registration window is displayed.

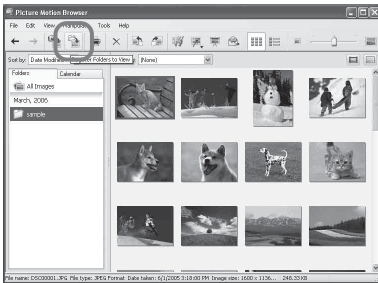

- 2 Select the folder you want to register and then click "Register."

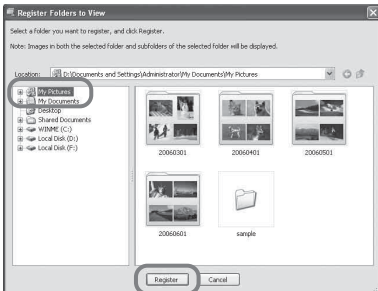

Note

You cannot register the whole drive.

- 3 Click "Yes."

Registration of the image information in the data base starts.

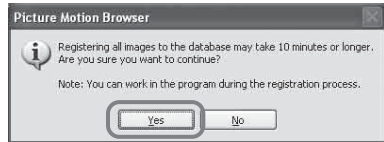

- 4 Click "Close."



Notes

- The folder you select as the destination of the imported images will be registered automatically.
- You cannot cancel registration of the folder you register here.

To change the browsing folder

Click "Tools" - "Settings" - "Viewed folders."

Tips

- If a sub folder is contained in the source folder, the images in the sub folder will also be registered.
- When the software is first started, the message prompting you to register "My Pictures" will be displayed.
- Depending on the number of images, it may take some tens of minutes to register images.

Continued

To stop printing

- 1 Double-click on the printer icon on the taskbar, and open the "Print" dialog box.
- 2 Click the document name that you want to cancel printing of and then click "Cancel" from the "Document" menu.

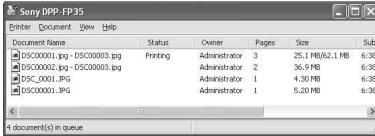

The dialog box used for confirming the deletion is displayed.

- 3 Click "Yes."
The printing job is canceled.

Note

Do not cancel the printing job during the printing process, which may cause a paper jam.

Printing from other application software

You can use a commercially-available application software to print an image from the DPP-FP35. Select "DPP-FP35" in the print dialog box and select the print paper size in the page setup dialog box. For details in print settings, see steps 5 and 6 on pages 28 and 29.

On "borderless" setting in the "Paper size" section

When using an application other than the Picture Motion Browser, an image might be printed with borders even if you select borderless print in the "Paper size" section of the "Paper/Output" tab in the "Sony DPP-FP35 Properties" dialog box.

When you select the borderless print option, the printing range information for borderless print will be supplied to the application. Some applications, however, may arrange and print the image with borders within the specified range.

If this occurs, do either of the following to print an image without borders:

- When you can set print range with an application, set an image to be printed fully in the print range. For example, select "Full page photo print" or a similar option.
- Set a larger value in the "Enlarge/Reduce" text box in the "Paper/Output" tab of the "Sony DPP-FP35 Properties" dialog box.

If borders remain on the right and bottom sides of a printed image even after you set a larger value, check "Upper left reference".

In either case, make sure to display and check the preview image before printing.

Orientation setting

Depending on the application software you use, orientation may not change even if you change portrait or landscape setting.

With border/borderless setting of the printer driver

When the application software you use has border/borderless setting, we suggest you select borderless as the printer driver setting.

Print quantity setting in the Properties dialog box

Depending on the application software you use, the print quantity setting of the application you use may have priority over the setting specified in the printer driver dialog box.

Exif Print Settings in the "Graphics" tab

The Exif Print setting in the "Color reproduction/Picture quality" section supports the Picture Motion Browser only. If you use other application to print an image with this option checked, the image may be printed with incorrect colors. If this occurs, remove the check.

If trouble occurs

If you run into any problems using the printer, use the following guidance to solve the problem. If the problem persists, consult your Sony dealer.

Power

Symptom	Check	Cause/Solutions
The ⏻ (on/standby) switch cannot be turned on.	<ul style="list-style-type: none"> • Is the AC power cord properly connected? 	<ul style="list-style-type: none"> ➔ Connect the AC power cord to an AC outlet securely. (➡ page 16)

Connecting with a digital camera

Symptom	Check	Cause/Solutions
The PICTBRIDGE indicator of the printer does not light.	<ul style="list-style-type: none"> • Is the digital camera connected correctly? 	<ul style="list-style-type: none"> ➔ Connect the cable correctly.
	<ul style="list-style-type: none"> • Is the printer turned on? 	<ul style="list-style-type: none"> ➔ Press the ⏻ (on/standby) switch to turn on the ⏻ (on/standby) indicator in yellow green.
	<ul style="list-style-type: none"> • Does the firmware of your digital camera support the printer? 	<ul style="list-style-type: none"> ➔ See the homepage for the digital camera you are using.
	<ul style="list-style-type: none"> • Is the PICTBRIDGE indicator of the printer flashing? 	<ul style="list-style-type: none"> ➔ If a USB mouse or other non-PictBridge-compliant device is connected, remove it and connect a PictBridge-compliant device. ➔ Disconnect the digital camera and the printer and then connect them again. Or turn off and then on the printer and the digital camera.
	<ul style="list-style-type: none"> • Is printing in process? 	<ul style="list-style-type: none"> ➔ Connect the cable again after printing is complete.
	<ul style="list-style-type: none"> • Is the printer connected to the PC? 	<ul style="list-style-type: none"> ➔ You cannot connect a PictBridge-compliant digital camera and the PC to the printer at the same time. Remove the USB cable of the PC and connect the digital camera again to the printer.

Symptom	Check	Cause/Solutions
An error is displayed with the digital camera and you cannot make printing.	<ul style="list-style-type: none"> • Are you using the identical type of print paper and print cartridge? 	→ Insert the print paper whose type is identical with the print cartridge loaded. To change the type of the print cartridge, postpone printing, replace print cartridges, and then resume printing.
You cannot make a DPOF printing.		→ Some types of digital cameras do not support DPOF printing. Use another method for printing.

Connecting with a computer

Symptom	Check	Cause/Solutions
You lost the supplied CD-ROM and want to obtain a new one.		→ Please download the printer driver from the Customer support home page (→ page 46). Or contact your Sony dealer.
The printer driver cannot be installed.	<ul style="list-style-type: none"> • Are you sure that you have followed the installation procedures correctly? 	→ Follow the procedures in the operating instructions to install the driver (→ page 20). If an error occurs, restart your computer and do the installation procedures again.
	<ul style="list-style-type: none"> • Is another application program running? 	→ Exit all applications and then install the driver again.
	<ul style="list-style-type: none"> • Did you specify the CD-ROM as the installation CD-ROM correctly? 	→ Double-click My Computer, and then the CD-ROM icon in the open window. Follow the procedures in the operating instructions to install the driver.
	<ul style="list-style-type: none"> • Is the USB driver installed? 	→ The USB driver may not be installed properly. Follow the operating instructions to install the USB driver again.

Symptom	Check	Cause/Solutions
The printer driver cannot be installed.	<ul style="list-style-type: none"> • Can you read the CD-ROM with Explorer? 	<p>→ If there is an error with the CD-ROM, you may not be able to read it. If an error message is displayed on your PC, check the contents and remove the source of the problem. Then install the printer driver again. For details on the error contents, see the operating instructions of your PC.</p>
	<ul style="list-style-type: none"> • Is there an anti-virus program or other program running on the system? 	<p>→ If there is an anti-virus program or other program running on the system, exit it and then start installing the driver.</p>
	<ul style="list-style-type: none"> • Did you log onto Windows XP/2000 Professional using an Administrator user account? 	<p>→ To install the driver in Windows XP/2000 Professional, log onto Windows using an Administrator user account.</p>
The printer does not respond to the printing order from the PC.		<p>→ Check if the ERROR indicator of the printer lights or flashes. If it does, do the following procedures, which may solve the problem:</p> <ol style="list-style-type: none"> 1 Turn off and then on the printer. 2 Disconnect the AC power adaptor from the printer. 3 Wait for 5 to 10 seconds, and then connect the AC adaptor again. 4 Restart your computer. <p>If these do not solve the problem, consult with your Sony dealer or service facilities.</p>
	<ul style="list-style-type: none"> • Is an error message displayed stating that an error was detected in output of documents via USB? 	<p>→ Remove the USB cable and then connect it again.</p>
	<ul style="list-style-type: none"> • Is a PictBridge-compliant digital camera connected to the printer? 	<p>→ You cannot connect a PictBridge-compliant digital camera and the PC to the printer at the same time. Remove the cable from the PICTBRIDGE connector and connect the PC again to the printer.</p>

Symptom	Check	Cause/Solutions
An image is printed with borders even if I select borderless print option.	<ul style="list-style-type: none"> • Are you using an application software other than Picture Motion Browser? 	<p>→ When using an application other than the Picture Motion Browser, an image might be printed with borders even if you select borderless print. If this occurs, do either of the following to print an image without borders:</p> <ul style="list-style-type: none"> – When you can set print range with an application, set an image to be printed fully in the print range even if it is printed over the range. – Set a larger value in the “Enlarge/Reduce” text box in the “Paper/Output” tab of the “Sony DPP-FP35 Properties” dialog box. (→ page 28) – If borders remain on the right and bottom sides of a printed image even after you set a larger value, check “Upper left reference”.
An image is not printed in correct colors.	<ul style="list-style-type: none"> • Is “Exif Print” checked in the “Graphics” tab of the “Sony DPP-FP35 Properties” dialog box? 	<p>→ The Exif Print setting in the “Color reproduction/Picture quality” section supports the Picture Motion Browser only. To print from other application, uncheck “Exif Print”.</p>
	<ul style="list-style-type: none"> • Is “ICM” selected in the “Graphics” tab of the “Sony DPP-FP35 Properties” dialog box? 	<p>→ The ICM setting may be valid only when you are using an ICM-compliant application. Check to see if the application software you are using supports ICM.</p>
Preview image does not reflect the print settings in the “Graphics” tab of the “Sony DPP-FP35 Properties” dialog box.	/	<p>→ The print settings adjust the printer itself and cannot influence the preview image.</p>
Print quantity specified in the “Paper/Output” tab of the “Sony DPP-FP35 Properties” dialog box does not take effect.	/	<p>→ Depending on the application software you use, the print quantity setting of the application software may have priority over the setting specified in the printer driver dialog box.</p>

Printing

When you place print paper in the paper tray and start printing, paper feeding error may occur: the printer does not feed paper; the printer may feed overlapped paper; or the printer may feed paper diagonally. If this occurs, check the items listed in the following symptom "Paper does not feed".

Symptom	Check	Cause/Solutions
Paper does not feed.	<ul style="list-style-type: none"> • Is the print paper properly set in the paper tray? 	<p>→ If print paper is not properly loaded, the printer may develop trouble. Check the following:</p> <ul style="list-style-type: none"> • Is the correct set of print paper and print cartridge loaded? (→ page 11) • Is the print paper inserted in the correct direction? • Did you place more than 20 sheets of print paper in the paper tray? (→ page 14) • Did you riffle the print paper thoroughly? • Did you bend or fold the print paper before printing? <p>→ If print paper runs out during continuous printing or if you print with no print paper in the paper tray, the printer's ERROR indicator lights. Feed the print paper without turning off the power and resume printing.</p>
	<ul style="list-style-type: none"> • Are you using print paper that was not designed for the printer? 	<p>→ Use print paper designed for the printer. If you use incompatible print paper, the printer may develop trouble. (→ page 11)</p>
	<ul style="list-style-type: none"> • Is the print paper jammed? 	<p>→ When the printer cannot feed the print paper, the ERROR indicator flashes rapidly. Remove the paper tray and check paper jam. (→ page 42)</p>
The print paper emerges during printing in process.	<ul style="list-style-type: none"> • Is it in the middle of the printing process? 	<p>→ The print paper may emerge a few times during printing. Do not touch nor pull the emerged paper. Wait for the print paper to be fully ejected after printing ends. As the print paper emerges from the rear a few times during printing, make sure to spare enough space behind the printer during printing.</p>

Printed results

Symptom	Check	Cause/Solutions
The printed pictures are inferior in quality.	<ul style="list-style-type: none"> • Did you print preview image data? 	<p>→ When a digital camera saves an image, a preview image may be saved along with the primary images. The printed quality of the preview images will not be as good as the primary images. Note that if you delete the preview images, the data for the primary images may be damaged.</p>
	<ul style="list-style-type: none"> • Did you allow dust to get on the print cartridge? 	<p>→ Wipe the plastic part of the print cartridge and remove dust.</p>
	<ul style="list-style-type: none"> • Did you allow dust or finger prints to get on the printed surface? 	<p>→ Do not touch the printing surface (the shiny-side with no imprint). Fingerprints on the printing surface may result in imperfect printing.</p>
	<ul style="list-style-type: none"> • Did you use used print paper? 	<p>→ Do not print on used print paper. Printing an image twice on the same paper will not make the printed image thicker. Doing so could result in damages to the printer.</p>
	<ul style="list-style-type: none"> • Did you use an AdobeRGB-compliant digital camera, not compatible with the DCF 2.0, to shoot an image in the AdobeRGB mode? 	<p>→ An AdobeRGB image file that supports the DCF 2.0 will undergo color corrections, but an AdobeRGB image file that does not support the DCF 2.0 will be printed in vague colors without color corrections.</p> <p>What is an AdobeRGB?</p> <p>An AdobeRGB is a color space that the Adobe Systems Incorporated employs and uses as the default setting for image processing software including the Adobe Photoshop. The AdobeRGB, an optional color space extended with the DCF 2.0, determines the color ranges widely used in printing industry.</p> <p>For whether or not a digital camera supports the AdobeRGB, see the operating instructions of the digital camera.</p>

Symptom	Check	Cause/Solutions
The picture quality and colors of the image previewed on the screen of the digital camera differ from those printed.		→ Because of differences in the phosphor method or profiles of a monitor or LCD screen, please regard the image being displayed on the screen as just a reference.
The image cannot be printed fully in the print range.	<ul style="list-style-type: none"> • Is the aspect ratio of the image correct? 	→ Depending on the type of digital camera used, the aspect ratio of the recorded image differs, so the image may not be printed covering the entire printable area.
The image is stretched horizontally when printed.	<ul style="list-style-type: none"> • Did you rotate the image or add other process? 	→ Depending on the type of digital camera used, the image may be stretched vertically if it has been rotated or processed using your digital camera. This is not because of trouble with the printer, but because the image was rewritten with your digital camera.
The image is printed at an angle.	<ul style="list-style-type: none"> • Is the paper tray inserted properly? 	→ Re-insert the paper tray firmly straight in to the end.

Others

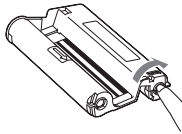
Symptom	Check	Cause/Solutions
I cannot insert the print cartridge smoothly.		<p>→ If the print cartridge does not click into place, remove it and then re-insert it. Only when the ink ribbon is too slack to be loaded, wind the ink ribbon in the direction of the arrow to remove the slack. (→ page 13)</p> 
The print cartridge cannot be removed.		<p>→ Keep the paper tray inserted and turn off the ⏻ (on/standby) switch and then turn it on. After the initial motion stops, try to remove the cartridge. If this does not solve the problem, contact Sony service facilities or your Sony dealer.</p>
The print paper is not ejected.	<ul style="list-style-type: none"> • Is the ERROR indicator flashing rapidly? 	<p>→ Paper is jammed. See “If paper jams” (→ page 42) and remove jammed paper from the printer. If jammed paper cannot be removed, contact the Sony service facilities.</p>
	<ul style="list-style-type: none"> • Does the ERROR indicator light? 	<p>→ Remove the print paper and resume printing. If you cannot remove the print paper, follow the procedures shown in “If paper jams” (→ page 42) and remove jammed paper from the printer.</p>
Printing stops midway.	<ul style="list-style-type: none"> • Is the ERROR indicator flashing rapidly? 	<p>→ Paper is jammed. See “If paper jams” (→ page 42) and remove jammed paper from the printer. If jammed paper cannot be removed, contact the Sony service facilities.</p>

If paper jams

If the print paper jams, the ERROR indicator lights or flashes rapidly and printing stops.

When the ERROR indicator lights, remove the print paper and resume printing.

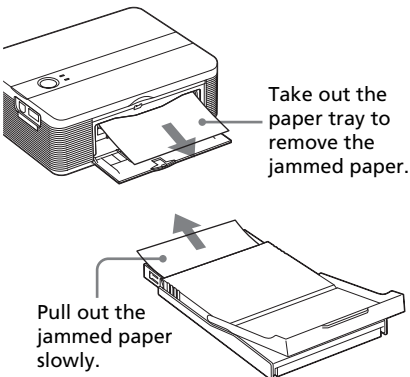

When the ERROR indicator flashes rapidly, turn off the power with the paper tray and print cartridge loaded. Then turn on the printer again. When the printer's initial loading process ends, remove the paper tray from the printer. Check if there is jammed paper in the paper outlet or feeding slot of the printer and remove the jammed paper, if any.



Note

If you cannot remove the jammed paper, contact your Sony dealer or service facilities.

To turn off the printer

Keep pressing the  (on/standby) switch for longer than one second until the  (on/standby) indicator turns to red.

Cleaning the inside of the printer

If white lines or periodical dots are printed on the pictures, use the cleaning cartridge supplied and the protective sheet of the supplied printing pack to clean inside the printer.

Tip

You can also use the protective sheet supplied in the optional printing pack.

Make sure that the digital camera and the computer are disconnected from the printer.

- 1 Open the cartridge compartment door and if there is a print cartridge, remove it (page 12).
- 2 Insert the supplied cleaning cartridge into the printer and close the cartridge compartment door.

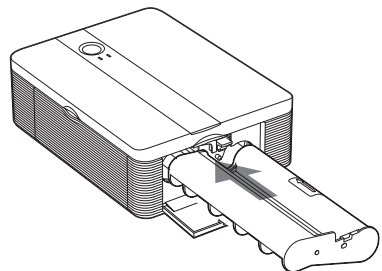

- 3 Remove the paper tray from the printer. If there is print paper in the tray, remove the print paper from the tray.

4 Place the protective sheet into the paper tray.

Insert the protective sheet with the no-imprint side facing up.

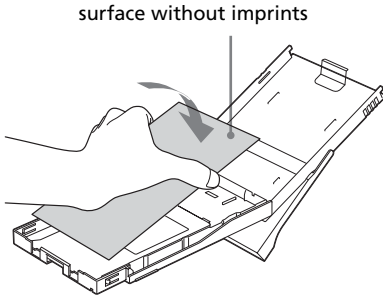

5 Set the paper tray into the printer and press the ⏻ (on/standby) switch.

The cleaning cartridge and protective sheet will clean inside the printer. The ⏻ (on/standby) indicator flashes slowly in green. After the cleaning is finished, the protective sheet is automatically ejected.

6 Remove the cleaning cartridge and protective sheet from the printer.

Tips

- Keep the cleaning cartridge and protective sheet together for future cleaning.
- With a protective sheet, you can carry out cleaning for the maximum of about 20 times.

When cleaning ends

Set the print cartridge and print paper into the printer.

Notes

- Carry out cleaning only when there are white lines or dots on the print.
- When you can obtain proper printing performances, cleaning will not improve the printed picture quality.
- The maximum cleaning times that you can carry out is approximately 20. As the number of cleaning times increases, the cleaning loses its effect.
- Do not place the protective sheet on the print paper and carry out cleaning, which may cause paper jam or other troubles.
- If a cleaning does not improve printed picture quality, please carry out cleaning a couple of times.

Precautions

On safety

- Be careful not to set or drop any heavy objects on the power cord, or to damage the power cord in any way. Never operate this printer with a damaged power cord.
- Should any solid object or liquid fall into the cabinet, unplug the printer and have it checked by qualified personnel before operating it any further.
- Never disassemble the printer.
- To disconnect the power cord, pull it out by the plug. Never pull the power cord itself.
- When the printer is not going to be used for an extended period of time, disconnect the power cord from the wall outlet.
- Do not handle the printer roughly.
- To reduce the risk of electrical shock, always unplug the printer from the electrical outlet before cleaning and servicing the printer.

On installation

- Avoid placing the printer in a location subject to:
 - vibration
 - high humidity
 - excessive dust
 - direct sunlight
 - extremely high or low temperatures
- Do not use electrical equipment near the printer. The printer will not work properly in electromagnetic fields.
- Do not place heavy objects on the printer.
- Leave enough room around the printer so that the ventilation holes are not blocked. Blocking these holes may cause internal heat build-up.

On the AC adaptor

- Be sure to use the AC adaptor supplied with the printer. Do not use other AC adaptors, as this may cause a malfunction.
- Do not use the supplied AC adaptor to other devices.
- Do not use an electrical transformer (travel converter), as this may cause overheat or a malfunction.
- In case the cord of the AC adaptor is damaged, never use it any longer, as this may cause danger.

On moisture condensation

If the printer is brought directly from a cold location to a warm location or placed in an extremely warm or humid room, moisture may condense inside the unit. In such cases the printer will probably not work properly and may even develop a fault if you persist in using it. If moisture condensation occurs, unplug the AC power cord of the printer and do not use the printer for at least one hour.

On transport

When you transport the printer, remove the print cartridge, paper tray or AC adaptor, from the printer and put the printer and its peripherals in the original box with the protective packaging.

If you no longer have the original box and packing parts, use similar packing material so that the printer will not be damaged while being transported.

On cleaning

Clean the cabinet, panel and controls with a soft dry cloth, or a soft cloth lightly moistened with a mild detergent solution. Do not use any type of solvent, such as alcohol or benzine, which may damage the finish.

On restrictions on duplication

If duplicating documents with the printer, pay special attention to the following:

- Duplication of banknotes, coins, or securities is against the law.
- Duplication of blank certificates, licenses, passports, private securities, or unused postal stamps is also against the law.
- TV program, films, video tapes, others' portraits or other materials may be copyrighted. Unauthorized video printing of such materials may infringe the provisions of the copyright law.

Specifications

■ Printer

Printing method

Dye sublimation printing (Yellow/Magenta/Cyan 3 pass)

Resolution

300 (H) x 300 (V) dpi

Equivalent to
3 color Ink-Jet 4800 dpi x 4800 dpi^{*1}
6 color Ink-Jet 3810 dpi x 3810 dpi^{*2}

Image processing per dot

256 levels (8 bits for each Yellow/Magenta/Cyan), approx. 16 770 000 colors

Printing size

Post Card (4 x 6 inch/10 x 15 cm) size:
101.6 x 152.4 mm (maximum, borderless)

Printing time (per sheet)^{*3}

PictBridge mode^{*4}: Approx. 77 seconds
PC mode^{*5}: Approx. 60 seconds

Input/Output connectors

USB for PC connection USB 1.1 (Type B)
Highspeed is not supported.
PictBridge connector

Compatible image file formats

JPEG: DCF 2.0 compatible, Exif 2.21 compatible, JFIF^{*6}
Some image file formats are not compatible.

Continued

Maximum number of pixels to be handled

10 000(H) x 7 500(V) dots

Print cartridge/Print Paper

See "Preparing the print pack" on page 11.

Power requirements

DC IN jack, DC 24 V
(On standby mode, less than 1W)

Operating temperature

5 °C to 35 °C (41 °F to 95 °F)

Dimensions

Approx. 175 x 60 x 137 mm
(7 x 2³/₈ x 5¹/₂ inches)
(w/h/d, excluding protruding parts)
(306 mm (12¹/₈ inches) of depth when the paper tray is installed.)

Mass

Approx. 1 kg (2 lb 3 oz)
(excluding the paper tray, print cartridge, AC power adaptor)

Supplied accessories

See "Checking the contents of the package" on page 10.

■ AC power adaptor AC-S2425

Power requirements

AC 100 to 240 V, 50/60 Hz, 1.5 to 0.75 A

Rated output voltage

DC 24 V, 2.2 A

Operating temperature

5 °C to 35 °C (41 °F to 95 °F)

Dimensions

Approx. 60 x 30.5 x 122 mm
(2³/₈ x 1¹/₄ x 4⁷/₈ inches)
(w/h/d, excluding protruding parts)

Mass

Approx. 300 g (11 oz)

Design and specifications are subject to change without notice.

- *1: When the 16 x 16 matrix is used: 300 x 16 = 4,800 dpi
- *2: When the 12.7 x 12.7 matrix is used: 300 x 12.7 = 3,810 dpi
- *3: When photo of 3.11MB file size is taken by DSC-T30 (7Mega Cyber-shot)
- *4: Time from when the print button on the display window of the camera is pressed to when printing is finished via DSC-T30 connected by USB cable.
- *5: The time for data processing and transferring is excluded.
- *6: Baseline JPEG with 4:4:4, 4:2:2, or 4:2:0 format

Customer support home page



The latest support information is available at the following home page address:

<http://www.sony.net/>

Printing range

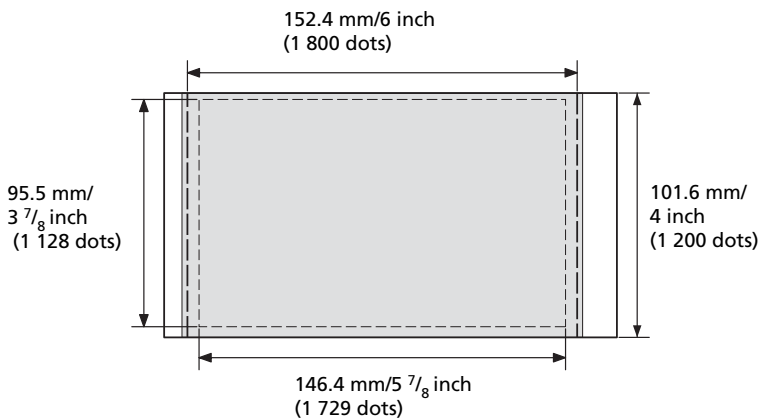
Post card size



-  Border print range
-  Borderless print range
-  Perforations

The above illustrations are those when an image from a PC is printed. The printing range differs for a border or a borderless print.

Glossary

Auto Fine Print 3

The function automatically corrects the picture quality so that an image may be printed in more vivid, clear and beautiful pictures. It is especially effective for a darker image with low contrast. The pictures are corrected to reproduce natural skin colors, vivid tree leaf green, or clear sky blue.

DCF (Design rule for Camera File system)

This camera conforms with the DCF (Design rule for Camera File system) standard established by JEITA (Japan Electronics and Information Technology Industries Association) to maintain file exchangeability and compatibility between digital cameras and related products. Complete exchangeability and compatibility, however, are not guaranteed.

DPOF (Digital Print Order Format)

The format used to record the information necessary for automatically printing images shot by a digital camera at a printing shop or with a home-use printer. The printer supports DPOF printing and can automatically print the preset number of copies of the DPOF preset images.

Exif 2.21 (Exif Print)

Exif (Exchangeable image file format for digital cameras) Print is a global standard for digital photo printing. A digital camera supporting Exif Print stores the data relevant to the conditions of shooting as each shot is taken. The printer utilises the Exif Print data stored in each image file to ensure the printed result matches the original shot as closely as possible^{*1}.

- *1 When the "Auto Fine Print 3" is enabled and an image (JPEG file) is shot by an Exif Print (Exif 2.21)-compliant digital camera, the image is automatically adjusted to its optimum picture quality and printed.

PictBridge

A standard specified by Camera & Imaging Products Association that allows you to connect PictBridge-complaint digital camera directly to the printer without a PC, enabling direct printing on the spot.

Index

A

- AC adaptor 16
- AC power cord 16
- Auto Fine Print 3 7, 48

B

- Borders/borderless print 27

C

- Cartridge compartment door 12
- Cleaning 42
- Connecting
 - Computer 21
 - PictBridge-compliant digital camera 17
 - To AC outlet 16

D

- DC IN 24V 16
- DPOF (Digital Print Order Format) 48

E

- Eject lever 12
- Enlarge/reduce 28
- ERROR indicator 12, 36, 38, 41
- Exif Print 7, 27, 29, 48

I

- Inserting
 - Print cartridge 12
 - Print paper 13
- Installing
 - Picture Motion Browser 23
 - Printer driver 20
 - System requirements 19

M

- Moisture condensation 44

O

- On/standby indicator 16, 17, 42
- On/standby switch 17, 42
- Overview 6

P

- Paper jams 42
- Paper tray 13
- Paper tray lid 13
- PC mode 6, 19
- PictBridge camera 6, 17
- PictBridge connector 17
- PICTBRIDGE indicator 18
- Picture Motion Browser 19
- Precautions 44
- Preview 30

- Print cartridge 12
- Print pack 11
- Print paper 11, 13
- Printing
 - From a PC 19
 - From a PictBridge camera 17
- Printing range 47

R

- Red-eye phenomenon 29
- Restrictions on duplication 45

S

- Specifications 45
- Stop printing 32
- Super Coat 2 7
- Supplied accessories 10
- System requirements 19

T

- Transport 44
- Troubleshooting 34

U

- Uninstalling
 - Picture Motion Browser 25
 - Printer driver 22
- USB connector 21

Free Manuals Download Website

<http://myh66.com>

<http://usermanuals.us>

<http://www.somanuals.com>

<http://www.4manuals.cc>

<http://www.manual-lib.com>

<http://www.404manual.com>

<http://www.luxmanual.com>

<http://aubethermostatmanual.com>

Golf course search by state

<http://golfingnear.com>

Email search by domain

<http://emailbydomain.com>

Auto manuals search

<http://auto.somanuals.com>

TV manuals search

<http://tv.somanuals.com>