

Digital Photo Printer

Operating Instructions



UP-D75

Owner's Record

The model and serial numbers are located at the rear. Record these number in the space provided below. Refer to these numbers whenever you call upon your Sony dealer regarding this product.

Model No. _____

Serial No. _____

WARNING

To reduce the risk of fire or electric shock, do not expose this apparatus to rain or moisture.

To avoid electrical shock, do not open the cabinet. Refer servicing to qualified personnel only.

THIS APPARATUS MUST BE EARTHED.

To disconnect the main power, unplug the AC IN connector.

For the customers in the U.S.A.

This equipment has been tested and found to comply with the limits for a Class A digital device, pursuant to Part 15 of the FCC Rules. These limits are designed to provide reasonable protection against harmful interference when the equipment is operated in a commercial environment. This equipment generates, uses, and can radiate radio frequency energy and, if not installed and used in accordance with the instruction manual, may cause harmful interference to radio communications. Operation of this equipment in a residential area is likely to cause harmful interference in which case the user will be required to correct the interference at his own expense.

You are cautioned that any changes or modifications not expressly approved in this manual could void your authority to operate this equipment.

All interface cables used to connect peripherals must be shielded in order to comply with the limits for a digital device pursuant to Subpart B of Part 15 of FCC Rules.

Warning on power connection

Use a proper power cord for your local power supply.

1. Use the approved Power Cord (3-core mains lead) / Appliance Connector / Plug with earthing-contacts that conforms to the safety regulations of each country if applicable.
2. Use the Power Cord (3-core mains lead) / Appliance Connector / Plug conforming to the proper ratings (Voltage, Ampere).

If you have questions on the use of the above Power Cord/Appliance Connector/Plug, please consult a qualified service personnel.



As an ENERGY STAR Partner, Sony Corporation has determined that this product meets the ENERGY STAR guidelines for energy efficiency.

Outline of the International ENERGY STAR Office Equipment Program

The International ENERGY STAR Office Equipment Program is an international program that promotes energy saving through the use of computers and other office equipment. The program backs the development and dissemination of products with functions that effectively reduce energy consumption. It is an open system in which business proprietors can participate voluntarily. The targeted products are office equipment such as computers, displays, printers, facsimiles, and copiers. Their standards and logos are uniform among participating nations.

Table of Contents

Introduction

Features	4
System Configuration	4
Location and Function of Parts and Controls	4
Front	4
Rear	5

Preparation

Supplied Accessories	6
Assembly	6
Connections	7
Installing the Printer Driver	7
USB Port Connection	7

Operation

Before Printing	8
Loading an Ink Ribbon Cassette	8
Loading the Paper	9
Printing	11
Setting the Print Quantity	12
Adjusting the Printouts	13
Adjusting the Gray Balance	14

Miscellaneous

Precautions	15
Safety	15
Installation	15
On Transportation	15
Cleaning	15
Ink Ribbon and paper	17
Specifications	18
Troubleshooting	19
Error Messages	19
If the Paper Jams	19
Index	21

Features

The UP-D75 Digital Photo Printer is a dye sublimation thermal transfer printer providing high quality, high resolution (300 dpi), and high speed printing of computer image data on A4 size paper in full color (256 gradations process and 16.7 million colors).

System Configuration

The following shows an example printer system configuration.

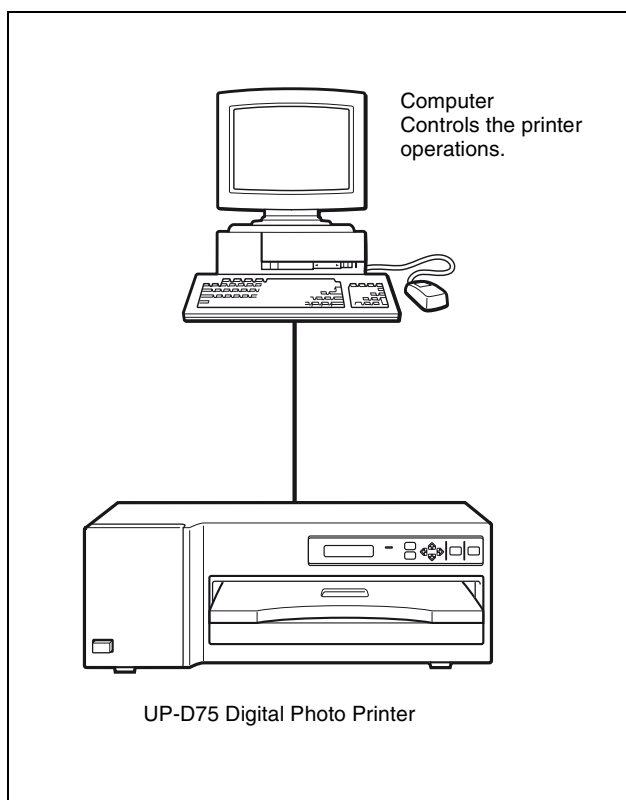

Location and Function of Parts and Controls

For details, refer to the pages indicated in parentheses.

Front

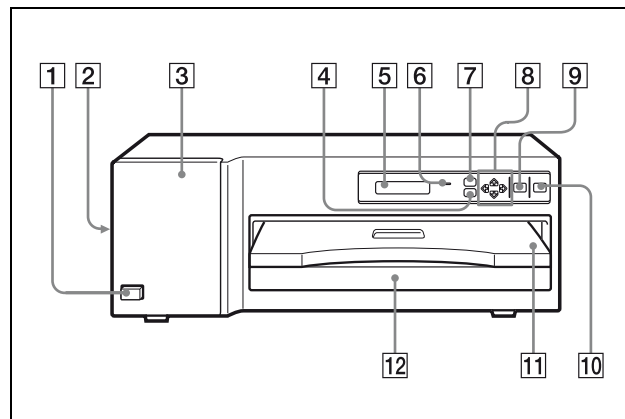

- 1 ①POWER switch**
Press to turn the printer on or off.
- 2 Fan cover (6, 16)**
Provided to prevent the printer from dust.
- 3 Ribbon door (8)**
Pull the tab (marked with PULL) on the top on the ribbon door to open it when loading an ink ribbon cassette.
- 4 PRINT QTY (quantity) button (12)**
Press this button to display or close the print quantity setting menu in the printer window display.
- 5 Printer window display**
Displays the status messages. In menu operation, the print quantity setting menu, printout adjust menu or gray balance adjust menu is displayed. If an error occurs, a corresponding error message is displayed.
- 6 ALARM indicator (19)**
Lights in orange when the ink ribbon or paper is exhausted, the paper jams, or another problem occurs.
- 7 MENU button (13)**
Press this button to display or close the printout adjust menu in the printer window display.

- 8 Cursor control buttons (12, 13, 14)**
Use these buttons to increase or decrease a value and level shown on the menu, or scroll up and down through a menu.
- 9 CAL (Calibration) button (14)**
Press this button to adjust the gray balance.
- 10  PRINT button (11, 14)**
Press this button to print the image data stored in the memory of the printer.
- 11 Paper cover (6)**
Printouts are ejected here.
- 12 Paper tray (6)**
Load paper here. Press the point marked with PUSH to remove the paper tray.

Rear

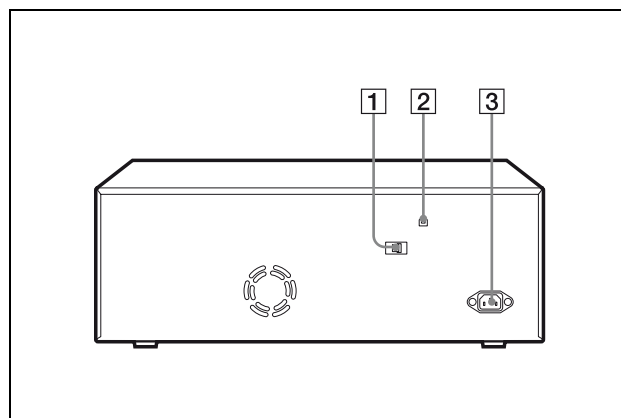

- 1 Cable stopper (7)**
Fixes the USB cable to prevent it from being disconnected.
- 2 USB connector (7)**
Connects to a computer equipped with the USB interface (which conforms to USB 2.0), using a USB cable (not supplied).
- 3 ~AC IN connector (7)**
Used to connect to a wall outlet, using the AC power cord supplied.

Preparation

Supplied Accessories

This printer is packed together with the following accessories. Check that nothing is missing from your package.

Paper tray (1)

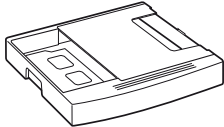

Paper cover (1)



Ink ribbon holder (1)

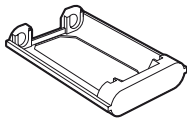

Bottom cover (1)

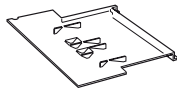

Fan cover with a filter (1)

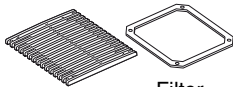

Fan cover

Filter

Thermal Head Claning Kit (1)
AC power cord (1)
CD-ROM (1)
Ferrite core (1)
Operating Instructions (1)
Warranty Card (1)
Software License Agreement (1)

Assembly

Mount the supplied ink ribbon holder, paper tray, paper cover, bottom cover and fan cover.

Note

You cannot mount the ink ribbon holder when the thermal head is locked.

Before assembling, turn on the power of the printer. The thermal head is unlocked and you can mount the ink ribbon holder.

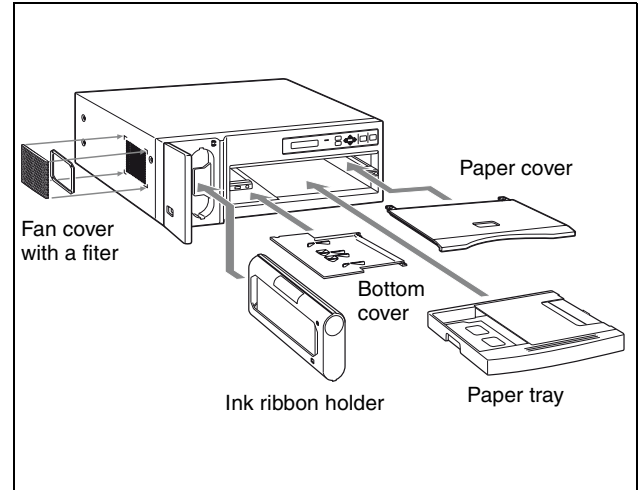

Note

Retain the original carton and packing materials in case you have to transport this unit in the future.

Connections

After connecting a USB connecting cable (not supplied) to the printer and the computer, connect the power cord. For details about the printer connection, refer to the manuals for the computer or other peripheral devices.

Installing the Printer Driver

Install the printer driver provided with the printer. For detailed instructions on how to install the printer driver, refer to the Readme.txt file and the install manual contained on the CD-ROM disc supplied.

USB Port Connection

Notes

- Follow the connection procedures described in the computer manual.
- Make sure that the interface cable is connected securely at both ends.
- The printer drive software provided with the printer is not suitable for using the printer connected to a network.
- Operation of the printer is not guaranteed for connection to a USB hub.
- Before connecting the unit using a USB cable (not supplied), attach a supplied ferrite core to the end of the cable to be connected to the printer for noise prevention. For detailed information on how to attach the ferrite cores, see “Attaching a ferrite core to a USB cable” on page 7.

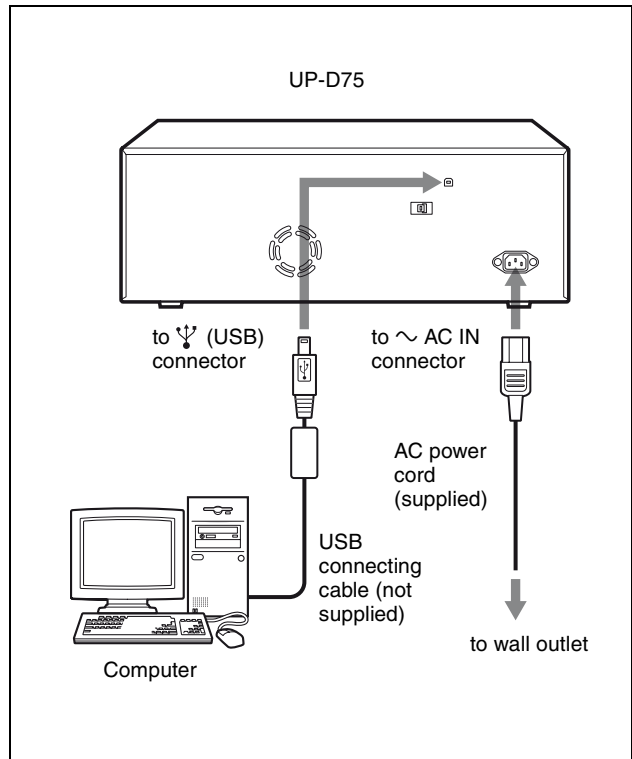

Attaching a ferrite core to a USB cable

Before connecting a USB cable (not supplied) to the printer, you should attach a supplied ferrite core to its cable for noise prevention. To conform to radiation standards, attach the supplied ferrite core to the USB cable of your device as described below.

- 1 Release two stoppers on the ferrite core to open it.
- 2 Slip the USB cable through the ferrite core and position it at the base of the USB connector to the printer.
- 3 Close the ferrite core until you hear a click.

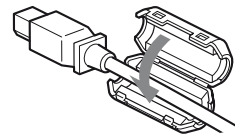

Note

When the ferrite core cannot be secure because the USB cable is thin, secure it using a tape.

Securing a USB cable

After you connect a USB cable to the printer, it is recommended that you secure the USB cable to prevent it from being accidentally disconnected using the cable stopper.

Before Printing

This section describes the operations that must be performed prior to starting printing. This explanation assumes that the printer has already been installed and that all connections have been made.

- Loading an ink ribbon cassette (on this page)
- Loading the paper (page 9)

Once these operations have been completed, there should be no need to perform them again during routine printing.

Notes

- When replacing the ink ribbon or paper, do not turn off the power. Turning off the power will cause the image stored in the memory to be lost.
- After replacing the ink ribbon or paper, perform the gray balance adjustment. (See “Adjusting the Gray Balance” on page 14.)
- Use the ink ribbon suitable for the type of print material. Before attempting to load an ink ribbon, make sure that the combination of the ribbon and paper is compatible. (See “Ink Ribbon and paper” on page 17.)
- **Use only ink ribbon and paper designed for use with this printer. Failing to do so is likely to result in unsatisfactory printing or malfunctions.** (See “Ink Ribbon and paper” on page 17.)

Loading an Ink Ribbon Cassette

Load the ink ribbon to the supplied ink ribbon holder, and load the ink ribbon cassette (referring to the ink ribbon holder loaded with the ink ribbon) to the printer's ribbon compartment.

Notes

- When you use the printer at the first time, the thermal head was locked at the factory. Turn on the printer first to unlock the thermal head, then start to load an ink ribbon cassette.
- Once an ink ribbon has been completely used, replace it. Ink ribbons are not reusable.
- Do not rewind the ink ribbon for reuse.
- Do not touch the ink ribbon or place it in a dusty location. Finger prints or dust on ink ribbon will result in imperfect printing.

- 1 Open the ribbon door by pulling the tab on the ribbon door and marked with PULL.

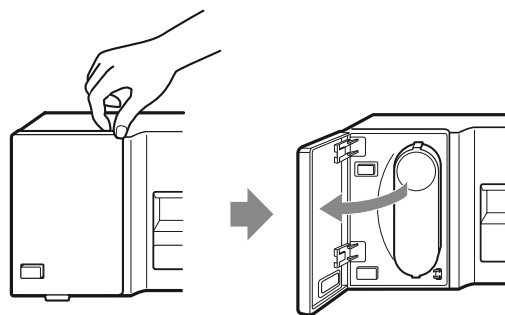

- 2 Remove the ink ribbon cassette by pressing the EJECT button. The ink ribbon cassette pops out.

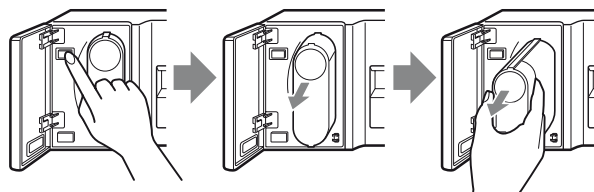

Note

Never put your hand into the ink ribbon compartment. The thermal head becomes very hot. You may burn yourself if you touch it.

- 3 Detach the used ink ribbon from the ink ribbon holder.

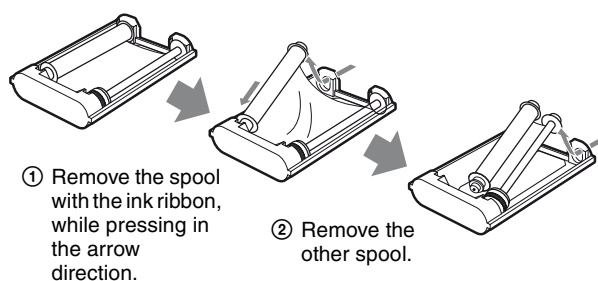

4 Load the ink ribbon to ink ribbon holder.

- 1 Load the spool holding the ink ribbon into the right-hand part of the holder, while pressing in the arrow direction.

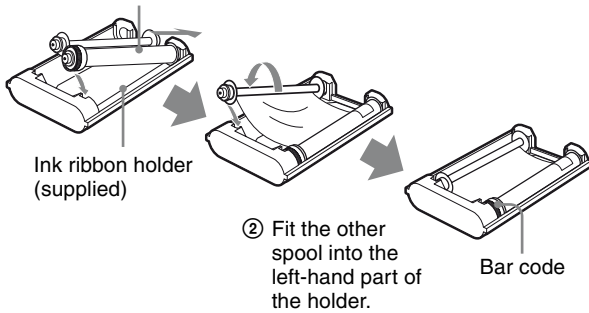

5 Remove any slack from the ink ribbon. If the ribbon is left slack, it may be crumpled and damaged when inserted.

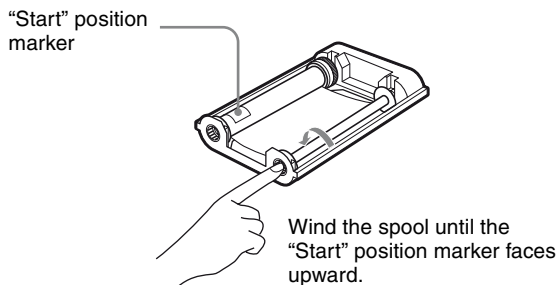

6 Insert the ink ribbon cassette firmly until it stops.

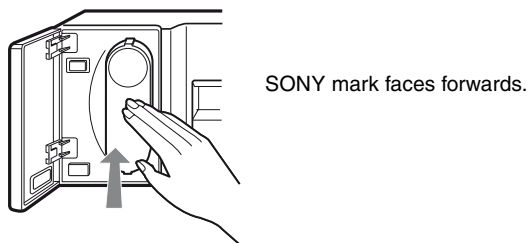

7 Close the ribbon door.

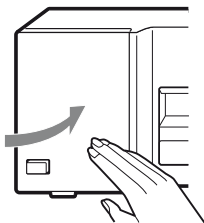

If your ink ribbon should tear

Repair the tear with transparent tape. There should be no problem with using the remaining portion of the ribbon.

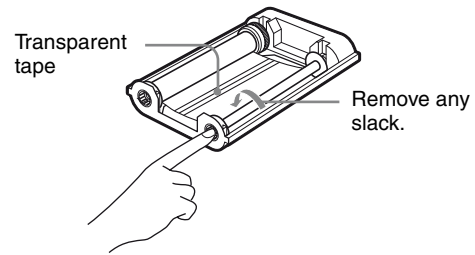

Notes When storing ink ribbons

- Avoid placing the ink ribbon in a location subject to:
 - high temperatures
 - high humidity
 - excessive dust
 - direct sunlight
- Store partially used ink ribbon in its original package.

Loading the Paper

Load the paper by the following procedure. Be careful not to touch the printing surface of the paper.

Note

When loading the paper, do not turn off the power. If you turn off the power, the image data stored in the memory will be lost.

- 1 Press PUSH on the paper tray. The paper tray is ejected.

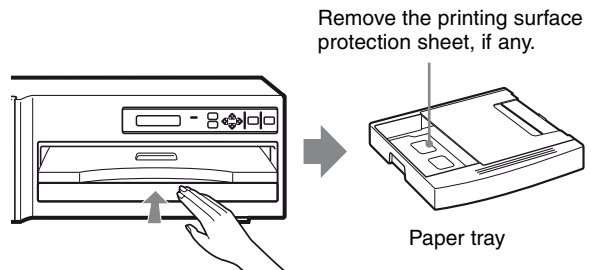

- 2** Open the tray cover and place the paper in the paper tray.

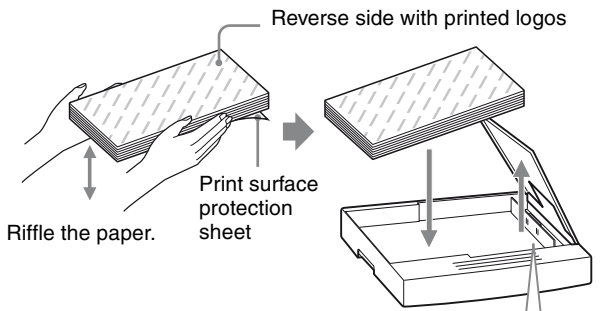

Place the paper in the paper tray with the printing surface (shiny side with no legends) and its protection sheet facing down.

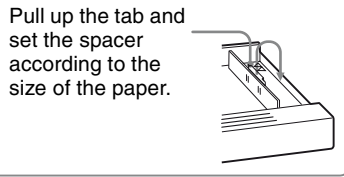

Notes on storing paper

- Avoid storing the paper in a location subject to:
 - high temperatures
 - high humidity
 - excessive dust
 - direct sunlight
- Use the original package for storing unused paper.

Notes

The number of the paper is the same as the number of the paper that one roll of the ink ribbon can afford. Usually the ink ribbon and paper have run out at the same time. However, even when either the ink ribbon or the paper has run out, replace both the ink ribbon and the paper with new ones. When you load the paper, pay attentions to the following.

- The paper tray holds up to the total number of sheets contained in a package sheets of paper. If you exceed this limit, paper jams may occur. Also, do not place different types of paper in the tray. If you do, paper jams may occur.
- If you load the paper that is not compatible with the ink ribbon used, the gray balance may be changed.
- Load the paper so that it lays flat in the paper tray. If the paper is curled, it will overflow the paper tray and the printing position may shift. If this happens, load fewer sheets in the paper tray.
- Set the spacer according to the size of the paper, and then place the paper in the paper tray. Doing so may cause a paper jam or malfunction.

- 3** Close the tray cover and slide the paper tray into the printer until it clicks into place.

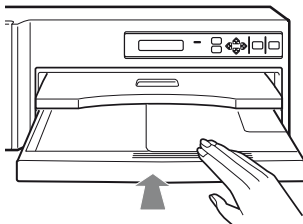

Printing

Before printing

- Ensure that the printer is properly connected to the computer (page 7).
- Ensure that the combination of the ink ribbon and paper is correct (pages 8 and 9).
- Ensure that the ink ribbon cassette and paper are properly loaded (page 17).

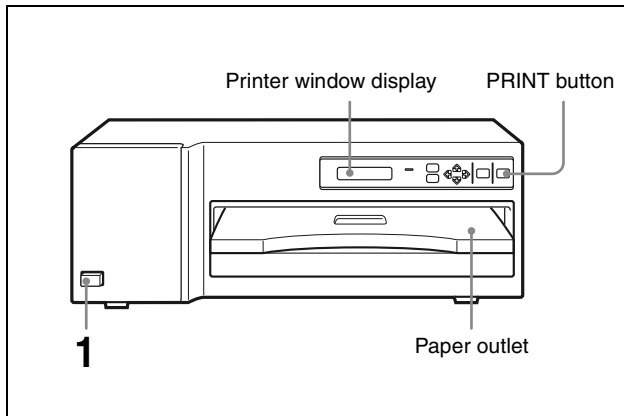

- 1 Turn on the power of the printer and computer. When the printer is in standby status, the following message appears in the printer window display.

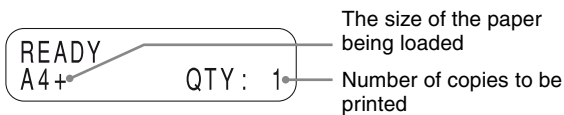

- 2 Send the image data from the computer to the printer. For details, also see the ReadMe file on the supplied CD-ROM.

- ① While the printer is receiving the image data from the computer, the following message appears:



- ② The printer starts printing after completion of image data transfer. The following message appears.

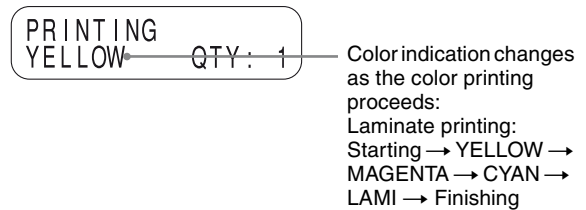

- ③ Depending on the size of image, it takes about 90 seconds (A4+ size paper) for a printout to emerge from the paper outlet. Once printing has been completed, the printer returns to standby status.



Notes

- Do not pull the paper out till the printer finishes printing.
- To prevent paper jamming, **do not allow more than 20 printouts on the paper cover.**

To make a second copy of a printout

Press the PRINT button of the printer. The image data stored in the memory is printed again.

If the printer does not print

The printer will fail to print in the following cases:

- An error message is displayed in the printer window display. Take remedies according to “Error Messages” on page 19.
- The image data stored in the memory is lost when you turn off the power. Even if you press the PRINT button, any image data will not be printed. Send the image data from the computer again.

Notes on storing your printouts

- Avoid storing the printout in a location subject to high temperatures, high humidity, excessive dust and direct sunlight.
- Do not stick tape on a printout. Also avoid leaving a plastic eraser on a printout or placing a printout in contact with materials which contain plasticizer (under a desk mat, for example).
- Do not allow alcohol or other volatile organic solvents to come into contact with the printouts.

Setting the Print Quantity

You can set a print quantity value up to 20 before printing.

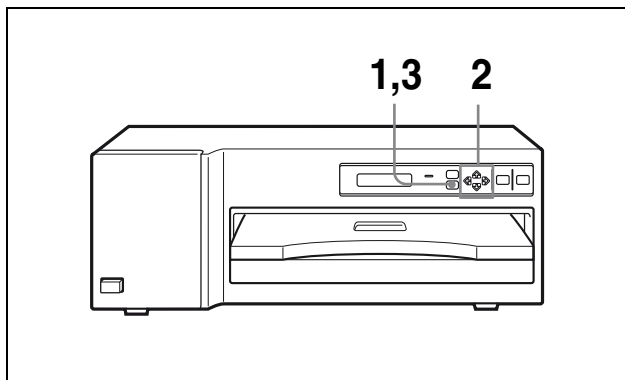

- 1 Press the PRINT QTY button.
The print quantity setting menu is displayed in the printer window display.

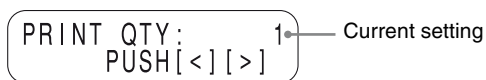

- 2 Set the quantity with the ⇐ or ⇒ button.
⇐ : The number increases.
⇒ : The number decreases.
When you keep the button pressed, the number changes quickly.

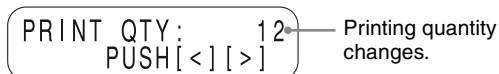

- 3 To exit from the print quantity setting menu, press the PRINT QTY button again.
The printer window display returns to standby status and you can print the number of copies of the renewed setting.



When the paper runs out during printing

Load the paper in the paper tray and press the PRINT button. The printer prints the remaining copies.

Notes

- When you turn off the power, the print quantity setting is reset to 1.
- You can also set the print quantity from the supplied printer driver installed in the computer connected to the printer. By executing printing from the computer, the print quantity value set on the printer is updated by the one set from the printer driver.
- The “QTY” value in the printer window display decreases each time one printout comes out to indicate the remaining copies to be printed.

Adjusting the Printouts

You can adjust the picture quality of a printout with the MENU button before printing. The most recent setting remains effective until changed.

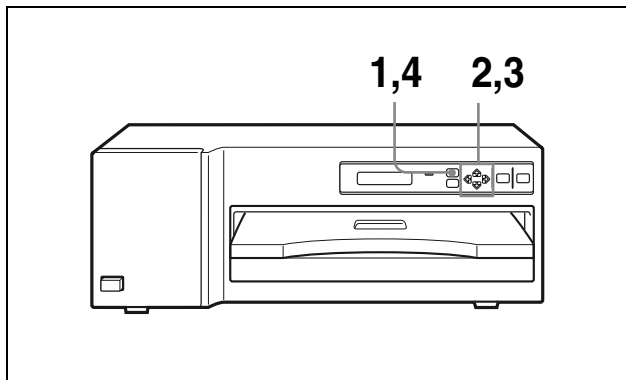

- 1 Press the MENU button.
The COLOR ADJUST menu appears.
- 2 Display the first item of the printout adjust menu (for RED) in the printer window display by pressing the ↕ button.
The default or preset level is shown as a value.

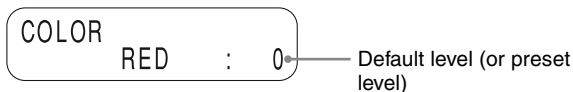

- 3 Perform adjustment.
 - ① Select the item for adjustment by using the ↕ or ↗ button.
 - ↕ : Scrolls up to the next item.
 - ↗ : Scrolls down to the previous item.
 - ② Adjust the level by pressing the ⇐ or ⇒ button. You can adjust the level for RED, GREEN and BLUE of the color, DARK and LIGHT of the tone and GAMMA of the half tone between -32 to +32. The value 0 is the standard level.
 - ⇒ : Increases the level.
 - ⇐ : Decreases the level.
 The sharpness can be adjusted between 0 to 3. 1 is the standard value.
 The LAMINATION can be adjusted among 3 kinds of the lamination types: Glossy/Texture/Matte.

Adjustment items		Adjustment content
COLOR	RED	Red becomes stronger. ^{a)}
	GREEN	Green becomes stronger. ^{a)}
	BLUE	Blue becomes stronger. ^{a)}
BRIGHTNESS	DARK	Dark tone becomes stronger. ^{a)}
	LIGHT	Light tone becomes stronger. ^{a)}
SHARPNESS		The outlines become sharper.
CONTRAST	GAMMA	Half tone colors become stronger. ^{a)}
LAMINATE	Glossy	Glossy surface
	Texture	Silk pattern surface
	Matte	Foggy pattern surface

a) When you press

Example: To set the level of DARK to 12
Press the button Twelfth.

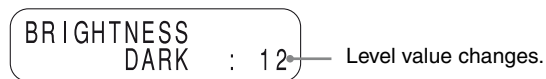

- 4 To exit from the printout adjust menu, press the MENU button again.
The printer returns to standby status.



Notes

- You can also adjust the printout picture quality from the supplied printer driver installed in the computer connected to the printer. By executing printing from the computer, the values set on the printer is updated by ones set from the printer driver.
- The next printout is printed with the newly set values. You cannot adjust the color during printing.

Adjusting the Gray Balance

The ink ribbon and the paper are contained in one same package as a pair. The gray balance may differ depending on each pair. It is recommended that you adjust the gray balance each time you reload the ink ribbon and paper.

The gray balance was set to No.0 at the factory. The setting of the gray balance remains effective until reset - even if you turn the power off.

Before adjusting the gray balance

Perform the following:

- Set the adjusted values for printouts, except SHARPNESS and LAMINATION, to zero (0). (See page 13.)
If the printout adjustment was performed at the computer site, then also set them to 0.
- Set the gray balance to pattern No.0, if you adjusted the gray balance previously. (See explanation described below.)

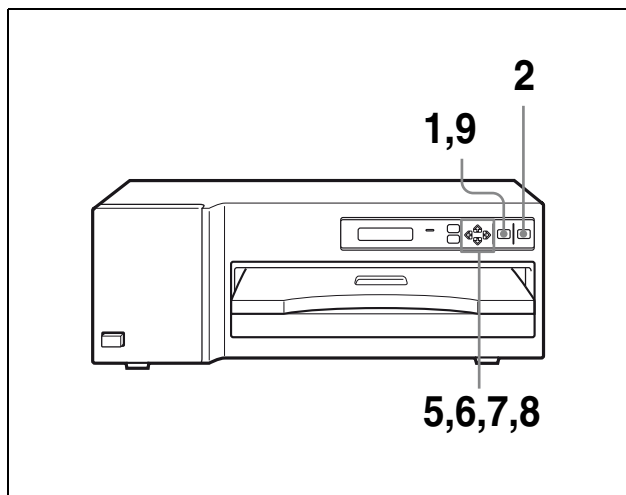

- 1 Press the CAL button.
GRAY PATCH PRINT appears.

```
GRAY PATCH PRINT [A+B]
[PRINT]
```

Press the CAL button to display GRAY PATCH PRINT.

- 2 Press the PRINT button.
Gray patterns Group A and Group B are printed.
- 3 Look at the printout of Group A to determine the best gray balance from this group.

- 4 Next, look at the printout of Group B to determine the best gray balance from this group, too.
- 5 Press the \uparrow and \downarrow buttons to select GRAY ADJUST [A].
The printer enters the gray balance adjustment mode.

```
GRAY ADJUST [A]
< 0 > [0-88]
```

Press \uparrow and \downarrow to display GRAY ADJUST [A].

- 6 Press the \leftarrow and \rightarrow buttons to display the pattern number determined in step 3.
For example, select 18 if you determined that pattern No. 18 in the sample provides the best color tone of the gray balance.

```
GRAY ADJUST [A]
<18> [0-88]
```

Press \leftarrow and \rightarrow to display 18.

- 7 Press the \uparrow and \downarrow buttons to select GRAY ADJUST [B].
The printer enters the adjustment mode of the color tone of the gray balance.

```
GRAY ADJUST [B]
< 0 > [0-88]
```

Press \uparrow and \downarrow to display GRAY ADJUST [B].

- 8 Press the \leftarrow and \rightarrow buttons to display the pattern number determined in step 5.
For example, select 39 if you determined that pattern No. 39 in the sample provides the best gray balance.

```
GRAY ADJUST [B]
<39> [0-88]
```

Press \leftarrow and \rightarrow to display 39.

- 9 Press the CAL button.
The printer returns to the on-line mode.

Precautions

Safety

- Operate the printer using the power source specified in “Specifications” (page 18).
- Be careful not to damage the power cable by placing or dropping heavy objects on it; it is dangerous to use the unit with a damaged power cable.
- If you do not intend to use the unit for a long time, disconnect the power cable.
- Unplug the power cable by grasping the plug, not the cable itself.
- Do not disassemble the unit. There is a danger of electric shock from the internal parts.
- Be careful not to spill water or other liquids on the unit, or to allow combustible or metallic material to enter the cabinet. If used with foreign matter in the cabinet, the unit is liable to fail, or present a risk of fire or electric shock.
- If the unit malfunctions or if a foreign body falls into the cabinet, disconnect the power immediately and consult your Sony service facility or your Sony dealer.

Installation

- Avoid placing the unit in a location subject to:
 - mechanical vibration
 - high humidity
 - excessive dust
 - direct or excessive sunlight
 - extremely high or low temperatures
- Ventilation holes are provided on the back of the unit to prevent the unit from overheating. Be careful not to obstruct them with other objects or by covering the unit with a cloth etc.

On condensation

- If the printer is subjected to wide and sudden changes in temperature, such as when it is moved from a cold room to a warm room or when it is left in a room with a heater that tends to produce quantities of moisture, condensation may form inside the printer. In such cases the printer will probably not work properly, and may even develop a fault if you persist in using it. If moisture condensation forms, turn off the power and leave the printer standing for at least one hour.
- If the printing pack is subjected to wide and sudden changes in temperature, condensation may form on the ink ribbon or paper inside. This will cause the

printer to malfunction. Also if the printing pack is used in this state, spots are likely to appear on the printout.

- To store a half-used printing pack, replace it in its original packing and reseal the package. If possible, keep the sealed printing pack in a cool, dark location. To subsequently use the printing pack, place it, in its sealed package, in a warm room for several hours. Doing so prevents condensation from forming when the printing pack is removed from its package.

On Transportation

Do not transport the printer with the supplied accessories. Doing so may cause malfunction.

- 1 Remove the ink ribbon cassette and the paper tray.
- 2 Lock the thermal head.
 - ① Turn on the power of the printer.
 - ② Press the CAL, ⇐ and ⇒ buttons together.
 - ③ Turn off the power of the printer.

Note

Never put your hand into the ink ribbon compartment, when locking the thermal head. Doing so may cause injury to your hand because it may be caught by the thermal head.

To unlock the thermal head

Turn on the power of the printer again. The thermal head moves and you can load the ink ribbon cassette again.

Cleaning

Note

Be sure to turn off the power of the printer before cleaning it. The ink ribbon and paper roll removed

When the cabinet becomes dirty

Clean the cabinet, panel and controls with a soft dry cloth, or a soft cloth lightly moistened with a mild detergent solution.

Do not use any type of solvent, such as alcohol or benzene or chemical cloth, which may damage the finish.

Cleaning the filter

Ventilation holes are provided to prevent the unit from overheating on the left side and the rear of the printer. When the message “CLEAN FAN FILTER” appears on the printer window display, the filter of the ventilation holes on the left side has become dirty. To clean the filter, proceed as follows.

- 1 Remove the fan cover, then filter.

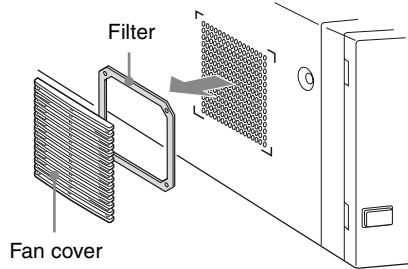

- 2 Clean the fan using the vacuum cleaner and the like.

Notes

- Be careful that the filter will be caught in the cleaner.
- Do not rub the net of the fan strongly.

- 3 Reset the filter and the fan cover on the side panel as they were.

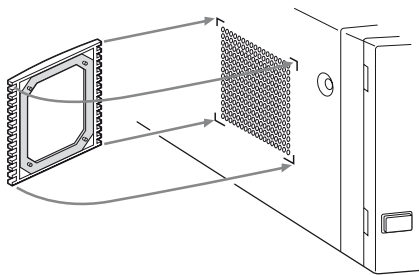

Cleaning the thermal head

You should clean the thermal head in the following cases:

- When the vertical white stripe appears on the printout.
- When the scratch appears on the printout.

How to use the white tip and black tip

When using the white tip, the sponge roller wipes off the dust on the thermal head.

When using the black tip, the polishing material on the sponge roller scrapes off the dust on the head.

Use the white tip in the following cases

- When a vertical white stripe appears on the printout because of dirt on the thermal head.
- Ordinary head cleaning for preventing accumulation of dirt on the head

Use the black tip in the following cases

- When a scratch appears only on the printout, but no scratches appear on the spaces around the picture.

- When the use of the white tip has no effect.
- Periodic head cleaning

We recommend use of the black tip every month (or every 500 sheets of printout) to keep the thermal head clean.

Store the tips by inserting the white one into the cleaning tip hole on the holder, and the black one into the spare tip hole.

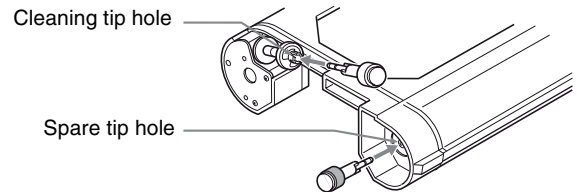

Attaching the tips on the cleaning kit holder

- 1 Align the pronged parts of the tip with the cross notches of the hole.

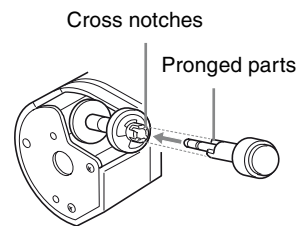

- 2 Insert the tip fully until it stops with a click.

Turning the tip to keep the cleaning effect

The cleaning effects decreases when the tip is used the following number of times:

White tip: Cleaning about 30 times

Black tip: Cleaning one time

To regain the original cleaning effect, reinsert the tip, as shown below, so that you can clean the head with the unused surface of the tip.

Pull out the tip, turn it 90°, then reinsert it.

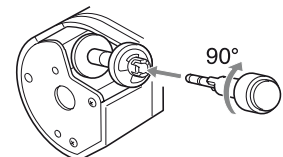

One tip provides four new surfaces. After using all unused surfaces, exchange the tip for a new one. The cleaning tip set is available using part number A-8279-104 (at a charge).

Cleaning of the thermal head

To clean the thermal head, proceed as follows:

- 1 Remove the ink ribbon cassette from the printer.
- 2 Attach the cleaning tip to the cleaning tip holder, and install the cleaning tip holder in the printer. The cleaning tip holder can be mounted in the same way as that of the ink ribbon cassette.
- 3 Insert the cleaning tip holder fully until it stops, then pull the holder out until the open window of the holder fully appears. **Repeat the inserting/pulling-out of the holder about three times.**

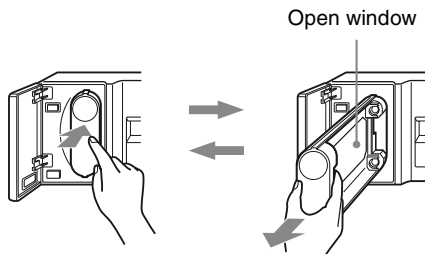

Thermal head cleaning is finished.

- 4 Remove the cleaning tip holder from the printer, and remount the ink ribbon cassette in the printer.

Notes

- Don't moisten the tip with the cleaning liquid or water. A moistened tip may deteriorate the performance of the thermal head.
- Especially when using the black tip, be careful not to insert/pull-out the holder too many times at one cleaning. The lifespan of the head may be decreased.
- Be careful not to swallow the cleaning tips. Store them out of the reach of children.

Ink Ribbon and paper

You need paper and ink ribbon cassette for printing. ("Ink ribbon cassette" stands for the supplied ink ribbon holder loaded with ink ribbon.) Use the ink ribbon and paper contained in the same package. If the printer detects an incompatible combination, an error message appears in the printer window display and you cannot make printouts.

Self-laminating Color Printing Pack UPC-740 (for the customers in the European countries) Self-laminating Color Printing Pack UPC-741 (for the customers in the U.S.A. and Canada)

Contains an ink ribbon and paper for automatic laminate coating.

Color ink ribbon 1 roll

Letter size paper 72 sheets

Self-laminating Color Printing Pack UPC-747

Contains an ink ribbon and paper for automatic laminate coating.

Color ink ribbon 1 roll

A4+ size paper 72 sheets (The size is little larger than A4 size paper. This paper allows you to make the printout of the A4 size.)

Notes

- Use only ink ribbon and paper for this printer. If you use a different type, the printer may not print properly or malfunction.
- Ink ribbon and paper are not reusable. After you finish with them, replace them with new ones.

Specifications

Power requirements	100 – 240 V AC, 50/60Hz
Input current	3.0 – 1.3 A
Operating temperatures	5°C to 35°C
Dimensions	Approx. 493.8 × 176 × 468.8 mm (w/h/d) (19 ½ × 7 × 18 ½ inches)
Mass	Approx. 18 kg. (39 lb 11 Oz)
Printing system	Dye transfer sublimation thermal printing
Thermal head	2,560 elements, 11.8 dot/mm (300dpi)
Gradations	8 bits (256 levels) processing each for yellow, magenta and cyan
Print size	Maximum Letter size: 254.0 × 203.2 mm (w/h) (10 × 8 inches) A4 size: 271.6 × 203.2 mm (w/h) (10 ¾ × 8 inches) A4+ size: 297.0 × 215.9 mm (w/h) (11 ¾ × 8 ½ inches)
Picture elements	Maximum Letter size: 3,000 × 2,400 dots (w/h) A4 size: 3,208 × 2,400 dots (w/h) A4+ size: 3,508 × 2,560 dots (w/h) (5 dots each of upper and lower sides are not printed for the A4+ size.)
Printing time	Approx. 80 seconds per page (letter size) Approx. 85 seconds per page (A4 size) Approx. 90 seconds per page (A4+ size)
Interface	Hi-Speed USB (USB 2.0)
Accessories supplied	Ink ribbon holder (1) Paper tray (1) Paper cover (1) Fan cover (1) Bottom cover (1) Ferrite core (1) Thermal Head Cleaning Kit (1) AC power cord (1) Operating Instructions (1) Warranty Card (1) CD-ROM (1) SOFTWARE LICENSE AGREEMENT (1)
Optional accessories	Self-laminating Color Printing Pack UPC-740 (for the customers in the European countries)

Self-laminating Color Printing Pack
UPC-741 (for the customers in the U.S.A. and Canada)
Self-laminating Color Printing Pack
UPC-747

Design and specifications are subject to change without notice.

Troubleshooting

If a problem appears, check the following trouble shooting guide first and perform whatever action is necessary to solve the problem. If the problem persists, turn off the printer and consult with your Sony dealer.

Symptom	Possible causes and remedies
Nothing appears in the printer window display.	The POWER switch of the printer is not set to ON. →Set the POWER switch of the printer to ON. If the POWER switch is set to ON, once set it to OFF, then to ON again. (page 4)
	Connections may not be correct. →Make connections correctly. (page 7)
The printer does not print.	An error message appears on the printer window display. →Take remedies according to “Error Messages.”(page 19).
	An ink ribbon cassette and paper are not loaded. →Load an ink ribbon cassette and paper. (pages 8 and 9)

Error Messages

If a problem occurs, the ALARM indicator lights and an error message stating the problem appears in the printer window display. Note the message and perform whatever action is necessary to solve the problem.

Error messages	Possible causes and remedies
END OF RIBBON	The ink ribbon has been completely used. →Replace with the new ink ribbon. (Ink ribbons cannot be reused.) (page 8)
HEAD IN COOLING	The thermal head has overheated. →Leave the printer until the head cools down and this message disappears.
HEAD IN HEATING	The thermal head is warming up. →Leave the printer until the head has warmed up and this message disappears.
NO RIBBON	Ink ribbon cassette is not fitted properly. →Ensure that the ink ribbon is loaded properly in the ink ribbon holder, and the ink ribbon cassette in the printer. (page 8)
NO IMAGE DATA	No image data is stored in the printer memory. →Transfer the image data from your computer. (page 11)
NO PAPER	The paper has run out. →Load the paper into the paper tray. (page 9)

Error messages	Possible causes and remedies
PLEASE WAIT	When you turn off the power while printing, or the printer detects an invalid combination of the paper and ink ribbon and automatically stops printing, this message appears. →Wait for the printer to eject the paper.
REMOVE PAPER AND PRESS [⇨]	The paper has jammed. →Remove jammed paper from the printer and press ⇨ button. (page 19)
RIBBON ERROR	The ink ribbon develops some trouble. →Ensure that the ink ribbon does not tear and the ink ribbon cassette and paper tray are loaded properly. (page 9)
MECHA TROUBLE	The mechanical trouble occurs in the printer. →Turn off the power once and then turn it on. If the message will still remain in the printer window display, turn off the power immediately and contact your Sony dealer.

If the Paper Jams

If the paper jams, printing stops and the error message stating “CHECK PAPER AND PRESS [⇨]” or “REMOVE PAPER AND PRESS [⇨]” appears on the printer window display. Follow the steps below to remove the jammed paper.

- 1 Remove the paper cover.
If any printouts have been ejected on the paper cover, remove them first before removing the paper cover.

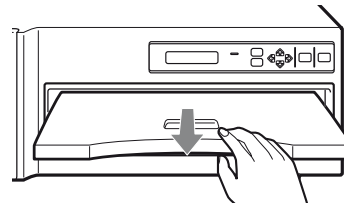

- 2 Check where any paper is jammed inside the printer.
If you find a jammed sheet around the paper outlet, slowly pull it out straightly to the right.

If you find a jammed sheet on the way inside the printer, slowly pull it out to the right. If the tray cover is in the way, remove it.

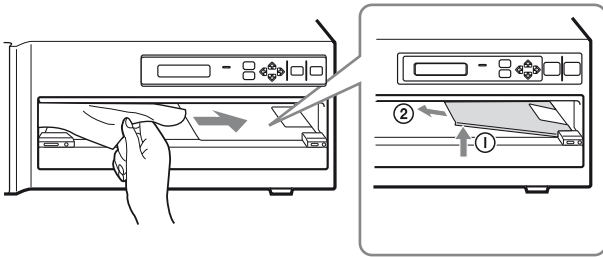

If the tray cover is in the way, remove it by lifting it up ①, and then pulling it out to the direction of arrow ②.

- 3** Press PUSH on the paper tray.
The paper tray pops out.

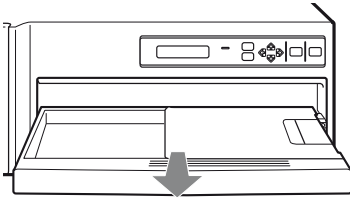

- 4** Remove the bottom cover.

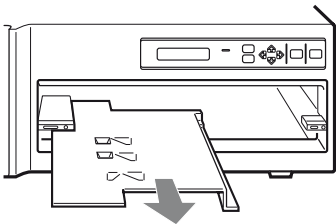

- 5** Check whether any paper is found on the bottom of the printer. If you find one, remove it.

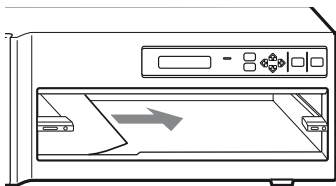

- 6** Ensure that the paper is properly loaded.
Discard the sheets removed in steps 2 and 5

- 7** Re-insert the removed bottom cover, paper tray, tray cover and/or paper cover into the printer.

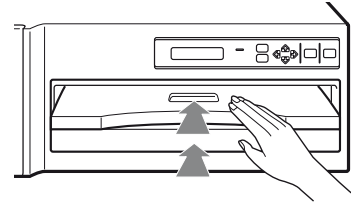

- 8** Press the button.
The error message disappears and the printer returns to the standby status.

READY
A4+ QTY: 1

Index

A

AC power cord 6
Accessories supplied 6, 18
Adjusting the gray balance 14
Adjusting the printouts 13
 BRIGHTNESS 13
 COLOR 13
 CONTRAST 13
 LAMINATE 13
 SHARPNESS 13
Assembly 6

B

Bar codes 9
BLUE 13
Bottom cover 6, 20
BRIGHTNESS 13

C

Cable stopper
 securing USB cable 7
CAL button 14
Cleaning
 Cabinet 15
 Filter 15
 Thermal head 16
COLOR 13
Color printing pack 17
Combination of ink ribbon and paper 17
Connections 7
 AC power cord 7
 USB port 7
CONTRAST 13

D

DARK 13

E

EJECT button 8
Error messages 19

F

Fan 6, 16
Features 4
Ferrite core 7
Filter 6, 16

G

GAMMA 13
Gray balance 14
GREEN 13

I

Image data 11
Ink ribbon 8
Ink ribbon and paper
 usable printing pack 17
Ink ribbon cassette
 Bar codes 9
 If your ink ribbon should tear 9
 Loading 8
 Notes on storing 9
 Removing any slack 9
 Start position marker 9
Ink ribbon holder 6, 8
Introduction 4

L

LAMINATE 13
 printing pack 17
LIGHT 13
Loading the paper 9

M

MENU button 13
Mounting paper tray and cover 6

P

Paper
 adding paper 10
 If paper jams 19
 Loading 9
Paper cover 6
Paper jams 19
Paper outlet 11
Paper tray 6, 9, 10
Part Names and Functions
 Front 4
 Rear 5
Power requirements 18
Precautions
 Condensation 15
 Installation 15
 Safety 15
 Transportation 15
PRINT button 11, 12, 14
Print paper
 Notes on storing 10
 When the print paper runs out
 during printing 12
PRINT QTY button 12

Print quantity 12
Print size 18
Printer driver
 Installing 7
Printer window display 11
Printing 11
 If the printer does not print 11
 To make a second copy 11
Printing pack 17
Printing time 18
Printouts 11
 Adjusting 13
 Notes on storing 11

R

RED 13
Ribbon and paper 17
Ribbon door 8

S

Setting the print quantity 12
SHARPNESS 13
Specifications 18
Standby status 11
Start position marker 9
Supplied accessories 6
 AC power cord 6
 Bottom cover 6
 CD-ROM 6
 Fan cover 6
 Ink ribbon holder 6
 Paper cover 6
 Paper tray 6
System configuration 4

T

Troubleshooting 19

U

USB cable 7
USB port connection 7

Free Manuals Download Website

<http://myh66.com>

<http://usermanuals.us>

<http://www.somanuals.com>

<http://www.4manuals.cc>

<http://www.manual-lib.com>

<http://www.404manual.com>

<http://www.luxmanual.com>

<http://aubethermostatmanual.com>

Golf course search by state

<http://golfingnear.com>

Email search by domain

<http://emailbydomain.com>

Auto manuals search

<http://auto.somanuals.com>

TV manuals search

<http://tv.somanuals.com>