● ● ● ● ●

REFERENCE

414s

644s

4/3/2 Channel
Power Amplifiers

OWNER'S MANUAL
AND
INSTALLATION GUIDE

SOUNDSTREAM[®]

T E C H N O L O G I E S

● ● ● ● ●

CONGRATULATIONS!

You now own a REFERENCE Amplifier, the product of an uncompromising design and engineering philosophy. Your Soundstream REFERENCE amplifier will outperform any other amplifier in the world.

To maximize the performance of your system, we recommend that you thoroughly acquaint yourself with its capabilities and features. Please retain this manual and your sales and installation receipts for future reference.

Soundstream amplifiers are the result of American craftsmanship and the highest quality control standards, and when properly installed, will provide you with many years of listening pleasure. Should your amplifier ever need service or replacement due to theft, please record the following information. which will help protect your investment.

Model and Serial # _____

Dealer's Name _____

Date of Purchase _____

Installation Shop _____

Installation Date _____

CAUTION!

Prolonged listening at high levels may result in hearing loss. Even though your new Soundstream REFERENCE amplifier sounds better than anything you've ever heard, exercise caution to prevent hearing damage.

● ● ● ● ●

TABLE OF CONTENTS

Design Features	4	-	5
Reference41 4s Diagram	6	-	7
Reference644s Diagram.....	8	-	9
High Power/Auto High Current™ Power Supply Design.....	10		
Selecting Input Modes..	11		
Balanced / Unbalanced Input (Reference644s)	12		
Wiring & Wiring Diagram	13	-	14
Installation and Mounting	15		
Level Setting (Reference414s)	16		
Level Setting (Reference644s)	17		
Crossover Adjustments	18		
AIRBASS™	19		
Sample Systems	20	-	25
Troubleshooting.....	26		
Service	26		
Protection Circuitry.....	27		
Specifications	27		

DESIGN FEATURES

- Uncompromising Design and Construction including mil-spec glass epoxy circuit boards and high current custom gold-plated solid brass connections that will accept up to 4 gauge power/ground wire.
- Auto **High Current™** - Soundstream's exclusive circuit which automatically customizes your amplifier to its particular application-High Current, low impedance loads (multiple subwoofers. less than 2 ohms mono) or High Power, higher impedance loads (2 ohms mono and up).
- Coherent **Stereo™/Mixed Mono** selection for either "pure" stereo operation or mixed mono for simultaneous stereo and mono.
- **Chassisink™** Darlington Power Array Soundstream's "overbuilding" of the output section incorporates multiple output transistors instead of a few for faster, stronger power delivery. The transistors are sandwiched between the circuit board and the heatsink in a design called Chassisink™ to ensure cool, efficient amplifier operation.
- **PowerGrid™** Power Supply Design - All power supply components are located near one another, connected by thick, wide PCB traces, which ensures rapid, high current delivery The entire power supply is isolated on one side of the circuit board while the audio stage is located opposite it, guaranteeing minimal noise.
- Ultra-Low ESR Capacitance Bank Multiple small input power capacitors are used to provide lower ESR (Equivalent Series Resistance), which means more *power in* and out *faster*.
- Smart Thermal **Rollback™** - Most amplifiers shut off when they get too hot. In the unlikely event the REFERENCE amplifier reaches 85" C, it will gradually roll back its average power (without affecting the dynamics). Once the amplifier has cooled off, it returns to full power output. If overheating should continue, a second thermal sensing protection circuit will shut off the amplifier if the heatsink reaches 95" C.
- Fault Monitor LED on the top panel notifies you of blown power supply fuses.

- **1/2 ohm Drive Ability - (Reference644s only)** The REFERENCE6445 amplifier is designed to drive virtually any load-all the way down to 1/2 ohm stereo (1 ohm mono).
- **1 ohm Drive Ability - (Reference414s only)** The REFERENCE414s amplifier is designed to drive virtually any load--all the way down to 1 ohm stereo (2 ohm mono).
- Dual Discrete Class A Drive Stages - Over 12 times the drive current of most amplifiers, which maintains performance into low impedance loads.
- Drive Delay™ Muted Turn-on/off Circuit - A unique circuit which completely eliminates any amplifier-related turn-on/off noises.
- Flexible Dual Input Level Sensitivity (Reference644s only) accepts 2 voltage ranges; from 200 mV to 2.0 V and from 500 mV to 5.0 V. permitting maximum output from the amplifier with virtually any source unit. The Reference414s has a single input range, varying from 200 mV to 5.0 V.
- Differential Balanced Input Design for added immunity to noise caused by component and vehicle electrical system interaction when using unbalanced RCA inputs.
- True Balanced Input (Reference644s only) for professional-quality performance and noise cancellation. The 6-pin DIN plug carries (+) and (-) signal information for left and right channels, audio ground, and ±15 Vdc to operate the Soundstream **BLT™** or **BLT4™** Balanced Line Transmitters.
- **AIRBASS™** Upgradable - This feature allows RF remote control level adjustment while the low pass filter on the amplifier's internal crossover is being used.

Reference414s

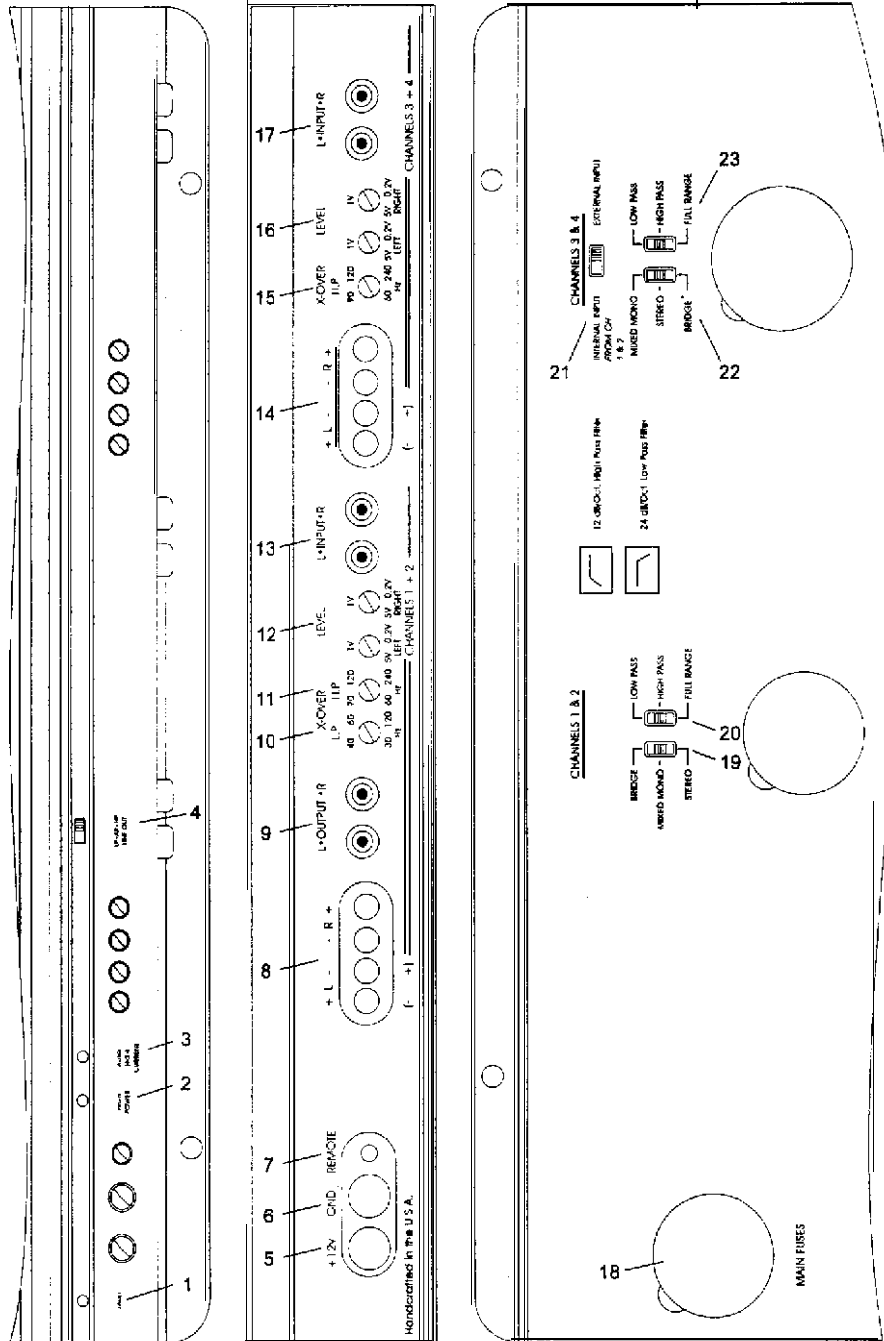

TOP VIEW (PARTIAL)

FRONT VIEW

BOTTOM VIEW (PARTIAL)

1. **Fault LED** - Indicates a blown fuse.
2. **High Power LED** - Indicates amplifier power on in "High Power" mode.
3. **Auto High Current™ LED** - Indicates amplifier power on in "High Current" mode.
4. **Line Out Crossover Switch** - Select high pass, low pass or full range low level output to an auxiliary amplifier.
5. **+12V** - Connected to a fuse or circuit breaker, then to the battery's positive post.
6. **GND** - Main ground connection. Bolt to a clean chassis ground in the vehicle.
7. **REM** - Remote turn-on input from the head unit. Accepts +12V.
8. **Speaker Output Connections** - Channels 1 & 2 speaker connection terminal.
9. **Crossover Output** - High pass, low pass or full range output to an auxiliary amplifier.
10. **Low Pass Crossover Adjustment Pot** - Crossover frequency setting for the low pass filter; Amplifier channels 1 - 4 and crossover outputs.
11. **High Pass Crossover Adjustment Pot** - Crossover frequency setting for the high pass filter for channels 1 & 2 and crossover outputs.
12. **Input Level** - Channels 1 & 2; Independent left and right channel input level controls.
13. **Inputs** - Channels 1 & 2; right and left RCA inputs.
14. **Speaker Output Connections** - Channels 3 & 4 speaker connection terminal.
15. **High Pass Crossover Adjustment Pot** - Crossover frequency setting for the high pass filter for channels 3 & 4.
16. **Input Level** - Channels 3 & 4; Independent left and right channel input level controls.
17. **Inputs** - Channels 3 & 4; right and left RCA inputs.
18. **Main Fuse** - Main power supply fuses. Replace only with the same value fuses.
19. **Coherent Stereo™/Bridge/Mixed Mono switch** - Channels 1 & 2; Input mode selector.
20. **Amplifier Crossover** - Channels 1 & 2; Select high pass, low pass or full range operation.
21. **Channels 3 & 4 Input Select** - Selectable inputs from internal (from channels 1 & 2) or external (from channels 3 & 4 local inputs).
22. **Coherent Stereo™/Bridge/Mixed Mono switch** - Channels 3 & 4; Input mode selector.
23. **Amplifier Crossover** - Channels 3 & 4; Select high pass, low pass or full range operation.

Reference644s

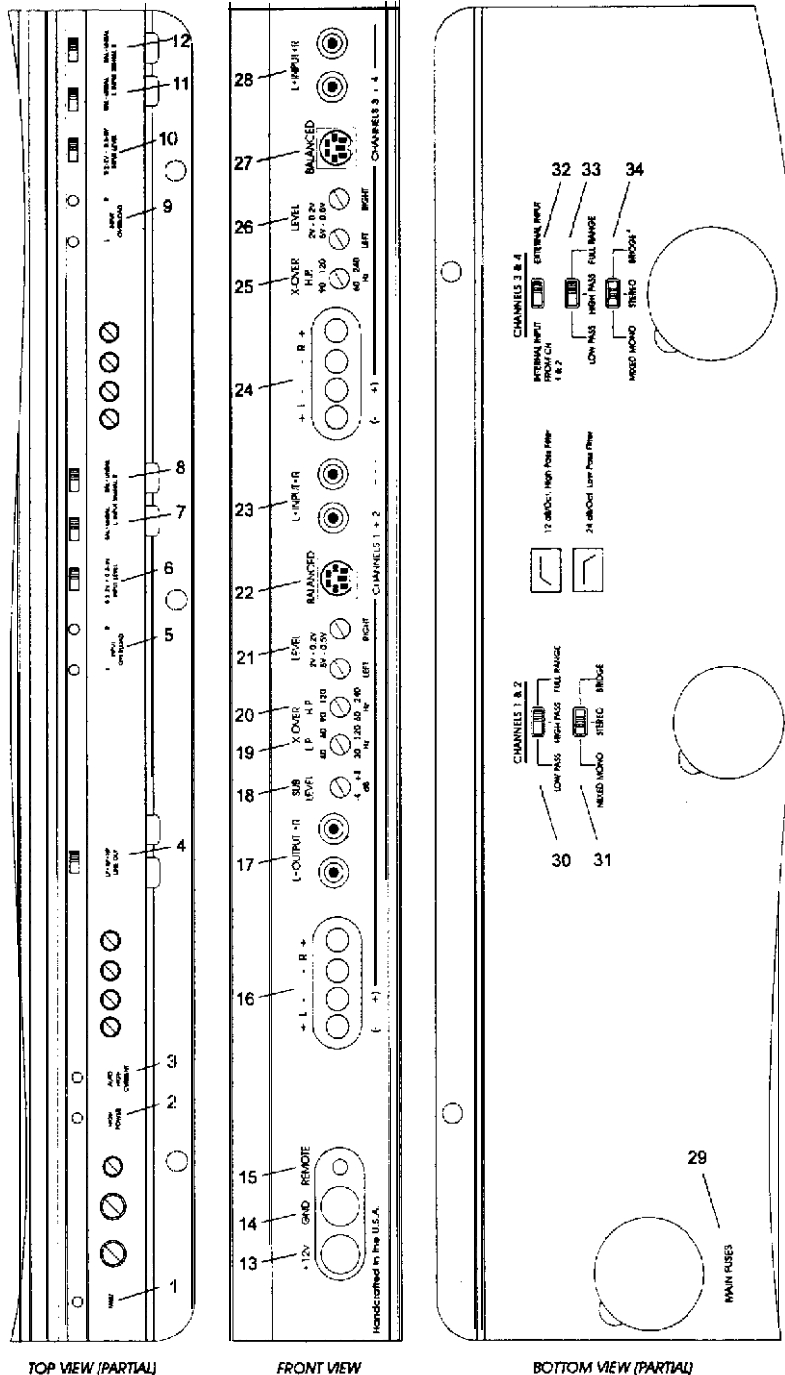

1. **Fault LED** - Indicates a blown fuse.
2. **High Power LED** - Indicates amplifier power on in "High Power" mode.
3. **Auto High Current™ LED** - Indicates amplifier power on in "High Current" mode.
4. **Line Out Crossover Switch** - Select high pass, low pass or full range low level output to an auxiliary amplifier.
5. **Input Overload Indicators** - Channels 1 & 2; Indicates the signal input level or input gain level is too high.
6. **Input Level Selector Switch** - Channels 1 & 2; Selectable input sensitivity range from 0.2-2 Volts RMS, or from 0.5-5 Volts RMS.
7. **Left Channel Balanced / Unbalanced Input Selector Switch** - Channel 1; Select "Balanced" to use the 6-pin balanced signal input. Select "Unbalanced" to use the RCA signal inputs.
8. **Right Channel Balanced / Unbalanced Input Selector Switch** - Channel 2; Select "Balanced" to use the 6-pin balanced signal input. Select "Unbalanced" to use the RCA signal inputs.
9. **Input Overload Indicators** - Channels 3 & 4; Indicates the signal input level or input gain level is too high.
10. **Input Level Selector Switch** - Channels 3 & 4; Selectable input sensitivity range from 0.2-2 Volts RMS, or from 0.5-5 Volts RMS.
11. **Left Channel Balanced / Unbalanced Input Selector Switch** - Channel 3; Select "Balanced" to use the 6-pin balanced signal input. Select "Unbalanced" to use the RCA signal inputs.
12. **Right Channel Balanced / Unbalanced Input Selector Switch** - Channel 4; Select "Balanced" to use the 6-pin balanced signal input. Select "Unbalanced" to use the RCA signal inputs.
13. **+12V** - Connected to a fuse or circuit breaker, then to the battery's positive post.
14. **GND** - Main ground connection. Bolt to a clean chassis ground in the vehicle.
15. **REM** - Remote turn-on input from the head unit. Accepts +12V.
16. **Speaker Output Connections** - Channels 1 & 2 speaker connection terminal.
17. **Crossover Output** - High pass, low pass or full range output to an auxiliary amplifier.
18. **Subwoofer Level Control** - Additional level control to any channel or line output receiving information from the internal low pass filter.
19. **Low Pass Crossover Adjustment Pot** - Crossover frequency setting for the low pass filter; Amplifier channels 1 - 4 and crossover outputs.
20. **High Pass Crossover Adjustment Pot** - Crossover frequency setting for the high pass filter for channels 1 & 2 and crossover outputs.
21. **Input Level** - Channels 1 & 2; Independent left and right channel input level controls.
22. **Balanced Signal Input Connector** - Channels 1 & 2; 6-pin balanced signal input connector for use with the Soundstream BLT™ or BLT4™ Balanced Line Transmitters.
23. **Inputs** - Channels 1 & 2; right and left RCA (Unbalanced) inputs.
24. **Speaker Output Connections** - Channels 3 & 4 speaker connection terminal.
25. **High Pass Crossover Adjustment Pot** - Crossover frequency setting for the high pass filter for channels 3 & 4.
26. **Input Level** - Channels 3 & 4; Independent left and right channel input level controls.
27. **Balanced Signal Input Connector** - Channels 3 & 4; 6-pin Balanced signal input connector for use with the Soundstream BLT™ or BLT4™ Balanced Line Transmitter.
28. **Inputs** - Channels 3 & 4; right and left RCA (Unbalanced) inputs.
29. **Main Fuse** - Main power supply fuses. Replace only with the same value fuses.
30. **Amplifier Crossover** - Channels 1 & 2; Select high pass, low pass or full range operation.
31. **Coherent Stereo™/Bridge/Mixed Mono switch** - Channels 1 & 2; Input mode selector.
32. **Channels 3 & 4 Input Select** - Selectable inputs from internal (from channels 1 & 2) or external (from channels 3 & 4 local balanced or unbalanced inputs).
33. **Amplifier Crossover** - Channels 3 & 4; Select high pass, low pass or full range operation.
34. **Coherent Stereo™/Bridge/Mixed Mono switch** - Channels 3 & 4; Input mode selector.

INSTALLATION STEP 1

COHERENT STEREO™ / MIXED-MONO / BRIDGED MONO

The REFERENCE amplifier has the ability to operate in any one of the following modes:

Coherent Stereo™ with identical left and right stereo channels for maximum fidelity. Best choice for satellite speakers. Use this mode unless Mixed-Mono is necessary.

Mixed-Mono in order to drive stereo and mono simultaneously; works well for center channels. It can be used anytime you need a summed mono channel. Somewhat sacrifices sonic accuracy as additional circuitry is introduced to one channel. In Mixed-Mono, *the left channel is inverted*, see diagram below or on the bottom of the amplifier.

Bridged Mono for dedicated single channel operation; ideal for driving subwoofers. It is also used when large amounts of power are necessary for single speakers. In *bridged mono, only the right channel input is active*.

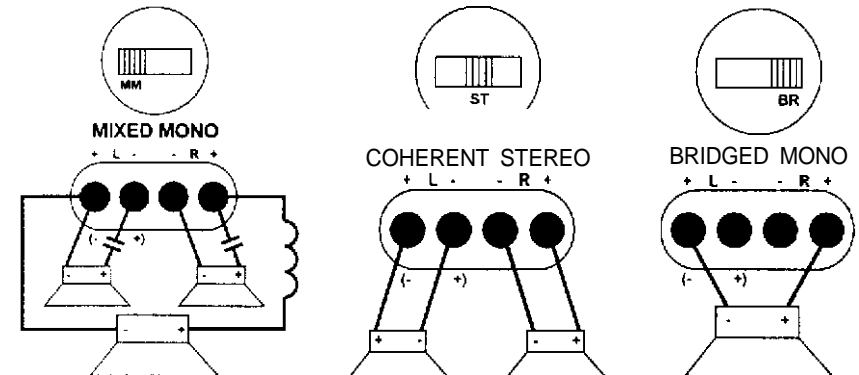

In bridged mono, only the right channel input is active.

OK

NOTE: If you intend to drive a REFERENCE amp in mono but have stereo outputs from your crossover or source unit, you can pot the switch in Mixed-Mono but follow the normal wiring for Bridged Mono.

AUTO HIGH CURRENT™ POWER SUPPLY

The REFERENCE amplifier employs an extremely efficient *Auto High Current™* power supply (patent pending). This power supply circuitry automatically customizes your amplifier for optimum efficiency and power output into virtually any impedance load. When other brand amplifiers are driven at low impedances (i.e., 1 ohm or less), they shut down, squash dynamics and power output (called current limiting). or waste huge amounts of power (i.e., low efficiency). All of which reduce the "real world" power the amplifier can produce in the car. Soundstream's *Auto High Current™* power supply allows the REFERENCE amplifiers to be one of two types of amps: either producing maximum power at higher impedances (perfect for satellites) or at lower impedances (usually with multiple subwoofers). This is done by letting the amplifier's power supply continuously monitor the impedance of the load the amplifier is driving. If the impedance drops too low, the power supply will automatically switch into *High Current* mode. It will stay in this mode until the amplifier is turned off. The next time it is powered up, it will be in the High *Power* mode.

Unlike other amplifiers, Soundstream's REFERENCE amplifiers can be configured to drive virtually any impedance and make maximum power! The major advantages of this power supply are:

- awesome dynamic power capabilities
- added continuous power with higher voltages
- increased amplifier efficiency and reliability

Because of the dynamic properties of most music; all audio components should be able to react accordingly. Thanks to their unique power supplies, the REFERENCE amplifiers can comfortably exceed their rated power for dynamic portions of the music.

I INSTALLATION STEP 2

BALANCED/UNBALANCED INPUT

The REFERENCE6445 amplifier has the ability to accept either standard Unbalanced RCA signal inputs, or Balanced "Pro Audio" inputs with the use of the Soundstream **BLT™** or **BLT4™** Balanced Line Transmitters or some other balanced line audio source. Before installing your system, you should decide upon which signal type you wish to run. There are advantages to both:

	UNBALANCED INPUT	BALANCED INPUT
ADVANTAGES	<ol style="list-style-type: none"> 1. Most preamplifier/ source units have "UNBAL" RCA outputs. (Industry standard) 2. No Interface module is necessary 	<ol style="list-style-type: none"> 1. Improved Signal-to-Noise Ratio. (S/N Ratio) 2. Excellent noise cancellation characteristics. 3. Immune to noise radiated in the car audio environment.

The REFERENCE644s amplifier's signal input? accept two ranges of input signal levels: 0.2 2.0 Vrms, or 0.5 - 5.0 Vrms for both Balanced and Unbalanced inputs. The input range switch position and level settings are dependent upon the preamplifier / source unit output signal level. For the best system Signal-to-Noise Ratio, we recommend that the input level controls be set as far down as possible (rotated counter-clockwise), while maintaining an acceptable level of output.

Using the "Unbalanced" RCA input

When using the Unbalanced RCA input, the *RIGHT* channel (channel 2) input signal switch *MUST* be in the "UNBAL" position. Also, when first installing the amplifier using this input configuration, we suggest that the remaining input signal switches be in the "UNBAL" position as well. If you experience alternator whine or other installation noise with both switches in the "UNBAL" position, try moving channels 1, 3 & 4 input signal switches to the position. This should remove any system noise due to installation.

Using the "Balanced" RCA input

When using the Balanced 6-pin DIN input, both switches *MUST* be in the "BAL" position. Also, we recommend that when using this input configuration, the "INPUT LEVEL" switch be in the "0.5 - 5V" position, and the gains on the amplifiers be set to "minimum" (rotated counter-clockwise). The system gains should then be adjusted on the **BLT™** or **BLT4™** Balanced Line Transmitter, or other balanced line audio source. For the pin configuration, see the diagram below:

NOTE: The pin configuration shown in the diagram is the view looking into the balanced input jack on the amplifier.

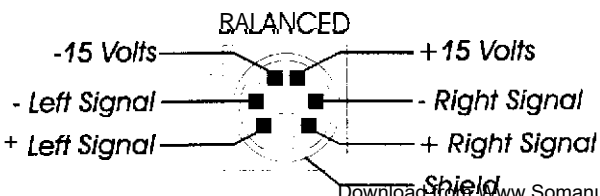

INSTALLATION STEP 3

WIRING

POWER AND GROUND

To ensure maximum output from your REFERENCE amplifiers, use high quality, low-loss power and ground cables. The REFERENCE amplifiers will accept up to 4 gauge power and ground cables. Determine from the chart below the minimum gauge power and ground wire for your application.

	up to 10'	up to 20
REFERENCE414s	Soundstream Power40 or Power80 (4 or 8 ga.)	Soundstream Power40 (4 ga.)
REFERENCE644s	Soundstream Power40 or Power80 (4 or 8 ga.)	Soundstream Power40 only (4 ga.)

Read this, or sparks will f/y!

The Soundstream REFERENCE amplifiers have extensive internal power supply capacitance, called the Ultra-Low ESR Capacitance Bank. Multiple small input power capacitors act as an internal "stiffening capacitor. Because of the large amount of internal capacitance, there may be a sizable spark when connecting the power and ground lead to the amplifier for the first time. In order to charge the capacitor bank without a spark, we suggest you do the following:

1. Connect the +12 volt cable to the amplifier and to the battery.
2. Connect one end of the ground cable to the chassis of the vehicle.
3. We have supplied a 150 ohm, 2 watt resistor with the amplifier. One leg of the resistor has been connected to the ground terminal of the amplifier.
4. To charge the capacitor bank, touch the loose end of the ground cable to the open leg of the resistor for at least 45 seconds.
5. Remove the resistor, and connect the ground wire.

CIRCUIT BREAKERS/FUSES EXTERNAL

Like all audio components, the REFERENCE amplifiers must be fused near the battery. A fuse or circuit breaker must be located within 18" of the battery. This will prevent a fire in the event of a shaded cable. See the chart on the next page to determine the correct fuse value.

(Continued on page 14)

INSTALLATION STEP 4

INSTALLATION AND MOUNTING

1. AMPLIFIER LOCATION

The REFERENCE amplifiers employ highly efficient circuitry and a unique Chassisink™ design to maintain lower operating temperatures. Additional cooling may be required if the amplifier is located in a tightly confined area or when driving especially low impedance loads at extremely high levels.

When mounting the amplifier, it should be securely mounted to either a panel in the vehicle or an amp board or rack that is securely mounted to the vehicle. The mounting location should be either in the passenger compartment or in the trunk of the vehicle, away from moisture, stray or moving objects, and major electrical components. To provide adequate ventilation, mount the amplifier so that there are at least two inches of freely circulating air above and to the sides of it.

2. SWITCHES

Set the Coherent Stereo™/Mixed-Mono/Bridged Mono and crossover switches on the bottom of the amplifier to the appropriate positions before bolting down the amplifier (see pages 20 - 25). Be sure to replace the hole plugs.

3. MOUNTING THE AMPLIFIER

- Using the amplifier as a template, mark the mounting surface.
- Remove the amplifier and drill the holes.
- Mount the amplifier to the surface using the provided hardware.

4. WIRING

- Run and connect the audio signal and remote turn-on cables to the amplifier from the source unit.
- Carefully run the positive cable from the amplifier to a fuse or circuit breaker within 18" of the battery
- Connect the fuse or circuit breaker to the battery. Leave the circuit breaker off or the fuse out until everything is bolted down.
- Secure the ground cable to a solid chassis ground on the vehicle. It may be necessary to sand paint down to raw metal for a good connection.
- Double check each and every connection!
- Re-connect the fuse or circuit breaker.

NOTE: There may be a sizable spark when connecting the power and ground lead to the amplifier for the first time. Please see the comment on page "11" for information about connecting power and ground wires to your amplifier.

5. POWER UP

Power up the system and look at the red High Power LED: there may be a 2 -3 second delay from the time the the source unit is turned on to the time that the LED on the amp turns on, which is normal. Once the amplifier power LED is on and the source unit is playing, you should have sound coming from the speakers.

(Continued From page 13)

INTERNAL

The REFERENCE amplifiers are fused with automotive-type fuses. In the event of blown power supply fuses, the "Fault" indicator on the top panel will light. The fuses are accessible via a plastic plug on the bottom of the amplifier. See the chart below to determine the fuse value. Never replace the fuses with a higher value than what is supplied. *This may result in amplifier damage and will void the warranty!*

Amplifier Fuse Values

Amplifier	Amplifier Fuse	Battery Fuse / Circuit Breaker
REFERENCE414s	(2) 25 amp automotive	60 amp
REFERENCE644s	(2) 30 amp automotive	80 amp

REMOTE TURN-ON

Connect the "Remote" to the turn-on lead from the source unit. When +12 volts is received, the amplifier will turn on.

SIGNAL CABLE

Use a high-quality cable that will be easy to install and has minimal signal loss to guarantee optimum performance. Soundstream's DL-1 and SL-1 are ideal when using the Unbalanced RCA inputs. (While using the Balanced DIN input on the Reference644s, use the cable supplied with the BLT™ or BLT4™).

SPEAKER CABLE

The REFERENCE amps will accept up to 8 gauge speaker cable. Use a high quality, flexible, multi-strand cable for best performance and longevity. Soundstream Speaker120 & 160 (12 and 16 gauge) are ideal.

WIRING DIAGRAM

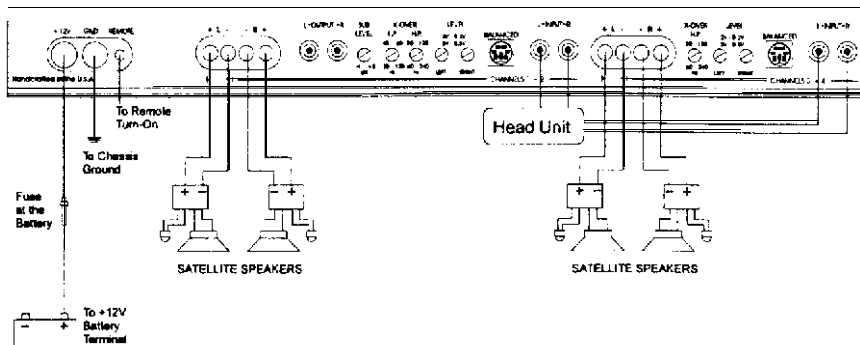

INSTALLATION STEP 5

LEVEL SETTING

The input levels are adjusted by means of the individual channel input level controls located on the front of the amplifier. This is a unique dual-stage circuit that adjusts both level and gain. This topology maintains better Signal-to-Noise ratios even when using sources with minimal output.

In the ideal situation, all components in the audio system reach maximum undistorted output at the same time. The reason is because an amplifier will only make what comes into it bigger. So, if you send it a distorted signal from the head unit, the amplifier is going to amplify distorted information. The same thing holds true if an outboard processor or crossover begins to distort before you have maximum output from the amplifier. By setting all components to reach clipping at the same time, you can maximize the output of your system. For the REFERENCE amplifiers, follow the steps below for the quickest, easiest means of setting the levels.

Level Setting the Reference414s

1. Turn the amp's input levels to minimum position (fully counter-clockwise).
2. Set source unit volume to approximately 3/4 of full volume.
3. While playing dynamic source material, slowly increase the amplifier's input level until a near maximum undistorted level is heard in the system.
4. Continue to adjust the gains independently in order to adjust the desired balance between satellite speakers and subwoofers.



NOTE: Even though the S/N ratio with low output sources is better with the REFERENCE414s amplifier than others, your best combination of output level and Signal-to-Noise ratio will be achieved when the input levels are set between 1.0 V and 5.0 V.

Level Setting the Reference644s

1. Turn the amp's input levels to minimum position (fully counter-clockwise). If any channel is in low pass mode, set the subwoofer level pot to the 0 dB position (12 o'clock).
2. Begin with the input level switches in the 0.5 5.0 Volt position.
3. Set source unit volume to approximately 3/4 of full volume.
4. While playing dynamic source material, slowly increase the amplifier's input levels until a near maximum undistorted level is heard in the system.
5. If you can't get enough gain out of the amplifier, set the input level switch to the 0.2 2.0 Volt position, and repeat steps 3 and 4.
6. If any channel is in low pass mode, you may have to adjust the subwoofer level control pot to achieve a good balance between satellites and subwoofers.

NOTE: It may be necessary to adjust the balance between low and high pass levels after listening to the system. These settings are dependent upon personal preference.

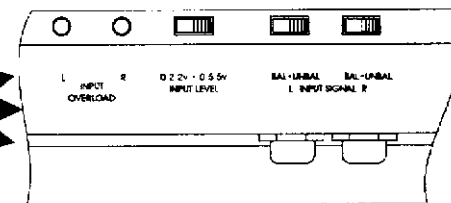

If your preamplifier / source unit has an extremely high output level, be sure to pay attention to the clipping indicators located on the top of the amplifier. These indicators will notify you if you are clipping the **PREAMPLIFIER** stage of the amplifier. If the amplifier's output is distorted and the clipping lights are **not** blinking, you are most likely clipping the **OUTPUTS** of the amplifier, or driving the speaker to distortion.

There is an additional control for subwoofer level adjustment on the Reference644s. The purpose of this control is to provide additional range of adjustment for the subwoofer signal in relation to the high pass signal. This control adjusts the level of any channels or RCA signal outputs in low pass mode.

INSTALLATION STEP 6

CROSSOVER ADJUSTMENTS

The REFERENCE644s and REFERENCE414s amplifiers incorporate an on-board staggered electronic crossover. They also have RCA outputs to drive an external amplifier. No external electronic crossover is necessary. The high and low pass portions of the crossover can be set independently of one another.

In most car audio installations, there is a tendency for a "midbass boom." Because of their interior dimensions, most cars will resonate or ring at these midbass frequencies. If we design the system so there is less musical information in this region, the final response is very smooth and natural sounding. The high pass filter is variable from 60 to 240 Hz at 12 dB/octave, while the low pass filter is variable from 30 to 120 Hz at 24 dB/octave.

For initial crossover setup, try setting the low pass filter to approximately 60 Hz, and the high pass filter(s) to approximately 100 Hz. Change the crossover points to accommodate a good mixture of frequency response, power handling, and personal preference.

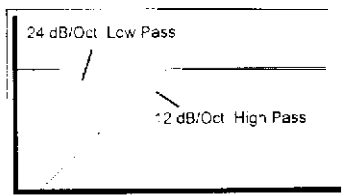

REFERENCE414s ONLY: When any channel is configured in low pass it will be controlled by channels 1 & 2 gain controls. If you are going to configure one set of channels in high pass and one set of channels in low pass, **always use channels 1 & 2 for low pass.** (See SAMPLE SYSTEM #4)

NOTE: RCA signal output in high pass, low pass and full range is derived from Channels 1 & 2 input on the REFERENCE414s. When the RCA signal output is in low pass on the REFERENCE644s the signal is summed from Channels 1, 2, 3 & 4 input. The Subwoofer Level adjustment on the REFERENCE644s also applies to the RCA signal outputs.

AIRBASS™ ACCESSORY OPTION

Soundstream's new AIRBASS™ feature can be added to the REFERENCE644s & REFERENCE414s amplifiers. This feature allows wireless RF remote control level adjustment of the amplifier, while the low pass filter on the amplifier's internal crossover is engaged. (AIRBASS™ does not control the level of the RCA signal outputs.)



NOTE: The AIRBASS™ accessory is intended to be used only while the REFERENCE amplifiers are driving a subwoofer(s). When the AIRBASS™ accessory is added to a REFERENCE414s and REFERENCE644s, it controls the level of any channel receiving information from the low pass filter in the amplifier. The Coherent Stereo™ / Mixed Mono / Bridged Mono switches still function as normal.

Installing AIRBASS™ involves removing the bottom plate of the amplifier, adding the AIRBASS™ circuit board, and flipping a switch. The switch is labeled on the amplifier's main circuit board. DO NOT set the AIRBASS™ switch to the "IN" position unless the AIRBASS™ module has been added. DO NOT move the AIRBASS™ switch while the amplifier is "ON". Doing so may damage your speakers. (Please refer to the AIRBASS™ owner's / installation manual for more details.)

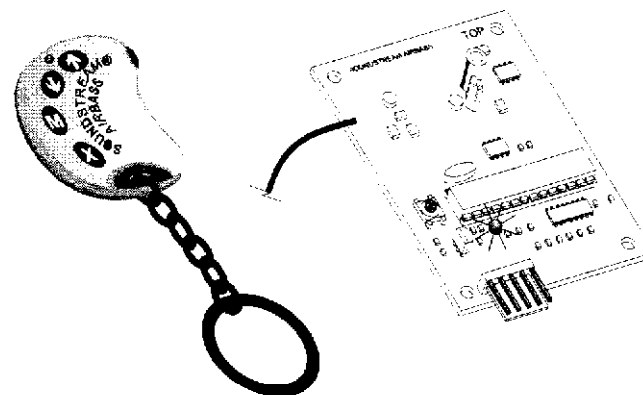

SAMPLE SYSTEM #1

(Reference414s and Reference644s)
4 channels of RCA input
4 stereo channels of full range output

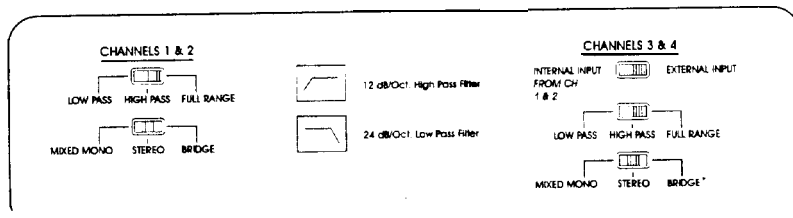
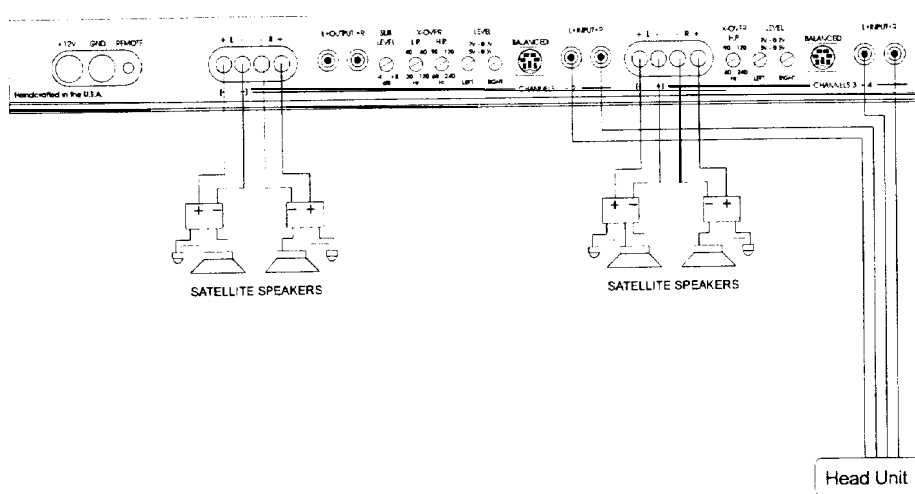

SAMPLE SYSTEM #2

(Reference414s and Reference644s)
4 channels of RCA input
4 stereo channels of high pass output
RCA line output set to low pass
Line output to an external amplifier driving subwoofers

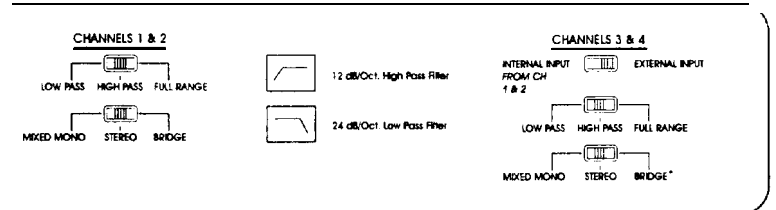
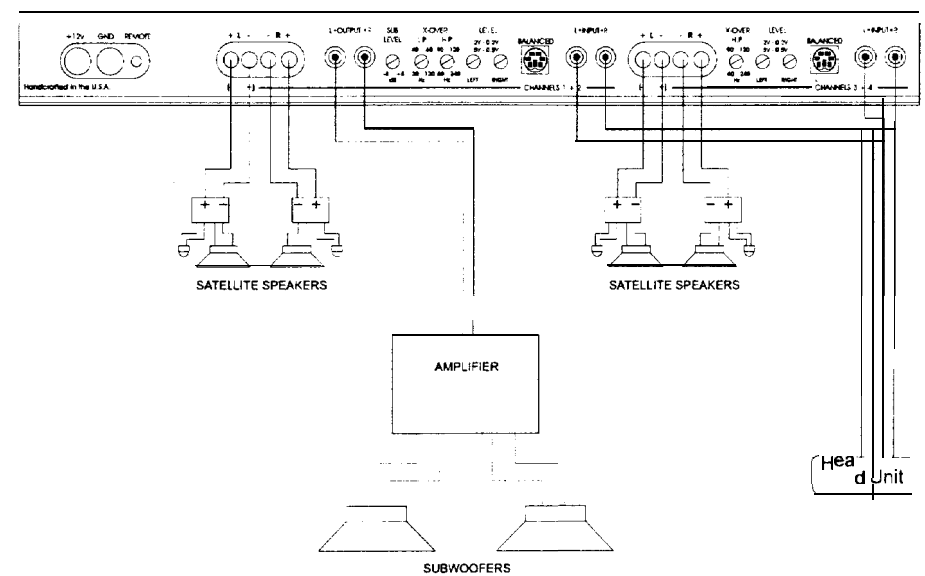

SAMPLE SYSTEM #3

(Reference414s and Reference644s)

2 channels of RCA input

4 stereo channels of high pass output

RCA line output set to low pass

Line output to an external amplifier driving subwoofers

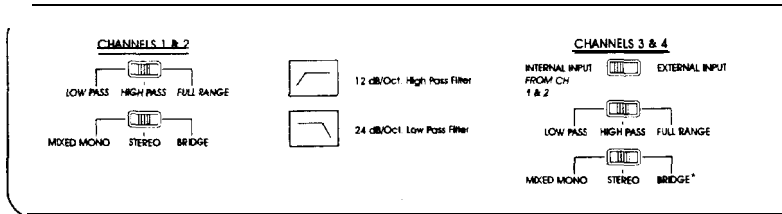
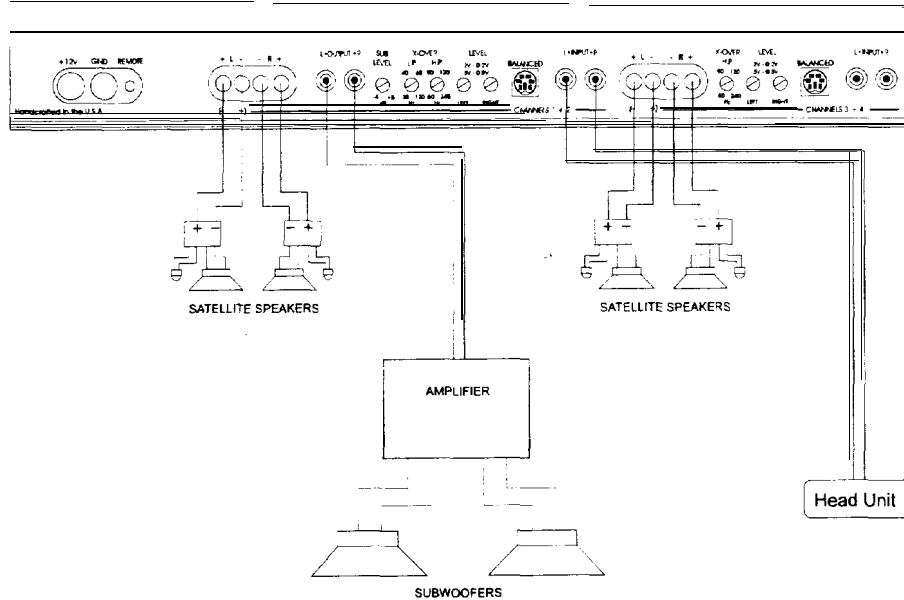

SAMPLE SYSTEM #4

(Reference414s and Reference644s)

4 channels of RCA input

2 stereo channels of high pass output

1 bridged channel of low pass output

(NOTE 644s only: Due to the internal summing circuitry of the amplifier's low pass filter, fading to the satellites will never completely defeat the subwoofers)

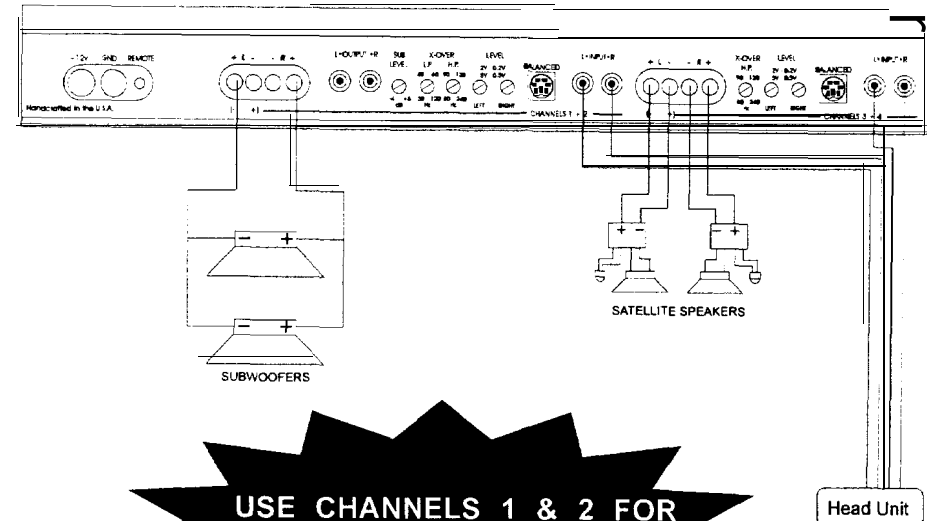

USE CHANNELS 1 & 2 FOR LOW PASS & CHANNELS 3 & 4 FOR HIGH PASS ON THE REFERENCE414S ONLY!

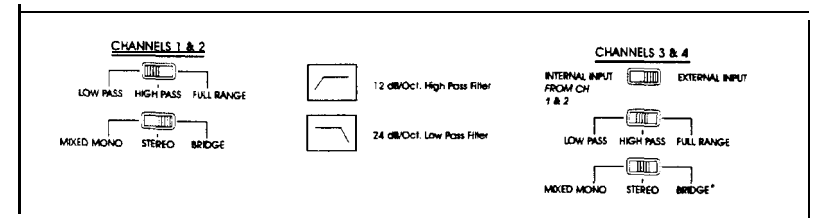

SAMPLE SYSTEM #5

(Reference414s and Reference644s)

2 channels of RCA input

2 bridged channels of low pass output

RCA line output set to high pass

Line output to an external amplifier driving satellite speakers

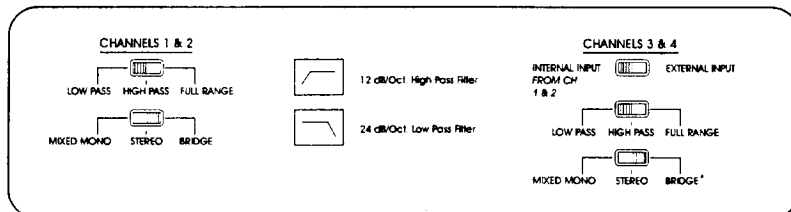
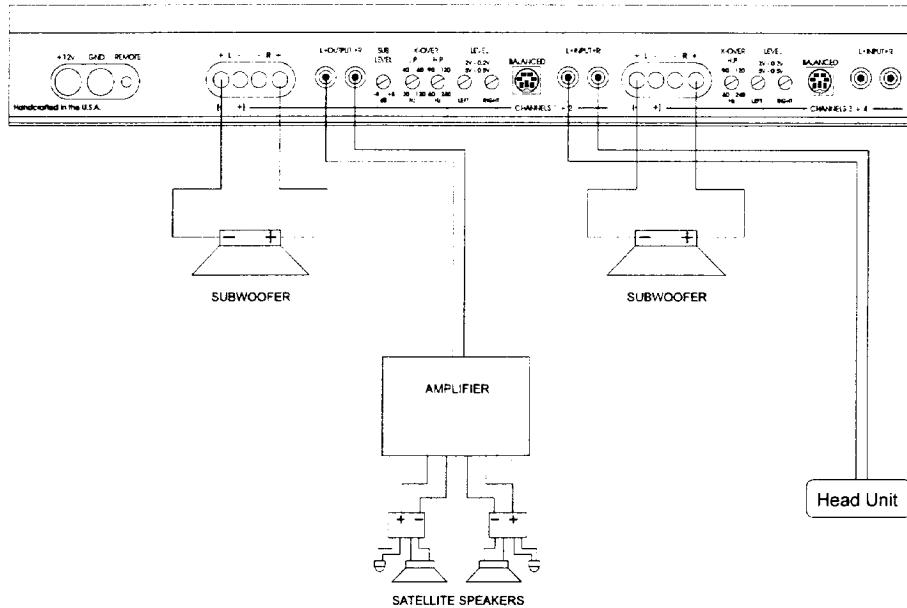

SAMPLE SYSTEM #6

(Reference414s and Reference644s)

2 channels of RCA input

2 bridged channels of high pass output

RCA line output set to low pass

Line output to an external amplifier driving subwoofers

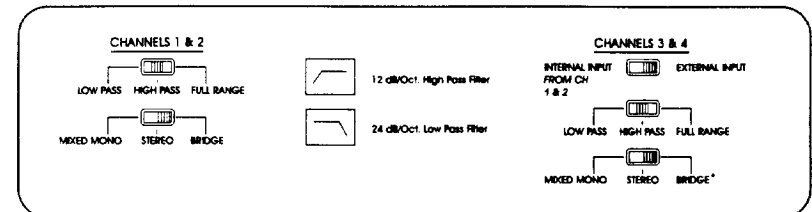
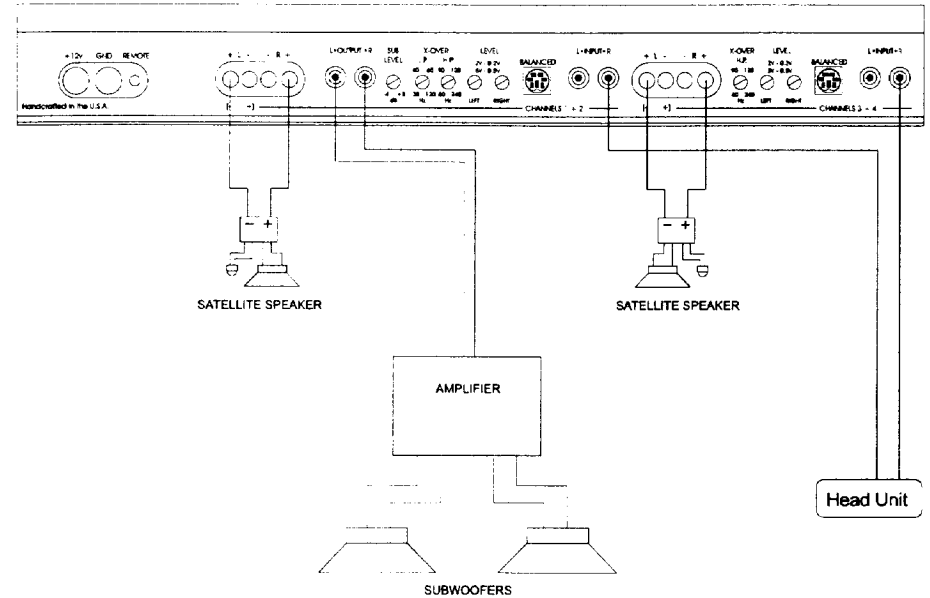

TROUBLESHOOTING

PROBLEM	CAUSE
No sound and power LED is <u>not</u> lit	<ul style="list-style-type: none"> No power or ground at amp No remote turn-on signal Blown fuse near battery
No sound, power LED is lit, and the AIRBASS™ option has not been added.	<ul style="list-style-type: none"> No signal input The AIRBASS™ switch is in the "IN" position, Move it to the "OUT" position
Fault LED is lit	<ul style="list-style-type: none"> Amp power supply fuse is blown or missing
Repeatedly blown amp fuse, frequent activation of Smart Power Supply Circuit	<ul style="list-style-type: none"> Speaker or leads may be shorted Verify adequate amplifier ventilation
Channels 1,2,3 or 4 experiencing intermittent output (Reference414s only)	<ul style="list-style-type: none"> activation of the internal circuit breakers. check to make sure channels 1-4 are driving a 1/2 ohm per channel load or greater speaker or leads may be shorted
Unable to adjust the subwoofer & midrange level separately. (Reference414s only)	<ul style="list-style-type: none"> Make sure that the subwoofers are wired to channels 1 & 2
No output from channels 3 & 4 with 1 pair of RCA inputs (Reference414s only)	<ul style="list-style-type: none"> Select "Internal from ch's 1 & 2" on ch 3 & 4 input on the bottom of the amplifier. (see pages 14 - 17)
Not enough input sensitivity while using the Balanced input (Reference644s only)	<ul style="list-style-type: none"> Be sure both Left and Right Input Signal Switches are set to the "BAL" position
Left and Right Input Overload indicators lighting (Reference644s only)	<ul style="list-style-type: none"> Input signal level is too high - readjust input gains, or select the 0.5-5V input signal level range
Alternator whine while using Unbalanced RCA inputs (Reference644s only)	<ul style="list-style-type: none"> Make sure the channel 2 Input Signal Switch is in the "UNBAL" position. Try the Input Signal Switch for channels 1, 3 & 4 in the "BAL" position; leave the switches in the quietest position. This will not affect the performance of the amplifier.

SERVICE

Your Soundstream REFERENCE amplifier is protected by a limited warranty. Please read the enclosed warranty card.

PROTECTION CIRCUITRY

Your REFERENCE amplifier is protected against both overheating and short circuits by means of the following circuits:

- Main power supply fuses
- Auto High Current™ power supply
- Circuit Breaker on each channel (Reference414s only)
- Smart Power Supply Thermal Rollback™ activating at 85°C
- A fail-safe thermal protection circuit activating at 95°C

Your amplifier also incorporates an innovative Fault Diagnosis System that identifies a blown power supply fuse.

NOTE: If you experience *blown main power supply fuses*, it is likely that the amplifier is seeing a dead short, either in the speaker wire or in the speaker itself. Rectify the problem before blowing multiple fuses! DO NOT increase values beyond the original fuse value! Doing so will void your warranty and may damage your amplifier.

SPECIFICATIONS

POWER (Watts)	4 Ω Stereo (8 Ω Bridged) at 12 VDC	2 Ω Stereo (4 Ω Bridged)	1 Ω Stereo (2 Ω Bridged)	1 1/2 Ω Stereo (1 Ω Bridged)
Reference41 4s	50 x 4 (100 x 2)	75 x 4 (150 x 2)	100x4 (200 x 2)	NA
Reference644s	75 x 4 (150 x 2)	150x4 (300 x 2)	160x4 (320 x 2)	160x4 (320 x 2)

THD	<0.1%
Signal-to-Noise	>100 dB
Frequency Response	20 Hz to 20 kHz ± 0.5 dB
Stereo Separation	>90 dB
Damping	>200
Input Sensitivity (Ref414s):	200mV - 5.0V (Ref414s)
(Ref644s):	200mV - 2.0V, or 500mV to 5.0V (Ref644s)
Input Impedance	1 OK ohms
Crossover Output	340 mV output w/ 200 mV input (+4.5 dB)

Crossover Specifications

Low Pass: 30 - 120 Hz at 24 dB/octave
 High Pass: 60 - 240 Hz at 12 dB/octave

Dimensions (Ref414s): 15.25" W x 2.25" H x 9.8"D
 (Ref644s): 16.5" W x 2.25" H x 9.8"D

SERIES AND PARALLEL WIRING

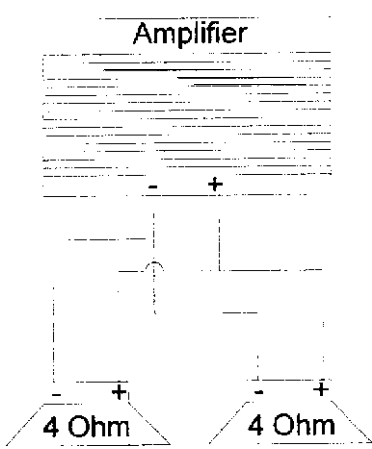

**2-4 ohm drivers in parallel
= 2 ohms**

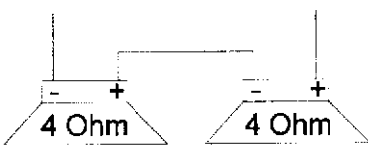
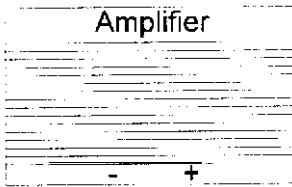

**2-4 ohm drivers in series
= 8 ohms**

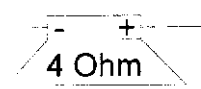
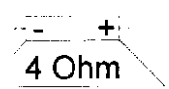
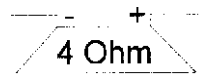
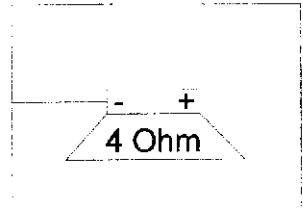
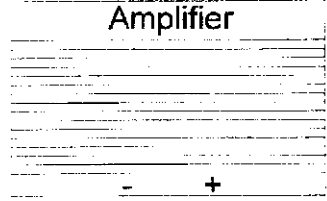

**4-4 ohm drivers in parallel
= 1 ohm**

SOUNDSTREAM TECHNOLOGIES
120 Blue Ravine Road · Folsom · California 95630
ph 916.351.1288 · fax 916.351.0414

rev A - 3.27.97

Free Manuals Download Website

<http://myh66.com>

<http://usermanuals.us>

<http://www.somanuals.com>

<http://www.4manuals.cc>

<http://www.manual-lib.com>

<http://www.404manual.com>

<http://www.luxmanual.com>

<http://aubethermostatmanual.com>

Golf course search by state

<http://golfingnear.com>

Email search by domain

<http://emailbydomain.com>

Auto manuals search

<http://auto.somanuals.com>

TV manuals search

<http://tv.somanuals.com>