REFERENCE
405
Power Amplifier

**OWNERS MANUAL
AND
INSTALLATION GUIDE**

SOUNDSTREAM[®]
T E C H N O L O G I E S

CONGRATULATIONS

You now own the **REFERENCE405 Amplifier**, the product of an uncompromising design and engineering philosophy. Your Soundstream REFERENCE amplifier will outperform any other amplifier in the world.

To maximize the performance of your system, we recommend that you thoroughly acquaint yourself with its capabilities and features. Please retain this manual and your sales and installation receipts for future reference.

Soundstream amplifiers are the result of American craftsmanship and the highest quality control standards, and when properly installed, should provide you with many years of listening pleasure. Should your amplifier ever need service or replacement due to theft, please record the following information, which will help protect your investment.

Model and Serial # _____

Dealer's Name _____

Date of Purchase _____

Installation Shop _____

Installation Date _____

CAUTION!

Prolonged listening at high levels may result in hearing loss. Even though your new Soundstream REFERENCE amplifier sounds better than anything you've ever heard, exercise caution to prevent hearing damage.

DESIGN FEATURES

- Uncompromising Design and Construction including mil-spec glass epoxy circuit boards and high current custom gold-plated solid brass connections that will accept up to 4 gauge power/ground wire.
- **High Power/High Current Capability** (Subwoofer channel) - Soundstream's exclusive circuit which permits customization of your amplifier to its particular application--high current, low impedance loads (multiple subwoofer, 1 ohm or less) or high power, higher impedance loads (greater than 1 ohm).
- **Chassisink™ Darlington Power Array** - Soundstream's "over-building" of the output section incorporates several output transistors instead of a few to deliver more power, faster. The transistors are directly sandwiched between the circuit board and the heatsink in a design called Chassisink™ to ensure cool, efficient amplifier operation.
- **Staggered Asymmetrical Electronic Crossover** - Continuously variable crossover with 24 dB/octave low pass and 12 dB/octave high pass.
- **PowerGrid Power Supply Design** - All power supply components are located near one another, connected by thick, wide PCB traces, which ensures rapid high current delivery. The entire power supply section is isolated on one side of the circuit board while the audio stage is located on the other, guaranteeing minimal noise.
- **Ultra-Low ESR Capacitance Bank** - Multiple small input power capacitors are used to provide a lower ESR (Equivalent Series Resistance), which means the capacitors are able to provide more current, faster.
- **Smart Thermal Rollback Power Supply** - Most amplifiers shut off when they get too hot. In the unlikely event the REFERENCE405 reaches 85°C, it will roll back average power output capability (without affecting the dynamics) until the amp cools off, when full capability is restored. If overheating should continue, a second thermal sensing protection circuit will shut off the amplifier if the heatsink reaches 95°C.
- **Unregulated Power Supply** - 4 ohm power ratings are measured at 12 volts, which means substantially greater output in the real world when the vehicle is running, where voltages range from 13.2 to 14.4 volts. Dynamic capability of the loosely regulated power supply is much greater than that of a tightly regulated power supply.
- **Fault Monitor LED** on the front panel notifies you of blown power supply fuses.
- **112 Ohm Drive Ability** - The REFERENCE405 subwoofer channel is designed to drive nearly any load--all the way down to a 1/2 Ohm load!
- **Five Dual Discrete Class A Drive Stages** - Over six times the drive current of most amps, which maintains performance into low impedance loads.
- **Drive Delay™ Muted Turn-on/off Circuit** - A unique circuit which completely eliminates any amplifier-related turn-on/off noises.
- **Flexible Input Sensitivity** accepts input voltages from 100 mV to 2.5 V, which permits maximum output from amplifier with virtually any source unit.
- **Balanced Input Design** for added immunity to noise caused by component and vehicle electrical system interaction.

SYSTEM DIAGRAM # 1

Channels of input: 4
 Bridged Channels: none
 Subwoofer Channel Impedance: 2 ohms
 High Power/High Current Setting: High Power

SYSTEM DIAGRAM # 2

Channels of input: 2
 Bridged Channels: none
 Subwoofer Channel Impedance: 4 ohms
 High Power/High Current Setting: High Power

SOUNDSTREAM
 TECHNOLOGIES

Front Panel Connections

REFERENCE 405

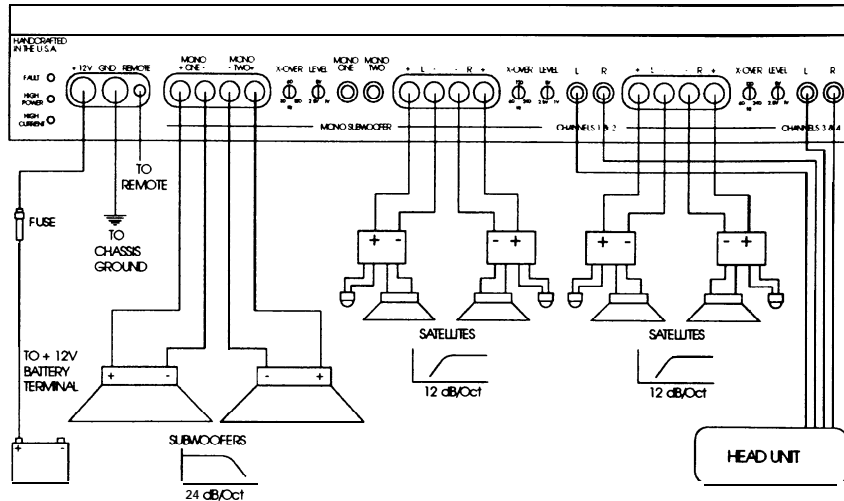

SOUNDSTREAM
 TECHNOLOGIES

Front Panel Connections

REFERENCE 405

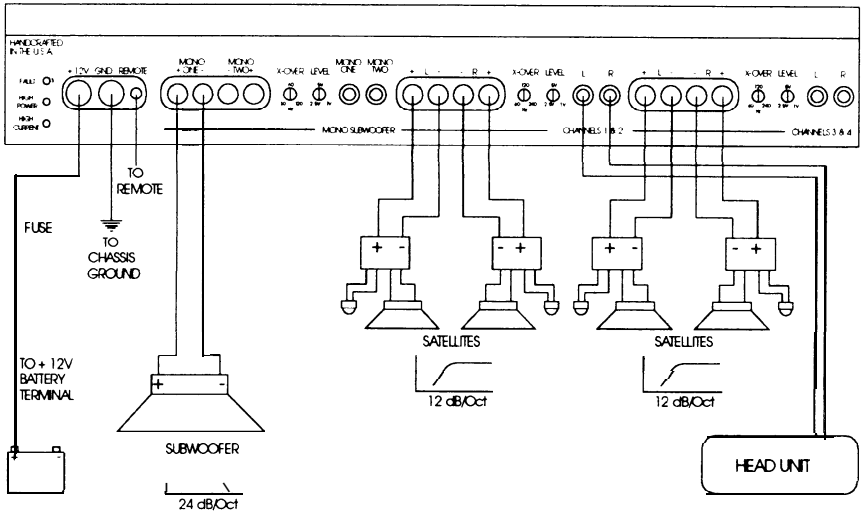

Bottom Panel Switch Settings

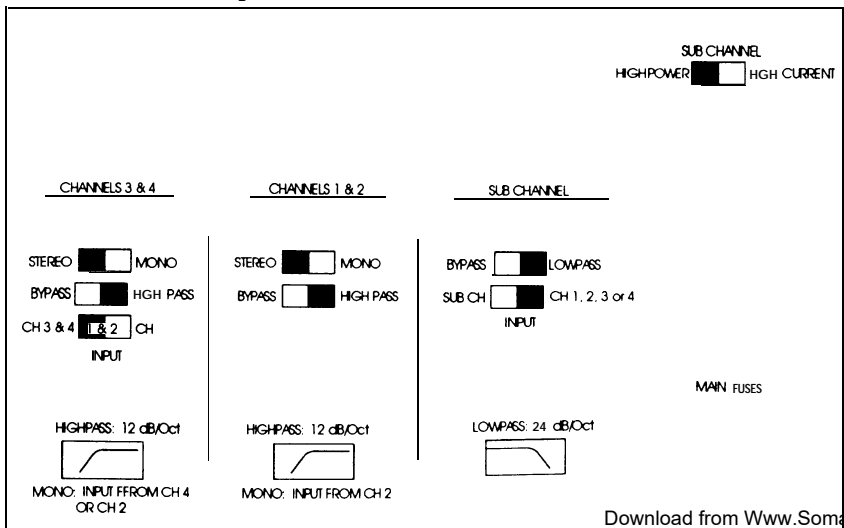

Bottom Panel Switch Settings

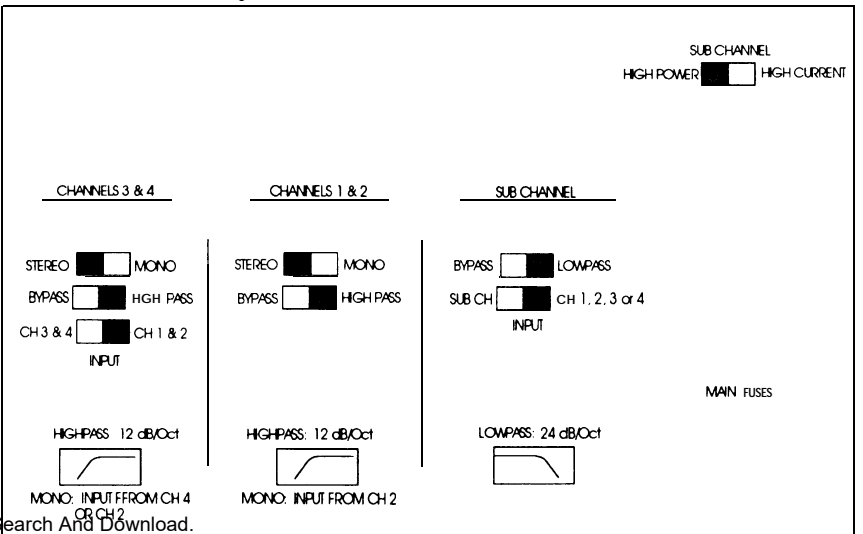

SYSTEM DIAGRAM# 3

Channels of input: 6
 Bridged Channels: none
 Subwofer Channel Impedance: 2 ohms
 High Power/High Current Setting: High Power
 *Using outboard "dual amp balancer" to remotely adjust subwoofer level.

SOUNDSTREAM
 TECHNOLOGIES

REFERENCE 405

Front Panel Connections

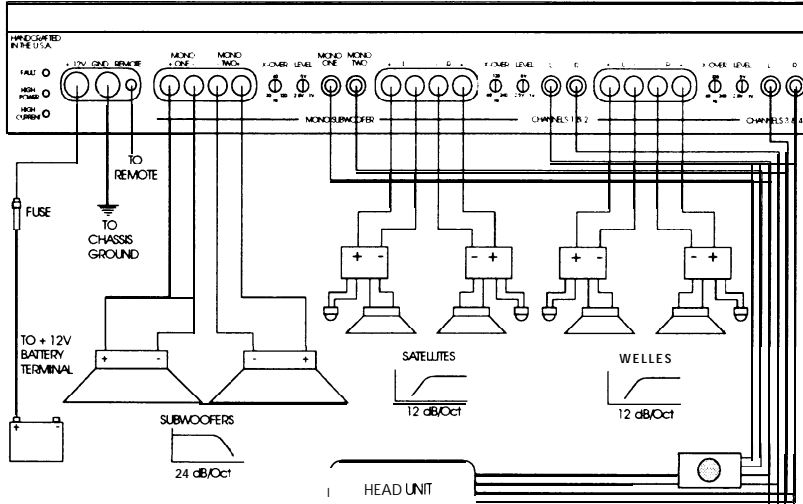

Bottom Panel Switch Settings

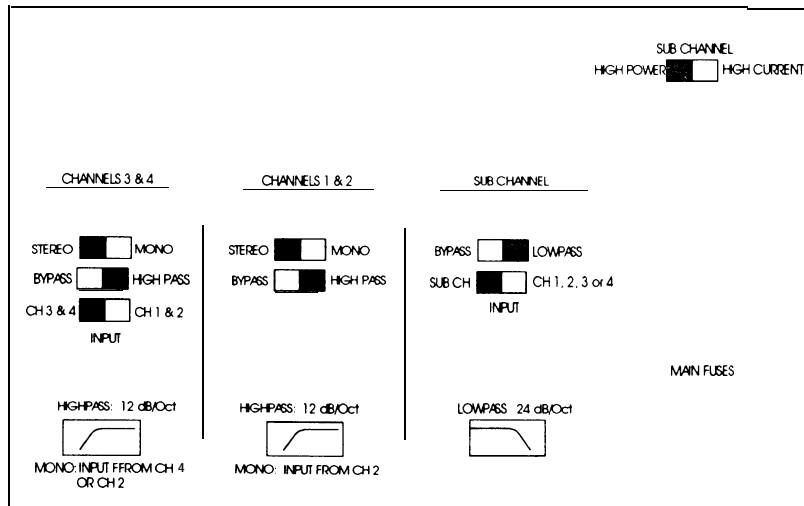

SYSTEM DIAGRAM# 4

Channels of input: 2
 Bridged Channels: 1 & 2, 3 & 4
 Subwofer Channel Impedance: < 1 ohm
 High Power/High Current Setting: High Current

SOUNDSTREAM
 TECHNOLOGIES

REFERENCE 405

Front Panel Connections

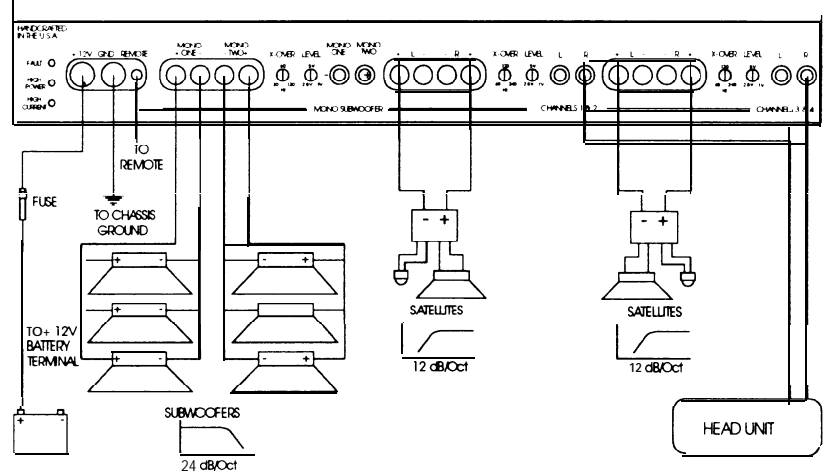

Bottom Panel Switch Settings

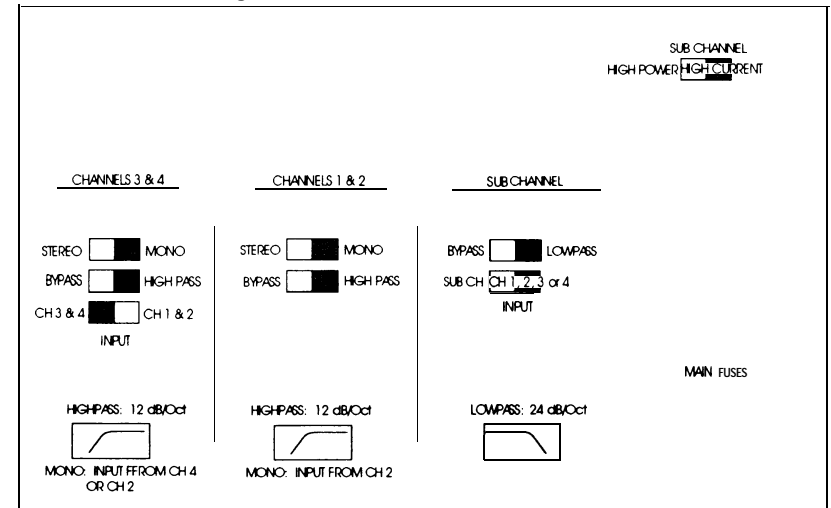

INSTALLATION

1. PLAN THE INSTALLATION

Before you go any further with the installation of the amplifier, map out the system and the necessary wiring. Your work will be simplified if you have a plan of attack. Consider all electrical requirements, as well as physical, such as amplifier ventilation and availability of space.

2. SELECT OPERATING MODES (on underside)

The configuration switches are accessible by removing the plugs on the underside of the amplifier. They allow you to determine the operating configuration of the amplifier, including:

- 5 or 3 channels of input (via bridging)
- normal (High Power) or low impedance (High Current) operation with the subwoofer channel
- number of channels of input to drive the amplifier
- crossover activation for the subwoofer, front, and rear channels

A. Stereo/Bridged Mono (see System Diagrams #1- 4)

Each pair of the 4 channels rated at 25 watts each (12 volts) can be bridged mono. If running either pair of channels in mono, be sure to set the switch for the appropriate pair to "mono."

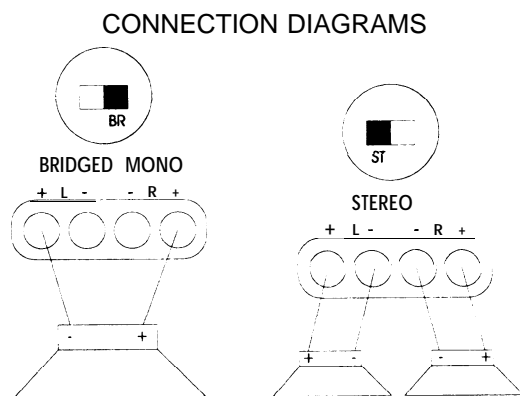

B. Crossover Settings

- Each pair of the 4 channels rated at 25 watts each (12 volts) can be set to operate either full range or high pass. To use the built-in high pass crossover, select high pass. If you are using the mono channel full range or with an external crossover, select bypass.

- The mono channel can be set to operate either full range or low pass. To use the low pass crossover, select low pass; to operate the channel up to 400 Hz (for use with an external crossover), select bypass.

C. High Power/High Current (mono channel)

The mono channel can be set to operate in either high power or high current mode. Select the mode of operation as follows:

**1 Ohm or higher
less than 1 Ohm**

**High Power
High Current**

The REFERENCE405 subwoofer channel is designed to drive extremely low impedances. Be sure that the High Power/High Current switch is in the appropriate setting for best performance and maximum reliability.

D. Inputs (see System Diagrams #1- 4)

All five channels of the REFERENCE405 can be driven with 2, 4, or 6 channels of input. If your head unit has one or two pairs of outputs, you can drive all 5 channels of the amplifier.

<i>Channels of Input</i>		
<i># of channels of input</i>	<i>Switch setting for each set of channels</i>	
	3 & 4	Subwoofer
2	1 & 2	1, 2, 3 or 4
4	3 & 4	1, 2, 3 or 4
6	3 & 4	SUB CH

NOTE: Channels 1 & 2 are not listed. These channels must always receive input in order for operation of all 5 channels.

3. LOCATION OF THE AMPLIFIER

When mounting the amplifier, it should be securely mounted to either a panel in the vehicle or an amp board or rack that is securely mounted to the vehicle. The mounting location should be either in the passenger compartment or in the trunk of the vehicle, away from moisture, stray or moving objects, and major electrical components (electric motors, fuel pumps, etc.). To provide adequate ventilation, mount the amplifier so there are at least 2 inches of freely circulating air above and to the sides of it.

4. MOUNTING OF THE AMPLIFIER

1. Using the amplifier as a template, mark the mounting surface.
2. Remove the amplifier and drill the holes.
3. Mount the amplifier to the surface using the provided hardware.

5. WIRING

The only tool needed to make wire terminations at the amplifier will be a flat blade-type screwdriver and either wire strippers or a knife. When baring wires for connection to the amplifier, remove approximately 5/8" of the insulation, insert into the terminal block, and tighten the screw. Determine from the chart below the minimum gauge power and ground wire for your application.

up to 5'	up to 10'	greater than 10'
Soundstream Power40 or Power80 (4 or 8 ga.)	Soundstream Power40 or Power80 (4 or 8 ga.)	Soundstream Power40 (4 ga.)

Wiring Tips

- Use grommets when running cables through any metal or sharp plastic to prevent accidental shorting or shearing.
 - Be certain that the cables don't interfere with normal operation of the vehicle.
 - Choose the location of the audio cables carefully to prevent interference with the vehicle's high current circuits and vehicle management systems (engine computers, relays, etc.).
1. **Carefully run the audio and remote turn-on cables to the amplifier.**
 2. **Connect the speakers** as shown in "Selecting Operating Modes" in section 2. Use at least a 16 gauge speaker wire, preferably a flexible multi-strand cable, such as Soundstream Speaker 160 or Speaker 120.
 3. **Carefully run the positive power cable from the battery to a fuse or a circuit breaker and then to the amplifier.** Connect the lead to the battery via either a fuse or circuit breaker within 18 inches of the battery. The fuse or circuit breaker value should be 40 to 50 amps. Leave the fuse out or the circuit breaker off until the installation is otherwise finished. If the circuit breaker cannot be shut off manually, do not make the final power connection until the installation is finished.
 4. **Run a ground cable for the amplifier** and securely connect it to a solid chassis ground on the vehicle. The ground cable should be the same gauge as the power cable.
 5. **Double check each and every connection.**
 6. **Reconnect the fuse or circuit breaker.** Power up the system and look at the green and red LEDs, depending on the configuration, one should be lit. There may be a 2 - 3 second delay from the time that the source unit is turned on to the time that the LED on the amp turns on, which is normal. Once the

amplifier power LED is on and the source unit is playing, you should have sound coming from the speakers.

6. LEVEL SETTING

The input levels are adjusted by means of the input level controls located between the RCA inputs and the speaker outputs. When the amplifier is operated in the mono/bridged mode, only the right channel input is active.

1. Turn the amp's input level controls to minimum position (fully counter-clockwise).
2. Set source unit volume to approximately 3/4 of full volume.
3. While playing dynamic source material, slowly increase the amplifier's input level(s) until a near maximum undistorted level is heard in the system.
NOTE: The best Signal to Noise ratio is achieved when the amplifier input gains are set between 500 mV and 2.5 V.

7. CROSSOVER ADJUSTMENTS

The REFERENCE405 incorporates a continuously variable staggered asymmetrical electronic crossover. The high and low pass portions of the crossover can be adjusted independent of one another. Follow the below procedure to adjust the crossover:

1. Make certain the crossover is activated (see Section 2B, Select Operating Modes).
2. Set crossover frequency adjustments to the 12 o'clock position.
3. While listening to music, adjust the high pass frequency dial for the high pass. Select a frequency high enough to prevent damage to the speakers, yet low enough that you are able to retain midbass in the front speakers.
4. Adjust the subwoofer frequency control in the same way as the high pass. This time, listen to bass. You should find a setting that will give you a solid sound with minimum "boom" from resonating frequencies.

Note; Many times, the best results are achieved with the high pass frequencies set higher than the low pass. This "staggered" setting compensates for much of the midbass resonance inherent in the automobile environment.

You may find it necessary to readjust the crossover after listening to the system. The correct settings are a combination of the capabilities of the equipment and your listening preferences.

8. PROTECTION CIRCUITS

Your REFERENCE405 amplifier is protected against both overheating and short circuits by means of the following circuits:

- Main power supply fuses (2 at 20 amps each)
- Smart Power Supply Thermal Rollback activating at 85°C.
- A fail-safe thermal protection circuit activating at 95°C.
- Speaker over-current protection relays (on the 4 x 25 watt channels).

Your amplifier also incorporates an innovative Fault Diagnosis system that identifies a blown power supply fuse.

- *If you experience blown main power fuses, DO NOT increase values beyond 20 amp (each) fuses.*

9. TROUBLESHOOTING

PROBLEM	CAUSE
No sound and LEDs are not lit	<ul style="list-style-type: none"> • no power or ground at amp • no remote turn-on signal • blown fuse near battery
Fault LED is lit	<ul style="list-style-type: none"> • amp power supply fuse is blown
Repeatedly blown amp fuse, frequent activation of Smart Power Supply Circuit or speaker protection circuit breakers	<ul style="list-style-type: none"> • check speaker configuration, amp may be in "High Power" mode, put amp into "High Current" mode if speaker load is less than 2 Ohms (see <i>Section 2, Selecting Operating Modes</i>) • speaker or leads may be shorted • verify adequate amplifier ventilation
no sound from subwoofer channel with 2 or 4 channels of input	<ul style="list-style-type: none"> • check input settings on bottom of amplifier--switch should be set at inputs "1, 2, 3 or 4" unless using external inputs
no sound from channels 3 & 4 with 2 channels of input	<ul style="list-style-type: none"> • check input settings on bottom of amplifier--switch should be set at inputs "1 & 2"

10. SERVICE

Your Soundstream amplifier is protected by a limited warranty. Please read the enclosed warranty card.

11. SPECIFICATIONS

POWER OUTPUT

- 25 watts x 4 plus 100 watts x 1 (4 ohms, 12 V)
- 50 watts x 1 (4 ohms, 12 V, High Current)
- 40 watts x 4 plus 120 watts x 1 (4 ohms, 14.4 V)
- 200 watts x 1 (2 ohms)
- >240 watts x 1 (1 or 1/2 ohm)

- THD: <0.1%
- Signal to Noise: >100 dB
- Frequency Response: 20 Hz to 20 kHz +/- 0.5 dB (dedicated sub channel): 20 Hz to 400 Hz +/- 0.5 dB
- Bandwidth: 15 Hz to 50 kHz (dedicated sub channel): 15 Hz to 1 kHz
- Stereo Separation: >90 dB
- Damping: >200
- Input Sensitivity: 100 mV - 2.5 V
- Input Impedance: 12 k ohms

Crossover Specifications:

- High Pass: 12 dB/octave, Continuously Variable from 60 - 240 Hz (front & rear)
- Low Pass: 24 dB/octave, Continuously Variable from 30 - 120 Hz

Dimensions: 16" W x 9-1/2" D x 2-1/4" H

SPEAKER WIRING CONFIGURATIONS

Two 4 Ohm Speakers
In Parallel = 2 Ohms

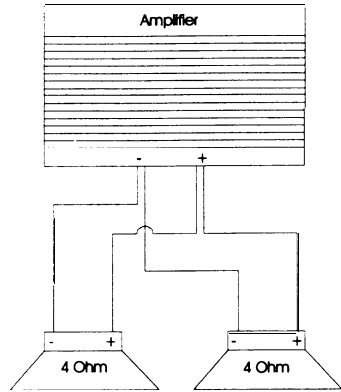

Four 4 Ohm Speakers
In Parallel = 1 Ohm

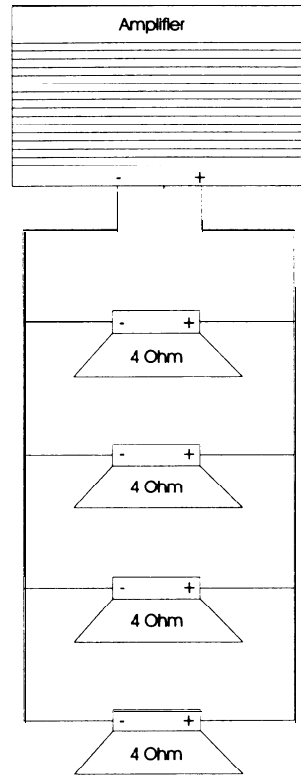

Two 4 Ohm Speakers
In Series = 8 Ohms

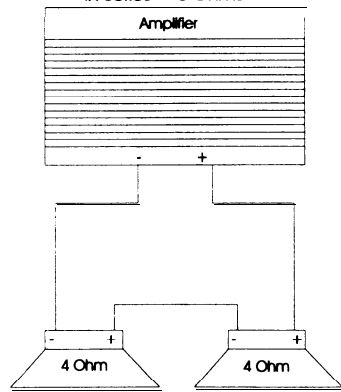

SOUNDSTREAM TECHNOLOGIES

120 Blue Ravine Road .Folsom · California 95630 USA
tel 916.351 .1288 fax 916.351.0414 ver 2.07a

Free Manuals Download Website

<http://myh66.com>

<http://usermanuals.us>

<http://www.somanuals.com>

<http://www.4manuals.cc>

<http://www.manual-lib.com>

<http://www.404manual.com>

<http://www.luxmanual.com>

<http://aubethermostatmanual.com>

Golf course search by state

<http://golfingnear.com>

Email search by domain

<http://emailbydomain.com>

Auto manuals search

<http://auto.somanuals.com>

TV manuals search

<http://tv.somanuals.com>