

IMPORTANT FOR FUTURE REFERENCE

Please complete this information and retain this manual for the life of the equipment:

Model #: _____

Serial #: _____

Date Purchased: _____

MANUAL & SilverStar ON OVENS

Marathoner Gold Models

GB/12CCH	GB/22CCH	GS/12CCH	GS/22CCH
GB/12PC	GB/22PC	GS/12PC	GS/22PC
GB/12RT	GB/22RT	GS/12RT	GS/22RT
GB/12SC	GB/22SC	GS/12SC	GS/22SC
GB/15CCH	GB/25CCH	GS/15CCH	GS/25CCH
GB/15PC	GB/25PC	GS/15PC	GS/25PC
GB/15RT	GB/25RT	GS/15RT	GS/25RT
GB/15SC	GB/25SC	GS/15SC	GS/25SC

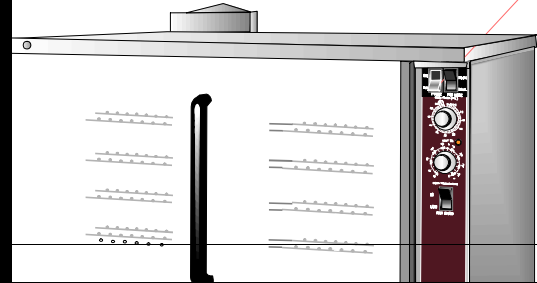

SAFETY PRECAUTIONS

Before installing and operating this equipment, be sure everyone involved in its operation is fully trained and aware of precautions. Accidents and problems can be caused by failure to follow fundamental rules and precautions.

The following symbols, found throughout this manual, alert you to potentially dangerous conditions to the operator, service personnel, or to the equipment.



This symbol warns of immediate hazards which will result in severe injury or death.



This symbol refers to a potential hazard or unsafe practice which could result in injury or death.



This symbol refers to a potential hazard or unsafe practice which could result in injury, product damage, or property damage.



This symbol refers to information that needs special attention or must be fully understood, even though not dangerous.

 **WARNING**
FIRE HAZARD
FOR YOUR SAFETY

Do not store or use gasoline or other flammable vapors and liquids in the vicinity of this or any other appliance.

Keep area around appliances free and clear of combustibles.

Purchaser of equipment must post in a prominent location detailed instructions to be followed in the event the operator smells gas. Obtain the instructions from the local gas supplier.

 **WARNING**

Asphyxiation can result from improper ventilation. Do not obstruct the flow of combustion and ventilation air to and from your cooking equipment.

NOTICE

Be sure this Operator's Manual and important papers are given to the proper authority to retain for future reference.

NOTICE

This product is intended for commercial use only. NOT FOR HOUSEHOLD USE.

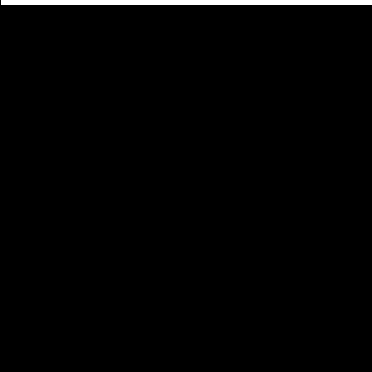

SPECIFICATIONS

MARATHONER GOLD & SILVERSTAR GAS CONVECTION OVENS

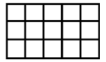

GAS SUPPLY

The serial plate is located inside the lower front panel. It indicates the type of gas the unit is equipped to burn. All Southbend equipment is adjusted at the factory. Check type of gas on serial plate.

These models are design-certified for operation on natural or propane gases. For natural gas, the regulator is set to deliver a 4.5" W.C. pressure to the manifold. For propane gas, it is set to deliver 11" W.C.

If applicable, the vent line from the gas appliance pressure regulator shall be installed to the outdoors in accordance with local codes, or in the absence of local codes, with the *National Fuel Gas Code, ANSI Z223.1, Natural Gas Installation Code, CAN/CGA-B149.1*, or the *Propane Installation Code CAN/CGA-B149.2*, as applicable.

This appliance should be connected **ONLY** to the type of gas for which it is equipped.

A 3/4" NPT line is provided at the rear for the gas connection. An adequate gas supply is imperative. Undersized or low pressure lines will restrict the volume of gas required for satisfactory performance. Fluctuations of more than 25% on natural gas or 10% on propane gas will create problems and affect burner operating characteristics.

An adequate gas supply line to the unit should be no smaller than the inside diameter of the pipe from the unit to which it is connected.

Purge the supply line to clean out dust, dirt, or other foreign matter before connecting the line to the unit.

All pipe joints and connections must be tested thoroughly for gas leaks. Use only soapy water for testing on all gases. **NEVER** use an open flame to check for gas leaks. All connections must be checked for leaks after the unit has been put into operation. Test pressure should not exceed 1/4" W.C.

Model Number	# of Ovens	Oven Depth	Type of Gas	Orifice Size	# of Burners	Total BTU
GS/12... SLGS/12...	Single-Deck	Shallow	Propane	55	3 @ 18,000 BTU	54,000
GS/15... SLGS/15...	Single-Deck	Shallow	Natural Gas	47	4 @ 18,000 BTU	72,000
GB/12... SLGB/12...	Single-Deck	Bakery	Propane	55	4 @ 18,000 BTU	72,000
GB/15... SLGB/15...	Single-Deck	Bakery	Natural Gas	47	5 @ 18,000 BTU	90,000
GS/22... SLGS/22...	Double-Deck	Shallow	Propane	55	6 @ 18,000 BTU	108,000
GS/25... SLGS/25...	Double-Deck	Shallow	Natural Gas	47	8 @ 18,000 BTU	144,000
GB/22... SLGB/22...	Double-Deck	Bakery	Propane	55	8 @ 18,000 BTU	144,000
GB/25... SLGB/25...	Double-Deck	Bakery	Natural Gas	47	10 @ 18,000 BTU	180,000



EXTERIOR DIMENSIONS

Single-Deck Ovens

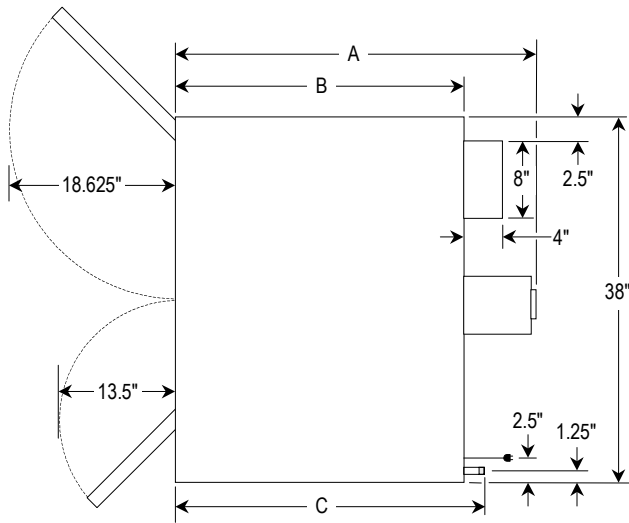

TOP VIEW

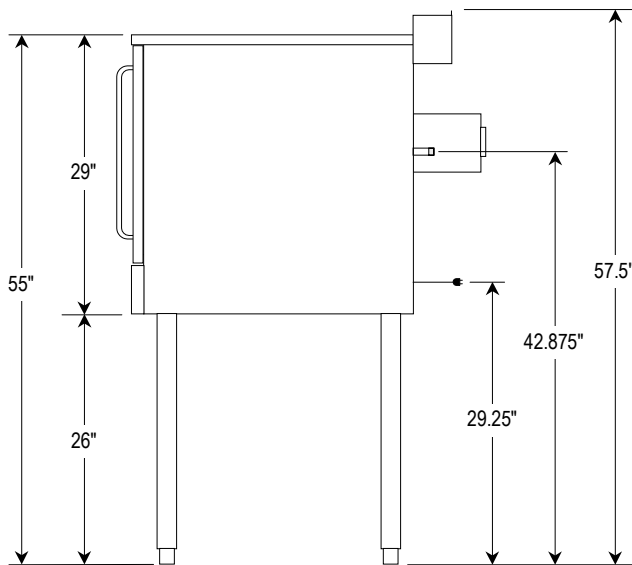
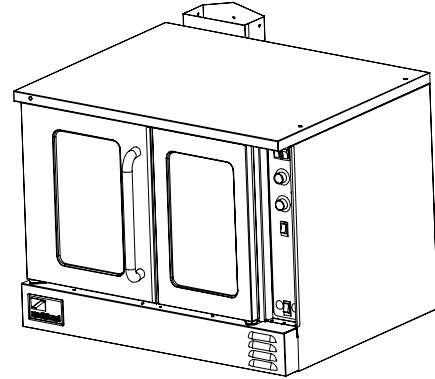

SIDE VIEW

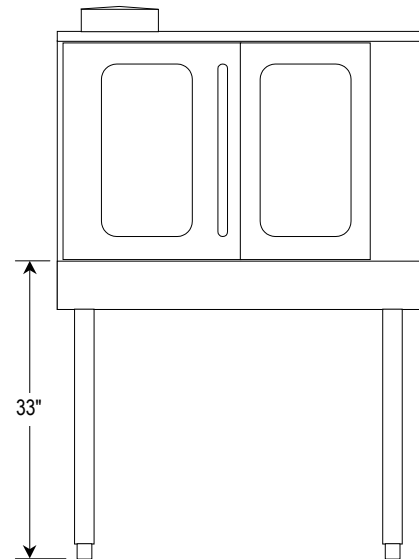

FRONT VIEW

Model Number	Depth Dimensions			Oven Interior			Rack Clearance		Shipping Crate				
	A	B	C	width	depth	height	width	depth	width	depth	height	volume	weight
GS/1... SLGS/1...	38.5"	30"	34.375"	29"	22.5"	20"	28.25"	22"	55"	45.5"	45"	65.17 cu. ft.	620 lbs.
GB1... SLGB/1...	45"	36.375"	40.75"	29"	28"	20"	28.25"	27.25"	55"	45.5"	45"	65.17 cu. ft.	690 lbs.

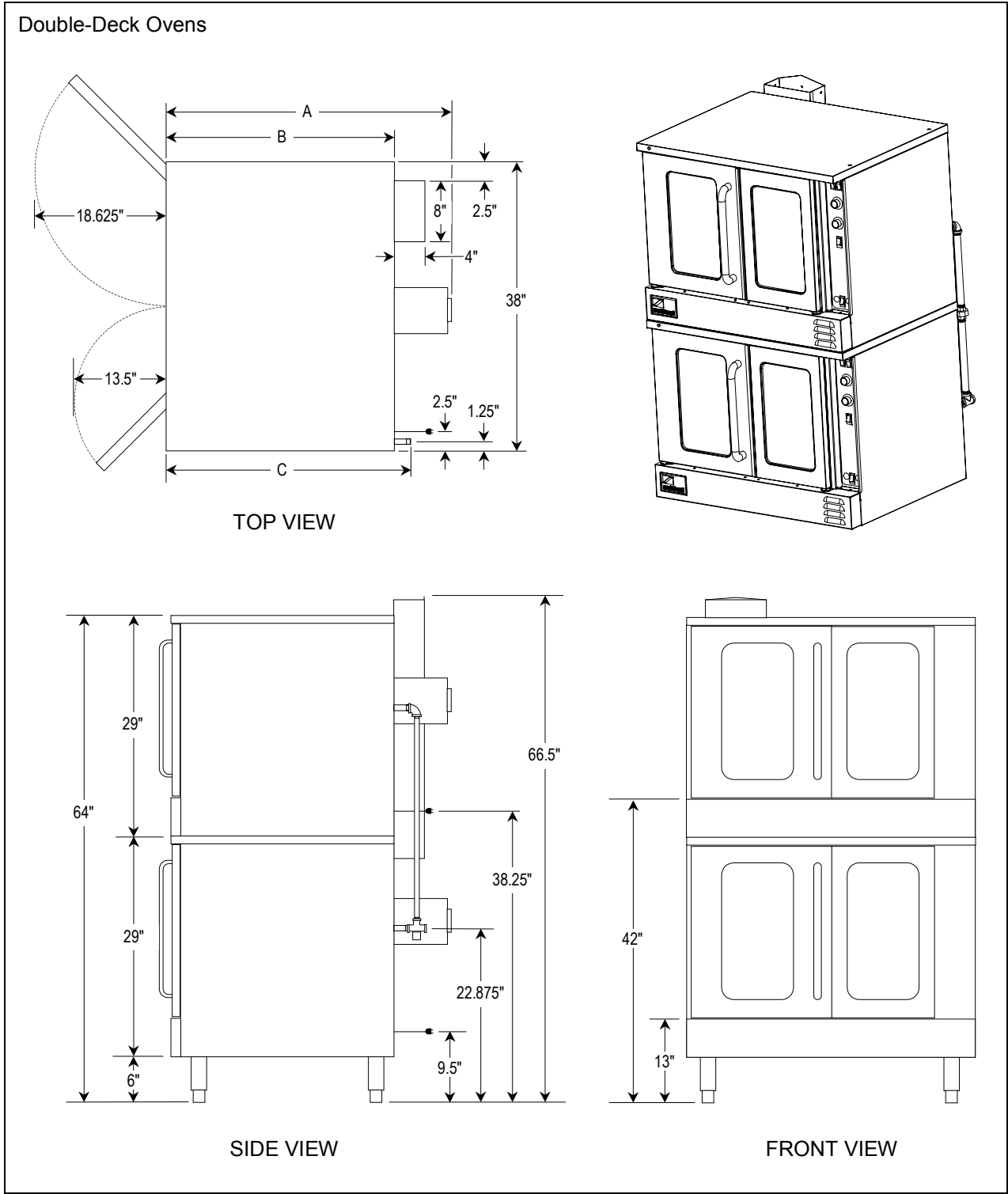
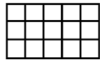

Model Number	Depth Dimensions			Oven Interior			Rack Clearance		Shipping Crate				
	A	B	C	width	depth	height	width	depth	width	depth	height	volume	weight
GS/2... SLGS/2...	38.75"	30"	34.375"	29"	22.5"	20"	28.25"	22"	55"	45.5"	81.5"	118 cu. ft.	1040 lbs.
GS/2... SLGS/2...	45.125"	36.375"	40.75"	29"	29"	20"	28.25"	27.25"	55"	45.5"	81.5"	118 cu. ft.	1080 lbs.



MINIMUM CLEARANCES

! WARNING

There must be adequate clearance between the left side of the ovens and combustible construction.

	Minimum Clearance from Combustible Construction	Minimum Clearance from Non-Combustible Construction
Back	0"	0"
Right Side	0"	0"
Left Side	2"	0"
Floor	0"	0"

Adequate clearance must be provided in the aisle to allow the doors to open sufficiently to permit the removal of the racks and for serviceability.

Although no clearance is required behind the motor on the rear of the oven, care must be taken to provide adequate air circulation to prevent the motor from overheating.

Do not locate the oven adjacent to any high heat or grease-producing piece of equipment, such as a range top, griddle, fryer, etc., that could allow radiant heat to raise the exterior temperature of the oven above 130°F (54°C). DO NOT MOUNT ABOVE OTHER COOKING EQUIPMENT.

VENTILATION

! WARNING

Improper ventilation can result in personal injury or death. Ventilation which fails to properly remove flue products can cause headaches, drowsiness, nausea, or could result in death.

All units must be installed in such a manner that the flow of combustion and ventilation air are not obstructed. Provisions for adequate air supply must be provided. Do not obstruct the front or rear of the unit as combustion air enters through these areas.

Be sure to inspect and clean the ventilation system according to the ventilation equipment manufacturer's instructions.

NOTICE

Proper ventilation is the owner's responsibility. Any problem due to improper ventilation will not be covered by the warranty.

If a ventilation canopy is used, it is recommended that a canopy extend 6" past the appliance and that the bottom edge be located 6'6" from the floor. Filters should be installed at an angle of 45° or more from the horizontal. This position prevents dripping grease and facilitates collecting the run-off grease in a drip pan, unusually installed with a filter.

If an exhaust fan is used, it should be installed at least 2" above the flue opening at the top of the unit. A strong exhaust fan tends to create a vacuum in the room and may interfere with burner performance. Fresh air openings approximately equal to the fan area will relieve such a vacuum. In case of unsatisfactory performance on any appliance, check the appliance with the exhaust fan in the "OFF" position. Do this only long enough to check equipment performance. Then turn the exhaust fan back on and let it run to remove any exhaust that may have accumulated during the test.

If the oven flue is connected directly to an outside flue, a CSA International design certified down draft diverter must be installed at the flue outlet of the oven and connected to the outside flue.



INSTALLATION

NOTICE

These installation procedures must be followed by qualified personnel or warranty will be void.

Local codes regarding installation vary greatly from one area to another. The National Fire Protection Association, Inc. states in its NFPA 96 latest edition that local codes are the "authority having jurisdiction" when it comes to installation requirements for equipment. Therefore, installations should comply with all local codes.

The installation must conform with local codes, or in the absence of local codes, with the *National Fuel Gas Code, ANSI Z223.1, Natural Gas Installation Code, CAN/CGA-B149.1*, or the *Propane Installation Code CAN/CGA-B149.2*, as applicable, including:

1. The appliance and its individual shutoff valve must be disconnected from the gas supply piping system during any pressure testing of that system at test pressures in excess of 1/2 psi (3.45 kPa).
2. The appliance must be isolated from the gas supply piping system by closing its individual manual shutoff valve during any pressure testing of the gas supply piping system at test pressures equal to or less than 1/2 psi (3.45 kPa).

Step 1: Unpacking

IMMEDIATELY INSPECT FOR SHIPPING DAMAGE

All containers should be examined for damage before and during unloading. The freight carrier has assumed responsibility for its safe transit and delivery. If damaged equipment is received, either apparent or concealed, a claim must be made with the delivering carrier.

Apparent damage or loss must be noted on the freight bill at the time of delivery. The freight bill must then be signed by the carrier representative (Driver). If the bill is not signed, the carrier may refuse the claim. The carrier can supply the necessary forms.

A request for inspection must be made to the carrier within 15 days if there is concealed damage or loss that is not apparent until after the equipment is uncrated. The carrier should arrange an inspection. Be certain to hold all contents plus all packing material.

1. Cut banding straps and remove packing material.
2. Cut banding strap holding oven to wooden skid.
3. If you are installing a single-deck SilverStar oven, go to Step 2a.
If you are installing a single-deck Marathoner Gold oven, go to Step 2b.
If you are installing a double-deck oven, go to Step 2c.



Step 2a: Installation of Legs on Single-Deck, SilverStar Models

1. Raise oven sufficiently to allow clearance for the legs to be attached. Use of a lift truck or other mechanical lifting means is recommended. For safety, "shore up" and support the oven with an adequate blocking arrangement strong enough to support the load. (If it is absolutely necessary to rest the oven on its side, rest it on its left side or back side. Take care to protect the finish on the left side, and to prevent the weight from resting on the motor on the back.)
2. Attach the legs to the bottom corners of the oven using the provided machine screws, flat washers, and lock washers. Each leg is secured by five screws. The mounting holes are pre-drilled and threaded.
3. Screw into the bottom of each leg either an adjustable foot or a caster (depending on which option was ordered). If attaching casters, the two casters with brakes should be attached to the front legs.
4. Lower the oven gently onto a level surface. Never drop or allow the oven to fall.
5. Use a level to make sure that the oven is level. The adjustable feet can be screwed in or out to lower or raise each corner of the oven.
6. If casters were installed, go to Installation Step 3 on page 13, otherwise go to Step 4 on page 14.

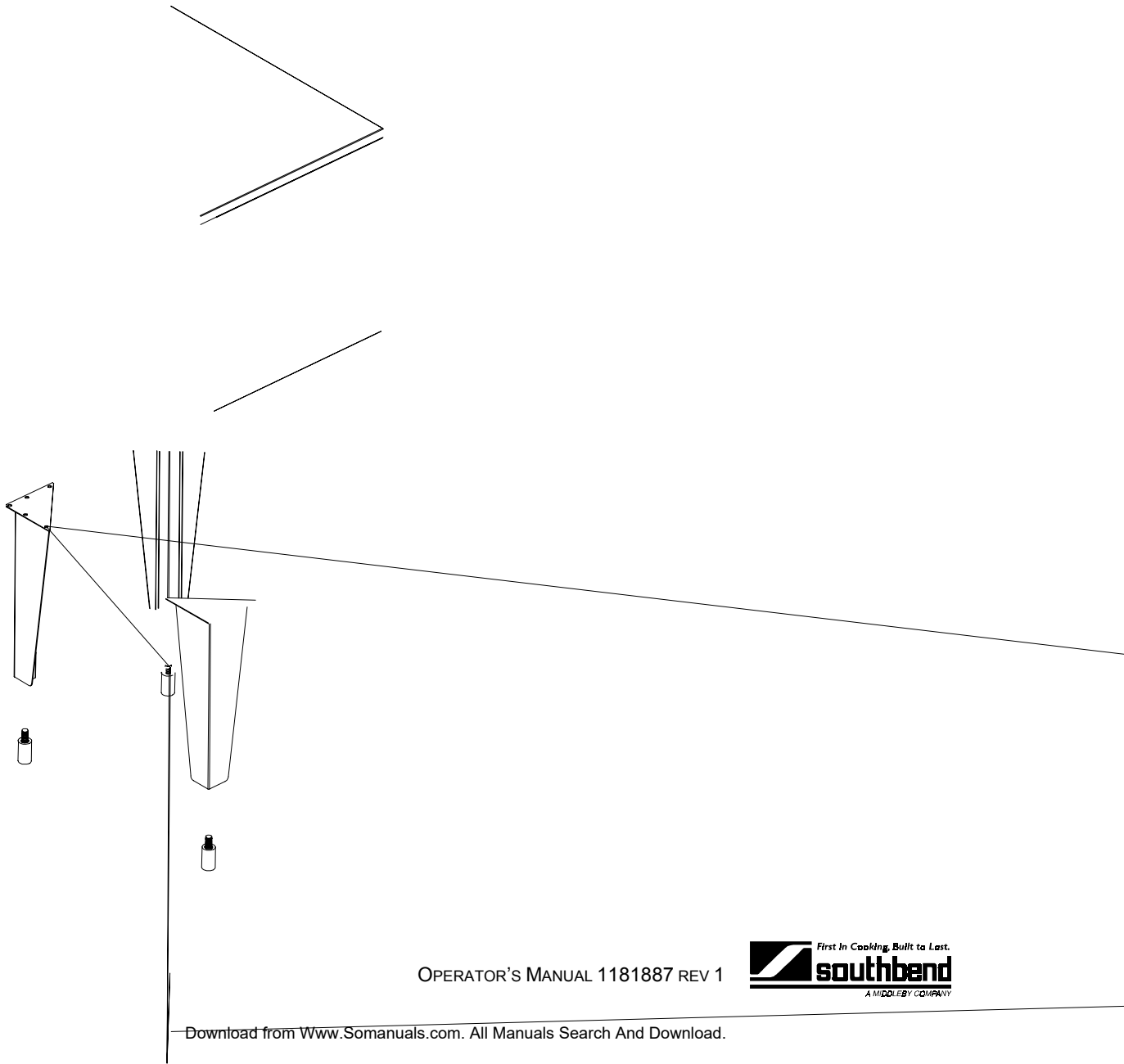



Step 2b: Installation of Legs on Single-Deck, Marathoner Gold Models

1. Raise oven sufficiently to allow clearance for the legs to be attached. Use of a lift truck or other mechanical lifting means is recommended. For safety, "shore up" and support the oven with an adequate blocking arrangement strong enough to support the load. (If it is absolutely necessary to rest the oven on its side, rest it on its left side or back side. Take care to protect the finish on the left side, and to prevent the weight from resting on the motor on the back.)
2. Attach the legs to the bottom corners of the oven using the provided machine screws, flat washers, and lock washers. Each leg is secured by four screws. The mounting holes are pre-drilled and threaded.
3. Screw into the bottom of each leg either an adjustable foot or a caster (depending on which option was ordered). If attaching casters, the two casters with brakes should be attached to the front legs.
4. Lower the oven gently onto a level surface. Never drop or allow the oven to fall.
5. Use a level to make sure that the oven is level. The adjustable feet can be screwed in or out to lower or raise each corner of the oven.
6. If casters were installed, go to Installation Step 3 on page 13, otherwise go to Step 4 on page 14.

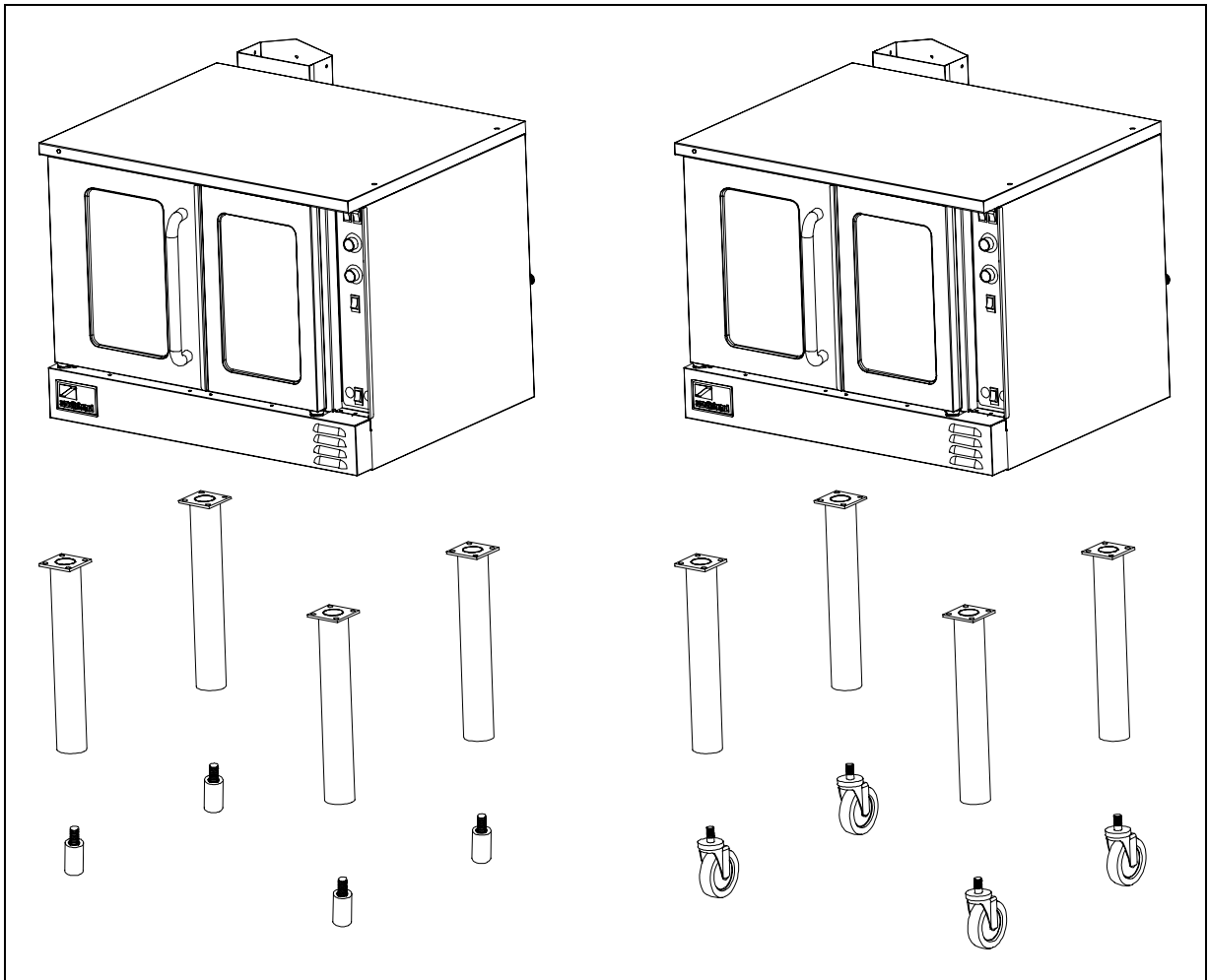



Step 2c: Installation of Legs on Double-Deck Ovens

Double-deck oven can be shipped either already bolted together, or as two separate ovens to be bolted together after delivery. In either case, the oven that is (or will be) the lower oven will have leg pads already bolted to the bottom corners of the oven. Do the following:

1. Raise oven sufficiently to allow clearance for the legs to be attached. Use of a lift truck or other mechanical lifting means is recommended. For safety, "shore up" and support the oven with an adequate blocking arrangement strong enough to support the load. (If it is absolutely necessary to rest the oven on its side, rest it on its left side or back side. Take care to protect the finish on the left side, and to prevent the weight from resting on the motor on the back.)
2. Screw into the center of each leg pad either an adjustable leg or a caster (depending on which option was ordered). If attaching casters, the two casters with brakes should be attached to the front leg pads.
3. Lower the oven gently onto a level surface. Never drop or allow the oven to fall.
4. Use a level to make sure that the oven is level. The adjustable legs can be screwed in or out to lower or raise each corner of the oven.
5. If casters were installed, go to Installation Step 3 on page 13, otherwise go to Step 4 on page 14.

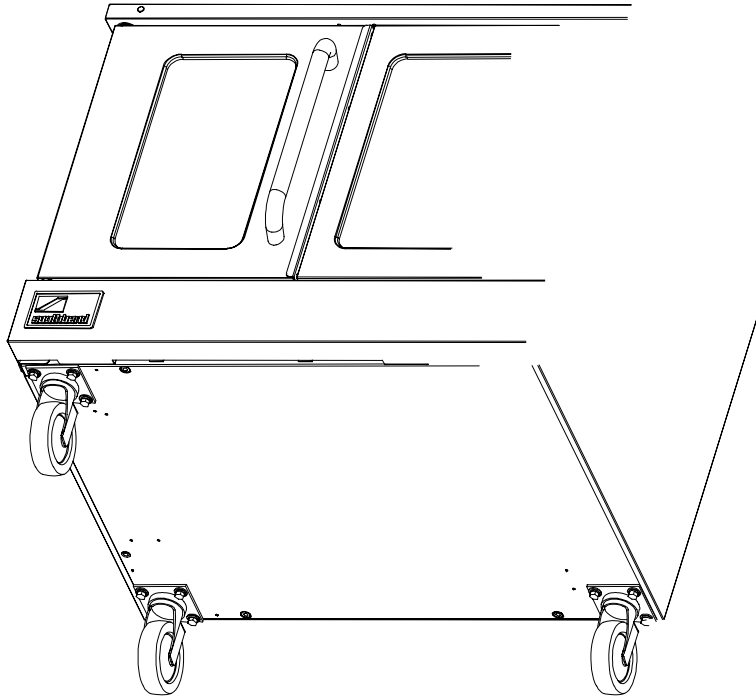



Step 3: Installation of Restraint (Only for Ovens with Casters)

NOTICE

For an appliance equipped with casters, (1) the installation shall be made with a connector that complies with the *Standard for Connectors for Movable Gas Appliances, ANSI Z21.69* or *Connectors for Moveable Gas Appliances, CAN/CGA-6.16*, and a quick-disconnect device that complies with the *Standard for Quick-Disconnect Devices for Use With Gas Fuel, ANSI Z21.41*, or *Quick Disconnect Devices for Use with Gas Fuel, CAN1-6.9*, (2) adequate means must be provided to limit the movement of the appliance without depending on the connector and the quick-disconnect device or its associated piping to limit the appliance movement and (3) the restraining means should be attached to a frame member on the back of the unit.

! WARNING

To avoid accidental gas disconnection and potential explosion:

If disconnection of this restraint is necessary to move the appliance for cleaning, etc., reconnect it when the appliance is moved to its originally installed position.

1. Secure the restraining-device bracket (item "B" in the following illustration) to a wall stud located as close as possible to the appliance connector inlet and outlet connections. Use four #12 screws (items "C") and plastic anchors (items "A") if necessary.

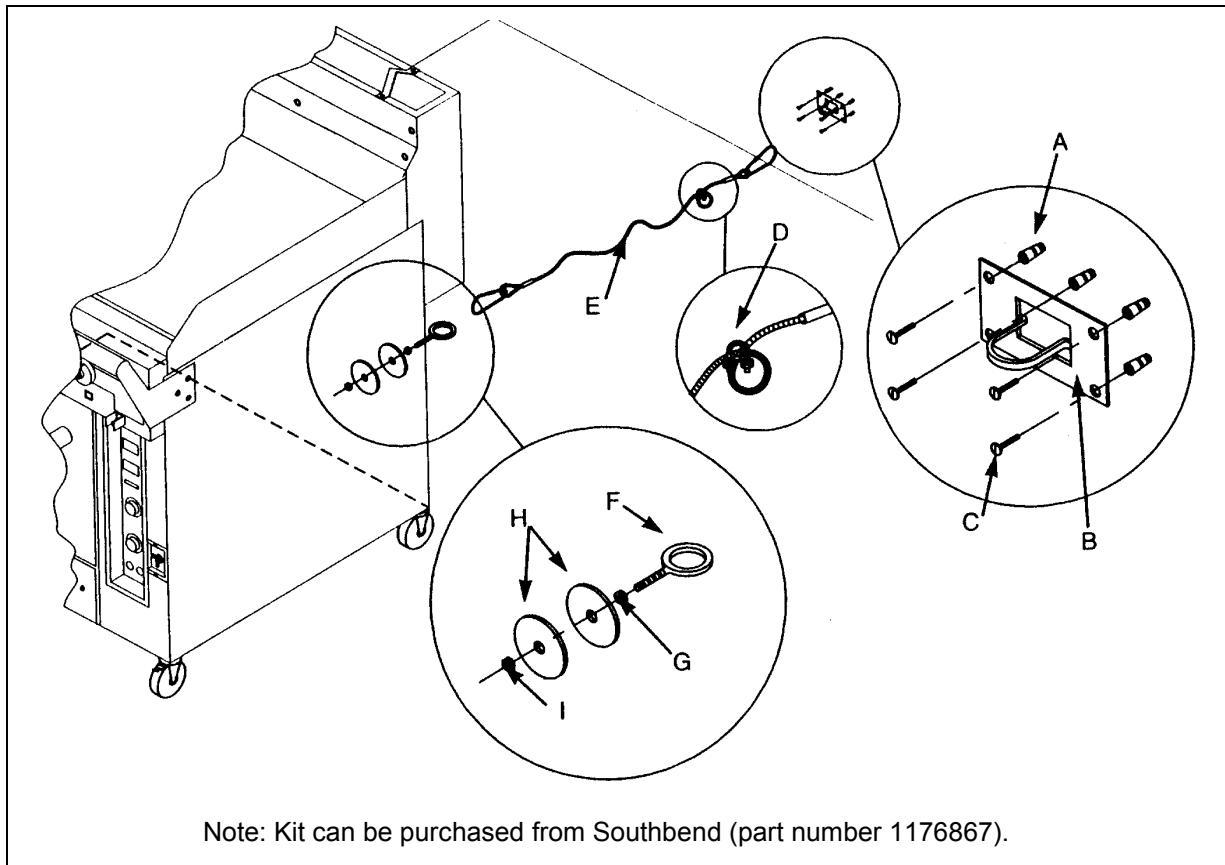



2. Install eye-bolt (item "F") to a frame member on the rear of the equipment. After checking carefully behind the frame member for adequate clearance, drill a 1/4" hole through the frame member.
3. Thread hex nut (item "G") and slide the washer (item "H") onto the eye-bolt. Insert the eye-bolt through the 1/4" drilled hole and secure with a washer (item "H") and nylon lock nut (item "I").
4. Using the spring-loaded snap hooks, attach the restraining device to the bracket and the eye-bolt.
5. Using the cable clamp (item "D"), adjust the restraining device extended length to prevent over-bending or kinking of the appliance connector.

For units not equipped with flame safety devices, be sure all valves are turned off prior to disconnecting. After reconnecting, be sure that the oven is switched OFF.

Step 4: Stack Double-Deck Oven (if necessary)

Double-deck ovens can be shipped already assembled, but can instead be shipped as two single-deck ovens to be stacked in the field. Also, ovens that were originally ordered as single ovens can be stacked in the field (additional parts are required). This installation step describes the procedure for stacking two single-deck ovens to form a double-deck oven.

1. Uncrate the two ovens. Identify the oven that will be the lower oven (it will be the oven with leg pads attached to the bottom corners). Attach the legs (or casters) to the lower oven as described in Step 2c on page 12.
2. If the oven that will be the top oven was NOT ordered as part of a double-deck oven, remove the four leg pads from the bottom of the top oven.
3. Locate and remove the four screws that secure the lower front panel (items "A" in the drawing below). Lift up the panel and pull it forward to remove it, then set it aside.
4. Locate and remove the five screws that secure the right side panel to the oven (items "B" in the drawing below). Remove the right side panel and insulation and set them aside.

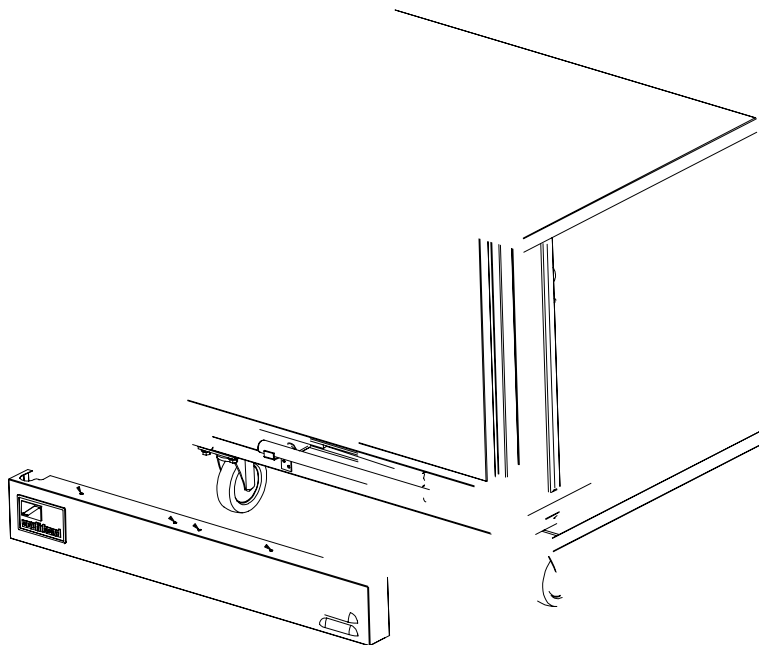



5. Lift the top oven and position it on top of the lower oven, as shown in the drawing below.

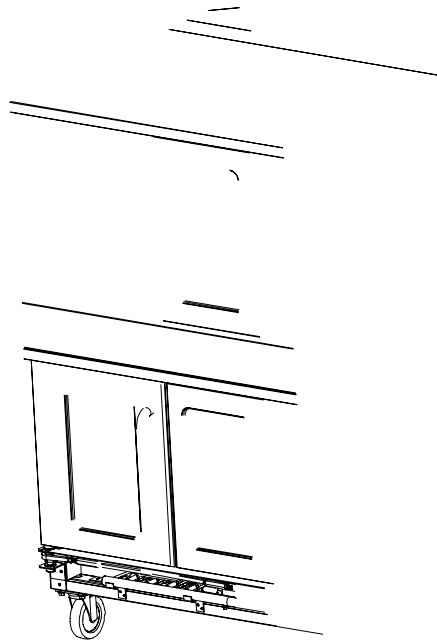

INSTALLATION



INSTALLATION

MARATHONER GOLD & SILVERSTAR GAS CONVECTION OVENS

INSTALLATION

7. Insert two bolts (items "A" in the following diagram) up through the top of the lower oven and screw them into the threaded holes in the bottom of the top oven. Tighten these bolts and the screws that you did not tighten in the previous step.

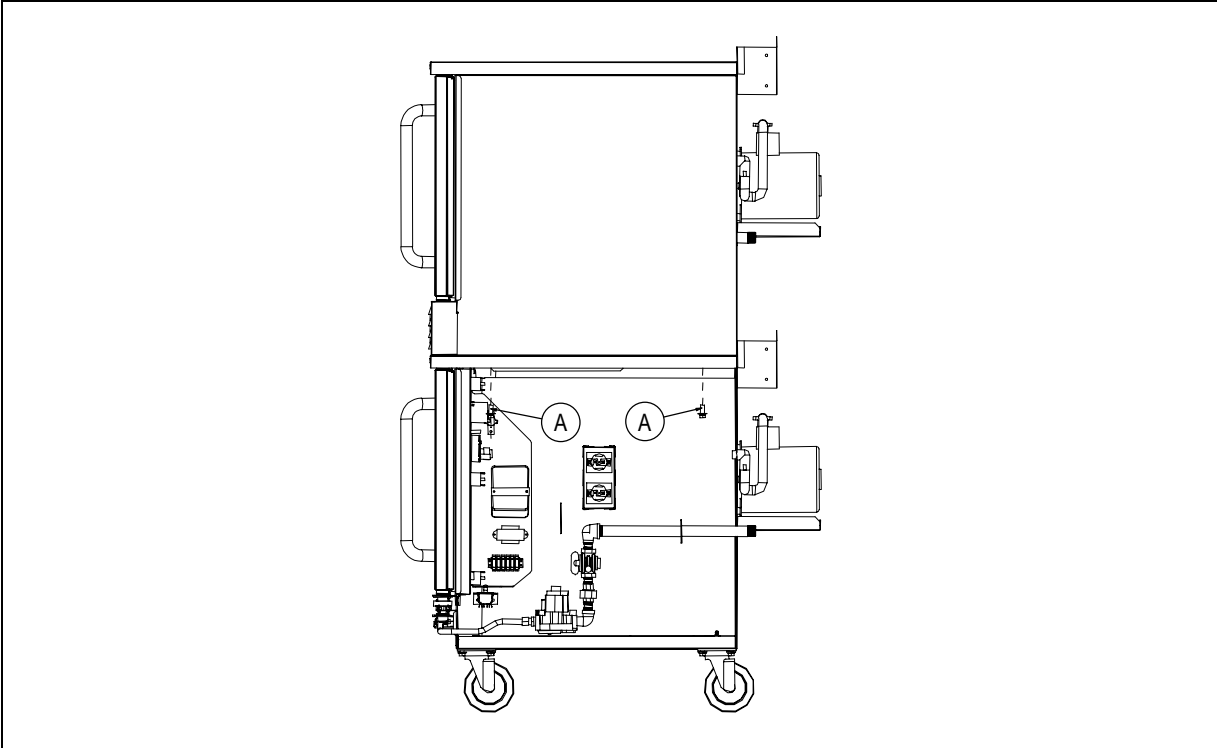

8. Assemble the gas piping shown in the following drawing. Be sure to check all connections for leaks once the oven has been installed.

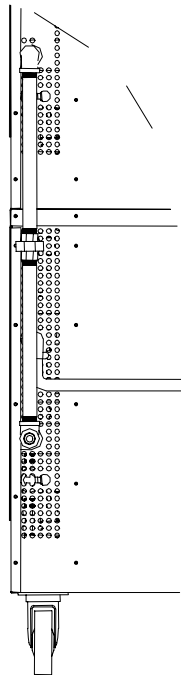





Step 5: Install Down Draft Diverter (if applicable)

NOTICE

Installation must use approved CSA International down draft diverter supplied by Southbend.

If the oven flue is to be connected directly to an external vent, a down draft diverter must be installed. The installation of ventilation pipes through walls and roofs must conform to all local codes. To install the down draft diverter, do the following:

1. Slip the down draft diverter over the top of the flue located at the top left rear corner of the oven (see drawing below). Allow the diverter to slide down as far as it will go.
2. Using a 9/64" or 5/32" drill bit, drill eight holes through the flue box using the pre-drilled holes in the diverter as a guide.
3. Secure the diverter to the flue box using the #10 x 1/2 sheet metal screws shipped with the diverter.

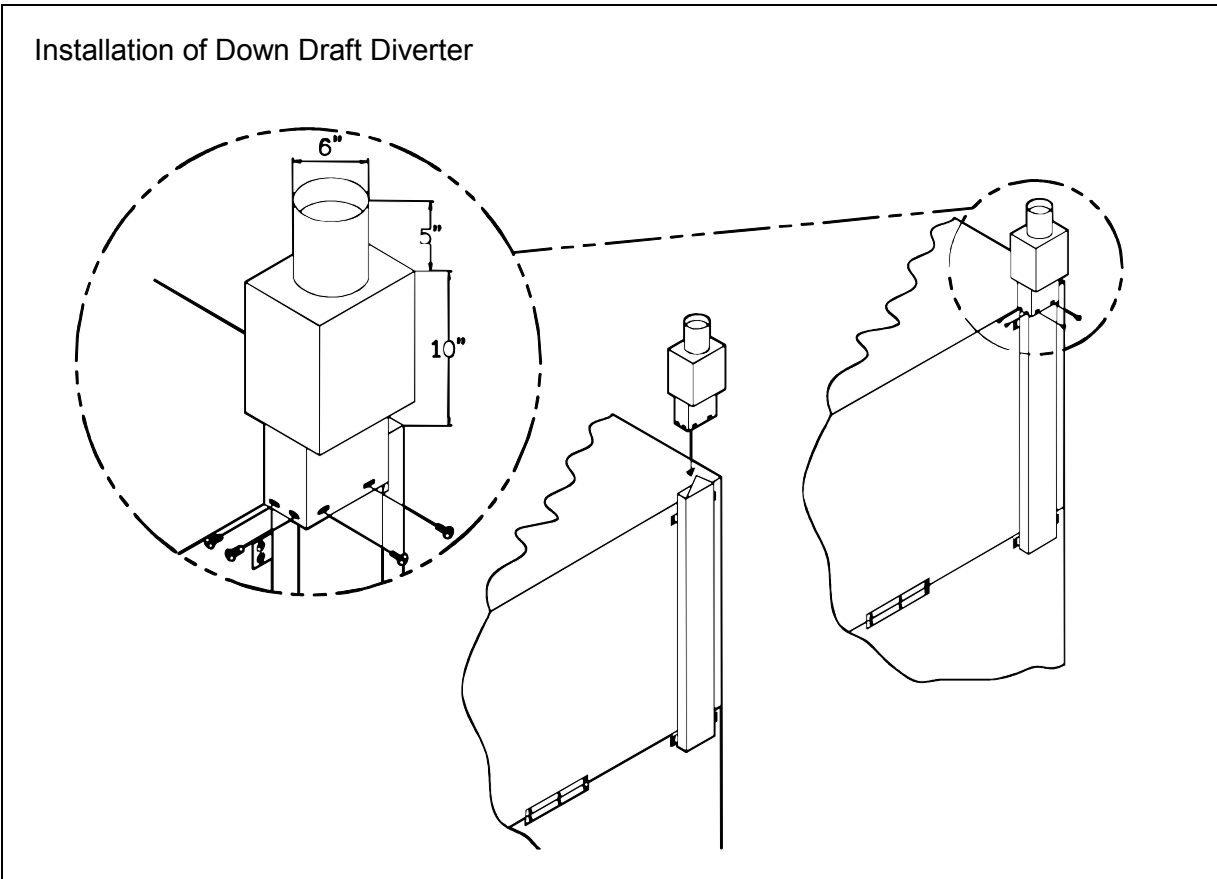



Step 6: Installation of Optional Open Rack Storage

An option for single-deck Marathoner Gold ovens is to have open rack storage below the oven. The following describes how to assemble this option. All holes are pre-drilled for the screws provided.

1. Attach the legs to the oven as described in installation Step 2b on page 11.
2. Attach the two frame hangers (items "A" in the following drawing). The flanged side of each rack hanger must be on the side of the hanger closest to the edge of the oven.

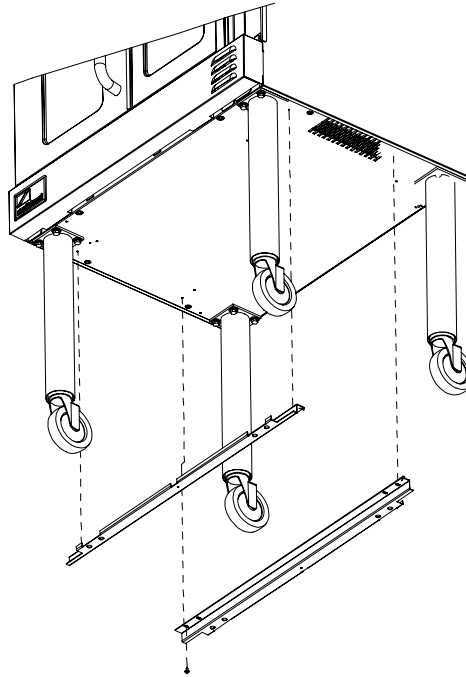



INSTALLATION

MARATHONER GOLD & SILVERSTAR GAS CONVECTION OVENS

4. Attach either the shelf or the two channel frames (depending on which option was ordered) as shown in the drawing below. Use the screws and four side rack clips provided to secure the shelf or channel frames to the rack guides.

INSTALLATION

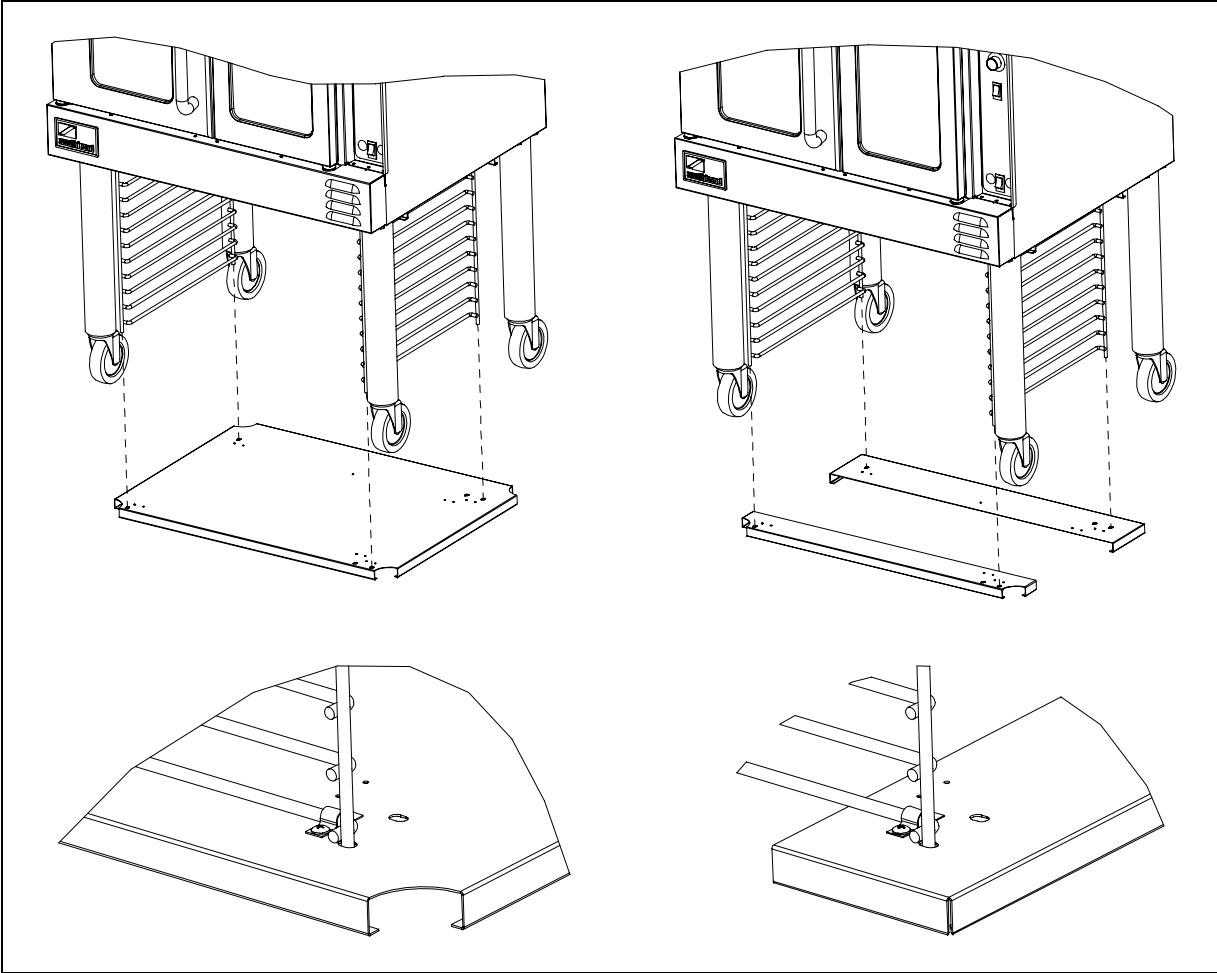

5. Attach the rack stop using two screws. Attach the top of the rack stop to the rear frame hanger, and the bottom of the rack stop to the bottom shelf or the rear channel frame, as shown in the following drawing.

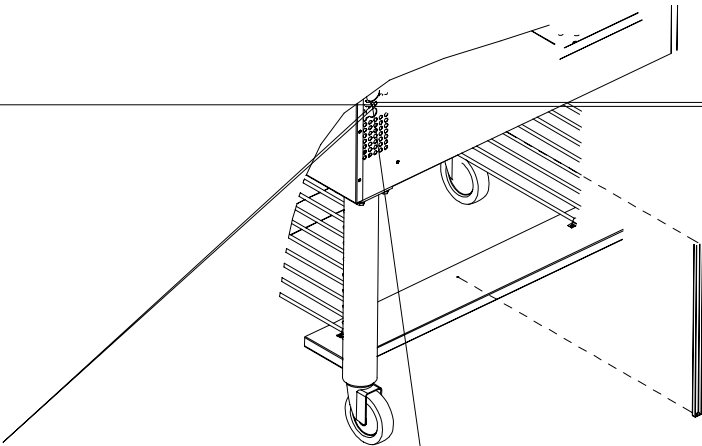





Step 8: Connect Gas Supply

NOTICE

The installation must conform with local codes, or in the absence of local codes, with the *National Fuel Gas Code, ANSI Z223.1, Natural Gas Installation Code, CAN/CGA-B149.1*, or the *Propane Installation Code CAN/CGA-B149.2*, as applicable, including:

1. The appliance and its individual shutoff valve must be disconnected from the gas supply piping system during any pressure testing of that system at test pressures in excess of 1/2 psi (3.45 kPa).
2. The appliance must be isolated from the gas supply piping system by closing its individual manual shutoff valve during any pressure testing of the gas supply piping system at test pressures equal to or less than 1/2 psi (3.45 kPa).

A 3/4" NPT line is provided at the rear for the gas connection.

If this equipment is being installed at over 2,000 feet altitude and that information was not specified when ordered, contact the appropriate authorized Southbend Service Representative or the Southbend Service Department. Failure to install with proper orifice sizing will result in poor performance and may void the warranty.

The serial plate is located inside the front lower panel. It indicates the type of gas the unit is equipped to burn. All Southbend equipment is adjusted at the factory. Check type of gas on serial plate.

These models are design-certified for operation on natural or propane gases. For natural gas, the regulator is set to deliver a 4.5" W.C. pressure to the manifold. For propane gas, it is set to deliver 11" W.C.

This appliance should be connected **ONLY** to the type of gas for which it is equipped. The inlet pressure before the regulator should be 7-10" W.C. for natural gas or 11-14" W.C. for LP gas.

An adequate gas supply is imperative. Undersized or low pressure lines will restrict the volume of gas required for satisfactory performance. Fluctuations of more than 25% on natural gas or 10% on propane gas will create problems and affect burner operating characteristics.

An adequate gas supply line to the unit should be no smaller than the I.D. of the pipe from the unit to which it is connected.

Purge the supply line to clean out dust, dirt, or other foreign matter before connecting the line to the unit.

CAUTION

ALL PIPE JOINTS AND CONNECTIONS MUST BE TESTED THOROUGHLY FOR GAS LEAKS. USE ONLY SOAPY WATER FOR TESTING ON ALL GASES. NEVER USE AN OPEN FLAME TO CHECK FOR GAS LEAKS. ALL CONNECTIONS MUST BE CHECKED FOR LEAKS AFTER THE UNIT HAS BEEN PUT INTO OPERATION. TEST PRESSURE SHOULD NOT EXCEED 1/4" W.C.

Step 9: Check the Installation

1. Check that all screws and bolts are tightened.
2. Move the oven into the position at which it will be operated.
3. Check that the oven is level. If not, adjust the legs.
4. Check that the appropriate clearances are satisfied (see page 8).



OPERATION

 **DANGER**
EXPLOSION HAZARD

In the event a gas odor is detected, shut down equipment at the main shut off valve. Immediately call the emergency phone number of your gas supplier.

 **CAUTION**

To eliminate gas build up which could result in an explosion, in the event of main burner ignition failure a five minute purge period must be observed prior to re-establishing ignition source.

NOTICE

For an appliance equipped with a convection oven, no attempt should be made to operate oven during a power failure.

OPERATION

LIGHTING, RELIGHTING, AND SHUTDOWN INSTRUCTIONS

To light the oven, just switch the power switch at the top left corner of the control panel to the “ON” position. (The oven is equipped with a direct hot surface ignition system. There is no pilot to light.)

If the burners fail to ignite within four seconds, the oven will automatically shut off the gas, wait five minutes to allow the gas that was released to dissipate, and try to light the burners again. If the burners still fail to ignite after three such attempts, the oven will stop trying, even though the power switch is in the “ON” position. To continue to attempt to light the burners, turn the power switch “OFF” and then “ON” again.

To shutdown the oven, switch the power switch to the “OFF” position. For a complete shutdown, also open the control panel and turn the manual shut-off valve to the “OFF” position.

OPERATING THE CONTROLS

A convection oven is a different type of oven that offers many features and advantages to the food service operation. The additional capabilities and features of the oven require some learning. However, the operation of the oven is not difficult to understand or control once you have some practice.

The oven will have one of the four types of control panels:

- Models with **Standard Controls** are the most similar to a standard (non-convection) oven. Instructions for operating this type of oven begin on page 24.
- Models with **Cycle/Cook and Hold Controls** enable you to have the oven automatically enter a “hold mode” after a timed cooking period. Instructions for operating this type of oven begin on page 26.
- Models with **Programmable Controls** enable you to have the oven change temperature and other settings while cooking, then optionally enter a “hold mode.” You can record up to five “cook programs” which can then be re-used later. Instructions for operating this type of oven begin on page 29.
- Models with **Rack Timer Controls** provide five separate timers that independently time the cooking of food on each rack of the oven. The oven will tell you which rack will finish cooking next, and how much time remains. Instructions for operating this type of oven begin on page 32.



Control Panel of STANDARD Models

OPERATION

Power Switch

Switch ON to use the oven, switch OFF when done using the oven.

Cook Timer

Turn knob to set a time duration. An alarm will sound when the timer runs out. The timer is a reminder to the user; **the timer does not control the oven.**

Cook Temperature Control

Turn knob to select desired cooking temperature. The Heat On indicator will go out when the oven reaches the set temperature, and will cycle on and off as the burners operate to maintain the set cooking temperature.

Oven Interior Light Switch

On ovens equipped with an oven interior light, press to turn on the light. The light remains on for as long as the switch is held.

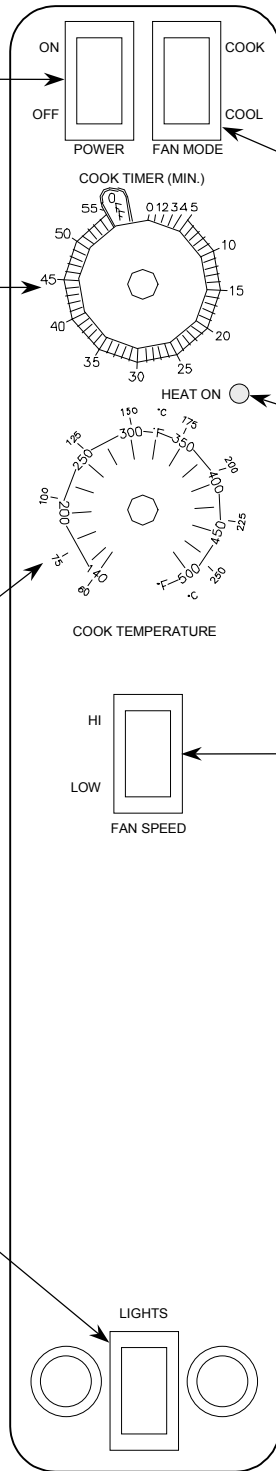

Fan Mode

In COOK mode, the fan runs continuously except when the doors are open. The fan does NOT cycle with the operation of the burners. In COOL mode, the fan runs continuously even if the doors are open. Since the burners will not operate if the oven doors are open, to rapidly cool the oven after cooking is completed, open the doors and switch the fan mode to COOL.

Heat-On Indicator

Indicator is lit when the burners are operating.

Fan Speed

Use to select fan speed (HI or LOW). The appropriate speed is determined by the type of food being cooked.



Operation of STANDARD Models

Models with Standard Controls operate much like a standard oven: you turn the oven ON and select a cooking temperature. Two additional controls are used to control the fan (as described below).

The timer is a reminder to you of when to remove food from the oven. **The timer does NOT control the temperature of the oven.**

To cook, do the following:

1. Turn the oven ON using the Power Switch at the top of the control panel.
2. Select the desired fan speed using the Fan Speed switch. The appropriate fan speed (HI or LOW) depends on the type of food being cooked.
3. Switch the Fan Mode switch to COOK. The fan will run continuously when the oven doors are closed (the fan does not cycle on and off with the burners). (If this switch is set to COOL the only difference is that the fan will continue to run when the oven doors are open.)
4. Set the cooking temperature by turning the Cook Temperature Control until the indicator mark on the knob is pointed to the desired cooking temperature. The Heat On indicator will light when the burners are on, and will remain on while the oven preheats.
5. Wait until the Heat On indicator has come on and gone out three times. At that time the oven will have reached the set cooking temperature.
6. Open the oven doors, load the product into the oven, and close the doors.
7. You can use the Cook Timer as a reminder of when to remove the load from the oven. If so desired, turn the Cook Timer knob until the indicator mark points to the desired cooking time (up to 55 minutes). The timer knob will rotate counterclockwise as the timer runs down, indicating how much time remains. You can turn the knob while cooking to increase or decrease the remaining time. When the timer runs out, a buzzer will sound for a short time, then turn itself off. (To immediately silence the buzzer, turn the Cook Timer knob to the OFF position.) The timer is a reminder to you; **the timer does not control the oven.**

If you open the oven doors, the burners and fan will shut off until the doors are closed. However, the timer will continue running even if the doors are open.

For ovens that are equipped with an oven interior light, to turn on the light press and hold the switch located at the bottom of the control panel.

8. When the load has finished cooking, you can rapidly cool the load by opening the oven doors (which will shut off the burners) and switching the Fan Mode to COOL (which will cause the fan to run even though the doors are open). For the most rapid cooling, also switch the Fan Speed switch to HI.
9. When you are done cooking, turn the Cook Temperature control to the lowest setting (fully counterclockwise) and switch the Power Switch to OFF.



Control Panel of CYCLE/COOK and HOLD Models

OPERATION

Power Switch

Switch ON to use the oven, switch OFF when done using the oven.

Time Display

Displays time setting. Indicator lights indicate whether the numbers shown represent hours-and-minutes or minutes-and-seconds.

Temperature Display

Displays cook-temperature setting.

Heat-On Indicator

Indicator is lit when the burners are operating.

Hold Mode Indicator

Lights when Hold mode has been enabled.

Hold Mode Button

Press to toggle Hold Mode on or off. To set the Hold temperature, press and hold this button while adjusting the temperature.

Cook Start/Stop Button

Press to start a timed cook period whose duration is shown in the TIME window. During a timed cook period, the TIME window displays the remaining time. To stop cooking, press this button again.

Oven Interior Light Switch

On ovens equipped with an oven interior light, press to turn on the light. The light remains on for as long as the switch is held.

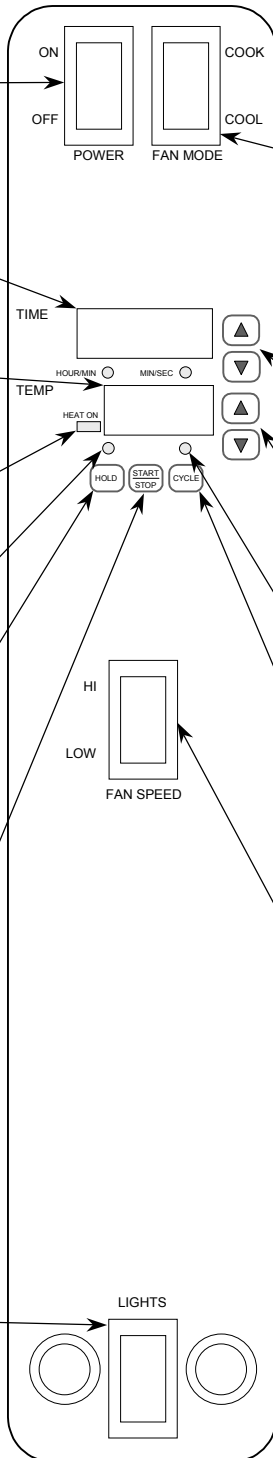

Fan Mode

In COOK mode, the fan runs except when the doors are open. The fan does NOT cycle with the operation of the burners. In COOL mode, the fan runs continuously even if the doors are open. Since the burners will not operate if the oven doors are open, to rapidly cool the oven after cooking is completed, open the doors and switch the fan mode to COOL.

Timer Adjustment Buttons

Press the up-arrow button to increase the time setting; press the down-arrow button to decrease the time setting.

Temperature Adjustment Buttons

Press the up-arrow button to increase the temperature setting; press the down-arrow button to decrease the temperature setting.

Fan Cycle Indicator

When on continuously the fan will run continuously. When flashing, fan will cycle on-and-off.

Fan Cycle Button

Press to select whether the fan runs continuously, or cycles on and off.

Fan Speed Switch

Use to select fan speed (HI or LOW). The appropriate speed is determined by the type of food being cooked.



Operation of CYCLE/COOK and HOLD Models

CYCLE/COOK and HOLD models have electronic controls that enable the oven to cook food at a specified cook-temperature for a specified time period, then enter an optional Hold Mode during which the oven maintains a specified hold-temperature for an indefinite period of time.

Whenever the power switch is on, the oven will be in one of two modes. In **Cook Mode**, the oven maintains the specified cook temperature and the fan runs continuously, unless the Cycle option is enabled, in which case the fan cycles (on for 30 seconds, then off for 30 seconds). In **Hold Mode**, the oven maintains the specified hold-temperature and the fan runs only when the burners are on. (However, whenever the Fan Mode switch is in the COOL position, the fan will run continuously.)

To cook, do the following:

1. Turn the oven ON using the Power Switch at the top of the control panel. The oven will be in Cook Mode, and will begin to heat to the temperature displayed in the temperature display window.
2. Set the desired cook-temperature (from 150°F to 500°F) by pressing the up-arrow and/or down-arrow buttons to the right of the temperature display window. The temperature display will flash while the oven preheats. The Heat On indicator will light when the burners are on. To view the actual oven temperature at any time, press the up-arrow and down-arrow buttons simultaneously.
3. Switch the Fan Mode switch to the COOK position (if it is not already in that position). The fan will run when the oven doors are closed (the fan does not cycle on and off with the burners). (If this switch is set to COOL the only difference is that the fan will continue to run when the oven doors are open.)
4. Select whether you want the fan to cycle during cooking by pressing the Cycle button. If the Cycle indicator light is on continuously, the fan will run continuously. If instead the Cycle indicator light is flashing, the fan will cycle on for 30 seconds and then off for 30 seconds while cooking. Fan cycling is used for delicate products such as meringues and muffins which need to set, and is usually combined with the LOW fan speed (selected in the next step).
5. Select the desired fan speed by pressing the Fan Speed switch. The appropriate fan speed (HI or LOW) depends on the type of food being cooked.
6. Select the desired cooking time by pressing the up-arrow and/or down-arrow buttons to the right of the time display window. Holding down a button will speed-up the rate at which the displayed value changes. Lights under the displayed time indicate if the displayed time is in minutes-and-seconds or in hours-and-minutes. The time setting will not start counting down until you tell the oven to start cooking (in Step 9).
7. If you want the oven to enter a lower-temperature Hold Mode after a timed cook period, press and hold down the Hold button. The temperature display will now show the oven temperature (140°F to 200°F) desired during the hold mode. You can change the desired holding temperature using the up-arrow and down-arrow buttons to the right of the temperature display window (while holding down the Hold button). If you want the oven to enter Hold Mode after the cook time, be sure that the Hold Mode Indicator is lit (if it is not, press and release the Hold button so that it becomes lit). Note that when Hold Mode starts the actual oven temperature will not immediately drop to the holding temperature since it takes time for the oven interior and the load itself to cool.

CAUTION

Care should be exercised in holding products over extended periods of time or at very low holding temperatures, due to possible bacteria growth. A competent authority on food bacteria growth should be consulted if there is doubt regarding safe holding times and temperatures.

8. Wait until the oven has reached cooking temperature (when it does, the temperature display will stop flashing and the oven will “beep” once).
9. Open the oven doors and insert a load into the oven. Close the doors and press the Start/Stop button. The oven will enter Cook Mode and the time display will start to count down the remaining cook time.



If you open the oven doors, the fan and burners will temporarily shut off, and the time display will pause until the oven doors are closed again.

For ovens that are equipped with an oven interior light, to turn on the light press and hold the switch located at the bottom of the control panel.

During the cook time you can start or stop having the fan cycle on-and-off by pressing the Cycle button.

If necessary, you can adjust the remaining cooking time and/or oven temperature using the corresponding up-arrow and down-arrow buttons. You can also disable or enable Hold Mode.

To cancel a timed-cook, press the Start/Stop button.

10. What happens when the cook time runs out depends on whether Hold Mode is enabled.
- If Hold Mode IS NOT enabled, the oven will start “beeping” and the time display will flash “:00”. Press the Start/Stop button to silence the alarm and the oven will return to Cook Mode. Promptly remove the load from the oven OR open and leave open the oven doors. **If the oven doors are shut, the oven will maintain the set cook temperature even though the timer has run out.** To rapidly cool down the load, open the doors, switch the Fan Mode switch to COOL, and switch the Fan Speed switch to HI.
 - If Hold Mode IS enabled, the oven will beep 3 times to alert you that the cook time has completed. The time display will start counting up to indicate how long the load has been in Hold Mode (up to 99 hours). The temperature display will change to show the holding temperature (set in Step 7) and the burners will remain off while the oven gradually cools to the holding temperature. With the doors closed, the oven will maintain the set holding temperature until you press the Start/Stop button (usually after removing the load). Pressing the Start/Stop button returns the oven to Cook Mode, and the oven will then heat up to the specified cook temperature in anticipation of the next load to be cooked.
11. When you are done cooking, switch the Power Switch to OFF.



Control Panel of PROGRAMMABLE Models



OPERATION



Operation of Models with PROGRAMMABLE Controls

Models with Programmable Controls can follow a recorded sequence of timed cooking periods, with an option of the last period being an indefinite hold time. Each time period begins with an “event” that specifies what conditions will be maintained during the period that follows.

To cook WITHOUT using a recorded cook program, do the following:

1. Turn the oven ON using the Power Switch at the top of the control panel.
2. Set the cooking temperature by turning the Temperature Knob. The setting appears in the top right corner of the control panel display. The displayed temperature will flash while the oven preheats.
3. Select the desired fan speed during cooking by pressing the Cook Hi/Lo Fan button. The setting (COOK for high fan speed or ROAST for low fan speed) appears in the control panel display just below the temperature setting. The appropriate fan speed depends on the type of food being cooked.
4. Select the desired fan mode by pressing the Fan Cont/Cyc button. The setting appears in the control panel display just below the fan speed setting. In continuous mode (CONT), the fan will run when the power switch is ON and the doors are closed. In cycle mode (CYCLE), the fan will run only when the doors are closed and the burners are operating.
5. Turn the Time knob until the desired cooking time appears on the control panel display.
6. If you want the oven to enter Hold Mode after the timed cook period, press the Hold button. The Hold indicator (the word “HOLD” in the control panel window) will appear. Turn the Temperature knob until the desired holding temperature is displayed. Select a fan mode for the hold time by pressing the Fan Cont/Cyc button (as you did for the cook time in Step 4). The fan speed is always low during Hold Mode. Note that when Hold Mode starts the actual oven temperature will not immediately drop to the holding temperature since it takes time for the oven interior and the load itself to cool.

CAUTION

Care should be exercised in holding products over extended periods of time or at very low holding temperatures, due to possible bacteria growth. A competent authority on food bacteria growth should be consulted if there is doubt regarding safe holding times and temperatures.

7. Wait until the oven has reached cooking temperature (when it does, the temperature display will stop flashing and the oven will “beep” once).
8. Open the oven doors and insert a load into the oven. Close the doors and press the Start Timer button. The time display will start to count down the remaining cook time.
If you open the oven doors, the fan and burners will temporarily shut off, and the time display will pause until the oven doors are closed again.
To turn on the oven interior light, press and hold the switch located at the bottom of the control panel.
During the cook time you can start or stop having the fan cycle on-and-off by pressing the Cycle button.
If necessary, you can adjust the remaining cooking time and/or oven temperature using the corresponding control knobs. You can also disable or enable Hold Mode.
To cancel a timed-cook, press the Cancel button.
9. What happens when the cook time runs out depends on whether Hold Mode is enabled.
 - If Hold Mode IS NOT enabled, the oven will start “beeping” and the time display will flash “:00”. Press the Cancel button to silence the alarm. Promptly remove the load from the oven OR open and leave open the oven doors. **If the oven doors are shut, the oven will maintain the set cook temperature.** To rapidly cool down the load, open the doors, switch the Fan Mode switch to COOL, and switch the Fan Speed switch to high (COOK).
 - If Hold Mode IS enabled, the oven will beep for 2 or 3 seconds to alert you that the cook time has completed. The time display will start counting up to indicate how long the load has been in Hold Mode. Later, after removing the load, press the Cancel button. **The oven will then heat up to the specified cook temperature in anticipation of the next load to be cooked.**



10. When you are done cooking, switch the Power Switch to OFF.

To RECORD a cook program to use later, do the following:

1. Press the Program Mode On/Off button.
2. Select which program you want to record by pressing the corresponding program button (PGM1, PGM2, PGM3, PGM4, or PGM5). The bottom line of the control panel display will indicate which program is being recorded. The temperature display will alternately flash the temperature setting and the event number being set (e.g., "E1," "E2"). Set a temperature, time duration, fan mode, and fan speed for the event, then press the Event # button to go on to the next event of the program.
3. Repeat Step 2 for each event in the program. Programs 1 and 2 can each have up to six events, while programs 3, 4, and 5 can each have up to four events. If the last event will be to enter Hold Mode, when you get to that event press the Hold button, then set a temperature and fan mode.

To check the program, you can step through the events by pressing the Event # button. The event number being shown will flash alternately with the temperature display, and the other control settings for the event will also be shown in the control panel window.

4. When you have entered the last event you want the program to include, press the Program Mode On/Off button. (If you have checked the program by stepping through the events with the Event # button, make sure that the last event that you want included in the program is being displayed before you press the Program Mode On/Off button. Any subsequent events in the program left over from an earlier program recording will be erased.)

To COOK using a cook program that you have recorded, do the following:

1. Turn the oven ON using the Power Switch at the top of the control panel.
2. Press the Program button (PGM1, PGM2, PGM3, PGM4, or PGM5) of the program that you want the oven to follow. The number of the program will appear on the bottom line of the control panel display.
3. Wait until the oven has reached cooking temperature (when it does, the temperature display will stop flashing and the oven will "beep" once).
4. Open the oven doors and insert a load into the oven. Close the doors and press the Start Timer button. The time display will start to count down the remaining cook time of the time period after the first event. As each subsequent cook event occurs, the control panel display will change to the settings that you programmed, and the time display will count down to the next event.

If you open the oven doors, the fan and burners will temporarily shut off, and the time display will pause until the oven doors are closed again.

To turn on the oven interior light, press and hold the switch located at the bottom of the control panel.

During the cook time you can start or stop having the fan cycle on-and-off by pressing the Cycle button.

To cancel a cook program, press the Cancel button.

5. What happens when the program's last cook period ends depends on whether the last event of the program is to enter Hold Mode.
 - If the last event of the program is a cook event (NOT to enter Hold Mode), when the program ends the oven will start "beeping" and the time display will flash ":00". Press the Cancel button to silence the alarm. Promptly remove the load from the oven OR open and leave open the oven doors. **If the oven doors are shut, the oven will maintain the cook temperature that was in effect before the program was started.** To rapidly cool down the load, open the doors, switch the Fan Mode switch to COOL, and switch the Fan Speed switch to high (COOK).
 - If the last event of the program IS to enter Hold Mode, when the last cook period ends the oven will beep for 2 or 3 seconds to alert you that the cooking has completed. The time display will start counting up to indicate how long the load has been in Hold Mode. Later, after removing the load, press the Cancel button. **The oven will then heat up to the cook temperature that was in effect before the program was started.**
6. When you are done cooking, switch the Power Switch to OFF.



Control Panel of RACK TIMER Models

OPERATION

Time Display

Displays remaining time for the rack with the least remaining cook time. When the timer runs out, the display will show the rack number of the rack which has timed out.

Racks-Being-Timed Indicators

Rack timers are running for the indicated racks. The name of the rack that will next finish will flash.

Time Knob

Turn to set the desired cook time.

Timer Buttons

Used to preset frequently used cooking times. To assign a time duration to one of these buttons, hold down the button and turn Timer Knob. Then to start a rack timer using that time duration, press the Timer Button and then press the appropriate Rack Button.

Rack Buttons

Press to start the timer of the corresponding rack (after specifying a time duration using either the Time Knob or a Timer Button).

Oven Interior Light Switch

Press to turn on the oven interior light. Light remains on for as long as the switch is held.

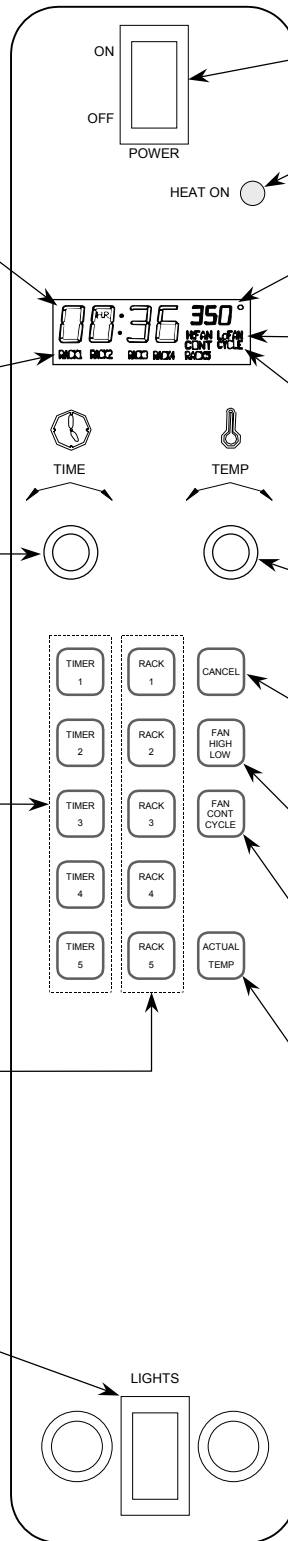

Power Switch

Use to switch oven on or off.

Heat-On Indicator

Lit when the burners are operating.

Temperature Setpoint Display

Indicates temperature setpoint. Flashes until setpoint is reached.

Fan Speed Indicator

Indicates fan speed is set to either High or Low.

Fan Mode Indicator

Indicates whether fan is set to run continuously (CONT) or to cycle on and off with the burners (CYCLE).

Temperature Knob

Turn to set the desired cooking temperature.

Cancel Button

Press to silence the beeping that starts when a timer runs out. To cancel a running timer, press the corresponding Rack Button, then press this button.

Fan Speed Button

Press to select whether fan runs at high or low speed.

Fan Mode Button

Press to select continuous or cycling fan mode.

Actual Temperature Button

Press to display the actual interior oven temperature instead of the desired temperature.



Operation of RACK TIMER Models

Rack Timer models have five independent timers, one for each rack. After loading a rack, you can start a timer for that rack. The control panel displays which racks are being timed, which rack will be the next to time out, and how much time remains before that happens. Of course, the oven temperature, fan speed, and fan mode are the same for all racks.

You can manually set a cooking time each time you load a rack, or you can preset up to five time durations that you can then recall by pressing the corresponding Timer Button. To assign a time duration to a Timer Button, hold down the corresponding button (TIMER1, TIMER2, TIMER3, TIMER4, or TIMER5), turn the Time Knob to the desired time, and release the Timer Button. Step 6 below describes how to use these buttons to set a rack's timer.

The rack timers are reminders to you of when to remove pans from the oven. **The rack timers do NOT control the temperature of the oven.**

To cook using the rack timers, do the following:

1. Turn the oven ON using the Power Switch at the top of the control panel.
2. Set the cooking temperature by turning the Temperature Knob. The setting appears in the top right corner of the control panel display. The displayed temperature will flash while the oven preheats.
3. Select the desired fan speed by pressing the Fan High/Low Button. The setting (HiFAN or LoFAN) appears in the control panel display just below the temperature setting. The appropriate fan speed depends on the type of food being cooked.
4. Select the desired fan mode by pressing the Fan Cont/Cyc Button. The setting appears in the control panel display just below the fan speed setting. In continuous mode (CONT), the fan will run when the oven is ON and the doors are closed. In cycle mode, the fan will run only when the doors are closed and the burners are operating.
5. Wait until the oven has reached cooking temperature (when it does, the temperature display will stop flashing and the oven will "beep" once). To display the actual temperature in the oven at any time, press the Actual Temp button.
6. Open the oven doors and insert a pan onto a rack. Close the doors and then either turn the Timer Knob until the desired cooking time appears on the control panel display, OR press the Timer Button that corresponds to a preset time that you have associated with that button. Finally, start the timer by pressing the Rack Button that corresponds to the just-loaded rack.

The time display will start to count down. The time display indicates the time remaining until the next time-out of a rack timer will occur. To display the time remaining for any rack, press the corresponding Rack Selector button. You can add additional pans at any time. The timer for each rack works independently.

The bottom line of the control panel display indicates which racks are presently being timed (RACK1, RACK2, RACK3, RACK4, and/or RACK5). The one that is flashing indicates which rack is the next one that will time out.

If you open the oven doors, all rack timers pause until the oven doors are closed again.

To turn on the oven interior light, press and hold the switch located at the bottom of the control panel.

To cancel any rack's timer (if, for example, you see that the food on that rack has finished cooking), press the corresponding Rack Button, then press the Cancel button.

7. When a rack's timer runs out, the time display will change to display a number corresponding to the rack that is done, and the control panel will "beep" repeatedly. Press the Cancel Button. If the oven continues to beep and the display shows another rack number, it means that rack's timer has also timed out. Press the Cancel Button until the oven stops beeping, noting which racks have timed out. Open the oven doors and remove the pan(s) from the timed-out rack(s). If you have more pans to be cooked, put them on the now empty rack(s) and set the rack's timer as appropriate (see Step 6).



COOKING HINTS

In a standard (non-convection) oven, the air is relatively still and an insulating layer of moisture surrounds the cooking food product. In a convection oven, the fan-blown circulating air strips away this insulating layer allowing the heat to penetrate faster for quicker baking and roasting. Hence, in a convection oven cooking procedures and techniques may require some modification for successful results. As a general rule, the cooking time will be shorter and the cooking temperature will be 25°F to 75°F lower than those called for in recipes for a standard oven.

TIME & TEMPERATURE

Time and temperature are important. The “Guide to Times and Temperatures” later in this section is a starting point. The actual best cooking time and temperature will depend on such factors as size of load and mixture of recipe (particularly moisture). Once an appropriate time and temperature has been established for a particular product and load, you will find the result of succeeding loads to be similar.

OVERLOADING

Do NOT overload the oven. The size of the load that can be cooked satisfactorily depends largely on the particular product. As a rule, five racks can be successfully used for shallow cakes, cookies, pies, etc. For deeper cakes (such as angel food), use only three racks because of the size of the pan and the space required for rising. For hamburger patties, fish sticks, cheese sandwiches, etc., a full complement of racks and pans is usually satisfactory.

HELPFUL SUGGESTIONS

Here are some suggestions that will assist in getting the best possible performance from a convection oven:

- Pre-heat the oven thoroughly before use.
- When re-thermalizing frozen products, pre-heat the oven to 50°F higher than the planned cooking temperature. After loading, reduce the temperature setting to the appropriate cooking temperature.
- Space the racks and pans as evenly as possible to allow air circulation.
- Center the load on the racks to allow for proper air circulation around the sides. Do not cover the racks completely with pans.
- Do not use a deep pan for shallow cakes or cookies, etc. Air circulation across the surface of the product is essential.

WARNING

THE USE OF ALUMINUM FOIL CAN CAUSE HEAT DISTRIBUTION PROBLEMS IN OVENS. EXTREME CARE MUST BE USED WHEN PLACING ALUMINUM FOIL IN THE OVEN TO ENSURE THAT IT DOES NOT BLOCK OR CHANGE THE AIR FLOW. THE USE OF ALUMINUM FOIL MAY VOID THE PRODUCT WARRANTY IF ITS USE IS ASCERTAINED TO BE A PROBLEM.

HOLDING FOOD BEFORE SERVING

Any food item prepared in steam table pans can be held until being served by setting the Hold thermostat to 160°F. Examples include stuffed pork chops, oysters Rockefeller, and any vegetable entree.





	Cooking Time	Temperature	Number of Racks
Baked Goods			
Bread, 2 lb. loaf	35 min.	375°F	3
Biscuits	5-10 min.	400°F	5
Cornbread	18 min.	400°F	5
French Bread	10 min.	375°F	5
Sheet Cake	18-20 min.	300°F	5
Cream Puffs	20 min.	375°F	5
Brown & Serve Rolls	6 min.	400°F	5
Ginger Bread	18 min.	300°F	5
Yeast Rolls, sheet pan	16-18 min.	325°F	5
Pineapple Upside Down Cake	25-30 min.	325°F	5
Apple Turnovers	15-18 min.	350°F	5
Fruit Cobbler	22-25 min.	375°F	5
Brownies	15 min.	350°F	5
Danish Pastry	12 min.	325°F	5
Pie Shells	12 min.	350°F	5
Fresh Fruit Pies	25-30 min.	350°F	5
Pumpkin Pies	25-30 min.	275°F	5
Fresh Apple Pies	35 min.	375°F	5
Frozen Berry Pies	40 min.	375°F	5
Frozen Fruit Pies	45 min.	375°F	5
Potatoes			
Baked Potatoes, 10 oz.	50-55 min.	450°F	5
Baked Potatoes, 6-8 oz.	40-45 min.	450°F	5
Scalloped Potatoes	35 min.	325°F	5
Miscellaneous			
Macaroni and Cheese	30 min.	350°F	5
Stuffed Peppers	18 min.	350°F	5
Toasted Cheese Sandwiches	8 min.	375°F	5



CLEANING

Southbend equipment is sturdily constructed of the best materials and is designed to provide durable service when treated with ordinary care. To expect the best performance, your equipment must be maintained in good condition and cleaned daily. Naturally, the periods for this care and cleaning depend on the amount and degree of usage.

Following daily and periodic maintenance procedures will enhance long life for your equipment. Climatic conditions (such as salt air) may require more thorough and frequent cleaning or the life of the equipment could be adversely affected.

The oven interior is finished with a porcelain enamel coating. "Spillovers" should be cleaned from the interior bottom surface as soon as possible to prevent carbonizing and a burnt-on condition. Grease or any residue should be cleaned from interior surfaces as soon as it accumulates.

WARNING

FOR YOUR SAFETY, DISCONNECT THE POWER SUPPLY TO THE APPLIANCE BEFORE CLEANING.

WHEN CLEANING THE BLOWER WHEEL, BE SURE TO HAVE THE POWER SWITCH IN THE "OFF" POSITION.

DAILY CLEANING

1. Turn the power switch to OFF and allow the oven to cool.
2. Remove the oven-interior racks and rack slide frames. (The rack slide frames are readily removable by merely raising to disengage them from their sockets.) Wash the racks and rack slides in a sink with mild detergent and warm water. Dry them thoroughly with a clean cloth.
3. Look to see if any foreign matter has accumulated on the blades of the blower wheel (which will reduce air circulation). If necessary, remove the rear lining of the oven, which is secured by thumbscrews near each corner. Use a stiff brush to remove accumulations from the blower blades, then wash with soap and water.
4. Wash the interior surfaces with mild detergent and warm water. Rinse with clean water, and dry thoroughly with a clean cloth. For stubborn accumulations, a commercial oven cleaner may be used.
5. Clean the control panel with warm water and mild soap. Never use cleaning solvents with a hydrocarbon base.
6. Wipe the other exterior surfaces with a clean damp cloth. If the exterior surfaces require more thorough cleaning, see "Cleaning Stainless Steel Surfaces" on the next page.
7. Return the rack slides and racks to their appropriate locations inside the oven.
8. LEAVE THE DOOR OPEN AT NIGHT AFTER CLEANING. This allows the oven to dry thoroughly after cleaning and also prolongs the life of the door gasket.

MONTHLY CLEANING

Clean around rear of motor (where the vent screen is located), louvered panels, and primary air holes in the rear of the oven where grease or lint may have accumulated.

OVENS



ADJUSTMENTS

WARNING

ADJUSTMENTS AND SERVICE WORK MAY BE PERFORMED ONLY BY A QUALIFIED TECHNICIAN WHO IS EXPERIENCED IN, AND KNOWLEDGEABLE WITH, THE OPERATION OF COMMERCIAL COOKING EQUIPMENT. HOWEVER, TO ASSURE YOUR CONFIDENCE, CONTACT YOUR AUTHORIZED SERVICE AGENCY FOR RELIABLE SERVICE, DEPENDABLE ADVICE OR OTHER ASSISTANCE, AND FOR GENUINE FACTORY PARTS.

NOTICE

Warranty will be void and the manufacturer is relieved of all liability if service work is performed by other than a qualified technician, or if other than genuine Southbend replacement parts are installed.

LUBRICATION

The door chains and sprockets have been lubricated at the factory with high temperature "Never Seeze" lubricant. After each six months of usage, lubricate the door chains and sprockets with the same type of lubricant.

Motor lubrication information can be found on permanent label located on motor.

Casters are provided with a Zerk fitting for proper lubrication when required.

ADJUSTING GAS PRESSURE REGULATOR

The pressure regulator is factory set at 4.5" W.C. for natural gas and 11" W.C. for propane gas. To check the manifold pressure:

1. Turn all thermostats and burner valves to "OFF" position.
2. Turn main gas valve to entire unit off.
3. Remove valve panels and locate 1/8" plug in manifold.
4. Remove plug and install a fitting appropriate to connect a manometer.
5. Turn on main gas to unit and light pilots.
6. Turn all burners and ovens to full "ON" position and read manometer.
7. If manometer does not read 4.5" W.C. for natural gas, or 11" W.C. for propane gas, adjust regulator (if gas pressure is O.K. go to Step 10).
8. Remove cap from top of regulator.
9. With a screwdriver rotate regulator adjustment screw clockwise to increase, or counterclockwise to decrease, pressure until manometer shows correct reading.
10. Repeat steps 1 and 2.
11. Remove manometer fitting and replace plug in manifold.
12. Repeat step 5.
13. Replace valve panels.



ADJUSTING DOOR CHAIN MECHANISM

The door chain mechanism causes the left and right doors to open and close together. To adjust the door chain mechanism, do the following:

1. Remove lower front panel that covers the door chain mechanism (shown below).
2. Close both doors.
3. Check the positioning of the chain on the sprockets. There should be five regular links and one master link visible on the front side of each chain. If not, open the turnbuckles and reposition the chain over the sprockets.
4. Adjust the turnbuckles so that the right door closes about 1/4" to 1/2" inch ahead of the left door. The left door should be pushed tight over the friction catch so both doors are completely closed against the frame.
5. Secure the turnbuckles by tightening their locknuts.

ADJUSTING DOOR SWITCH

The door switch detects when the oven doors are open. As adjusted at the factory, when the doors are opened more than 2 to 4 inches, the burners and fan should shut off (unless the fan is switched to "COOL" mode). To adjust the door switch, do the following:

1. Remove lower front panel that covers the door chain mechanism.
2. Close both doors.
3. Check that the door switch striker bar is attached to the door chain's first and second links (after the master link). If necessary, adjust or repair the door switch striker bar.
4. With the doors closed, loosen the two screws that hold the door switch bracket to the oven frame (shown below). Slide the bracket left or right until the plunger arm on the door switch is being depressed 1/8".

CAUTION

Do NOT adjust the door switch so that the plunger arm is completely depressed and is hitting the switch body. This could distort the arm and cause the switch to operate poorly.

5. Tighten the screws holding the door switch bracket to the oven frame.

ADJUSTMENTS

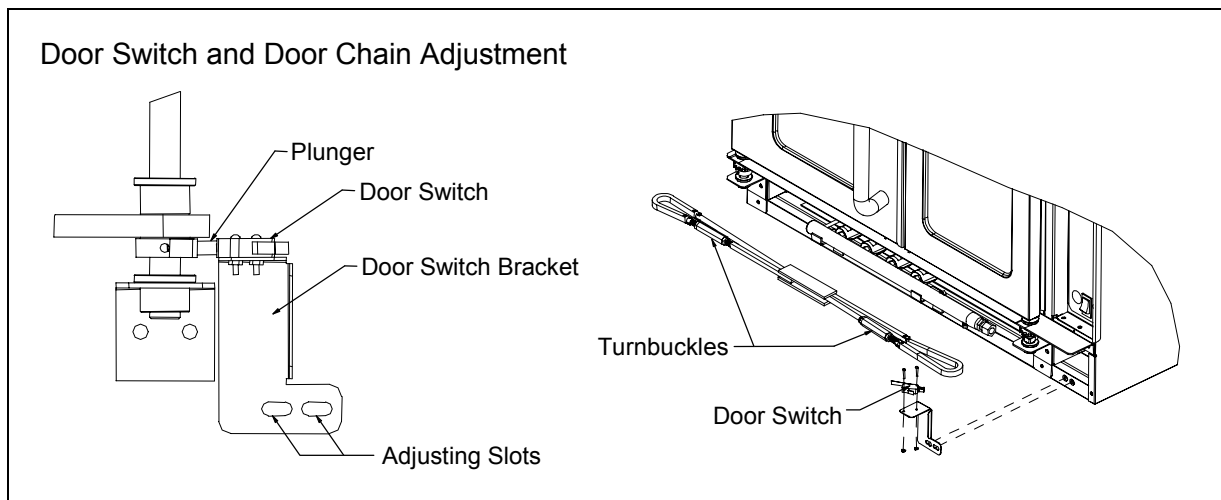



TEMPERATURE CONTROLLER (Standard-Control Models Only)

The calibration of the temperature controller should not be changed until sufficient experience with cooking results has definitely proved that the temperature controller is not maintaining proper oven temperatures. Before any recalibration is attempted, the oven temperature should be checked by the following procedure:

1. Remove all trays and pans from the oven.
2. Place a thermocouple or a reliable mercury oven-type thermometer at the center of the middle rack.
3. Turn the oven ON and set the temperature control knob to 400°F.
4. The amber "heat on" light will go out when the oven temperature is reached.
5. Allow three cycles for the temperature to stabilize.
6. Read the thermocouple or thermometer immediately after the light goes out for the third time, and again immediately after it comes on the next time.
7. If the average of these readings varies by more than 10°F from the dial setting, recalibrate by the following procedure. **Recalibration should be attempted only by a competent service technician.**

Use the following procedure to recalibrate the oven:

1. Loosen the two set screws that secure the temperature-control knob to the temperature-control shaft.
2. Remove the knob from the shaft, being careful not to rotate the knob or shaft.
3. Replace the knob on the shaft so that the indicator mark on the knob points directly at the temperature that was measured at the center of the oven.
4. Re-check the oven calibration.

FAHRENHEIT OR CELSIUS DISPLAY (Cycle/Cook & Hold Models Only)

Ovens with Cycle/Cook & Hold controls can be configured to display temperatures using the Fahrenheit or the Celsius scales. To change the choice, change the position of the blue jumper "J3" on the rear of the control panel circuit board.



TROUBLESHOOTING

WARNING

ADJUSTMENTS AND SERVICE WORK MAY BE PERFORMED ONLY BY A QUALIFIED TECHNICIAN WHO IS EXPERIENCED IN, AND KNOWLEDGEABLE WITH, THE OPERATION OF COMMERCIAL COOKING EQUIPMENT. HOWEVER, TO ASSURE YOUR CONFIDENCE, CONTACT YOUR AUTHORIZED SERVICE AGENCY FOR RELIABLE SERVICE, DEPENDABLE ADVICE OR OTHER ASSISTANCE, AND FOR GENUINE FACTORY PARTS.

NOTICE

Warranty will be void and the manufacturer is relieved of all liability if service work is performed by other than a qualified technician, or if other than genuine Southbend replacement parts are installed.

In case of problems in operation at initial installation, check type of gas and manifold pressure and compare with information listed on the serial plate. The serial plate is located inside the lower front panel.

PERFORMANCE STANDARD

The typical time for the oven to heat from 75°F to 350°F is 5 to 6 minutes for ovens using natural gas, and 7 to 8 minutes for ovens using propane.

The burners should come on when the actual oven temperature drops to 10°F below the temperature setting.

INTERPRETING DISPLAYED ERROR CODES

Programmable and Rack Timer models are able to detect some problems that might occur. If the control panel display is showing a letter "F" followed by a number, consult the following table to determine the problem and appropriate corrective action.

Symptom	Possible Cause	Check or Replace
Display shows F1	Bad temperature controller.	Replace temperature controller.
Display shows F2	Oven interior maximum temperature exceeded.	Check whether gas valve is stuck open. If not, replace temperature controller.
Display shows F3	Open temperature probe.	Check connection. If connection is OK, replace probe.
Display shows F4	Shorted temperature probe.	Check probe wires. If wires are not shorted, replace probe.
Display shows F5	Bad temperature controller.	Replace temperature controller.
Display shows F6	Bad temperature controller.	Replace temperature controller.
Display shows F7	Total cook time in a program exceeds 24 hours (programmable models only).	Change program so that total cook time does not exceed 24 hours.
Display shows F8	Bad temperature controller.	Replace temperature controller.

TROUBLESHOOTING

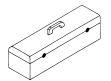

TROUBLESHOOTING GUIDE

The left column of the following table lists symptoms that indicate a problem, while the center and right columns list the possible causes and appropriate corrective action. Note that the recommendations of this table assume that the wiring connections are good. When checking a component, always check the wiring attached to the component as well.

Symptom	Possible Cause	Check or Replace
Oven will not hold correct temperature.	Temperature probe not working.	Resistance across temperature probe leads at room temperature (70°F) should be approximately 1096 ohms.
	Temperature control not calling for heat.	When heat is required, there should be continuity between terminals 6 and 7 on temperature control.
	Undersized gas supply line	Oven requires 3/4" ID gas line.
	Low gas pressure.	Oven requires 7" manifold water column pressure for natural gas, 11" for propane.
	Inadequate or improper ventilation.	Check ventilation hood. Verify draw and make up air adjustment.
	Out of calibration.	Calibrate according to procedure described on page 41.
Hot surface ignitor glows red but burners do not come on when thermostat calls for heat (cooking light is on).	No power to gas valve.	Check for 24V from ignition box to gas valve.
	Faulty main gas solenoid.	Replace gas valve.
	Faulty ignition module.	Replace ignition module.
	Manual shutoff valve closed.	Open all shut-off valve.
	Manual valve on gas valve turned off.	Open manual valve on gas valve.
	Hot surface ignitor not in front of rear end of burner.	Re-position hot surface ignitor to be in front of rear end of burner.
Hot surface ignitor does not glow red.	No power to ignitor.	Check that voltage from ignitor module to ignitor is 24V. Ignitor draws approximately 3.35 amps at start as it heats up resistance goes down. Gas valve opens approximately 1.8 amps.
	Ignitor broken or cracked.	Should read continuity between leads on ignitor.
	No power or ignition module.	Should be 24V from transformer to ignition module.
	Check power to transformer.	Should be voltage stamped on serial plate. Check between 3 and 6 on terminal strip.
	Check blower motor. Motor should turn when power switch is turned on and temperature control calls for heat.	Motor has centrifugal switch. Motor must be turning before ignition circuit is energized. Power for motors come through contactors. Check contactors (one for high speed, one for low speed).
	Temperature control does not call for heat.	Must read continuity between 6 and 7 on temperature control when calling for heat.
	No power out of power switch.	Check that unit power cord is plugged into power supply. Check switch for continuity when switch is closed.
First burner next to ignitor lights, but flame will not carry across to other burners.	Burners not aligned.	Check burner carry over wings for proper mating.
	Burner and orifice out of alignment.	Orifice must inject gas down center of burner.
	Gas pressure to low.	Oven requires 7" manifold water column pressure for natural gas, 11" for propane.
	Burner orifices clogged.	Make sure burner orifices are clear.

Table continues on next page.

TROUBLESHOOTING



TROUBLESHOOTING GUIDE (continued)

Symptom	Possible Cause	Check or Replace
Burners light but go out within a few seconds. (Ignitor will glow approximately 4 seconds. If burner does not ignite, ignition module will try 3 times and then lock out.)	Bad flame switch.	Check in series on micro amps. Minimum is 0.75 amps, no maximum.
	Bad gas valve.	Check gas valve. Should be 24 volts from ignition module on wires 46 and 47.
Blower motor will not come on.	No incoming electric power.	Check incoming power.
	Loose wire connections.	Check wire connections.
	Bad contactors.	Contactors pull in and supply power to motor. Verify contactor pulling in.
	Motor bad.	If power is being supplied but motor will not turn, replace motor.
	Shut down switch.	All power except for motor supply come through shut down switch. Check for continuity.

CONTROL PANEL ACCESS AND SHUT-OFF SWITCH

To access the control panel components, remove the screw at the top of the control panel and pull the top of the control panel out and down (see drawing below). A wiring diagram for the oven is located on the side of the control panel assembly. **When the control panel is folded down, all power to the control panel is cut off by a shut down switch that is located directly behind and below the control panel.** To re-energize the controls for troubleshooting, pull the white plunger on the shut down switch up.

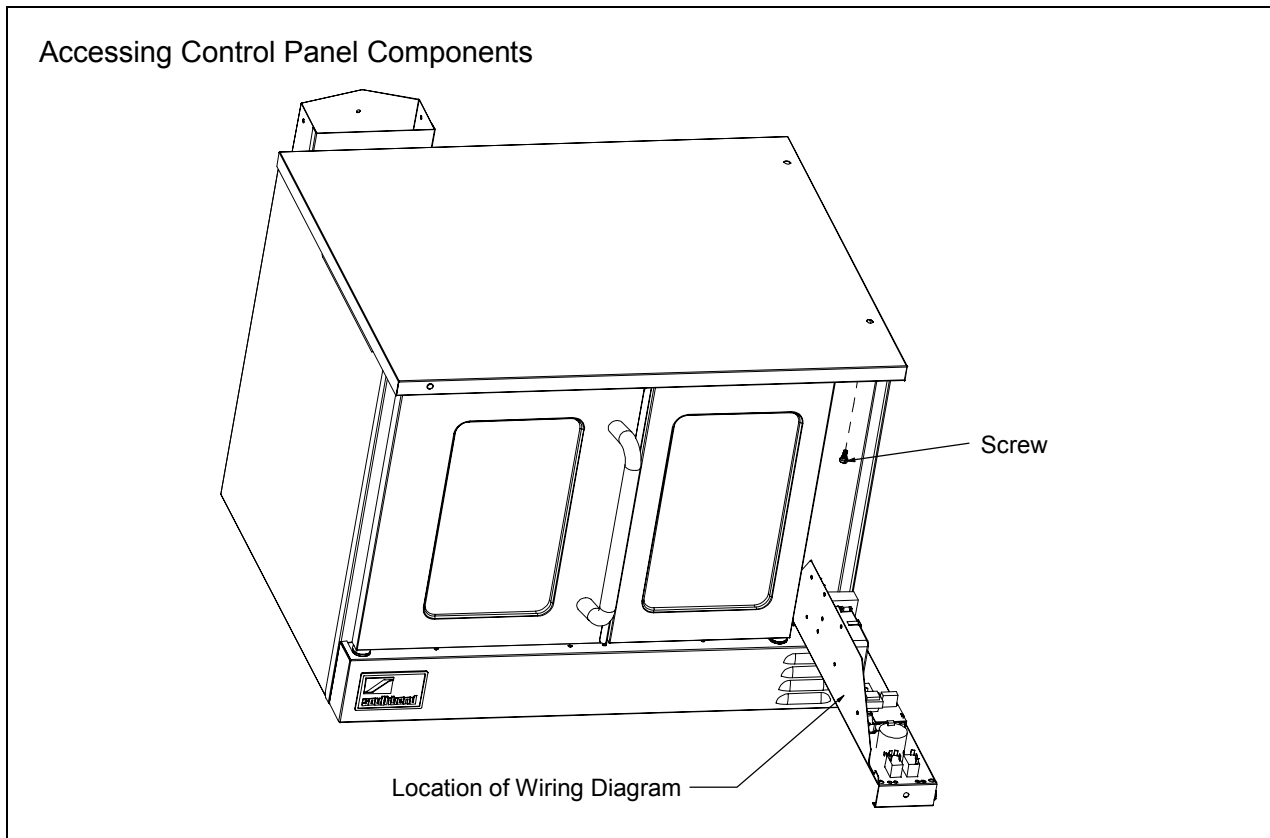

TROUBLESHOOTING

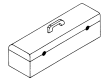

BLOWER WHEEL REPLACEMENT

To replace the blower wheel, do the following:

1. Remove racks and rack guides.
2. Remove rear air baffle in front of blower wheel.
3. Loosen the two square heads on blower wheel hub.
4. Pull blower wheel from motor shaft. If blower wheel is difficult to pull off, use puller disk (available from Southbend Technical Service Department as part number 1179100).



Electrical Schematic for 120 Volt Models with Standard Controls

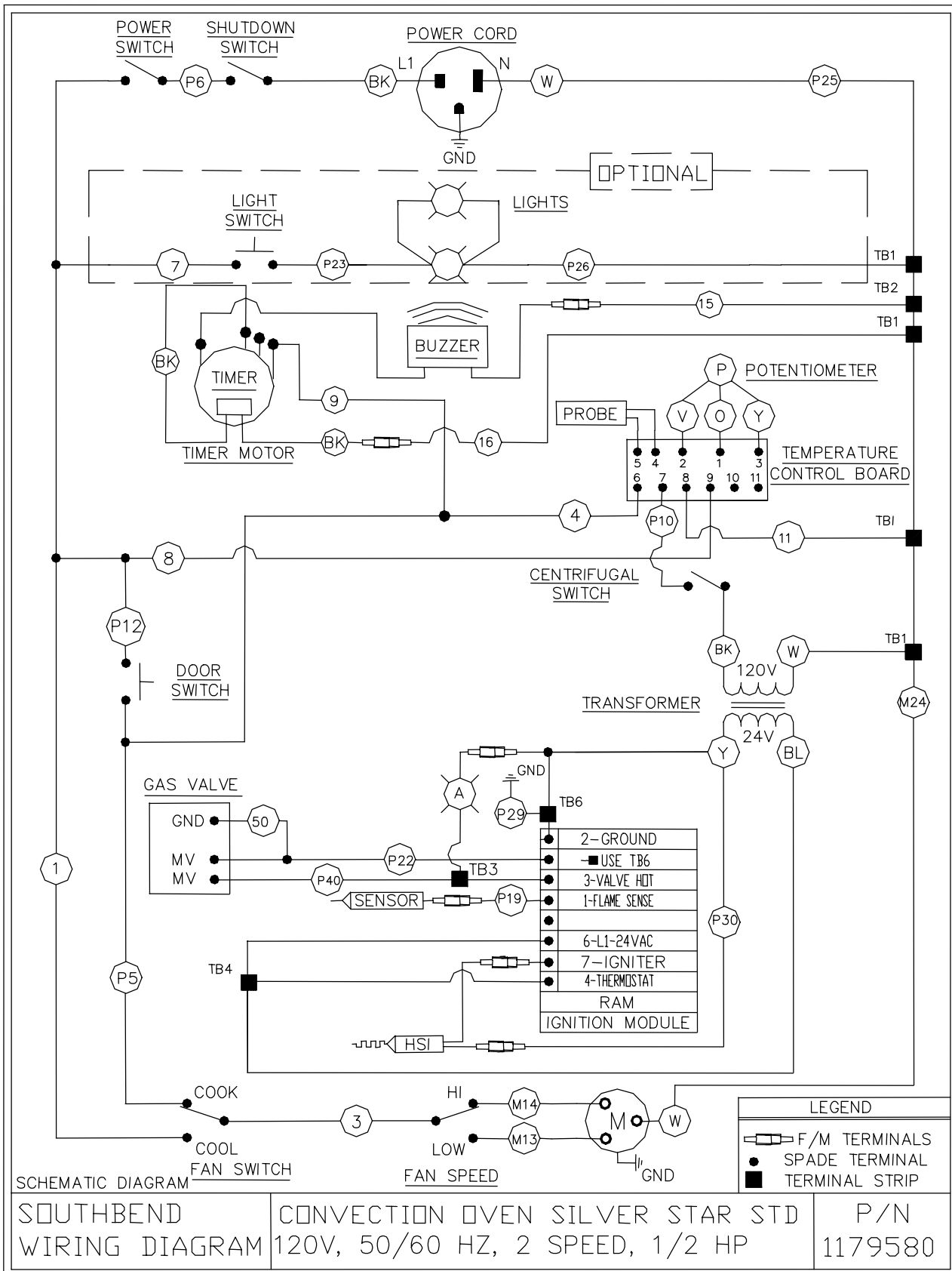

TROUBLESHOOTING

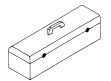

Electrical Schematic for 208-240 Volt Models with Standard Controls

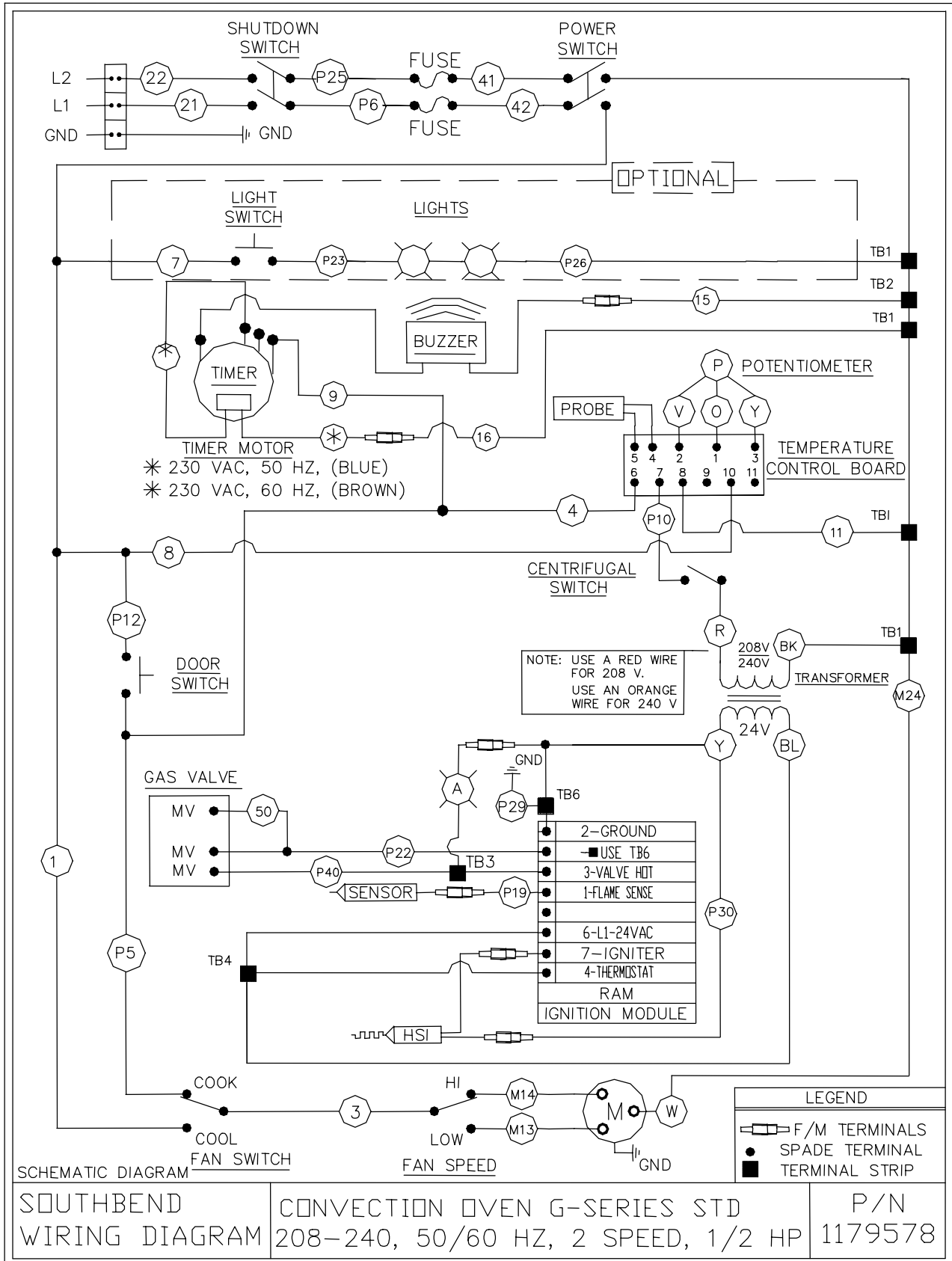

TROUBLESHOOTING

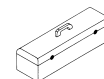

Electrical Schematic for 208-240 Volt Models with Cycle/Cook and Hold Controls

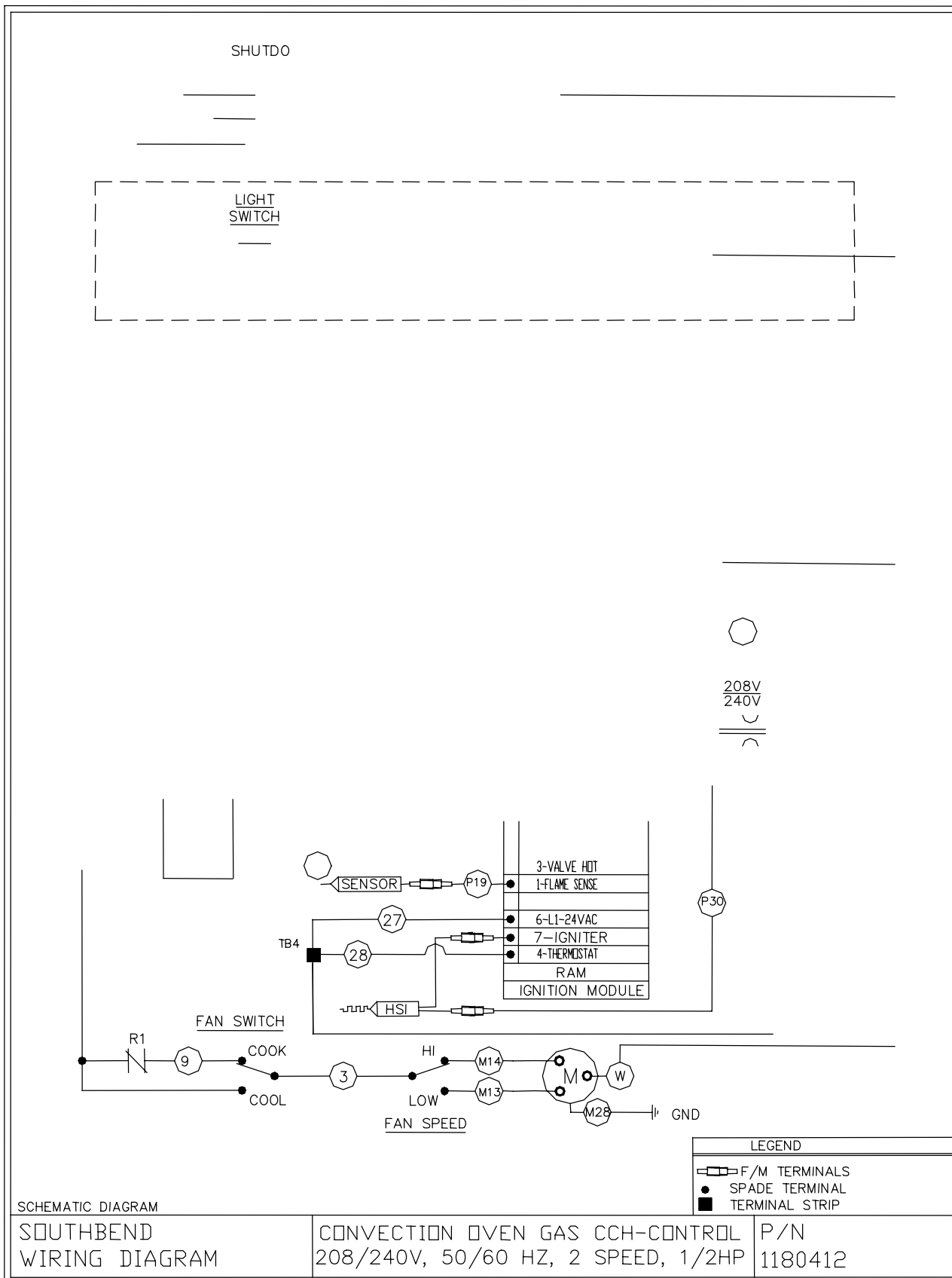

TROUBLESHOOTING



Electrical Schematic for 120 Volt Models with Programmable or Rack Timer Controls

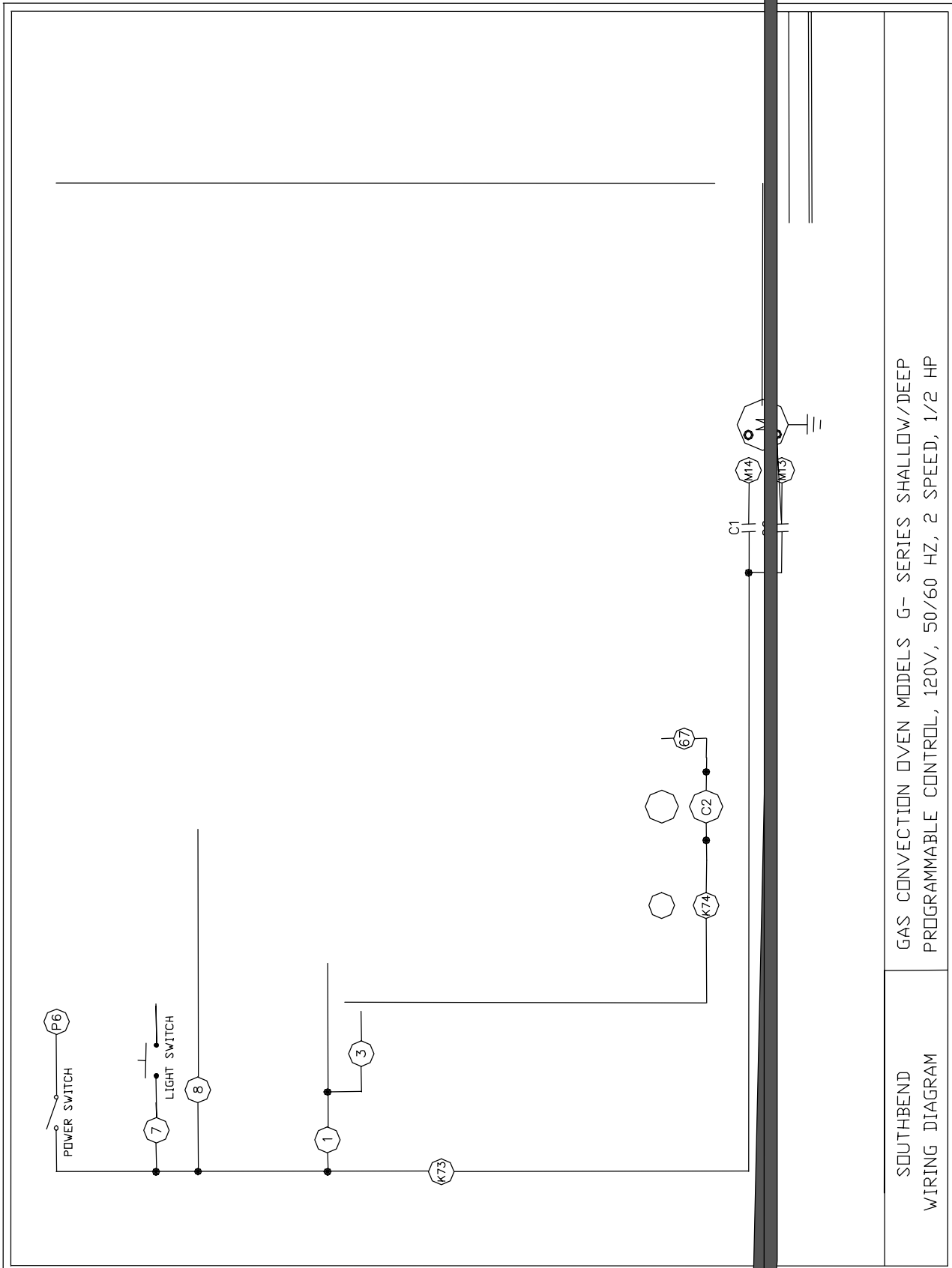

GAS CONVECTION OVEN MODELS G- SERIES SHALLOW/DEEP PROGRAMMABLE CONTROL, 120V, 50/60 HZ, 2 SPEED, 1/2 HP

SOUTHBEND WIRING DIAGRAM

TRUBLESHOOTING



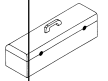

Electrical Schematic for 208-240 Volt Models with Programmable or Rack Timer Controls

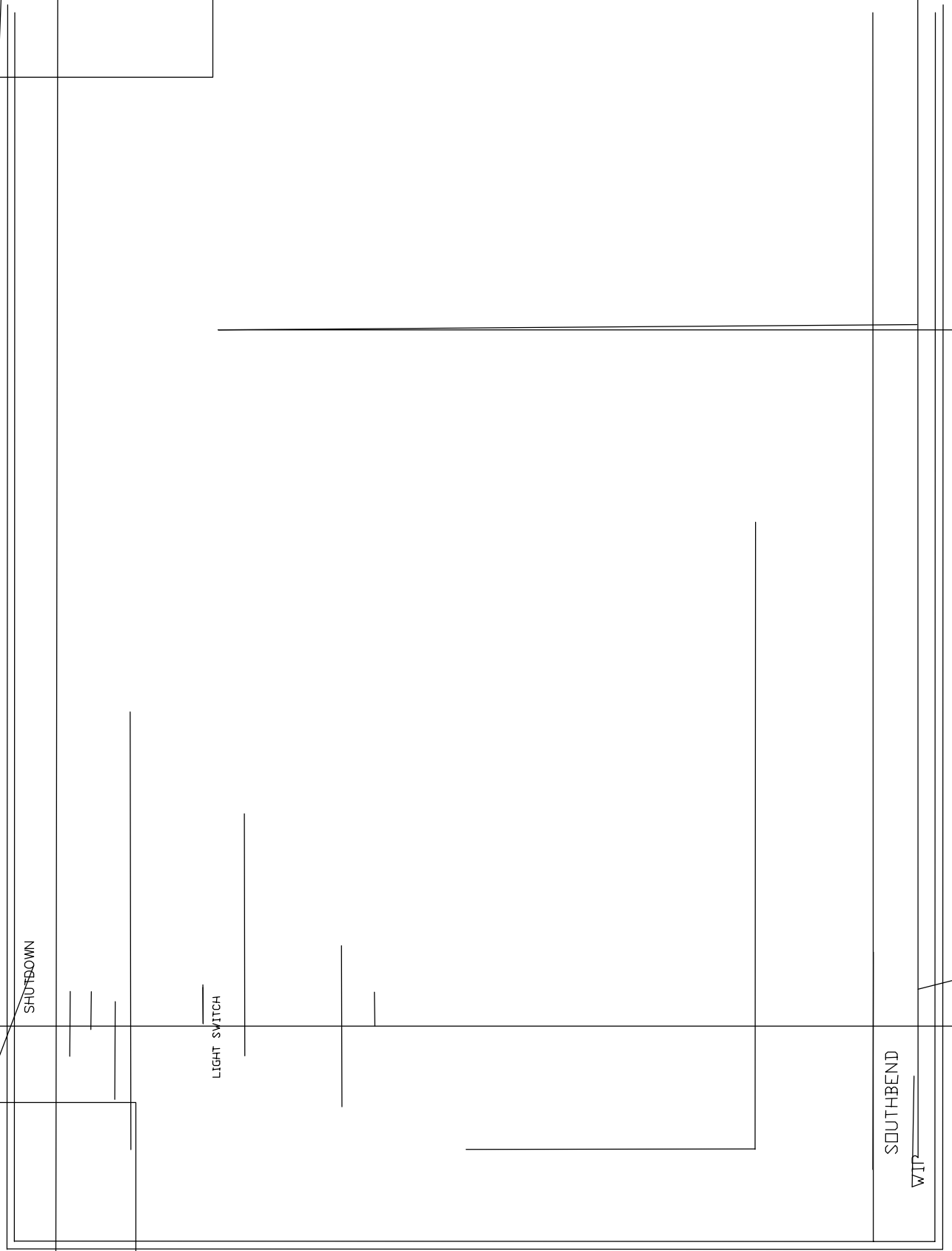

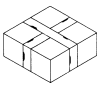

PARTS

NOTICE

INSTALLATION OF OTHER THAN GENUINE SOUTHBEND PARTS WILL VOID THE WARRANTY ON THIS EQUIPMENT.

The serial plate with voltage, model, and serial information is located inside the lower front panel of the oven.

Replacement parts may be ordered either through a Southbend Authorized Parts Distributor or a Southbend Authorized Service Agency.

When ordering parts, please supply the Model Number, Serial Number, Part Number, Description, Finish, and Electrical Characteristics as applicable.

For parts not listed, consult a Southbend Authorized Parts Distributor or Southbend Authorized Service Agency. Consult the Southbend Authorized Parts/Service Distributor list for the Authorized Parts supplier in your area. If this list is not available, call Southbend at 1-800-348-2558 to obtain this list.

Index of Parts Diagrams

Page Number	Description
53	Front Panel and Flue Parts
54	Door Parts
55	Door Chain Mechanism Parts
56	Control Panel Parts for Models with Standard Controls
58	Control Panel Parts for Models with Cycle/Cook and Hold Controls
60	Control Panel Parts for Models with Programmable Controls
62	Control Panel Parts for Models with Rack Timer Controls
64	Internal Gas Supply Parts
65	Burner Compartment Parts
66	Oven Interior and Fan Motor Parts
67	Oven Light Parts
68	Leg Parts for Single-Deck SilverStar Models
69	Leg Parts for Single-Deck Marathoner Gold Models
70	Storage Rack Parts
71	Double-Deck Oven Stacking Parts
72	Leg Parts for Double-Deck Ovens

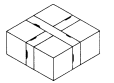

Front Panel and Flue Parts

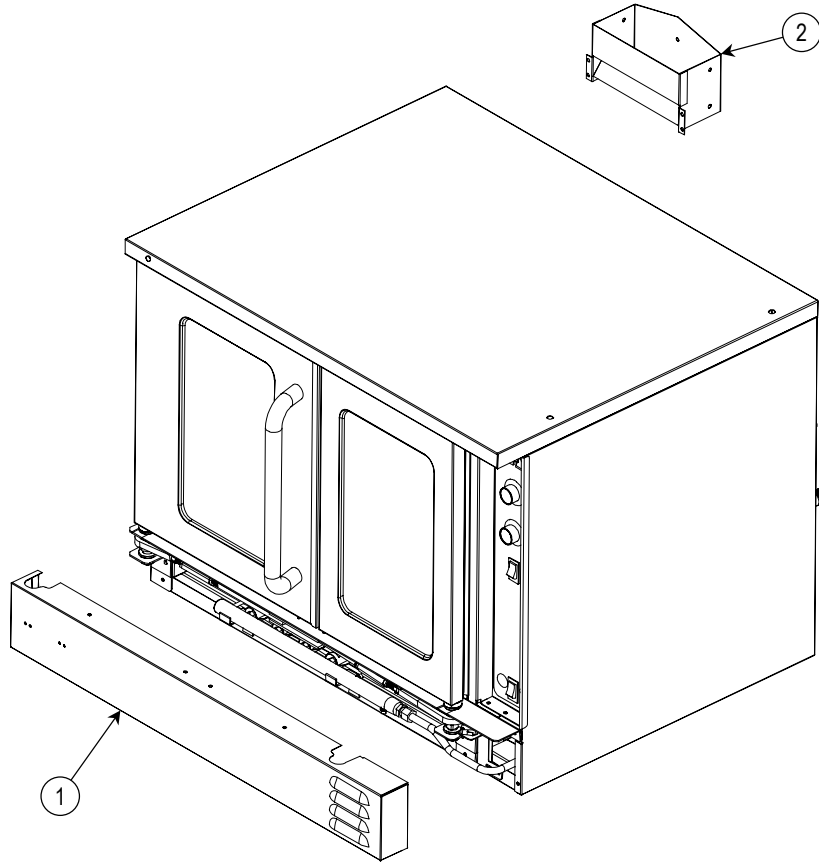

Key	Part Number	Qty	Description
1	1177867	1	Panel, front louver, co
2	1181838	1	Flue box, w/a, co
*	4440502	1	Down draft diverter kit
* not shown on drawing.			

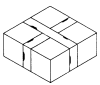

Door Parts

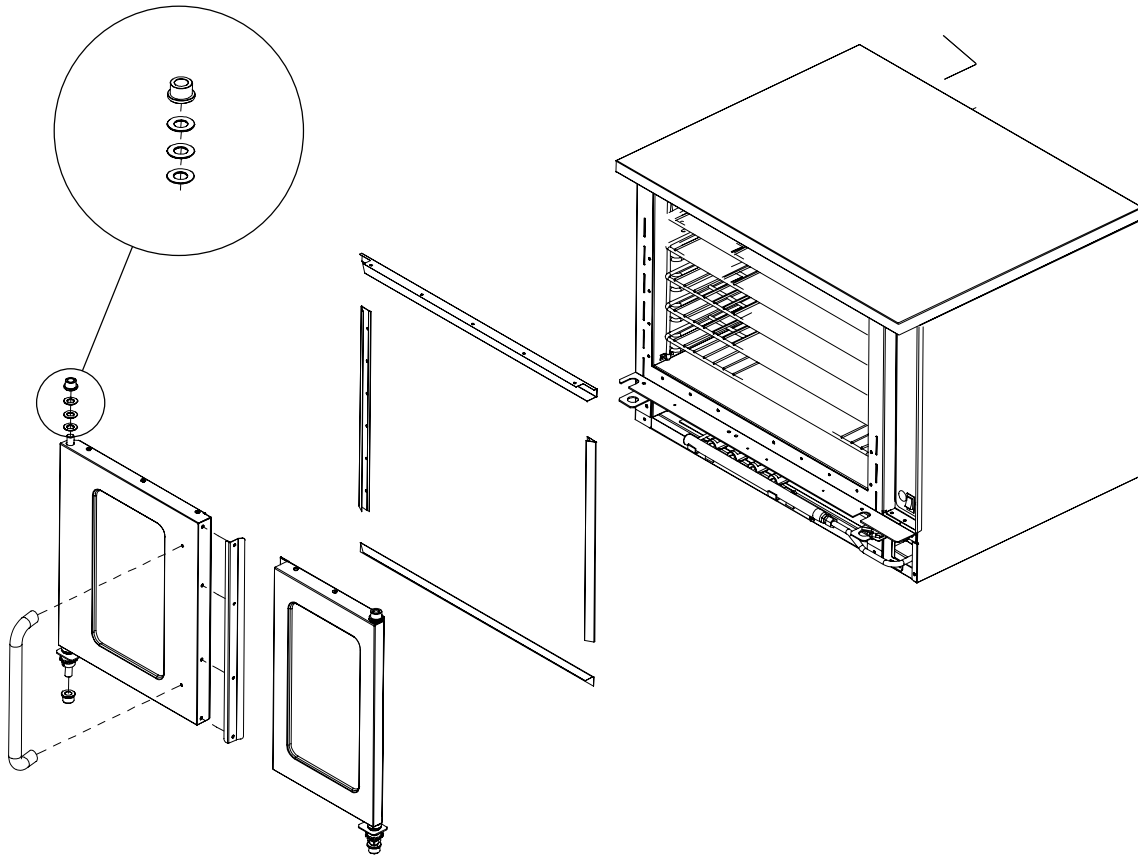

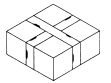

Door Chain Mechanism Parts

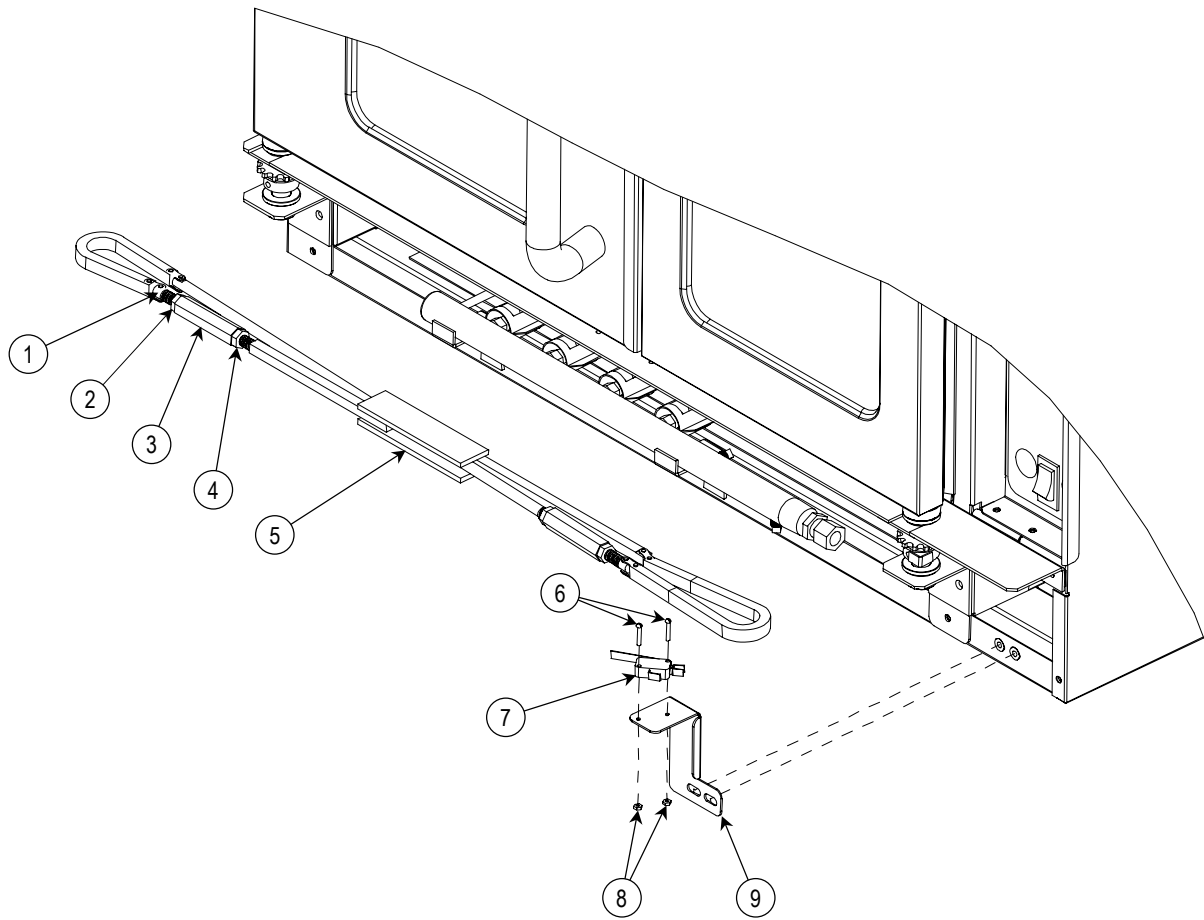

Key	Part Number	Qty	Description
1	1164523	4	Pivot rod
2	1164551	2	Nut, 3/8-16, hex head, right hand threaded
3	1164522	2	Turnbuckle, 2 3/4" long, brass
4	1164552	2	Nut, 3/8-16, jam, left hand threaded
5	1175214	1	Door mechanism, weld asm
6	1172326	2	Screw, #4-40 x 3/4, zinc plated
7	1177567	1	Switch, door, spdt, 15 amp
8	1172327	2	Nut #4-40, zinc plated, hex
9	1181956	1	Bracket, door switch (for units built before February 15, 2001)
	1183358	1	Bracket, door switch (for units built after February 14, 2001)

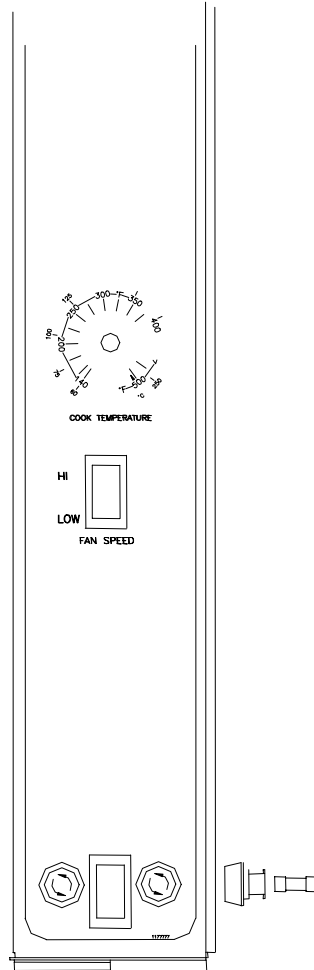
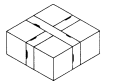



Control Panel Parts for Cycle/Cook and Hold Models (CCH Models)

See drawing on following page.

Key	Part Number	Qty	Description
1-20	1180409	1	Control panel assembly, CCH, 60Hz, M-Gold, 120V (assembled, w/o wiring harness)
1-21	1180485	1	Control panel assembly, CCH, 60Hz, M-Gold, 208/240V (assembled, w/o wiring harness)
1-20	1180410	1	Control panel assembly, CCH, 60Hz, SilverStar, 120V, w/lights (assembled, w/o wiring harness)
1-20	1180492	1	Control panel assembly, CCH, 60Hz, SilverStar, 120V, w/o lights (assembled, w/o wiring harness)
1-21	1180486	1	Control panel assembly, CCH, 60Hz, SilverStar, 208/240V, w/lights (assembled, w/o wiring harness)
1-21	1180494	1	Control panel assembly, CCH, 60Hz, SilverStar, 208/240V, w/o lights (assembled, w/o wiring harness)
*	1180482	1	Wiring harness, CCH, 120V (includes terminal block 1170335)
	1180483	1	Wiring harness, CCH, 208/240V (includes terminal block 1170335)
1	1180479	1	Front control panel s/a, CCH
2	1180350	1	Polypanel, CCH, M-Gold
	1180411	1	Polypanel, CCH, SilverStar
3	1177541	1	Rocker switch-DPST- (on-off)
4	1177598	1	Valve location label
5	1177540	2	Rocker switch-SPDT (on-on)
6	1180402	1	Relay, 120V
	1180499	1	Relay, 208/240V
7	6600430	8	Locknut, #8-32
8	1146397	6	Screw, #8-32x5/8 pan head
9	1180404	4	Spacer, control
10	1146400	4	Nut, #6-32 hex
11	1180407	1	Control, CCH
12	1177515	1	Clamp, RAM module
13	1146362	2	Screw, #8-32x1-5/8 Phillips truss head
14	1175723	1	Ignition control module 24VAC
15	1172277	1	Transformer, 120/208/240-24V
16	1170335	1	Terminal block
17	1170336	1	Marker strip
18	1175046	1	Left control panel hinge
19	1177789	1	Rocker switch-SPST momentary (for models with the oven light option)
	1177642	1	Plug, square (for models without the oven light option)
20	1177564	2	Plug, round (120V models)
	1170424	2	Fuse holder (208/240V models)
21	1170425	2	Fuse, 12 amp #LP-CC-12 low peak (208/240V models only)
*	1181996	1	Temperature probe

* not shown on drawing.





Control Panel Parts for Models with Programmable Controls (PC Models)

See drawing on following page.

Key	Part Number	Qty	Description
1-22	1179627	1	Control panel assembly, PC, M-Gold, 120V (assembled, w/o wiring harness)
1-23	1179633	1	Control panel assembly, PC, M-Gold, 208/240V (assembled, w/o wiring harness)
*	1179628	1	Wiring harness, PC, 120V (includes terminal block 1170335)
	1179634	1	Wiring harness, PC, 208/240V (includes terminal block 1170335)
1	1179706	1	Digital control panel weld asm
2	1177786	1	Polypanel, programmable control
3	1177598	1	Valve location label
4	1177541	1	Rocker switch-DPST- (on-off)
5	1177565	1	Light, (amber) 24V
6	1161449	2	Contactora, two pole, 120V
	1161525	2	Contactora, two pole, 240V
7	1146399	4	Screw #10x1/2 Phillips truss (blunt)
8	1175742	1	Mount, motor contactor
9	1172271	1	Programmable control
10	1146397	4	Screw 8-32 x 5/8 s/steel pan head
11	1172277	1	Transformer, 120/208/240-24
12	6600430	8	Locknut 8-32
13	1175723	1	Ignition control module 24VAC
14	1177515	1	Clamp, RAM module
15	1170335	1	Terminal block
16	1170336	1	Marker strip
17	1179702	1	Harness, contactor PC/RT
18	1146362	2	Screw 8-32 x 1-5/8 lg. Phillips truss hd
19	1179629	1	RAM mounting bracket
20	1175046	1	Left control panel hinge
21	1177789	1	Rocker switch-SPST momentary
22	1177564	2	Plug, round (120V models)
	1170424	2	Fuse holder (208/240V models)
23	1170425	2	Fuse, 12 amp #LP-CC-12 low peak (208/240V models only)
*	1181996	1	Temperature probe

* not shown on drawing.

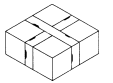

Control Panel Parts for Models with Programmable Controls (PC Models)

See parts list on previous page.

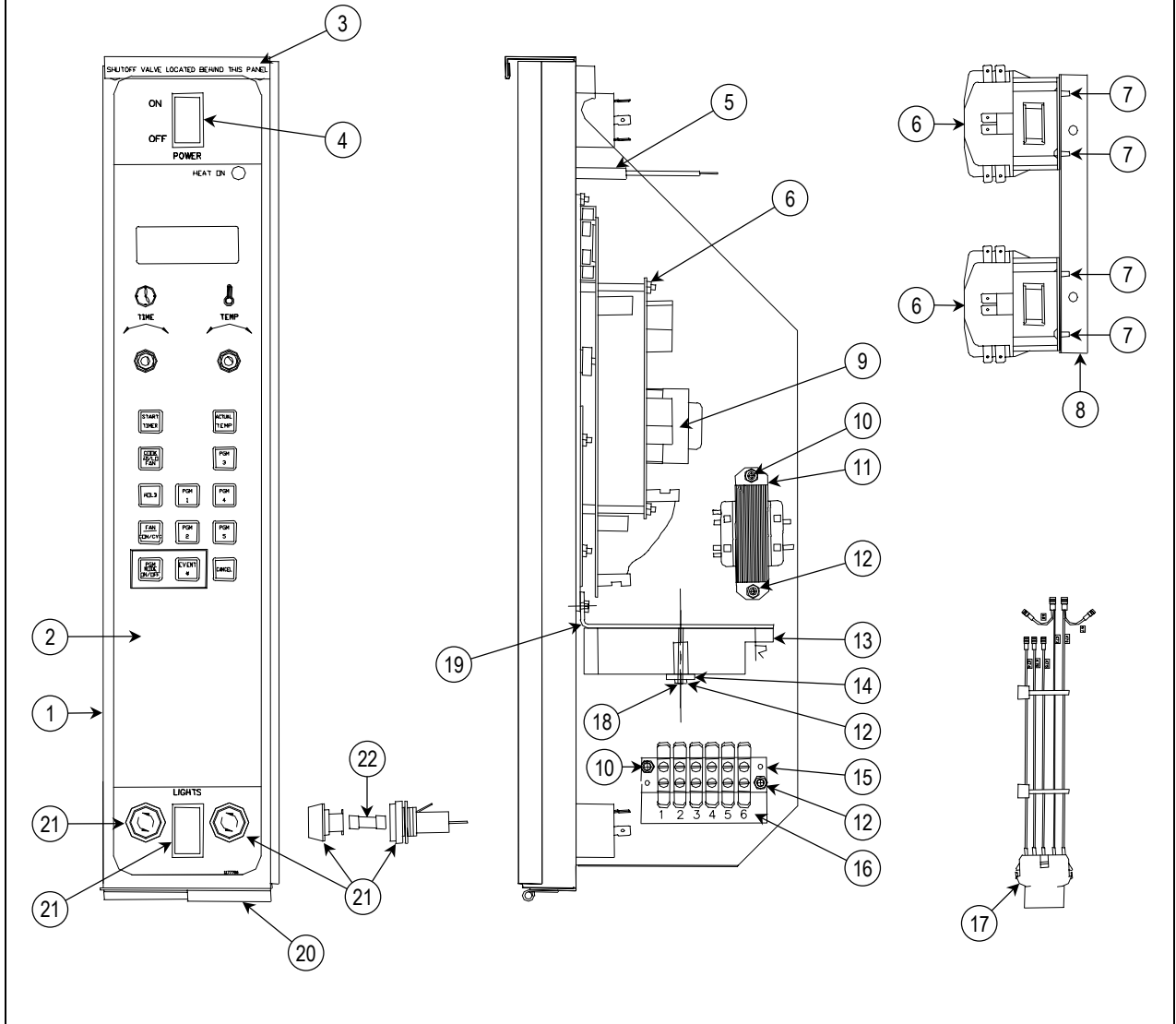



Control Panel Parts for Models with Rack Timer Controls (RT Models)

See drawing on following page.

Key	Part Number	Qty	Description
1-22	1179647	1	Control panel assembly, RT, M-Gold, 120V (assembled, w/o wiring harness)
1-23	1179648	1	Control panel assembly, RT, M-Gold, 208/240V (assembled, w/o wiring harness)
*	1179628	1	Wiring harness, RT, 120V (includes terminal block 1170335)
	1179634	1	Wiring harness, RT, 208/240V (includes terminal block 1170335)
1	1179706	1	Digital control panel weld asm
2	1177787	1	Polypanel, rack timer control
3	1177598	1	Valve location label
4	1177541	1	Rocker switch-DPST- (on-off)
5	1177565	1	Light, (amber) 24V
6	1161449	2	Contactora, two pole, 120V
	1161525	2	Contactora, two pole, 240V
7	1146399	4	Screw #10x1/2 Phillips truss (blunt)
8	1175742	1	Mount, motor contactor
9	1173402	1	Rack timer control
10	1146397	4	Screw 8-32 x 5/8 s/steel pan head
11	1172277	1	Transformer, 120/208/240-24
12	6600430	8	Locknut 8-32
13	1175723	1	Ignition control module 24VAC
14	1177515	1	Clamp, RAM module
15	1170335	1	Terminal block
16	1170336	1	Marker strip
17	1179702	1	Harness, contactor PC/RT
18	1146362	2	Screw 8-32 x 1-5/8 lg. Phillips truss hd
19	1179629	1	RAM mounting bracket
20	1175046	1	Left control panel hinge
21	1177789	1	Rocker switch-SPST momentary
22	1177564	2	Plug, round (120V models)
	1170424	2	Fuse holder (208/240V models)
23	1170425	2	Fuse, 12 amp #LP-CC-12 low peak (208/240V models only)
*	1181996	1	Temperature probe
* not shown on drawing.			

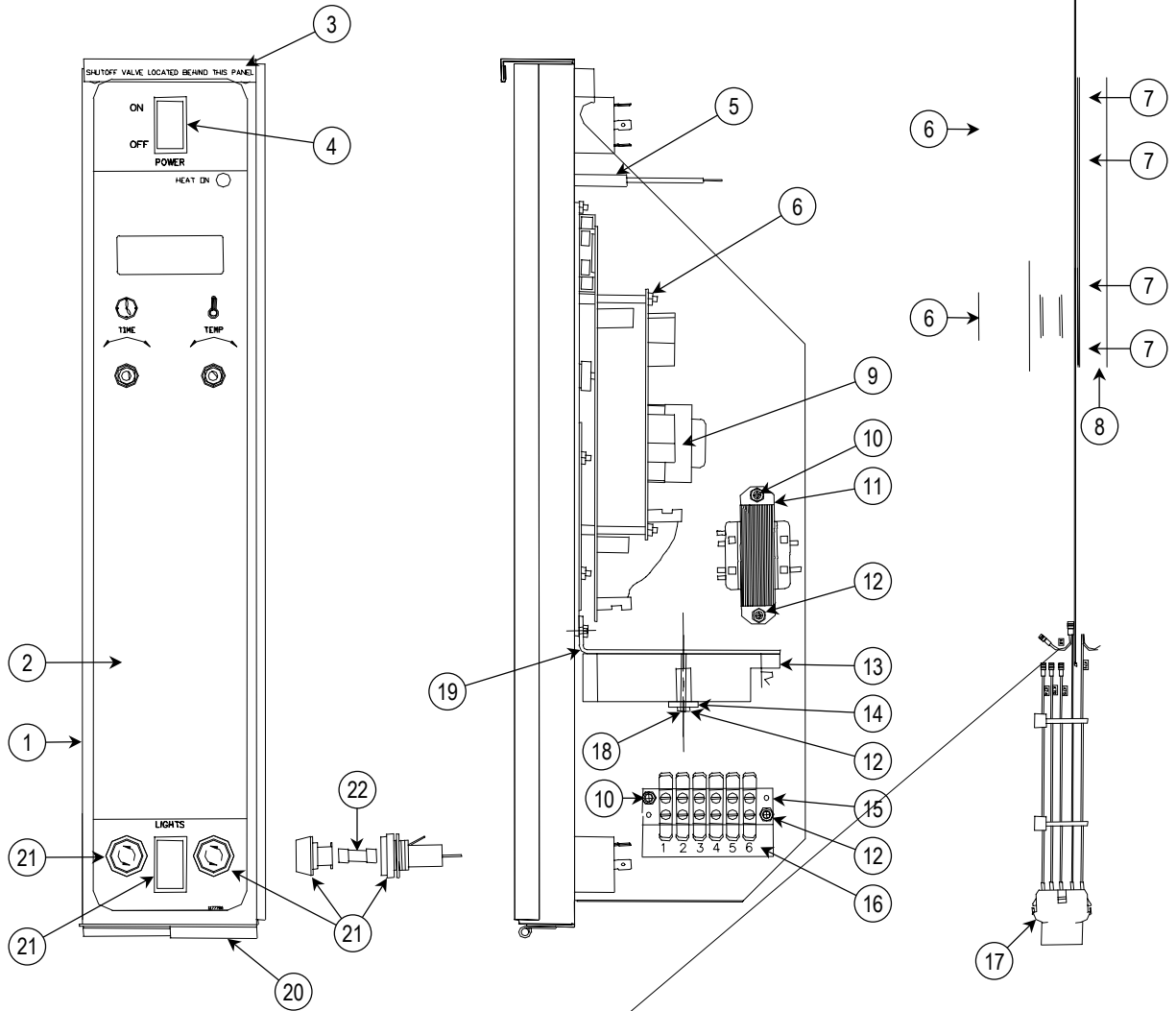
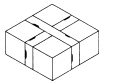

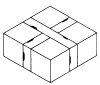

Internal Gas Supply Parts

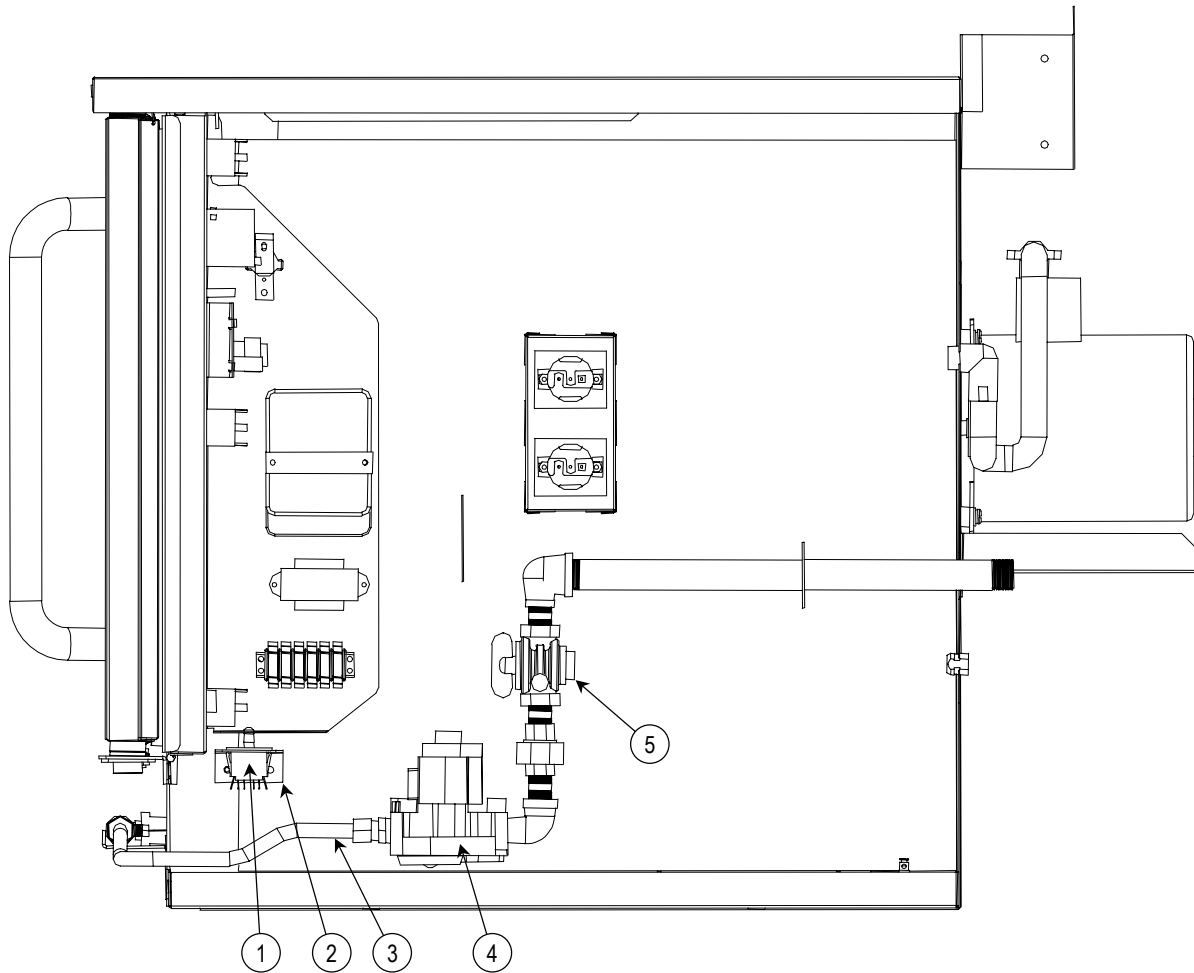

Key	Part Number	Qty	Description
1	1177566	1	Switch, shutdown, SPDT, 15 amp
2	1177495	1	Bracket, shutdown switch mtg.
3	1181934	1	Tube, gas supply, gas, co
4	1175016	1	Valve, nat gas, g-co
	1175375	1	Valve, propane gas, g-co
5	1-5771	1	Valve, shut off, 1/2"

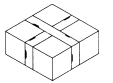

Burner Compartment Parts

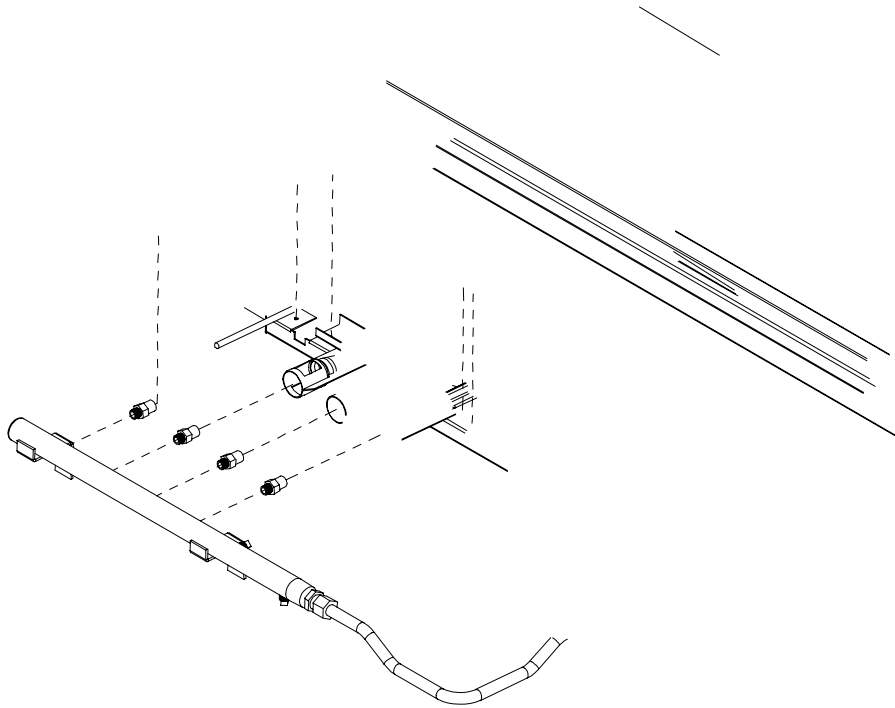

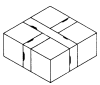

Oven Interior and Fan Motor Parts

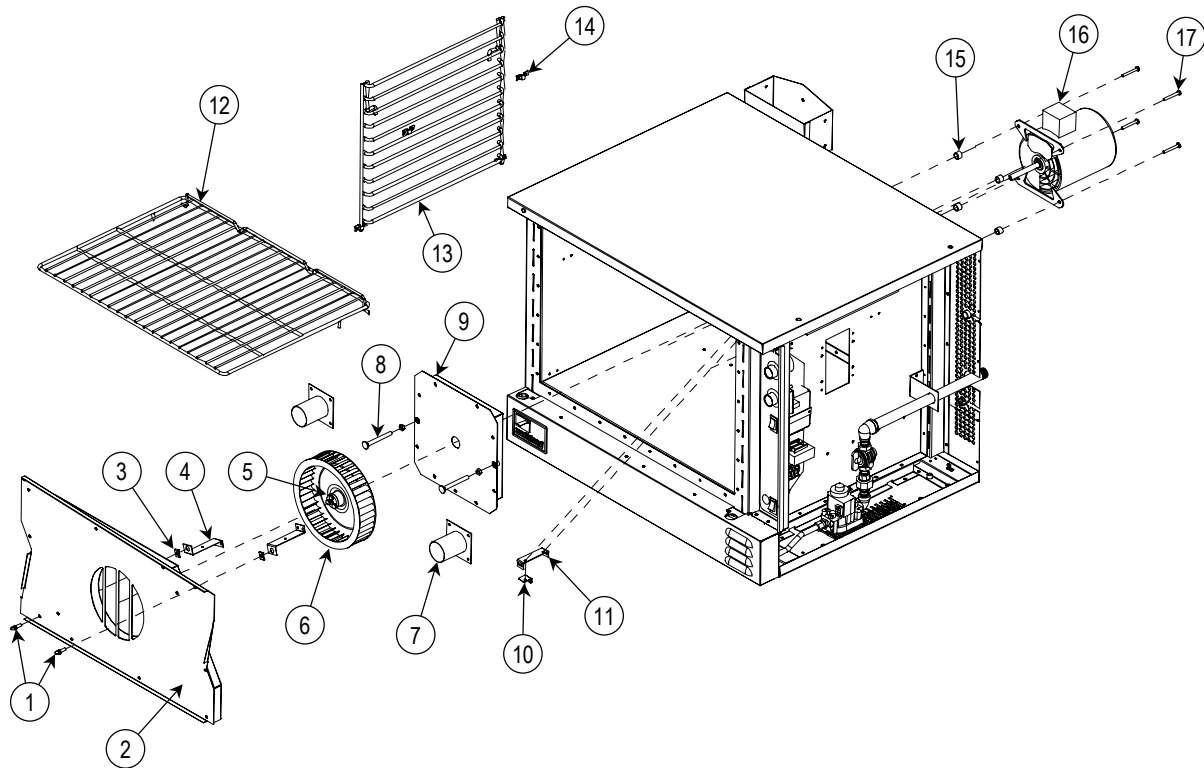

Key	Part Number	Qty	Description
1	1160289	2	Thumb screw 1/4-20 x 3/4
2	1179225	1	Baffle, air. s/a, enamel
3	1166819	2	Nut, 1/4 x 20, speed
4	1175572	2	Bracket, baffle, ctg, G-series
5	1179100	1	Puller disk
6	1179104	1	Blower wheel single
7	1179199	2	Tube asm. outer combustion
8	1175146	2	Bolt, carriage, 3/8 x 3.5", ss
9	1175695	1	Pocket weld asm. blower motor
10	1171710	1	Probe bracket clamp (units built after September 30, 2000, do NOT have this part)
11	1170328	1	Probe bracket (units built after September 30, 2000, do NOT have this part)
12	1175440	5	Rack, oven, shallow, mg
	1175441	5	Rack, oven, bakery, mg
13	1181813	2	Rack guide, 11 pos, shallow
	1181827	2	Rack guide, 11 pos, bakery
14	6660	8	Clip, side rack support
15	1179710	4	Spacer, blower motor
16	1175567	1	Motor, 2sp, 120V, 50/60 cycle
	1175568	1	Motor, 2sp, 240V, 50/60 cycle
17	1146264	4	Screw, 1/4-20 x 2

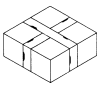

Leg Parts for Single-Deck SilverStar Models

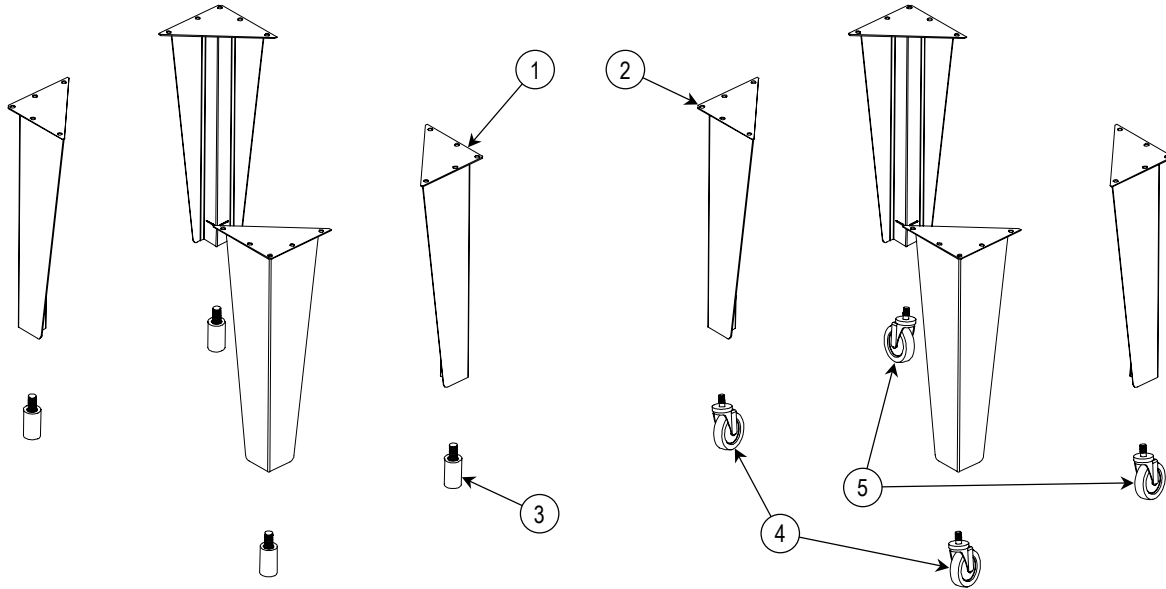
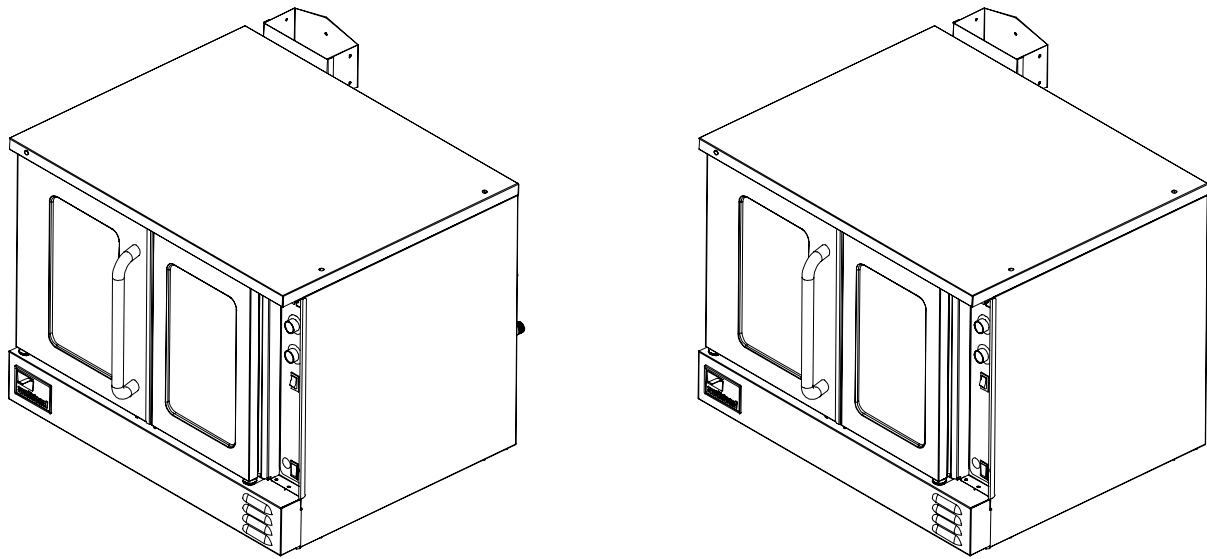

Key	Part Number	Qty	Description
1	1177849	4	Single deck leg, SilverStar (for legs with feet)
2	1177850	4	Single deck leg, SilverStar (for legs with casters)
3	1174266	4	Adjustable foot for leg
*	1173584	4	Flanged foot (optional replacement for adjustable foot 1174266)
4	1174264	2	Caster with brake
5	1174263	2	Caster without brake
*	1174265	1	Set of four casters (two with brake, two without brake)
*	1146213	20	3/8 x 16 x 1 hex head bolt
*	1146513	20	3/8 lock washer
*	1146522	20	3/8 flat washer

* not shown on drawing.

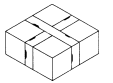

Leg Parts for Single-Deck Marathoner Gold Models

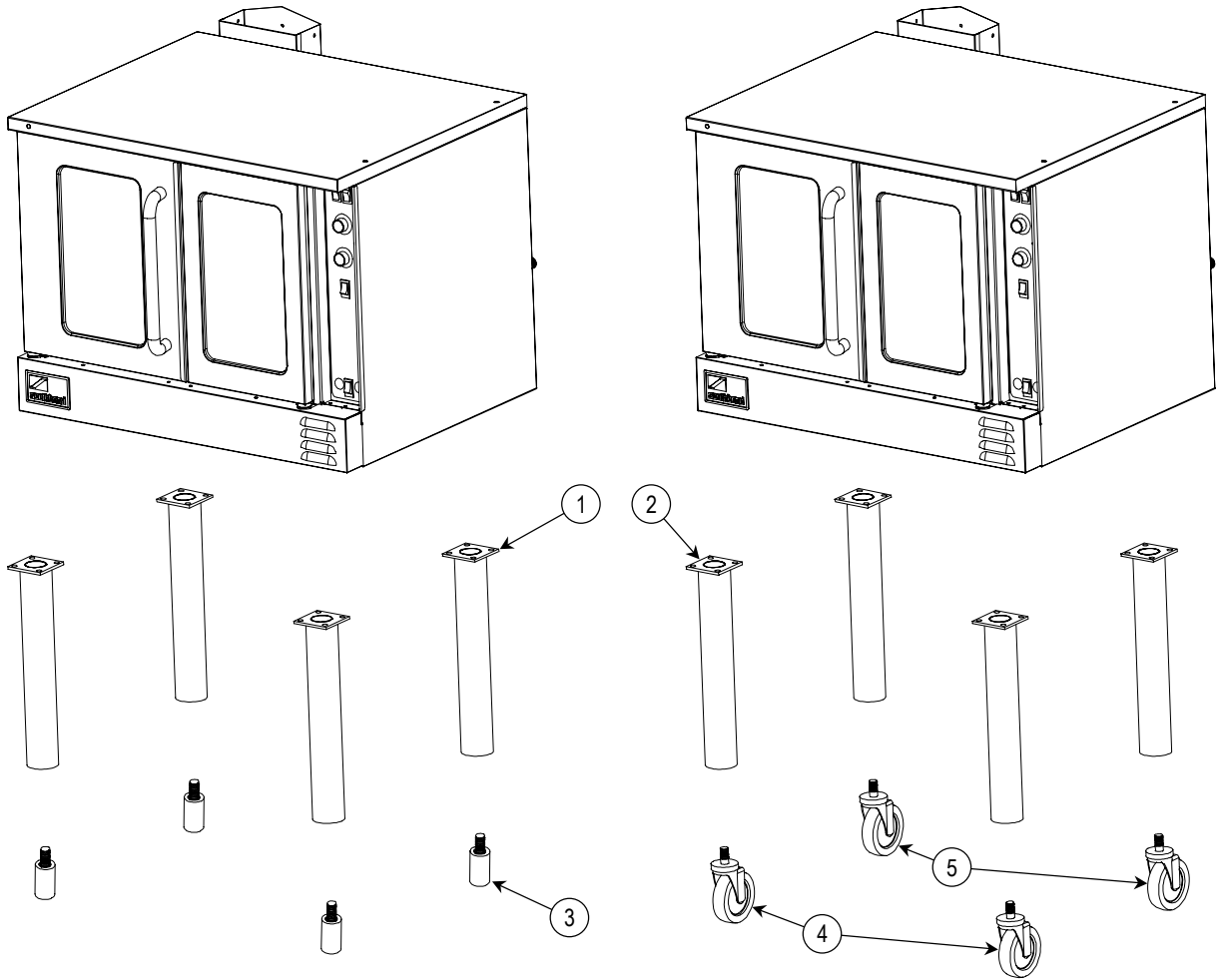

Key	Part Number	Qty	Description
1	1175090	4	Single deck leg, M-Gold (for legs with feet)
2	1175089	4	Single deck leg, M-Gold (for legs with casters)
3	1174266	4	Adjustable foot for leg
*	1173584	4	Flanged foot (optional replacement for adjustable foot 1174266)
4	1174264	2	Caster with brake
5	1174263	2	Caster without brake
*	1174265	1	Set of four casters (two with brake, two without brake)
*	1146213	16	3/8 x 16 x 1 hex head bolt
*	1146513	16	3/8 lock washer
*	1146522	16	3/8 flat washer

* not shown on drawing.

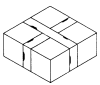

Storage Rack Parts

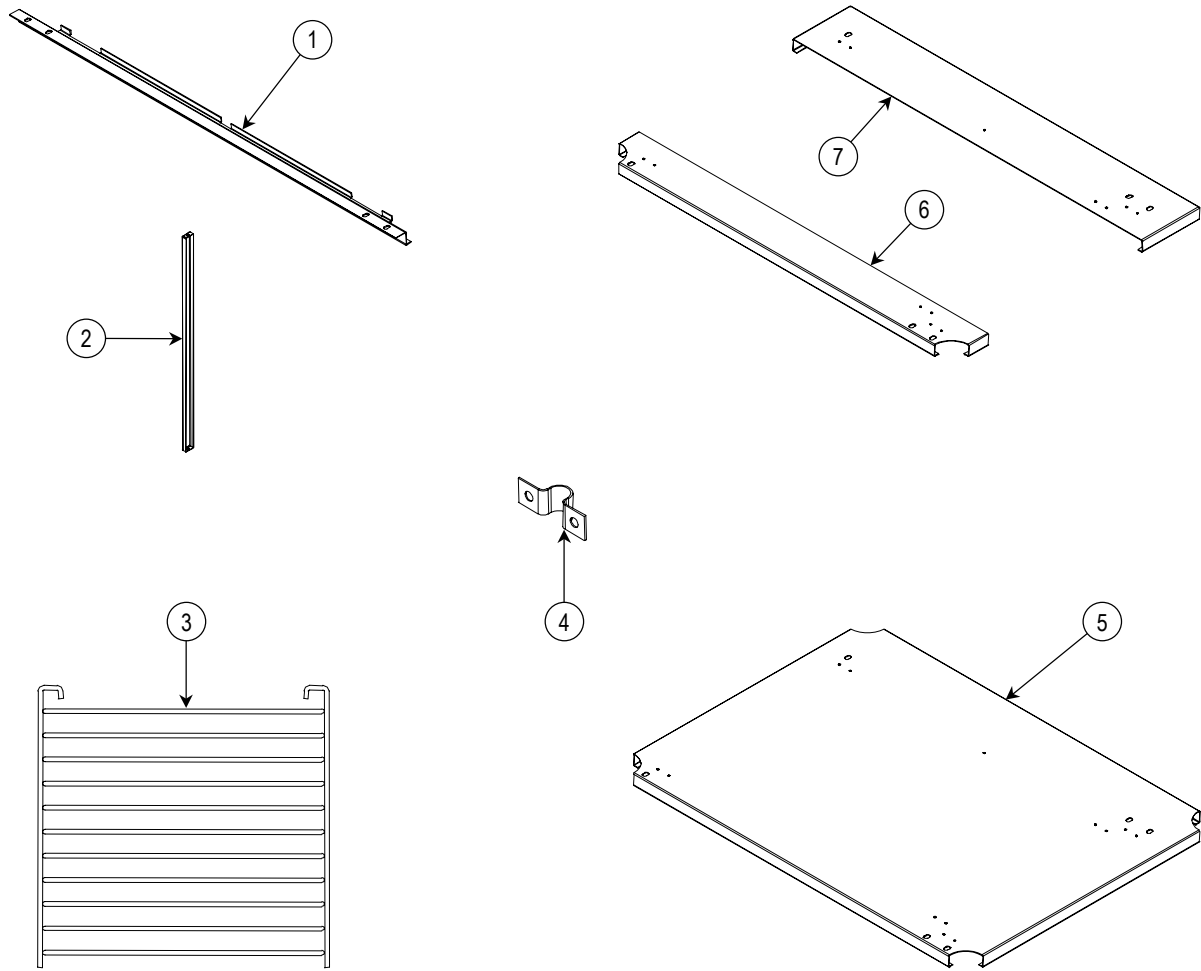

Key	Part Number	Qty	Description
1-7	1175506	1	Cooling rack kit, with shelf, shallow depth
	1175507	1	Cooling rack kit, with shelf, bakery depth
	1175508	1	Cooling rack kit, w/o shelf, shallow depth
	1175509	1	Cooling rack kit, w/o shelf, bakery depth
1	1175296	2	Rack hanger, G/E ser co
2	1175514	1	Stop channel
3	1175438	2	Rack guide, 11 pos. shallow
	1175439	2	Rack guide, 11 pos. bakery
4	6660	8	Clip, side rack support
5	1175294	1	Shelf, open rack, shallow
	1175295	1	Shelf, open rack, bakery
6	1175504	1	Front channel frame
7	1175505	1	Rear channel frame
*	1146304	18	10 x 1/2 Phillips screw
* not shown on drawing.			

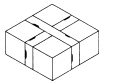

Double-Deck Oven Stacking Parts

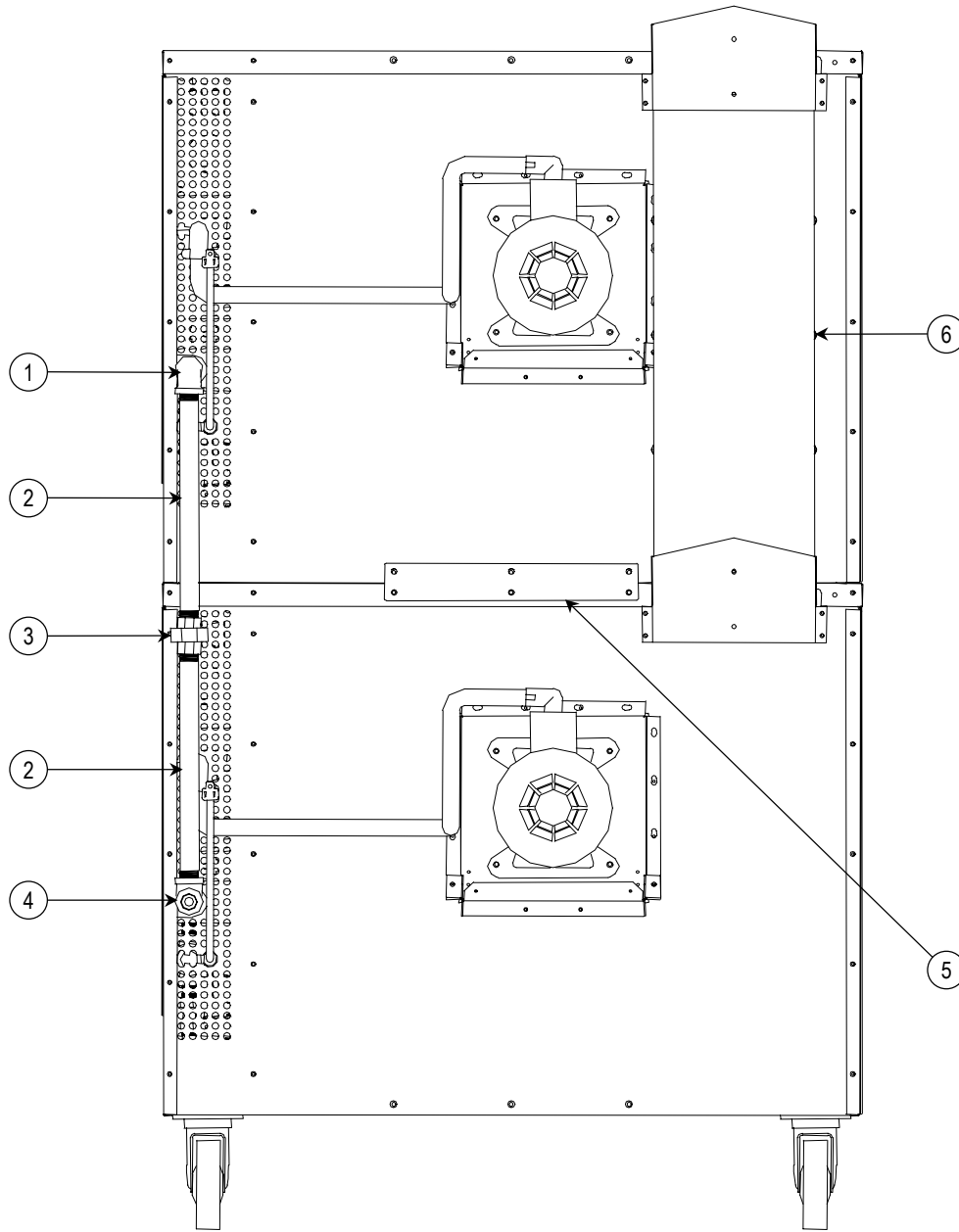

Key	Part Number	Qty	Description
1	1146904	1	3/4" elbow
2	1175149	2	3/4" x 13-1/4" pipe
3	P-5239-5	1	3/4" union
4	1147304	1	3/4" tee pipe
5	1175085	1	Tie bracket
6	1181840	1	Flue box
*	1146213	2	Bolts

* not shown on drawing.

PARTS

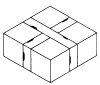

Leg Parts for Double-Deck Ovens

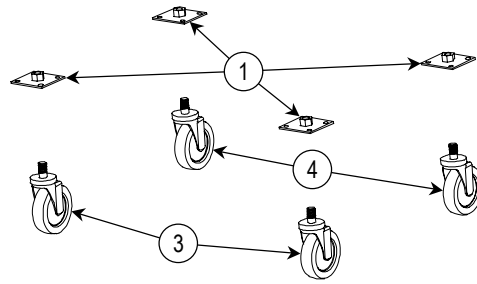
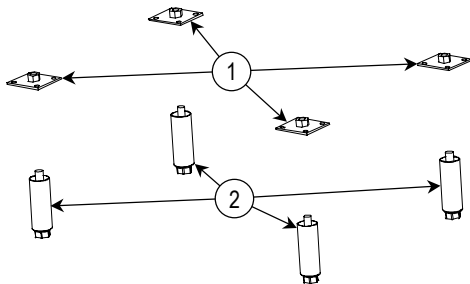
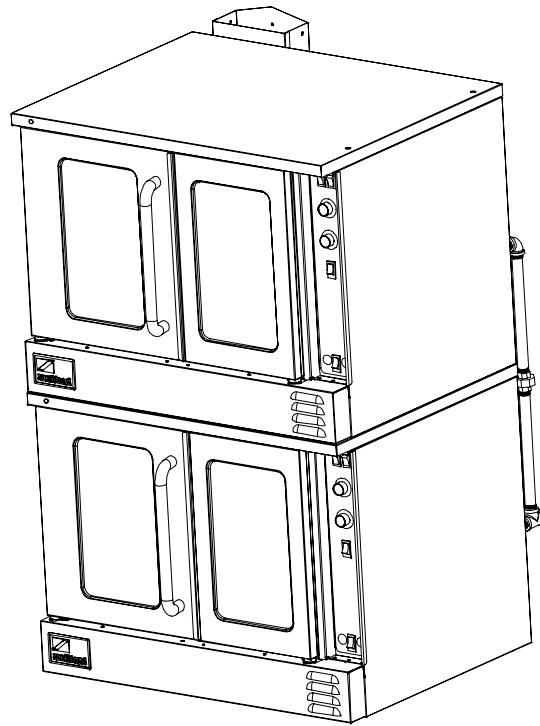
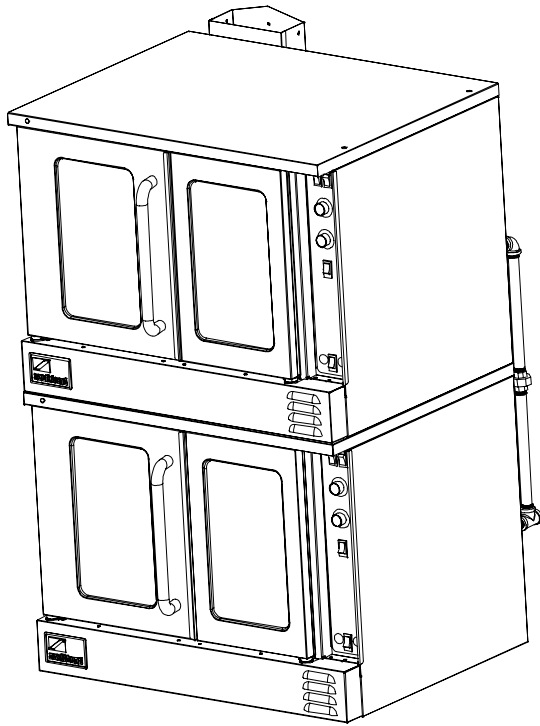

Key	Part Number	Qty	Description
1	1172788	4	Leg pad
2	1174259	4	SS leg, 3/4" stud
*	1174260	1	Leg package (set of four legs only)
3	1174264	2	Caster with brake
4	1174263	2	Caster without brake
*	1174265	1	Set of four casters (two with brake, two without brake)
*	1146213	16	3/8 x 16 x 1 hex head bolt
*	1146513	16	3/8 lock washer
*	1146522	16	3/8 flat washer

* not shown on drawing.

MARATHONER GOLD & SILVERSTAR GAS CONVECTION OVENS

Notes:

Notes:

Marathoner Gold & SilverStar GAS CONVECTION OVENS

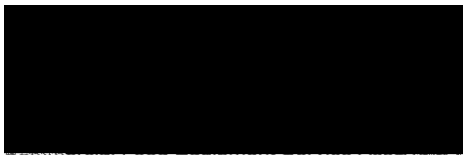

A product with the Southbend name incorporates the best in durability and low maintenance. We all recognize, however, that replacement parts and occasional professional service may be necessary to extend the useful life of this unit. When service is needed, contact a Southbend Authorized Service Agency, or your dealer. To avoid confusion, always refer to the model number, serial number, and type of your unit.



Southbend
1100 Old Honeycutt Road, Fuquay-Varina, NC 27526
(800) 348-2558 or (919) 552-9161 • FAX (800) 348-2558 or (919) 552-9798
www.southbendnc.com

Free Manuals Download Website

<http://myh66.com>

<http://usermanuals.us>

<http://www.somanuals.com>

<http://www.4manuals.cc>

<http://www.manual-lib.com>

<http://www.404manual.com>

<http://www.luxmanual.com>

<http://aubethermostatmanual.com>

Golf course search by state

<http://golfingnear.com>

Email search by domain

<http://emailbydomain.com>

Auto manuals search

<http://auto.somanuals.com>

TV manuals search

<http://tv.somanuals.com>