

**STAMINA**|X  
EXTREME TRAINING SERIES

# Hyper Bench

## Owner's Manual

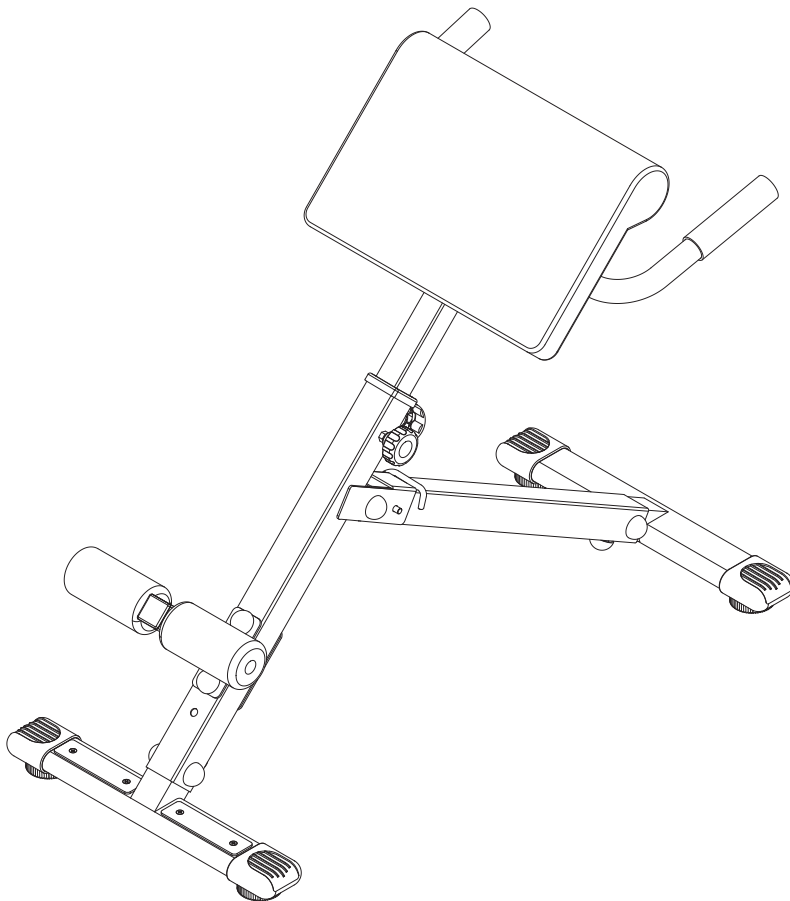

Product May Vary Slightly From Pictured.

**CAUTION:**

Weight on this product should not exceed 250 lbs.

**⚠ WARNING**

Exercise can present a health risk. Consult a physician before beginning any exercise program with this equipment. If you feel faint or dizzy, immediately discontinue use of this equipment. Serious bodily injury can occur if this equipment is not assembled and used correctly. Serious bodily injury can also occur if all instructions are not followed. Keep others and pets away from equipment when in use. Always make sure all bolts and nuts are securely tightened prior to each use. Follow all safety instructions in this manual.

When calling for parts or service, please specify the following number:

**Model#: 20-2015**

This Product is Distributed Exclusively by



2040 N. Alliance, Springfield, MO 65803

Customer Service

1 (800) 375-7520

[www.staminaproducts.com](http://www.staminaproducts.com)

**STAMINA PRODUCTS**  
MADE IN CHINA

© 2012 Stamina Products, Inc.  
2012, 08

## TABLE OF CONTENTS

Safety Instructions .....	2	Conditioning Guidelines .....	12
Before You Begin .....	4	Warm-Up and Cool-Down .....	13
Equipment Warning, Caution & Notice Labels ...	5	Product Parts Drawing .....	14
Hardware Identification Chart .....	6	Parts List .....	15
Assembly Instructions .....	7	Warranty .....	16
Operational Instructions .....	10	Notes .....	17
Maintenance .....	11	Fax/Mail Ordering Form .....	18
Storage .....	11		

## SAFETY INSTRUCTIONS

- ⚠ WARNING** This product contains a chemical known to the State of California to cause cancer and birth defects or other reproductive harm.
- ⚠ CAUTION** Consult your physician before starting this or any exercise program. This is especially important if you are over the age of 35, have never exercised before, are pregnant, or suffer from any health problem. This product is for home use only. Do not use in institutional or commercial applications. Failure to follow all warnings and instructions could result in bodily injury and property damage.
- ⚠ WARNING** To reduce the risk of serious injury, read the following Safety Instructions before using the **STAMINA|X-Hyper Bench**.

1. Read all warnings and cautions posted on the **STAMINA|X-Hyper Bench**.
2. The **STAMINA|X-Hyper Bench** should only be used after a thorough review of the Owner's Manual.
3. We recommend that two people be available for assembly of this product.
4. Keep children away from the **STAMINA|X-Hyper Bench**. Do not allow children to use or play on the **STAMINA|X-Hyper Bench**. Keep children and pets away from the **STAMINA|X-Hyper Bench** when it is in use.
5. It is recommended that you place this exercise equipment on an equipment mat.
6. Set up and operate the **STAMINA|X-Hyper Bench** on a solid level surface. Do not position the **STAMINA|X-Hyper Bench** on loose rugs or uneven surfaces.
7. Make sure that adequate space is available for access to and around the **STAMINA|X-Hyper Bench**.
8. Before using, inspect the **STAMINA|X-Hyper Bench** for worn or loose components, and securely tighten or replace any worn or loose components prior to use.
9. Consult a physician prior to commencing an exercise program and follow his/her recommendations in developing your fitness program. If at any time during exercise you feel faint, dizzy, or experience pain, stop and consult your physician.
10. Always choose the workout which best fits your physical strength and flexibility level. Know your limits and train within them. Always use common sense when exercising.
11. Do not wear loose or dangling clothing while using the **STAMINA|X-Hyper Bench**.
12. Never exercise in bare feet or socks; always wear proper footwear such as running, walking, or cross training shoes that fit well, provide foot support, and feature non-skid rubber soles.
13. Be careful to maintain your balance while using, mounting, dismounting, or assembling the **STAMINA|X-Hyper Bench**, loss of balance may result in a fall and serious bodily injury.
14. The **STAMINA|X-Hyper Bench** should not be used by persons weighing over 250 pounds.
15. The **STAMINA|X-Hyper Bench** should be used by only one person at a time.
16. The **STAMINA|X-Hyper Bench** is for consumer use only. It is not for use in public or semipublic facilities.

# Call Us First



**Customer Service**  
**1 (800) 375-7520**  
**www.staminaproducts.com**

## THANK YOU FOR PURCHASING THE STAMINA|X-Hyper Bench

To enact your warranty, please register your product  
by going to [register.staminaproducts.com](http://register.staminaproducts.com)

Your STAMINA|X-Hyper Bench does require assembly.  
Please follow the assembly steps set forth in this manual.  
With regular workouts, you will be getting your body into shape  
and be on your way to achieving a happier and healthier lifestyle.

Should you have any questions,  
please call our Customer Service Department toll-free number,  
**1 (800) 375-7520**

Monday - Thursday, 7:30 A.M. - 5:00 P.M., Central Time.  
Friday, 8:00 A.M. - 3:00 P.M., Central Time.



**ONLINE**  
CUSTOMER SERVICE  
[customerservice@staminaproducts.com](mailto:customerservice@staminaproducts.com)  
[www.staminaproducts.com](http://www.staminaproducts.com)



**TELEPHONE**  
CUSTOMER SERVICE  
Tel: 1 (800) 375-7520



**FAX**  
CUSTOMER SERVICE  
Fax: (417) 889-8064



**MAIL**  
STAMINA PRODUCTS, INC.  
ATTN: Customer Service  
P.O. Box 1071  
Springfield, MO. 65801-1071



## BEFORE YOU BEGIN

Thank you for choosing the **STAMINA|X-Hyper Bench**. We take great pride in producing this quality product and hope it will provide many hours of quality exercise to make you feel better, look better, and enjoy life to its fullest.

It's a proven fact that a regular exercise program can improve your physical and mental health. Too often, our busy lifestyles limit our time and opportunity to exercise. The **STAMINA|X-Hyper Bench** provides a convenient and simple method to begin your journey of getting your body in shape and achieving a happier and healthier lifestyle.

Before reading further, please review the drawing below and familiarize yourself with the parts that are labeled.

Read this manual carefully before using the **STAMINA|X-Hyper Bench**.

Although Stamina constructs its products with the finest materials and uses the highest standards of manufacturing and quality control, there can sometimes be missing parts or incorrectly sized parts. If you have any questions or problems with the parts included with your **STAMINA|X-Hyper Bench**, please do not return the product. Contact us **FIRST!**

If a part is missing or defective, please go to [staminaproducts.com](http://staminaproducts.com) under the Service section and order the part needed, or call us toll free at 1-800-375-7520 (in the U.S.). Our Customer Service Staff is available to assist you from 7:30 A.M. to 5:00 P.M. (Central Time) Monday through Thursday and 8:00 A.M. to 3:00 P.M. (Central Time) on Friday.

Be sure to have the name and model number of the product available when you contact us.

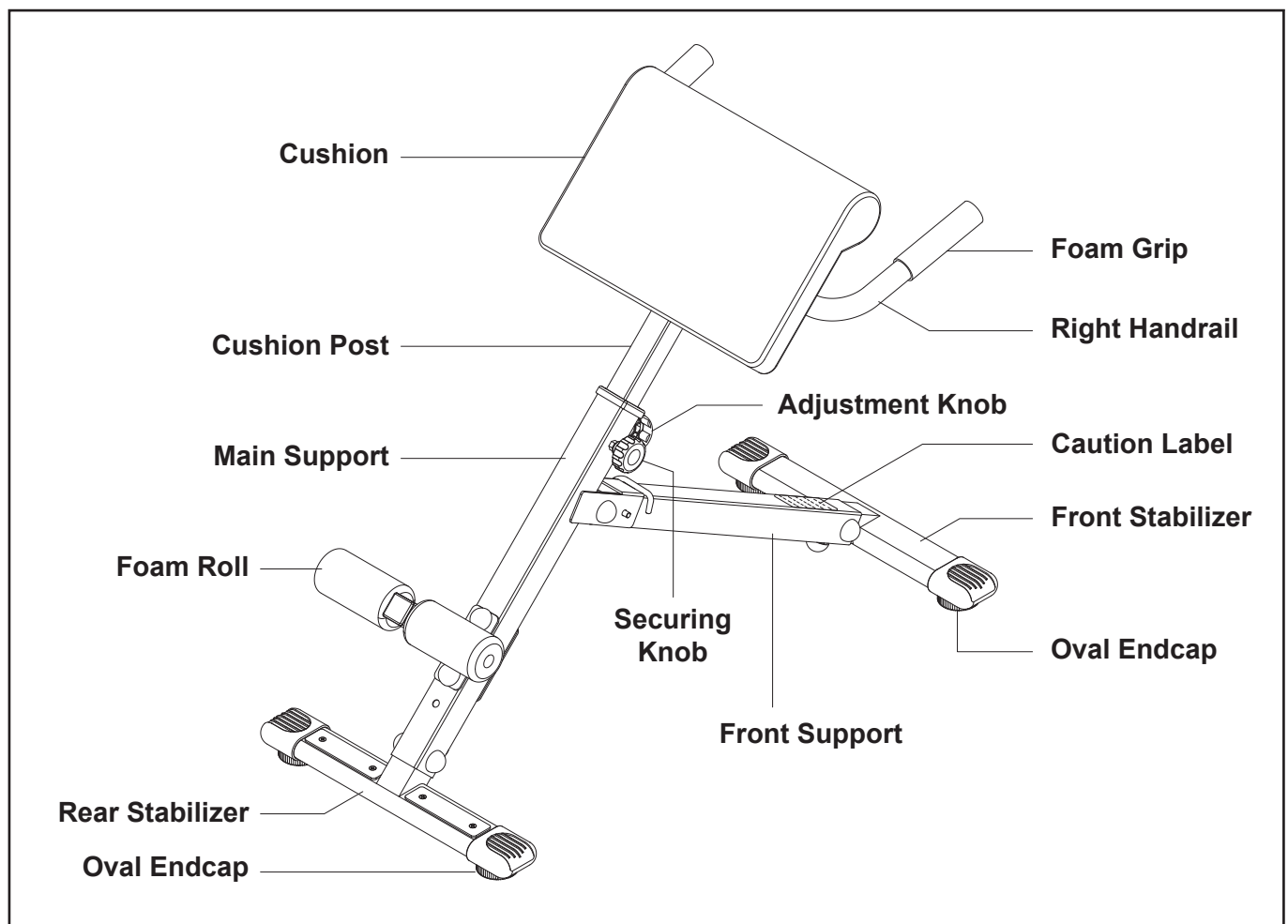

THE FOLLOWING TOOLS ARE INCLUDED FOR ASSEMBLY:



Wrench (2 pieces)

## EQUIPMENT WARNING, CAUTION & NOTICE LABELS

This chart is provided to help identify the warning, caution, and notice labels on the **STAMINA|X - Hyper Bench**. Please take a moment to familiarize yourself with all of the warning, caution, and notice labels.

Label is larger than actual size

### **C1** CAUTION LABEL(33)



# HARDWARE IDENTIFICATION CHART

This chart is provided to help identify the hardware used in the assembly process. Place the washers or the ends of the bolts or screws on the circles to check for the correct diameter. Use the small scale to check the length of the bolts and screws.

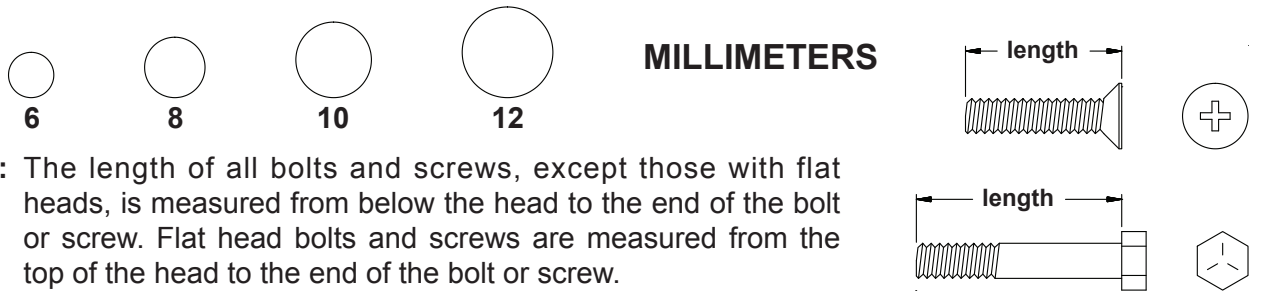
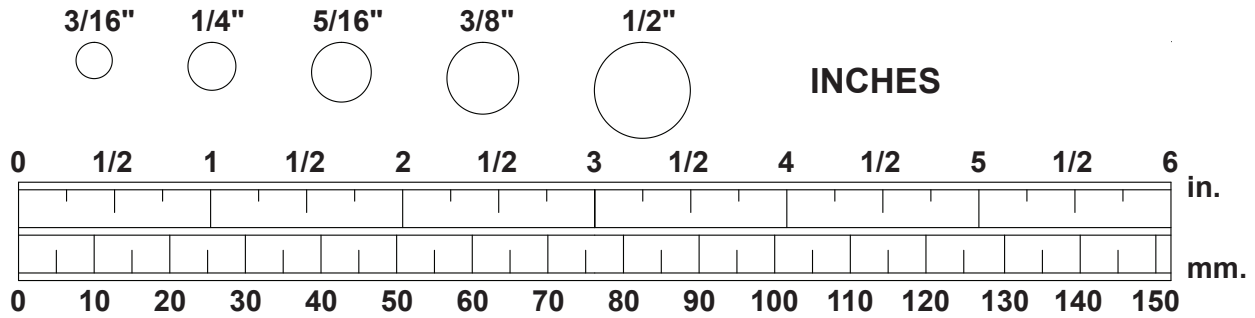

**NOTICE:** The length of all bolts and screws, except those with flat heads, is measured from below the head to the end of the bolt or screw. Flat head bolts and screws are measured from the top of the head to the end of the bolt or screw.

After unpacking the unit, open the hardware bag and make sure that you have all the following items. Some hardware may be already attached to the part.

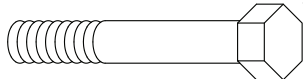
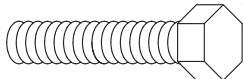
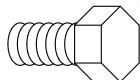
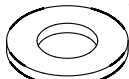
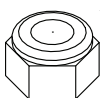
	Part Number and Description	Qty
	18 Bolt, Hex Head (M10 x 1.5 x 70mm)	3
	19 Bolt, Hex Head (M10 x 1.5 x 60mm)	2
	20 Bolt, Hex Head (M10 x 1.5 x 20mm)	6
	21 Bolt, Hex Head (M6 x 1 x 15mm)	4
	23 Washer (M10)	16
	24 Washer (M6)	4
	25 Nylock Nut (M10 x 1.5)	5

## ASSEMBLY INSTRUCTIONS

Place all parts from the box in a cleared area and position them on the floor in front of you. Remove all packing materials from your area and place them back into the box. Do not dispose of the packing materials until assembly is completed. Read each step carefully before beginning. If you are missing a part, please go to [staminaproducts.com](http://staminaproducts.com) under the Service section and order the part needed, e-mail us at [customerservice@staminaproducts.com](mailto:customerservice@staminaproducts.com), or call us toll free at 1-800-375-7520 (in the U.S.). Our Customer Service Staff is available to assist you from 7:30 A.M. to 5:00 P.M. (Central Time) Monday through Thursday and 8:00 A.M. to 3:00 P.M. (Central Time) on Friday.

### STEP 1

Insert the **REAR STABILIZER(1)** into the **MAIN SUPPORT(3)** and secure with **HEX BOLTS(M10x1.5x20mm)(20)**, and **WASHERS(M10)(23)**. Press a **NUT CAP(M10)(26)** onto each bolt head of **HEX BOLTS (M10x1.5x20mm)(20)**.

### STEP 2

Insert the **FRONT STABILIZER(2)** into the **FRONT SUPPORT(4)** and secure with **HEX BOLTS(M10x1.5x20mm)(20)**, and **WASHERS(M10)(23)**. Press a **NUT CAP(M10)(26)** onto each bolt head of **HEX BOLTS (M10x1.5x20mm)(20)**.

### STEP 3

Attach the **FRONT SUPPORT(4)** to the **MAIN SUPPORT(3)** with **HEX BOLT(M10x1.5x70mm)(18)**, **WASHERS(M10)(23)**, and **NYLOCK NUT(M10x1.5)(25)**. Press the **NUT CAPS(M10)(26)** onto the bolt head of **HEX BOLT(M10x1.5x70mm)(18)** and **NYLOCK NUT(M10x1.5)(25)**. Lock the **FRONT SUPPORT(4)** in position by inserting the **LOCKING PIN(15)** through the bracket on the **MAIN SUPPORT(3)** and the **FRONT SUPPORT(4)**.

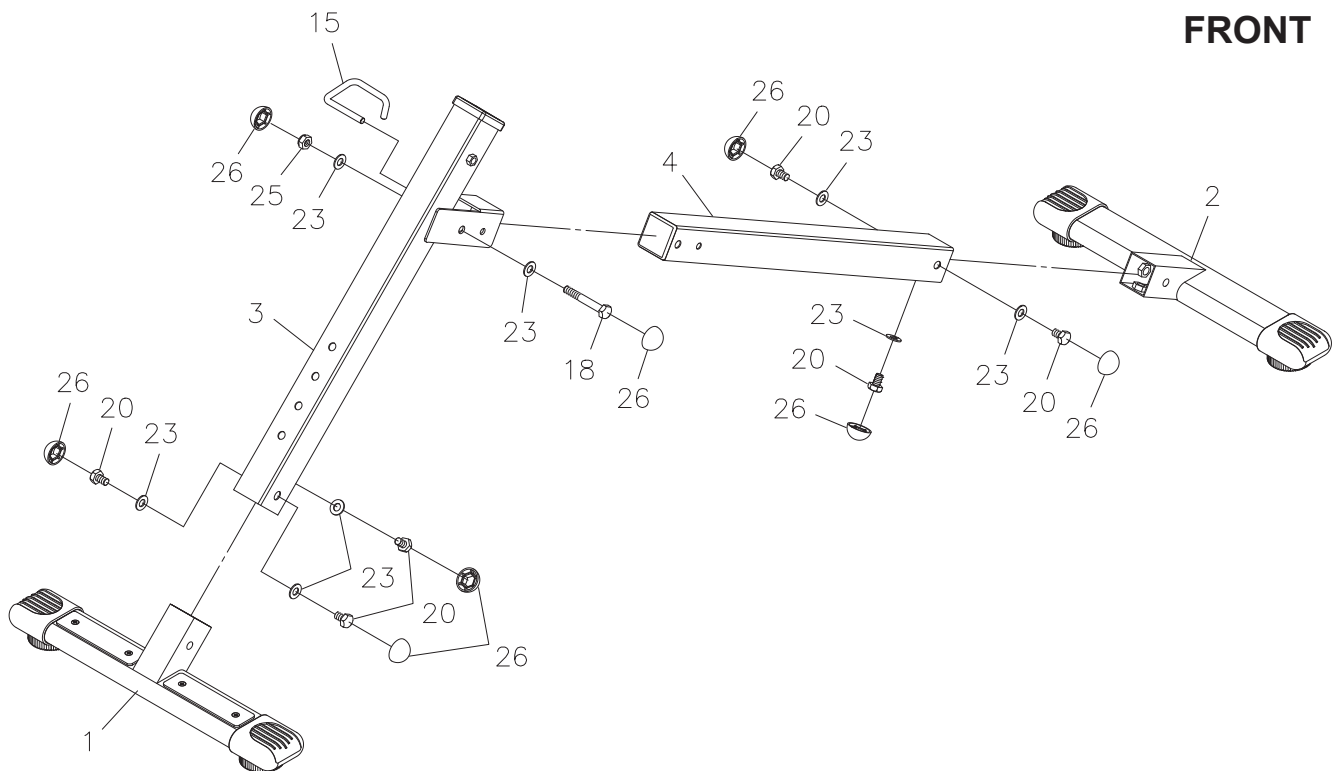

**REAR**

## ASSEMBLY INSTRUCTIONS

### STEP 4

**NOTE:** There are two sets of holes in the **MAIN SUPPORT(3)** which allows you to attach the **FOAM ROLL POST(8)** to two different positions. Try the upper position first.

Attach the **FOAM ROLL POST(8)** to the **MAIN SUPPORT(3)** with the **SUPPORT PLATE(11)**, **HEX BOLTS (M10x1.5x70mm)(18)**, **WASHERS(M10)(23)**, and **NYLOCK NUTS(M10x1.5)(25)**. Press the **NUT CAPS(M10)(26)** onto the bolt heads of **HEX BOLTS(M10x1.5x70mm)(18)** and **NYLOCK NUTS(M10x1.5)(25)**.

### STEP 5

**NOTE:** There are two adjustment holes in the **FOAM ROLL POST(8)**. These adjustment holes allow users to adjust the position of the **FOAM ROLLS(16)**. Try the upper hole first.

Slide a **FOAM ROLL(16)** onto the **SUPPORT TUBE(9)**. Insert the other end of the **SUPPORT TUBE(9)** through the upper hole in the **FOAM ROLL POST(8)**. Slide another **FOAM ROLL(16)** over the protruding end of the **SUPPORT TUBE(9)**.

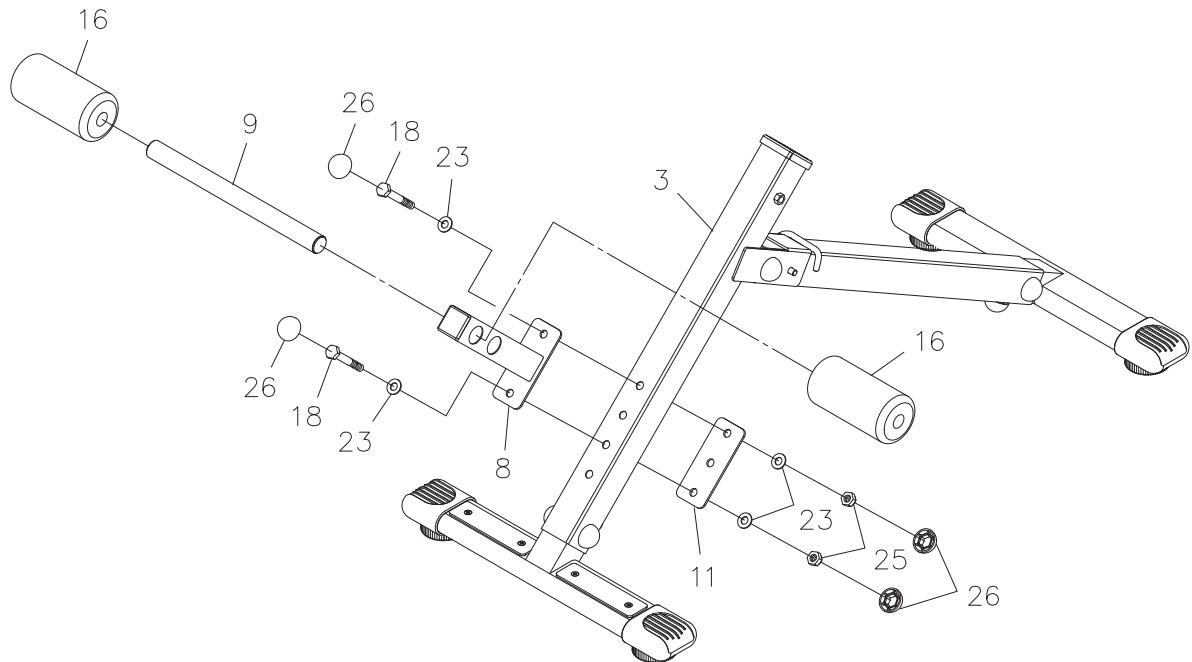



## ASSEMBLY INSTRUCTIONS

### STEP 6

Insert the **CUSHION POST(5)** into **MAIN SUPPORT(3)** and lock in position with the **ADJUSTMENT KNOB(13)**. For added safety, thread the **SECURING KNOB(14)** into the right side of the **MAIN SUPPORT(3)**.  
**NOTE:** The pin of the **ADJUSTMENT KNOB(13)** must be inserted into one of the adjustment holes in the **CUSHION POST(5)**. The **ADJUSTMENT KNOB(13)** and **SECURING KNOB(14)** must be screwed in tightly to ensure that the **CUSHION POST(5)** will fit securely in the **MAIN SUPPORT(3)**.

### STEP 7

Attach the **LEFT** and **RIGHT HANDRAILS(6, 7)** to both sides of the **CUSHION POST(5)** with **HEX BOLTS(M10x1.5x60mm)(19)**, **WASHERS(M10)(23)**, and **NYLOCK NUTS(M10x1.5)(25)**. Press the **NUT CAPS(M10)(26)** onto the bolt heads of **HEX BOLTS(M10x1.5x60mm)(19)** and **NYLOCK NUTS(M10x1.5)(25)**.

### STEP 8

Attach the **CUSHION(12)** to the **CUSHION POST(5)** with **HEX BOLTS(M6x1x15mm)(21)** and **WASHERS (M6)(24)**.

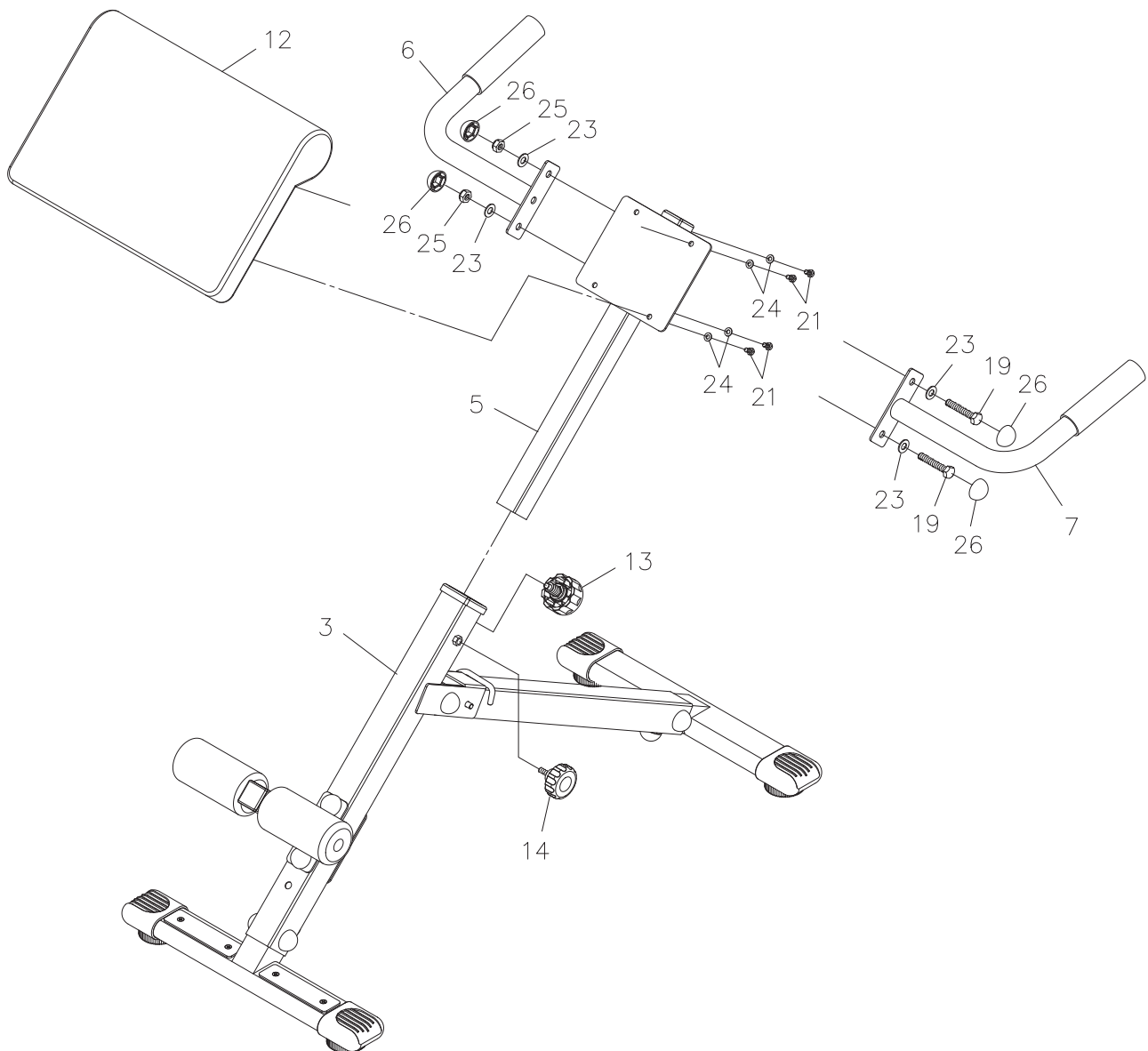

## OPERATIONAL INSTRUCTIONS

### CUSHION HEIGHT ADJUSTMENT

To adjust the height of the **CUSHION(12)**, loosen but do not remove the **SECURING KNOB(14)**. Loosen and pull the **ADJUSTMENT KNOB(13)**, slide the **CUSHION(12)** to the desired position, and secure with the **ADJUSTMENT KNOB(13)**. Tighten the **ADJUSTMENT KNOB(13)** and **SECURING KNOB(14)**.

**NOTE:** The pin of the **ADJUSTMENT KNOB(13)** must be inserted into one of the adjustment holes in the **CUSHION POST(5)**. The **ADJUSTMENT KNOB(13)** and **SECURING KNOB(14)** must be screwed in tightly to ensure that the **CUSHION POST(5)** will fit securely in the **MAIN SUPPORT(3)**.

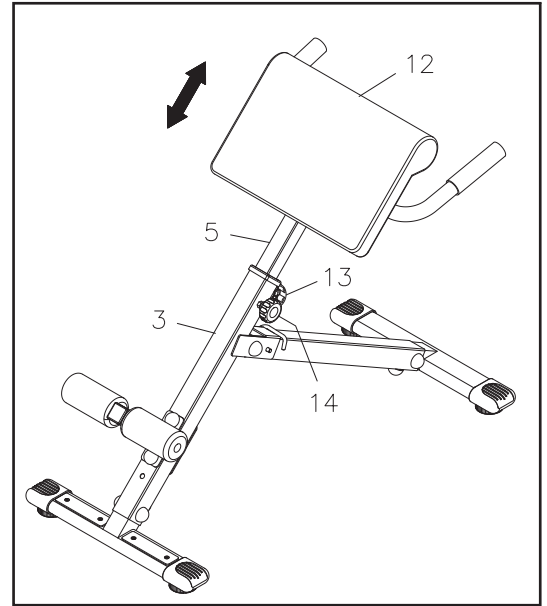

## STORAGE

1. To store the **STAMINA|X-Hyper Bench**, simply keep it in a clean dry place.
2. Use two people to lift from the **LEFT** and **RIGHT HANDRAILS(6, 7)** and **REAR STABILIZER(1)** to move the **STAMINA|X-Hyper Bench**.
3. Follow the process below to fold the **STAMINA|X-Hyper Bench** as illustrated for easy storage.
  - a. Loosen but do not remove the **SECURING KNOB(14)**. Loosen and pull the **ADJUSTMENT KNOB(13)**, slide the **CUSHION(12)** to the lowest position. Then lock in position by tightening the **ADJUSTMENT KNOB(13)** and **SECURING KNOB(14)**.
  - b. Remove the **LOCKING PIN(15)** from the **MAIN SUPPORT(3)** to fold the **FRONT SUPPORT(4)**. Store the **LOCKING PIN(15)** in the hole in the **FRONT SUPPORT(4)**.
  - c. The **STAMINA|X-Hyper Bench** should appear as shown in illustration **B** after folded.

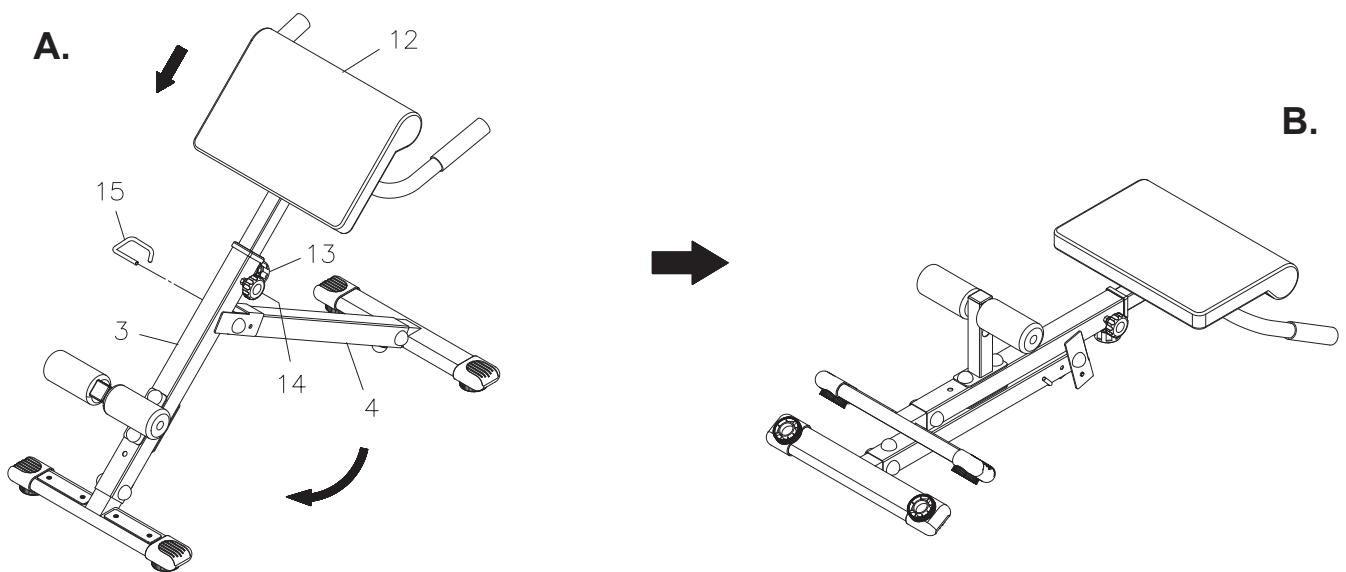

## MAINTENANCE

The safety and integrity designed into the **STAMINA|X-Hyper Bench** can only be maintained when the **STAMINA|X-Hyper Bench** is regularly examined for damage and wear. Special attention should be given to the following:

1. Verify that the **CAUTION LABEL(33)** is in place and easy to read. Call Stamina Products immediately at **1-800-375-7520** for a replacement **CAUTION LABEL(33)** if it is missing or damaged.
2. It is the sole responsibility of the user/owner to ensure that regular maintenance is performed.
3. Verify that all nuts and bolts are present and properly tightened. Replace missing nuts and bolts. Securely tighten loose nuts and bolts.
4. Worn or damaged components shall be replaced immediately or the **STAMINA|X-Hyper Bench** removed from service until repair is made.
5. Only Stamina Products supplied components shall be used to maintain/repair the **STAMINA|X-Hyper Bench**.
6. Keep your **STAMINA|X-Hyper Bench** clean by wiping it off with an absorbent cloth after use.

## CONDITIONING GUIDELINES

How you begin your exercise program depends on your physical condition. If you have been inactive for several years or are severely overweight, start slowly and increase your workout time gradually. Increase your workout intensity gradually by monitoring your heart rate while you exercise.

Remember to follow these essentials:

- Have your doctor review your training and diet programs.
- Begin your training program slowly with realistic goals that have been set by you and your physician.
- Warm up before you exercise and cool down after you work out.
- Take your pulse periodically during your workout and strive to stay within a range of 60% (lower intensity) to 90% (higher intensity) of your maximum heart rate zone. Start at the lower intensity, and build up to higher intensity as you become more aerobically fit.
- If you feel dizzy or lightheaded you should slow down or stop exercising.

Initially you may only be able to exercise within your target zone for a few minutes; however, your aerobic capacity will improve over the next six to eight weeks. It is important to pace yourself while you exercise so you don't tire too quickly.

To determine if you are working out at the correct intensity, use a heart rate monitor or use the table below. For effective aerobic exercise, your heart rate should be maintained at a level between 60% and 90% of your maximum heart rate. If just starting an exercise program, work out at the low end of your target heart rate zone. As your aerobic capacity improves, gradually increase the intensity of your workout by increasing your heart rate.

Measure your heart rate periodically during your workout by stopping the exercise but continuing to move your legs or walk around. Place two or three fingers on your wrist and take a six second heartbeat count. Multiply the results by ten to find your heart rate. For example, if your six second heartbeat count is 14, your heart rate is 140 beats per minute. A six second count is used because your heart rate will drop rapidly when you stop exercising. Adjust the intensity of your exercise until your heart rate is at the proper level.

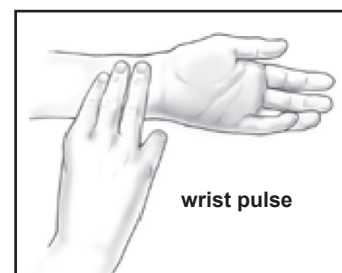

Target Heart Rate Zone Estimated by Age\*

Age	Target Heart Rate Zone (55%-90% of Maximum Heart Rate)	Average Maximum Heart Rate 100%
20 years	110-180 beats per minute	200 beats per minute
25 years	107-175 beats per minute	195 beats per minute
30 years	105-171 beats per minute	190 beats per minute
35 years	102-166 beats per minute	185 beats per minute
40 years	99-162 beats per minute	180 beats per minute
45 years	97-157 beats per minute	175 beats per minute
50 years	94-153 beats per minute	170 beats per minute
55 years	91-148 beats per minute	165 beats per minute
60 years	88-144 beats per minute	160 beats per minute
65 years	85-139 beats per minute	155 beats per minute
70 years	83-135 beats per minute	150 beats per minute

\* For cardiorespiratory training benefits, the American College of Sports Medicine recommends working out within a heart rate range of 55% to 90% of maximum heart rate. To predict the maximum heart rate, the following formula was used:  $220 - \text{Age} = \text{predicted maximum heart rate}$

## WARM-UP and COOL-DOWN

**Warm-Up** The purpose of warming up is to prepare your body for exercise and to minimize injuries. Warm up for two to five minutes before strength training or aerobic exercising. Perform activities that raise your heart rate and warm the working muscles. Activities may include brisk walking, jogging, jumping jacks, jump rope, and running in place.

**Stretching** Stretching while your muscles are warm after a proper warm-up and again after your strength or aerobic training session is very important. Muscles stretch more easily at these times because of their elevated temperature, which greatly reduces the risk of injury. Stretches should be held for 15 to 30 seconds. Do not bounce.

### Suggested Stretching Exercises

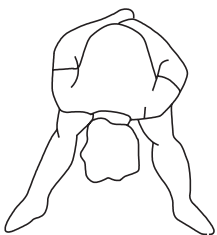

#### Lower Body Stretch

Place feet shoulder-width apart and lean forward. Keep this position for 30 seconds using the body as a natural weight to stretch the backs of the legs. **DO NOT BOUNCE!** When the pull on the back of the legs lessens, gradually try a lower position.

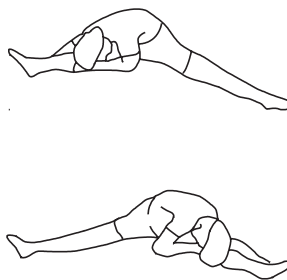

#### Floor Stretch

While sitting on the floor, open the legs as wide as possible. Stretch the upper body toward the knee on the right leg by using your arms to pull your chest to your thighs. Hold this stretch 10 to 30 seconds. **DO NOT BOUNCE!** Do this stretch 10 times. Repeat the stretch with the left leg.

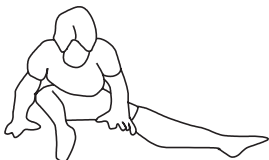

#### Bent Torso Pulls

While sitting on the floor, have legs apart, one leg straight and one knee bent. Pull the chest down to touch the thigh on the leg that is bent, and twist at the waist. Hold this position at least 10 seconds. Repeat 10 times on each side.

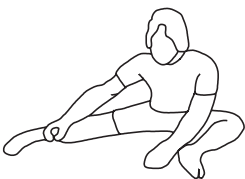

#### Bent Over Leg Stretch

Stand with feet shoulder-width apart and lean forward as illustrated. Using the arms, **gently** pull the upper body towards the right leg. Let the head hang down. **DO NOT BOUNCE!** Hold the position a minimum of 10 seconds. Repeat pulling the upper body to the left leg. Do this stretch several times slowly.

**Remember to always check with your physician before starting any exercise program.**

**Cool-Down** The purpose of cooling down is to return the body to its normal, or near normal, resting state at the end of each exercise session. A proper cool-down slowly lowers your heart rate and allows blood to return to the heart. Your cool-down should include the stretches listed above and should be completed after each strength training session.

# PRODUCT PARTS DRAWING

FRONT

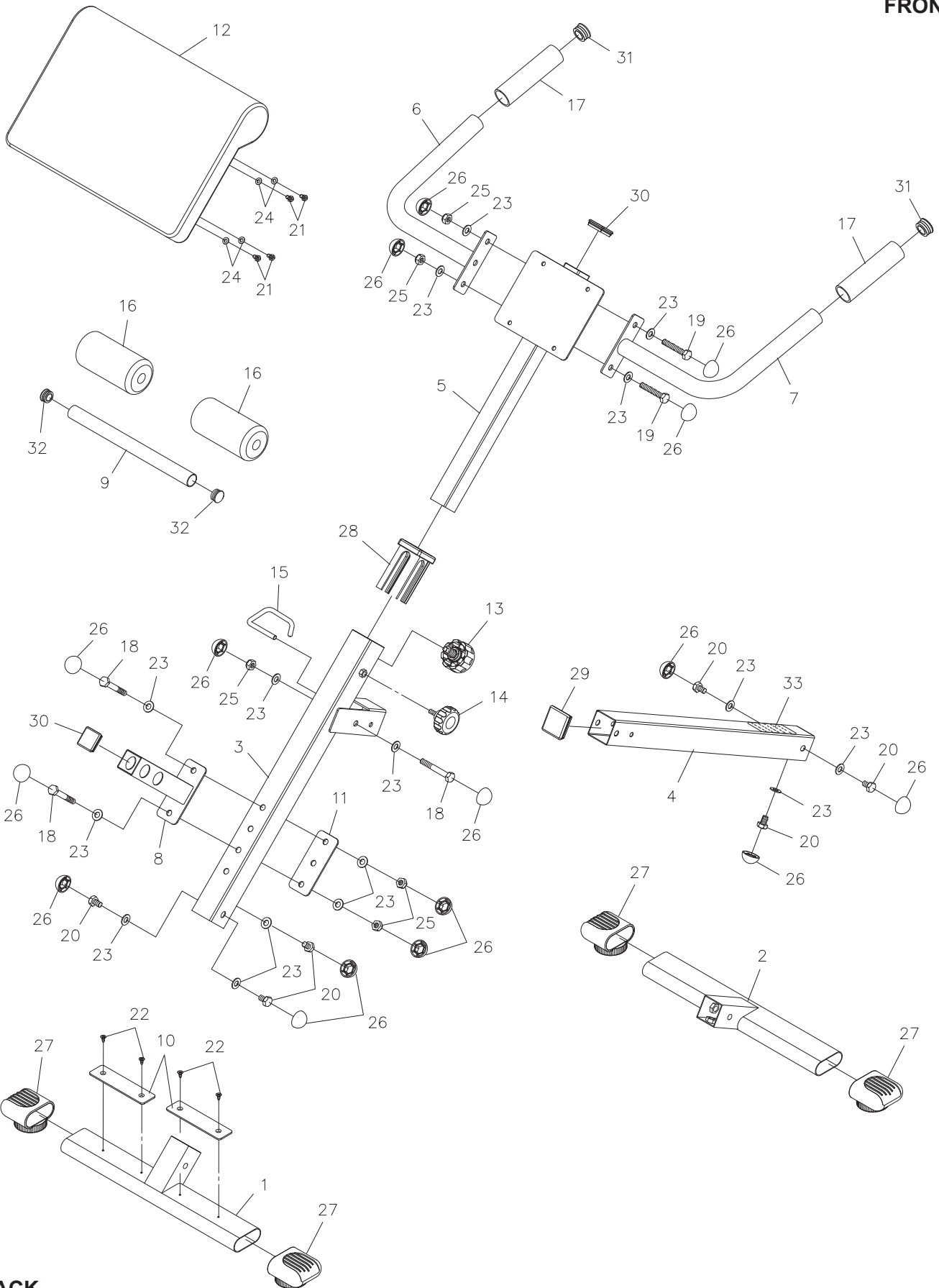

BACK

## PARTS LIST

PART#	PART NAME	QTY
1	Rear Stabilizer	1
2	Front Stabilizer	1
3	Main Support	1
4	Front Support	1
5	Cushion Post	1
6	Left Handrail	1
7	Right Handrail	1
8	Foam Roll Post	1
9	Support Tube	1
10	Foot Plate	2
11	Support Plate	1
12	Cushion	1
13	Adjustment Knob	1
14	Securing Knob	1
15	Locking Pin	1
16	Foam Roll	2
17	Foam Grip	2
18	Bolt, Hex Head (M10 x 1.5 x 70mm)	3
19	Bolt, Hex Head (M10 x 1.5 x 60mm)	2
20	Bolt, Hex Head (M10 x 1.5 x 20mm)	6
21	Bolt, Hex Head (M6 x 1 x 15mm)	4
22	Screw, Flat Head (M4 x 15mm)	4
23	Washer (M10)	16
24	Washer (M6)	4
25	Nylock Nut (M10 x 1.5)	5
26	Nut Cap (M10)	16
27	Oval Endcap (30mm x 70mm)	4
28	Bushing	1
29	Square Plug (50mm x 50mm)	1
30	Square Plug (38mm x 38mm)	2
31	Round Plug (ø31.8mm)	2
32	Round Plug (ø25.4mm)	2
33	Caution Label	1
34	Wrench	2
35	Manual	1

## **WARRANTY**

Stamina Products, Inc. warrants that this product will be free from defects in materials and workmanship under normal use, service and proper operation for a period of 90 days on the parts and one year on the frame from the date of the original purchase from an authorized retailer. **THIS WARRANTY SHALL NOT APPLY TO ANY PRODUCT WHICH HAS BEEN SUBJECT TO COMMERCIAL USE, ABUSE, MISUSE, ALTERATION OF ANY TYPE OR CAUSE OR TO ANY DEFECT OR DAMAGE CAUSED BY REPAIR, REPLACEMENT, SUBSTITUTION OR USE WITH PARTS OTHER THAN PARTS PROVIDED BY STAMINA PRODUCTS, INC.** Commercial use includes use of the product in athletic clubs, health clubs, spas, gymnasiums, exercise facilities, and other public or semipublic facilities whether or not the product's use is in furtherance of a profit making enterprise, and all other use which is not for personal, family, or household purposes.

To implement this limited warranty, send a written notice stating your name, date, and place of purchase and a brief description of the defect along with your receipt to **Stamina Products, Inc. P.O. Box 1071, Springfield Missouri, USA, 65801-1071**, or email us at **customerservice@staminaproducts.com**, or call us at **1-800-375-7520**. If the defect is covered under this limited warranty, you will be requested to return the product or part to us for free repair or replacement at our option. **NO ACTION FOR BREACH OF THIS LIMITED WARRANTY MAY BE COMMENCED MORE THAN ONE (1) YEAR AFTER THE DATE THE ALLEGED BREACH WAS OR SHOULD HAVE BEEN DISCOVERED. NO ACTION FOR BREACH OF ANY IMPLIED WARRANTY MAY BE COMMENCED MORE THAN ONE (1) YEAR AFTER DELIVERY OF THE PRODUCT TO THE PURCHASER.** This limited warranty is not transferable. **IF ANY PART OF THE PRODUCT IS NOT IN COMPLIANCE WITH THIS LIMITED WARRANTY OR ANY IMPLIED WARRANTY, THE REMEDY OF REPAIR OR REPLACEMENT IS THE EXCLUSIVE REMEDY AVAILABLE TO YOU.** In the event that the purchaser makes any claim under this limited warranty or any implied warranty, the Warrantor reserves the right to require the product to be returned for inspection, at the purchaser's expense, to the Warrantor's premises in Springfield, Missouri. Return of the enclosed warranty registration card is not required for warranty coverage, but is merely a way of establishing the date and place of purchase.

Stamina Products, Inc. **SHALL NOT BE LIABLE FOR THE LOSS OF USE OF ANY PRODUCT, LOSS OF TIME, INCONVENIENCE, COMMERCIAL LOSS OR ANY OTHER INDIRECT, CONSEQUENTIAL, SPECIAL OR INCIDENTAL DAMAGES DUE TO BREACH OF THE ABOVE WARRANTY OR ANY IMPLIED WARRANTY.**

This limited warranty is the only written or express warranty given by Stamina Products, Inc. This warranty gives you specific legal rights, and you may also have other legal rights which vary from state to state. **ANY OTHER RIGHT WHICH YOU MAY HAVE, INCLUDING ANY IMPLIED WARRANTY OR MERCHANTABILITY OR FITNESS FOR A PARTICULAR PURPOSE, IS LIMITED IN DURATION TO THE DURATION OF THIS WARRANTY.**

The laws in some jurisdictions restrict the rights of manufacturers and distributors of consumer goods to disclaim or limit implied warranties and consequential and incidental damages with respect thereto. If any such law is found to be applicable, the foregoing disclaimers and limitations of and on implied warranties and consequential and incidental damages with respect thereto shall be disregarded and shall be deemed not to have been made to the extent necessary to comply with such legal restriction.



## **NOTES**

## TO CONTACT CUSTOMER SERVICE

For your convenience, Stamina's customer service representatives can be reached by email at customerservice@staminaproducts.com or by phone at 1-800-375-7520 (in the U.S.). Our customer service representatives are available Monday through Thursday from 7:30 a.m. until 5:00 p.m., and Friday 8:00 a.m. until 3 p.m. Central Time.



**ONLINE  
CUSTOMER SERVICE**  
customerservice@staminaproducts.com  
www.staminaproducts.com



**TELEPHONE  
CUSTOMER SERVICE**  
Tel: 1 (800) 375-7520



**FAX  
CUSTOMER SERVICE**  
Fax: (417) 889-8064



**MAIL**  
**STAMINA PRODUCTS, INC.**  
ATTN: Customer Service  
P.O. Box 1071 Springfield, MO. 65801-1071

Would you like to receive email information or special offers from Stamina Products? Register at [contact.staminaproducts.com](http://contact.staminaproducts.com)

## TO REGISTER YOUR PRODUCT

To enact your warranty, please register your product by going to [register.staminaproducts.com](http://register.staminaproducts.com). Please have your product model number (printed on the cover of this owner's manual) and the serial number (printed on the black and white sticker on your product) ready.

If you don't have internet access, you can call customer service at 1-800-375-7520, or fill out and mail the product registration form below to Stamina Products, Inc.; P.O. Box 1071; Springfield, MO 65801-1071.

<b>PRODUCT REGISTRATION FORM</b>	<b>Stamina Products, Inc.</b> P.O. Box 1071 Springfield, MO 65801-1071
Model Number: .....	Serial Number: .....
Product Name: .....	
Place Purchased: .....	
Date of Purchase: .....	Purchase Price: .....
First Name: .....	Last Name: .....
City: .....	State: ..... Zip Code: .....
Email Address: .....	Phone #: (     ) .....
Would you like to receive email information or special offers from Stamina Products?* <input type="checkbox"/> Yes <input type="checkbox"/> No *If yes, be sure your email address is included above.	



Detach and Mail or Fax the Form Above



## TO ORDER PARTS

If there are missing or damaged parts, you can go to [parts.staminaproducts.com](http://parts.staminaproducts.com) and order those parts. If you have questions, please contact customer service. Do not return the product. To order parts by mail, fill out the sheet below and fax it to 417-889-8064. The part will be mailed to your address.



Detach and Mail or Fax the Form Below



<b>PARTS ORDER FORM</b>	<b>Stamina Products, Inc.</b> P.O. Box 1071 Springfield, MO 65801-1071	
Mr./Ms: .....		
Address: ..... Apt. #: .....		
City: ..... State: ..... Zip Code: .....		
<b>IMPORTANT : We must have your phone number to process the order!</b>		
Phone #: (     ) ..... Work Phone #: (     ) .....		
Date of Purchase: .....		
Model #: .....		
Purchased From: .....		
<b>IMPORTANT : Before filling out the form below make sure you have the correct information. Refer to the parts list to make sure you're ordering the right parts!</b>		
PART #	DESCRIPTION	QUANTITY
EXAMPLE: 1	Rear Unit Assembly	1

## Free Manuals Download Website

<http://myh66.com>

<http://usermanuals.us>

<http://www.somanuals.com>

<http://www.4manuals.cc>

<http://www.manual-lib.com>

<http://www.404manual.com>

<http://www.luxmanual.com>

<http://aubethermostatmanual.com>

Golf course search by state

<http://golfingnear.com>

Email search by domain

<http://emailbydomain.com>

Auto manuals search

<http://auto.somanuals.com>

TV manuals search

<http://tv.somanuals.com>