

Patent No. US 7,491,157 B1.  
Other patent(s) apply & are pending.

# 36 LB ADJUSTABLE KETTLE VERSA-BELL®

## Owner's Manual

Safety Instructions  
Customer Service  
Operation  
Warranty

### SAFETY INSTRUCTIONS

**⚠ WARNING:** To reduce the risk of serious injury, read the following Safety Instructions before using the **KETTLE VERSABELL®**.

1. Read this Owner's Manual and follow it carefully before using the **KETTLE VERSABELL®**.
2. Keep children away from the **KETTLE VERSABELL®**. Do not allow children to use or play around the **KETTLE VERSABELL®**. Keep children and pets away from the **KETTLE VERSABELL®** when it is in use.
3. Make sure that there is adequate space around your workout area when using the **KETTLE VERSABELL®**. Be careful not to strike any objects or the floor while using the **KETTLE VERSABELL®** as damage to the product or injury may occur.
4. Inspect the **KETTLE VERSABELL®** for damaged or loose components prior to use.
5. Tighten/replace any loose or worn components prior to using the **KETTLE VERSABELL®**.
6. Before exercising, check the Selector Pin(9) to verify that it is fully inserted into the adjustment hole to properly secure Weight Plates(10). Check the Bumper(5) to ensure it is properly covering the Selector Pin(9). Falling weights can result in severe injury.

**CAUTION:** Never adjust the Selector Pin(9) when the **KETTLE VERSABELL®** is removed from its **WEIGHT BASE(11)** and the **FLOOR PAD(28)**.

7. Consult a physician prior to commencing an exercise program. If at any time during exercise you feel faint, dizzy, or experience pain, stop and consult your physician.
8. Always choose the workout which best fits your physical strength and flexibility level. Know your limits and train within them. Always use common sense when exercising.
9. Do not wear loose or dangling clothing while using the **KETTLE VERSABELL®**.
10. The **KETTLE VERSABELL®** is for consumer use only. It is not for use in public or semipublic facilities.

This Product is Produced Exclusively by



2040 N. Alliance, Springfield, MO 65803  
Customer Service  
1 (800) 375-7520  
customerservice@staminaproducts.com  
www.staminaproducts.com

When calling for parts or  
service, please specify the  
following number:  
**05-3036**

MADE IN CHINA  
© 2010 Stamina Products, Inc.  
2010, 01

Part No. and Description	Qty
1. Top Cap	1
2. Handlebar	1
3. Upper Dome	1
4. Lower Dome	1
5. Bumper	1
6. Inner Ring	1
7. Outer Ring	1
8. Selector Rod	1
9. Selector Pin	1
10. Weight Plate	4
11. Weight Base	1
12. Weight Guide	2
13. Magnet	1
14. Screw, Flat Head (M2.5x0.45x20mm)	9
15. Bolt, Socket Head (M5 x 0.8 x 30mm)	8
16. Bolt, Socket Head (M6 x 1 x 18mm)	8
17. Nylock Nut (M2.5 x 0.45)	9
18. Nylock Nut (M12 x 1.75)	2
19. Nylock Nut (M16 x 2)	1
20. Lock Washer (M5)	8
21. Lock Washer (M6)	8
22. Lock Washer (M12)	2
23. Lock Washer (M16)	1
24. Washer (M2.5)	9
25. Washer (M6)	8
26. Washer (M12)	2
27. Washer (M16)	1
28. Floor Pad	1
29. Manual (not pictured)	1

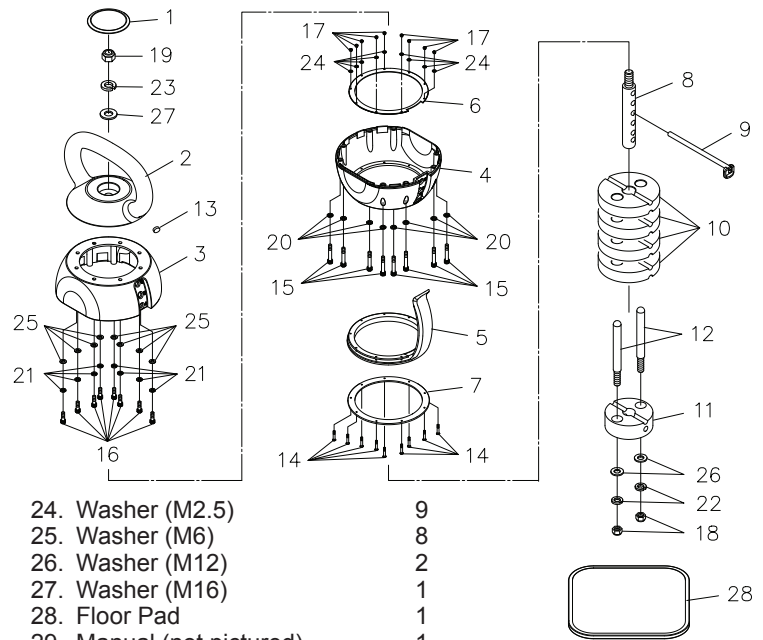

### OPERATIONAL INSTRUCTIONS

The **KETTLE VERSABELL®** has an internal selector rod device that allows the user to adjust the weights by using the **SELECTOR PIN(9)**. Follow the steps below to adjust and work out with your **KETTLE VERSABELL®** :

1. While on the **FLOOR PAD(28)**, pull the **BUMPER(5)** down. Change the workout weight by pulling out the **SELECTOR PIN(9)**, then re-inserting the **SELECTOR PIN(9)** into the desired adjustment hole. The weight number at the side of the selected hole shows the amount of weight selected for the workout. Push the **BUMPER(5)** back to the closed position.

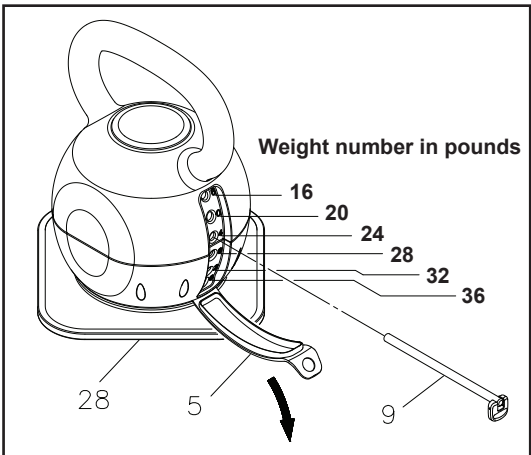

2. Lift the **KETTLE VERSABELL®** to begin the workout. The weight plates which are not selected will stay on the **FLOOR PAD(28)**. After the workout, always put the **KETTLE VERSABELL®** back on to the top of the unused weight plates on the **FLOOR PAD(28)**.

**CAUTION: Never adjust the SELECTOR PIN(9) when the KETTLE VERSABELL® is removed from the FLOOR PAD(28) and the WEIGHT PLATES(10) and WEIGHT BASE(11).**

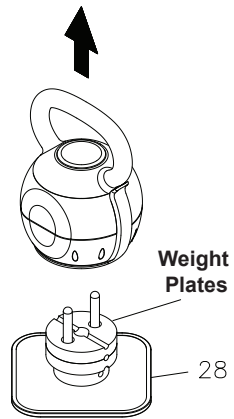

### LIMITED WARRANTY

This product is warranted to be free from defects in material and workmanship and to be in perfect working order at the time of purchase. This warranty applies to personal, family or household use. This warranty does not apply to use in athletic clubs, health clubs, spas, gymnasiums, exercise facilities, and other public or semipublic facilities.

If the product should, for any reason, become defective within 90 days of purchase, the manufacturer will replace the product once it is returned to the manufacturer. This warranty does not apply to any damage caused by accident, return transit, alteration, abuse, or misuse. There are no other warranties other than those expressly set forth herein.

Products shipped to the manufacturer must be in the original shipping carton with freight prepaid. All expenses for repairing or replacing the product, including the cost of shipping it back to the original purchaser, will be covered by the manufacturer. This warranty gives you specific legal rights, and you may have other rights which vary from state to state.

## Free Manuals Download Website

<http://myh66.com>

<http://usermanuals.us>

<http://www.somanuals.com>

<http://www.4manuals.cc>

<http://www.manual-lib.com>

<http://www.404manual.com>

<http://www.luxmanual.com>

<http://aubethermostatmanual.com>

Golf course search by state

<http://golfingnear.com>

Email search by domain

<http://emailbydomain.com>

Auto manuals search

<http://auto.somanuals.com>

TV manuals search

<http://tv.somanuals.com>