

STUDIO *Tower*[®] Combination Unit

Owner's Manual

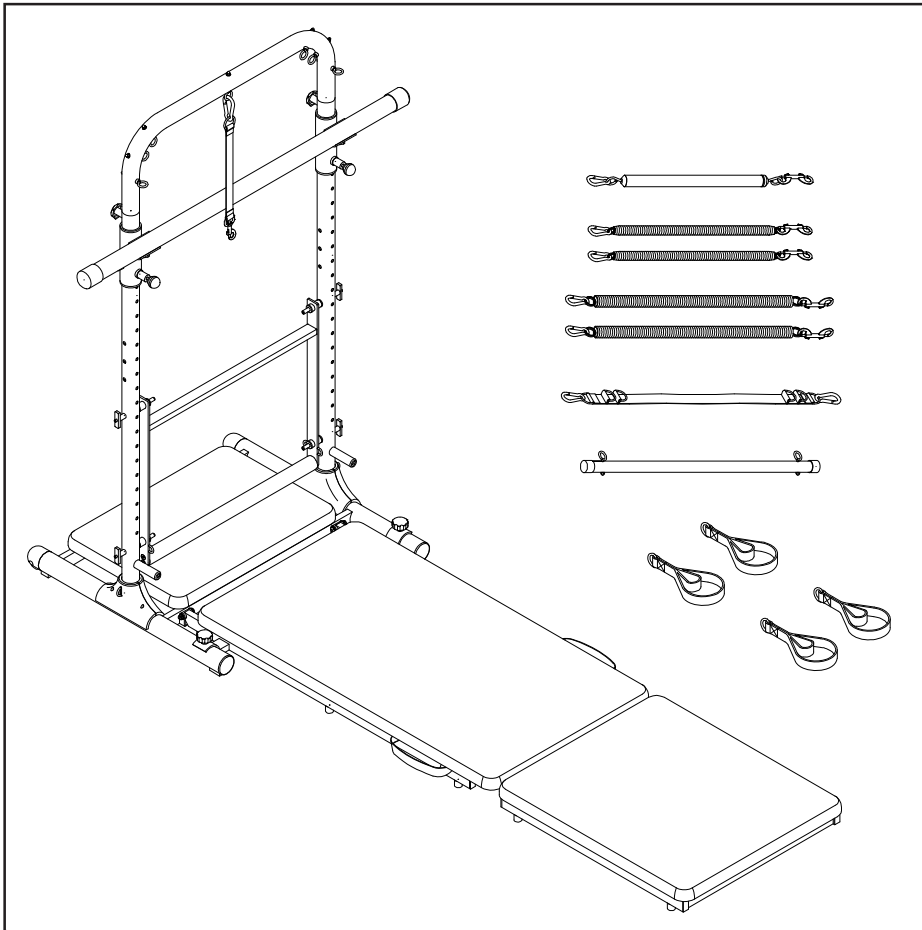

⚠ WARNING ⚠

Exercise can present a health risk. Consult a physician before beginning any exercise program with this equipment. If you feel faint or dizzy, immediately discontinue use of this equipment. Serious bodily injury can occur if this equipment is not assembled and used correctly. Serious bodily injury can also occur if all instructions are not followed. Keep others and pets away from equipment when in use. Always make sure all bolts and nuts are tightened prior to each use. Follow all safety instructions in this manual.

When calling for parts or service, please specify the following number.

20-1200

Patent(s) pending

MADE IN CHINA

Product May Vary Slightly
From Pictured.

CAUTION:
Weight on this product should not exceed 250 lbs.

This Product is Produced Exclusively by



2040 N. Alliance, Springfield, MO 65803

Customer Service Number

1 (800) 375-7520

www.staminaproducts.com

TABLE OF CONTENTS

	Page		Page
Safety Instructions	2	Operational Instructions	10
Before You Begin	4	Storage	14
Equipment Warning & Notice Labels	5	Warranty	15
Hardware Identification Chart	6	Product Parts Drawing	16
Assembly Instructions	7	Parts List	17
Maintenance	10	Fax/Mail Ordering Form	19

SAFETY INSTRUCTIONS

WARNING: To reduce the risk of serious injury, read the following Safety Instructions before using the Studio Tower®.

1. Read all warnings posted on the **Studio Tower®**.
2. Read this Owner's Manual before using the **Studio Tower®**.
3. We recommend that two people be available for assembly of this product.
4. Make sure that the **Studio Tower®** is properly assembled and tightened before use.
5. Set up and operate the **Studio Tower®** on a solid level surface. Do not position the **Studio Tower®** on loose rugs or uneven surfaces.
6. Make sure that adequate space is available for access to and around the **Studio Tower®**.
7. Inspect the Wooden Barre(13) for cracks before each use. Do not use the **Studio Tower®** if the Wooden Barre(13) is damaged.
8. Make sure that the Main Frame(1) is secured properly on the Base Frame(3) with the Locking Knobs(19) before using the **Studio Tower®**.
9. Always make sure that the Sliders(8,10) are adjusted to the same height with Spring Pins(12) in parallel holes in Uprights(7,9).
10. Inspect the **Studio Tower®** for worn or loose components prior to use.
11. Tighten/replace any loose or worn components prior to using the **Studio Tower®**.
12. Consult a physician prior to commencing an exercise program. If, at any time during exercise, you feel faint, dizzy, or experience pain, stop and consult your physician.
13. Follow your physician's recommendations in developing your own personal fitness program.
14. Always choose the workout which best fits your physical strength and flexibility level. Know your limits and train within them. Always use common sense when exercising.
15. Do not wear loose or dangling clothing while using the **Studio Tower®**.
16. Be careful to maintain your balance while using, mounting, dismounting, or assembling the **Studio Tower®**, loss of balance may result in a fall and serious bodily injury.
17. The **Studio Tower®** should not be used by persons weighing over 250 pounds.
18. The **Studio Tower®** should be used by only one person at a time.

WARNING: Before starting any exercise or conditioning program you should consult with your personal physician to see if you require a complete physical exam. This is especially important if you are over the age of 35, have never exercised before, are pregnant, or suffer from any illness. **READ AND FOLLOW THE SAFETY PRECAUTIONS. FAILURE TO FOLLOW THESE INSTRUCTIONS CAN RESULT IN SERIOUS BODILY INJURY.**

CALL US FIRST



Customer Service Number

1(800) 375-7520

**THANK YOU FOR PURCHASING THE
Studio Tower®**

To help you get started, we have pre-assembled most of your Studio Tower® at the factory with the exception of those few parts left unassembled for shipping purposes. Simply follow the few assembly instructions set forth in this manual. With regular workouts you will be getting your body into shape and on your way to achieving a happier and healthier lifestyle.

Should you have any questions,
please call our Customer Service Department toll-free number,
1 (800) 375-7520

Monday - Thursday, 7:30 A.M. - 5:00 P.M. Central Time.
Friday, 8:00 A.M. - 3:00 P.M. Central Time.



TELEPHONE
CUSTOMER SERVICE
Tel: 1 (800) 375-7520



FAX
CUSTOMER SERVICE
Fax: (417) 889-8064



ONLINE
CUSTOMER SERVICE
parts@staminaproducts.com
cust-srvc@staminaproducts.com
www.staminaproducts.com



MAIL
STAMINA PRODUCTS, INC.
ATTN: Customer Service
P.O. Box 1071
Springfield, MO. 65801-1071

BEFORE YOU BEGIN

Thank you for choosing the **Studio Tower®**. We take great pride in producing this quality product and hope it will provide many hours of quality exercise to make you feel better, look better and enjoy life to its fullest.

Yes, it's a proven fact that a regular exercise program can improve your physical and mental health. Too often, our busy lifestyles limit our time and opportunity to exercise. The **Studio Tower®** provides a convenient and simple method to begin your assault on getting your body in shape and achieving a happier and healthier lifestyle.

Before reading further, please review the drawing below and familiarize yourself with the parts that are labeled.

Read this manual carefully before using the **Studio Tower®**.

Although Stamina constructs its products with the finest materials and uses the highest standards of manufacturing and quality control, there can sometimes be missing parts or incorrectly sized parts. If you have any questions or problems with the parts included with your **Studio Tower®**, please do not return the product. Contact us **FIRST!**

If a part is missing or defective, please call us toll free at 1-800-375-7520 (in the U.S.). Our Customer Service Staff is available to assist you from 7:30 A.M. to 5:00 P.M. (Central Time) Monday through Thursday and 8:00 A.M. to 3:00 P.M. (Central Time) on Friday.

If you would like to contact us online, go to our website at www.staminaproducts.com and access the Customer Service section.

Be sure to have the name and model number of the product available when you contact us.

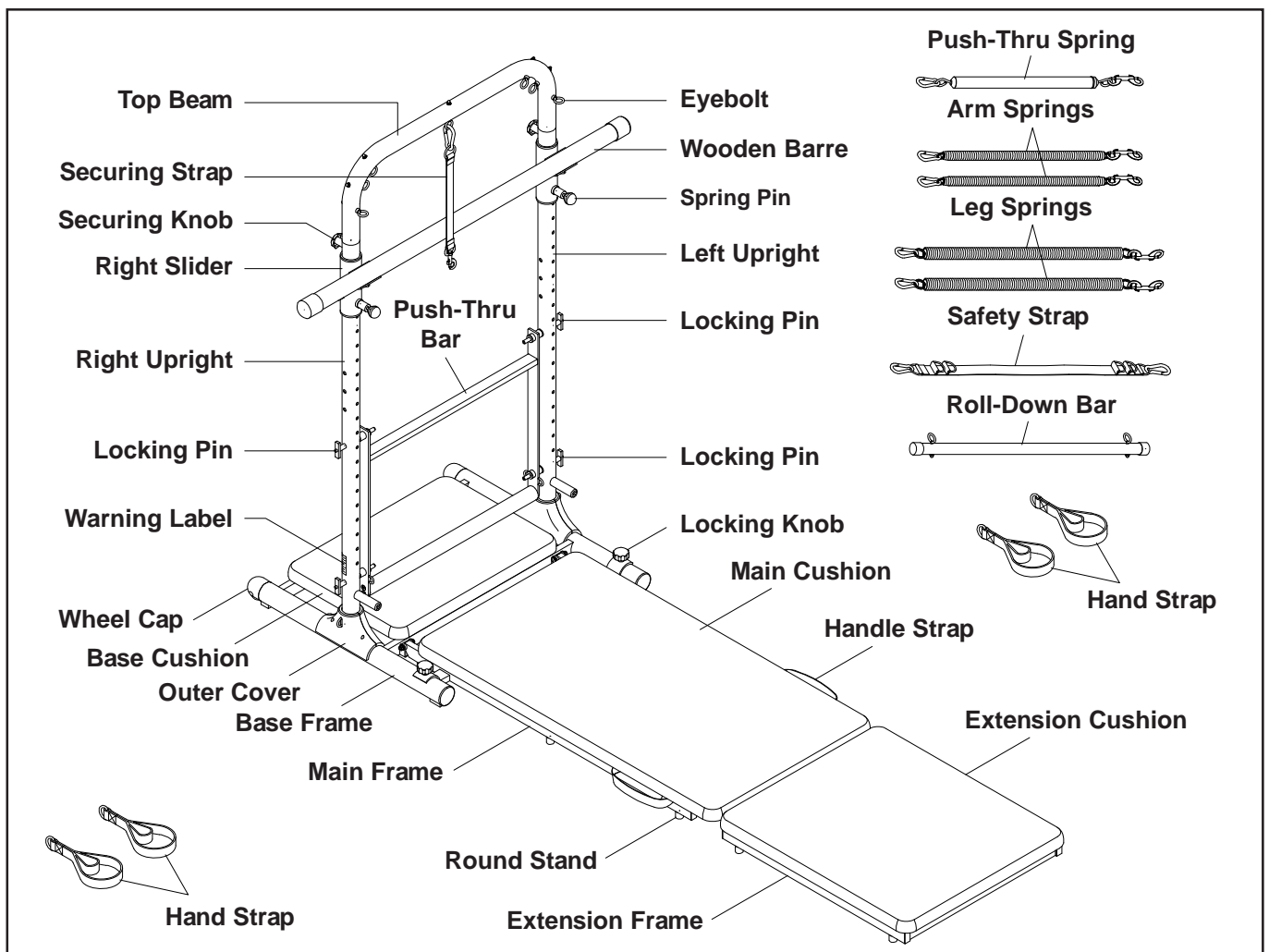

THE FOLLOWING TOOLS ARE REQUIRED FOR ASSEMBLY :



EQUIPMENT WARNING & NOTICE LABELS

This chart is provided to help identify the warning & notice labels on the **Studio Tower®**. Please take a moment to familiarize yourself with all of the warning & notice labels.

Label is larger than actual size

W1 WARNING LABEL(63)



HARDWARE IDENTIFICATION CHART



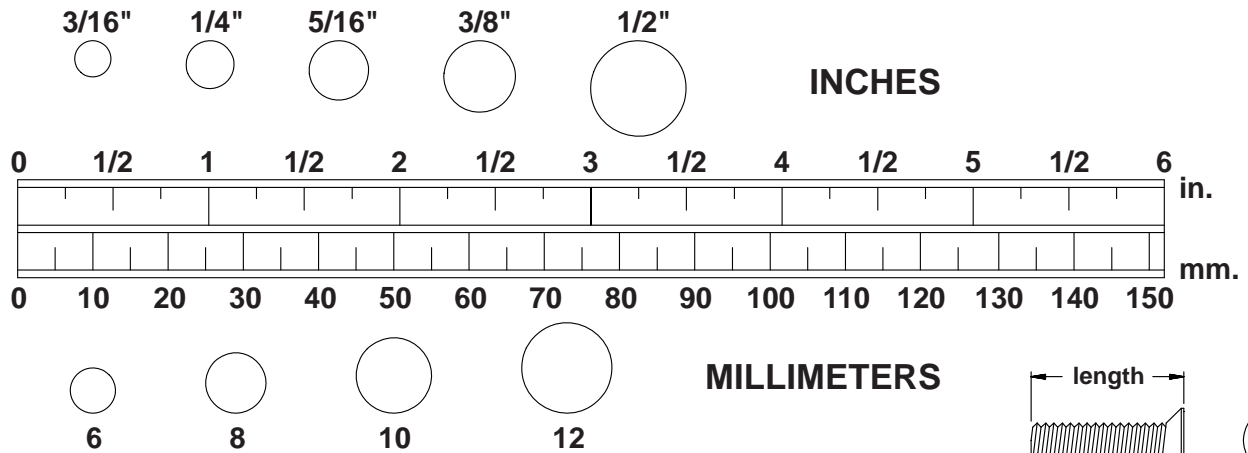

This chart is provided to help identify the hardware used in the assembly process. Place the washers, the ends of the bolts, or screws on the circles to check for the correct diameter. Use the small scale to check the length of the bolts and screws.

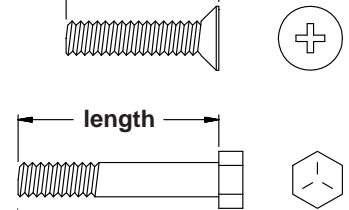

NOTICE: The length of all bolts and screws except those with flat heads is measured from below the head to the end of the bolt or screw. Flat head bolts and screws are measured from the top of the head to the end of the bolt or screw.

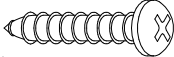
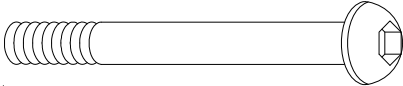
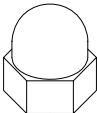

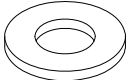
After unpacking the unit, open the hardware bag and make sure that you have all the following items. Some hardware may be already attached to the part.

	Part No. and Description	Qty
	45 Screw, Round Head (M4 x 20mm)	4
	47 Bolt, Button Head (M8 x 1.25 x 50mm)	2
	48 Bolt, Button Head (M8 x 1.25 x 55mm)	2
	49 Bolt, Button Head (M8 x 1.25 x 60mm)	4
	50 Bolt, Button Head (M8 x 1.25 x 70mm)	4
	55 Acorn Nut (M8 x 1.25)	4
	56 Nylock Nut (M8 x 1.25)	8
	59 Washer (M8)	12
	61 Arc Washer (M8)	4
	62 Lock Washer (M8)	4

ASSEMBLY INSTRUCTIONS

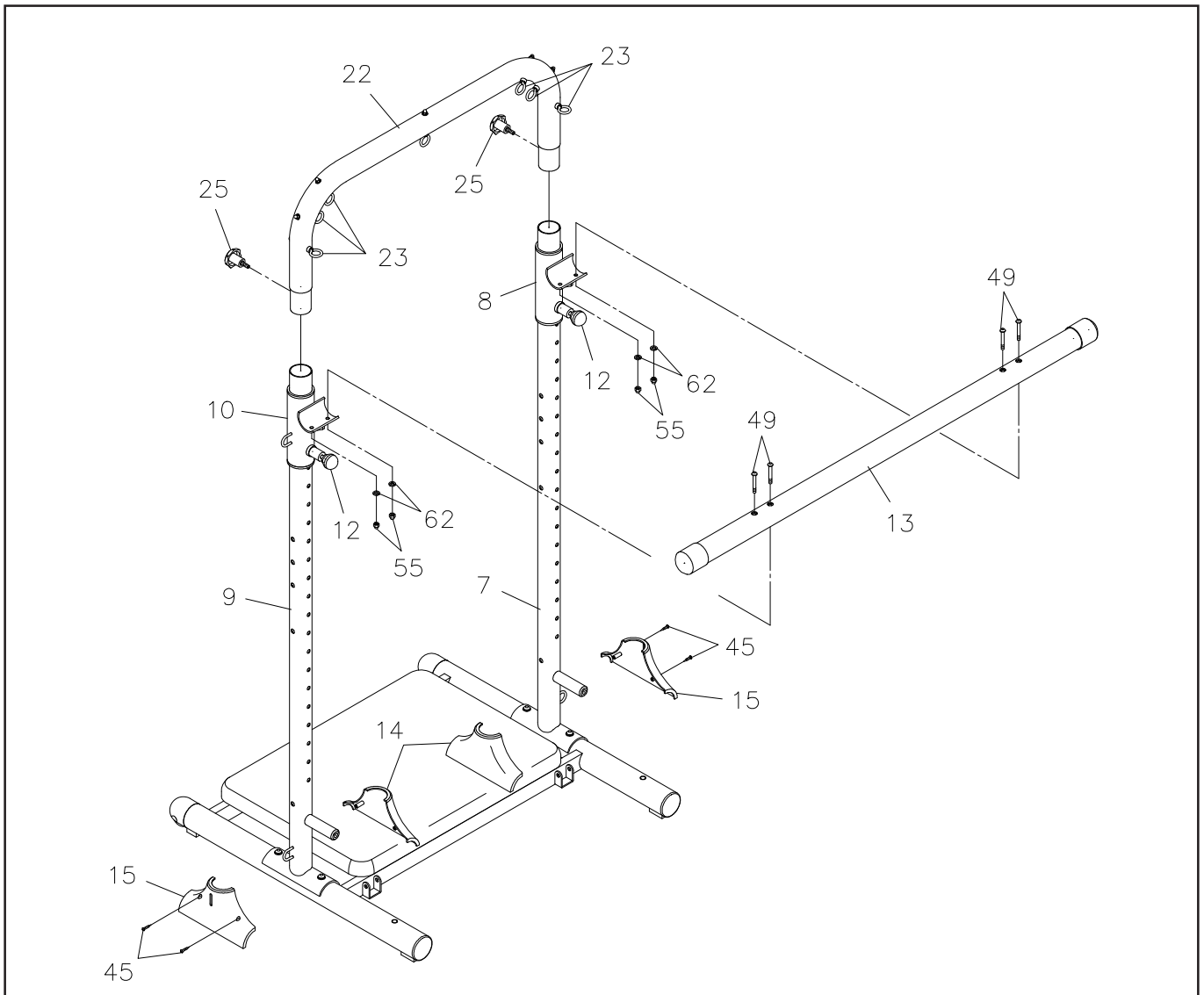

STEP 3

Attach the **WOODEN BARRE(13)** to the **LEFT** and **RIGHT SLIDERS(8, 10)** with **BUTTON HEAD BOLTS (M8x1.25x55mm)(49)**, **LOCK WASHERS(M8)(62)**, and **ACORN NUTS(M8x1.25)(55)**. Do not tighten the bolts until **STEP 5**.

STEP 4

Note the correct position of the holes and **EYEBOLTS(23)** on the **TOP BEAM(22)** in the illustration above. Insert the **TOP BEAM(22)** into the **LEFT** and **RIGHT UPRIGHTS(7, 9)** and secure with the **SECURING KNOBS(25)**.

STEP 5

Tighten the **BUTTON HEAD BOLTS(M8x1.25x60mm)(49)** to secure the **WOODEN BARRE(13)**. Tighten the **BUTTON HEAD BOLTS(M8x1.25x70mm)(50)** to secure the **LEFT** and **RIGHT UPRIGHT(7,9)**.

STEP 6

Attach the **OUTER COVER(15)** and **INNER COVER(14)** to the **RIGHT UPRIGHT(9)** with **ROUND HEAD SCREWS(M4x20mm)(45)**. Repeat on other side.

ASSEMBLY INSTRUCTIONS

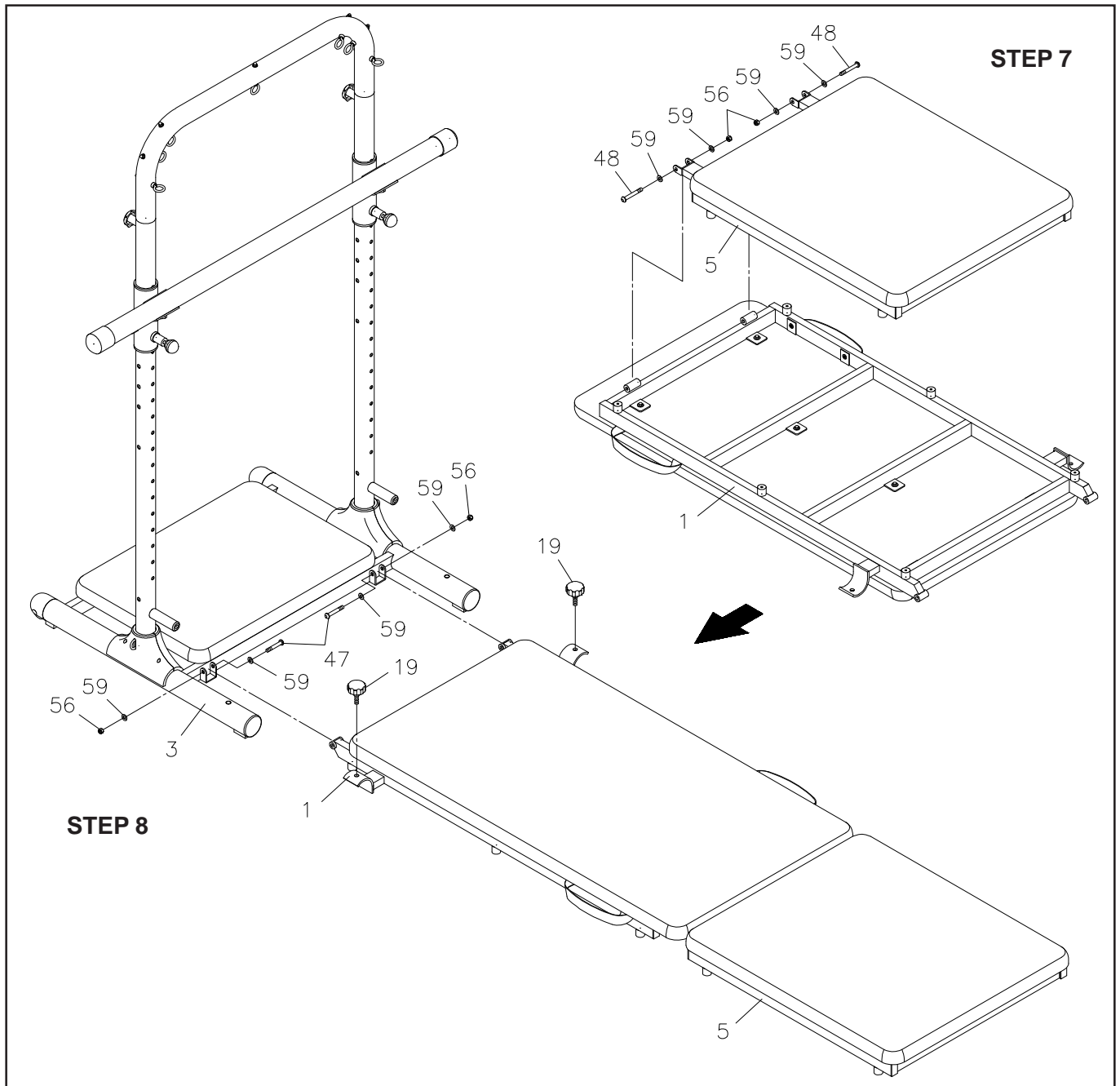

STEP 7

Refer to illustration step 7. Place the **MAIN FRAME(1)** with the cushion side face down. Attach the **EXTENSION FRAME(5)** to the **MAIN FRAME(1)** with **BUTTON HEAD BOLTS(M8x1.25x55mm)(48)**, **WASHERS(M8)(59)**, and **NYLOCK NUTS(M8x1.25)(56)**.

STEP 8

Refer to illustration step 8. Unfold the **EXTENSION FRAME(5)** from the **MAIN FRAME(1)** and turn the cushion side face up. Attach the **MAIN FRAME(1)** to the **BASE FRAME(3)** with **BUTTON HEAD BOLTS (M8x1.25x50mm)(47)**, **WASHERS(M8)(59)**, and **NYLOCK NUTS(M8x1.25)(56)**.

Lock the **MAIN FRAME(1)** and the **BASE FRAME(3)** together with the **LOCKING KNOBS(19)**.

MAINTENANCE

The safety and integrity designed into the **Studio Tower®** can only be maintained when the **Studio Tower®** is regularly examined for damage and wear. Special attention should be given to the following:

1. It is the sole responsibility of the user/owner to ensure that regular maintenance is performed.
2. Worn or damaged components should be replaced immediately or the **Studio Tower®** removed from service until repair is made.
3. Verify that the **WARNING LABEL(63)** is present and legible. Replace the **WARNING LABEL(63)** if it is missing or damaged.
4. Inspect the **WOODEN BARRE(13)** for cracks or other damage. Replace the **WOODEN BARRE(13)** if it is damaged.
5. Check the condition of the **SAFETY STRAP(37)**. Replace the strap if damaged or worn.
6. Check the condition of the **SPRINGS(34, 35, 36)**. Replace the springs that are damaged.
7. Check the **HAND STRAPS(21)** for damage. Replace damaged parts.
8. Check the **FOAM SLEEVE(29)**, and **SPRING SLEEVE(33)** and replace if damaged or worn.
9. Check the **CUSHIONS(2, 4, 6)** and replace if it is damaged or worn.
10. Only Stamina Products supplied components shall be used to maintain/repair the **Studio Tower®**.
11. Keep your **Studio Tower®** clean by wiping with an absorbent cloth after use.

OPERATIONAL INSTRUCTIONS

WOODEN BARRE ADJUSTMENT

To adjust the height of the **WOODEN BARRE(13)**. Turn the **SPRING PINS(12)** on the **LEFT** and **RIGHT SLIDERS (8, 10)** counter clockwise until the knob portion can be pulled. Pull both **SPRING PINS(12)** at the same time and slide the **SLIDERS(8, 10)** up or down to adjust. Release the **SPRING PINS(12)** to lock the **SLIDERS(8, 10)** in the desired adjustment holes. Rotate the **SPRING PINS(12)** clockwise to lock the **SLIDERS(8, 10)** securely.

NOTE:

Always make sure that the **SLIDERS(8,10)** are adjusted so the barre is parallel with the mat.

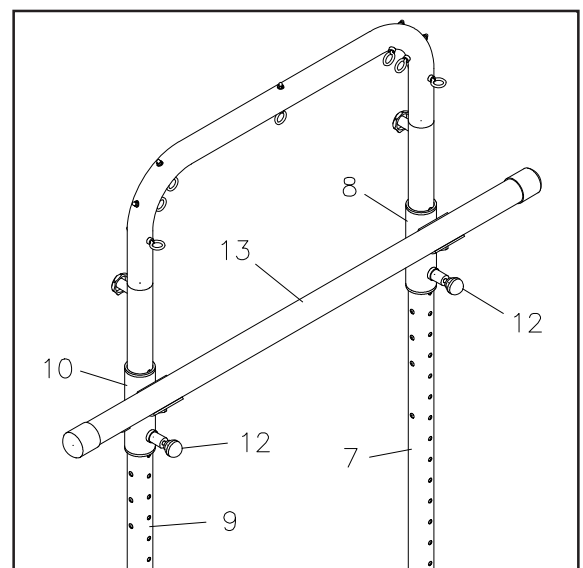

OPERATIONAL INSTRUCTIONS

SET-UP FOR THE PUSH-THRU BAR

- NOTE:**
- There are three adjustment holes in the **LEFT** and **RIGHT UPRIGHTS(7, 9)** that allow you to attach the **PUSH-THRU BAR(26)** at one of three different heights.
 - Refer to the inset drawing. Push down the button on the "T" end of the **LOCKING PIN(30)** to release the steel ball on the other end of the pin. Then you can insert the **LOCKING PIN(30)** into the adjustment hole. Push the button to remove the pin.
 - Always make sure **SAFETY STRAP(37)** is connected when the **PUSH-THRU BAR(26)** is in use.
 - Always use **SECURING STRAP(32)** to keep the **PUSH-THRU BAR(26)** in a secure position when not in use.

- Attach the **PUSH-THRU BAR(26)** to one of the adjustment holes in the **UPRIGHTS(7, 9)** with two **LOCKING PINS(30)**.
- Attach the **SECURING STRAP(32)** to the **EYEBOLT(23)** on the top of the **TOP BEAM(22)**. For some exercises, the **PUSH-THRU BAR(26)** should be up and secured in position with the **SECURING STRAP(32)**.
- The **PUSH-THRU BAR(26)** can be used as a footbar for some exercises. Attach the **PUSH-THRU BAR(26)** to the lowest adjustment holes in the **UPRIGHTS(7, 9)** with two **LOCKING PINS(30)**. Lock the **PUSH-THRU BAR(26)** and **UPRIGHTS(7, 9)** together with two **LOCKING PINS(30)**.

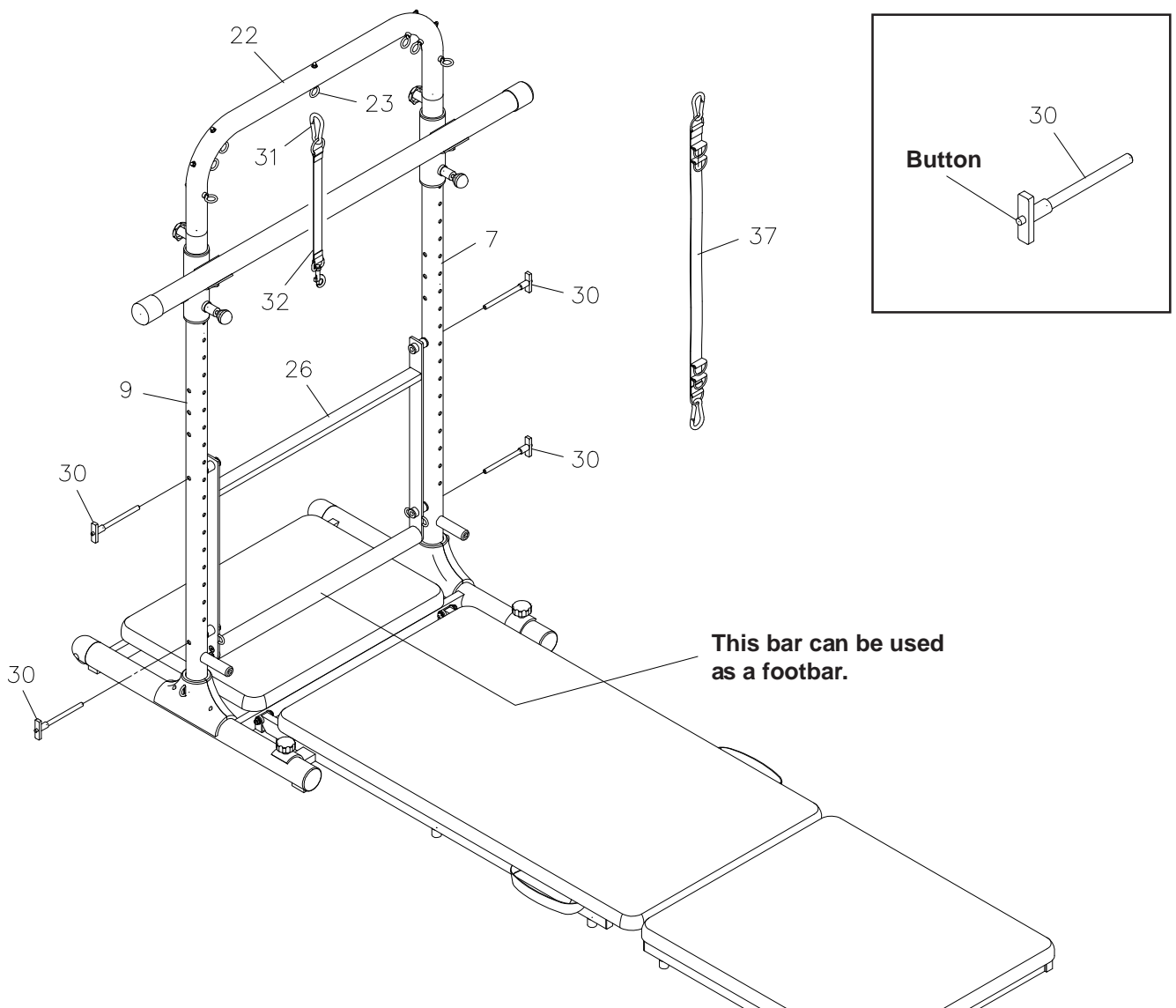

OPERATIONAL INSTRUCTIONS

TO USE THE ACCESSORIES:

PUSH-THRU BAR(26)

When doing exercises that require the spring resistance to come from above the bar, attach the **PUSH-THRU SPRING(34)** to the loop on the upper side of the **PUSH-THRU BAR(26)** with the **DOUBLE ENDED CLIP(38)**. Attach the other end of the **PUSH-THRU SPRING(34)** to one of the loops on the **TOP BEAM(22)** with the **LINK(31)**. Refer to illustration A.

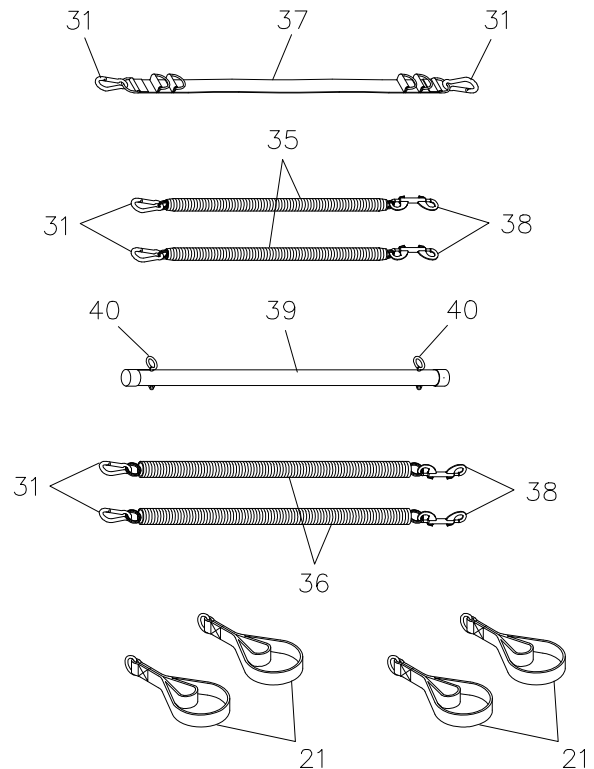
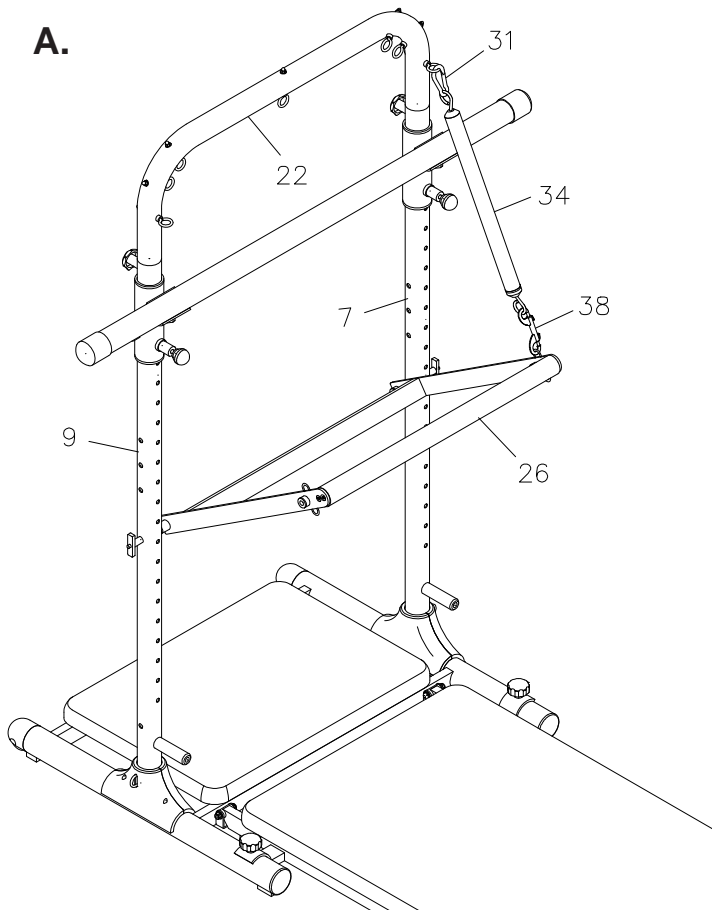

When doing exercises that require the spring resistance to come from below the bar, attach the **PUSH-THRU SPRING(34)** to the loop on the underside of the **PUSH-THRU BAR(26)** with the **DOUBLE ENDED CLIP(38)**. Attach the other end of the **PUSH-THRU SPRING(34)** to one of the loops on the **UPRIGHTS(7, 9)** with the **LINK(31)**. Be sure that the **SAFETY STRAP(37)** is always connected to the **PUSH-THRU BAR(26)** when in use. Refer to illustration B.

CAUTION !

When using the **PUSH-THRU SPRING(34)** from below, you must hook the spring to the loops on the **UPRIGHTS(7, 9)** with the **LINK(31)** and make sure the **SAFETY STRAP(37)** is connected. Ensure that the **SPRING SLEEVE(33)** which covers the **PUSH-THRU SPRING(34)** is moved over the lower part of the spring to avoid pulling the user's hair or clothing.

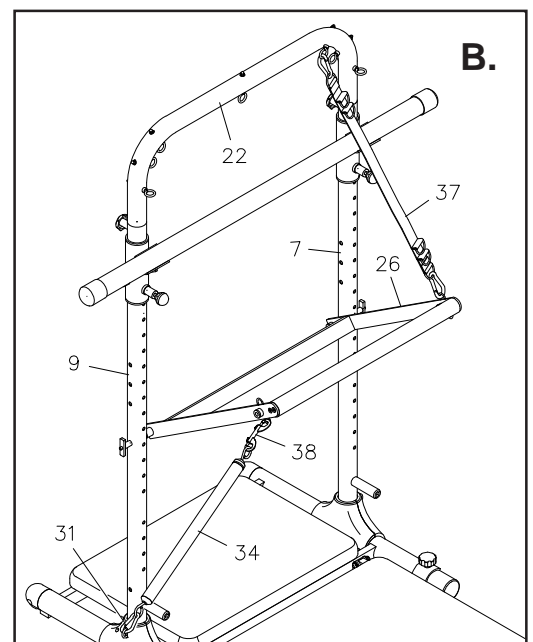

OPERATIONAL INSTRUCTIONS

TO USE THE ACCESSORIES: (continued)

SAFETY STRAP(37)

Refer to the illustration. The **SAFETY STRAP(37)** must be used as follows:

When using the **PUSH-THRU BAR(26)** with the **PUSH-THRU SPRING(34)** attached from below for bottom load exercises, attach the **SAFETY STRAP(37)** to another side of the tower from the spring. Connect one end of the strap to one of the **EYEBOLTS(23)** on the **TOP BEAM(22)** with the **LINK(31)**. Connect the other end of the strap to the loop on the **PUSH-THRU BAR(26)** with the **LINK(31)**.

NOTE:

There are three D rings on each end of the **SAFETY STRAP(37)**. Connect the **SAFETY STRAP(37)** with different D rings to set the **PUSH-THRU BAR(26)** in different position.

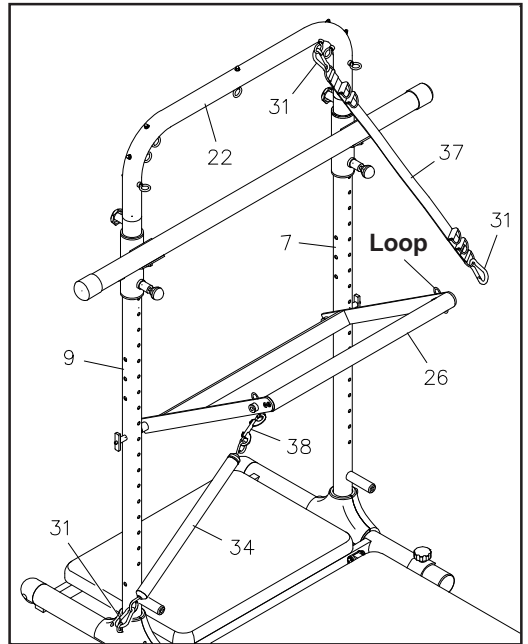

ROLL-DOWN BAR(39)

The **ROLL-DOWN BAR(39)** attaches via the **ARM SPRINGS(35)** to the **EYEBOLTS(23)** on the **TOP BEAM(22)** between the two **UPRIGHTS(7,9)** with the **LINKS(31)**. Attach the **ARM SPRINGS(35)** to the **ROLL-DOWN BAR(39)** with the **DOUBLE ENDED CLIPS(38)**. Be sure the links and clips are completely closed and secure.

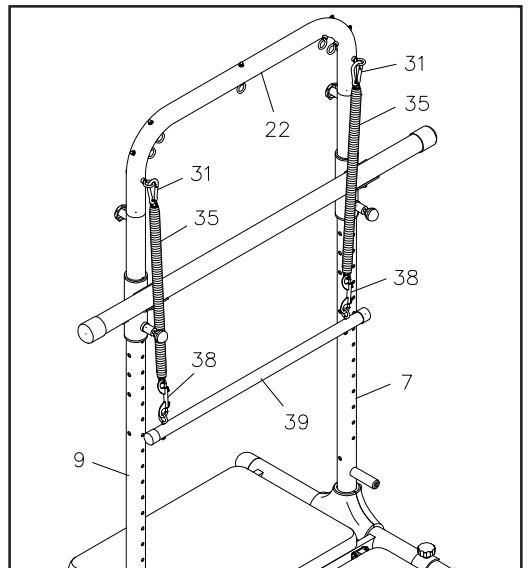

ARM SPRINGS(35)

Attach **ARM SPRINGS(35)** to eyebolts at desired height with the **LINKS(31)**. Attach the other ends of the springs to the **HAND STRAPS(21)** with the **DOUBLE ENDED CLIPS(38)**. Ensure the links and clips are completely closed and secured.

LEG SPRINGS(36)

Attach **LEG SPRINGS(36)** to eyebolts at desired height with the **LINKS(31)**. Attach the other ends of the springs to the **HAND STRAPS(21)** with the **DOUBLE ENDED CLIPS(38)**. Ensure the links and clips are completely closed and secured.

STORAGE

1. Store the **Studio Tower®** in a clean, dry place.

WARNING: When folding or unfolding the **Studio Tower®**, keep all children away from the **Studio Tower®** and make sure your hands are clear of any folding or pinch point.

2. Follow these steps and refer to the illustration to fold the **Studio Tower®** for easy storage.
 - a. Move any attached accessories to the back side of the tower so the mats can fold up against the **WOODEN BARRE(13)**.
 - b. Remove the **LOCKING KNOBS(19)** to unlock the **MAIN FRAME(1)**.
 - c. With one hand on one of the **HANDLE STRAPS(20)** on the **MAIN CUSHION(2)**, and one hand on the **EXTENSION FRAME(5)**, slowly lift the **MAIN FRAME(1)** and **EXTENSION FRAME(5)**. The **EXTENSION FRAME(5)** will fold down against the **MAIN FRAME(1)** as you lift.
 - d. When both frames are in the most vertical position possible, parallel to the **LEFT** and **RIGHT UPRIGHTS(7,9)**, secure the **MAIN FRAME(1)** to the **LEFT** and **RIGHT UPRIGHTS(7,9)** with the **LOCKING KNOBS(19)**.
3. To move the **Studio Tower®**, it must be folded. While standing on the **BASE CUSHION(4)** side of the folded **Studio Tower®**, grasp the **TOP BEAM(22)** with one hand, place your foot against the **BASE CUSHION(4)**, and hold the **LEFT** or **RIGHT UPRIGHT(7,9)** with your other hand. Pull the top of the **Studio Tower®** toward you while holding the base steady with your foot until the wheels come in contact with the floor. Then roll the **Studio Tower®** while holding the **TOP BEAM(22)** and **LEFT** or **RIGHT UPRIGHT(7,9)** to steady and guide the **Studio Tower®**

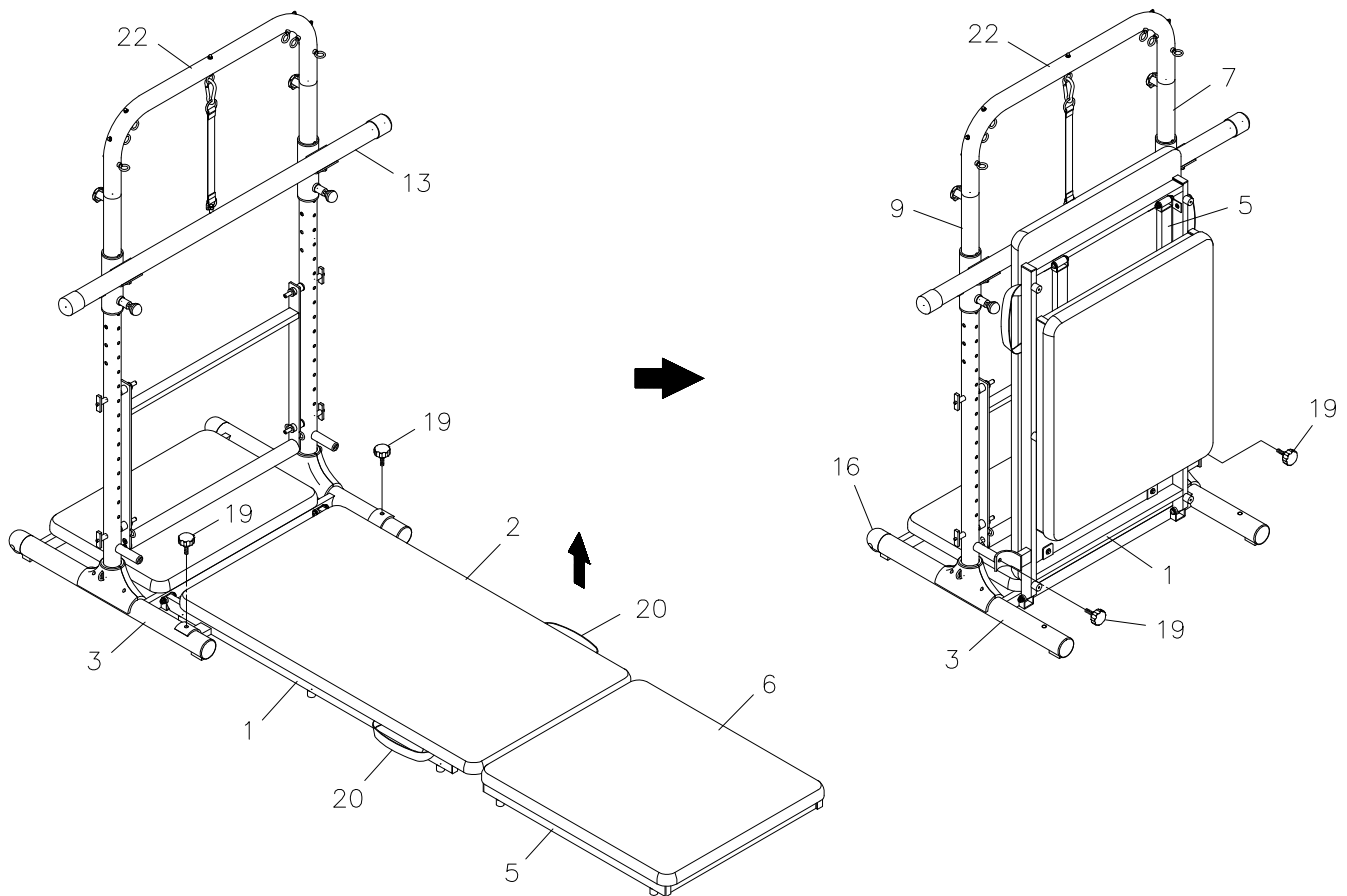

UNFOLD THE Studio Tower®

- a. Remove the **LOCKING KNOBS(19)** from the **UPRIGHTS(7, 9)**.
- b. With one hand on one of the **HANDLE STRAPS(20)** on the **MAIN CUSHION(2)**, and one hand on the **EXTENSION FRAME(5)**, slowly unfold and lower the **MAIN FRAME(1)** and **EXTENSION FRAME(5)**.
- c. Lock the **MAIN FRAME(1)** to the **BASE FRAME(3)** with the **LOCKING KNOBS(19)**.

WARRANTY

Stamina Products, Inc. warrants that this product will be free from defects in materials and workmanship under normal use, service and proper operation for a period of 90 days on parts and upholstery and 5 years on the frame from the date of the original purchase from an authorized retailer. **THIS WARRANTY SHALL NOT APPLY TO ANY PRODUCT WHICH HAS BEEN SUBJECT TO ABUSE, MISUSE, ALTERATION OF ANY TYPE OR CAUSE OR TO ANY DEFECT OR DAMAGE CAUSED BY REPAIR, REPLACEMENT, SUBSTITUTION OR USE WITH PARTS OTHER THAN PARTS PROVIDED BY STAMINA PRODUCTS, INC.**

To implement this limited warranty, send a written notice stating your name, date, and place of purchase and a brief description of the defect along with your receipt to **Stamina Products, Inc. P.O. Box 1071, Springfield Missouri, USA, 65801-1071** or call us at **1 (800) 375-7520**. If the defect is covered under this limited warranty, you will be requested to return the product or part to us for free repair or replacement at our option. **NO ACTION FOR BREACH OF THIS LIMITED WARRANTY MAY BE COMMENCED MORE THAN ONE (1) YEAR AFTER THE DATE THE ALLEGED BREACH WAS OR SHOULD HAVE BEEN DISCOVERED. NO ACTION FOR BREACH OF ANY IMPLIED WARRANTY MAY BE COMMENCED MORE THAN ONE (1) YEAR AFTER DELIVERY OF THE PRODUCT TO THE PURCHASER.** This limited warranty is not transferable. **IF ANY PART OF THE PRODUCT IS NOT IN COMPLIANCE WITH THIS LIMITED WARRANTY OR ANY IMPLIED WARRANTY, THE REMEDY OF REPAIR OR REPLACEMENT IS THE EXCLUSIVE REMEDY AVAILABLE TO YOU.** In the event that the purchaser makes any claim under this limited warranty or any implied warranty, the Warrantor reserves the right to require the product to be returned for inspection, at the purchaser's expense, to the Warrantor's premises in Springfield, Missouri. Return of the enclosed warranty registration card is not required for warranty coverage, but is merely a way of establishing the date and place of purchase.

Stamina Products, Inc. **SHALL NOT BE LIABLE FOR THE LOSS OF USE OF ANY PRODUCT, LOSS OF TIME, INCONVENIENCE, OR ANY OTHER INDIRECT, CONSEQUENTIAL, SPECIAL OR INCIDENTAL DAMAGES DUE TO BREACH OF THE ABOVE WARRANTY OR ANY IMPLIED WARRANTY.**

This limited warranty is the only written or express warranty given by Stamina Products, Inc. This warranty gives you specific legal rights, and you may also have other legal rights which vary from state to state. **ANY OTHER RIGHT WHICH YOU MAY HAVE, INCLUDING ANY IMPLIED WARRANTY OR MERCHANTABILITY OR FITNESS FOR A PARTICULAR PURPOSE, IS LIMITED IN DURATION TO THE DURATION OF THIS WARRANTY.**

The laws in some jurisdictions restrict the rights of manufacturers and distributors of consumer goods to disclaim or limit implied warranties and consequential and incidental damages with respect thereto. If any such law is found to be applicable, the foregoing disclaimers and limitations of and on implied warranties and consequential and incidental damages with respect thereto shall be disregarded and shall be deemed not to have been made to the extent necessary to comply with such legal restriction.

PRODUCT PARTS DRAWING

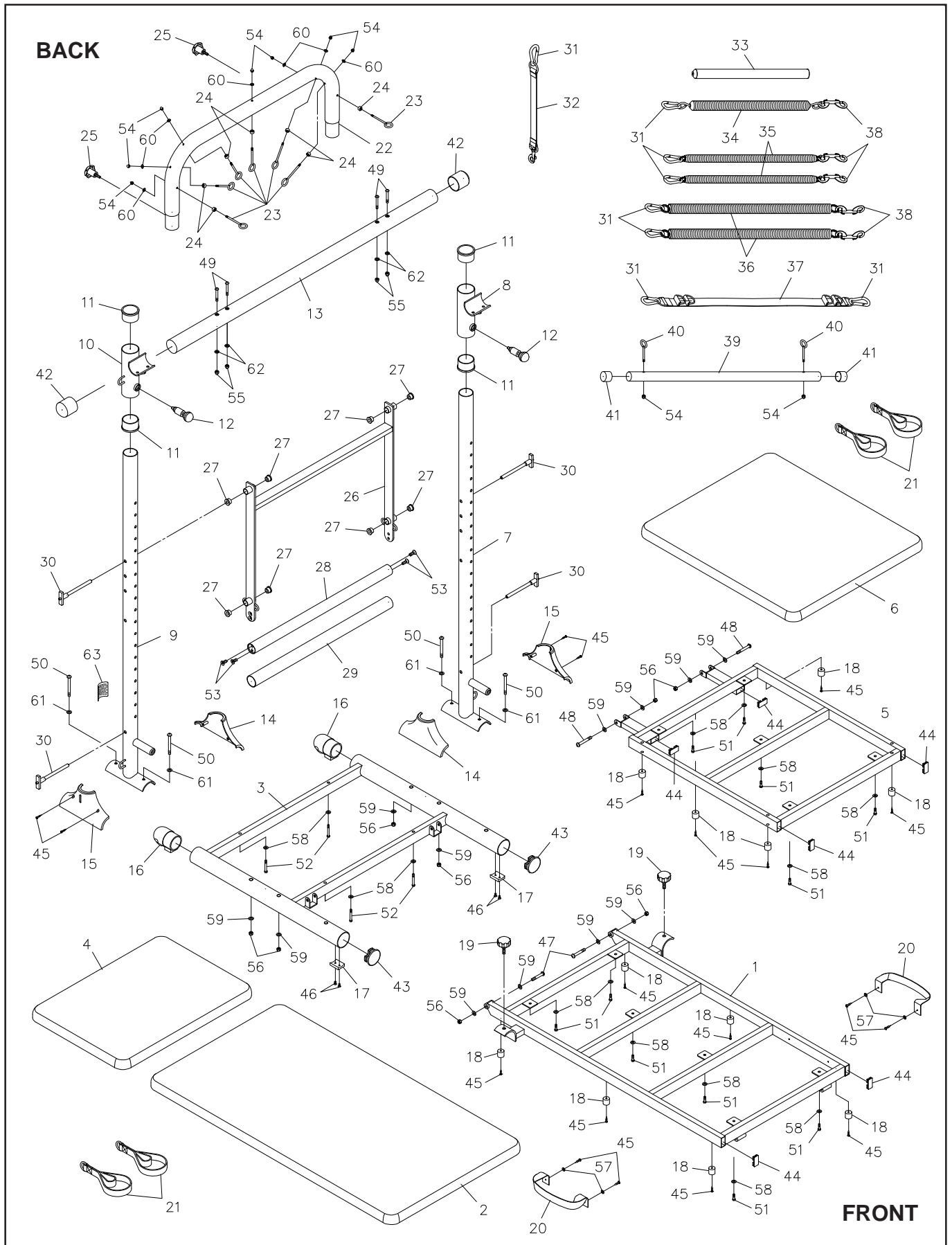

PARTS LIST

DIAGRAM#	PART NAME	QTY
1	Main Frame	1
2	Main Cushion	1
3	Base Frame	1
4	Base Cushion	1
5	Extension Frame	1
6	Extension Cushion	1
7	Left Upright	1
8	Left Slider	1
9	Right Upright	1
10	Right Slider	1
11	Slider Bushing	4
12	Spring Pin	2
13	Wooden Barre	1
14	Inner Cover	2
15	Outer Cover	2
16	Wheel Cap	2
17	Base Stand	2
18	Round Stand	11
19	Locking Knob	2
20	Handle Strap	2
21	Hand Strap	4
22	Top Beam	1
23	Eyebolt	7
24	Plastic Spacer	7
25	Securing Knob	2
26	Push-Thru Bar	1
27	Push-Thru Bar Bushing	8
28	Crossing Bar	1
29	Foam Sleeve	1
30	Locking Pin	4
31	Link	8
32	Securing Strap	1
33	Spring Sleeve	1
34	Push-Thru Spring	1
35	Arm Spring	2
36	Leg Spring	2
37	Safety Strap	1
38	Double Ended Clip	5
39	Roll-down Bar	1
40	Short Eyehook	2
41	Endcap (31.8mm)	2
42	Endcap (50mm)	2
43	Round Plug (60mm)	2
44	Rectangular Plug (20mm x 40mm)	6
45	Screw, Round Head (M4 x 20mm)	19
46	Screw, Flat Head (M5 x 0.8 x 8mm)	4
47	Bolt, Button Head (M8 x 1.25 x 50mm)	2

PARTS LIST

DIAGRAM#	PART NAME	QTY
48	Bolt, Button Head (M8 x 1.25 x 55mm)	2
49	Bolt, Button Head (M8 x 1.25 x 60mm)	4
50	Bolt, Button Head (M8 x 1.25 x 70mm)	4
51	Bolt, Hex Head (M6 x 1 x 20mm)	11
52	Bolt, Hex Head (M6 x 1 x 55mm)	4
53	Bolt, Flat Head (M6 x 1 x 15mm)	4
54	Acorn Nut (M6 x 1)	9
55	Acorn Nut (M8 x 1.25)	4
56	Nylock Nut (M8 x 1.25)	8
57	Washer (M4)	4
58	Washer (M6)	15
59	Washer (M8)	12
60	Arc Washer (M6)	7
61	Arc Washer (M8)	4
62	Lock Washer (M8)	4
63	Warning Label	1
64	Allen Wrench (6mm)	1
65	Combination Wrench	1
66	Manual	1
67	Video Disc (DVD)	1

Free Manuals Download Website

<http://myh66.com>

<http://usermanuals.us>

<http://www.somanuals.com>

<http://www.4manuals.cc>

<http://www.manual-lib.com>

<http://www.404manual.com>

<http://www.luxmanual.com>

<http://aubethermostatmanual.com>

Golf course search by state

<http://golfingnear.com>

Email search by domain

<http://emailbydomain.com>

Auto manuals search

<http://auto.somanuals.com>

TV manuals search

<http://tv.somanuals.com>