

POWER SUPPLY



Reliable 250 Watt Replacement ATX
Power Supply

ATXPOWER250
ATXPOWR250GB

Instruction Guide



* ATXPOWER250 shown

* Actual product may vary from photo

FCC COMPLIANCE STATEMENT

This equipment has been tested and found to comply with the limits for a Class B digital device, pursuant to part 15 of the FCC Rules. These limits are designed to provide reasonable protection against harmful interference in a residential installation. This equipment generates, uses and can radiate radio frequency energy and, if not installed and used in accordance with the instructions, may cause harmful interference to radio communications. However, there is no guarantee that interference will not occur in a particular installation.

Technical Support

The following technical resources are available for this StarTech.com product:

On-line help:

We are constantly adding new information to the *Tech Support* section of our web site. To access this page, click the *Tech Support* link on our homepage, www.startech.com. In the tech support section there are a number of options that can provide assistance with this product.

Knowledge Base - This tool allows you to search for answers to common issues using key words that describe the product and your issue.

FAQ - This tool provides quick answers to the top questions asked by our customers.

Downloads - This selection takes you to our driver download page where you can find the latest drivers for this product.

Call StarTech.com tech support for help:

USA/Canada: 1-519-455-4931

UK/Ireland/Europe: 00-800-7827-8324

Support hours: Monday to Friday 9:00AM to 5:00PM EST (except holidays)

Warranty Information

This product is backed by a two-year warranty. In addition StarTech.com warrants its products against defects in materials and workmanship for the periods noted, following the initial date of purchase. During this period, the products may be returned for repair, or replacement with equivalent products at our discretion. The warranty covers parts and labor costs only. StarTech.com does not warrant its products from defects or damages arising from misuse, abuse, alteration, or normal wear and tear.

Limitation of Liability

In no event shall the liability to StarTech.com Ltd. (or its officers, directors, employees or agents) for any damages (whether direct or indirect, special, punitive incidental, consequential, or otherwise), loss of profits, loss of business, or any pecuniary loss, arising out of related to the use of the product exceed the actual price paid for the product.

Some states do not allow the exclusion or limitation of incidental or consequential damages. If such laws apply, the limitations or exclusions contained in this statement may not apply to you.

Product Specifications

Dimensions	5.9 x 3.35 x 5.87 inches (150 x 85 x 149mm)
Weight	ATXPOWER250: 2.88 lbs (1.3 kg) ATXPOWR250GB: 3.69 lbs (1.65 kg)
Input Voltage	115/230V
Output Power	250W
Connectors	4 x 4-pin-LP4-female 1 x small-internal-power 1 x 20-pin-ATX-motherboard-adapter 1 x 4-pin extended ATX power 12V plug and Aux plug for Pentium 4
MTBF	100,000 Hours @ 25 Deg. C.
Safety Approvals	TUV, UL, CSA, CE, FCC, CB
AC INPUT	Voltage 115V~ Current 7A Voltage 230V~ Current 4A Frequency 50~60Hz
DC OUTPUT	+3.3V(20A) +5V(25A) +12V(13A) -5V(0.5A) -12V(0.8A) +5VSB(2.0A)

Table of Contents

Introduction	2
Installation	3
Product Specifications	4
Technical Support	5
Warranty Information	5

Introduction

Thank you for buying a StarTech.com 250-Watt replacement power supply. The ATXPOWER250 and ATXPOWR250GB are guaranteed compatible with Intel and AMD processors and designed for an extra long-life in personal and industrial computers. This power supply ensures stable system performance and uses an automatic temperature control fan to maintain an optimal operating environment for heat-sensitive components.

Features

- Ideal for Intel and AMD processors
- Provides extra power capacity for PC servers with several hard drives
- Provides the extra current required by 1 GHz and faster CPUs
- Provides the extra power required by leading edge 3D video accelerator cards
- Provides extra current and power capacity for overclocking CPUs
- Automatically detects temperature and adjusts fan speed to maintain optimal performance
- Complies with ATX version 2.03 standards
- Rear power cut-off switch
- Backed by StarTech.com's two-year warranty

WARNING! Computer parts can be severely damaged by static electricity. Be sure that you are properly grounded before opening your computer case. StarTech.com recommends that you wear an anti-static strap when installing any computer component. If an anti-static strap is unavailable, discharge yourself of any static electricity build-up by touching a large grounded metal surface (such as the computer case) for several seconds. Also make sure that your computer is turned off and unplugged before attempting to open your computer case.

Contents

This package should contain:

- 1 x ATXPOWER250 or ATXPOWR250GB power supply
- 1 x power cord

Installation

ATXPOWER250 users: Check the red power supply voltage switch before installation. It should be the same as your local power voltage. Change the voltage setting if necessary.

ATXPOWR250GB users: The power supply will automatically detect and set the proper voltage setting.

1. Make sure that your system is turned off and unplugged. Disconnect the power cord from your old power supply.
2. Open the case (consult your computer's user guide for details, if necessary).

NOTE: Before completing the next step, you may want to take note of what devices are attached to your current power supply so you know which devices need to be connected to the new power supply and where their connectors are located.

3. Disconnect all power connectors from the motherboard and the peripheral devices such as hard drives, floppy disks, etc. Make sure that there are no devices connected to your existing power supply.
4. Remove the existing power supply from your computer case and replace it with the new StarTech.com power supply.
5. Connect the power connectors to your motherboard and peripheral devices.
6. Close your computer case.
7. Connect the power cord to the StarTech.com power supply.

ATXPOWER250/ATXPOWR250GB Connectors

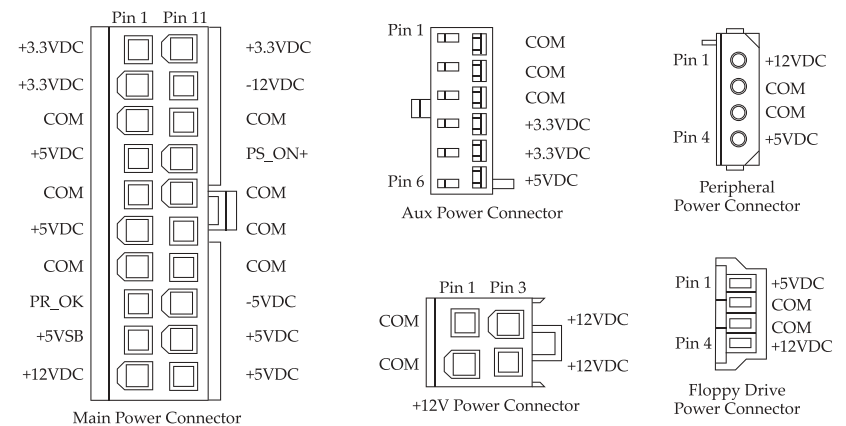

Free Manuals Download Website

<http://myh66.com>

<http://usermanuals.us>

<http://www.somanuals.com>

<http://www.4manuals.cc>

<http://www.manual-lib.com>

<http://www.404manual.com>

<http://www.luxmanual.com>

<http://aubethermostatmanual.com>

Golf course search by state

<http://golfingnear.com>

Email search by domain

<http://emailbydomain.com>

Auto manuals search

<http://auto.somanuals.com>

TV manuals search

<http://tv.somanuals.com>