

Operating Instructions

Dehumidified air dryer

STT 110

STT 160

Please note that our address and phone information has changed. Please reference this page for updated contact information.

CAUTION

These manuals are obsolete and are provided only for their technical information, data and capacities. Portions of these manuals detailing procedures or precautions in the operation, inspection, maintenance and repair of the products may be inadequate, inaccurate, and/or incomplete and shouldn't be relied upon. Please contact the ACS Group for more current information about these manuals and their warnings and precautions.

Parts and Service Department

The ACS Customer Service Group will provide your company with genuine OEM quality parts manufactured to engineering design specifications, which will maximize your equipment's performance and efficiency. To assist in expediting your phone or fax order, please have the model and serial number of your unit when you contact us. A customer replacement parts list is included in this manual for your convenience. ACS welcomes inquiries on all your parts needs and is dedicated to providing excellent customer service.

For immediate assistance, please contact:

- North, Central and South America, 8am – 5pm CST +1 (800) 483-3919 for drying, conveying, heating and cooling and automation. For size reduction: +1 (800) 229-2919.
North America, emergencies after 5pm CST (847) 439-5855
North America email: acsuscanadacustserv@corpemail.com
- Mexico, Central & South America
Email: acslatinamericacustserv@corpemail.com
- Europe, Middle East & Africa +48 22 390 9720
Email: acseuropecustserv@corpemail.com
- India +91 21 35329112
Email: acsindiacustserv@corpemail.com
- Asia/Australia +86 512 8717 1919
Email: acsasiacustserv@corpemail.com

Sales and Contracting Department

Our products are sold by a worldwide network of independent sales representatives. Contact our Sales Department for the name of the sales representative nearest you.

Let us install your system. The Contract Department offers any or all of these services: project planning; system packages including drawings; equipment, labor, and construction materials; and union or non-union installations.

For assistance with your sales or system contracting needs please Call:

North, Central and South America +1 (262) 641-8600 or +1 (847) 273-7700 Monday–Friday, 8am–5pm CST

Europe/Middle East/Africa +48 22 390 9720

India +91 21 35329112

Asia/Australia +86 512 8717 1919

Facilities:

ACS offers facilities around the world to service you no matter where you are located. For more information, please visit us at www.acscorporate.com

United States:

ACS Schaumburg – Corporate Offices

1100 E. Woodfield Road
Suite 588
Schaumburg, IL 60173
Phone: + 1 847 273 7700
Fax: + 1 847 273 7804

ACS New Berlin – Manufacturing Facility

2900 S. 160th Street
New Berlin, WI 53151
Phone : +1 262 641 8600
Fax: + 1 262 641 8653

Asia/Australia:

ACS Suzhou

109 Xingpu Road SIP
Suzhou, China 215126
Phone: + 86 8717 1919
Fax: +86 512 8717 1916

Europe/Middle East/Africa:

ACS Warsaw

Ul. Działkowa 115
02-234 Warszawa
Phone: + 48 22 390 9720
Fax: +48 22 390 9724

India

ACS India

Gat No. 191/1, Sandbhor Complex
Mhalunge, Chakan, Tal Khed,
Dist. Pune 410501, India
Phone: +91 21 35329112
Fax: + 91 20 40147576

Sterling Material Processing

5200 West Clinton Ave.

Milwaukee, WI 53223

Telephone: (414) 354-0970

Fax: (414) 354-6421

www.sterlco.com

Technical service:

Service department

Telephone: (800) 423-3183

Edition: 04/02

These operating instructions are for*:

(* Please fill in personally)

Serial number: _____

Year of manufacture: _____

Date of delivery: _____

Number of delivery: _____

Date of commissioning: _____

Location: _____

Group of machines: _____

SM2-605

Sterling Material Processing retains all rights to change the information in these operating instructions at any time without notice.

We assume no liability for any errors or direct or indirect damage resulting in context with these operating instructions.

Copying, translation or publication in any form except for personal use of purchaser requires approval from Sterling Material Processing.

All rights reserved.

Table of contents

1. General Information	1-1
1.1. Warnings and symbols	1-2
1.2. Explanations and information	1-4
1.3. Legal basis	1-4
1.4. Fields of applications	1-4
1.5. Notes on Usage	1-4
2. Safety instructions	2-1
2.1. For your safety	2-2
2.2. For the safety of the devices	2-5
3. Start up	3-1
3.1. Initial Operation	3-2
3.1.1. Switching on the Dryer	3-2
3.2. Continuous Operation	3-4
3.2.1. Switching the Dryer on	3-4
3.2.2. Setting the Drying Temperature	3-5
3.3. Switching the Dryer off	3-7
4. Error and error correction	4-1
5. Maintenance	5-1
5.1. Maintenance schedule	5-3
5.2. Cleaning or Replacing the Air Filter	5-4
5.2.1. Cleaning or Replacing the Return Air Filter	5-5
5.3. Disposing of Drying Agents	5-6
5.3.1.	5-6
5.3.2.	5-6
5.3.3.	5-6
5.3.4.	5-6
5.3.5.	5-6
5.3.6.	5-6
5.3.7.	5-6
5.3.8.	5-6
5.3.9.	5-6
5.4. Cleaning the Drying Hopper	5-7
6. Functional description	6-1

6.1. General Information	6-2
6.2. Drying Hopper (Optional)	6-5
6.2.1. Hopper Heater	6-6
6.3. Connection to a Pneumatic Conveying System (Optional)	6-7
6.4. Return Air Cooler (Optional)	6-7
7. Transport, Assembly and Storage	7-1
7.1. Transport and Packing	7-2
7.2. Assembly	7-3
7.3. Storage	7-3
8. Assembly instructions	8-1
8.1. Installation of the exhauster fan for regeneration of exhaust air	8-2
8.2. Grounding the equipment against electrostatic charging	8-2
8.3. Electrical Connection	8-3
8.4. Connection of Return Air Cooler (Optional)	8-4
9. Technical Data	9-1
9.1. STT 110	9-1
9.2. STT 160	9-2
9.3. Dimension Sheet	9-3
10. Spare parts list	10-1
11. Electrical manual	11-1
<input type="checkbox"/> Connection diagram no.: _____	
<input type="checkbox"/> Currently not available; will be delivered at a later date !	
12. Accessories	12-1
<input type="checkbox"/> Basic setting thermo regulator	
<input type="checkbox"/> Digital timer	
<input type="checkbox"/> _____	
<input type="checkbox"/> _____	
<input type="checkbox"/> _____	

1. General Information



These operating instructions are addressed to all users of the device.

These operating instructions must be used by every person charged with work on the unit.

1.1. Warnings and symbols

The following warnings and symbols are used in these operating instructions:



This symbol indicates danger to life! Fatal or serious injury is possible if the corresponding instructions, regulations or warnings are not observed.



This symbol indicates that serious injury is possible if the corresponding instructions, regulations or warnings are not observed.



This symbol indicates that extensive damage to equipment is possible if the corresponding instructions, regulations or warnings are not observed.



This symbol indicates information important for becoming familiar with the equipment, i.e. technical correlations.



This symbol indicates that a technical term is explained at this point.



When disposing of drying agents / batteries / oil, observe all official rules.



Caution: High noise pollution !
For all work on the equipment, hearing protection should be worn.
Avoids impairment of hearing!



Caution: Danger of crushing !
Disconnect the equipment from mains supply before starting maintenance procedures. All compressed air pipes on the equipment should be depressurised before starting maintenance work.



Caution: Danger of hot surface !
Before starting any work wait until all parts have been cooled down sufficiently. Avoid touching any of these parts!



Caution: Danger of skidding !
Remove any granules remaining on the ground.



Caution: Danger to life through electrical shock !
Observe that the control system is still under voltage even when the main switch is switched off.

1.2. Explanations and information

Various terms and designations are used in these operating instructions to ensure clarity. Therefore please note that the terms used in the text stand for the corresponding explanations listed below.

- **Equipment**
"Equipment" can mean an individual unit, a machine or an installation.
- **Operating personnel**
The "operating personnel" are persons operating the equipment on their own responsibility or according to instructions.
- **Operator**
The "operator" of the equipment (production manager, foreman, etc.) is the person responsible for all production sequences. The operator instructs the operating personnel of what is to be done.
- **Operating instructions**
The "operating instructions" describe the interaction of the equipment, production sequences or methods. The operating instructions must be compiled by the operator of the equipment.
- **Equipment foreman**
When several operating personnel work on one machine, the "equipment foreman" coordinates the sequences. The equipment foreman must be appointed by the operator.
- **Trained personnel**
"Trained personnel" are persons who, due to their training, are authorized to carry out the required work.

1.3. Legal basis

See "Manufacturer's Certificate" resp. "Certificate of Conformity".

1.4. Fields of applications

For the drying of thermoplastic granules and regrind before processing in order to remove all remaining moisture from the granules both inside and out, independent of climate or ambient air conditions.

1.5. Notes on Usage

- Experienced operators can begin directly with the chapter on "Start-up" if the unit has been properly installed.
- If the unit has not been installed yet, observe the instructions in the chapter on "Assembly Instructions" and "Transport, Assembly and Storage".

2. Safety instructions



These safety instructions apply to all persons within the range of action of the equipment.

Please inform all persons within the range of action of the equipment of the direct and indirect hazards connected with the equipment.

These operating instructions are to be used by all persons assigned activities connected with the equipment.

Knowledge of the English language is prerequisite.

Ensure in each case that the operating personnel are familiar with the operating instructions and the function of the equipment.

2.1. For your safety

General

The operating personnel of this equipment must be at least 16 years old.

Please read these operating instructions carefully before taking into operation for the first time. Contact us should questions arise. This avoids injury and damage to equipment!

These operating instructions must be kept available at all times at the place of operation of the equipment. Improper operation results in danger of accidents!

Please note that, for reasons of clarity, not all conceivable cases regarding operation or maintenance of the equipment can be covered in these operating instructions.

Please observe all safety instructions and warnings on the equipment. This avoids injury and damage to equipment!

All work on the equipment is to be carried out by persons whose qualifications are specified in the pertaining chapters of the operating instructions. Improper operation results in danger of accidents!

The proper working clothes are to be worn during any work on the equipment. This avoids injury!

The local regulations and requirements pertaining to this equipment must be observed.

Disconnect electrical components from the mains supply before work is carried out on these components. Caution: Danger to life through electrical shock!

Compile detailed operating instructions based on these Operating instructions for the sequence of procedures to be carried out on this equipment. Improper operation results in danger of accidents!

Observe that the control system is still under voltage even when the main switch is switched off. Caution: Danger to life through electrical shock!

Assembly

Compare the connected loads with those of the mains supply. Danger of injury through electrical shock!

When using lifting gear, please observe the pertaining regulations. Caution: Danger of accidents!

Do not modify, add other equipment or change the design of the equipment without the approval of the manufacturer. Caution: Danger of accidents!

Attachments not supplied by Sterling must be manufactured in accordance with safety regulation EN 294. Danger of accidents!

The equipment may only be operated when all the associated components are properly connected up and in accordance with the relevant regulations. This avoids injury and damage to equipment!

Operate the device only if all its components are grounded. Danger: accident through electrical shock!

Please note for installation that the equipment is top-heavy. Danger exists that it may topple over!

Take care that the device is not standing on the mains cable. This will prevent danger to people and material!

Operation

Appoint an equipment foreman to be responsible for the equipment.

Ensure that the operating personnel are provided detailed instruction in the operation of the equipment. Improper operation results in danger of accidents!

When the main switch is switched off for reasons pertaining to safety, it must be secured against unauthorized activation. Caution: Danger of accidents!

Repair work may be carried out by trained personnel only. Caution: Danger of accidents!

Never operate the equipment when partially dismantled! Danger! Limbs may be caught in machinery! Electric shock!

In case of malfunction, shut down the equipment immediately. Have malfunctions corrected immediately. Danger of accidents!

The machine is intended only for the drying of granulated plastics. Any other or additional use is contrary to specifications.

This equipment is not suitable for food processing.

The safety instructions of the connected machines must be followed.

Please note that sound levels exceeding 85 db(A) may in the long term damage your health. Use the appropriate ear muffs. This avoids impairment of hearing!

Please note that the drying cells, drying hoppers and air pipings grow hot during use. Avoid touching any of these parts! Danger: Injury through burns!

Never operate the dryer without side panels. Danger: Limbs may be caught in machinery! Injury through burns!

Operate the dryer only if there is at least one drying hopper operating. This will prevent damage of material!

When drying plastics which emit gases dangerous for human health, take care that the regeneration exhaust air is disposed of without polluting the environment. This will prevent danger to people and material!

Maintenance

Before starting maintenance work, appoint a supervisor.

Inform the responsible personnel before maintenance work on the system is started. Caution: Danger of accidents!

Disconnect the equipment from mains supply before starting maintenance procedures to ensure that it cannot be switched on unintentionally. Caution: Danger of accidents!

All pipes, hoses and screwed connections should be checked regularly for leaks and damage. Any faults which arise should be corrected immediately. Danger of accidents!

Depressurize all compressed air piping before starting maintenance work. Danger of accidents!

The air filters should only be cleaned/replaced when the the main switch is off and the blower has stopped. This avoids injury and damage to equipment!

Any maintenance work on the equipment should only be started when the the main switch is off and the blower has stopped. This avoids injury and damage to equipment!

Check the v-belts of the blower only when the main switch is switched off and the blowers have stopped. Caution: Danger of accidents!

Open drying hoppers only if they are completely empty. Danger of accidents!

Never open drying hoppers while the device is in operation. Danger: Injury through burns!

Open drying hoppers only if they have been cooled down sufficiently. Danger: Injury through burns!

Before starting maintenance work wait until the drying cells, drying hoppers and air pipings have been cooled down sufficiently. Avoid touching any of these parts! Danger: Injury through burns!

Remove any granules remaining on the ground. Danger of accidents!

Arrest the wheels after installation if the dryer is mounted on a movable frame. This will prevent danger to people and material!

2.2. For the safety of the devices

Never change settings without carefully assessing the consequences.

Use only original Sterling spare parts.

Observe the maintenance instructions.

Keep a record of all maintenance works and repairs.

Please note that electronic components can be damaged by static discharge.

Before initial operation and in regular intervals, make sure that no electrical connections are loose.

Never readjust sensors without exactly knowing their functions.

Please ensure that the permitted storage temperature lies between 0 and +55 °C (32 to +131 °F).

Please ensure that the permitted operation temperature lies between 0 and +45 °C (32 to +113 °F).

Check the direction of rotation of the blowers after the electrical connections have been made (see rotational direction arrow).

Clean the drying hoppers before the first filling.

Note the instructions of the material manufacturer for the maximum drying temperature.

Note the drying instructions of the material manufacturer.

Take care that the drying hoppers are always completely filled and that the retention period is respected if continual removal is taking place.

Note that too large amounts taken from the drying hopper lead to insufficient drying of the material.

Close the air stop valves of drying hoppers which are empty or have not been used.

Note down all data which you have entered into the control system.

The password is to be entrusted to authorised personnel only.

Please note that the temperature of the dryer heating system must always be set lower than that of the supplementary heaters.

When you dispose of drying agents, observe all official rules.

Note that drying cells are replaced or refilled by Sterling only if they are empty.

The material level may not fall below 40 % in the drying hopper, when material is continuously removed from the drying hopper, but no material is continuously fed into the drying hopper (batch drying). Close the throttle valves.

Read the operating manuals of the connected devices.

3. Start up



This chapter is addressed to the operators of the machine.

This chapter assumes general skills with drying equipment.

This chapter assumes that the functional description has been read and understood.

It must be ensured that the operators have the required experience.



Make sure that the main switch is at "0" position.

Check the drying hopper for cleanliness.

Check to see whether the adhesive film on the drying hopper has been removed.

If there is a return air cooler, switch on its coolant circuit.

If there is a timer clock (optional), adjust it. Read the operating manual of the timer clock.

Check whether the release switch "Timer" and the release switches "Hopper" (ST1 - ST6) are at "0" position.



The signal lamp "trouble" may flash shortly while the valve block is changed.

3.1. Initial Operation

Check whether the inlet of the drying hopper is closed by a blind lid, or whether a conveyor unit (optional) is installed.

If not, manufacture a suitable blind lid and install it on the inlet of the drying hopper or install the conveyor unit (optional).



Attachments which are not supplied by Sterling must be manufactured according to the safety regulation European Standard 294.

Check whether the coolant circuit of the return air cooler is turned on (if a return air cooler is installed).

3.1.1. Switching on the Dryer

Switch on the main switch of the dryer.



The signal lamp "power" goes on.

For operation with timer clock (optional):

Turn the release switch "Timer" at position:



For operation without timer clock:

Turn the release switch "Timer" at position:



The blower is running.



If the dryer has not been in use for several months it must be operated for about 2 hours without material.

Turn the release switches "Hopper" (ST1 - ST6) at "1" position.

Turn the thermo regulator to +80 °C (176°F) for the drying temperature.

Press the "PGM" key.



Set by means of the arrow keys the drying temperature to "80".

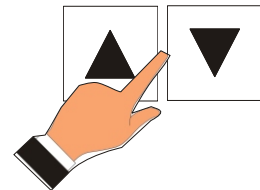

After 2 seconds the display flashes and the value is stored.

Press the "EXIT" key (the setpoint value and the actual value of the drying temperature are displayed).



After 2 hours turn the release switches "Hopper" (ST1 - ST6) at "0" position.

Turn the release switch "Timer" at position:



Wait until the blower has stopped.
The run on time of the blower is 10 minutes.

If there is a return air cooler installed, switch off its coolant circuit.

Switch off the main switch of the dryer.



The signal lamp "power" goes off.

3.2. Continuous Operation



Fill at least half of the drying hopper with material.

3.2.1. Switching the Dryer on

Switch on the main switch of the dryer.



The signal lamp "power" goes on.

For operation with timer clock (optional):

Turn the release switch "Timer" at position:



For operation without timer clock:

Turn the release switch "Timer" at position:



The blower is running.

3.2.2. Setting the Drying Temperature

Turn the release switches "Hopper" (ST1, ST2) at "I" position.

For each drying hopper, set the required drying temperature (= desired value) by means of the respective thermo regulator.

Check whether the set drying temperature is appropriate for the materials which have been filled in.

Observe the instructions of the material manufacturer.

After the first filling, process the material only after the retention period is over.

Observe the instructions of the material manufacturer.

Press the "PGM" key.



By means of the arrow keys select the desired value for the drying temperature.

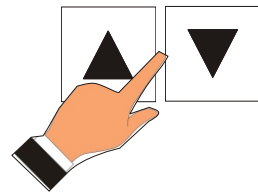

After 2 seconds the display flashes and the value is stored.

Press the "EXIT" key (the setpoint value and the actual value of the drying temperature are displayed).



After a change of materials, immediately check and correct the set drying temperature.

Optimizing the thermo regulator

Press the "EXIT" key for at least 2 seconds.



"tunE" flashes. The optimization can take several minutes.

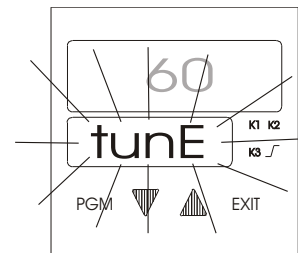

If "tunE" stops flashing, the optimization is finished.

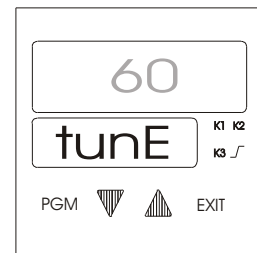

Press the "EXIT" key.



3.3. Switching the Dryer off

Set the release switch "Timer" at position:



Wait until the blower has stopped.
The run on time of the blower is 10 minutes.

If there is a return air cooler installed, switch off its coolant circuit.

Switch off the main switch of the dryer.



The signal lamp "power" goes off.

4. Error and error correction



This chapter is directed at the operators of the equipment.

This chapter assumes general skills in dealing with drying systems.

This chapter assumes that the “start-up” description has been read and understood.

It should be ensured in each and every case that the operators have the relevant skills.



Faults must be eliminated before the control system can again start operating.



An alarm is indicated by steady light of the signal lamp “trouble”.

When the fault has been eliminated, the signal lamp “trouble” goes off.

The following errors can lead to an alarm:

Blower

The pressure of the blower is too low.
Check the blower.
Vacuum sensor defective.

Regeneration heater 1

The safety temperature limiter of the regeneration heater 1 has been activated.
Check the safety temperature limiter.
Sterling Service.

Regeneration heater 2

The safety temperature limiter of the regeneration heater 2 has been activated.
Check the safety temperature limiter.
Sterling Service.

Hopper heater

The safety temperature limiter of the hopper heater has been activated.
Check the safety temperature limiter.
Sterling Service.

5. Maintenance



This chapter is intended for persons with skills in electrical and mechanical areas due to their training, experience and received instructions.

Personnel using the instructions in this chapter must be instructed of the regulations for the prevention of accidents, the operating conditions and safety regulations and their implementation.

Ensure in each case that the personnel are informed.

For maintenance work taking place at heights of over approx. 1829 mm (6 ft.), use only ladders or similar equipment and working platforms intended for this purpose. At greater heights, the proper equipment for protection against falling must be worn.

Use only suitable lifting gear which is in proper working order and load suspension devices with sufficient carrying capacity. Do not stand or work under suspended loads!

Ensure that the electric motors/switch cabinets are sufficiently protected against moisture.

Use suitable workshop equipment.

Before starting maintenance work, appoint a supervisor.

Inform the responsible personnel before maintenance work on the system is started.

Never operate the equipment when partially dismantled.

Any maintenance and repair work NOT described here may only be carried out by Sterling service personnel or by specialised staff authorised by Colortronic.



Disconnect the equipment from mains supply before starting maintenance procedures to ensure that it cannot be switched on unintentionally.

All compressed air pipes on the equipment should be depressurised before starting maintenance work.



Please observe the maintenance schedule.

Before starting maintenance work, clean the equipment of oil, fuel or lubricant.

Ensure that materials and incidentals required for operation as well as spare parts are disposed of properly and in an environmentally sound manner.

Use only original Sterling spare parts.

Keep record of all maintenance and repair procedures.

5.1. Maintenance schedule

Daily:	Check warning signs on equipment for good legibility and completeness Clean return air filters and casing (depending on dust build-up)
Weekly:	Check main switch for proper function Check the signal lamps for proper functioning
Every six months:	Change return air filters (depending on dust build-up) Clean air filter of the suction box All electrical and mechanical connections should be checked to see if they fit securely
Annually:	Dewpoint should be checked (only by Sterling service personnel)
Whenever the material is changed:	The drying hopper and suction box must be cleaned



The service intervals refer to a 3-shift operation.



The given maintenance intervals are average values.

Check whether in your individual case the maintenance intervals must be shortened.

5.2. Cleaning or Replacing the Air Filter

Set the release switch "Timer" at position:



Wait until the blower has stopped.
The run on time of the blower is 10 minutes.

If there is a return air cooler installed, switch off its coolant circuit.



Switch off the main switch of the dryer (the signal lamp "power" goes off).
Interrupt the mains supply so that the device cannot be switched on unintentionally.



Clogged filters substantially reduce the amount of circulating air and lead to a production lag of your dryer. Clogged filters may also damage the heating elements.

5.2.1. Cleaning or Replacing the Return Air Filter

STT 110 / STT 160

Detach the nut on the housing of the return air filter and remove the housing cover.

Remove the nut of the filter cartridge.

Remove the filter cartridge.

Clean the inside of the return air filter housing. Use non-fibrous cleaning cloths or an industrial type vacuum cleaner.

Blow compressed air from the inside out through the clogged filter cartridge **or** replace the filter cartridge.

Re-install the cleaned/new filter cartridge.

Mount the nut.

Install the lid of the return air filter housing.

Fix the nut.

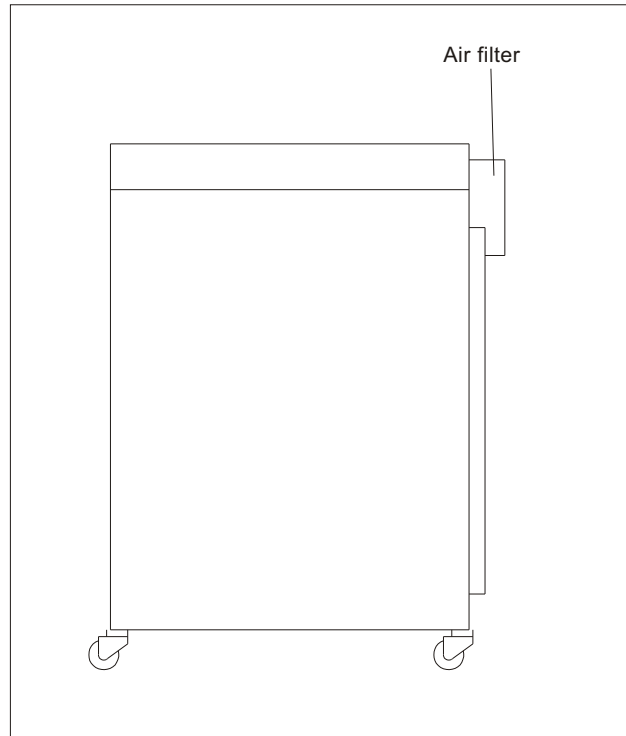

STT 110 / STT 160



Never operate the dryer without return air filter.



Purchase order numbers return air filter
when operating without return air cooler: ID 88366
when operating with return air cooler: ID 88628

5.3. Disposing of Drying Agents

Please note that drying cells are replaced or refilled by Sterling only if they are empty.



When disposing of drying agents, observe all official rules.

Since used drying agents may contain impurities from the dried materials, treat them as special waste.



It is not possible for Sterling to take back the used drying agent or drying cells with used drying agents.

5.3.1.

5.3.2.

5.3.3.

5.3.4.

5.3.5.

5.3.6.

5.3.7.

5.3.8.

5.3.9.

5.4. Cleaning the Drying Hopper

Set the release switch "Timer" at position:



Wait until the blower has stopped.
The run on time of the blower is 10 minutes.

If there is a return air cooler installed, switch off its coolant circuit.



Switch off the main switch of the dryer (the signal lamp "power" goes off).
Interrupt the mains supply so that the device cannot be switched on unintentionally.



Clean the drying hopper each time you are changing the materials.
Make sure that the drying hopper has cooled down sufficiently.
Make sure that the drying hopper is completely empty.
Remove any granules remaining on the ground.

ST 25

Open the toggle-type fasteners (A) at the hopper lid and fold the hopper lid upwards (if in use: remove before the single conveyor).

Clean the drying hopper.

Close the hopper lid and close the toggle-type fasteners (A) (if in use: re-mount the single conveyor).

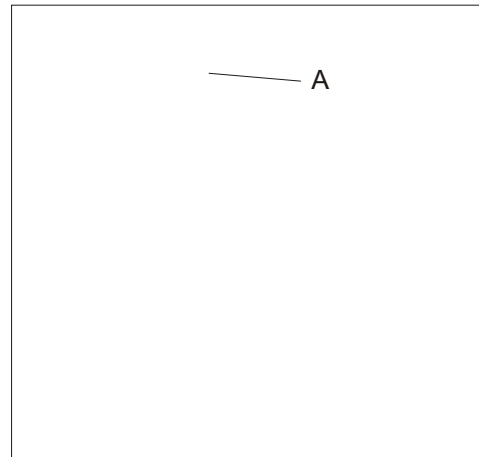

TT 25



Remove any granules remaining in the cleaning opening.

ST 60 - ST 1600

Open the cleaning opening of the drying hopper: Lift and turn the handle (A) to open the lock, if in use: remove before the single conveyor (ST 400 - ST 1600: 2 handles).

Clean the drying hopper.

Close the cleaning opening of the drying hopper: Turn the handle (A) until the cleaning opening is locked and then close the handle (if in use: re-mount the single conveyor).



Remove any granules remaining in the cleaning opening.
ST 1200 and ST 1600: Clean the bead.

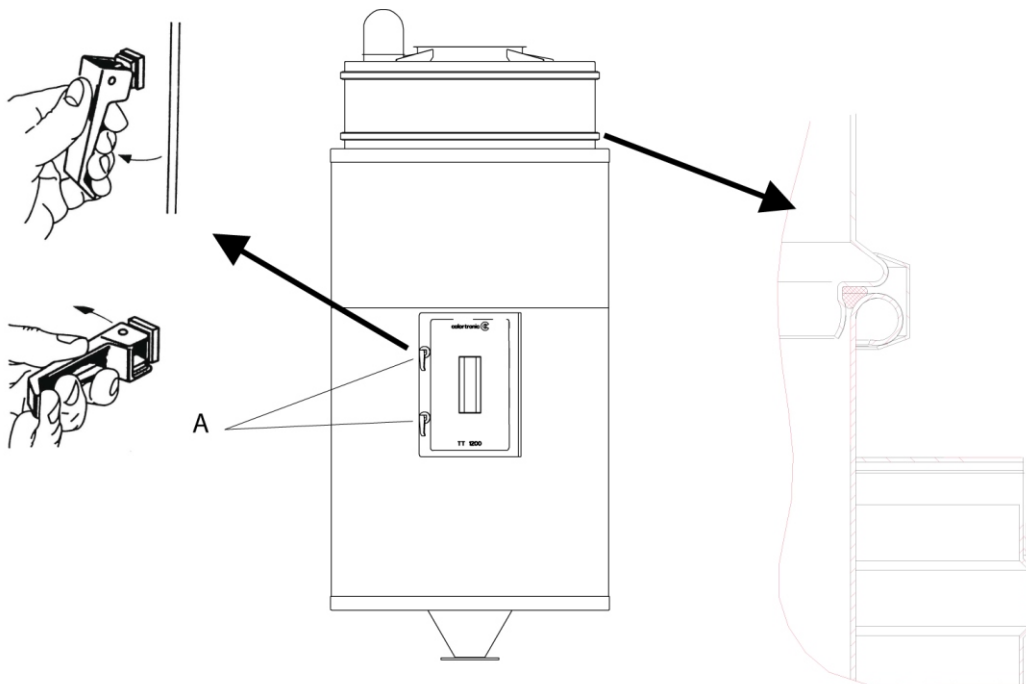

ST 60 - ST 1600

6. Functional description



This functional description is addressed to the operators of the equipment.

This functional description assumes general familiarity with drying equipment.

It should be verified that the operators do indeed have the appropriate skills.

6.1. General Information

The dehumidified air dryers were developed for drying plastic granules. Due to their compact construction, they can be employed next to the processing machine (drying hopper on the processing machine) or with one or more drying hoppers as a movable facility (compact facility).

The dryers work according to the dehumidified air principle, i.e., the air is not only heated but also dehumidified before it flows through the drying hopper.

In this manner, plastic granules can be dried down to a very small residual moisture content.

The drying temperature can be adjusted, if necessary, up to a maximum of +180 °C (356°F) (upper limit). Due to the heat that is released during water absorption in the drying cells, the lower limit of the dehumidified air temperature is approx. +60 °C (140°F).

The drying takes place continuously, i.e., there are no rest periods due to regeneration of the drying agent.



The dryer is rated for continuous operation.

The dryer may only be put into operation if the drying hopper is filled.

All function sequences are fully automatic.

The dryer is equipped with two drying cells. One drying cell is part of the drying cycle; the other drying cell is regenerated simultaneously.

Part of the dehumidified air is used for regenerating the moist drying cell. At the beginning of regeneration, it is heated by the regeneration heater. After the end of the heating period, the drying cell is cooled off by means of dehumidified air. After the switch-over time is reached, the regenerated drying cell is included in the drying cycle, and the cycle starts again.

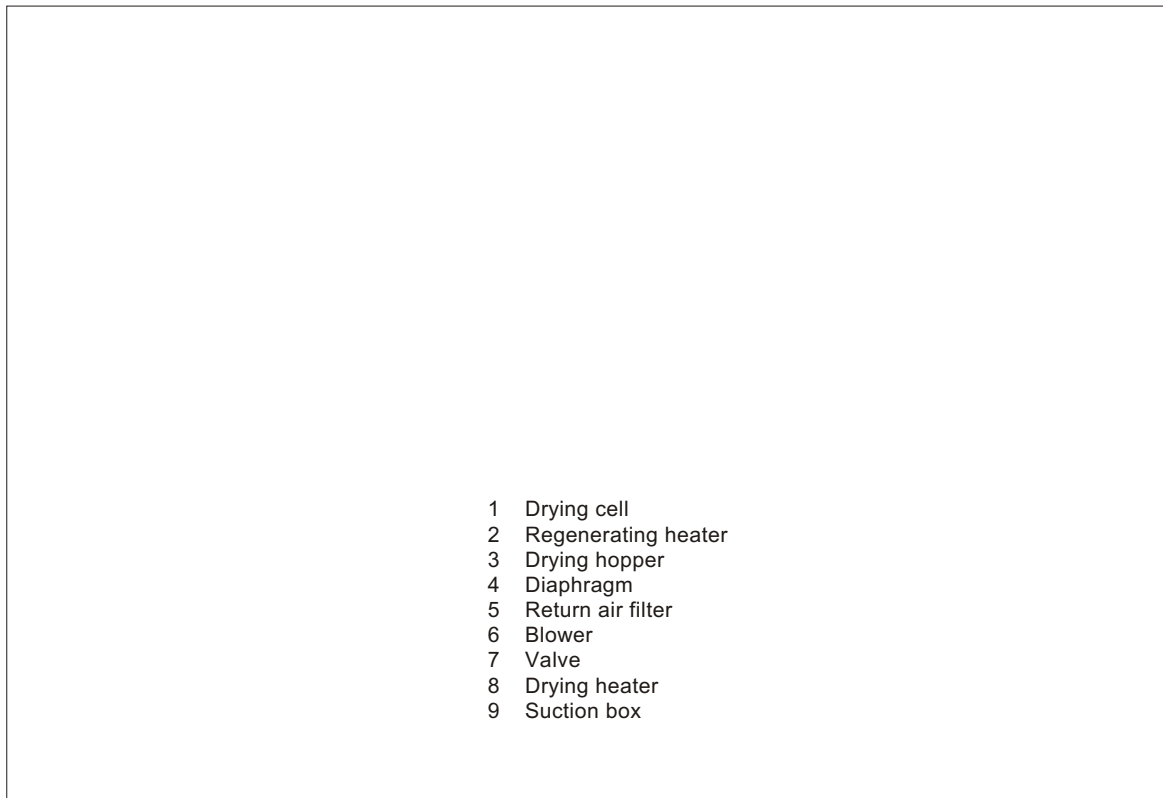

Functional diagram

A digital display of the current dew point temperature can be supplied as additional equipment. As an option, a timer clock can be supplied which switches the dryer on or off at preselected times.



Read the operating manual of the timer clock.

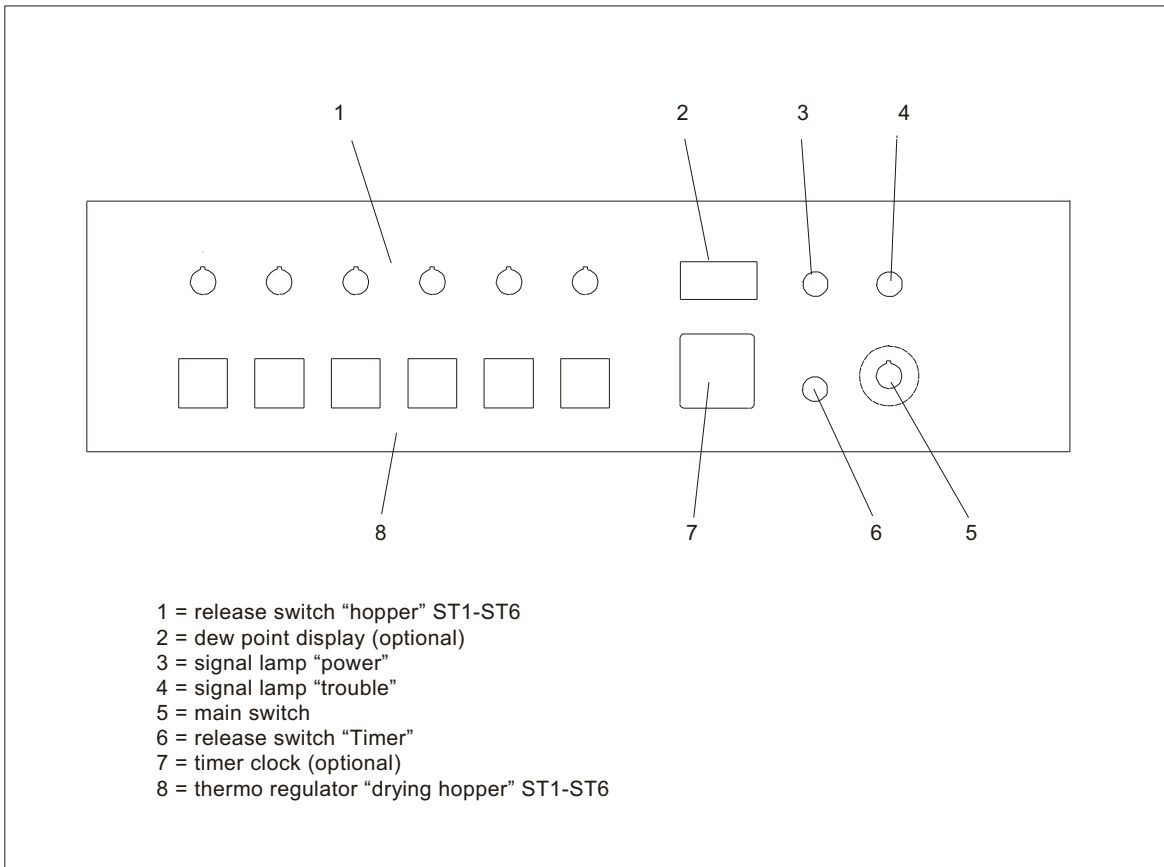

Operating unit

6.2. Drying Hopper (Optional)

The material is dried in the drying hopper. The dehumidified air is conducted through the material in the drying hopper and takes up moisture. Drying hoppers must have the appropriate dimensions for their specific use so that the desired final moisture content is reached. When refilling a drying hopper, the material must first be dried completely before material can be taken out for the first time.

If material is taken out continuously, there must also be a continual addition of material into the drying hopper (continuous drying process). New (moist) material is conducted into the upper opening of the drying hopper and slowly reaches the material outlet at the lower end. On its way from the upper to the lower end, the material is dried down to the final moisture content.

In order to guarantee a continuous drying process, we recommend that you always keep the drying hopper filled completely.

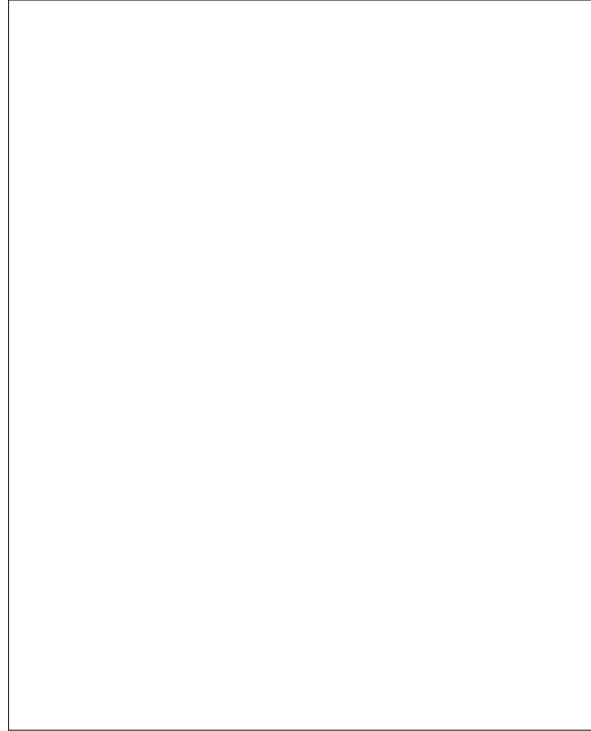

Drying Hopper

6.2.1. Hopper Heater

Each drying hopper has its own hopper heater. The temperature of the dehumidified air is adjusted by means of the thermo regulator. The setting range is from +60 - +180 °C. The current temperature can be read off the digital display (= actual value).



The thermo regulator is factory-programmed. Nevertheless, you have to set specific values which are dependent on the processed material.

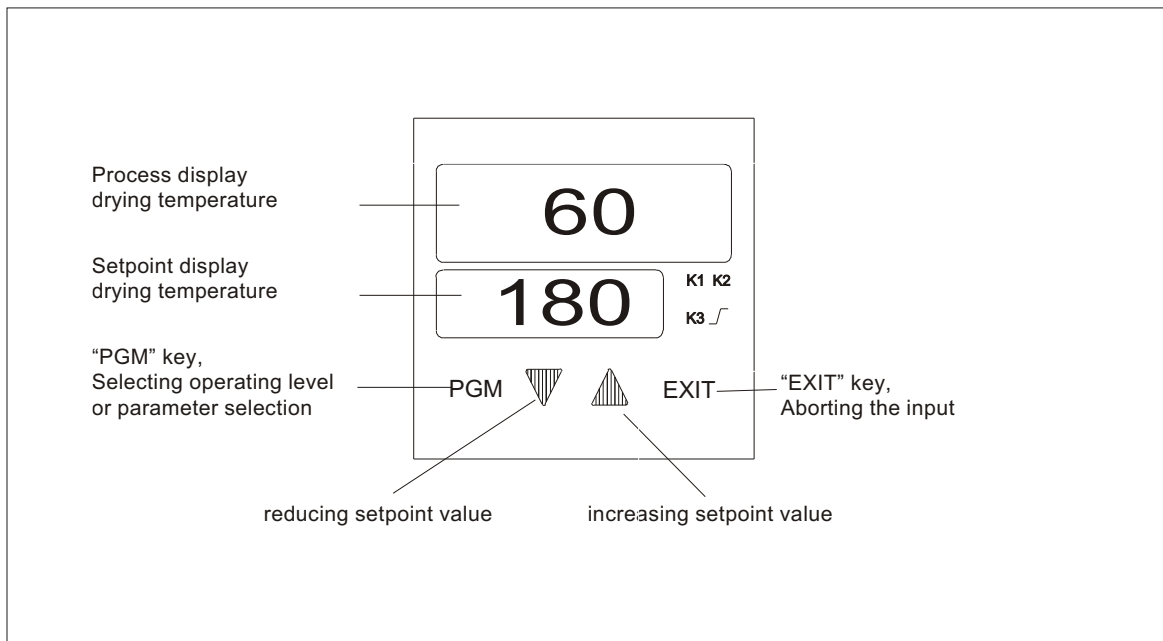

Thermo regulator

6.3. Connection to a Pneumatic Conveying System (Optional)

Your drying facility works best in combination with a pneumatic conveying system. In this way, your drying hopper will always be supplied with sufficient material.

The facility will only take as much material as is required by the processing machines. Therefore, the drying result will always be the same.

Sterling drying hoppers are equipped with a suitable flange for adding a Sterling pneumatic conveyor.

Suction boxes with one or three suction tubes can be supplied as well (optional). These suction boxes are developed specifically for this type of hopper.

The loading of the conveying line with material is adjusted by closing or by opening of the control cover (A).

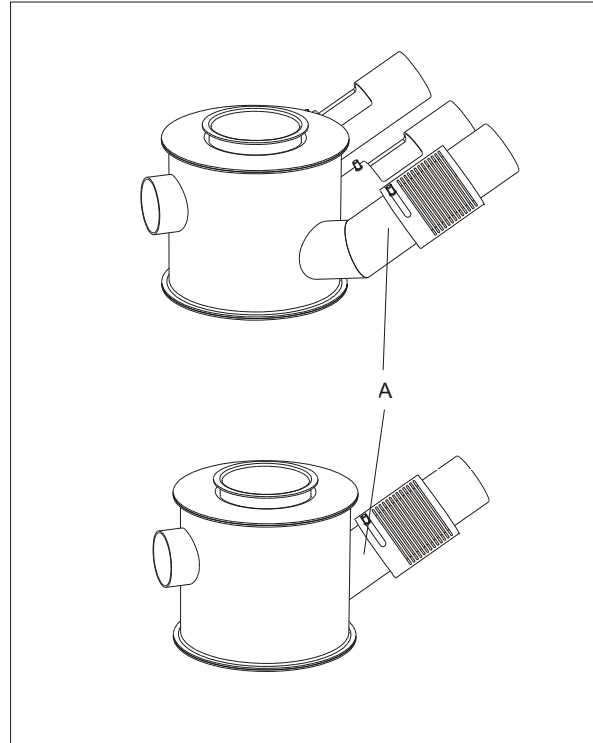

Suction box

6.4. Return Air Cooler (Optional)



A return air cooler must be employed if the return air temperature is higher than +65 °C (149°F).

A return air cooler improves the efficiency of the drying cells.



The lower the return air temperature, the better the efficiency of the drying cells.

The return air cooler can be connected to a coolant circuit or to the water mains network.

7. Transport, Assembly and Storage



This chapter is intended for all operating personnel of the equipment.

Personnel using these instructions must be instructed in the regulations for the prevention of accidents, the operating conditions and safety regulations and their implementation.

Ensure in each case that the operating personnel are sufficiently informed.

Please inform all persons within the range of action of the equipment of the direct and indirect hazards connected with the equipment.

Please observe all safety regulations for the operation of lifting equipment.

7.1. Transport and Packing



Please ensure adequate carrying capacity of the lifting equipment.
Note that the dryer system is top-heavy. Risk of toppling!



The machine must not be tilted or laid on its side.

The equipment pass a rigorous operating test in the factory and are packed carefully to avoid transport damage.

Please check packing on delivery for transport damage.

The inlet and discharge flanges are sealed with plugs, so that no dirt can enter during transport. Plugs must be removed before assembly.

Packing materials should be disposed of according to environmental laws or reused.

The dryer or the compact unit is delivered on a pallet.

The dryer should only be moved by means of the appropriate lifting equipment (e. g. a fork lift truck or a workshop crane).

Fasten the transport cables to the eyelets of the control cabinets.

Transport must be shock-proofed and free from vibrations.

7.2. Assembly



Please ensure adequate carrying capacity of the lifting equipment.

Check the carrying capacity of the point of installation, particularly if installed on a platform.

The place selected for installation should be as free of vibrations as possible.

The main switch must be freely accessible.

Ground the equipment against electrostatic charging.



The machine must not be tilted or laid on its side.

Because of its compact construction the dryer can be installed directly beside the processing machine (drying hopper on the processing machine) or with one or more drying hoppers as a movable facility (compact facility).

Special foundations are not necessary for installation.

The dryer must be installed on a level surface and must not be exposed to excessive humidity. The maximum permissible ambient temperature is 45 °C (113°F).

To facilitate servicing, the dryer should be installed in such a way that that it is accessible from 3 sides. Make sure that the air filters can be changed without problems.

To conserve energy, keep the distance between dryer, hopper and processing machine as small as possible.

The wheels of the compact unit should be locked to ensure stable installation.

The foil should be removed from the drying hopper.

7.3. Storage

The control system may only be stored at temperatures from 0 to +55°C (32 to +131 °F).

Between delivery and machine commissioning the equipment should be stored in a dry, dust-free and vibration-free room.

8. Assembly instructions



These installation instructions are intended for persons with skills in electrical and mechanical areas due to their training, experience and received instructions.

Personnel using these installation instructions must be instructed in the regulations for the prevention of accidents, the operating conditions and safety regulations and their implementation.

Ensure in each case that the personnel are informed.

The installation instructions provided in the corresponding operating instructions apply for all connected equipment.

Observe safety regulations with regard to lifting gear handling.

All installation work must be carried out with the equipment disconnected from electrical power and compressed air supply.



For installation work taking place at heights of over approx. 6 feet (1829 mm), use only ladders or similar equipment and working platforms intended for this purpose. At greater heights, the proper equipment for protection against falling must be worn.

Use only suitable lifting gear which is in proper working order and load suspension devices with sufficient carrying capacity. Do not stand or work under suspended loads!

Use suitable workshop equipment.



Install the equipment such that all parts are easily accessible; this facilitates maintenance and repair work

8.1. Installation of the exhauster fan for regeneration of exhaust air

When plastics are being dried that release harmful gases during the drying process, care must be taken that the regeneration exhaust air is disposed of in an environmentally sound way. At the same time the throughput of the regeneration blower must not be altered. It should be noted when assembling a disposal system (e.g. an exhauster system) that the regeneration exhaust air is very humid. Thus condensation may form, which must not under any circumstances return to the dryer.

8.2. Grounding the equipment against electrostatic charging

Considerable electrostatic charging may occur in the equipment during processing of the various materials. For this reason, all components must be sufficiently grounded, see grounding bolt dryer (A) and drying hopper (B).

Ensure that the regulations of the local electric supply company are observed.

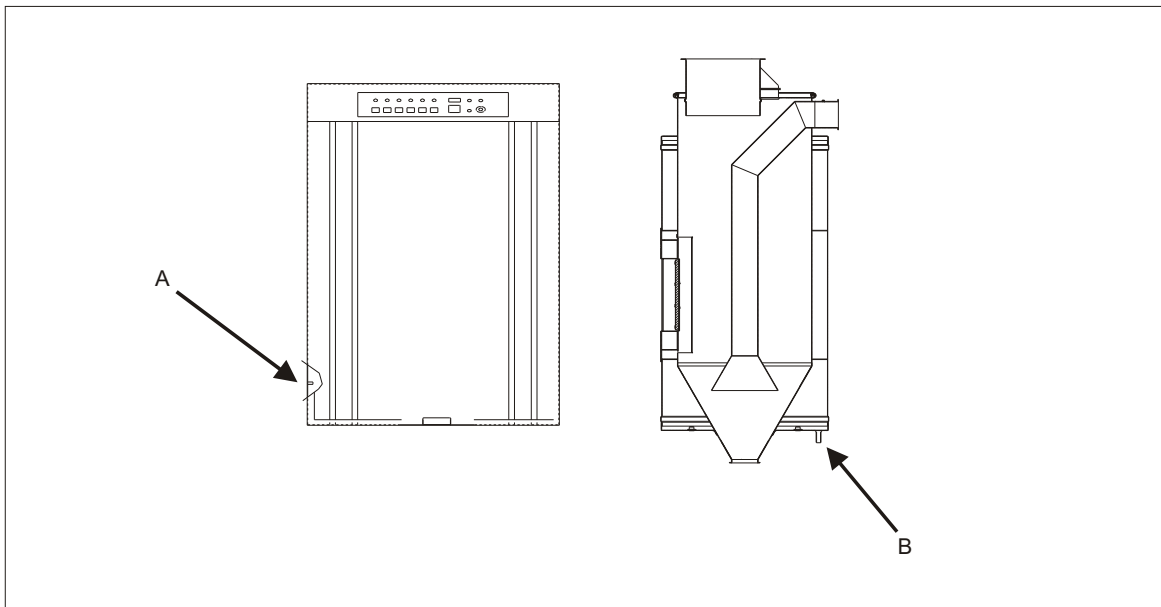

Grounding the equipment

8.3. Electrical Connection



The electrical connection of the dryer and of the hopper heaters may only be carried through or assigned by Sterling service staff or by qualified staff authorized by Sterling.

Other persons are not permitted to carry through the electrical connection.

Observe the rules of the local electricity board.

The main switch must be freely accessible.

Ground the equipment against electrostatic charging.



Regularly make sure that none of the electrical or screw connections are loose.

Make sure that the main switch is at "0" position before the electrical connection is carried out.

The operating voltage is 480/3/60

Special voltages can be supplied on request.

The connected loads* are

STT 110 approx. 3.2 kW;

STT 160 approx. 3.6 kW.

*If hopper heaters are installed, the value of each hopper heater must be added to these connected loads (max. 9.0 kW).

The fuse protection must have 32 A.

8.4. Connection of Return Air Cooler (Optional)



A return air cooler must be employed if the return air temperature is higher than +65 °C (149°F).

You can connect the return air cooler to a coolant circuit or to the water mains network.

The water flow rate in the water mains network* is for:

STT 110..... approx. 0.35 m³/h (12.46 cf/h)

STT 160..... approx. 0.48 m³/h (17.05 cf/h)

(* water temperature: +6 °C) (42.8°F)

Rate your coolant circuit accordingly.

Connect the coolant in- and outlets to the return air cooler.

Observe the flowing direction of the coolant.

Check the tightness of the connections.

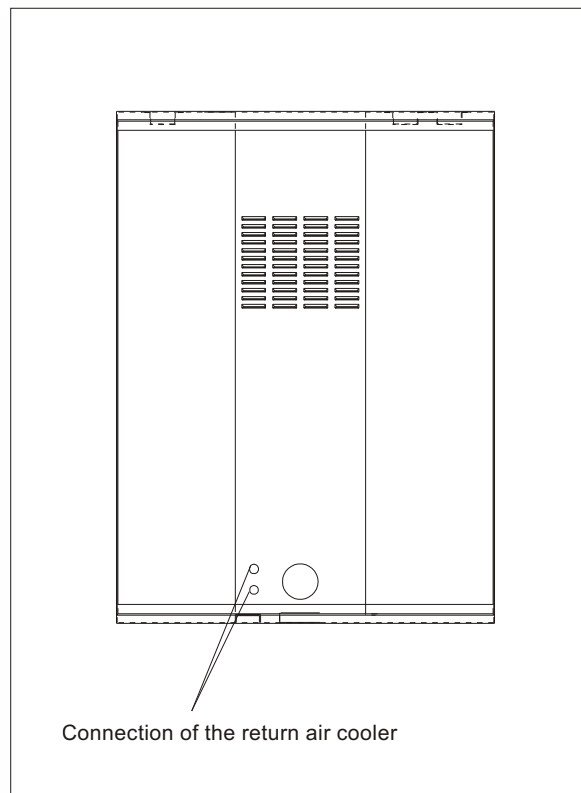

STT 110 / STT 160

SM2-605

9. Technical Data

9.1. STT 110

amount of dehumidified air:	max. 110 m ³ /h (3,8846.1 cf/h)
operating voltage:	400 V/3 AC/50 Hz
special voltages can be supplied on request	
connected load:	3.2 kW
calorific output (drying)*:	max. 9.0 kW
*depending on the equipment with hopper heaters	
calorific output (regenerating):.	2.4 kW
driving power (drying, regenerating):	0.75 kW
drying temperature:	max. +180 °C(356°F)
width:	900 mm (35.5 in.)
depth:.	666 mm (26.2 in.)
height:	1320 mm (52.0 in.)
weight:	approx. 180 kg (396.83 lbs.)
noise:	approx. 66 dB (A)
options:	timer clock
.	dew point display
.	return air cooler

Return Air Cooler

water flow rate in the water mains network*:.	approx. 0.35 m ³ /h (12.46cf/h)
(* water temperature: +6 °C) (42.8°F)	
Ø pipe connection:	1/2" (0.5 in.)

9.2. STT 160

amount of dehumidified air: max. 160 m³/h (5,650.35 cf/h)
operating voltage: 400 V/3 AC/50 Hz
special voltages can be supplied on request
connected load: 3.6 kW
calorific value (drying) * : max. 9.0 kW
*depending on the equipment with hopper heaters
calorific value (regenerating): max. 2.4 kW
driving power (drying, regenerating): 1.1 kW
drying temperature: max. +180 °C (356°F)
width: 900 mm (35.46 in.)
depth: 666 mm (26.2 in.)
height: 1320 mm (52.0 in.)
weight: approx. 195 kg (432.10 lbs.)s
noise: approx. 72 dB (A)
options: timer clock
..... dew point display
..... return air cooler

Return Air Cooler

water flow rate in the water mains network * : approx. 0.48 m³/h(17.05 cf/h)
(* water temperature: +6 °C) (42.8°F)
Ø pipe connection: 1/2" (0.5 in.)

SM2-605

9.3. Dimension Sheet

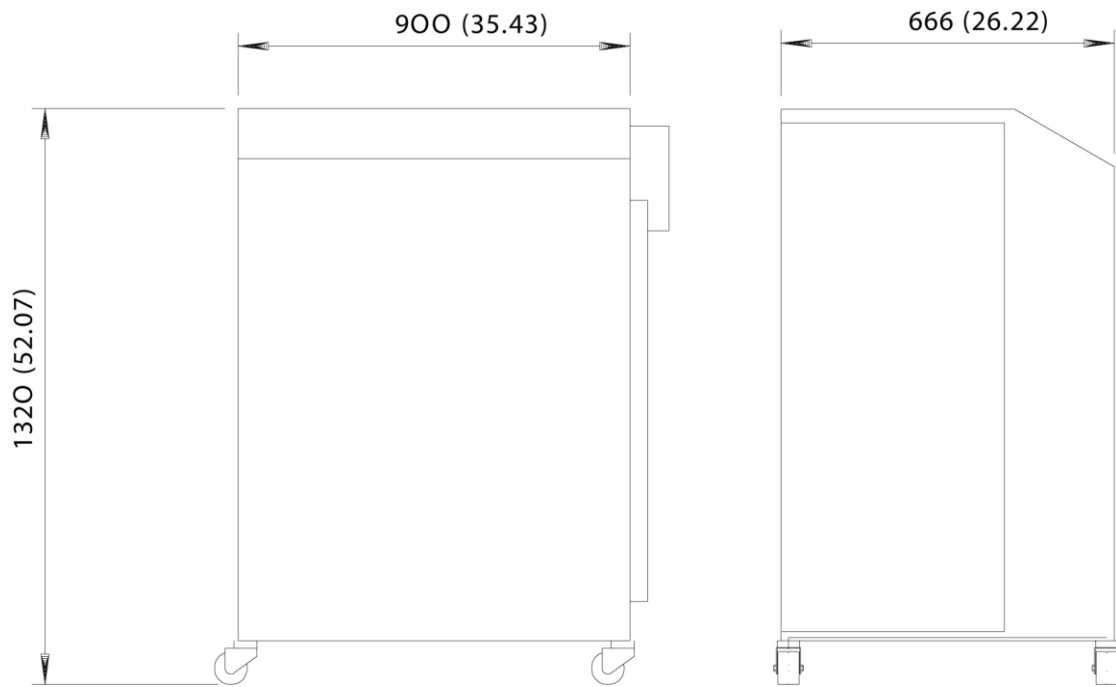

Dimensions and data without obligation. Dimensions in mm. (in.) Specifications may be subject to alterations.

10. Spare parts list



This spare parts list is intended to be used only by trained personnel.
Other persons are not permitted to modify or repair the equipment.

STT 110 / STT 160

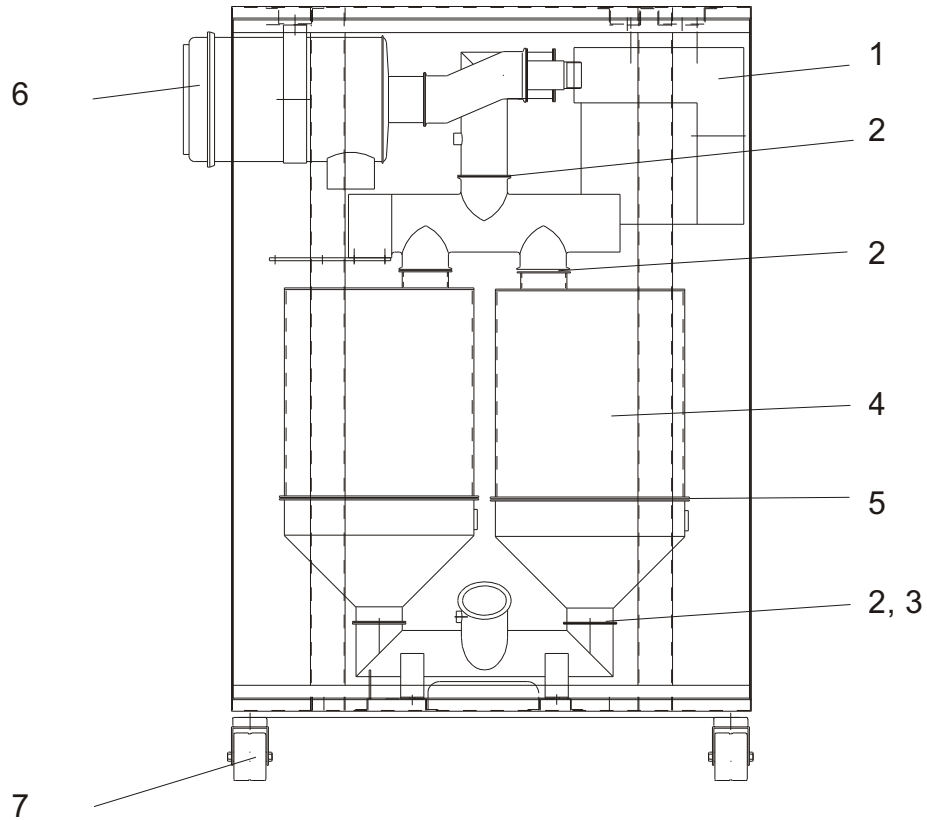

Pos.	ID-number	Description
1	85677	blower STT 110
	85367	blower STT 160
2	94233	sealing
3	85323	diffusor
4	96196	desiccant
5	23918	sealing
6	88366	filter cartridge, when operating without return air cooler
	88628	filter cartridge, when operating with return air cooler
7	85819	guide roll with fixing device
	85820	guide roll

SM2-605

Return air cooler (optional)

29786	return air cooler
83972	hose

Hopper heater

85343	radiator 1,5 kW
84512	thermal breaker
85652	temperature limiter
85338	radiator 3,0 kW
84510	thermal breaker
85652	temperature limiter
85363	radiator 6,0 kW
84509	thermal breaker
85652	temperature limiter
85651	radiator 9,0 kW
84508	thermal breaker
85652	temperature limiter
86371	Pt 100 (3 m)
89846	Pt 100 (6 m)
93303	Pt 100 (9 m)
86387	Pt 100 (12 m)
18232	air control flap
84492	thermometer
06925	flow indicator

Operating unit

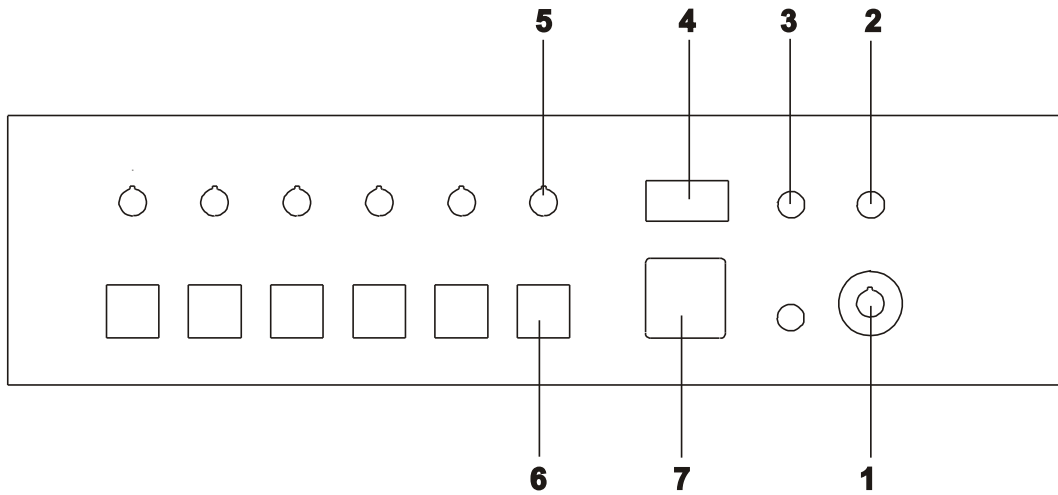

Pos.	ID-number	Description
1	82368	main switch
2	82394	LED element, green
	82393	cap
	82495	fixing adapter
3	82494	LED element, white
	82392	cap
	82495	fixing adapter
4	26207	dew point display (optional)
5	82395	selector switch actuator
	82490	contact element
6	87454	thermo regulator TT1 - TT6
7	85241	timer clock (optional)
	83646	sealing

Control unit

86376	motor
85675	radiator 2.4 kW
95819	pull-button
87440	contact element
83975	controller
85275	temperature limiter
88914	contactor
87933	power supply
83647	cut-out
88907	terminal
99815	fuse
84982	relay holder
84983	relay
83624	terminal
84512	thermal breaker STT 110
84511	thermal breaker STT 160
84159	auxiliary switch

11. Electrical manual



This electrical manual is intended to be used only by Sterling service personnel and trained personnel authorized by Sterling.

Other persons are not permitted to modify or repair the equipment.

- Connection diagram no.: _____
- Currently not available; will be delivered at a later date !

12. Accessories

- Basic setting thermo regulator
- Digital timer
- Spare parts list Drying Hoppers ST 25 - ST 6400
-
-

Basic setting thermo regulator



This information is intended to be used only by Sterling service personnel and trained personnel authorized by Sterling.

Other persons are not permitted to modify or repair the equipment.

Settings, if temperature is displayed in C°

Code				
C111	0	0	0	0
C112	2	0	0	0
C113	0	5	3	4
C114	1	0	0	1
SPL	0	0	4	0
SPH*	0	1	4	0

* with return air cooler in use: 0 1 8 0

Settings, if temperature is displayed in F°

Code				
C111	0	0	0	0
C112	2	0	3	0
C113	0	5	3	4
C114	1	0	0	1
SPL	0	1	0	4
SPH*	0	2	8	4

* with return air cooler in use: 0 3 5 6

Parameter	Parameter set 1
AL1	20.0
HYS1	1
rASd	5.0

Parameter	Parameter set 1
AL1	68.0
HYS1	1
rASd	19.0

Free Manuals Download Website

<http://myh66.com>

<http://usermanuals.us>

<http://www.somanuals.com>

<http://www.4manuals.cc>

<http://www.manual-lib.com>

<http://www.404manual.com>

<http://www.luxmanual.com>

<http://aubethermostatmanual.com>

Golf course search by state

<http://golfingnear.com>

Email search by domain

<http://emailbydomain.com>

Auto manuals search

<http://auto.somanuals.com>

TV manuals search

<http://tv.somanuals.com>