



Conveying System Mechanical Components

Part Number: 882.00379.00
Bulletin Number: SM2-605A.1
Effective: 7/25/06

Write Down Your Serial Numbers Here For Future Reference:

_____	_____
_____	_____
_____	_____

Sterling/Sterlco is committed to a continuing program of product improvement.
Specifications, appearance, and dimensions described in this manual
are subject to change without notice.

© Copyright 2006

DCN No. _____

All rights reserved.

Shipping Info

Unpacking and Inspection

You should inspect the mechanical components of your conveying system for possible shipping damage.

Thoroughly check the equipment for any damage that might have occurred in transit, such as broken or loose wiring and components, loose hardware and mounting screws, etc.

In the Event of Shipping Damage

According to the contract terms and conditions of the Carrier, the responsibility of the Shipper ends at the time and place of shipment.

Notify the transportation company's local agent if you discover damage.

Hold the damaged goods and packing material for the examining agent's inspection. **Do not return any goods before the transportation company's inspection and authorization.**

File a claim with the transportation company. Substantiate the claim by referring to the agent's report. A certified copy of our invoice is available upon request. The original Bill of Lading is attached to our original invoice. If the shipment was prepaid, write us for a receipted transportation bill.

Advise customer service regarding your wish for assistance and to obtain an RMA (return material authorization) number.

If the Shipment is Not Complete

Check the packing list as back-ordered items are noted on the packing list. You should have:

- Mechanical Components of Conveying System
- Bill of lading
- Packing list
- Operating and Installation packet
- Electrical schematic and panel layout drawings
- Component instruction manuals

Re-inspect the container and packing material to see if you missed any smaller items during unpacking.

If the Shipment is Not Correct

If the shipment is not what you ordered, **contact the shipping department immediately**. For shipments in the United States and Canada, call 1 **(800) 423-3183**; for all other countries, call our international desk at **(262) 641-8600**. Have the order number and item number available.

Hold the items until you receive shipping instructions.

Returned Material Policy

Do not return any damaged or incorrect items until you receive shipping instructions from the shipping department.

Credit Returns

Prior to the return of any material authorization must be given by the manufacturer. A RMA number will be assigned for the equipment to be returned.

Reason for requesting the return must be given.

ALL returned material purchased from the manufacturer returned is subject to 15% (\$75.00 minimum) restocking charge.

ALL returns are to be shipped prepaid.

The invoice number and date or purchase order number and date must be supplied.

No credit will be issued for material that is not within the manufacturer's warranty period and/or in new and unused condition, suitable for resale.

Warranty Returns

Prior to the return of any material, authorization must be given by the manufacturer. A RMA number will be assigned for the equipment to be returned.

Reason for requesting the return must be given.

All returns are to be shipped prepaid.

The invoice number and date or purchase order number and date must be supplied.

After inspecting the material, a replacement or credit will be given, at the manufacturer's discretion. If the item is found to be defective in materials or workmanship, and it was manufactured by our company, purchased components are covered under their specific warranty terms.

Table of Contents

CHARTS AND FIGURES.....	VIII
CHAPTER 1: SAFETY	10
1-1 How to Use This Manual.....	10
<i>Safety Symbols Used in this Manual.....</i>	<i>10</i>
1-2 Warnings and Precautions.....	11
1-3 Responsibility	12
<i>General Responsibility.....</i>	<i>12</i>
<i>Operator Responsibility</i>	<i>13</i>
<i>Maintenance Responsibility</i>	<i>14</i>
<i>Reporting a Safety Defect.....</i>	<i>14</i>
CHAPTER 2: FUNCTIONAL DESCRIPTION	15
2-1 Models Covered in This Manual	15
2-2 General Description.....	15
<i>Basic System Components.....</i>	<i>15</i>
<i>Basic System Types</i>	<i>16</i>
<i>Conveying Distance.....</i>	<i>16</i>
<i>Equipment Cycle</i>	<i>16</i>
2-3 Standard Features & Options	17
<i>SSI Series Inventory Vacuum Receivers</i>	<i>17</i>
<i>Pumps.....</i>	<i>19</i>
<i>Pumps.....</i>	<i>21</i>
<i>Blowback Pumps.....</i>	<i>23</i>
<i>Blowback Pumps.....</i>	<i>25</i>
<i>SPC Centrifugal Pumps.....</i>	<i>27</i>
<i>Atmospheric Valves.....</i>	<i>33</i>
<i>Sequence T-Valves</i>	<i>34</i>
<i>Cartridge-Style Vortex Filter Chamber</i>	<i>35</i>
<i>FC Series Bag-Style Filters.....</i>	<i>37</i>
<i>ACA Series Filter Chambers.....</i>	<i>37</i>
<i>SFC-S Series Filters.....</i>	<i>39</i>
<i>Take-Off Compartments and Pickup Tubes.....</i>	<i>40</i>
2-4 Safety Devices and Interlocks	43
CHAPTER 3: INSTALLATION.....	45
3-1 Uncrating the Equipment	45
3-2 Rigging and Placing Mechanical Components.....	45
<i>Installing the Pump Package</i>	<i>45</i>
<i>Installing the Control Panel.....</i>	<i>48</i>
<i>Installing Material/Vacuum Tubing.....</i>	<i>48</i>
<i>Installing SFC or FC Filter Chambers</i>	<i>53</i>
<i>Installing ACA Series Filter Chambers.....</i>	<i>54</i>
<i>Installing Vacuum Receivers and Inventory/Vacuum Receivers.....</i>	<i>55</i>
<i>Installing the Safety Filter.....</i>	<i>55</i>

3-3	Compressed Air Blowback Connection.....	57
3-4	Implosion Blowback Connection.....	57
	<i>Installing the Pickup Probe</i>	59
	<i>Installing the Grinder Take-off Attachment</i>	60
	<i>Installing and Adjusting the Take-off Compartment</i>	60
	<i>Adjusting Fast Take-off (FCO) Compartments</i>	61
	<i>Installing the Powder Check Adapter (Box Style; EVTO; FEVTO only)</i>	61
3-5	Compressed Air Connections.....	63
	<i>Making ACA Series Filter Chamber Compressed Air Connections</i>	63
	<i>Making Pump Compressed Air Connections</i>	63
	<i>Connecting Vacuum Receivers with Atmospheric Valve Compressed Air Lines</i> 63	
	<i>Connecting Vacuum Receivers with Sequence-T Valve Compressed Air Lines</i> .64	
	<i>Running Remote Proportioning Valve or Proportioning Vacuum Receiver</i> <i>Compressed Air Lines</i>	65
3-6	Electrical Connections.....	66
	<i>Making ACA Series Filter Chamber Electrical Connections</i>	66
	<i>Making Pump Power Drop Wiring Connections</i>	66
	<i>Making Control Panel Power Drop Wiring Connections</i>	66
	<i>Connecting the Control Panel to Vacuum Receivers</i>	67
	<i>Installing Station Bypass Switches</i>	69
	<i>Connecting the Control Panel to the Pump Package</i>	70
3-7	Initial Start-up.....	76
	<i>Making Startup Checks</i>	76
	<i>Adjusting Sight Glass Proximity Sensor Sensitivity</i>	76
	<i>Adjusting Air Pulse Duration: All Models</i>	77
	<i>ACA Series Filter Chamber Pre-Operation Checklist</i>	77
	<i>Adjusting Time Between Air Pulses on ACA Filters</i>	77
	<i>Adjusting the Number of Air Pulses</i>	77
	<i>Starting ACA Series Filter Chamber Units</i>	78
	<i>Adjusting Proximity Sensor Sensitivity</i>	78

CHAPTER 4: OPERATION..... 79

4-1	Start-up.....	79
	<i>Starting ACA Series Filter Chamber Units</i>	79
4-2	Operation Procedures	79
	<i>Vacuum Switch (VS) Operation</i>	79
	<i>High Vacuum Relief Regulator Operation</i>	80
4-3	Shut-down.....	80

CHAPTER 5: MAINTENANCE 81

5-1	Preventative Maintenance Schedule	81
5-2	Preventative Maintenance	82
	<i>Maintaining Pump Packages</i>	82
	<i>Maintaining Filter Chambers</i>	84
	<i>Inspecting ACA Series Filter Chamber Filter Bags</i>	84
	<i>Maintaining SPDB Series Vacuum Power Unit Non-Reversing Valves</i>	85
	<i>Servicing and Reassembling Lower Valves</i>	90
	<i>Maintaining Vacuum Receivers and Filter/ Receiver Combinations</i>	90
5-3	Cleaning the Collection Bin (All Models Except SFC 225 and SFC 1000).....	91
5-4	Cleaning the Filter Shroud (SFC 225 and SFC 1000 Only).....	91

5-5	Cleaning/Replacing the Filter Cartridge	92
5-6	Corrective Maintenance.....	93
	<i>Dealing with Shortened ACA Series Filter Bag Life</i>	93
CHAPTER 6: TROUBLESHOOTING		94
6-1	Introduction	94
CHAPTER 7: APPENDIX.....		102
7-1	Warranty.....	102
	<i>Warranty Specifications</i>	102
	<i>Warranty Restrictions</i>	102
	<i>Warranty Liabilities</i>	103
	<i>Customer Responsibilities</i>	103
7-2	Technical Specifications	104
7-3	Drawings and Diagrams	105
7-4	Spare Parts List.....	108
7-5	Technical Assistance.....	138
	<i>Parts Department</i>	138
	<i>Service Department</i>	138
	<i>Sales Department</i>	138
	<i>Contract Department</i>	138

Charts and Figures

1	<i>SSI Stainless Steel Inventory Vacuum Receiver Dimensions</i>	18
2	<i>Positive Displacement Pump Dimensions</i>	20
3	<i>SPD (20,30) Series Pump Dimensions</i>	22
4	<i>SPDB (5-15) Series Blowback Pump Dimensions</i>	24
5	<i>SPDB (25,30) Series Blowback Pump Dimensions</i>	26
6	<i>Centrifugal Pump Dimensions</i>	27
7	<i>Pump Specifications (Positive Displacement and Centrifugal models)</i>	28
8	<i>SSR Series Stainless Steel Vacuum Receiver Dimensions</i>	30
9	<i>SSR (6-45) Stainless Steel Vacuum Receiver Dimensions</i>	31
10	<i>SSR (85-170) Stainless Steel Vacuum Receiver Dimensions</i>	32
11	<i>Typical Atmospheric Valve</i>	33
12	<i>Typical Sequence T-Valve</i>	34
13	<i>SFC Vortex Filter Chamber Specifications and Dimensions</i>	36
14	<i>Typical ACA Series Filter Chamber</i>	38
15	<i>Compressed Air Blowback</i>	39
16	<i>ACA Series Model 51 and 53 Low Boy Filter Assembly</i>	40
17	<i>Typical Grinder Take-Off Attachment</i>	41
18	<i>Typical Take-Off Compartment</i>	41
19	<i>Typical Fast Take-Off Compartments</i>	42
20	<i>Typical Pickup Probe</i>	43
21	<i>Filter Chamber Installation, Optional Blowback Controller shown</i>	47
22	<i>Typical Multiple Line System Installation</i>	49
23	<i>Recommended Single-Line Y-Tube Installation</i>	50
24	<i>Modified Single-Line Y-Tube Installation</i>	51
25	<i>Manifold Y-Tube Installation</i>	51
26	<i>Typical Single-Line Y-Tube System Installation</i>	52
27	<i>Typical Material Check Valve</i>	53
28	<i>SFC-S Filter Installation</i>	56
29	<i>Clearing Valve Compressed Air Connections</i>	57
30	<i>Typical Powder Check Adapter</i>	62
31	<i>Solenoid Valve Location on Atmospheric Valve & Compressed Air Connections</i>	64
32	<i>Solenoid Valve Location on Sequence – T Valve & Compressed Air Connections</i>	65
33	<i>Volume-Fill, Time-Fill, Vacuum Receiver Wiring Connections (115 VAC Control Unit)</i>	68
34	<i>Volume-Fill, Time-Fill, Vacuum Receiver Wiring Connections (24 VDC Control Unit)</i>	69
35	<i>Recommended Field-Installed Optional Station Bypass Switch</i>	70
36	<i>Typical SPD Series Junction Box Wiring Diagram</i>	71
37	<i>Typical SPD Series Junction Box with Fused Disconnect Wiring Diagram</i>	72
38	<i>Typical SPDB (5-15) Series Junction Box Wiring Diagram</i>	73
39	<i>Typical SPDB (25,30) Series Junction Box Wiring Diagram</i>	74

40	Typical SPDB (25,30) Series Junction Box with Fused Disconnect Wiring Diagram	75
41	ACA Series Model 50 Blowback DIP Switch Settings	77
42	Non-Reversing Valve Cycle of Operation (SPDB Pumps)	105
43	Equipment Cycles	106
44	Typical SSR Series Vacuum Receiver Exploded View	108
45	SSR Series Vacuum Receiver Parts List	109
46	Typical SSR Series Vacuum Receiver Exploded View	110
47	SSR Series Vacuum Receiver Parts List (Pre-May 2003)	111
48	Typical SSR06-45 Series Vacuum Receiver Exploded View (Post-May 2003)	112
49	SSR06-45 Series Vacuum Receiver Parts List (Post-May 2003)	113
50	Typical SSR Series Vacuum Receiver Exploded View	114
51	SSR 85/170 Series Vacuum Receiver Parts List	115
52	Typical SSI Series Inventory Vacuum Receiver Exploded View	116
53	SSI Series Inventory Vacuum Receiver Parts List	117
54	SFC Filter Chamber Spare Parts List, Models SFC 225 & SFC 1000	118
55	FC Filter Chamber Spare Parts List, Models FC15, FC30, & FC35	118
56	Vacuum Power Units; 5 to 15hp (3.73-11.19kW) Models Exploded View	119
57	Vacuum Power Units; 5 to 15hp (3.73-11.19kW) Models Spare Parts List	120
58	Vacuum Power Units 25 to 30hp (18.65-22.38kW) Models Exploded View	121
59	Vacuum Power Units 25 to 30hp (18.65-22.38kW) Models Spare Parts List	122
60	SFC-S Filter	123
61	SFC-S Spare Parts List	124
62	SPD Spare Parts Drawing	125
63	SPD Spare Parts List	126-28
64	SPD Reversing Valve Option Spare Parts Drawing	129
65	SPD Reversing Valve Option Spare Parts List	130
66	SPDB Spare Parts Drawing	131
67	SPDB Spare Parts List	132-35
68	SPC Spare Parts Drawing	136
69	Centrifugal Vacuum Pump Spare Parts List	136

Chapter 1: Safety

1-1 How to Use This Manual

Use this manual as a guide and reference for installing, operating, and maintaining the mechanical components of your conveying system. The purpose is to assist you in applying efficient, proven techniques that enhance equipment productivity.

This manual covers only light corrective maintenance. No other maintenance should be undertaken without first contacting a service engineer.

The Functional Description section outlines models covered, standard features, and safety features. Additional sections within the manual provide instructions for installation, pre-operational procedures, operation, preventive maintenance, and corrective maintenance.

The Installation chapter includes required data for receiving, unpacking, inspecting, and setup of the mechanical components of your conveying system. We can also provide the assistance of a factory-trained technician to help train your operator(s) for a nominal charge. This section includes instructions, checks, and adjustments that should be followed before commencing with operation of the conveying system. These instructions are intended to supplement standard shop procedures performed at shift, daily, and weekly intervals.

The Operation chapter includes a description of electrical and mechanical controls, in addition to information for operating the conveying system safely and efficiently.

The Maintenance chapter is intended to serve as a source of detailed assembly and disassembly instructions for those areas of the equipment requiring service. Preventive maintenance sections are included to ensure that the mechanical components of your conveying system provide excellent, long service.

The Troubleshooting chapter serves as a guide for identification of most common problems. Potential problems are listed, along with possible causes and related solutions.

The Appendix contains technical specifications, drawings, schematics, parts lists, and available options. A spare parts list with part numbers specific to your machine is provided with your shipping paperwork package. Refer to this section for a listing of spare parts for purchase. Have your serial number and model number ready when ordering.

Safety Symbols Used in this Manual







The following safety alert symbols are used to alert you to potential personal injury hazards. Obey all safety messages that follow these symbols to avoid possible injury or death.

DANGER! *DANGER indicates an imminently hazardous situation that, if not avoided, will result in death or serious injury.*

WARNING! *WARNING indicates a potentially hazardous situation or practice that, if not avoided, could result in death or serious injury.*

Caution! *CAUTION indicates a potentially hazardous situation or practice that, if not avoided, may result in minor or moderate injury or in property damage.*

Conveying System Safety Tags

Tag	Description	Tag	Description
	Read Operation & Installation Manual		High Voltage Inside Enclosure
	Protected Earth Ground		Earth Ground
	Lifting Point		Spraying Hazard

1-2 Warnings and Precautions

Our equipment is designed to provide safe and reliable operation when installed and operated within design specifications, following national and local safety codes. This may include, but is not limited to OSHA, NEC, CSA, SPI, and any other local, national and international regulations.

To avoid possible personal injury or equipment damage when installing, operating, or maintaining this equipment, use good judgment and follow these safe practices:

- Read and follow these operation and installation instructions when installing, operating, and maintaining this equipment. If these instructions become damaged or unreadable, additional copies are available from the manufacturer.
- Follow all **SAFETY CODES**.
- Wear **SAFETY GLASSES** and **WORK GLOVES**.
- Work only with approved tools and devices.
- Disconnect and/or lock out power before servicing or maintaining the equipment.
- Use care when **LOADING, UNLOADING, RIGGING, or MOVING** this equipment.
- Operate this equipment within design specifications.
- OPEN, TAG, and LOCK ALL DISCONNECTS** before working on equipment. You should remove the fuses and carry them with you.
- Make sure the equipment and components are properly **GROUNDING** before you switch on power.
- Use extreme caution when working with your conveying system. **HIGH VACUUM** can be dangerous. Keep body parts, tools, clothing, and debris away from vacuum inlets.
- When welding or brazing in or around this equipment, make sure **VENTILATION** is **ADEQUATE**. **PROTECT** adjacent materials from flame or sparks by shielding with sheet metal. An approved **FIRE EXTINGUISHER** should be nearby and ready for use if needed.

- ☑ Do not restore power until you remove all tools, test equipment, etc., and the equipment and related components are fully reassembled.
- ☑ Only **PROPERLY TRAINED** personnel familiar with the information in this manual should work on this equipment.

We have long recognized the importance of safety and have designed and manufactured our equipment with operator safety as a prime consideration. We expect you, as a user, to abide by the foregoing recommendations in order to make operator safety a reality.

1-3 Responsibility

These machines are constructed for maximum operator safety when used under standard operating conditions and when recommended instructions are followed in the maintenance and operation of the machine.

All personnel engaged in the use of the machines should become familiar with their operation as described in this manual.

Proper operation of the machine promotes safety for the operator and all workers in its vicinity.

Each individual must take responsibility for observing the prescribed safety rules as outlined. All warning and danger signs must be observed and obeyed. All actual or potential danger areas must be reported to your immediate supervisor.

General Responsibility

No matter who you are, safety is important. Owners, operators and maintenance personnel must realize that every day, safety is a vital part of their jobs.

If your main concern is loss of productivity, remember that production is always affected in a negative way following an accident. The following are some of the ways that accidents can affect your production:

- Loss of a skilled operator (temporarily or permanently)
- Breakdown of shop morale
- Costly damage to equipment
- Downtime

An effective safety program is responsible and economically sound.

Organize a safety committee or group, and hold regular meetings. Promote this group from the management level. Through this group, the safety program can be continually reviewed, maintained, and improved. Keep minutes or a record of the meetings.

Hold daily equipment inspections in addition to regular maintenance checks. You will keep your equipment safe for production and exhibit your commitment to safety.

Please read and use this manual as a guide to equipment safety. This manual contains safety warnings throughout, specific to each function and point of operation.

Operator Responsibility

The operator's responsibility does not end with efficient production. The operator usually has the most daily contact with the equipment and intimately knows its capabilities and limitations.

Plant and personnel safety is sometimes forgotten in the desire to meet incentive rates, or through a casual attitude toward machinery formed over a period of months or years. Your employer probably has established a set of safety rules in your workplace. Those rules, this manual, or any other safety information will not keep you from being injured while operating your equipment.

Learn and always use safe operation. Cooperate with co-workers to promote safe practices. Immediately report any potentially dangerous situation to your supervisor or appropriate person.

REMEMBER:

- **NEVER** place your hands or any part of your body in any dangerous location.
- **NEVER** operate, service, or adjust the conveying system without appropriate training and first reading and understanding this manual.
- **NEVER** try to pull material out of the conveying system with your hands while it is running!
- Before you start the conveying system, check the following:
 - Remove all tools from the conveying system.
 - Be sure no objects (tools, nuts, bolts, clamps, bars) are lying in the area.
- If your conveying system has been inoperative or unattended, check all settings before starting the unit.
- At the beginning of your shift and after breaks, verify that the controls and other auxiliary equipment are functioning properly.
- Keep all safety guards in place and in good repair. **NEVER** attempt to bypass, modify, or remove safety guards. Such alteration is not only unsafe, but will void the warranty on your equipment.
- When changing control settings to perform a different mode of operation, be sure selector switches are correctly positioned. Locking selector switches should only be adjusted by authorized personnel and the keys removed after setting.
- Report the following occurrences **IMMEDIATELY**:
 - unsafe operation or condition
 - unusual conveying system action
 - leakage
 - improper maintenance
 - **NEVER** stand or sit where you could slip or stumble into the conveying system while working on it.

- **DO NOT** wear loose clothing or jewelry, which can be caught while working on the conveying system. In addition, cover or tie back long hair.
- Clean the conveying system and surrounding area **DAILY**, and inspect the machine for loose, missing or broken parts.
- Shut off power to the conveying system when it is not in use. Turn the switch to the **OFF** position, or unplug it from the power source.

Maintenance Responsibility

Proper maintenance is essential to safety. If you are a maintenance worker, you must make safety a priority to effectively repair and maintain equipment.

Before removing, adjusting, or replacing parts on a machine, remember to turn off all electric supplies and all accessory equipment at the machine, and disconnect and lockout electrical and pneumatic power. Attach warning tags to the disconnect switch and air shutoff valve.

When you need to perform maintenance or repair work on a conveying system above floor level, use a solid platform or a hydraulic elevator. If there is a permanently installed catwalk on your conveying system, use it. The work platform should have secure footing and a place for tools and parts. **DO NOT** climb on the conveying system, machines, or work from ladders.

If you need to repair a large component, use appropriate handling equipment. Before you use handling equipment (portable “A” frames, electric boom trucks, fork trucks, overhead cranes) be sure the load does not exceed the capacity of the handling equipment or cause it to become unstable.

Carefully test the condition of lifting cables, chains, ropes, slings, and hooks before using them to lift a load.

Be sure that all non-current carrying parts are correctly connected to earth ground with an electrical conductor that complies with current codes. Install in accordance with national and local codes.

When you have completed the repair or maintenance procedure, check your work and remove your tools, rigging, and handling equipment.

Do not restore power to the conveying system until all persons are clear of the area. **DO NOT** start and run the conveying system until you are sure all parts are functioning correctly.

BEFORE you turn the conveying system over to the operator for production, verify all enclosure panels, guards and safety devices are in place and functioning properly.

Reporting a Safety Defect

If you believe that your equipment has a defect that could cause injury, you should immediately discontinue its use and inform the manufacturer.

The principle factors that can result in injury are failure to follow proper operating procedures (i.e. lockout/tagout), or failure to maintain a clean and safe working environment.

Chapter 2: Functional Description

2-1 Models Covered in This Manual

This manual provides operation, installation, and maintenance instructions for the mechanical components of the conveying system. Model numbers are listed on the serial tag. Make sure you know the model and serial number of your equipment before contacting the manufacturer for parts or service.

Our mechanical components are designed to create vacuum for conveying pelletized, granular, or powder material in a central material handling system. A typical use is as an in-plant distribution system for plastic processing plants. Conveying system mechanical components are sized to meet the specific requirements stated by the Customer at the time of purchase.

2-2 General Description

Our central vacuum systems are as varied as the applications that they service. Tubing and equipment furnished in a specially designed system is intended to convey the material(s) specified at the time of purchase at specific rates and distances.

We can advise you on your system capabilities based on system makeup, distance, material, and desired conveying rates.

Pressure drops in the overall system directly affect system capacity, such as number of material line bends, footage of pipe, Y-tubes, T-tubes, etc.

The less distance, flexible hose, and bends you use on material lines, the better. Keep material lines as straight as possible.

Note: Vacuum leaks occurring anywhere in your system reduce capacity.

Basic System Components

A typical conveying system contains the following components:

- Vacuum receiver(s)
- Vacuum pump
- Filter chamber
- Sequence or atmospheric valves
- Controller
- Take-off compartments
- Pickup tubes/wands
- Vacuum and material tubing

Combinations of these components will help you build your system for the application you need.

Basic System Types

Time-Fill Systems

A *time-fill system* conveys material to an on-line vacuum receiver for a pre-set time period. When this interval elapses, the controller conveys material to the next on-line vacuum receiver.

Volume-Fill Systems

A *volume-fill system* conveys material to an on-line vacuum receiver until the material level activates the proximity switch in the vacuum receiver, or a preset time elapses. When either of these conditions occur, the controller conveys material to the next on-line vacuum receiver.

Conveying Distance

Vacuum hoppers and Low Head Separators are installed over the material delivery point.

The Vacuum Power Unit and material pick-up device, however, can be installed some distance from the delivery point. This distance is dependent upon the power unit chosen and the total equivalent feet required to convey the material.

The manufacturer's Engineering Department can advise you on your system's capabilities given the system make-up, distance, material and desired conveying rates.

Equipment Cycle

Our bulk material conveying systems are used for automatic pneumatic handling of most free-flowing, dry, pelletized, powder granular materials. Add a Low Head Separator, and fine powders can be conveyed. Most systems are custom designed using standard components.

A positive displacement blower draws air through the non-reversing valves on the Vacuum Power Unit. (See Figure 42 on page 105).

The vacuum is drawn through a filter chamber to prevent material from reaching the blower.

Signals from the programmable controller shift Sequence-"T" Valves to direct the vacuum through the station being filled to a material pick-up device.

Material is sucked into a pick-up device and through the material tubing to the vacuum hopper or Low Head Separator, mounted or suspended over a storage bin or processing equipment.

When the vacuum hopper is filled or the convey cycle times out, the convey cycle ends. The Vacuum Power Unit immediately shifts into blowback, dumping the material in the vacuum hopper.

The blowback cycle backflushes air through the vacuum tubing to clean the filter chamber.

The blowback feature cleans the filter chamber after each loading cycle and speeds emptying of the vacuum hopper. This operation is continuous and automatic. (See Figure 43 on page 106).

The programmable controller automatically shifts the appropriate sequence "T"-valves and starts the loading cycle at the next station in the cycle.

The cycle continues until the programmable controller senses, through level sensors at each station, that all stations are filled.

Material characteristics determine the type of equipment needed to properly convey the material.

See Figures 22 and 26 on pages 49 and 52 for typical system configurations.

2-3 Standard Features & Options

SSI Series Inventory Vacuum Receivers

Models: SSI03, SSI06, SSI11

- Brushed stainless steel construction, with stainless steel product contact surfaces.
- Pyrex™ sight glass.
- Receiver capacities of 0.1, 0.2, and 0.4 cu. ft. (2.8, 5.6, and 11.3 liters).
- Ten (10) -mesh stainless steel pellet deflector screen.
- Designed for minimum inventory on molding machine.
- Four-inch (101.6 mm) -sq. flange on 0.1 cu. ft. (2.8 liter) model.
- Seven-inch (177.8 mm) -sq. flange on 0.2 and 0.4 cu. ft. (5.6 and 11.3 liter) models.
- Side inlet/outlet design.
- Removable inlets and outlets, up to 2" O.D. on 0.2 and 0.4 cu. ft (5.6 and 11.3 liter) models; material inlet is check valve-ready.
- Check valve for single-line Y applications.
- Adjustable proximity-type material level sensor (mounted on sight glass): 24 VDC or 115 VAC.

Figure 1: SSI Series Stainless Steel Inventory Vacuum Receiver Dimensions

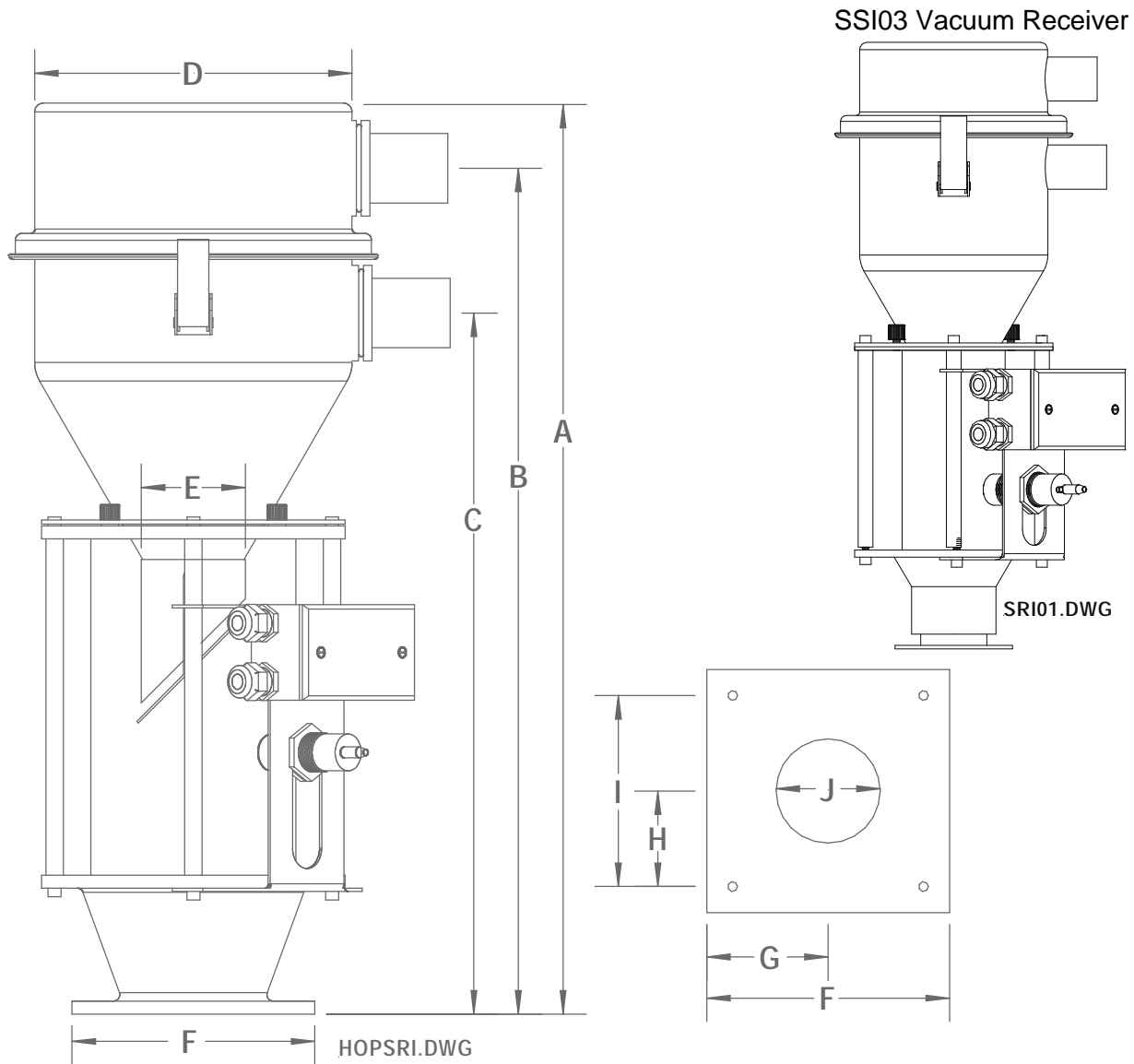

Model	Unit size cu. ft.	Dimensions in inches									
		A	B	C	D	E	F -sq.	G -sq.	H -sq.	I -sq. ①	J
SSI03	0.1	21 1/4"	20"	16 5/8"	6 3/8"	1 3/4"	4"	2"	1 1/4"	2 1/2"	2"
SSI06	0.2	25 5/8"	23 3/4"	19 1/2"	9 1/8"	3"	7"	3 1/2"	2 3/4"	5 1/2"	3"
SSI11	0.4	31 1/2"	29 5/8"	25 1/2"	9 1/8"	3"	7"	3 1/2"	2 3/4"	5 1/2"	3"

Model	Unit size liters	Dimensions in cm									
		A	B	C	D	E	F -sq.	G -sq.	H -sq.	I -sq. ①	J
SSI03	2.8	54.0 cm	50.8 cm	42.2 cm	16.2 cm	4.4 cm	10.2 cm	5.1 cm	3.2 cm	6.4 cm	5.1 cm
SSI06	5.6	65.1 cm	60.3 cm	49.5 cm	23.2 cm	7.6 cm	17.8 cm	8.9 cm	6.9 cm	13.9 cm	7.6 cm
SSI11	11.3	80.0 cm	75.2 cm	64.8 cm	23.2 cm	7.6 cm	17.8 cm	8.9 cm	6.9 cm	13.9 cm	7.6 cm

① 9 9/32"/0.28125" (7.14 mm) -diameter holes in four (4) places, equally spaced.

Pumps

SPD Series Models: SPD5, SPD7.5, SPD10, SPD15

- Support base.
- Positive displacement blower.
- 3-phase high efficiency TEFC electric motor.
- 5, 7.5, 10, or 15 horsepower (3.75, 5.63, 7.5, or 11.25 kW).
- Standard voltage is 230-460/3/60. 380-415/3/50 and 575/3/60 are optional.
- Adjustable motor base.
- Compressed air-operated mechanical high-vacuum relief valve.
- Vacuum gauge.
- Vacuum switch for high vacuum protection.
- Junction box with motor starter, including overload protection.
- Discharge silencer.

Options

- Fused disconnect in the junction box.
- Distributed I/O capability.
- Sound enclosure.
- Premium-efficiency motors.
- Re-sheave for elevation.
- 24VDC or 120 AC controls.

Figure 2: Positive Displacement Pump Dimensions

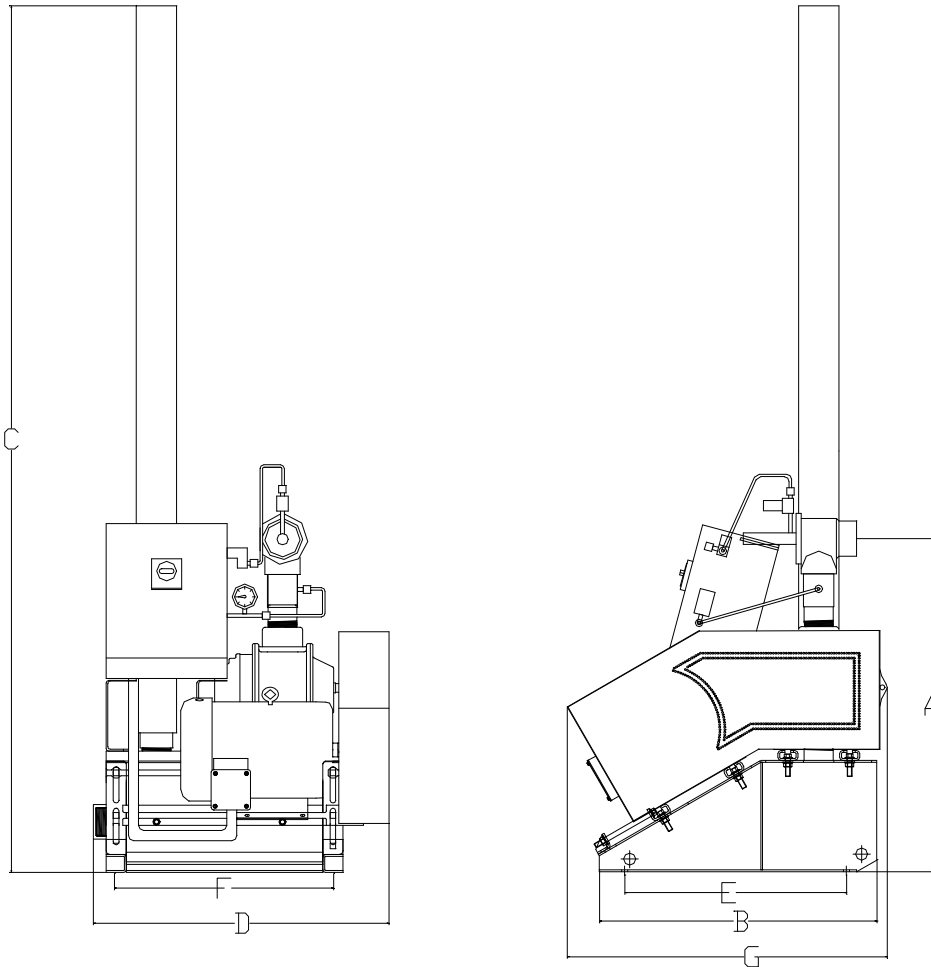

Model	Unit size hp	Dimensions (inches)						
		A	B	C	D	E	F	G
SPD 5	5	33	27.5	85.82	29	22	21.75	31.75
SPD 7.5	7.5							
SPD 10	10							
SPD 15	15							

Model	Unit size kW	Dimensions (cm)						
		A	B	C	D	E	F	G
SPD 5	3.75	84	70	218	74	56	55	81
SPD 7.5	5.6							
SPD 10	7.5							
SPD 15	11.25							

Pumps

SPD Series Models: SPD20, SPD30

- Support base.
- Positive displacement blower.
- 3-phase high efficiency TEFC electric motor.
- 20 or 30 horsepower (15 or 22.5 kW).
- Standard voltage is 230-460/3/60. 380-415/3/50 and 575/3/60 are optional.
- Adjustable motor base.
- Compressed air-operated mechanical high-vacuum relief valve.
- Vacuum gauge.
- Vacuum switch for high vacuum protection.
- Junction box with motor starter, including overload protection.
- Discharge silencer.

Options

- Fused disconnect in the junction box.
- Distributed I/O capability.
- Sound enclosure.
- Premium-efficiency motors.
- Re-sheave for elevation.
- 24VDC or 120 AC controls.

Figure 3: SPD 20, 30 Series Pump Dimensions

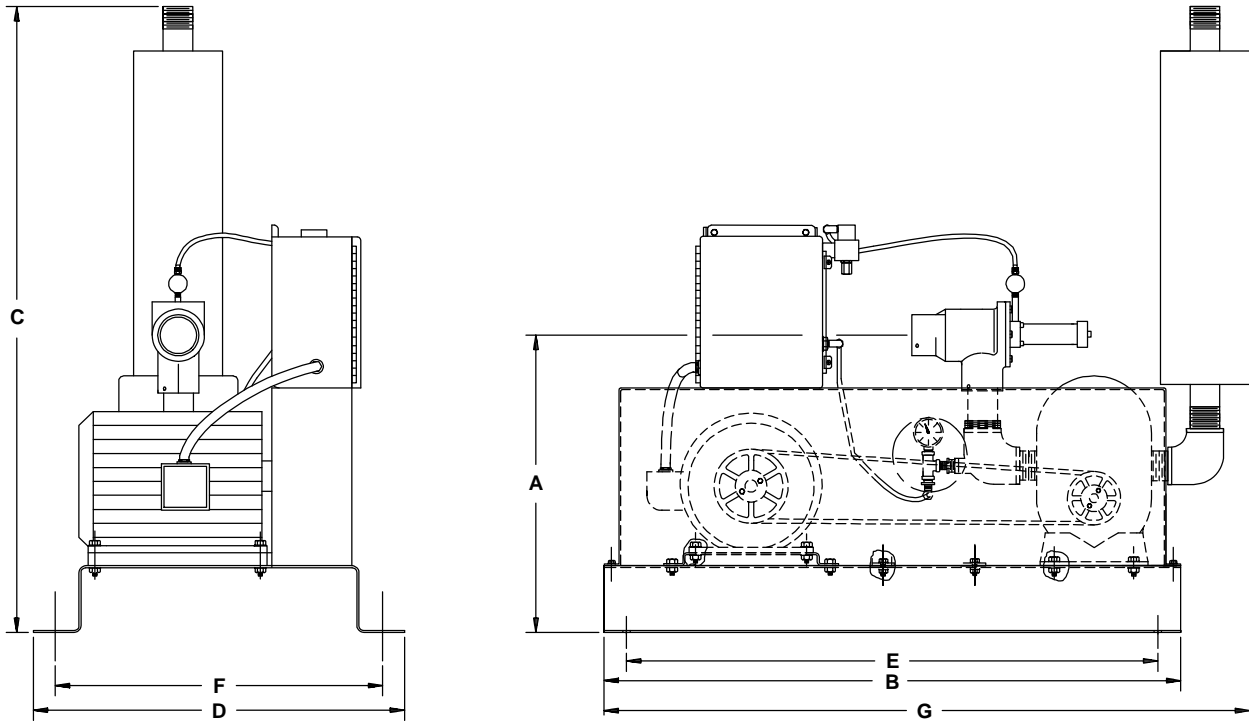

Model	Unit size	Dimensions (inches)						
	hp	A	B	C	D	E	F	G
SPD 20	20	32	56	65	32.5	53	31	60
SPD 30	30	38	50	85	37.25	48.25	35.75	69.3

Model	Unit size	Dimensions (cm)						
	KW	A	B	C	D	E	F	G
SPD 20	15.00	81	142	178	82	134	79	167
SPD 30	22.38	97	127	216	95	123	91	176

Blowback Pumps

SPDB Series Models: SPDB5, SPDB7.5, SPDB10, SPDB15

- Compressed air-operated blowback and vacuum valves with high-vacuum relief.
- Mechanical high-vacuum relief valve.
- Support base.
- Positive displacement blower.
- Three (3) -phase high efficiency TEFC electric motor.
- 5, 7.5, 10, or 15 horsepower (3.75, 5.63, 7.5, or 11.25 kW)
- Standard 230-460/3/60. 380-415/3/50. 575/3/60 is optional.
- Adjustable motor base.
- Vacuum gauge.
- Vacuum switch for high vacuum protection.
- Junction box with motor starter, including overload protection.
- Discharge silencer.

Options

- Fused disconnect in the junction box.
- Distributed I/O capability.
- Sound enclosure.
- Efficiency motors available.
- Re-sheave for elevation.
- 24VDC or 120VAC controls.

Figure 4: SPDB 5-15 Series Blowback Pump Dimensions

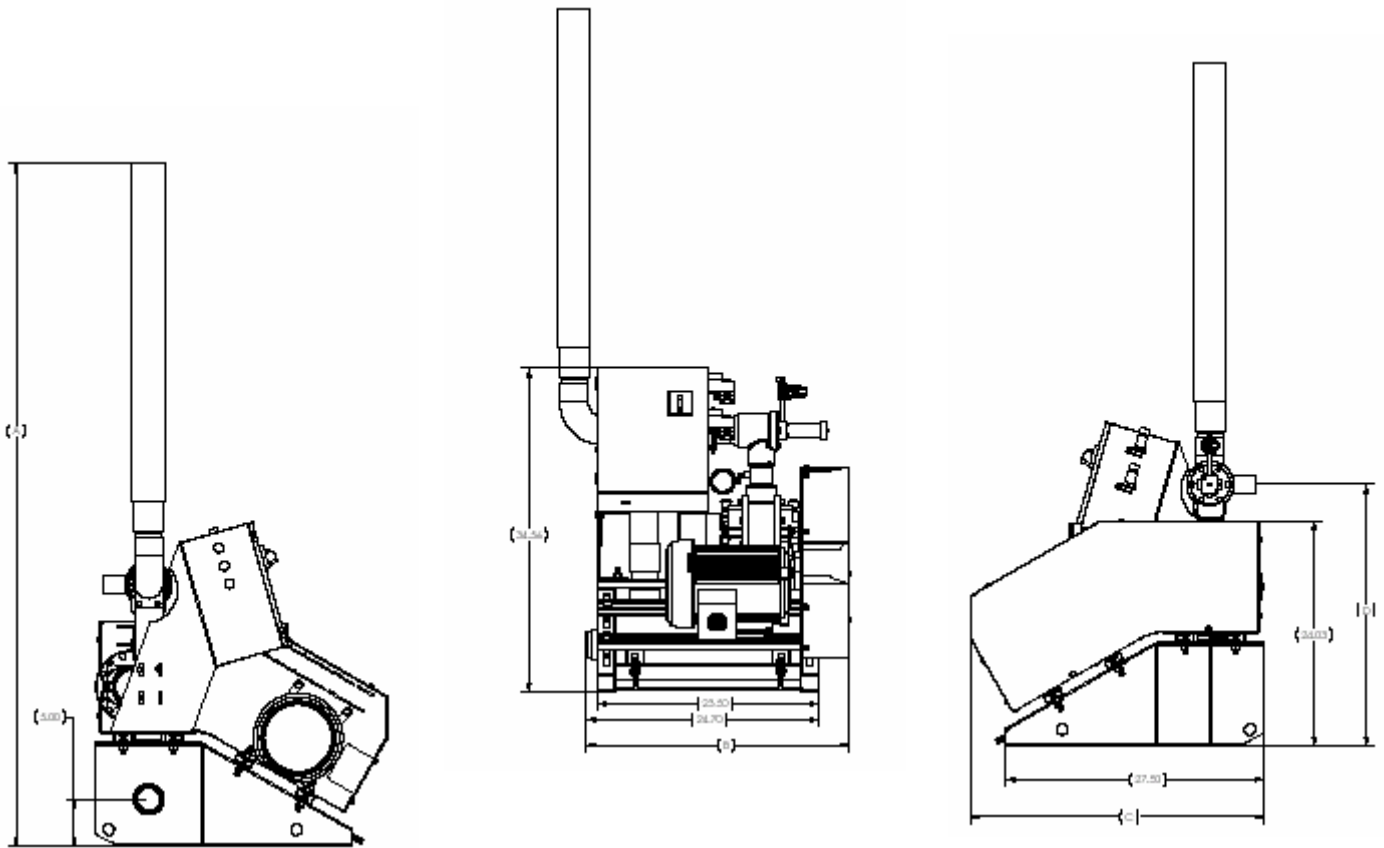

Model	Unit size hp	Dimensions (inches)			
		A	B	C	D
SPDB 5	5	64.71	64.84	64.84	64.84
SPDB 7.5	7.5	28.22	29.34	29.34	29.34
SPDB 10	10	31.10	31.10	31.10	31.75
SPDB 15	15	27.84	30.93	30.93	30.93

Model	Unit size kW	Dimensions (cm)			
		A	B	C	D
SPDB 5	3.75	164.36	164.69	164.69	164.69
SPDB 7.5	5.6	71.68	74.52	74.52	74.52
SPDB 10	7.5	78.99	78.99	78.99	80.65
SPDB 15	11.25	70.71	78.56	78.56	78.56

Blowback Pumps

SPDB Series Models: SPDB 25, SPDB 30

- Compressed air-operated blowback and vacuum valves with high-vacuum relief.
- Mechanical high-vacuum relief valve.
- Support base.
- Positive displacement blower.
- Three (3) -phase high efficiency TEFC electric motor.
- 25 or 30 horsepower (18.75 or 22.5 kW)
- Standard 230-460/3/60. 380-415/3/50. 575/3/60 is optional.
- Adjustable motor base.
- Vacuum gauge.
- Vacuum switch for high vacuum protection.
- Junction box with motor starter, including overload protection.
- Discharge silencer.

Options

- Fused disconnect in the junction box.
- Distributed I/O capability.
- Sound enclosure.
- Efficiency motors available.
- Re-sheave for elevation.
- 24VDC or 120VAC controls.

Figure 5: SPDB 25, 30 Series Blowback Pump Dimensions

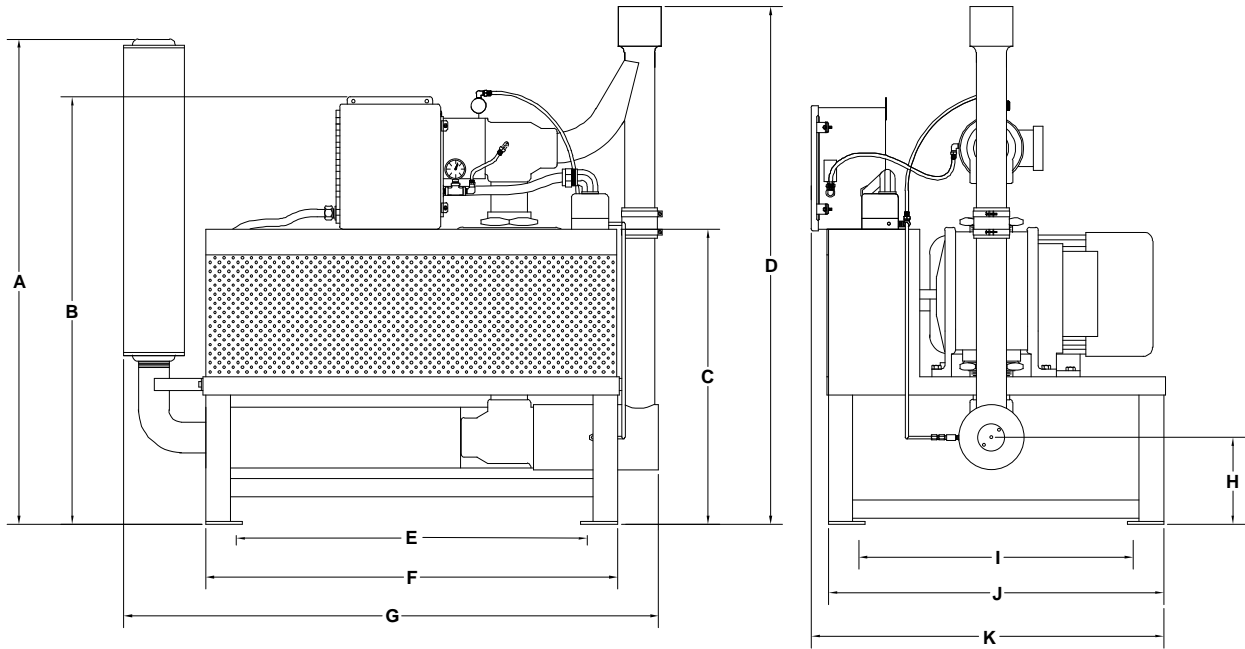

Model	Unit size hp	Dimensions (inches)										
		A	B	C	D	E	F	G	H	I	J	K
SPDB 25	25	80	60	39	74	42.5	46	65	9	31.5	35	32
SPDB 30	30	80	60	39	74	42.5	46	65	9	31.5	35	32

Model	Unit size kW	Dimensions (cm)										
		A	B	C	D	E	F	G	H	I	J	K
SPDB 25	18.75	203	152	101	188	108	117	166	23	80	89	81
SPDB 30	22.50	203	152	101	188	108	117	166	23	80	89	81

SPC Centrifugal Pumps

Models: 3.5, 6.5 & 11 Hp

- Centrifugal blower.
- Cartridge filter.
- Vent valve
- Junction box with starter mounted on unit.

Figure 6: Centrifugal Pump Dimensions

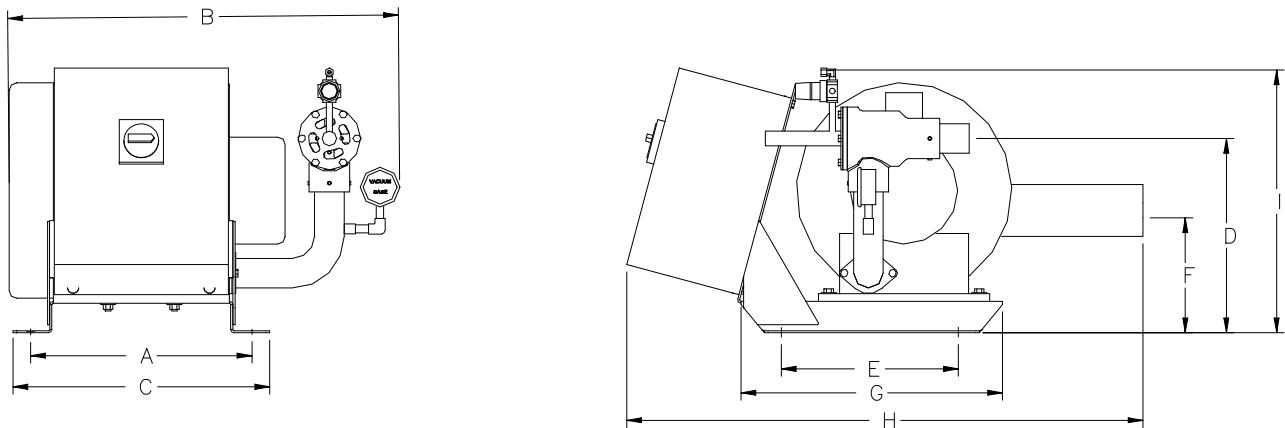

Model	Unit size Hp*	Dimensions (inches)								
		A	B	C	D	E	F	G	H	I
SPC 3.5	3.5	15	26.25	17.4	13	12	8.75	17.75	35	18
SPC 6.5	5		24.5		13		7.5		31	17.75
SPC 11.5	11.5		31.5		14.8		8.6		35.5	19

Model	Unit size kW	Dimensions (cm)								
		A	B	C	D	E	F	G	H	I
SPC 3.5	2.63	38	67	44	33	30	22	45	89	46
SPC 6.5	4.84		62		33		19		79	45
SPC 11.0	8.58		80		37		21		90	48

*At 460/3/60

Figure 7: SPD, SPDB, and SPC Pump Specifications (Positive Displacement and Centrifugal pumps)

Model	hp	Amp draw, full-load amps			Air flow ①	Line size inches		Ship weight lbs.
		230 V	460 V	575 V	cfm			
<i>Pumps — Positive Displacement Models</i>						<i>Vacuum</i>	<i>Material</i>	
SPD 5	5	13.4	6.7	5.4	120	2.0"	2.0"	385
SPD 7.5	7.5	20.6	10.3	8.2	155	2.5"	2.5"	400
SPD 10	10	28.4	14.2	11.4	200	2.5"	2.5"	400
SPD 10	10	29.2	14.6	11.7	300	3.0"	3.0"	400
SPD 15	15	38.4	19.2	15.3	300	3.0"	3.0"	420
SPD 15	15	39.2	19.6	15.7	360	3.5"	3.5"	420
SPD 20	20	49.6	24.8	19.8	475	4.0"	4.0"	1,600
SPD 30	30	76.3	38.1	30.4	665	5.0"	5.0"	1,700
SPDB 5	5	13.4	6.7	5.4	120	2.0"	2.0"	385
SPDB 7.5	7.5	20.6	10.3	8.2	155	2.5"	2.5"	400
SPDB 10	10	28.4	14.2	11.4	200	2.5"	2.5"	400
SPDB 10	10	29.2	14.6	11.7	300	3.0"	3.0"	400
SPDB 15	15	38.4	19.2	15.3	300	3.0"	3.0"	420
SPDB 15	15	39.2	19.6	15.7	360	3.5"	3.5"	420
SPDB 25	25	49.6	24.8	19.8	570	4.5" Sch. 10 pipe	4.5" Sch. 10 pipe	1,600
SPDB 30	30	76.3	38.1	30.4	711	5" Sch. 10 pipe	5" Sch. 10 pipe	1,700
<i>Pumps — Centrifugal Models</i>						<i>Vacuum</i>	<i>Material</i>	
SPC 3.5	3.5	9.1	4.6	3.0	106	2.0"	1.5"	175
SPC 6.5	5	12.9	6.5	4.3	152	2.0"	2.0"	300
SPC 11.5	11.5	32.5	16.2	10.6	225	2.5"	2.5"	350

Model	kW	Amp draw, full-load amps			Air flow ①	Line size mm	Ship weight Kg
		230 V	460 V	575 V	cmh		
<i>Pumps — Positive Displacement Models</i>							
SPD 5	3.75	13.4	6.7	5.4	204	50 mm	175
SPD 7.5	5.6	20.6	10.3	8.2	155	63 mm	181
SPD 10	7.5	28.4	14.2	11.4	339	63.5 mm	181
SPD 10	7.5	29.2	14.6	11.7	381	76 mm	181
SPD 15	11.2	38.4	19.2	15.3	508	76 mm	190
SPD 15	11.2	39.2	19.6	15.7	610	89 mm	190
SPD 20	15.00	49.6	24.8	19.8	805	101.6 mm	727
SPD 30	22.4	76.3	38.1	30.4	1,127	127 mm	789
SPDB 5	3.75	13.4	6.7	5.4	204	50 mm	175
SPDB 7.5	5.6	20.6	10.3	8.2	155	63 mm	181
SPDB 10	7.5	28.4	14.2	11.4	339	63.5 mm	181
SPDB 10	7.5	29.2	14.6	11.7	381	76 mm	181
SPDB 15	11.2	38.4	19.2	15.3	508	76 mm	190
SPDB 15	11.2	39.2	19.6	15.7	610	89 mm	190
SPDB 25	18.7	49.6	24.8	19.8	968	4" Sch. 10 pipe	727
SPDB 30	22.4	76.2	38.1	30.4	1,208	5" Sch. 10 pipe	789
<i>Pumps — Centrifugal Models</i>							
SPC 3.5	2.63	9.1	4.6	3.0	180	38 mm	80
SPC 6.5	4.84	12.9	6.5	4.3	258	50 mm	136
SPC 11.5	8.58	32.5	16.2	10.6	302	63 mm	159

① Air flow measured in cubic feet per minute (cfm) and cubic meters per hour (cmh).

Note: Rated performance is at standard atmosphere and sea level conditions. High elevation affects system performance.

SSR Vacuum Receivers

Models: SSR03, SSR06, SSR11, SSR23, SSR45, SSR85, SSR170

- Receiver capacities of 0.1, 0.2, 0.4, 0.8, 1.6, 3.0, and 6.0 cu. ft. (2.8, 5.6, 11.3, 22.6, 45.3, 84.9, and 169.9 liters).
- Brushed stainless steel construction, with stainless steel product contact surfaces.
- Material demand/level sensor with Normally Open (std.) or Normally Closed (version available) contacts.
- Perforated stainless steel pellet deflectors (SSR85/170 Models).
- Ten (10)-mesh stainless steel pellet deflector screen (SSR06–45 models only).
- Removable side inlets and outlets – up to 3” O.D. (except on 0.1 cu. ft. [2.8 liter] models).
- Internal check valve on material inlets (up to 3” line size) – Not on SSR06 models.

Options

- Volume fill sensor.
- Optiview sensor.
- Spun aluminum riser.
- Filters (polyester and nylon).
- Throat gaskets – high temp & food grade.
- Consult assembly drawings for optional materials.

Note: *SSR85/170 models can be vented or non-vented or equipped with a silo mount riser with an access door.*

Figure 8: SSR Series Stainless Steel Vacuum Receiver Dimensions

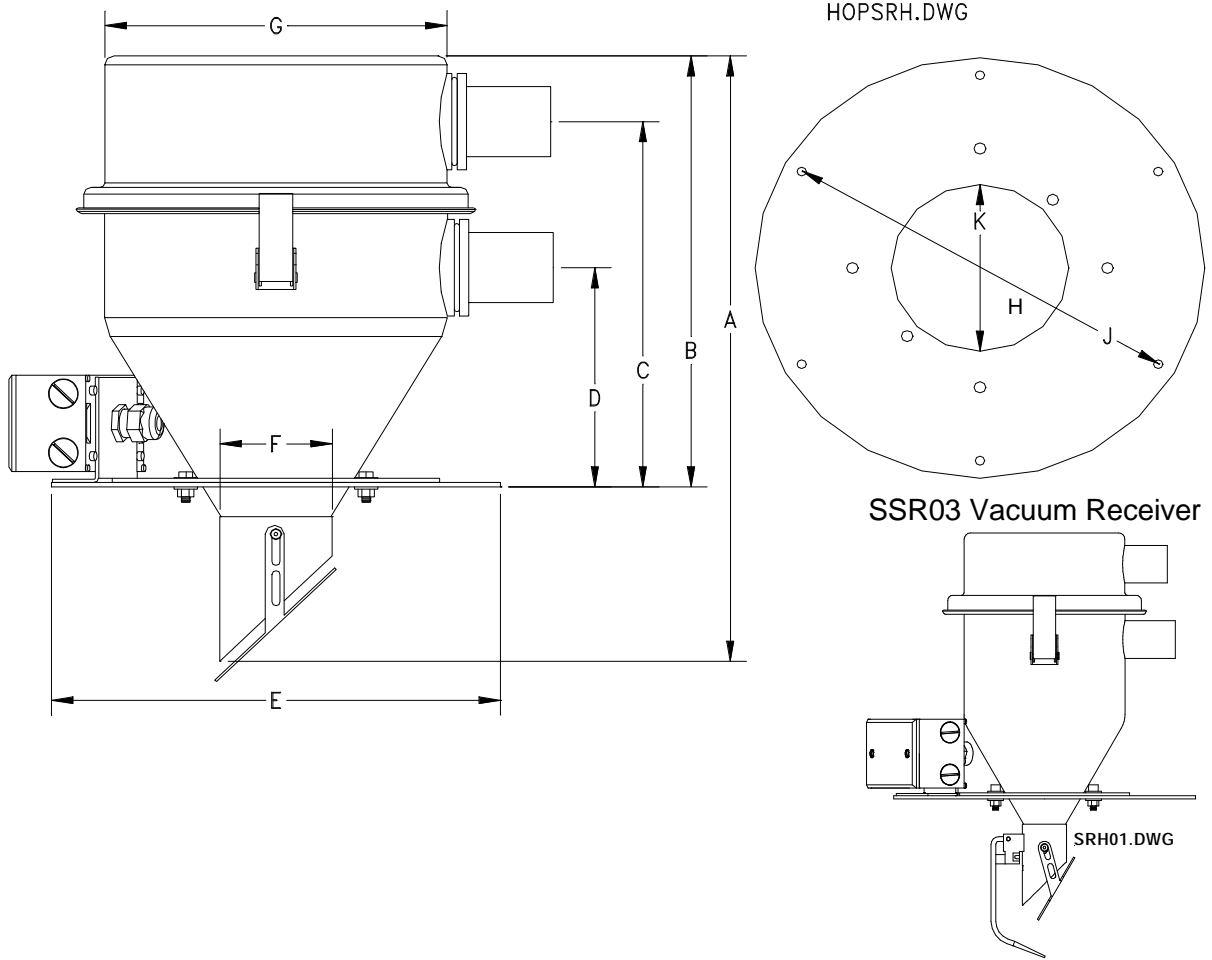

Model	Cu. ft.	Dimensions (inches)									
		A	B	C	D	E	F	G	H ^①	J ^②	K
SSR03	0.1	14.88"	10.63"	9.38"	6.38"	12"	1.75"	6.38"	5.50"	11"	6.75"

Model	Liters	Dimensions (cm)									
		A	B	C	D	E	F	G	H ^①	J ^②	K
SSR03	2.8	38	27	24	16	31	4.4	16.2	14	28	17

① $5/16$ "/0.3125" (8.00 mm) -diameter holes, two (2) places equally spaced.

② $1/4$ "/0.2500" (6.35 mm) -diameter holes, six (6) places equally spaced; **H** is standard mounting hole location.

Figure 9: SSR (6-45) Stainless Steel Vacuum Receiver Dimensions

Note: SSR45 Vacuum Receiver (shown)

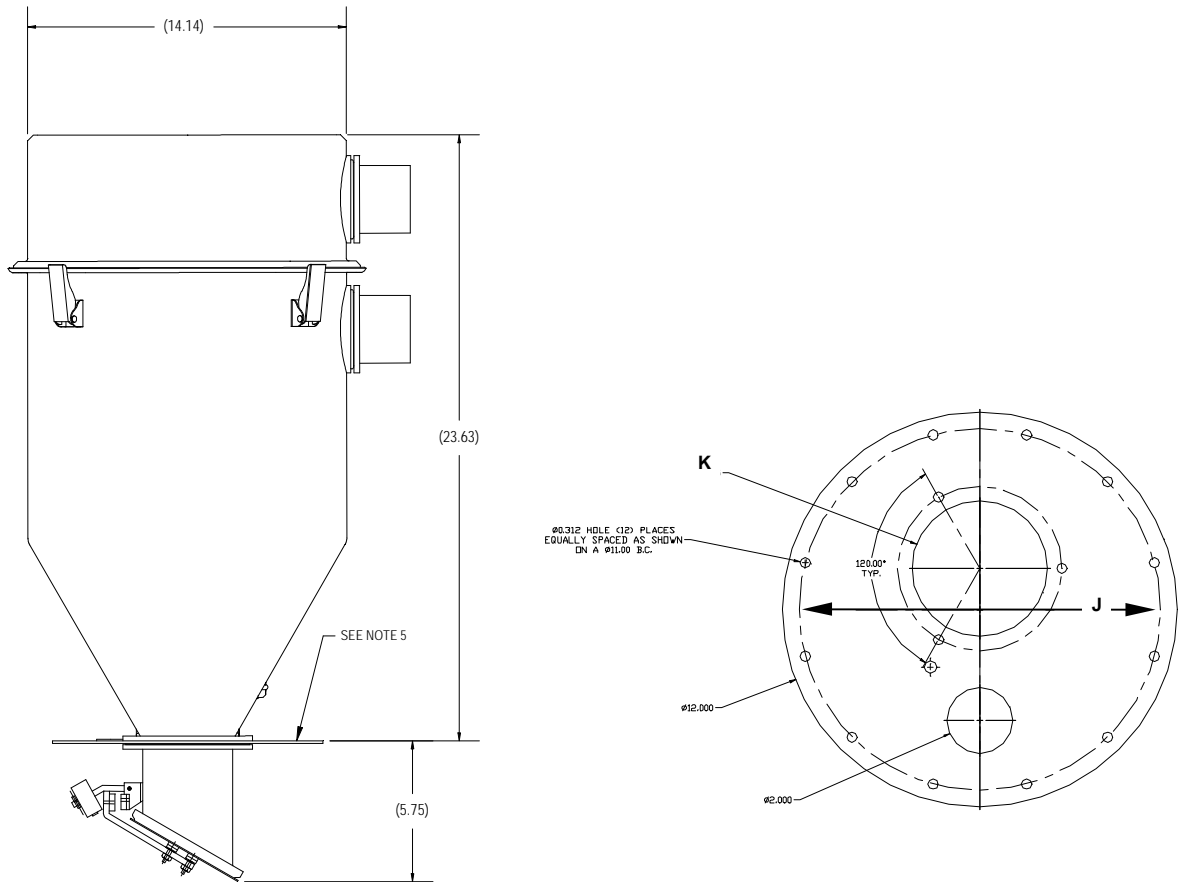

(Mounting Flange -10" Diameter Cut-Out)

Model #	Cu. ft.	Dimensions (inches)										
		A	B	C	D	E	F	G	H ①	I ②	J	K
SSR06	0.2	16.75"	11.5"	9.75"	5.5"	12"	4"	9.13"	N / A	11"	10"	4.5"
SSR11	0.4	22.38"	17.5"	15.38"	11.5"							
SSR23	0.8	26"	20.13"	17.38"	11.6"							
SSR45	1.6	32.25"	26.38"	23.63"	18.1"							

Metric Standards · Dimensions in cm

Model #	Liters	A	B	C	D	E	F	G	H	I ②	J	K
SSR06	5.6	42.5	29.2	24.8	14.0	30.5	10.2	35.9	N/A	27.9	25.4	11.4
SSR11	11.3	56.8	44.4	39.7	29.2							
SSR23	22.6	66.1	51.1	44.1	29.5							
SSR45	45.3	81.9	67.0	60.0	46.1							

① 5/16"/0.3125" (8.00 mm) -diameter holes, two (2) places equally spaced.

② 1/4"/0.2500" (6.35 mm) -diameter holes, six (6) places equally spaced; **I is standard mounting hole location.**

Figure 10: SSR (85/170) Stainless Steel Vacuum Receiver Dimensions

Note: SSR170 Vacuum Receiver (shown)

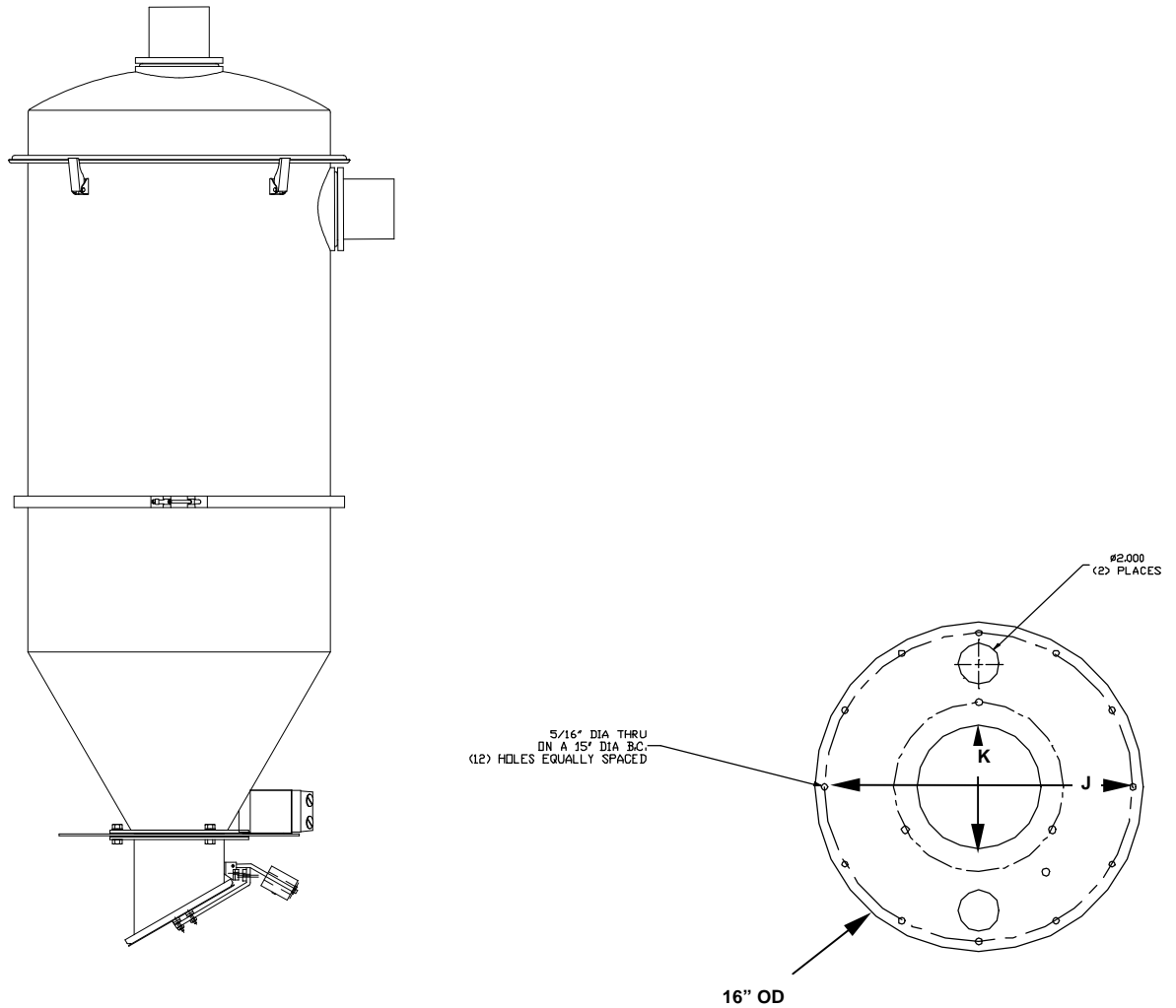

(Mounting Flange -14" Diameter Cut-Out)

Model #	Cu. ft.	Dimensions (inches)									
		A	B	C	D	E	F	G	H ①	J	K
SSR85	3.0	47	39	NA	26	16	6	20	NA	15	7
SSR170	6.0	63	55		42						

Metric Standards · Dimensions in cm

Model #	Liters	A	B	C	D	E	F	G	H	J	K
SSR85	85	119	100	N/A	66	41	15	51	N/A	38	19
SSR170	170	159	140		106						

① 5/16"/0.3125" (8.00 mm) -diameter holes, two (2) places equally spaced.

② 1/4"/0.2500" (6.35 mm) -diameter holes, six (6) places equally spaced; **I is standard mounting hole location.**

Atmospheric Valves

Models: AV1.5, AV2, AV2.25, AV2.5, AV3

- Mount on cover of vacuum hopper to direct vacuum into hoppers.
- Relieves vacuum by allowing an in-rush of atmospheric air into the system.
- Compressed air-operated.
- Selection of black or white neoprene plungers or available high temperature plungers.
- 24 VDC or 115 VAC control voltage solenoid.
- Adds only six inches (15 cm) to the height of vacuum hoppers and filter chambers.

Figure 11: Typical Atmospheric Valve

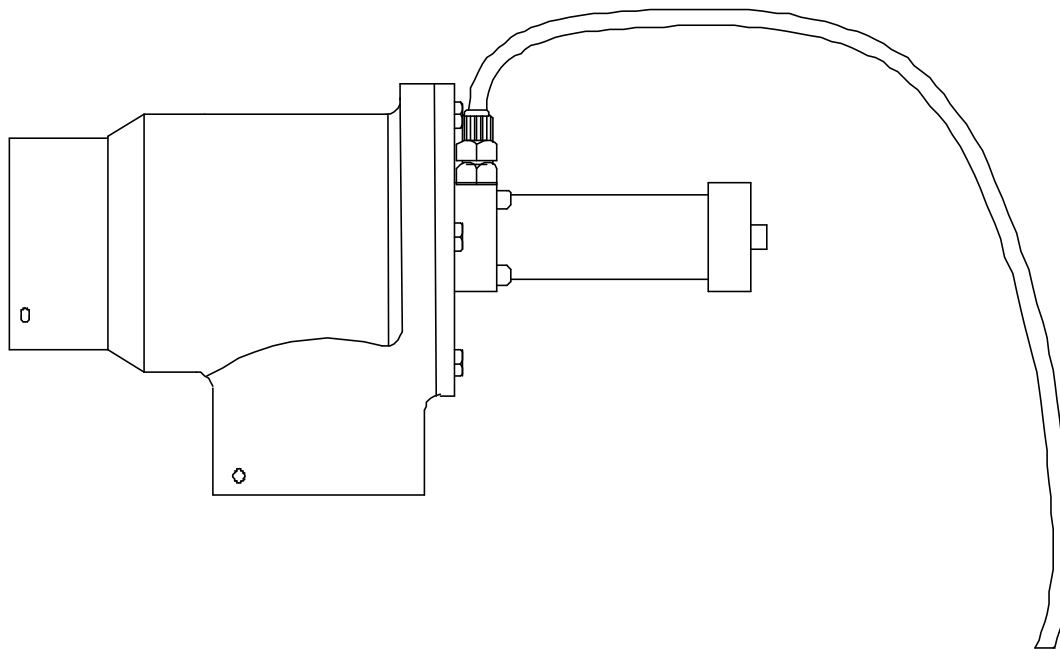

Sequence T-Valves

Models: SV1.5, SV2, SV2.25, SV2.5, SV3, SV4, SV4.5, SV5

- Mount in vacuum header piping above vacuum hoppers to direct vacuum into hoppers.
- Used with pumps that have blowback feature and critical dried resins because no atmospheric air is introduced when vacuum is relieved.
- Compressed air operation.
- Selection of black or white neoprene plungers, or high temperature silicone plungers.
- 24 VDC or 115 VAC control voltage solenoid.
- Distributed I/O capability.

Figure 12: Typical Sequence T-Valve

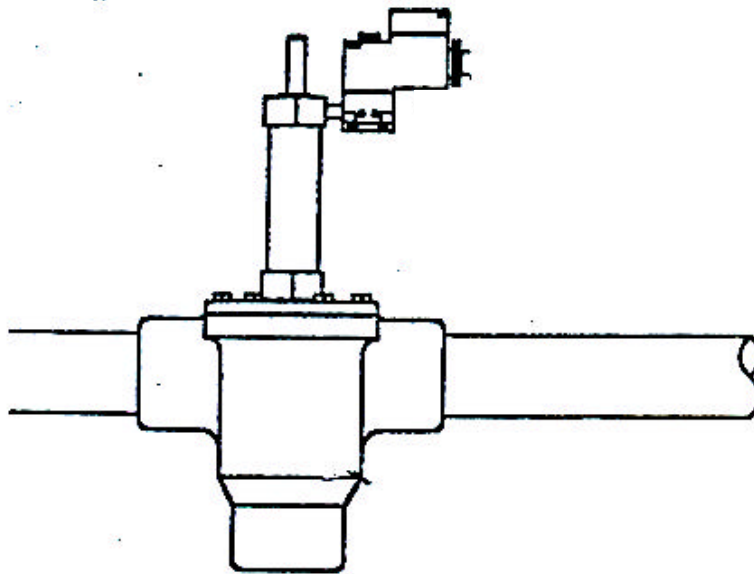

Cartridge-Style Vortex Filter Chamber

Models: SFC225, SFC1000

- For use with standard pumps.
- Two stage cyclone/cartridge filter design.
- Twenty-nine inch (29"/74 cm) -high floor stand for drum discharge.
- Reverse pulse filter element.
- Flapper dump valve and filter shroud.
- Available in mild (51) or stainless steel (52) construction.
- Compressed air filter cleaning 24VDC or 120VAC.

Options

- 45" (114 cm) floor stand with 38" (97 cm) clearance for 55-gallon (208-liter) drum.
- Removable dust can on 29" (74 cm) floor stand.
- Compressed air blowback with 115VAC/24VDC solenoid; controller available separately.

Figure 13: SFC Vortex Filter Chamber Specifications and Dimensions

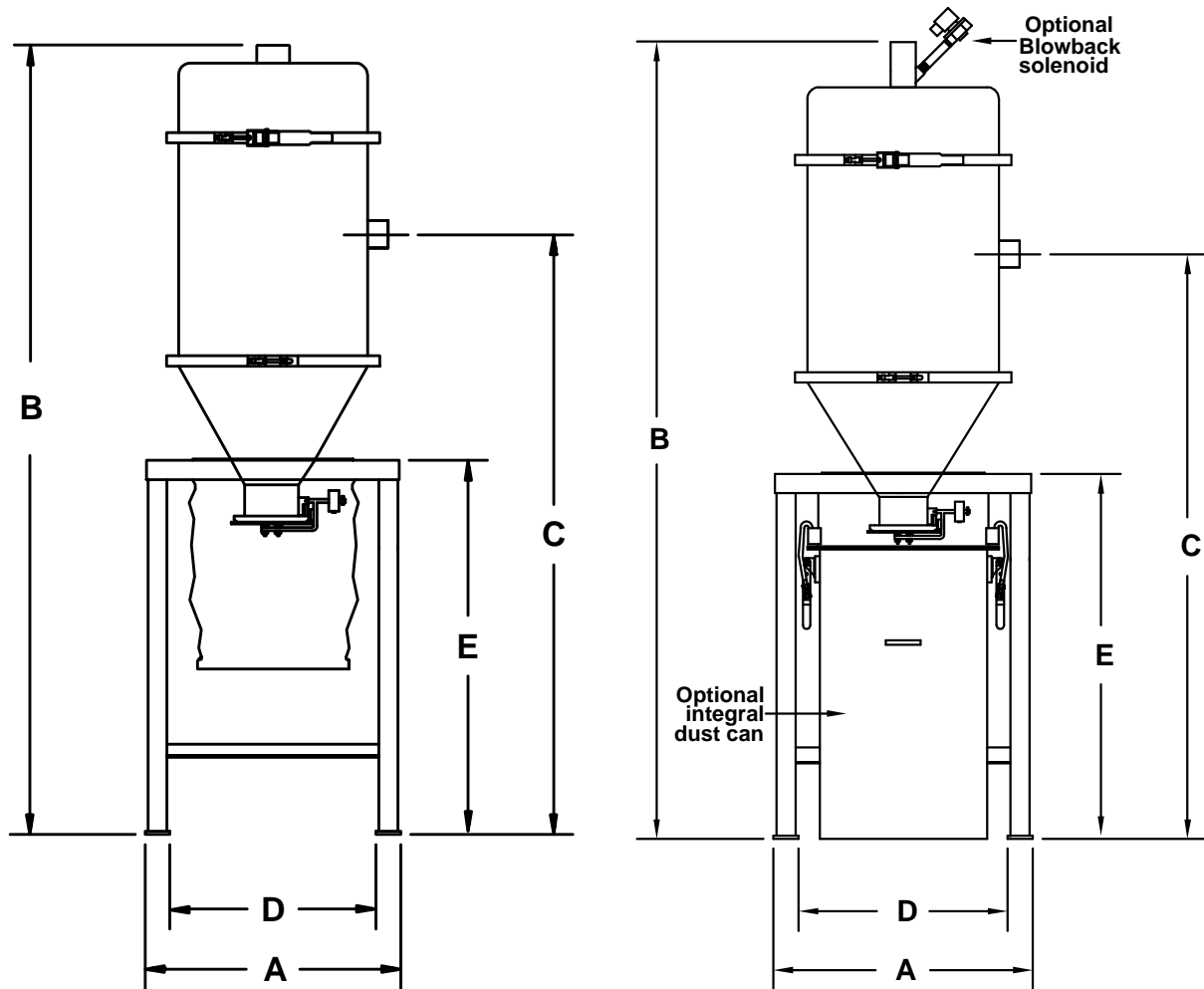

SFC-225	Floor stand	A		B		C		D		E	
		inches	cm	inches	cm	inches	cm	inches	cm	inches	cm
	29" (74 cm) stand	20.50"	52	67.50"	171	45.38"	115	16.50"	42	29"	74
	Optional 45" (114 cm) stand with drum	28.50"	72	83.50"	212	61.38"	156	24.50"	62	45"	114

SFC-1000	Floor stand	A		B		C		D		E	
		Inches	cm	inches	cm	inches	cm	inches	cm	inches	cm
	29" (74 cm) stand	26.50"	67	82.38"	209	50.38"	128	22.50"	57	29"	74
	Optional 45" (114 cm) stand with drum	34.50"	88	98.38"	250	66.38"	169	30.50"	77	45"	114

Note: Dimensions are approximate and subject to change without notice.

FC Series Bag-Style Filters

Models: FC15, FC30, FC55

- For use with power units equipped with blowback feature.
- Polyester felt bags are standard.
- Forty-five inch (45"/114 cm) floor stand with 38" (97 cm) clearance for 55-gallon (208-liter) drum.
- Available in floor-mount, floor stand with manual dump, or floor stand with flapper dump configurations.
- Spare filter bag rack with bags available.

Options

- Filter media available.
- Enclosed floor stand.

ACA Series Filter Chambers

Models: ACA51 Low Boy, ACA53 Low Boy, ACA91, ACA93, ACA131, ACA 133, ACA251, ACA253

- Self-cleaning design.
- Available construction in mild steel (-1 models) or mild steel with epoxy-coated interior (-3 models).
- Filter chamber section shipped completely assembled separate from the hopper section; mounting on hopper section required.

Figure 14: Typical ACA Series Filter Chamber

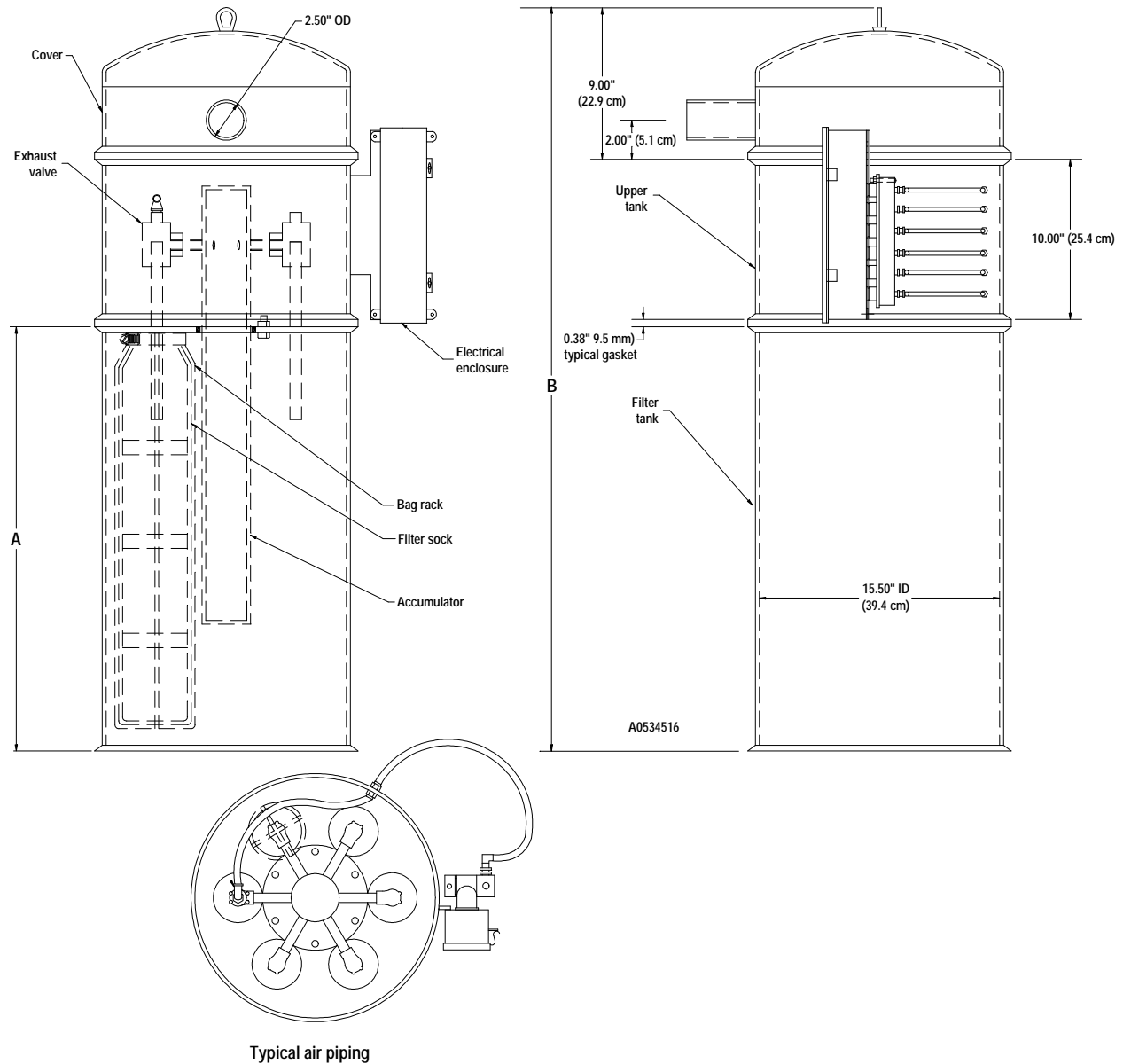

Note: *The 2.5" OD upper air inlet can be sized to vacuum system requirements using available transitions.*

Filter Tank, Overall Dimensions

ACA91, 93				ACA131, 133				ACA251, 253			
A		B		A		B		A		B	
in.	cm	in.	cm	in.	cm	in.	cm	in.	cm	in.	cm
19.5"	49.5	39.0"	99.1	26.5"	67.3	46.0"	116.8	49.5"	125.7	69.0"	175.3

SFC-S Series Filters

Figure 15: SFC-S Filter Compressed Air Blowback

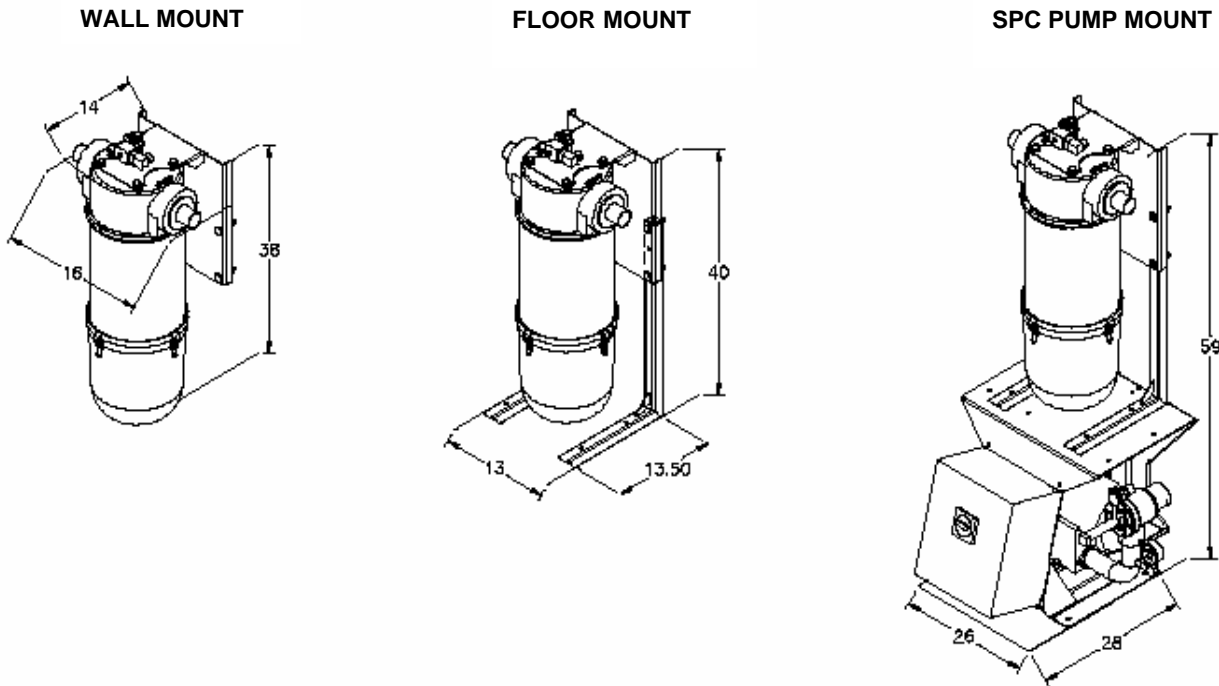

Model: SFC-S Filter

- Voltage: 24V DC (also available in 115V AC)
- Compressed air supply, 60-80 PSI (4.1-5.5 Bar)
- SPC pump mount, Wall mount or Floor mount
- See-through plexiglass collection bin with quick disconnects

Specifications and Dimensions:

Filter surface, sq. ft. (m ²)	50 (4.64)
Filter cleaning method	Compressed air or implosion blowback
Approx. weight, lbs. (kg)	70 (26)
Line sizes available	1.5, 2.0, 2.5, 3.0, 3.5 (2 Sch. 5), 4.0

Note:

1. *Implosion style filter cleaning option may be available but requires a special control system. Consult factory.*
2. *The SFC-SC cyclonic pre-filter is also available. Consult factory for more information.*

Figure 16: ACA Series Model 51 and 53 Low Boy Filter Assembly

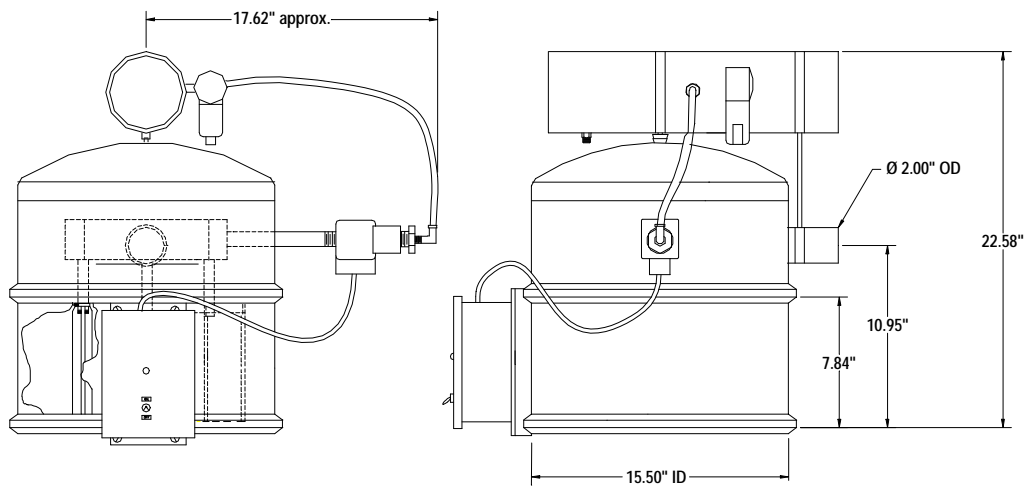

Note: *The air inlet can be sized to vacuum system requirements using available transitions.*

Take-Off Compartments and Pickup Tubes

Take-Off Compartment Models:

- Grinder Takeoff Attachment style,
- Filtered Expandable Vacuum Takeoff (FEVTO) style,
- Expandable Vacuum Takeoff (EVTO) style,
- Cleanout style
- Box style
- Fast Cleanout Vacuum style
- MTO
- MDT
- FCO

Figure 17: Typical Grinder Take-Off Attachment

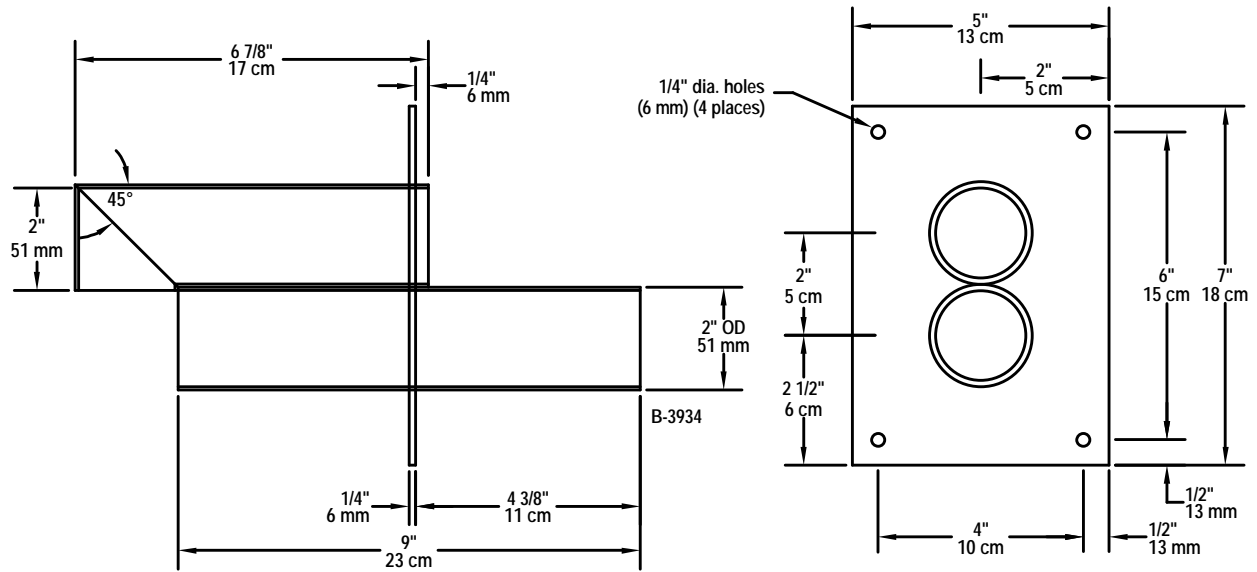

Figure 18: Typical Take-Off Compartment

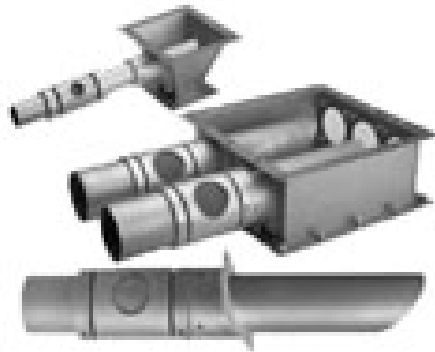
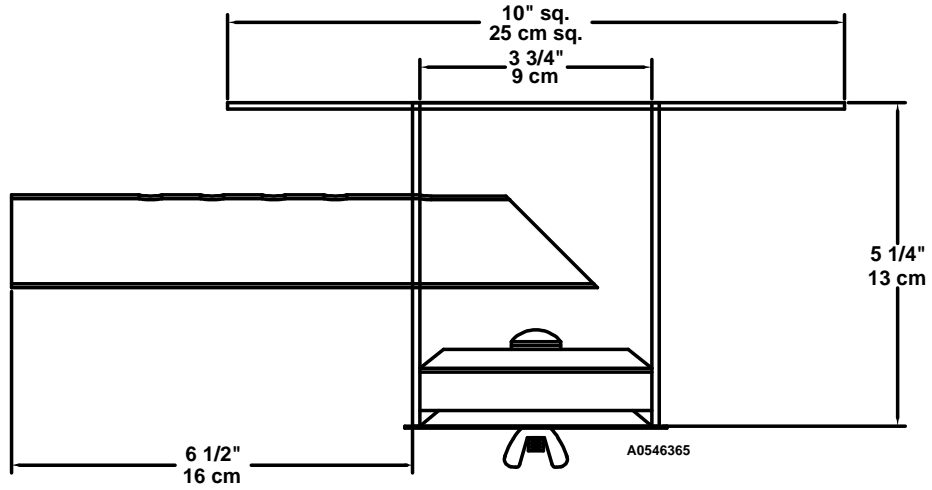
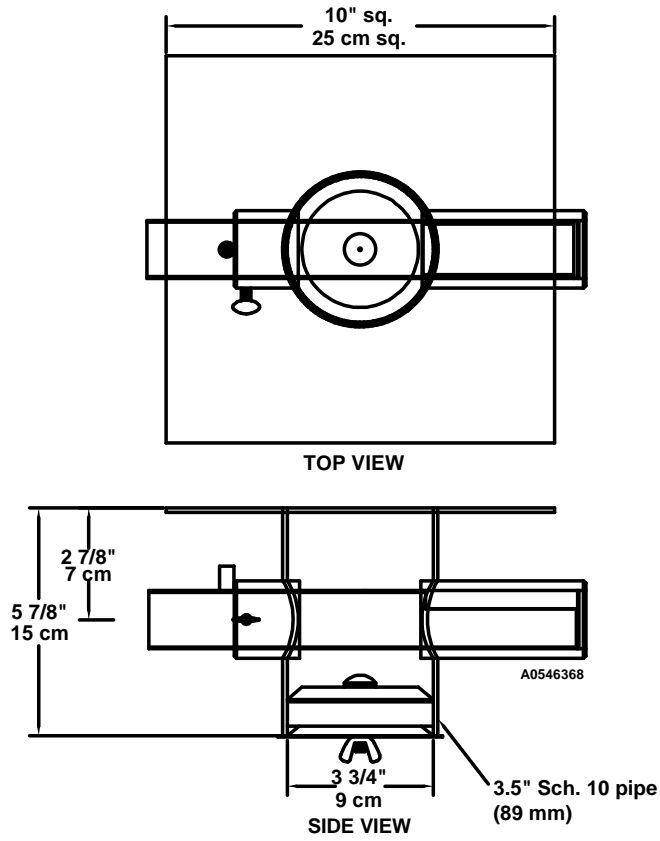

Figure 19: Typical Fast Take-Off Compartments (not to scale)

FCO-1.5M



FCO-1.5MD



Pickup Tube Models: Single and dual tube pickup tubes available.

Figure 20: Typical Pickup Probe

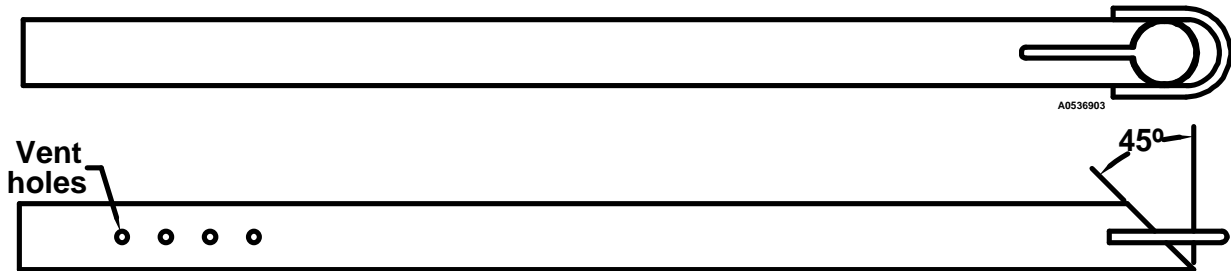

2-4 Safety Devices and Interlocks

This section includes information on safety devices and procedures that are inherent to the mechanical components of the conveying system. This manual is not intended to supersede or alter safety standards established by the user of this equipment. Instead, the material contained in this section is recommended to supplement these procedures in order to provide a safer working environment.

At the completion of this section, the operator and maintenance personnel will be able to do the following:

- Identify and locate specific safety devices.
- Understand the proper use of the safety devices provided.
- Describe the function of the safety device.

Safety Circuit Standards

Safety circuits used in industrial systems protect the operator and maintenance personnel from dangerous energy. They also provide a means of locking out or isolating the energy for servicing equipment.

Various agencies have contributed to the establishment of safety standards that apply to the design and manufacture of automated equipment. The Occupational Safety and Health Administration (OSHA) and the Joint Industrial Council (JIC) are just a few of the organizations that have joined with the plastics industry to develop safety standards.

Every effort has been made to incorporate these standards into the design of the mechanical components of the conveying system; however, it is the responsibility of the personnel operating and maintaining the equipment to familiarize themselves with the safety procedures and the proper use of any safety devices.

Fail Safe Operation

If a safety device or circuit should fail, the design must be such that the failure causes a "Safe" condition. As an example, a safety switch must be a normally open switch. The switch must be held closed with the device it is to protect. If the switch fails, it will go to the open condition, tripping out the safety circuit.

At no time should the safety device fail and allow the operation to continue. For example, if a safety switch is guarding a motor, and the safety switch fails, the motor should not be able to run.

Safety Device Lock-Outs

Some safety devices disconnect electrical energy from a circuit. The safety devices that are used on the mechanical components of the conveying system are primarily concerned with electrical power disconnection and the disabling of moving parts that may need to be accessed during the normal operation of the machines.

Some of the safety devices utilize a manual activator. This is the method of initiating the safety lock out. This may be in the form of a plug, lever or a handle. Within this lockable handle, there may be a location for a padlock. Personnel servicing the equipment should place a padlock in the lockout handle.

In addition to the safety devices listed above, these mechanical components are equipped with a line cord plug. This allows the operator or maintenance personnel to unplug the system from its power source and tag it out. The plug can then be tagged with any number of approved electrical lockout tags available at most electrical supply stores.

WARNING! *Always disconnect and lockout all electrical power and pneumatic (i.e. compressed air) sources prior to servicing or cleaning the conveying system. Failure to do so may result in serious injury. No one but the person who installed the lockout may remove it.*



Chapter 3: Installation

3-1 Uncrating the Equipment

The mechanical components of the conveying system are shipped mounted on a skid, enclosed in a plastic wrapper, and contained in a cardboard box.

1. Pry the crating away from the skid.

Note: *Remove the nails holding the box to the skid and lift the box off carefully; avoiding staples in the 1' x 4' wood supports. Cut the steel banding.*

2. Use a pry bar to remove the blocks securing the unit to the skid.
3. Lift unit from sides, inserting forklift under the base. The forks must be equidistant from the centerline of the unit and the unit must be balanced on the forks. Lift slowly and only high enough to clear the skid. Use a pry bar if necessary to carefully remove the skid from the unit.
4. Lower slowly.
5. Temporary hardware has been installed to prevent side panels from shifting in transit. Remove hardware.
6. Retain the crating material for reshipping the components in case hidden shipping damage is found.

3-2 Rigging and Placing Mechanical Components

Conveying system installations vary depending on the application: in-plant distribution or rail car unloading, single or multiple material line systems, pellets, or powders. The sections on the following pages are general installation guidelines.

Installing the Pump Package

Place the vacuum pump where you can have easy access to the mechanical components. Choose a clean, dry place where debris won't be drawn into the vent valve on top of the blower. If you install the unit outside, you must provide a weather shed to shelter the unit.

1. Level the vacuum pump package. Use shims as needed.
2. Secure the vacuum pump package with appropriately-sized bolts to the floor or mounting platform.
3. Do not twist or warp the pump package base. This can misalign the blower housing and damage the blower.

Vacuum Pump Vent Piping Considerations

Most vacuum pumps are installed with no exhaust venting of the vacuum pump discharge. If your installation requires vacuum pump exhaust venting, follow these guidelines:

- Venting exhaust air from vacuum pumps requires the installation of metal pipe or ducting. Make sure that no more than two inches water column (2" WC or about 0.5 kPa) backpressure is present at the discharge of the vacuum pump silencer.

Note: *Improper sizing or ducting of exhaust air voids your warranty!*

- Use piping or ducting at least two (2) diameter sizes larger than the vacuum connection. Overall vent pipe length—horizontal plus vertical—should not exceed 100 feet (about 30 m) and should not include more than three (3) elbows. If you use pipe for venting, make sure that you use Sch. 5 or Sch. 10 pipe with long radius elbows to provide minimum airflow resistance. If you use ducting, make sure you use high-pressure ducting with mitered bends—with a minimum of three (3) breaks—for minimum airflow resistance. Make sure all piping connections are properly supported.
- If you are venting pump discharge outdoors, make sure you properly terminate vent piping to prevent pump damage. You can either:
 - a. Install a rain cap, or
 - b. Install the piping so the exhaust faces down and terminates with a screened opening.

Note: If the pump becomes contaminated from rain or airborne particulates, or is damaged by birds, insects, or small animals, your warranty becomes void!

Any variance from these guidelines can cause excessive pump backpressure. Such a condition can drastically affect equipment performance, possibly leading to equipment damage.

Figure 21: Filter Chamber Installation, Optional Blowback Controller Shown

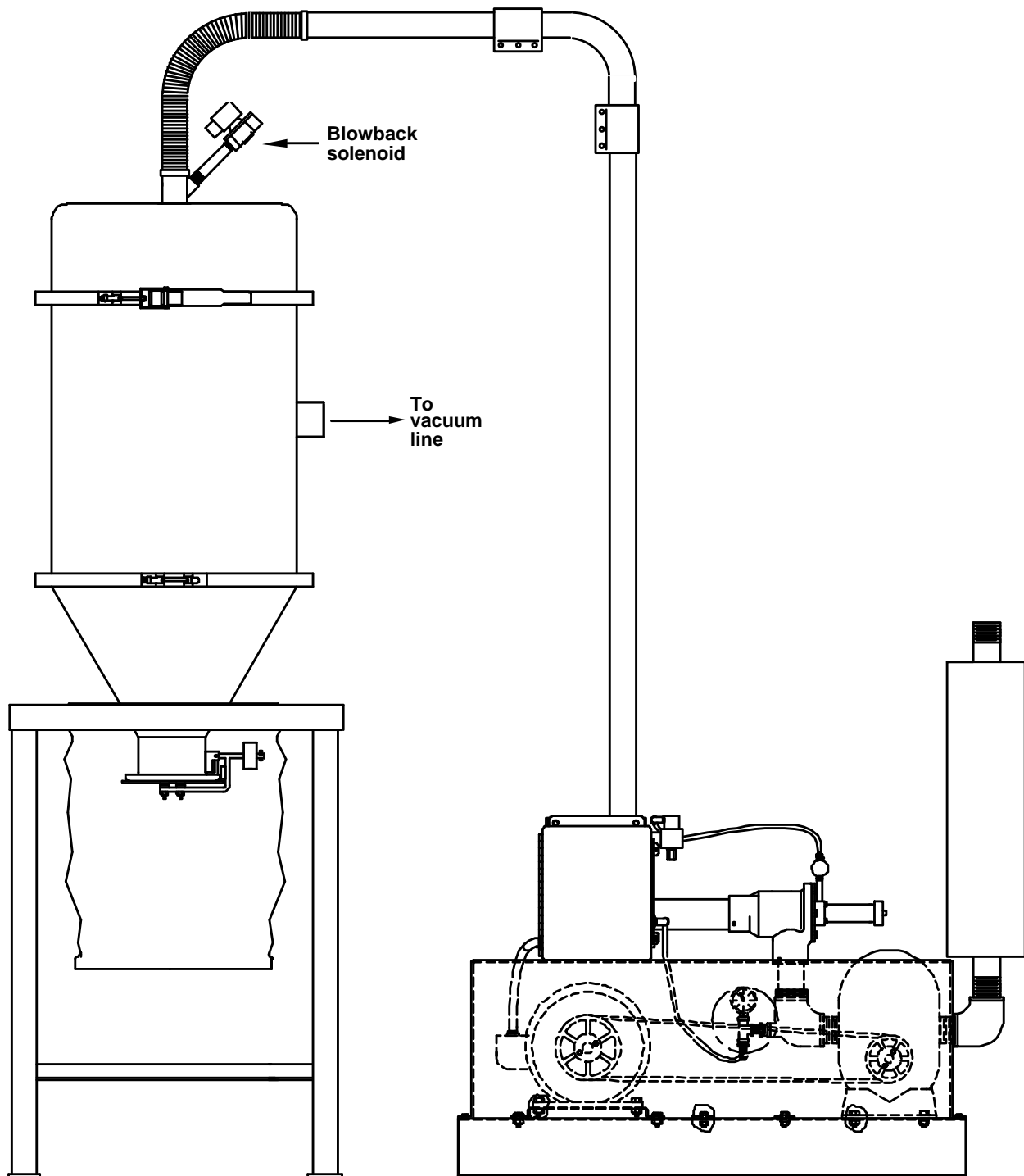

Note: Make sure you have all tubing supported at ten (10) foot (3 meter) intervals.

Installing the Control Panel

Select a flat, vertical area for mounting the panel. It should be in an area that gives your operator access to the control. Consider how you are running wiring to the vacuum hoppers, the filter chamber, and pump motor starter(s), vacuum switch(s), and vent valve(s). The panel requires a low voltage grounded power drop as listed on the serial tag.

Note: Avoid mounting control panel near material lines.

Installing Material/Vacuum Tubing

Well-designed material/vacuum piping systems provide the best conveying rates. Vacuum/material piping may be a single material line Y system or a multiple material line or a combination of the two systems, depending on the processing floor layout. All systems utilize a common vacuum header line for all stations connected to a pump package; material flow is controlled by sequence T or atmospheric valves operated by the control panel. When installing material/vacuum tubing, take the following into consideration:

- Vacuum leaks anywhere in the system reduce system capacity.
- Keep the number of material tube bends, elbows, Y-tubes, and vacuum T-tubes to a minimum for maximum system capacity.
- Use long radius tube bends on material lines.
- Keep the total length of material conveying flex hose to a minimum. Long flex hose material runs reduce system capacity.
- Vertical material tubing runs should be straight up. Inclined runs can reduce capacity.
- Support tubing about every ten feet with straps, pipe hangers, or brackets.
- Tube joints must be rigid to prevent vacuum or material leaks.
- Cut tube ends square and chamfer edges smooth. Use a fixed band saw or power miter saw when making cuts. You can use a tubing cutter on aluminum tubing, but you need to use a saw with a carbide or diamond-impregnated saw blade when cutting stainless steel. Chamfer outer and inner edge cuts with a die grinder or a hardened rasp file.
- Clean all tubing after cutting and before assembly. Dampen a rag in a non-volatile cleaning solvent, and run it through all tubing and couplers to remove sediment from shipping or cutting. Run a quantity of low-grade material through new lines to remove any remaining sediment, and then discard the material immediately.
- Tube ends must butt together inside couplers.
- Tighten tube coupler nuts from the center outward to ensure a tight seal and allow proper contact of the internal grounding strip.
- Each material tubing run must maintain an electrical continuity through the tubing and couplers, from pickup point to vacuum hopper. Grounded flexible hose is recommended.
- If you must cut bends, cut the straight section, leaving enough straight length for complete insertion into a coupler.

- You can attach a quick-change or standard tube coupler to vinyl flex hose by inserting a stub of hard tube into the hose and securing it with a hose clamp. Be sure enough tube extends from the hose to properly install the quick-change or coupler. Make sure that you put clear silicone caulk around adjoining tube seams for exterior bolted couplers.
- If you use stainless flexible material hose, the material flow must be in the direction as indicated by the arrows on the hose. Material direction is not critical with vinyl flex hose.
- Bring all truck fill lines to a central location, such as a silo, unless otherwise specified.
- All rail car manifold Y-tubes must be installed with a ten-degree (10°) downward slant from horizontal on the leg section. Make sure that space between rail car manifold Y-tubes are fifteen feet (15'/4.5 meters) on center to allow proper alignment between rail car discharge ports and the manifold Y-tubes.
- A plug must be put in the last sequence T valve on the vacuum header to prevent vacuum loss. If atmospheric valves are used, you must terminate the vacuum line at the last atmospheric valve.

Multiple Line System Piping Considerations

- Multiple line systems have separate material lines for each material to allow different types of materials to be conveyed.
- Multiple line systems have separate pickup devices for each vacuum hopper.
- Materials are often loaded from beside the processing machine from gaylords, grinder takeoffs, and storage bin takeoffs.

Figure 22: Typical Multiple Line System Installation

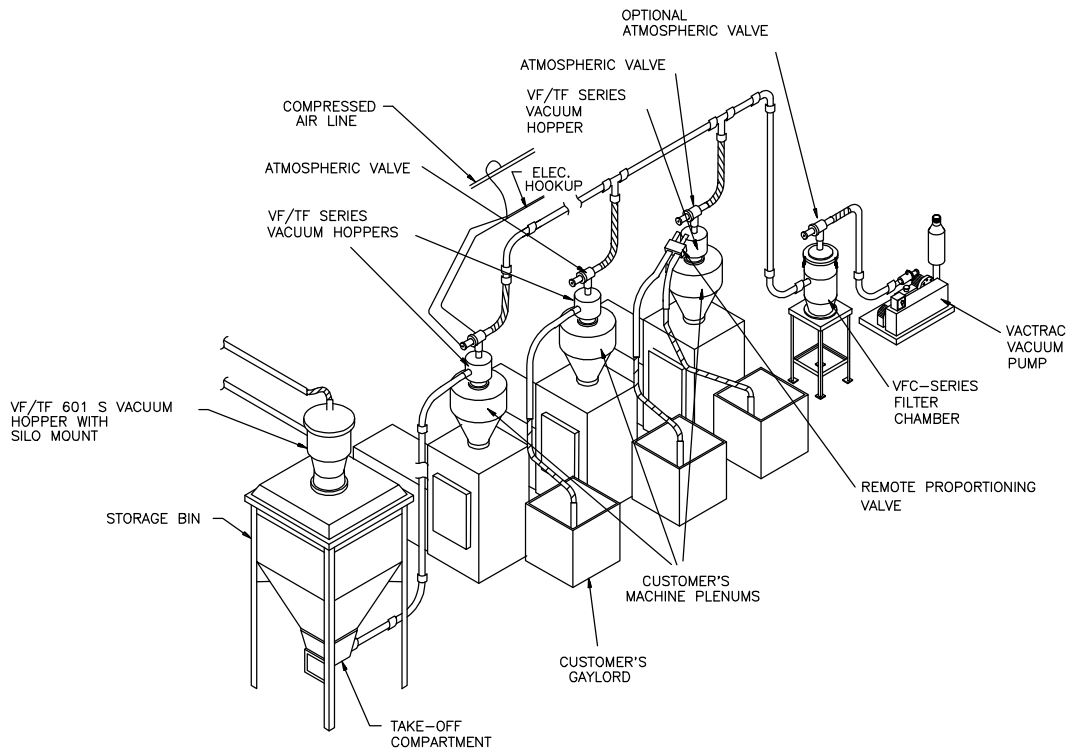

Single Line Y-Tube System Considerations

- Single line Y piping systems use a common material line for all vacuum receivers connected to a pump and are typically used to convey material from a central supply to several stations.
- If you are installing a single line Y system, use Y tubes on the material lines. A Y tube is installed with the branch arm leading to the next station on top and the straight portion that supplies material to the station underneath.
- Connect a short-radius bend to the straight portion as close to the Y as possible.
- You must connect a minimum 2-foot (61 cm) straight length of tube to this short radius bend on the horizontal before the material tubing drops to the receiving point. If possible, incline this tube approximately $\frac{1}{8}$ " per foot (1 cm per meter).
- On single line Y systems, you must install check valves on material inlet tubes inside vacuum receivers.

Note: *Do not use SSR03 or SSR06 vacuum receivers on single line Y systems.*

- You can install a long- or short-radius bend on the last station, where a Y-tube is not needed.

Figure 23: Recommended Single-Line Y-Tube Installation

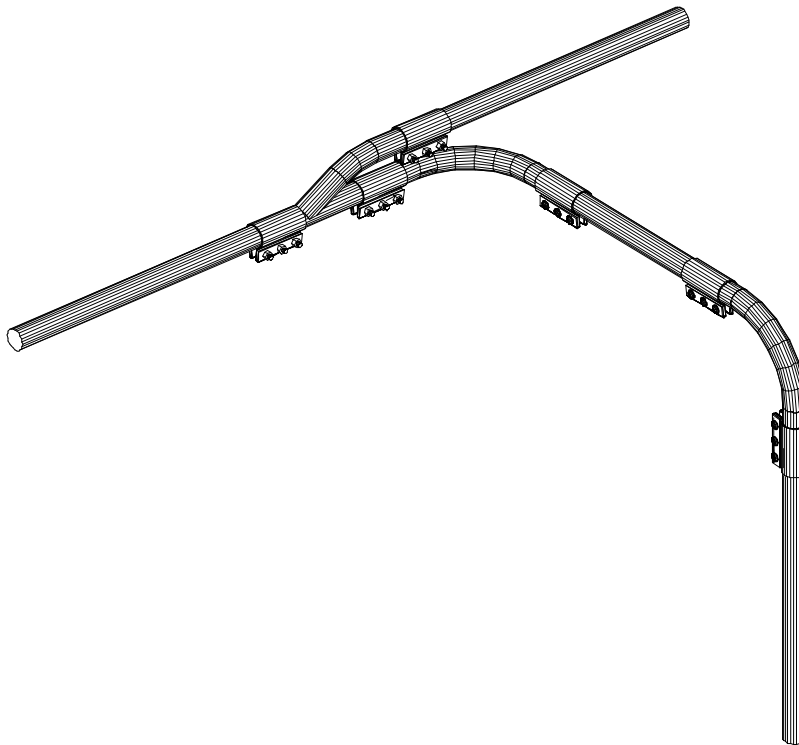

Figure 24: Modified Single-Line Y-Tube Installation

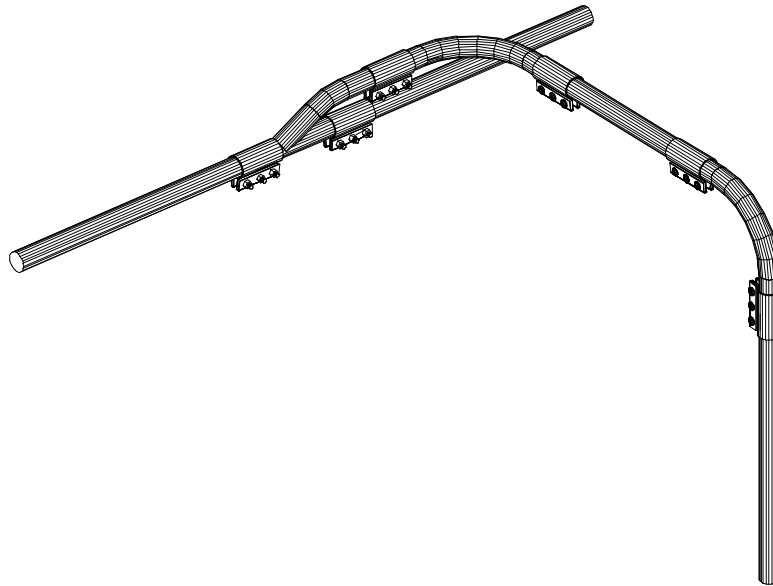

Figure 25: Manifold Y-Tube Installation

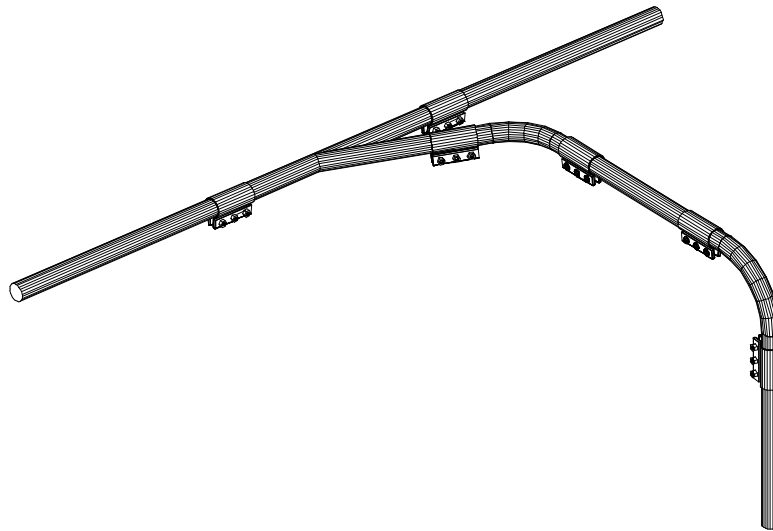
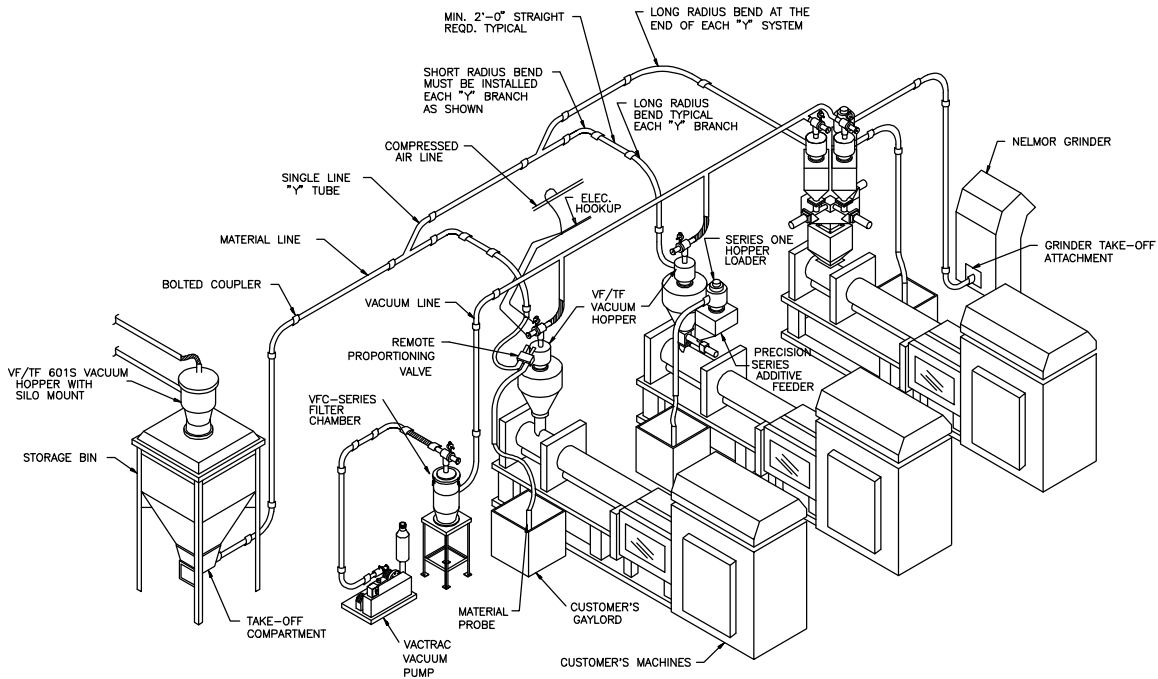

Figure 26: Typical Single Line Y-Tube System Installation



Material Check Valves in Single Line Y-Tube Systems

- Check valves are a critical feature on single line Y systems. You must have a check valve installed on the material inlet inside the receiver on all vacuum hoppers in single line Y installations.
- Check valves must open when the receiver is being loaded and seal to prevent a vacuum leak when other hoppers are being loaded.
- Vacuum receivers for these systems have a special factory-installed extended material inlet tube to hold the check valve.
- The check valve must not be pressed too far onto the inlet stub to prevent proper sealing.
- The hinge of the check valve should be up to prevent material from being deflected up into the vacuum hopper filter.
- Do not allow vacuum receivers with check valves to be over-filled to a point above the bottom of the check valve. Over-filling prevents the check valve from sealing and creates a vacuum loss. Adjust the conveying time on Time-Fill systems to prevent this from happening.
- Inspect periodically for erosion or wear. Replace as required.

Figure 27: Typical Material Check Valve

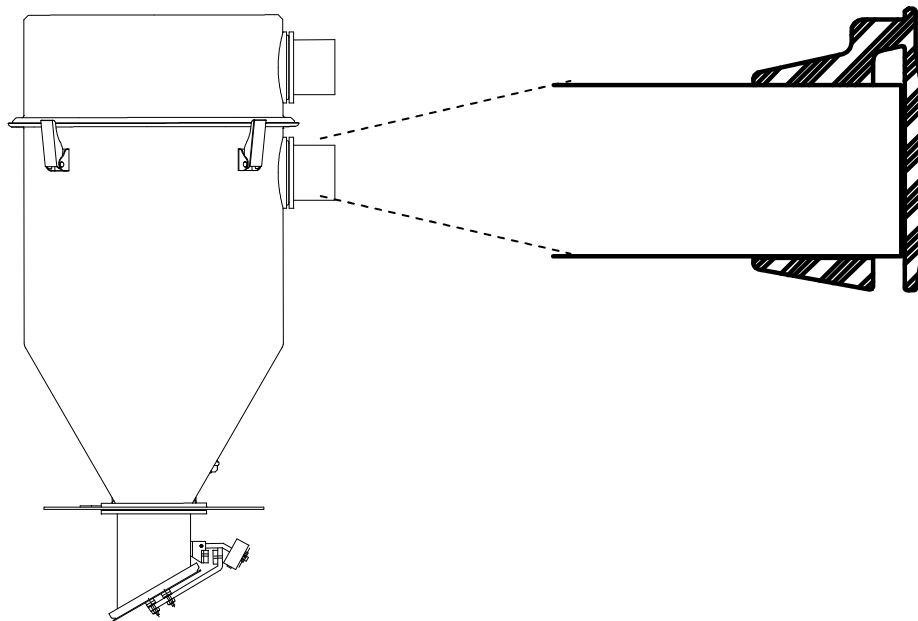

Installing SFC or FC Filter Chambers

The filter chamber protects the vacuum pump from damage caused by material carry-over. Primary system filtration occurs in the filter chamber, not in the vacuum receivers. This reduces maintenance of vacuum receiver filters atop processing machines.

A vortex created in the filter chamber separates carry-over from the air stream and a cartridge-type filter catches any dust and fines drawn into the upper chamber.

At the end of the conveying cycle to all on-line vacuum receivers, the dump delay cycle occurs. Atmospheric air from the vacuum line is introduced to the filter chamber, equalizing the pressure inside the filter chamber. The material discharge flapper valve falls open and dumps the fines and dust collected during the conveying cycle.

A compressed air filter cleaning blow back option is available for systems conveying very dusty materials (See Figure 32 on page 65 for example). Consult the Sales Department for more information. To install the unit, perform the steps listed below:

1. Level and secure the filter chamber near the pump package. Use 3/8" (9 mm) bolts to anchor the filter chamber.
2. Connect the piping between the vacuum inlet valve on the pump package and the tube stub on the filter chamber lid. For easy filter maintenance, install at least three feet (3' / 1 m) of vinyl flex hose at the end of the run to the filter chamber. The rest may be hard piping as long as it is properly supported.
3. Run vacuum tubing from the tangential inlet tube to the vacuum header line servicing the vacuum hoppers. Turn the inlet tube toward the header. Support the tubing properly and make it vacuum-tight.

Note: *Use of a system without an approved filter system installed on the vacuum air inlet voids the blower warranty!*

Installing the Filter Chamber Shroud

The cloth filter shroud is mounted to a ring on the underside of the filter chamber stand. It reduces housekeeping duties around the filter chamber by preventing dust from becoming airborne when the dust and fines are discharged from the SFC filter chamber. The dust container below the shroud is customer-supplied—the standard 24” (61 cm) clearance stand is designed for use with a 5-gallon (19-liter) pail, and the optional 38” (96 cm) clearance stand is designed for use with a 55-gallon (208-liter) drum.

1. Insert the filter shroud support wire into the slotted hole in the middle of the cloth filter shroud. Use supplied hardware to secure.
2. Slip the filter shroud over the retaining ring located on the bottom side of the filter stand mounting plate. Secure it with the worm clamp provided.
3. Place the dust container you’ve supplied below the filter chamber stand and insert the filter shroud.
4. On standard 5-gallon (19-liter) pails, the filter shroud should be trimmed and fastened to the top lip of the can with a band clamp. Don’t trim the filter shroud on 55-gallon (208-liter) drums. Secure the drawstring on the shroud around the drum, making sure the open end of the shroud hangs freely inside the drum.
5. Make sure the operation of the counterweighted flapper dump valve is not obstructed in any way by the filter shroud. See Figure 21 on page 47 for a typical example of a filter chamber shroud.

Caution! *Do not obstruct the filter shroud in any way. Empty the dust container before the dust level obstructs the end of the filter shroud. Failure to observe these directives may result in reduced filtering efficiency and contaminants entering the conveying system.*

Installing ACA Series Filter Chambers

Powders or granular materials with fines can cling to filters and contaminate operating components. The ACA Series filter chamber is a self-cleaning filtration unit that enables such materials to be conveyed.

During material conveying, fines accumulate on the outside of the filter media as the air passes through a filter bag. These fines must be periodically removed to prevent performance losses in the conveying system. The ACA Series filter utilizes a plant-based compressed air supply to clean filter bags with intermittent air pulses.

At preset time intervals, a solenoid valve activates, interrupting continuous compressed air flow to the unit. This interruption causes an exhaust valve to open, allowing stored compressed air from an accumulator to be released down inside the filter bag. This momentary burst of air stops the flow of dust-laden air through the filter bag and flexes the filter fabric. This, along with the reverse flow of air, causes the accumulated dust to fall off the bag and back into the hopper for discharge.

This instantaneous cleaning action of air pulses are directed to each individual filter bag in sequence and at a specified duration. You can adjust the time between air pulses; different conveying rates and materials require different air pulse times. Air pulses must occur more

frequently with increased dusting conditions. Since filter cleaning action is directed to an individual filter bag, remaining filter bags are on-stream, continually filtering conveying air.

ACA Series filter chambers are shipped completely assembled to reduce customer installation time. Several mounting arrangements are available, depending on the mounting adapter supplied with the unit.

ACA filter chambers are used with several different sizes of vacuum hoppers, depending on the mounting adapter supplied with the unit. Typical hopper sizes range from 0.8 cu. ft. to 6.0 cu. ft. (22.7 liters to 169.9 liters); smaller hopper installations are also possible. You must install a bottom flange adapter when mounting the filter chamber to the vacuum hopper. The adapter increases overall height of the filter chamber unit; this may affect where you install the unit.

Installing Vacuum Receivers and Inventory/Vacuum Receivers

Vacuum uses one of three mounting systems: flange, suspension, or silo mounting. Vacuum receivers and inventory vacuum receivers use flange mountings only.

- Remove all rubber banding and any other packaging materials from around the flapper dump valve *before* installation for proper operation.

Complete the vacuum and material tubing to the vacuum receivers. Final connections are usually made with flexible hose.

Note: *On single line Y systems, you must install a check valve on the material inlet of each hopper.*

Installing the Safety Filter

Use the following procedure to install the safety filter:

1. Place the safety filter in the conveying system directly before the vacuum pump.
2. Using 7/16", Grade 5 or better hardware, secure the filter in place:

Wall Mount. Use the mounting flange to secure the filter to the wall.

Floor Mount. Bolt the floor stand to the ground.

Pump Mount. Bolt the pump and stand to the ground. Pump-mount is only available with SPC pumps.

WARNING! *Make sure all screws are strong enough to hold the weight of the filter.*

- Connect the vacuum line to the filter chamber's inlet tube (A). Use a hose clamp to secure the flexible hose.
- Connect the vacuum pump line to the outlet tube (B). Use a hose clamp to secure the flexible hose.

Figure 28: SFC-S Filter Installation

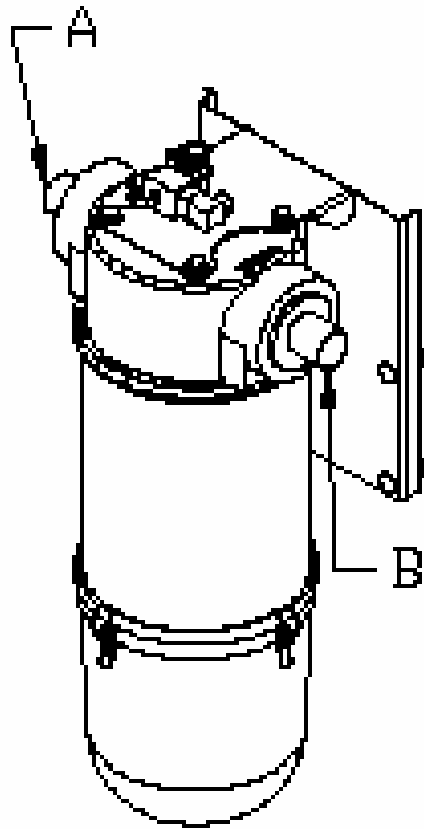

3-3 Compressed Air Blowback Connection

To provide proper filter element cleaning, the compressed air supply must be regulated to 80 PSI (5.5 bars). Low air pressure will cause poor filter element cleaning. Air consumption depends on the frequency and length of cleaning air pulses into the filter element.

Connect a minimum of 3/8" (9 mm) air line to the top of the solenoid valve air block. Compressed air must be clean, dry, and free of oil. A filter regulator and shut-off are recommended components of your in-plant air supply. In-line filters can handle small amounts of moisture; in-line desiccant filters or packed beds of granular absorbing polymer can remove oil mist and condensed oil.

You may need to install an accumulator in your air supply system to enhance blowback effectiveness if your system cannot consistently meet these requirements. Make sure you use full-sized 3/8" or larger diameter pipe or tubing when making the connection.

3-4 Implosion Blowback Connection

The clearing valve (implosion blowback valve) is located on the outlet of the vacuum filter. Connect the clearing valve to a 60-80 PSI (4.1-5.5 Bar) compressed air supply. Compressed air must be clean, dry and free of oil.

Run a 3/8" (9 mm) branch line to supply the vacuum hoppers in your system. Install a 3/8" (9 mm) x 1/8" (3 mm) tee valve in the up position near the filter chamber.

Connect shop compressed air to port number 3 on the clearing valve solenoid with 1/4" (approx. 6 mm) poly tubing. Connect port number 2 to the clearing valve. Port 1 is to be exhausted to the atmosphere. (See Figure 29 below).

The 3/8" (9 mm) branch supply line should include a shut-off valve for on/off control, an air filter/pressure regulator with a gauge for pressure control, and mini-lubricators located at each vacuum receiver. Install a quick-disconnect fitting or a shut-off valve in the compressed air piping leading to the vacuum receiver's clearing valve to speed receiver cover removal for cleanout or service.

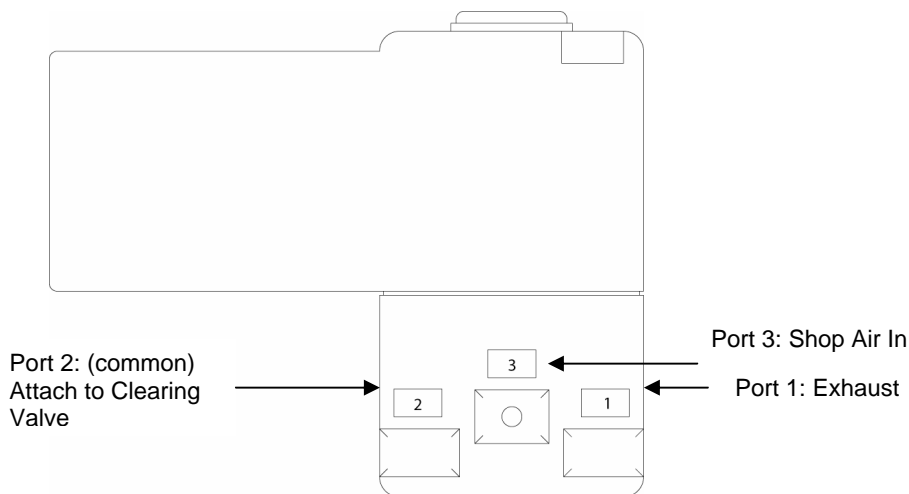

Figure 29: Clearing Valve Compressed Air Connections

Flange Mount Vacuum Receiver Mounting

These units are designed to fit in existing equipment with standard 10” mounting holes that will accept our vacuum receivers.

- ☑ For new installations, the recommended cut-out is a 10” (25.4 mm) –diameter round hole with six (6) mounting holes equally spaced on an 11.0” (279.4 mm) OD bolt circle. The factory provides 5/16” holes on the mounting flange to allow proper bolt clearance.

Orienting the Unit

The factory provides (12) mounting holes locations on the 11.0” (279.4 mm) OD mounting bolt circle. Under most conditions, using six (6) of the mounting holes with the proper hardware is sufficient to secure the unit to other equipment.

- ☑ Make sure that mounting hardware is equally spaced along the bolt circle.

The twelve holes on the mounting bolt circle let you rotate the unit in 30 degree increments to match the orientation of piping and wiring of the equipment.

Note: If you need a finer orientation or if you need to adjust the mounting position, locate the six holes on the inside of the mounting flange ring.

To allow for better orientation of equipment installations, the junction box bracket (located on the mounting flange) has been designed to mount during installation by utilizing two of the mounting locations along the bolt circle.

To mount the junction box assembly:

1. Mount the vacuum receiver using four (4) of the six (6) bolts.
2. Cut the temporary straps securing the junction box assembly to the mounting flange.
3. Orient the junction box assembly along the mounting bolt circle location. Stop when the location most closely matches the preferred installation orientation. The mounting holes for the junction box bracket must line up with two of the holes on the mounting bolt circle flange. Be careful of wiring on or around the unit.
4. Secure the junction box assembly with hardware through the remaining two (2) mounting flange holes. Properly tighten to secure the assembly to the flange.

Positioning and Spacing on the Demand Switch

The factory has pre-set the demand switch position for proper operation and, under most operating conditions, does not require adjustment.

The demand switch has two wires to provide for a normally open signal to the central controller (close to the load):

- A common (black) contact, and
- A closed (white) contact

The demand switch sends a signal to the central controller when the material discharge flapper is closed and the unit calls for material.

Most controllers utilize a closed contact to signal the conveying system controller that a material demand condition exists (using the black and white wires).

Note: The Demand/Level sensor is not designed to be connected to a load. Do not connect external devices to the sensor wires. This switch is designed for signal load only. Connecting the sensor to a load VOIDS YOUR WARRANTY!

If the switch is not providing a signal to the controller, check the following:

1. Check that the proper wire connections are made.
 - Secure the connections.
2. Make sure that the switch is not connected to any external load device.
 - Disconnect the load device, connect wiring to the system controller only.
3. Consult with ACS Service Engineers for proper switch/magnet spacing.

Once the vacuum receiver and Demand Switch have been properly oriented, complete the installation by performing the following:

1. Run a bead of silicone sealant around the mounting flange before seating the vacuum receiver. This makes a better seal.
2. Use nuts and screws to mount the hopper. Nuts and bolts can loosen, fall off, and damage process equipment.
3. Check across the mounting flange with a bubble level. A level installation is important for proper operation.
4. Properly ground all vacuum receivers.

Installing the Pickup Probe

Pickup probes (See Figure 20 on page 43 for an example) are used to empty gaylords or bulk material containers located beside the processing machine. A conveying system can use horizontal take-offs or vertical pickup probes (or a combination of the two) to supply material to the vacuum receivers. To ensure maximum conveying rates by your system, take the following into consideration:

- Locate the supply container near the vacuum receiver.
- Connect the pickup probe to a vacuum hopper material inlet tube with a minimum amount of tubing, bends, and flex hose.
- Secure the flex hose at the probe and the material inlet with hose clamps. Be sure to avoid loops and kinks, and install grounding wire around the outside of flex hose to prevent static built-up. Make sure you ground both ends of the grounding wire.
- Put the pickup probe in the material supply. The burrowing action of the probe provides a steady flow of material.
- To vary the convey rate, cover or open the vent holes on the pickup probe as needed with the inlet tube.
- If your material bridges frequently and triggers No-Convey alarm conditions, you should consider using a gaylord tilter or tilter/jogger to supply a steady stream of material to your conveying system.
- Container tilters are recommended for complete cleanout of gaylords.

Installing the Grinder Take-off Attachment

A grinder take-off attachment (See Figure 17 on page 41 for an example) is typically mounted horizontally through the side of a grinder or granulator bin or any other straight sided supply bin.

1. The take-off attachment is mounted through a hole cut close to the bottom of the bin to allow emptying as much material as possible.
2. Cut a hole smaller than the mounting plate.
3. Mount the take-off attachment with the mitered air inlet tube on top, and the straight material outlet on the bottom.
4. Mark and drill holes to match the mounting plate holes. Fasten tightly with sheet metal screws, bolts, or rivets.
5. Secure the mounting hardware with a removable thread locking adhesive, cotter pins, aircraft fasteners, etc. to prevent the hardware from vibrating loose and being conveyed into the processing machine.
6. You should attach grounded flex hose to the material outlet and the vacuum receiver with hose clamps. The other tube is the air inlet to supply make-up air to the bin. Avoid loops or kinks in the flex hose.

Installing and Adjusting the Take-off Compartment

Take-off compartments (TOCs) are installed under surge bins, silos, or other storage devices. TOCs are available in a single position complete cleanout style with a V-shaped bottom or a box type with one or more material takeoff positions (See Figure 18 on page 41 for an example.).

You can have several different size tubes for several different sized pump packages conveying a material from a central supply to several destinations.

Take-off compartments are typically pre-drilled for mounting and their outlets are sized to fit the pump package, material, and distance specified at the time of purchase. To optimize the use of your take-off compartment, provide for the following:

- Make sure that a three-foot (1 m) horizontal run is present prior to installing elbows.
- Install the TOC so the outlet tubes can head out unobstructed in the direction of the material destination.
- Use long radius bends on TOC outlets.
- Provide access for removing and cleaning TOC inlet air filters.
- Provide access for cleanout doors on TOCs.

Most TOCs have adjustable material inlet tubes to fine-tune the material to air ratio for optimal conveying rates. To adjust:

1. Loosen the set screw on the adjusting dial and turn the tube clockwise one third of the way from the 0 (zero) mark.
2. Turn ON the conveying system and start loading from the takeoff.

3. Rotate the dial until the material flows at a steady rate, then throttle it back a bit when surging or flooding occurs. System vacuum should be between 8" Hg (271 millibars) to 12" Hg (339 millibars) for best rates.
4. Lock the dial in place with the set screw when you have determined the best setting for a particular material. Make note of the setting and vacuum level for future reference.

Adjusting Fast Take-off (FCO) Compartments

When adjusting fast clean-out take-off compartments, make adjustments in small increments (especially in systems with long runs) to allow air flow to equalize throughout the system.

FCO-1.5M

In some applications, material flow characteristics may require a more defined air-to-material ratio. You can do this easily by covering one or more of the aeration holes located at the top of the inlet tube in FCO-1.5M fast clean-out take-off compartment models.

FCO-1.5MD

The FCO-1.5MD model fast take-off compartment has adjustable inner tubes fitted to the fixed outer tube. These adjustable inner tubes are locked down by a hold-down screw on the outer tube. Loosen this screw to adjust the inner tube.

When the adjustable inner tube is completely inside the material compartment and the indicator knob is in a vertical position, no material can be conveyed in the system. Adjust the tube by pulling it away and keeping the indicator knob vertical.

The maximum amount of material can convey when the reference hole on the adjustable inner tube is outside the edge of the outer tube. Vary the amount of material conveyed by rotating the inner adjustable tube.

To clean out material in the FCO-1.5MD model fast take-off compartment, unscrew the plug at the bottom.

Installing the Powder Check Adapter (Box Style; EVTO; FEVTO only)

The powder check adapter is usually factory-installed. When installing the powder check adapter, make sure you install it on the tube stub as shown below. Remove the filter on the take-off compartment and install the adapter using the four screws provided, then replace the filter. No other adjustments are required.

Figure 30: Typical Powder Check Adapter

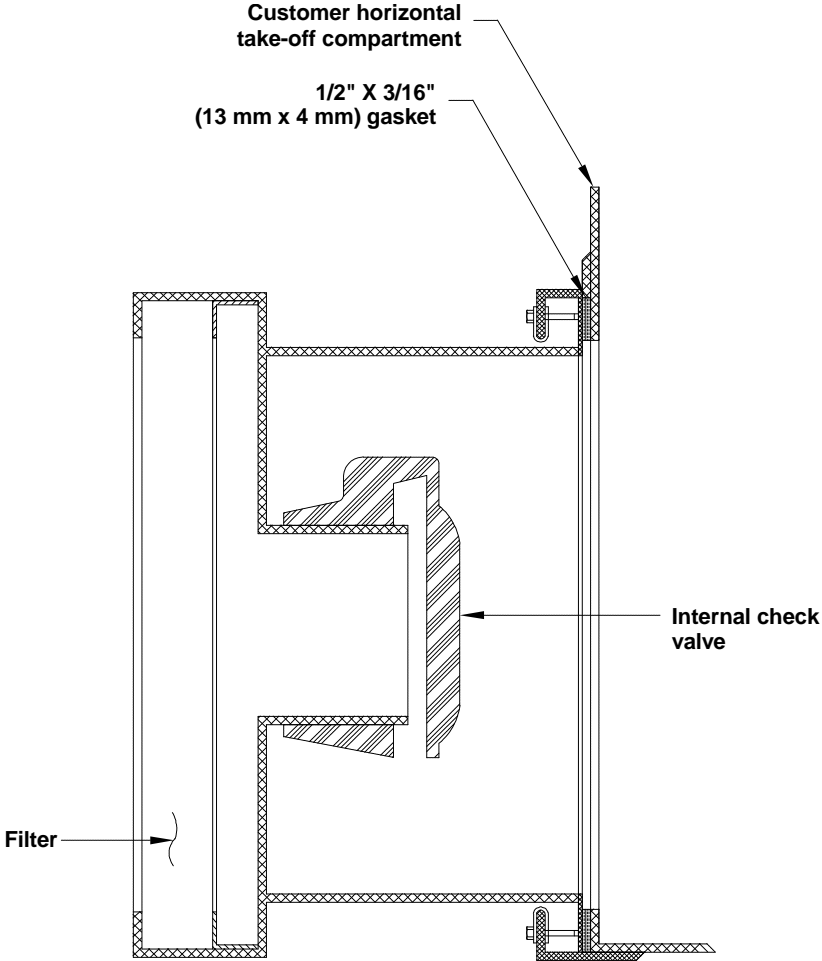

3-5 Compressed Air Connections

Making ACA Series Filter Chamber Compressed Air Connections

To provide proper filter bag cleaning, make sure that you regulate the compressed air supply to 80 psig (551.6 kPa/ 5.52 bars). Air consumption depends on frequency and length of cleaning air pulses into the filter bags. Higher pressures can shorten the life of filter bags; lower pressures cause poor filter bag cleaning.

Connect a 1/4" (approx. 6.3 mm) air line to the bottom of the solenoid valve air block. Make sure that the compressed air you use is clean, dry, and free of oil. In-line filters can handle small amounts of moisture; in-line desiccant filters or packed beds of granular absorbing polymer can remove oil mist and condensed oil.

Making Pump Compressed Air Connections

Connect the vacuum pump to a minimum of 60 psi to 80 psi (414 kPa to 552 kPa) source of clean, dry, lightly lubricated compressed air. Make the 1/8" NPT (3 mm) connection at the solenoid valve on the pump package.

Your compressed air supply piping should include:

1. A shutoff valve for ON/OFF control.
2. A pressure regulator with gauge.
3. An air filter/lubricator.

Connecting Vacuum Receivers with Atmospheric Valve Compressed Air Lines

See Figure 31 on the following page for an illustration of a typical atmospheric valve. Most conveying systems use atmospheric valves to direct system vacuum into the vacuum hoppers. You should be able to locate the atmospheric valve in one of three places:

- Installed on top of TF or VF Series vacuum receivers
- Installed in the vacuum header on SR Series vacuum receivers

Connect the atmospheric valve to 60 psi to 80 psi (414 kPa to 552 kPa) source of clean, dry, lightly lubricated compressed air.

Run a 3/8" (9 mm) branch line off the plant air main to supply the vacuum hoppers in your system. Install a 3/8" (9 mm) x 1/8" (3 mm) tee in the UP position near each hopper.

Connect compressed air to the normally closed port on the atmospheric valve solenoid valve with a 1/8" (approx. 3 mm) pipe nipple. Connect the common port to the atmospheric valve using 1/4" (6 mm) poly tube and connectors.

Figure 31: Solenoid Valve Location on Atmospheric Valve & Compressed Air Connections

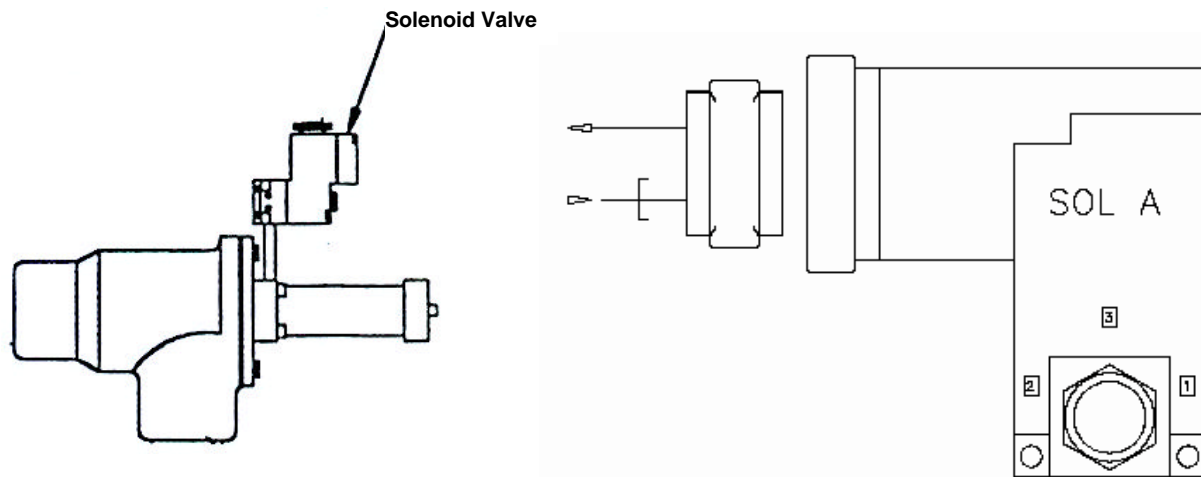

- (1) Normally Closed Port = Connect to Air Supply**
- (2) Common = Connect to Valve**
- (3) Normally Open = Exhaust Port**

Your $\frac{3}{8}$ " (9 mm) branch supply line should include:

1. A shutoff valve for ON/OFF control.
2. An air filter/pressure regulator with a gauge for pressure control.
3. Mini-lubricators located at each vacuum receiver.

Install a quick-disconnect fitting or a shutoff valve in the compressed air piping leading to the vacuum receiver atmospheric valve to speed receiver cover removal for cleanout or service.

Connecting Vacuum Receivers with Sequence-T Valve Compressed Air Lines

See Figure 32 on the following page for an illustration of a typical sequence-T valve. Critical dried resin systems sometimes require sequence-T valves to prevent drawing humid atmospheric air into the material supply. Sequence-T valves are usually installed in the vacuum header above the vacuum hoppers.

Note: *The sequencing valve is located in the cover on SR Series vacuum receivers if you selected the internal sequencing valve option.*

If mounted in the vacuum line, connect the sequence-T valve to a 60 psi to 80 psi (414 kPa to 552 kPa) source of clean, dry, lubricated compressed air.

Run a $\frac{3}{8}$ " (9 mm) branch line off the plant air main to the sequence T valves in your system. Install a $\frac{3}{8}$ " (9 mm) x $\frac{1}{8}$ " (3 mm) tee in the up position near each receiver.

Connect compressed air to the normally open port on top of the sequence-T valve solenoid valve with a $\frac{1}{8}$ " (approx. 3 mm) pipe nipple. Connect the common port to the sequence-T valve using $\frac{1}{4}$ " (6 mm) poly tube and connectors. See the following for more information.

Figure 32: Solenoid Valve Location on Sequence-T Valve & Compressed Air Connections

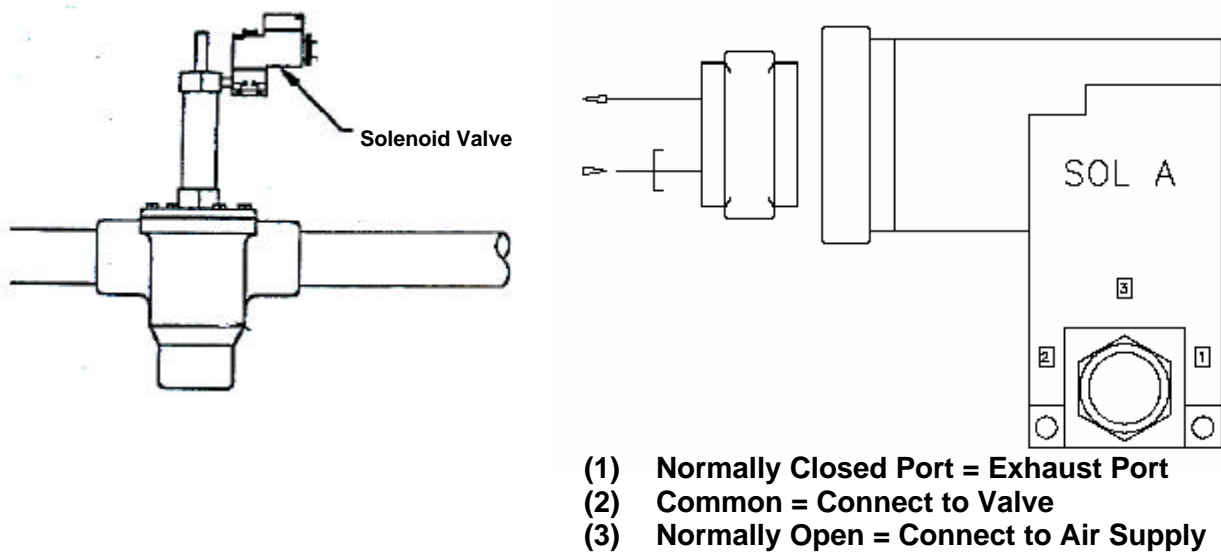

Your $\frac{3}{8}$ " (9 mm) branch supply line should include:

1. A shutoff valve for ON/OFF control.
2. An air filter/pressure regulator with a gauge for pressure control.
3. Mini-lubricators located at each vacuum receiver.

Running Remote Proportioning Valve or Proportioning Vacuum Receiver Compressed Air Lines

You must run compressed air to any proportioning valves in the system. Refer to the Proportioning Valve operating manual for detailed installation and operation information.

3-6 Electrical Connections

Refer to local electrical codes, the schematic, and connection diagrams supplied with this unit and the serial tag for wiring considerations. Run all wiring in conduit if codes require it. Label all wiring to make any future troubleshooting easier. Make all electrical connections *tight*.

Making ACA Series Filter Chamber Electrical Connections

WARNING! *Be safety conscious!*



High or low voltage can cause serious or fatal injury.

Installation must be performed by qualified personnel only!!

Always disconnect power source before attempting installation or repair.

Mount the control box in any convenient location free from excessive vibration where the temperature does not exceed 120°F (49°C). Power supply and solenoids are 115/1/60 for Models 91/93, 131/133, and 251/253 ACA filter chambers; choice of 115 VAC, 230 VAC or 24 VDC on 51/53 models. Locate the power supply terminal inside the control enclosure. Provide a hole as needed for the power supply cord and connect to L1, L2, and ground. See the electrical schematic wiring diagram supplied in your Customer Information Packet for more information.

Provide another hole in the control enclosure for wiring the solenoid valves on the filter chamber. Locate the terminal strip inside the control enclosure and connect the solenoid valve wiring in the order shown in the electrical schematic wiring diagram supplied in your Customer Information Packet. The order of wiring determines the sequence of the filter bag cleaning air pulses.

Making Pump Power Drop Wiring Connections

Pump packages are connected to a three-phase power supply. Bring properly sized power leads in conduit to the contacts in the junction box of each pump package in the system. Complete the pump wiring connections by performing the following:

- Install a properly-sized fused disconnect switch with lockout on the main lines to each vacuum pump package. This is recommended even for pumps with optional fused disconnects.
- Check the serial tag for voltage and amperage requirements. On 60 Hz units, voltage supplied to the unit must be within plus or minus ten percent ($\pm 10\%$) of the serial tag value; on 50 Hz units, within plus or minus five percent ($\pm 5\%$) of the serial tag value. Phase imbalance must be less than 2% in accordance with NEMA MG1-14.32.
- Ground the unit for operator safety and equipment protection.

Making Control Panel Power Drop Wiring Connections

Plug the controllers' power cord into a properly grounded, 3-slot, 115/1/60 VAC or 230/1/60 VAC receptacle as specified on the control panel serial tag and the enclosed controller Operation and Instruction manual. The control enclosure draws less than 5 amps during normal operation at 115/1/60 VAC.

Caution! *The manufacturer recommends that you protect PLC memory by providing the control panel with a dedicated circuit, a true earth ground, and a spike/surge protector.*

Connecting the Control Panel to Vacuum Receivers

Refer to the wiring connection drawings shown on the next page and to your conveying control panel's diagrams for general connections.

Note: *Each control panel is supplied with specific control schematics and a separate Operation and Instruction manual. To ensure proper conveying system operation, install the equipment according to the enclosed instructions.*

- Wire the Atmospheric/Sequence-T solenoid (SOL) valve to the terminal provided in the conveying system control panel enclosure.
- Wire the Bin Full/Hopper Full switch (LS/PRS) to the terminal provided in the conveying system control panel enclosure.
- On 115 VAC control voltage systems, run a common hot (115 VAC) wire and a common neutral wire from the controller to each vacuum receiver in the conveying system.
- On 24 VDC control voltage systems, run a common +24 VDC wire and a common 0 (zero) VDC wire from the controller to each vacuum receiver in the conveying system.
- On all systems, run two wires to each vacuum hopper: one each from the controller to the Bin-Full switch (LS) and to the Atmospheric/Sequence-T solenoid (SOL) valve.

Note: *The conveying system control panel is supplied with a terminal strip at the upper right corner for + positive and – negative wire connections.*

- *Be sure the solenoid and proximity switch(s) (if supplied) on vacuum receivers are the same voltage (24 VDC or 115 VAC) as the conveying system control panel control voltage. Consult the control panel serial tag and the solenoid valve nameplates.*
- *Wire size depends on control voltage, distance, number of vacuum receivers, and the number of wires in each raceway. Consult a qualified electrician.*
- *Properly ground each receiver to reduce static build-up generated by material conveying.*

Figure 33: Volume-Fill, Time-Fill, Vacuum Receiver Wiring Connections

115 VAC Control Circuit

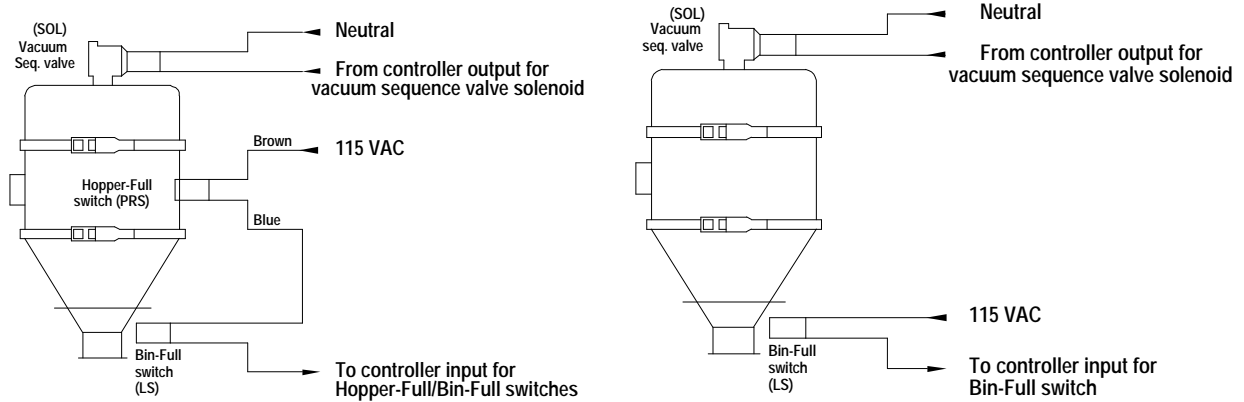

Vacuum Receiver - Volume fill

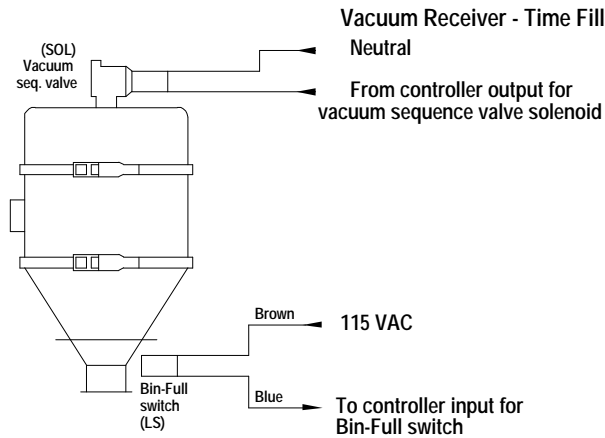

**Vacuum Receiver - Time Fill
(when using a proximity switch as a Bin-Full (Demand) switch)**

Figure 34: Volume-Fill, Time-Fill, Vacuum Receiver Wiring Connections

24 VDC Control Circuit

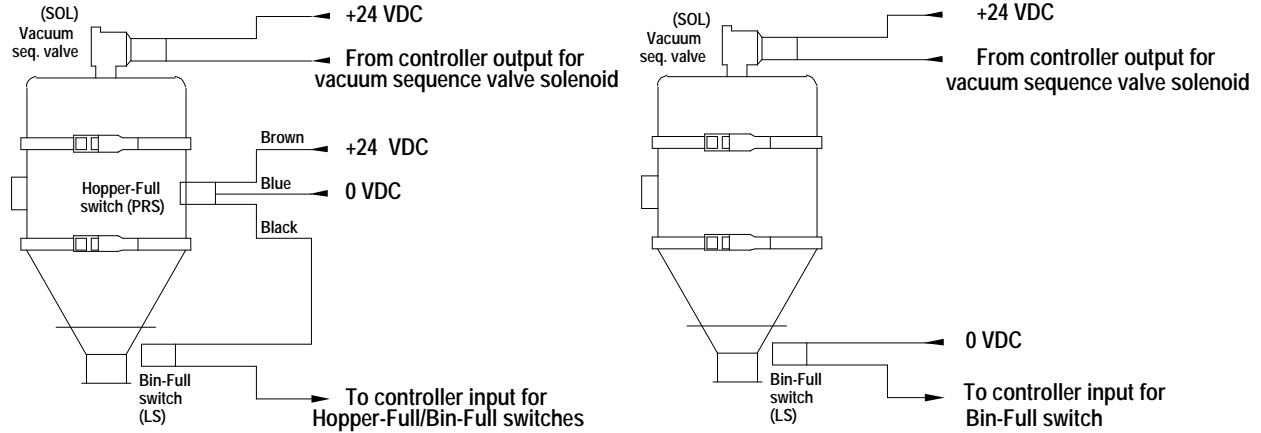

Vacuum Receiver - Volume Fill

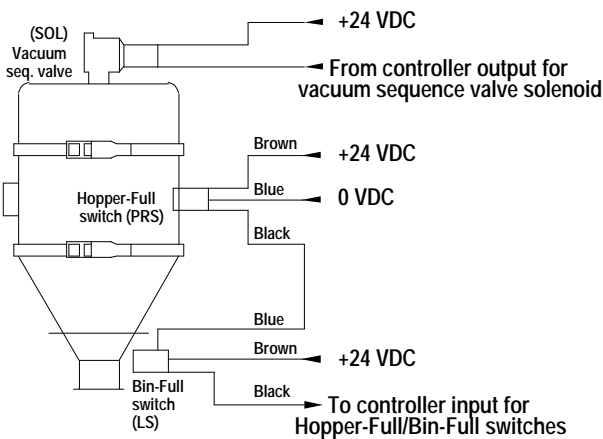

Vacuum Receiver - Volume Fill
(when using proximity switch as a Bin-Full switch)

Vacuum Receiver - Time Fill

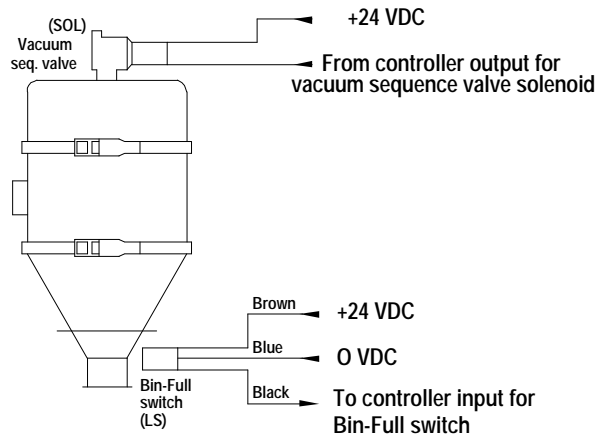

Vacuum Receiver - Time Fill
(when using proximity switch as a Bin-Full switch)

Installing Station Bypass Switches

The manufacturer recommends field-installing a station bypass switch (shown below) in a convenient location at each vacuum hopper in series with the flapper dump Bin Full (LS) switch. Check local codes.

Turning off this bypass switch simulates a full machine bin, cancels a No-Convey alarm, and takes the receiver out of the loading sequence until the switch is closed. This allows on-the-fly processing changes and cancels No-Convey alarms.

If the bypass switch is turned off while a hopper is filling, the switch simulates a full vacuum hopper and stops the conveying of material to that hopper *immediately*.

Figure 35: Recommended Field-Installed Optional Station Bypass Switch

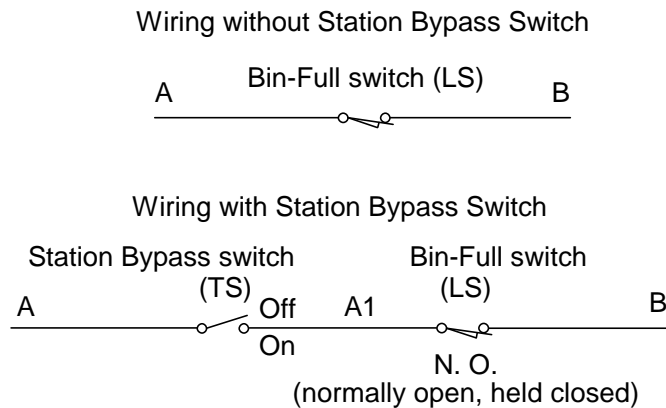

Connecting the Control Panel to the Pump Package

Note: Consult the specific schematics and Operation & Instruction manual supplied with your controller for your specific application.

- Wire the pump package motor starter coil (M) to the terminal provided in the conveying system control panel enclosure.
- Wire the pump package vacuum relief valve solenoid (SOL A) to the terminal provided in the conveying system control panel enclosure.
- Wire the pump package high vacuum switch (VS) to the terminal located in the conveying system control panel enclosure.
- On SPDB pumps, wire the pump package blowback solenoid (SOL B) to the terminal located in the conveying system control panel enclosure.
- On 115 VAC control voltage systems, run a common hot 115 VAC wire and a common neutral wire from the controller to the pump package in the conveying system.
- On 24 VDC control voltage systems, run a common +24 VDC wire and a common 0 (zero) VDC wire from the controller to the pump package in the conveying system.

Note: Make sure that the pump motor starter, the vacuum relief valve solenoid, and the blowback solenoid (if supplied) are the same voltage (24 VDC or 115 VAC) as the conveying system control panel control voltage. Consult the control panel serial tag and the pump package serial tag.
Wire size depends on control voltage, distance, number of vacuum hoppers, and the number of wires in each raceway. Consult a qualified electrician.

Figure 36: Typical SPD Series Junction Box Wiring Diagram

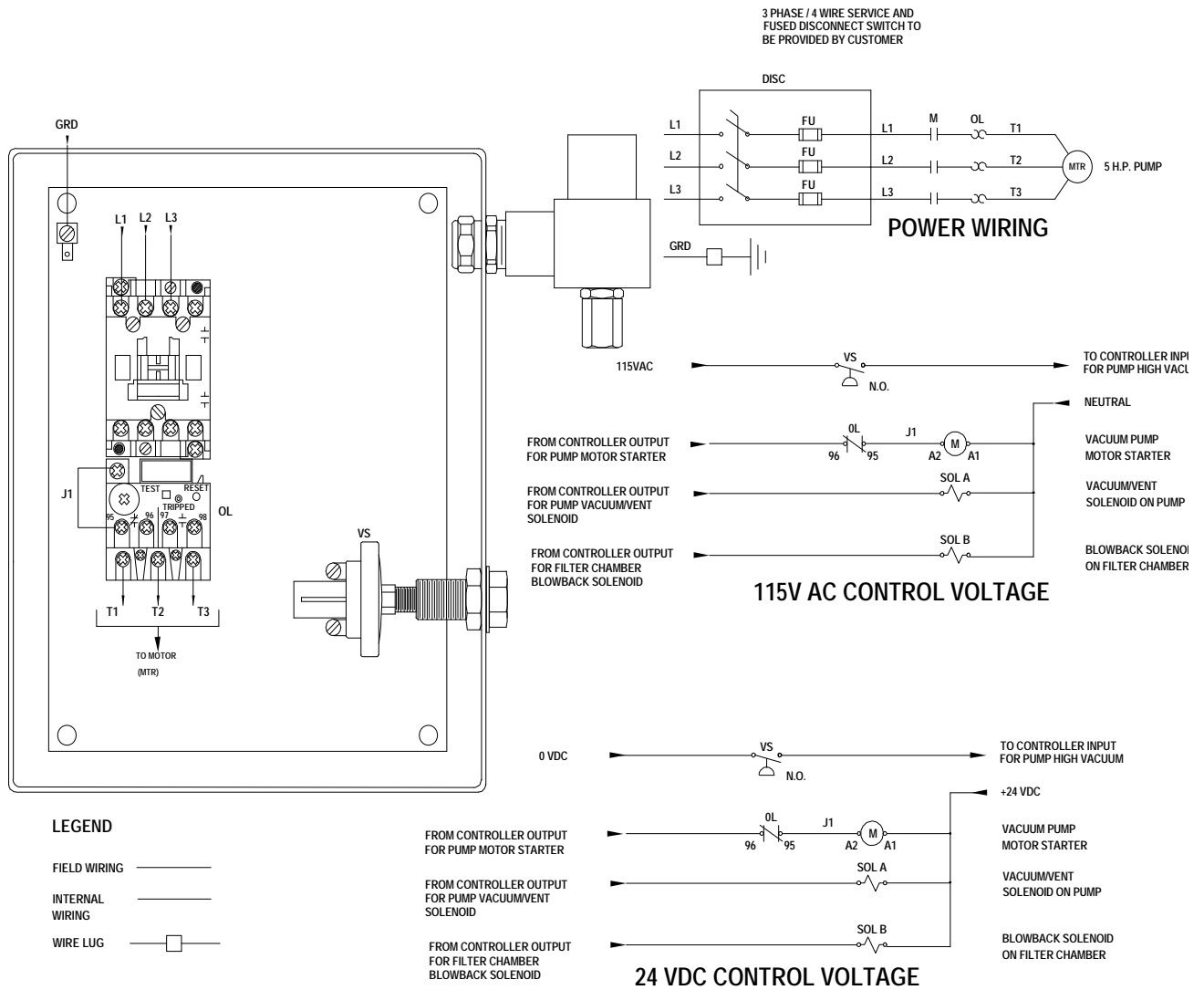

Note: This information is shown for reference only. Refer to the electrical Schematics that were supplied with your equipment and controls for specific wiring information.

Figure 37: Typical SPD Series Junction Box with Fused Disconnect Wiring Diagram

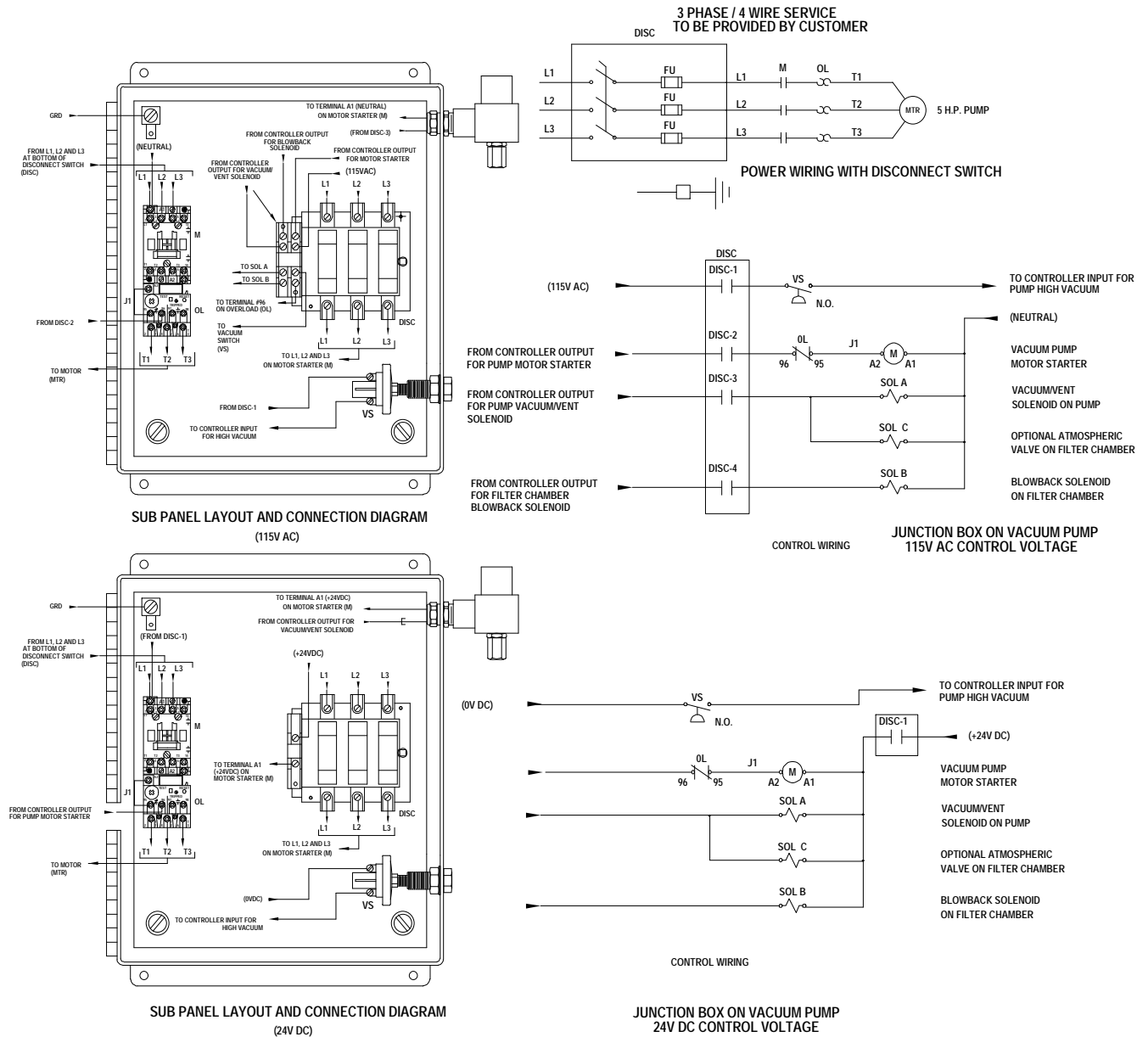

Note: This information is shown for reference only. Refer to the electrical Schematics that were supplied with your equipment and controls for specific wiring information.

Figure 38: Typical SPDB 5-15 Series Junction Box Wiring Diagram

**SUB PANEL LAYOUT AND CONNECTION DIAGRAM
(24V DC)**

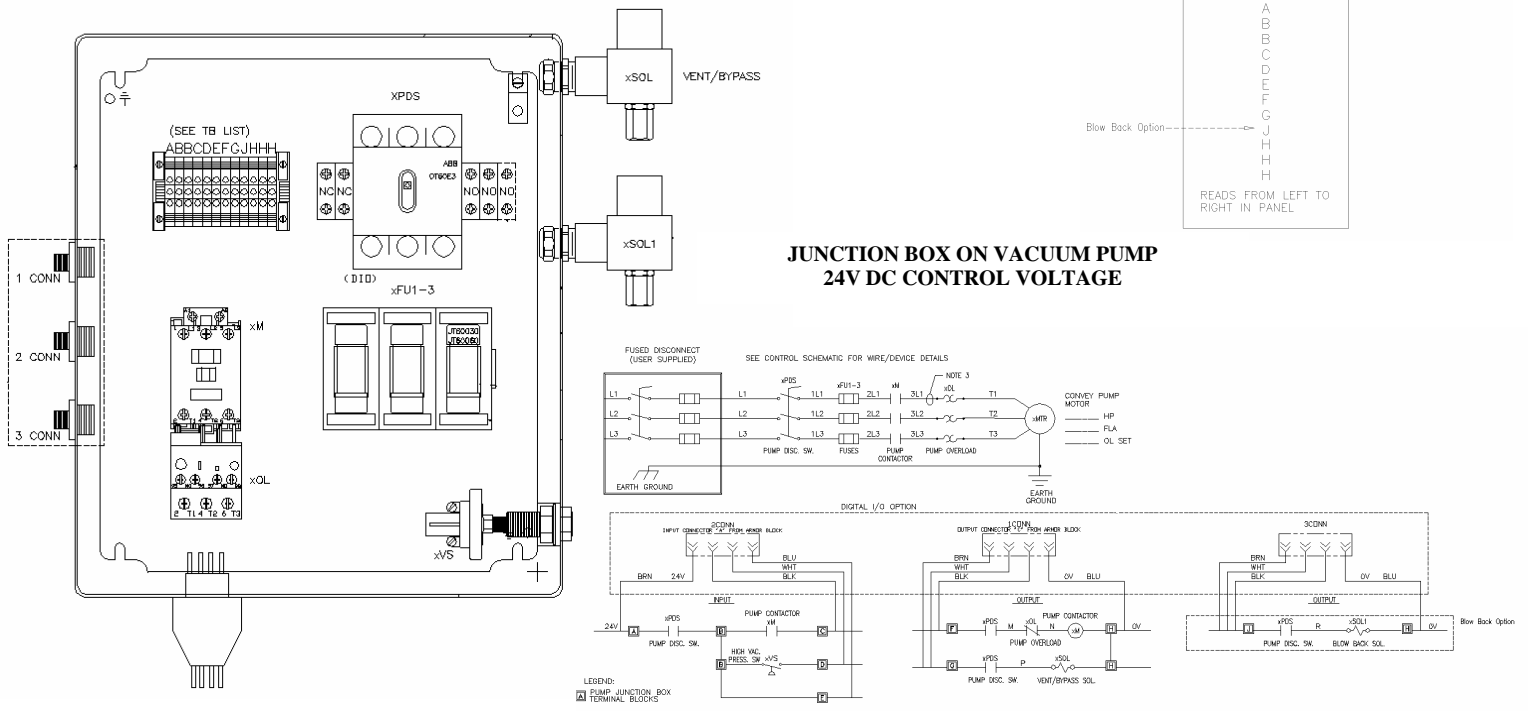

**SUB PANEL LAYOUT AND CONNECTION DIAGRAM
(115V AC)**

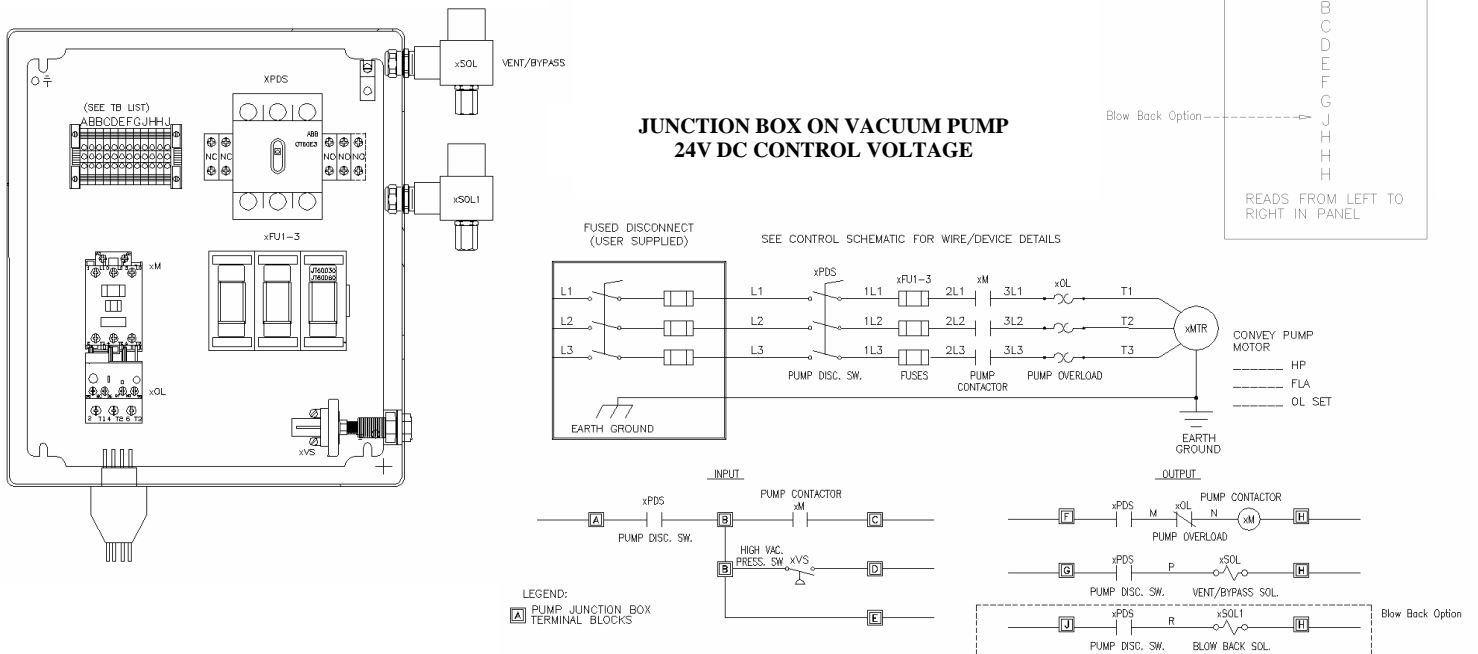

Note: This information is shown for reference only. Refer to the electrical Schematics that were supplied with your equipment and controls for specific wiring information.

Figure 39: Typical SPDB 25, 30 Series Junction Box Wiring Diagram

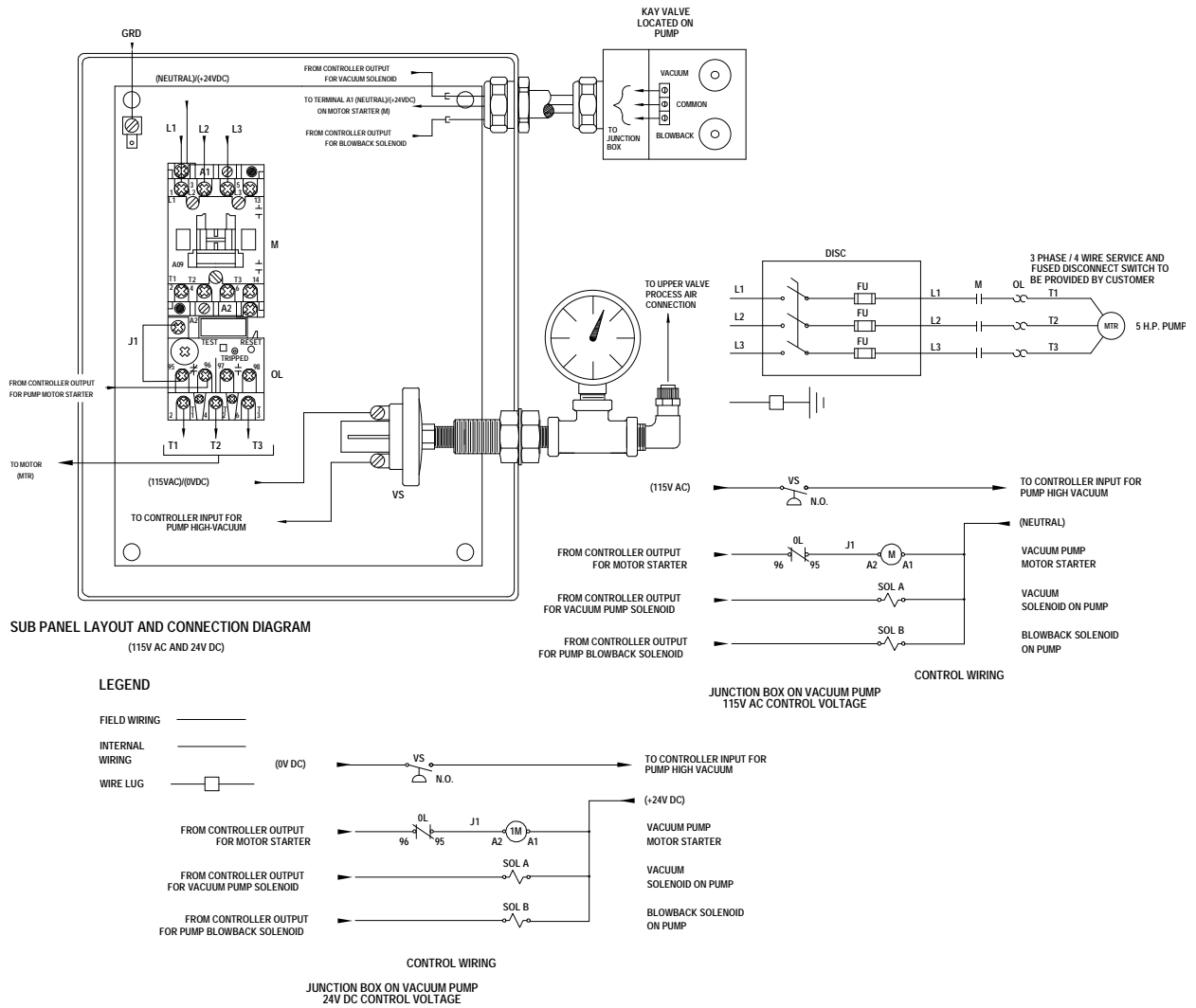

Note: *This information is shown for reference only. Refer to the electrical Schematics that were supplied with your equipment and controls for specific wiring information.*

Figure 40: Typical SPDB 25, 30 Series Junction Box with Fused Disconnect Wiring Diagram

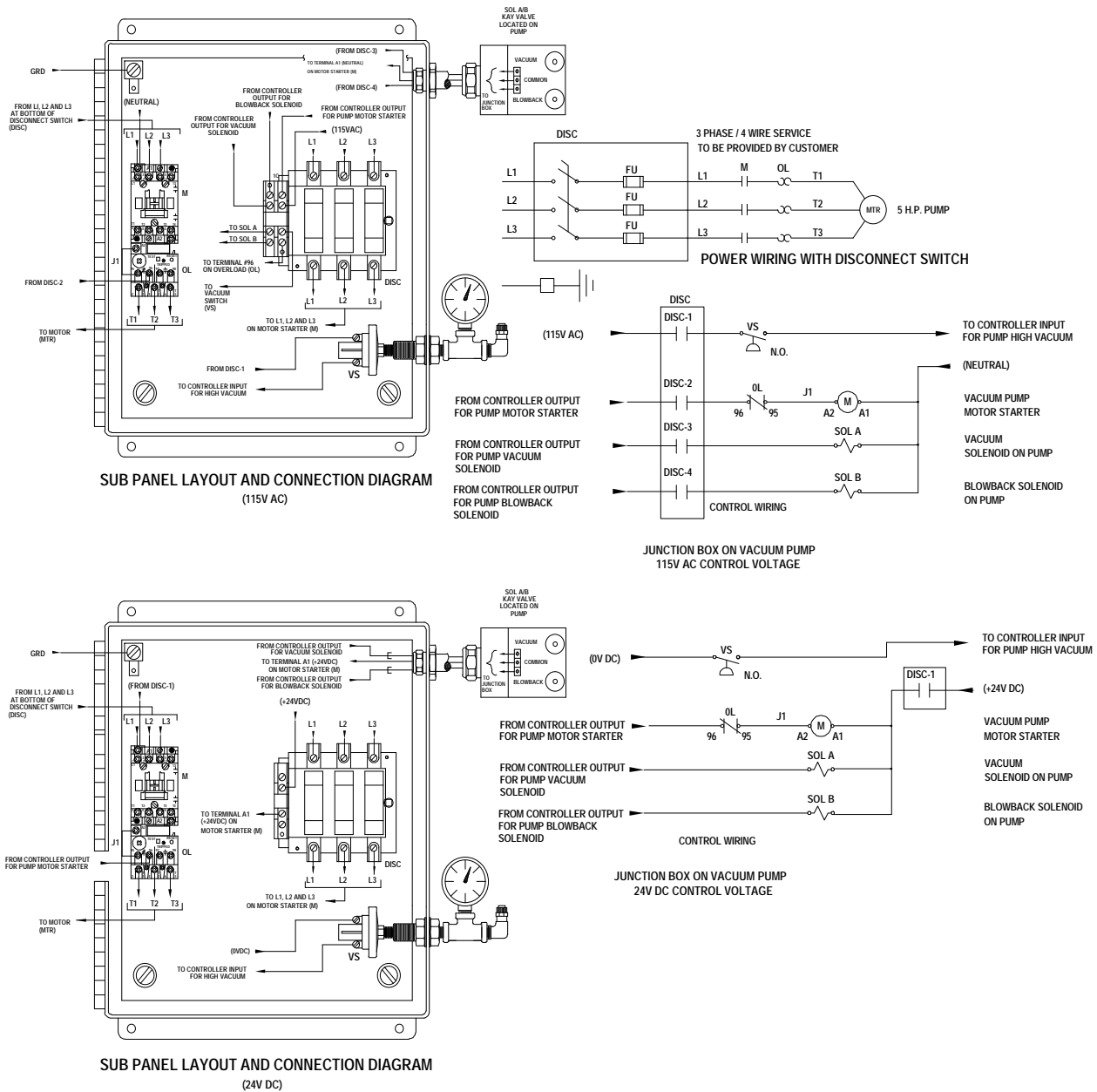

Note: This information is shown for reference only. Refer to the electrical Schematics that were supplied with your equipment and controls for specific wiring information.

3-7 Initial Start-up

Making Startup Checks

Before operating the conveying system, check these details:

1. All components in the system must be installed securely and prepared for operation. Refer to the instructions supplied with auxiliary equipment for specific checks.
2. Couplers, fittings, attachments, and flexible lines must be attached securely and be vacuum-tight.
3. Electrical and compressed air connections to the pump package, vacuum hoppers, and filter chambers must be complete, safe, and conform to code.
4. The pump package blower gearbox must be filled with oil as specified in the manufacturer's instructions included in the customer information package.

Caution! ***Do not overfill the blower gearbox with oil; too much oil damages the blower.***



5. If not done already, remove the plastic plug from the silencer air outlet.

WARNING! ***Keep hands away from the open air inlet to avoid injury!***

6. Do not allow any loose parts, tools, or foreign materials in or near the unit and other system components.
7. Check for proper motor rotation, as indicated by an arrow on the pump package motor. Bump-start the pump package with the compressed air disconnected just long enough to verify proper rotation direction.

Note: ***To change motor rotation:***

- a. Disconnect power at the external disconnect.
 - b. Switch any two incoming power leads on the main power supply.
8. Make sure that filter chamber housings have no leaks; check stretcher clamps for tightness.

Adjusting Sight Glass Proximity Sensor Sensitivity

You can adjust the sensitivity of the material level proximity sensor in the sight glass. The factory setting usually is correct for most applications. The sensor is factory-installed to the frame; however, you should install the sensor at the material level height you want.

When adjusting, fill the glass and verify that the sensor detects your material. The LED on the switch *goes out* when it detects material.

- For increased sensitivity, turn the potentiometer clockwise.
- For decreased sensitivity, turn the potentiometer counterclockwise.
- Consult proximity switch instructions if necessary or call Service Department.

Adjusting Air Pulse Duration: All Models

Locate the on-time potentiometer inside the control enclosure on the circuit board. With the unit operating, turn the potentiometer counterclockwise to shorten the air pulse duration; *turn clockwise to lengthen* the air pulse.

ACA Series Filter Chamber Pre-Operation Checklist

Check the following before you operate ACA Series filter chambers:

1. Make sure all mechanical installations are complete.
2. Make sure all electrical and compressed air connections are complete and correct.
3. Make sure that no leaks are present in the filter chamber housing. Check stretcher clamps for tightness.

Adjusting Time Between Air Pulses on ACA Filters

Models 91/93, 151/153, and 251/253

The time between cleaning air pulses requires adjusting to match up with dusting characteristics of the material being conveyed. If more dusting occurs, then more frequent compressed air pulses are required to clean filter bags.

Locate the off-time control potentiometer inside the control enclosure and adjust from 0- to 30-second intervals between air pulses to match material conveying characteristics.

Adjusting the Number of Air Pulses

Model 51/53 Low Boy

Locate the DIP switch inside the blowback control box. Set the DIP switch to the number of pulses you want from 1 to 16, using the DIP switch settings shown in the following figure. The diagram is also shown on the blowback control box electrical schematic located in your Customer Service Packet.

Figure 41: ACA Series Model 50 Blowback DIP Switch Settings

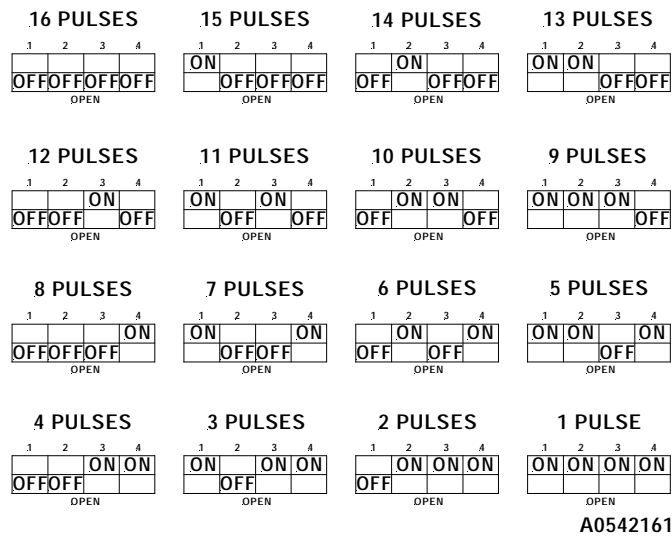

Starting ACA Series Filter Chamber Units

With all adjustments complete, turn on clean, dry, oil-free compressed air and regulate to 60 psi to 80 psi (414 kPa to 552 kPa). Turn the power on/off switch to ON; the unit then automatically self-cleans the filter bags. An indicator light on the control box for Model 91/93, 151/153, and 251/253 ACA filter chambers illuminates each time a compressed air pulse is directed into a filter bag.

Note: *If for any reason the power is turned off, wait at least three (3) seconds to reset.*

During initial startup, you'll note some dusting occurring at the clean air exhaust. This condition is normal with new filter bags until the exterior surfaces of the bags become evenly coated with dust particles, which prevents fine material from passing through the filter bag pores. This dusting condition should stop after the first several hours of operation.

Adjusting Proximity Sensor Sensitivity

Models Equipped with Volume-Fill Switch Only

A proximity switch mounted in VF, SSR and SSR vacuum receivers detects when the vacuum receiver has been filled during a conveying sequence, telling the conveying system control to move on to the next on-line vacuum receiver in the sequence. This speeds the conveying cycle and shuts the pump down promptly to conserve electricity if all the bins being loaded are full.

The sensitivity of the vacuum receiver material level sensor can be adjusted. The factory setting is correct for most applications. The sensor is mounted through the wall of the vacuum receiver.

Note: *The adjusting potentiometer is located beneath a plastic cover screw near the sensor LED indicator. Remove the protective cover screw before making adjustments and replace it when finished.*

Note: *Before adjusting the Receiver-Full sensor, make sure that the Bin Full sensor is in the closed position.*

When adjusting, fill a vacuum hopper to see if the switch detects your material. The LED on the switch *goes out* when it detects material.

- For increased sensitivity, turn the potentiometer clockwise.
- For decreased sensitivity, turn the potentiometer counterclockwise.
- Consult proximity switch instructions if necessary or call Service Department.

Chapter 4: Operation

4-1 Start-up

Starting ACA Series Filter Chamber Units

Turn on clean, dry, oil-free compressed air and regulate to 60 psi to 80 psi (414 kPa to 552 kPa). Turn the power on/off switch to ON; the unit then automatically self-cleans the filter bags. An indicator light on the control box for Model 91/93, 151/153, and 251/253 ACA filter chambers illuminates each time a compressed air pulse is directed into a filter bag.

Note: If for any reason the power is turned off, wait at least three (3) seconds to reset.

4-2 Operation Procedures

When you activate the controller, the system energizes and initiates the conveying cycle. The following components energize:

- The vacuum pump motor starter.
- The vacuum pump vent valve.
- The sequencing valve above the first on-line vacuum receiver that requires material.

The vacuum pump draws vacuum to that receiver. When the receiver is full or the time interval elapses, the controller then signals the atmospheric valve above the next on-line receiver requiring material to energize, allowing material to convey to that receiver. The conveying sequence continues to the last on-line vacuum receiver requiring material.

When the time interval for the last receiver elapses or the receiver is full, a new conveying cycle begins at the first on-line vacuum receiver requiring material.

Note: The sequence of events listed above is a generalized description of what occurs when a controller is activated. Consult your specific controller manual for an accurate depiction of these events.

Vacuum Switch (VS) Operation

A high vacuum switch is mounted inside a pump package junction box. It is preset to close at 14" Hg (475 millibars) and is not adjustable. The vacuum switch protects the pump package from motor damage caused by high amperage draw and strain on the blower.

Pumps typically draw a vacuum of less than 5" Hg (170 millibars) only when air is pulled into the system and 8" to 12" Hg (271 to 339 millibars) while conveying.

If system vacuum should reach 14" Hg (475 millibars), the high vacuum switch closes. The pump package tries to clear the line for three seconds, then moves to the next on-line vacuum receiver. The normal conveying cycle continues. If high vacuum keeps occurring, the pump continues with attempts to clear the line.

See your specific controller manual for additional operation information.

High Vacuum Relief Regulator Operation

A factory-set pressure regulator is installed on the pump package vent valve as a mechanical back-up safety feature. It protects the pump motor from damage during high vacuum conditions if an undetected failure of the vacuum switch should occur. The regulator is set to limit system vacuum to 15" Hg (475 millibars) by allowing the vent valve plunger to shift and vent the pump. SPC vacuum relief is set at lower levels based on vacuum pump performance curves.

Note: *Do not adjust the pressure regulator. Adjusting the pressure regulator voids your warranty.*

See Figure 36 on page 71 for additional operation information.

4-3 Shut-down

To deactivate the conveying system:

1. Turn the disconnect switch at each pump or component to OFF. This will take each pump or component offline.
2. Turn off the compressed air supply to the system.

Note: *Consult your specific controller operation and instruction manual for specific shut-down information for your conveying system.*

Chapter 5: Maintenance

5-1 Preventative Maintenance Schedule

The checklist below contains a list of items which should be inspected and/or replaced to keep the mechanical components of your conveying system operating at peak efficiency. Perform each inspection at the regular intervals listed below.

System model #						Serial #							
Every week	Date/By	Date/By	Date/By	Date/By	Date/By	Date/By	Date/By	Date/By	Date/By	Date/By	Date/By	Date/By	Date/By
Inspect all filters for wear, replace/clean if dirty or worn.													
Check to make sure that all hose connections are air tight.													

Every month	Jan	Feb	Mar	Apr	May	Jun	Jul	Aug	Sep	Oct	Nov	Dec
Lock out electrical power and inspect electrical wiring for integrity.												
Check demand sensor.												
Inspect gaskets at hoppers.												
Inspect belt(s).												
Oil & grease (lubricate) components												

- Photocopy this page for your maintenance records -

5-2 Preventative Maintenance

Maintaining Pump Packages

Pump packages need periodic maintenance to provide long dependable service. Check these elements regularly:

- Maintain a proper oil level in the blower gearbox. The manufacturer's brochure (packed with the pump package) recommends oils, and lists instructions for checking the oil level. See Oil Capacities chart on following page.
- Pack blower bearings with high temperature ball bearing grease and change the oil to the manufacturer's recommendations.
- V-belts are sized for maximum life with the pump package blower/motor combination. Inspect periodically for proper tension, and replace when worn.

Note: *V-belts stretch when new. Check belt tension after you have run them in. At proper belt tension, the belt should deflect downward $1/64$ " for every one inch span (1 mm every 6.4 cm) from sheave to sheave.*

- Keep the pump package area clear of any debris that could be drawn through the vent valve and into the blower while the pump package is idling.
- Torque the motor and blower sheave bolts to 72 ft.-lbs. (98 N•m).
- Check the moisture traps in the compressed air lines. Drain as needed.
- Check the compressed air lubricator(s) for flow rate and level. **Use only 1 or 2 drops of oil per day** when lubricating. Adjust and fill as necessary.
- Inspect the silencer periodically for contamination. Silencer fouling indicates poor filter maintenance at the vacuum hopper or filter chamber. Fines may also be drawn into the silencer through the pump package vent valve during the dump cycle from poor housekeeping near the pump package.

Caution! *Make sure you replace a contaminated silencer immediately to avoid blower damage and possible fire hazard.*

- Standard pump package TEFC motors do *not* require lubrication or oiling. Optional motors may have different requirements. Refer to the motor manufacturer's specification sheet in your Customer Information Packet.
- Keep the control panel and pump package junction boxes securely closed to prevent component contamination.
- Inspect air cylinders and plungers for proper operation.
- Verify that all safety components/circuits are in full operational conditions.

Oil Capacities-SPD Only*

Model	Part No.	Frame	Vertical ¹		Horizontal ¹	
			GE (OZ)	DE (OZ)	GE (OZ)	DE (OZ)
URAI-J 33	A0571182	3" DSL	8.5	4	16	6.5
URAI-J 45	A0571183	4" DSL	12.7	5.5	22.8	10.8

¹GE= GEAR END, DE = DRIVE END

Suggested Lubricants:

Synthetic Oil

Size of container	Part #
Quart	214.00002.00
Gallon	A0573982
Case	214.00004.00

****SPD style vacuum blowers require a synthetic blend of lubricant for proper operation. Using other types of lubricant may void all warranties.***

Note: For more information, refer to the blower manufacturers instruction manual.

Maintaining Filter Chambers

SFC Filter Chambers

SFC filter chamber maintenance is much easier if you use vinyl flex hose for making the final connection to the cover. See Figure 55 on page 118 for a complete parts list.

To check the filter element:

1. Unlatch the clamp that secures the cover assembly.
2. Lift off the cover and look for element fouling or wear:
 - If the filter is worn, replace with P/N A0571262 (SFC-S), P/N A0547008 (SFC225), or P/N A0547007 (SFC1000).
 - If the filter is lightly soiled, remove the filter and clean with compressed air. Blow it out from the inside.
3. To remove the filter:
 - a. Note the orientation of the components.
 - b. Unscrew the retaining cover.
4. Wipe down the gasket and filter retainer/SFC cover mating surfaces to ensure a good seal.
5. Blow out the cartridge filter with compressed air. Blow from the inside out.
6. Re-install the filter and filter retainer. Do not over tighten the retainer. A snug fit is required for a proper seal.
7. Secure the cover assembly with the clamp.
 - Periodically inspect the flapper assembly gasket and disk for signs of wear. A good vacuum seal is important for proper operation.
 - Periodically inspect the flapper dump assembly for proper operation. The flapper should swing freely.

Note: *The counterbalance should be adjusted so the flapper remains open from $3/16$ " (4 mm) to $1/4$ " (6 mm) when not under vacuum.*

Inspecting ACA Series Filter Chamber Filter Bags

Schedule regular filter bag inspections to maintain the operational efficiency of the filter chamber. Make sure that schedules coincide with materials that are being conveyed. Dusty materials require more frequent filter bag examinations.

1. Turn off compressed air and disconnect the electrical power supply.
2. Remove the stretcher clamp just below the externally mounted solenoid valves. Be careful to avoid damaging the gasket between tank sections.
3. Lift off the upper tank section with accumulator, blowpipes, and filter bag rack.
4. Inspect the filter bags for dust caking, dampness, or oil deposits. Any or all of these symptoms are indications of moisture or condensed oil in the compressed air supply.

5. Check compressed air supply in-line filters and clean or replace as needed. If moisture is condensing inside the filter chamber, you may need to insulate the chamber and the piping leading to the filter. This action should keep the surface moisture above the dew point and prevent condensation on filter bags.
6. Do not attempt to wash or reuse soiled ACA filter bags. If they are clogged, replace them with new filter bags. Contact the Parts Department for more information on replacement filter bags.
7. Inspect the filter bags for wear. Thinning bags may not stop fine dust when flexed with compressed air, or dust can escape into the clean air tank section and contaminate conveying air. Replace with new filter bags as needed.

Note: *When re-installing ACA Series filter bags, make sure that the bag is turned inside out, with the glazed surface facing outward.*

8. Carefully slip the bag over the bag cage. Position the filter bag all the way onto the bag cage, and place a clamp around the bag near the top of the bag rack plate. Tighten the clamp.

Note: *Improperly installed clamps cause a poor dust seal. Dusting in the clean air exhaust is a normal condition after installing new filter bags, and should stop after the first several hours of operation.*

9. Replace the upper tank section, with the gasket properly seated between upper and lower sections. Make sure the filter bags are hanging straight down and that the bags do not touch each other or the inside walls of the filter chamber. This action prevents excessive bag wear when compressed air pulses enter the bags.
10. Replace and tighten the stretch clamp.

Maintaining SPDB Series Vacuum Power Unit Non-Reversing Valves

Upper and lower non-reversing valves require periodic service to keep SPDB Series vacuum power units operating at peak efficiency. Contact the Parts Department for information on valve service kits and customer-recommended parts.

Maintaining Upper Valves -5 to 15 HP (3.73-11.19 kW) SPDB Units

(See Valve Assembly Drawings and Spare Parts Lists in Figures 47-48)

Removing Upper Valves

1. Turn off and lock out the power switch for the vacuum power unit. Disconnect and lock out the power main to the unit; make sure to follow applicable safety regulations.
2. Turn off compressed air. Disconnect the compressed air line running to the pressure relief regulator.
3. Loosen the hose clamps that connect the upper valve to the incoming vacuum line and lower valve, and slide the hose back.
4. Loosen the set screws that secure the valve to the blower inlet.
5. Remove the valve from the power unit.

Disassembling Upper Valves

1. Remove the two (2) socket cap screws from the upper cap, and remove the upper cap.
2. Remove the six (6) socket cap screws from the end plate. Separate the end plate and air cylinder from the machined body.
3. Remove the cotter pin from the plunger. Unscrew the plunger from the air cylinder shaft.
4. Remove the four (4) socket cap screws holding the air cylinder to the end plate. Separate the cylinder and the end plate.

Servicing and Reassembling Upper Valves

1. Clamp the air cylinder in a vise and unscrew the end cap. Using parts from the valve service kit, replace the seals in the air cylinder. Screw the end cap back on.
2. Secure the air cylinder to the end plate using the four (4) socket cap screws.
3. Screw a new plunger on the air cylinder shaft; secure it with the cotter pin.
4. Place a new gasket on the end plate; secure the end plate.
5. Reattach the upper cap to the air cylinder using two (2) socket cap screws.

Reinstalling Upper Valves

1. Replace the O-rings in the machined body.
2. Position the valve on the blower inlet, making sure the valve seats properly. Tighten the set screws that secure the valve to the blower inlet.
3. Reconnect the valve inlet to the incoming vacuum line and the lower valve with the hose. Tighten the clamps.
4. Reconnect the compressed air line to the vacuum relief regulator.

Maintaining Lower Valves - 5 to 15 HP (3.73-11.19 kW) SPDB Units

Removing Lower Valves

1. Turn off and lock out the power switch for the vacuum power unit. Disconnect and lock out the power main to the unit; make sure to follow applicable safety regulations.
2. Turn off compressed air. Disconnect the copper compressed air line to the lower valve at the lower valve body.
3. Loosen the hose clamps that connect the valve to the T-Y tube, and slide the hose back. On units with optional sound enclosures, loosen the hose clamps between the discharge silencer and the U-bend.
4. Remove the screws holding the discharge silencer to the base of the vacuum power unit, and take off the discharge silencer. On units with optional sound enclosures, remove the screws securing the U-bend to the base, and pull the silencer out of the body of the lower valve.
5. Loosen the set screws holding the lower valve to the blower outlet, and remove the valve from the power unit.

Disassembling Lower Valves

1. Remove the pipe nipple and pipe coupler from the lower cap.
2. Remove the two (2) socket cap screws from the lower cap.
3. Remove the lower cap from the machined body.
4. Remove the six (6) socket cap screws from the end plate. Separate the end plate from the machined body.
5. Remove the cotter pin from the plunger. Unscrew the plunger from the air cylinder shaft.
6. Remove the four (4) socket cap screws holding the air cylinder to the end plate.

Servicing and Reassembling Lower Valves

1. Clamp the air cylinder in a vise and unscrew the end cap. Using parts from the valve service kit, replace the seals in the air cylinder. Screw the end cap back on.
2. Secure the air cylinder to the end plate using the four (4) socket cap screws.
3. Screw a new plunger on the air cylinder shaft; secure it with the cotter pin.
4. Place a new gasket on the end plate; secure the end plate to the machined body using six (6) socket cap screws.
5. Fasten the lower cap to the air cylinder using two (2) socket cap screws, a new gasket, and a new O-ring.
6. Screw the pipe nipple and coupler back into place.

Reinstalling Lower Valves

1. Replace the O-rings in the machined body.
2. Position the valve on the vacuum power unit. Tighten the set screws that secure the valve to the blower outlet.
3. Reconnect the valve to the T-Y tube by sliding the radiator hose back into place. Tighten the hose clamps.
4. Reconnect the copper compressed air tube to the fitting on the lower valve.
5. Push the discharge silencer into the valve body, and secure it with the screws. On units with optional sound enclosures, push the short silencer into the valve body, reinstall the U-bend, and secure both ends with the radiator hose and hose clamps.

Maintaining Upper Valves - 25 and 30 HP (18.65-22.38 kW) SPDB Units

(See Valve Assembly Drawings and Spare Parts Lists in Figures 50-51 on Pages 112-113)

Removing Upper Valves

1. Turn off and lock out the power switch for the vacuum power unit. Disconnect and lock out the power main to the unit; make sure to follow applicable safety regulations.
2. Turn off compressed air. Disconnect the compressed air line running to the pressure relief regulator on the upper valve.
3. Loosen the set screws securing the inlet filter, and remove the filter.
4. Loosen the hose clamps that connect the upper valve to the T-Y tube, and slide the hose back.
5. Loosen the set screws that secure the valve to the blower inlet.
6. Remove the valve from the power unit.

Disassembling Upper Valves

1. Remove the pipe coupler and the pipe nipple from the valve.
2. Remove the two (2) socket cap screws from the upper cap, and remove the upper cap from the valve body.
3. Remove the six (6) socket cap screws from the end plate. Separate the end plate from the valve body.
4. Remove the locknut from the air cylinder shaft.
5. Remove the two (2) plunger support discs and the plunger from the air cylinder shaft.
6. Remove the four (4) socket cap screws holding the air cylinder to the end plate. Separate the cylinder and the end plate.

Servicing and Reassembling Upper Valves

1. Clamp the air cylinder in a vise and unscrew the end cap. Using parts from the valve service kit, replace the seals in the air cylinder, and screw the end cap back on.
2. Fasten the air cylinder to the end plate using the four (4) socket cap screws.
3. Place the plunger support discs and a new plunger on the air cylinder shaft.
4. Thread the locknut back on the air cylinder shaft.
5. Reconnect the end plate to the valve body using six (6) socket cap screws and a new gasket.
6. Reconnect the upper cap to the air cylinder using two (2) socket cap screws.
7. Reconnect the pipe coupler and pipe nipple to the valve.

Reinstalling Upper Valves

1. Replace the O-ring in the valve body.
2. Position the valve on the power unit, making sure the valve seats properly. Tighten the set screws that secure the valve to the blower inlet.
3. Reconnect the valve inlet to the incoming vacuum line using the radiator hose. Tighten the clamps.
4. Reconnect the compressed air line to the vacuum relief regulator.
5. Secure the inlet filter to the valve, and tighten the set screws.

Maintaining Lower Valves-25 and 30 HP (18.65-22.38 kW) SPDB Units

Removing Lower Valves

1. Turn off and lock out the power switch for the vacuum power unit. Disconnect and lock out the power main to the unit; make sure to follow applicable safety regulations.
2. Turn off compressed air. Disconnect the copper compressed air line to the lower valve at the lower valve body.
3. Loosen the hose clamps that connect the valve to the T-Y tube, and slide the hose back.
4. Remove discharge silencers. Unscrew the vertical silencer and unbolt the bracket holding the silencer under the unit. Pull the silencer out of the valve body.
5. Loosen the set screws holding the lower valve to the blower outlet, and remove the valve from the power unit.

Disassembling Lower Valves

1. Remove the pipe nipple and pipe coupler from the lower cap.
2. Remove the two (2) socket cap screws from the lower cap.
3. Remove the lower cap from the machined body.
4. Remove the six (6) socket cap screws from the end plate. Separate the end plate from the machined body.
5. Remove the cotter pin from the plunger. Unscrew the plunger from the air cylinder shaft.
6. Remove the four (4) socket cap screws holding the air cylinder to the end plate.

Servicing and Reassembling Lower Valves

1. Clamp the air cylinder in a vise and unscrew the end cap. Using parts from the valve service kit, replace the seals in the air cylinder. Screw the end cap back on.
2. Secure the air cylinder to the end plate using the four (4) socket cap screws.
3. Screw the two (2) plunger support disks and a new plunger on the air cylinder shaft.
4. Thread the locknut back on the air cylinder shaft.
5. Place a new gasket on the end plate; secure the end plate and valve body using six (6) socket cap screws.
6. Reconnect the lower cap to the air cylinder using two (2) socket cap screws and a new O-ring.

Reinstalling Lower Valves

1. Replace the O-ring in the valve body.
2. Position the valve back on the vacuum power unit. Tighten the set screws that secure the valve to the blower outlet.
3. Insert the silencer into the valve body, and bolt it to the base at the bracket. Screw the vertical silencer back on.
4. Reconnect the compressed air line to the valve.
5. Reconnect the valve to the T-Y tube using the radiator hose and hose clamps. Tighten the hose clamps.

Maintaining Vacuum Receivers and Filter/ Receiver Combinations

- Clean the vacuum receiver filter cartridges as needed. Blow clean with compressed air. Blow out from the inside for best results. If the screen becomes bent or warped, or the gasket becomes worn, replace it to prevent material carry-over to the SFC filter chamber.
- Clean and inspect the gasket. Replace it if it is worn.
- Invert SSR Series vacuum hoppers onto their flat covers for easier maintenance.
- If the optional SSR Series vented internal sequencing valve is installed, make sure you remove compressed air *prior* to servicing.
- If optional supplemental cloth filter bags are being used, periodically inspect for wear and fouling. Clean or replace as necessary.

5-3 Cleaning the Collection Bin (All Models Except SFC 225 and SFC 1000)

Use the following procedure to clean the collection bin:

1. Open the toggle fasteners on the bottom of the filter
2. Remove the collection bin.
3. Empty contents of the collection bin and completely clean it.
4. **SFC-A/SFC-K Only:** Adjust the counterbalance so that the dump valve remains open from 3/16" to 1/4" (4 mm to 6 mm) when not under vacuum.
5. Wipe down the gasket and collection bin mating surfaces to ensure a good seal. A good vacuum seal is important for proper operation. Replace gasket if necessary.
6. Check the filter element for excessive wear or damage. If the filter element is damaged, replace it immediately. (See Section 5-5 Cleaning/replacing the filter cartridge).
7. Return the collection bin to the bottom of the filter.
8. Close the toggle fasteners.

5-4 Cleaning the Filter Shroud (SFC 225 and SFC 1000 Only)

Use the following procedure to clean the filter shroud:

1. Remove the dust container from the filter shroud by unclamping the band clamp or loosening the drawstring. (Filters that have been trimmed for 5-gallon pails do not have a drawstring.)
2. Empty the contents of the collection bin and completely clean it.
3. Remove the worm clamp from the bottom of the filter stand mounting plate, and remove the filter shroud.
4. Clean the filter shroud by blowing compressed air through it.
5. Slip the filter shroud over the retaining ring located on the bottom side of the filter stand mounting plate. Secure it with the worm clamp provided.
6. Place the dust container below the filter chamber stand and insert the filter shroud.
7. Fasten the filter shroud to the dust container using either a band clamp or the drawstring. (Filters that have been trimmed for 5-gallon pails do not have a drawstring.)

5-5 Cleaning/Replacing the Filter Cartridge SFC-S

Use the following procedure to clean or replace the filter cartridge:

1. Unlatch the four (4) clamps that hold the collection bin to the filter assembly.
2. Discard contents of the collection bin if needed.
3. Loosen and remove the wing bolt that holds the filter cartridge in place.
4. Remove the filter cartridge from the assembly.
5. Use compressed air to clean the filter cartridge. Blow from the inside to the outside of the filter cartridge. Make sure that the compressed air pressure is less than 100 PSI (6.9 Bar) to keep from damaging the filter. Replace the filter cartridge if it shows signs of wear.
6. Wipe down the gaskets on the filter cartridge and on the filter assembly where the collection bin will meet.
7. Re-install the filter cartridge. Make sure the filter cartridge is properly seated in the housing, and bolt it into the assembly.
8. Replace the collection bin and re-latch the clamps that hold it into place.

Spare Parts

Filter Cartridge: A0571262

SFC 225 and SFC 1000

Use the following procedure to clean or replace the filter cartridge:

1. Unlatch the clamp that secures the cover assembly.
2. Lift off the cover.
3. Unscrew the retaining cover, and remove the filter cartridge.
4. Use compressed air to clean the filter cartridge. Blow from the inside to the outside of the filter cartridge. Make sure that the compressed air pressure is less than 100 PSI (6.9 Bar) to keep from damaging the filter. Replace the filter cartridge if it shows signs of wear.
5. Wipe down the gasket and filter retainer cover mating surfaces to ensure a good seal.
6. Re-install the filter cartridge. Make sure the filter cartridge is properly seated in the housing.
7. Re-install the retaining cover. A snug fit is required for a proper fit. Do not over tighten the retaining cover.
8. Place the cover on top of the filter assembly
9. Latch the clamp that secures the cover assembly.

Spare Parts

XFC 225 Filter Cartridge: A0547008
XFC 1000 Filter Cartridge: A0547007

5-6 Corrective Maintenance

Dealing with Shortened ACA Series Filter Bag Life

If ACA filter bags wear out rapidly, refer to the following list to diagnose certain difficulties:

Chemical Attack

Filter bag material may degrade from certain chemicals in the dust of the air stream.

Moisture

Filter bag material may shrink or degrade from excessive moisture in the filter chamber.

Abrasion

If filter bags are improperly installed, bags can rub together or against filter chamber walls, resulting in excessive wear. Abrasion on the filter bags near the air inlet area indicates that a dust-impingement baffle may be required.

High Temperature

If operating temperatures are above the recommended limit for filter bag material, damage may result.

Consult the Service Department for assistance if difficulties occur.

Chapter 6: Troubleshooting

6-1 Introduction

The utmost in safety precautions should be observed at all times when working on or around the machine and the electrical components. All normal trouble-shooting must be accomplished with the power off, line fuses removed, and with the machine tagged as out of service.

The use of good quality test equipment cannot be over-emphasized when troubleshooting is indicated. Use a good ammeter that can measure at least twice the AC and DC current that can be encountered for the machine. Be sure that the voltmeter has at least minimum impedance of 5,000 OHMS-per-volt on AC and 20,000 OHMS-per-volt on DC scales. Popular combination meters, VOM and VTVM can be selected to provide the necessary functions.

Before making haphazard substitutions and repairs when defective electrical components are malfunctioning, we recommend that you check the associated circuitry and assemblies for other defective devices. It is common to replace the obviously damaged component without actually locating the real cause of the trouble. Such hasty substitutions will only destroy the new component. Refer to wiring diagrams and schematics.

Locating mechanical problems, should they occur, is relatively straightforward. When necessary, refer to the parts catalog section.

Note: Refer to specific control panel operation and instruction manual for additional details and Troubleshooting information.

Problem	Possible Cause	Possible Remedy
The pump doesn't run even though it is on line. (Refer to enclosed Control Panel Manual)	The motor overload tripped.	Reset the overload and check the motor for the proper amp draw as listed on the serial tag.
	No demand signal/stations offline.	Check control panel.
	Control panel problem.	Verify wire connections. Inspect output cards.
	Main fuse in power drop or optional fused disconnect has blown.	Replace the fuse.
		Check for 3-phase voltage.
Motor contactor is faulty.	Repair or replace as required.	

Problem	Possible Cause	Possible Remedy
<p>A vacuum receiver bypasses in the Loading cycle. (Refer to enclosed Control Panel Manual)</p>	The bin below the vacuum receiver is full if the amber receiver indicator light is off.	Normal operation. When hopper level drops, material begins conveying to it.
	The receiver is off line.	Put it on line via menus.
	Static convey time was set to zero.	Put in a reasonable convey time via menus.
	Field installed station bypass switch is simulating a bin-full condition.	Normal operation. Throw field-installed switch to put hopper back in the loading sequence.
	The field-installed station bypass switch is bad or miswired.	Repair, replace, or rewire.
	Insufficient compressed air to shift valves.	Supply 80 psi (552 kPa) compressed air to all compressed air- operated valves.
	The Bin-Full switch sensor fails to close.	Standard switch is normally open, held closed by the magnet. Check for the presence of the magnet and for proper switch operation.
	The Receiver-Full proximity sensor is fouled, creating a false reading (Volume Fill systems only).	Wipe off the proximity sensor. Re-adjust if needed; see Page 76.
<p>Pressure is present at the vacuum inlet.</p>	The Receiver-Full proximity sensor has failed closed (Volume Fill systems only).	Replace.
	Improper pump rotation.	Switch any two wires at the incoming power.
<p>No-Convey alarm. (Part of vacuum control panel. Refer to enclosed Control Panel Manual)</p>	Blowback solenoid failed open.	Check filter chamber or pump.
	Material supply empty.	Refill the supply.
	Material supply bridging.	Agitate material supply.
	Pick up device not in supply.	Re-insert the probe.
	Flapper stuck in open position.	Clear flapper of obstructions.
	Power to vacuum pump off.	Inspect power.
	Bad level sensor.	Replace level sensor.
	Plugged material line.	Find and remove obstruction.
Vacuum line leak.	Find and repair leak.	
Sequence-T valve problem (where used).	Check for signal, sufficient compressed air, proper wiring and operation.	

Problem	Possible Cause	Possible Remedy
High-Vacuum alarm.	Material or vacuum line plugged.	Find and remove the obstruction, such as a coupling gasket and gaylord bags.
	Filter chamber filter dirty.	Clean filter.
	Vacuum hopper filter dirty.	Clean filter.
	Bad atmospheric/sequence-T valve.	Check for signal, sufficient compressed air, proper wiring and operation.
	Vent valve on pump package not operating correctly.	Check for signal, sufficient compressed air, proper wiring and operation.
	Improper piping.	Locate and correct.
	Convey time set too long.	Reduce convey time.
	Collapsing hoses.	Inspect hoses.
	Faulty vacuum switch.	Test – ON – replace switch.
	Take off compartment closed.	Adjust take-off box.
Vacuum receivers are being overfilled. (Refer to enclosed Control Panel Manual)	Conveying times are too long (Time Fill only).	Observe and time the hopper(s) when loading. Note the time needed to fill a hopper. Set the conveying time to a few seconds less.
	Special convey enabled.	
	Maximum conveying times are too long (Volume Fill only) and the Receiver Full proximity switch(es) are not being recognized by the PLC.	Check proximity sensors for proper operation and proper wiring to PLC. Repair. Re-set the conveying times to reasonable times. Re-adjust if needed; see Page 76.
Vacuum receivers are being under-filled.	Poor take-off adjustment.	Observe and time the hopper(s) when loading. Note the time needed to fill a hopper. Set the conveying time to a few seconds more.
	Conveying times are too short (Time Fill only). (See control panel's O & I.)	
	Vacuum line leak.	Find and repair leak.
	No material to convey.	Make sure pickup probe is buried in material source.
	Vacuum filter is plugged.	Clean and/or replace filter.

Problem	Possible Cause	Possible Remedy
Filter chamber filter cartridge is becoming obstructed too frequently by fines and dust.	Dump Delay time set to zero, or insufficient dump delay time.	Set dump delay time to the time it takes the largest vacuum hopper in the system to dump.
	Dusty material. Optional cyclone separator or low-head separator may be needed – Consult sales rep.	Consult sales representative.
	Dusty material — Optional compressed air filter cleaning may be needed on filter chamber.	Consult sales representative.
Pumps and receivers are on-line, but the pumps are not conveying material. (Refer to enclosed Control Panel Manual for specific instructions.)	No material demand at receivers if none of the amber lights on the optional light board are lit.	Normal operation. Pump packages shut off thirty (30) seconds after no demand is detected for the time programmed.
	The on-line receivers are not assigned to the pumps that are on-line.	Reconfigure the control panel, assigning the pumps to the desired hopper.
Optional audible/visual alarm continues to signal after the Press-To-Silence button is pressed. (Refer to enclosed Control Panel Manual for specific instructions.)	The alarm is triggered every time an alarm message displays.	<p>In cases where numerous alarm conditions occur, alarm messages build up in the display buffer. Each time one is released from the buffer, the alarm sounds.</p> <p>The operator may:</p> <ul style="list-style-type: none"> • Press the silence button after each message • Disable the alarm using the control panel keypad • Cancel No-Convey alarm(s) ①. <p>Correct the problem causing the alarm. Alarm will not trigger again until another high vacuum condition occurs. If multiple alarm messages are in the buffer, the button may need to be pressed a few times.</p>

① To cancel No Convey alarm(s):

- Take the problem receiver(s) off line with field-installed station bypass switches.
- Take the problem receiver(s) off line with the control panel.
- Remove the material demand by filling the bin below the vacuum receiver.

Problem	Possible Cause	Possible Remedy
Optional audible alarm is not functioning. (Refer to enclosed Control Panel Manual for specific instructions.)	The alarm package is wired incorrectly.	Correct wiring. Consult wiring diagram.
	Alarm package component failure.	Troubleshoot and repair/replace problem.
Vacuum conveying rate is declining due to a vacuum loss in the system.	Pump package blower problem. Use a cfm/cfh monitoring device to ensure that blower cfm/cfh is to the manufacturer's specifications. Consult Service Engineer if problem persists.	<ul style="list-style-type: none"> • Blower is dead-headed. Check for obstruction. • Vent valve is not operating. Check for proper signal, voltage, and 80 to 90 psi (552 to 621 kPa) compressed air. • Worn seals in blower. Rebuild/replace blower. • Worn bearings in blower. Rebuild or replace. • Loose drive belt(s). Tighten or replace if worn.
		Follow the vacuum path from the blower through the filter, piping, valves and material receivers to isolate where the loss occurs.
		Filter chamber problem. The vacuum at the filter chamber should be the same as the blower generates. If the vacuum at the filter chamber is adequate, the problem is down line.

Problem	Possible Cause	Possible Remedy
<p>Vacuum conveying rate is declining due to a vacuum loss in the system. (Cont'd.)</p>	<p>Pump package blower problem. Use a cfm/cfh monitoring device to ensure that blower cfm/cfh is to the manufacturer's specifications. (Cont'd.)</p> <p>Consult Service Engineer if problem persists.</p>	<p>Dirty filter. Clean or replace filter.</p> <ul style="list-style-type: none"> • Loose clamps, gaskets or couplers. Tighten or replace. • Filter chamber discharge flapper not sealing under vacuum. Check for proper operation; clean or repair as needed. • Check for faulty compressed air blowback solenoid. Check for voltage signal during cleaning cycle, proper solenoid operation, incorrect wiring, proper compressed air connection, and for worn plunger in valve.
	<p>Vacuum line problem. Disconnect the vacuum line at the first vacuum hopper and block it off. The vacuum here should equal the vacuum at the blower. Allow a few seconds for vacuum to build. If the vacuum here is low, disconnect the piping halfway to the first vacuum hopper and check the vacuum there. If proper vacuum exists, the problem is upstream. If not, work backward to isolate the vacuum loss.</p>	
	<ul style="list-style-type: none"> • Tighten loose pipe couplers; replace worn gaskets as needed. • Replace any damaged piping found. 	
	<p>Leaks in vacuum lines between valves.</p>	<p>Check for leaks as described in previous steps.</p>

Problem	Possible Cause	Possible Remedy
<p>Vacuum conveying rate is declining due to a vacuum loss in the system.</p> <p>(Cont'd.)</p>	<p>Vacuum leak(s) in vacuum hoppers.</p>	<ul style="list-style-type: none"> • Replace or re-install worn or misaligned gaskets. • Hopper discharge flapper not sealing under vacuum. <ol style="list-style-type: none"> 1) Replace worn or missing gasket. 2) Clean fouled flapper. 3) Check counterweight for proper operation. Repair or adjust as needed. • Internal check valves missing or damaged. On single line Y systems, internal check valves must be installed in the vacuum hoppers to seal all hoppers not being conveyed to. If the check valves are present and undamaged, they may be pushed too far onto the tube stub to permit a proper seal. Also, if the hopper is over-filled, the check valve may not seal properly.
	<p>Vacuum leaks in material lines.</p>	<p>Check for leaks as described in previous steps.</p>
	<p>Material take-offs not properly adjusted.</p>	<p>Too much air and not enough material or too much material and not enough air. Close takeoff compartment material inlet, slowly open until you hear material surging and slugging. Close material inlet until surging disappears. On most systems, a proper adjustment generates a 6" to 10" Hg (203 to 339 millibars) vacuum.</p>
	<p>The blower is dead-headed.</p>	<p>Check the blower inlet for obstruction.</p>

Problem	Possible Cause	Possible Remedy
Material is sucked from the filter chamber and through the blower.	Filters in the filter chamber are dislodged, worn, or not seated properly on the gasket.	Replace or repair immediately . If the exhaust silencer has material in it, replace it to prevent fire hazard.
	The material conveyed is not what the system was designed to convey. Very dusty materials have different conveying needs.	Consult manufacturer for advice on hardware requirements.

Other service problems or questions can be answered by contacting the Service Department.

Chapter 7: Appendix

7-1 Warranty

Unless otherwise specified, this product includes a Standard ONE YEAR PARTS AND LABOR WARRANTY.

Warranty Specifications

The manufacturer hereby expressly warrants all equipment manufactured by it to be free from defects in workmanship and material when used under recommended conditions, as set forth in the operating manuals for such equipment. THE FOREGOING EXPRESS WARRANTY IS EXCLUSIVE AND IN LIEU OF ALL OTHER WARRANTIES, GUARANTEES, AGREEMENTS, AND SIMILAR OBLIGATIONS OF THE COMPANY AND/OR MANUFACTURER (UNLESS OTHERWISE SPECIFIED IN THE SPECIFIC PRICE PAGE OR LIMITED BY THE MANUFACTURERS' WARRANTY FOR PARTS). The Company's obligation is limited to repair or replace FOB the factory any parts that are returned, prepaid, within one year of equipment shipment to the original purchaser, and which in the Company's opinion, are defective. Any replacement part assumes the unused portion of this warranty.

Warranty Restrictions

This parts warranty does not cover any labor charges for replacement of parts, adjustment repairs, or any other work. This warranty does not apply to any equipment which, in the Company's opinion, has been subjected to misuse, negligence, or operation in excess of recommended limits, including freezing or which has been repaired or altered without the Company's express authorization. If the serial number has been defaced or removed from the component, the warranty on that component is void. Defective parts become the property of the warrantor and are to be returned immediately, without any further use or handling.

Warranty Liabilities

THE COMPANY EXPRESSLY DISCLAIMS ANY AND ALL LIABILITY FOR ANY SPECIAL, CONSEQUENTIAL OR INCIDENTAL DAMAGES OR EXPENSES THAT RESULT FROM THE USE OF THIS PRODUCT. Some states do not allow the exclusion or limitation of special, consequential or incidental damages, so the above limitation may not apply to you. The Company's obligation for parts not furnished as components of its manufactured equipment is limited to the warranty of the manufacturers of said parts. The company neither assumes nor authorizes any other persons to assume for it any liability in connection with the sale of its equipment not expressed in this warranty. No person, agent, manufacturer, distributor, dealer, installer or company is authorized to change, modify or extend the terms of this warranty in any manner whatsoever.

The time within which an action must be commenced to enforce any obligation of the Company's arising under this warranty, or under any statute or law of the United States or any state thereof, is hereby limited to the duration of this warranty. Some states do not permit this limitation, so the above may not apply to you. This warranty gives you specific legal rights and you may also have other rights which vary from state to state. For transactions involving the potential applicability of international law or that of a foreign country, this warranty policy and the procedures hereunder shall be governed by applicable federal and state law, but not by the United Nations Convention on Contracts for the Sale of Goods.

Customer Responsibilities

Any sales, use, or other tax incident to the replacement of parts under this warranty is the responsibility of the purchaser.

7-2 Technical Specifications

The following design information is provided for your reference:

1. No modifications are allowed to this equipment that could alter the CE compliance
2. Ambient temperature: 40 degrees Celsius – Maximum (104 degrees Fahrenheit)
3. Humidity range: 50% relative humidity
4. Altitude: Sea level
5. Environment: Clean, dust-free and non-explosive
6. Radiation: None
7. Vibration: Minimal, i.e. machine mounting
8. Allowable voltage fluctuation: +/- 10%
9. Allowable frequency fluctuation: Continuous +/- 1%
Intermittent +/- 2%
10. Nominal supply voltage: 460/3/60 (Verify on serial number tag)
11. Earth ground type: TN (system has one point directly earthed through a protective conductor)
12. Power supply should include a ground connection.
13. Over-current protection is supplied in the conveying system, but additional protection should be supplied by the user.
14. The door-mounted disconnect serves as the electrical disconnect device.
15. Conveying system is not equipped with local lighting.
16. Functional identification
17. Conveying system is equipped with a CE mark
18. Conveying system is supplied with an operating manual in the language of the destination country.
19. Cable support may be required for power cord, depending on final installation.
20. No one is required to be in the interior of the electrical enclosure during the normal operation of the unit. Only skilled electricians should be inside the enclosure for maintenance.
21. Doors can be opened with a screwdriver, but no keys are required.
22. Two-hand control is not required or provided.
23. All components should be moved around and set in a place with a lift truck or equivalent.
24. There are no frequent repetitive cycles that require manual control—repetitive functions are automatic while the conveying system is operating.
25. An inspection report detailing the functional test is included with the conveying system.
26. The machine is not equipped with cableless controls.
27. Color-coded (harmonized) power cord is sufficient for proper installation.

7-3 Drawings and Diagrams

Figure 42: Non-Reversing Valve Cycle of Operation (SPDB Pumps)

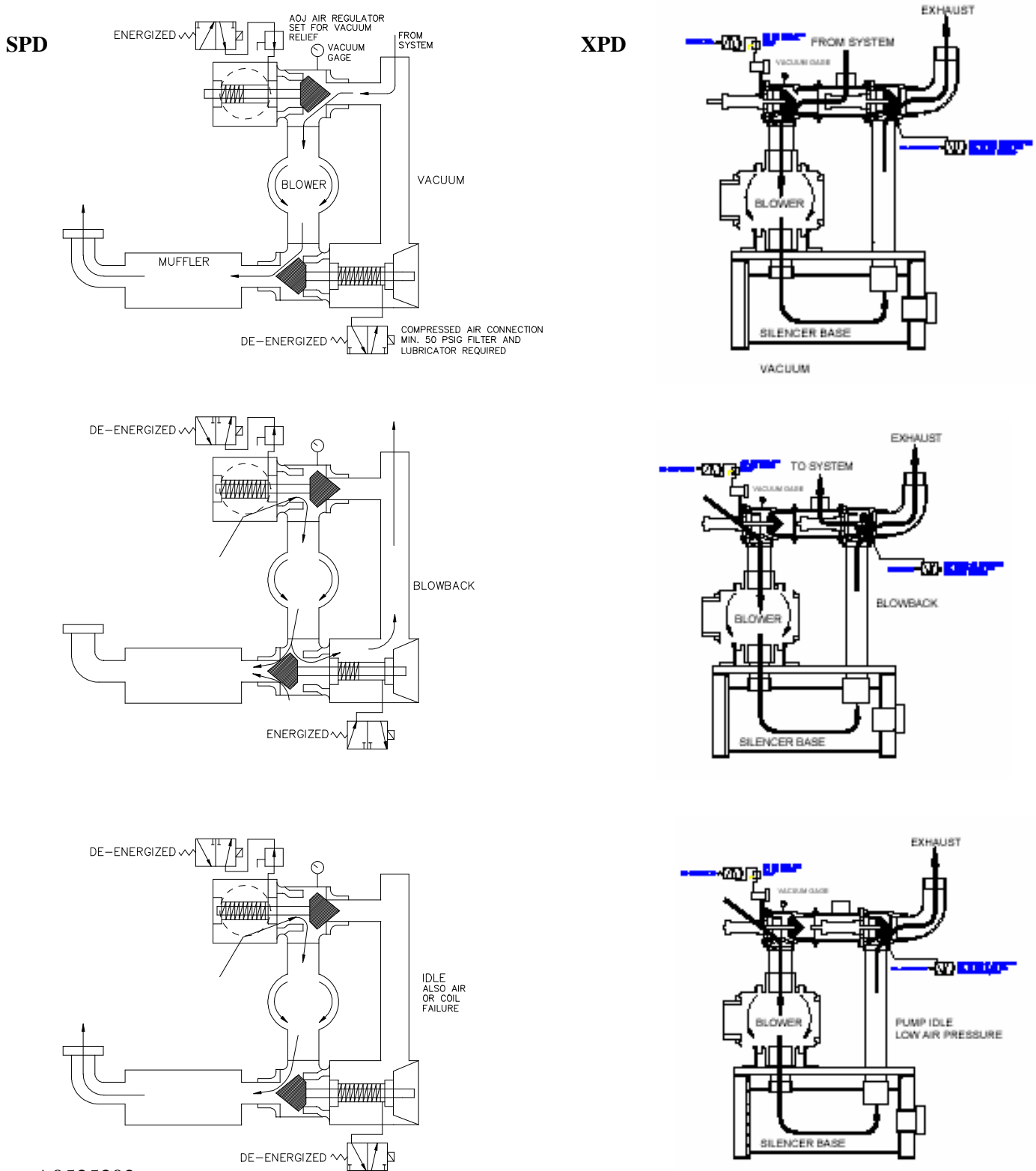

Figure 43: Equipment Cycles

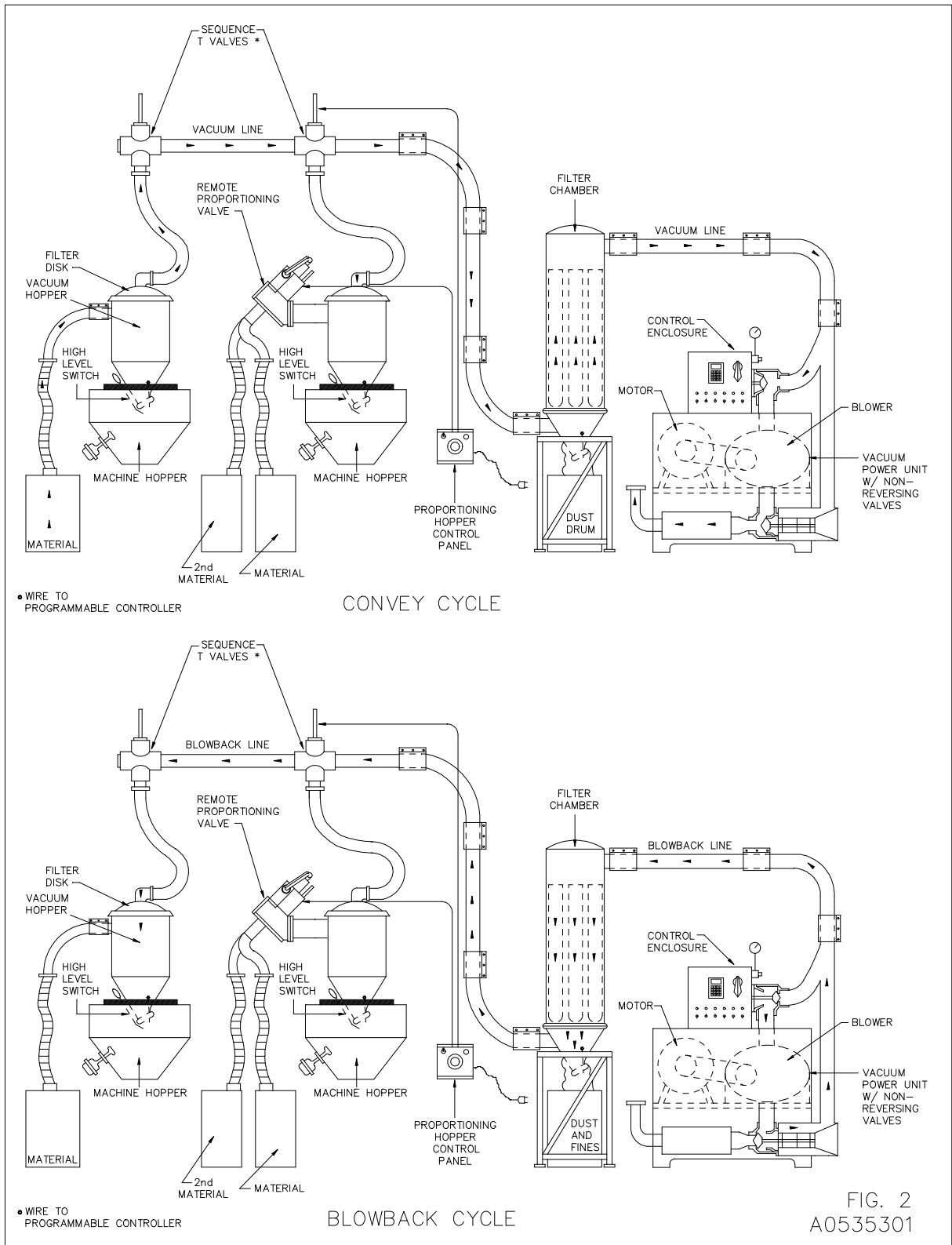

FIG. 2
A0535301

-Notes-

7-4 Spare Parts List

Figure 44: Typical SSR Series Vacuum Receiver Exploded View

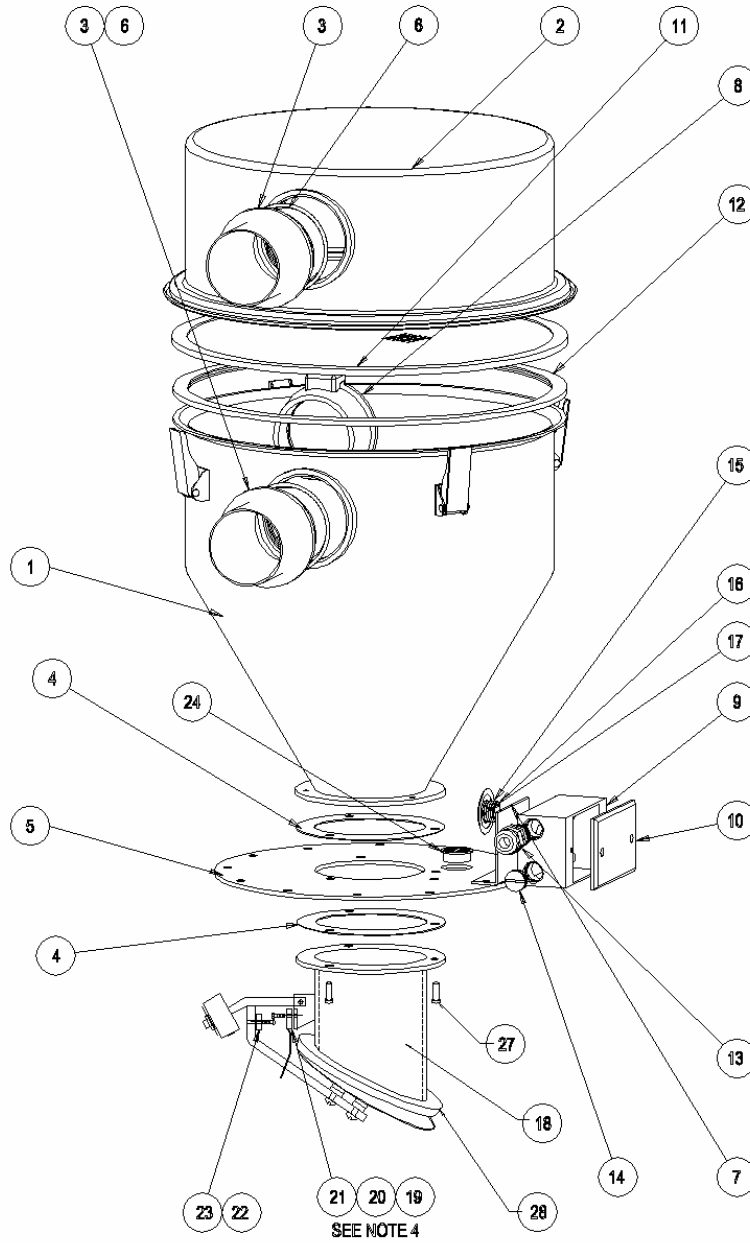

Figure 45: Series Vacuum Receiver Parts List

See Figure 44 for parts location.

Item	Model no.	Quantity	Part no.	Description
1	SSR06	1	A0563504	CONE, WELD, 9" DIA., SSR06
	SSR11	1	A0563505	CONE, WELD, 9" DIA., SSR11
	SSR23	1	A0563506	CONE, WELD, 14" DIA., SSR23
	SSR45	1	A0563507	CONE, WELD, 14" DIA., SSR45
2	SSR06-11	1	A0556507	COVER, WELD, 9" DIA., SSR06-11
	SSR23-45	1	A0556508	COVER, WELD, 14" DIA., SSR23-45
3	SSR06-11	2	A0556504	TUBE, INLET/OUTLET, 1-1/2," SSR06-11
	SSR06-11	2	A0556505	TUBE, INLET/OUTLET, 2.0," SSR06-11
	SSR23-45	2	A0556518	TUBE, INLET/OUTLET, 2.0," SSR23-45
	SSR23-45	2	A0556519	TUBE, INLET/OUTLET, 2.5," SSR23-45
	SSR23-45	2	A0556520	TUBE, INLET/OUTLET, 3.0," SSR23-45
	SSR23-45	2	A0559438	TUBE, INLET/OUTLET, 3.5," SSR23-45
4	SSR06-45	2	A0563513	GASKET, THROAT, SEAL, SSR
5	SSR06-45	1	A0567621	FLANGE, MTG., 12" DIA., SSR06-45
6	SSR06-45	2	A0556546	ORING, SILICONE, 3.234 IDx0.139 THK
7	SSR06-45	1	A0563516	BRACKET, J BOX, SSR06-45
8	SSR06-11	1	A0559419	CHECK VALVE, 1.5", URETHANE
	SSR06-45	1	A0559420	CHECK VALVE, 2.0", URETHANE
	SSR23-45	1	A0559421	CHECK VALVE, 2.5", URETHANE
	SSR23-45	1	A0559422	CHECK VALVE, 3.0", URETHANE
9	SSR06-45	1	A0559422	CHECK VALVE, 3.0", URETHANE
10	SSR06-45	1	A0541037	COVER, BOX, SINGLE GANG, 4x2
11	SSR06-11	1	A0565925	FLTR, FLAT, 10.00OD, WIRE, 10 MESH
	SSR23-45	1	A0565926	FLTR, FLAT, 15.19OD, WIRE, 10 MESH
12	SSR06-11	1	A0556821	GASKET, U CHANNEL, 10" DIA, SSR06-11
	SSR23-45	1	A0555790	GASKET, U CHANNEL, 13" DIA, SSR23-45
13	SSR06-45	1	A0541039	GASKET, U CHANNEL, 13" DIA, SSR23-45
14	SSR06-45	3	A0541038	PLUG, BOX, GANG, 1/2" NPT
15	SSR06-45	1	A0003254	WASHER, REDUCER, .75"x.5"
16	SSR06-45	1	A0003217	NIPPLE, CONDUIT, 1/2" NPT
17	SSR06-45	1	A0548359	PLUG, NYLON, 5/8"
18	SSR06-45	1	A0567620	ASSEMBLY, 4" ANGLED THROAT S.S, SSR06-45
19	SSR06-45	1	A0533925	SWITCH, PROX
20	SSR06-45	2	A0567628	SCREW, BTNHD PHILLIPS, #6-32 x 1/2 LG. S.S.
21	SSR06-45	2 FT	W00000890	HOSE, RUBBER, BLK, 1/4" x 1/16"
22	SSR06-45	1	A0533924	MAGNET CERAMIC
23	SSR06-45	1	A0567627	SCREW, FLTHD, PHILLIPS, #6-32 x 1/2" LG. S.S.
24	SSR06-45	1	A0563533	VENT, LOUVER, 1" DIA, SSR
25	SSR06-45	OPT	A0548190	SWITCH, PROX, DC, NC, NPN
26	SSR06-45	OPT	A0548191	SWITCH, PROX, AC, NC
27	SSR06-45	3	W00017692	SCR, SCH, 1/4-20 x 5/8, W/PATCH
28	SSR06-45	3	W00012559	GSKT, THRT, EPT, BLACK, 4", STD TEMP
	SSR06-45	3	W00018021	GSKT, THRT, SILICONE, ORANGE, 4", HI-TEMP
	SSR06-45	3	W00016136	GSKT, THRT, NEOPRENE, WHITE, 4", STD TEMP, (FDA)

**Figure 46: Typical SSR Series Vacuum Receiver Exploded View
(SSR06-45 shown, Pre-May 2003)**

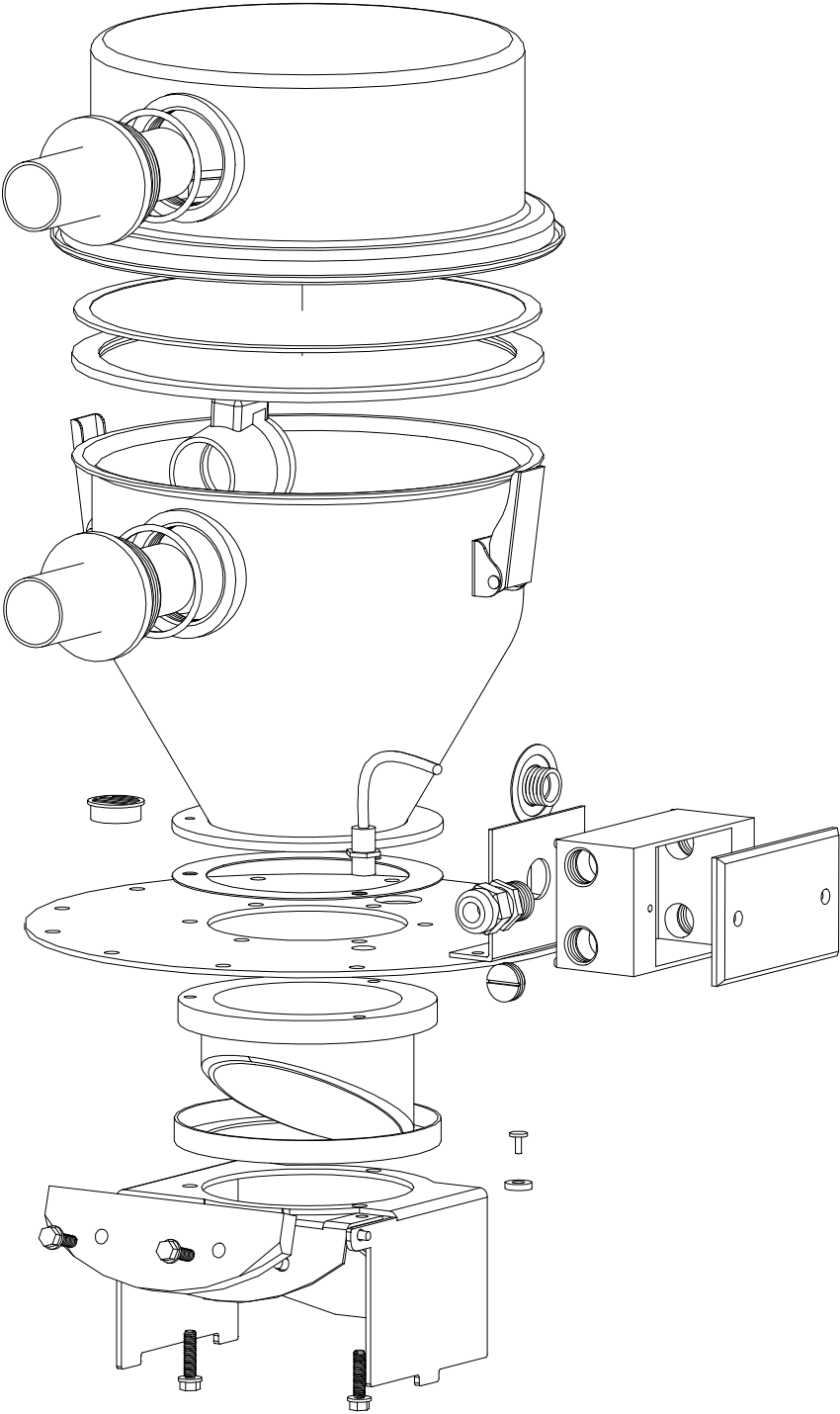

Figure 47: SSR Series Vacuum Receiver Parts List (Pre-May 2003)

Model no.	Quantity	Part no.	Description
SSR06	1	A0563504	CONE, WELD, 9" DIA.
SSR06	1	A0563505	CONE, WELD, 9" DIA.
SSR23	1	A0563507	CONE, WELD, 14" DIA.
SSR23	1	A0563508	CONE, WELD, 14" DIA.
SSR06-11	1	A0556507	COVER, WELD, 9" DIA.
SSR23	1	A0556508	COVER, WELD, 14" DIA.
SSR06-11	2	A0556504	TUBE, INLET/OUTLET, 1-1/2"
SSR23-45	2	A0556520	TUBE, INLET/OUTLET, 3"
SSR06-45	1	A0563510	FLANGE, MTG., MLD THRT, 12" DIA.
SSR06-11	2	A0553728	ORING, SILICONE, AS568-228
SSR23	2	A0556546	ORING, SILICONE, 3.234 ID X 0.139 THK
SSR06-45	1	A0563516	BRACKET, J BOX
SSR06-11	1	A0559419	CHECK VALVE, 1.5" URETHANE
SSR23	1	A0559422	CHECK VALVE, 3.0" URETHANE
ALL	1	A0541036	BOX, SINGLE GANG, 4 X 2 X 2
ALL	1	A0541037	COVER, BOX, SINGLE GANG, 4 X2
SSR06-11	1	A0556532	SCREEN, SSTL, 10 MESH
SSR23	1	A0556533	SCREEN, SSTL, 10 MESH
SSR06-45	1	A0541039	CORD GRIP, 1/2", 0.270 - 0.480
ALL	3	A0541038	PLUG, BOX, GANG, 1/2" NPT
SSR06-45	1	A0003254	WASHER, REDUCER, 0.75" X 0.5"
ALL	1	W00002373	WSHR, FLAT, PS, #10
ALL	1	W00016426	NUT, STOP, PS, 1/4-20
SSR06-45	1	A0003217	NIPPLE, CONDUIT, 1/2" NPT
SSR06-45	1	A0548359	PLUG, NYLON, 5/8"
SSR06-45	1	A0567620	ASSEMBLY, 4" ANGLED THROAT S.S
SSR/SSL06-45	1	A0563543	INSR, THRT, 4" SS
SSR/SSL06-45	1	A0563536	ASSY, FLAP/SPRT
SSR06-45	1	A0563517	THRT, SILC, 4.0 DIA***
SSR/SLC02-16	1	A0563512	CTWT, FLAP
ALL	2	A0567628	SCREW, BTNHD PHILLIPS, #6-32 X 1/2 LG. SS
ALL	1	A0567627	SCREW, FLTHD, PHILLIPS, #6-32 X 1/2" LG. SS
ALL	2 FT.	W00000890	HOSE, RUBBER, BLK, 1/4" X 1/16"
ALL	1	A0533924	MAGNET CERAMIC
ALL	1	A0563514	SW, REED, MAG, SPDT
SSR/SSL	1	A0563515	MAG, ACTUATOR, REED SW
SSR	1	A0563533	VENT, LOUVER, 1" DIA. ALUM. NATURAL
OPT.	1	A0559420	CHECK VALVE, 2.0", URETHANE
OPT.	2	A0559421	CHECK VALVE, 2.5", URETHANE
OPT.	OPT.	A0548190	SWITCH, PROX, DC, NC, NPN
OPT.	OPT.	A0548191	SWITCH, PROX, AC, NC
ALL	1	A0533925	SWITCH, PROX
SSR	3	W00017692	SSR, SHC, 1/4 - 20 X 5/8, W/PATCH
SSR06-11	2	A0556505	TUBE, INLET/OUTLET, 2" OPT.
SSR23-45	2	A0556518	TUBE, INLET/OUTLET, 2" OPT.
SSR23-45	2	A0556519	TUBE, INLET/OUTLET, 2.5" OPT.
SSR23-45	2	A0559438	TUBE, INLET/OUTLET, 3.5" OPT.
SSR06-45	1	W00012559	GSKT, THRT, EPT, BLACK, 4" STD TEMP
SSR06-45	1	W00018024	GSKT, THRT, SILICONE, ORANGE, 4" HI-TEMP
SSR06-45	1	W00016136	GSKT, THRT, NEOPRENE, WHITE, 4", STD TEMP. (FDA)
SSR06-11	1	A0556821	GASKET, U CHANNEL, 10" DIA.
SSR23-45	1	A0555790	GASKET, U CHANNEL, 13" DIA.
ALL	2	A0563513	GASKET, THROAT, SEAL
SSR06-11	1	A0563520	RING, THROAT, 4" SS

Figure 48: Typical SSR06-45 Series Vacuum Receiver Exploded View (Post May 2003)

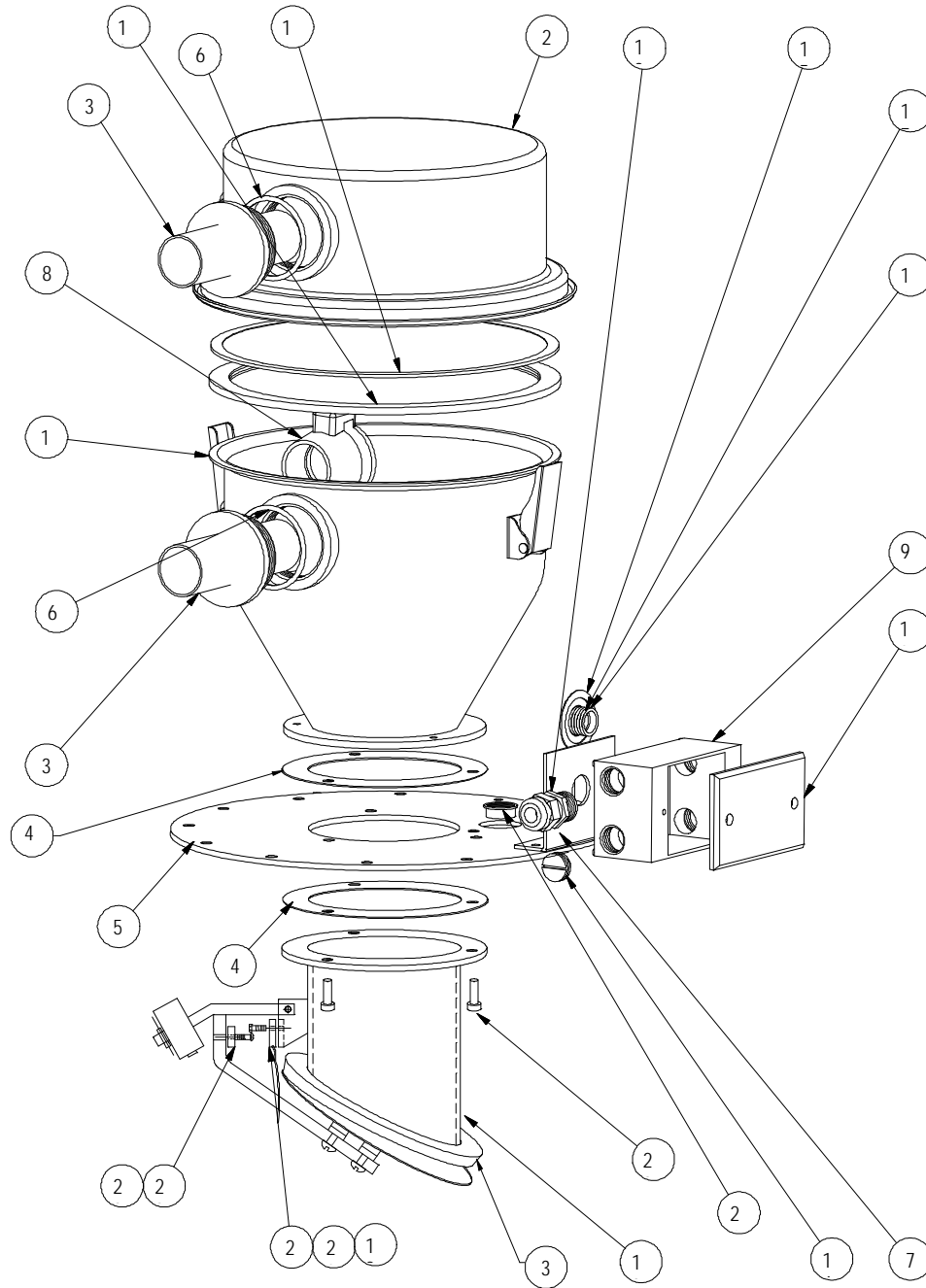

Figure 49: SSR06-16 Series Vacuum Receiver Parts List (Post-May 2003)

See Figure 48 on the previous page for parts location.

Item	Model no.	Quantity	Part no.	Description
1.	SSR06	1	A0563504	CONE, WELD, 9" DIA.
2.	SSR06-11	1	A0556507	COVER, WELD, 9" DIA.
3.	SSR06-11	2	A0556504	TUBE, INLET/OUTLET, 1-1/2"
4.	ALL	2	A0563513	GASKET, THROAT, SEAL
5.	SSR06-45	1	A0567621	FLANGE, MTG., 12" DIA.
6.	SSR06-11	2	A0553728	ORING, SILICONE, AS568-228
7.	SSR06-45	1	A0563516	BRACKET, J BOX
8.	SSR06-11	1	A0559419	CHECK VALVE, 1.5" URETHANE
9.	ALL	1	A0541036	BOX, SINGLE GANG, 4 X 2 X 2
10.	ALL	1	A0541037	COVER, BOX, SINGLE GANG, 4 X 2
11.	SSR06-11	1	A0556532	SCREEN, SSTL, 10 MESH
12.	SSR06-11	1	A0556821	GASKET, U CHANNEL, 10" DIA.
13.	SSR06-45	1	A0541039	CORD GRIP, 1/2", 0.270 - 0.480
14.	ALL	3	A0541038	PLUG, BOX, GANG, 1/2" NPT
15.	SSR06-45	1	A0003254	WASHER, REDUCER, 0.75" X 0.5"
16.	SSR06-45	1	A0003217	NIPPLE, CONDUIT, 1/2" NPT
17.	SSR06-45	1	A0548359	PLUG, NYLON, 5/8"
18.	SSR06-45	1	A0567620	ASSEMBLY, 4" ANGLED THROAT S.S
19.	SSR85	1	A0533925	SWITCH, REED, SPST, NO
20.	ALL	2	A0567628	SCREW, BTNHD PHILLIPS, #6-32 X 1/2 LG. SS
21.	ALL	2 FT.	W00000890	HOSE, RUBBER, BLK, 1/4" X 1/16"
22.	ALL	1	A0533924	MAGNET CERAMIC
23.	ALL	1	A0567627	SCREW, FLTHD, PHILLIPS, #6-32 X 1/2" LG. SS
24.	SSR	1	A0563533	VENT, LOUVER, 1" DIA.
25.	OPT.	1	A0559420	CHECK VALVE, 2.0", URETHANE
26.	SSR06-04	2	A0556505	TUBE, INLET/OUTLET, 2" OPT.
27.	OPT.	OPT.	A0548190	SWITCH, PROX, DC, NC, NPN
28.	OPT.	OPT.	A0548191	SWITCH, PROX, AC, NC
29.	SSR	3	W00017692	SSR, SHC, 1/4 - 20 X 5/8, W/PATCH
30A.	SSR06-45	1	W00012559	GSKT, THRT, EPT, BLACK, 4" STD TEMP
30B.	SSR06-45	1	W00018024	GSKT, THRT, SILICONE, ORANGE, 4" HI-TEMP
30C.	SSR06-45	1	W00016136	GSKT, THRT, NEOPRENE, WHITE, 4", STD TEMP. (FDA)

**Figure 50: Typical SSR Series Vacuum Receiver Exploded View
SSR85 (Left) & SSR170 (Right) shown, Post-May 2003)**

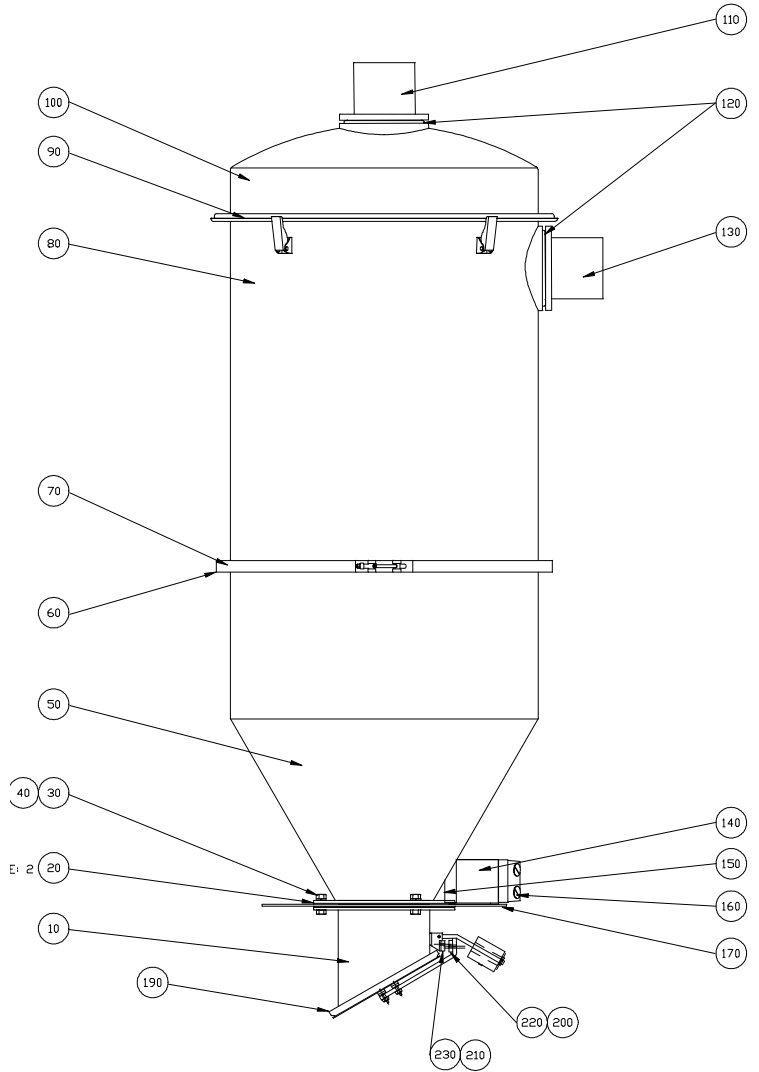
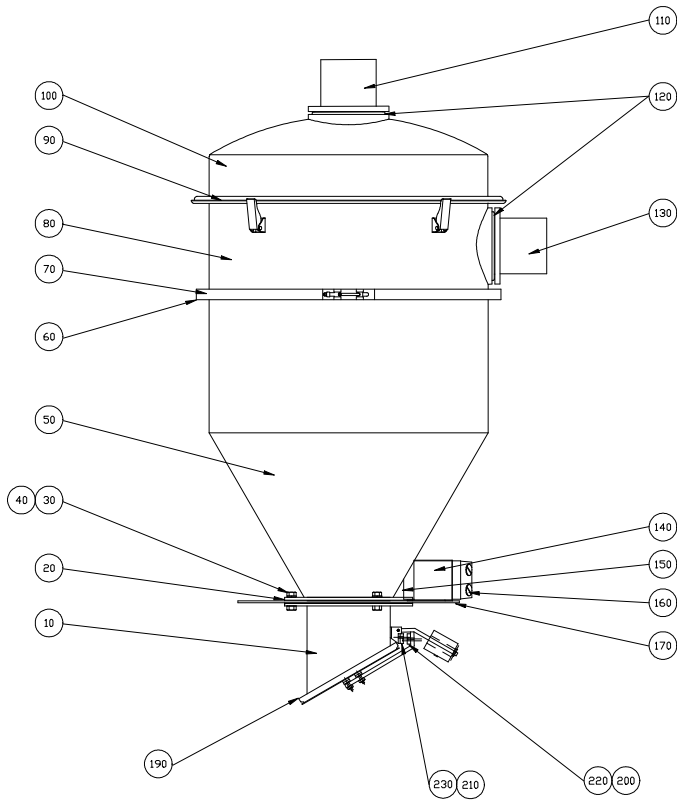

Figure 51: SSR85/170 Series Vacuum Receiver Parts List

See Figure 50 on the previous page for parts location.

Item	Model no.	Quantity	Part no.	Description
10.	SSR85/170	1	A0567619	ASSEMBLY, 6" SLANTED THROAT, SS
20.	SSR85/170	2	A0566923	GASKET, SEAL, 6" THROAT
30.	SSR85	3	A0069227	BOLT, HEX, 3/8 – 16, SS, W/PATCH
40.	SSR85	3	A00069203	WASHER, 3/8" LOCK, SS
50.	SSR85/170	1	A0566910	WELDMENT, CONE, 20" DIAMETER, SS
60.	SSR85/170	1	A0566925	CLAMP, BAND, T-BOLT, 20" SS
70.	SSR85	6 FT.	A0540240	GASKET, U-CHANNEL, NPRN, 0.56 X 0.19 X 0.6 W
80.	SSR85	1	A0566912	WELDMENT, CYLINDER, 20" DIAMETER, SS
90.	SSR85/170	1	A0566971	FILTER, DISC, 20" POLYGLAZED
100.	SSR85/170	1	A0566906	COVER, 20" DIAMETER, SS
110.	SSR85/170		A0566927	TUBE, STRAIGHT OUTLET 2" OD
	SSR85/170		A0566928	TUBE, STRAIGHT OUTLET 2.50" OD
	SSR85/170		A0566929	TUBE, STRAIGHT OUTLET 3" OD
	SSR85/170		A0566930	TUBE, STRAIGHT OUTLET 3.50" OD
	SSR85/170		A0566931	TUBE, STRAIGHT OUTLET 4" OD
	SSR85/170		A0566932	TUBE, ELBOW OUTLET 2" OD
	SSR85/170		A0566933	TUBE, ELBOW OUTLET 2.50" OD
	SSR85/170		A0566934	TUBE, ELBOW OUTLET 3" OD
	SSR85/170		A0566935	TUBE, ELBOW OUTLET 3.50" OD
120.	SSR85	2	A0566926	ORING, INLET / OUTLET SEAL
130.	SSR85/170		A0566927	TUBE, STRAIGHT INLET 2" OD
	SSR85/170		A0566928	TUBE, STRAIGHT INLET 2.50" OD
	SSR85/170		A0566929	TUBE, STRAIGHT INLET 3" OD
	SSR85/170		A0566930	TUBE, STRAIGHT INLET 3.50" OD
	SSR85/170		A0566931	TUBE, STRAIGHT INLET 4" OD
	SSR85/170		A0566932	TUBE, ELBOW INLET 2" OD
	SSR85/170		A0566933	TUBE, ELBOW INLET 2.50" OD
	SSR85/170		A0566934	TUBE, ELBOW INLET 3" OD
	SSR85/170		A0566935	TUBE, ELBOW INLET 3.50" OD
140.	SSR85/170	1	A0541036	BOX, SINGLE GANG, 4 X 2 X 2
150.	SSR85/170	1	A0563516	BRACKET, J BOX
160.	SSR85/170	3	A0541038	PLUG, BOX, GANG, 1/2" NPT
170.	SSR85/170	1	A0566915	FLANGE, MOUNTING, 16" SS
180.	SSR85/170	1	A0541037	COVER, BOX, SINGLE GANG, 4 X2
190.	SSR85/170	1	W00016928	GSKT, THRT, EPT, BLACK, 6" STD TEMP
	SSR85/170	1	A0540363	GSKT, THRT, SILICONE, ORANGE 6" HI-TEMP
	SSR85/170	1	W00018281	GSKT, THRT, NEOPRENE, WHITE, 6" STD TEMP (FDA)
200.	SSR85/170	1	A0567627	SCREW, FLTHD, PHILLIPS, #6-32 X 1/2" LG. SS
210.	SSR85/170	2	A0567628	SCREW, BTNHD PHILLIPS, #6-32 X 1/2 LG. SS
220.	SSR85/170	1	A0533924	MAGNET CERAMIC
230.	SSR85	1	A0533925	SWITCH, REED, SPST, NO
240.	SSR85/170	2 FT.	W00000890	HOSE, RUBBER, BLK, 1/4" X 1/16"
250.	OPT.	OPT.	A0548190	SWITCH, PROX, DC, NC, NPN
260.	OPT.	OPT.	A0548191	SWITCH, PROX, AC, NC

Figure 52: Typical SSI Series Inventory Vacuum Receiver Exploded View

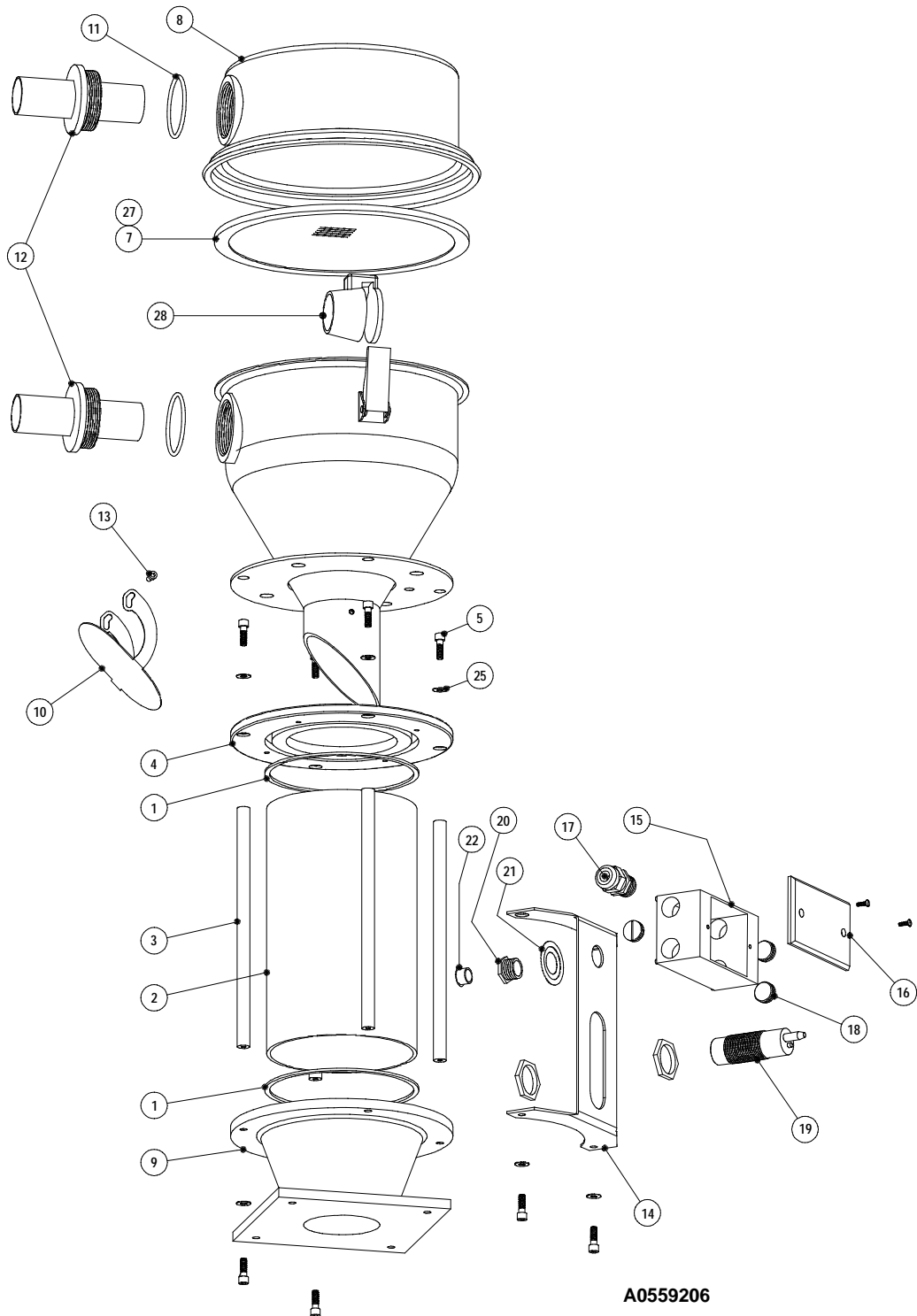

Figure 53: SSI Series Inventory Vacuum Receiver Parts List

See Figure 52 on the previous page for parts location.

Item	Model no.	Quantity	Part no.	Description
1.	SSI03	2	A0553714	GSKT, BODY, SIL, SSI/IL-01
	SSI06, 11	2	A0553722	GSKT, BODY, SIL, SSI/IL02-04
2.	SSI03	1	A0553727	GLASS, SIGHT, PYREX, SSI/IL01
	SSI06, 11	1	A0553726	GLASS, SIGHT, PYREX, SSI/IL02-04
3.	SSI03	4	A0553715	ROD, SUPT, BODY, ALU, SSI/IL01
	SSI06, 11	4	A0553723	ROD, SUPT, BODY, ALU, SSI/IL02-04
4.	SSI03	1	A0553717	PL, MACH, TOP, ALU, SSI/IL01
	SSI06, 11	1	A0553725	PL, MACH, TOP, ALU, SSI/IL02-04
5.	All	8	A0553718	SCR, SHC, SS, 1/4-20 X 3/4
	SSI03	2	A0556529	SCR, RTRCT, 1/4-20, SCO #471162210
6.	SSI03	1	A0553741	CONE, WELD, 6" ID, SSSL, SRX01
	SSI06	1	A0553742	CONE, WELD, 9" ID, SSSL, SRX02
	SSI11	1	A0553743	CONE, WELD, 9" ID, SSSL, SRX04
7.	SSI03	1	A0556531	FLTR, FLAT, WIRE, 6" OD, SSR/I01
	SSI06, 11	1	A0556532	FLTR, FLAT, WIRE, 9" OD, SSR/I02-04
8.	SSI03	1	A0556506	CVR, WELD, 6" ID, SSSL, SSI/H01
	SSI06, 11	1	A0556507	CVR, WELD, 9" ID, SSSL, SSI/H02-04
9.	SSI03	1	A0553712	BASE, MACH, BODY, ALU, SSI/IL01
	SSI03	2	A0553728	ORNG, SIL, 2.234 ID X 0.139 THK
	SSI03	1	A0553710	BASE, MACH MOUNT, THRT, SSI/IL01
	SSI06, 11	1	A0553720	BASE, MACH, BODY, ALU, SSI/IL02-04
10.	SSI03	1	A0556503	FLAP, DISCHARGE, SS, SRX01
	SSI06, 11	1	A0553731	FLAP, DISCHARGE, SS, SRXX02-04
11.	SSI06, 11	2	A0553728	ORNG, SIL, 2.234 ID X 0.139 THK
12.	SSI06, 11	2	A0556504	TUBE, IN/OUT, 1.5", SRX02-04
	SSI06, 11	2	A0556505	TUBE, IN/OUT, 2.0", SRX02-04
	SSI06, 11	2	A0555796	TUBE, IN/OUT, 2.5", SRX02-04
13.	All	2	A0556822	SCR, CAP, HEX, SOC, HD, 10-32X 1/2
14.	SSI03	1	A0553713	BRKT, JBOX/PROX, ALU, SSI/IL01
	SSI06, 11	1	A0553721	BRKT, JBOX/PROX, ALU, SSI/IL02-04
15.	All	1	A0541036	BOX, GANG, SNGLE, 4X2X2, UL WETLOC
16.	All	1	A0541037	BOX, GANG, SNGLE, COVER, BLNK, GSKT
17.	All	1	A0541039	CORD, GRIP, 1/2", .270-.480 #3231
18.	All	3	A0541038	BOX, GANG, PLUG, 1/2" NPT, UL
19.	SSI03	1	A0542138	SW, PROX, CAP, 110 VAC, 30 MM, N. C.
	SSI03	1	A0556548	SW, PROX, 30 MM, 24 V, NO/NC, #KI5208
	SSI06	1	A0548191	SW, PROX, AC/DC, 18 MM, NC, 2 WIRE
	SSI06	1	A0548190	SW, PROX, DC, 18 MM, NC, NPN, 3 WIRE
	SSI11	1	A0556537	SW, PROX, E0 MM, DC, #EC3025NPAPL
20.	All	1	A0003217	CDUT, NIPPLE, 1/2", #CN 50
21.	All	1	A0003254	RDUC, WSHR, .75"X.50" STEEL
22.	All	1	A0548359	PLUG, HEYCO, BLK, 5/8", #2663
25.	SSI06, 11	8	W00002373	WASH, FLAT, WI, 3/16", 100 PCS/#
26.	SSI06, 11	1	A0556529	SCR, RTRCT, 1/4-20, SCO #471162210
27.	SSI03	1	A0556820	GSKT, U-CHNL, NPRN, .38X.20X.06W
	SSI06, 11	1	A0556821	GSKT, U-CHNL, NPRN, .50X.20X.06W
28.	SSI06, 11	1	W00000990	VLV, CHECK, INT, 1.5" TUBE, POLY
	SSI06, 11	1	A0559420	VLV, CHECK, URETHANE, 2.0"
29.	All	2	A0536966	CONN, WIRE NUT, IDEAL #A0/A1
30.	SSI06, 11	2	W00532685	GSKT, O-RING, PARKER #2-017

Figure 54: SFC Filter Chamber Spare Parts List, Models SFC225, SFC1000

Model no.	Quantity	Part no.	Part description
SFC-225	1	A0547008	Filter, cart, wire mesh, polyester media
SFC-1000	1	A0547007	Filter, cart, wire mesh, polyester media
SFC-225	1	A0539933	Gasket, fltr, element, MVH/SFC
SFC-1000	1	A0561801	Gasket, fltr, element, MVH/SFC
All	2 ea.	A0555790	Gasket, U-channel, neoprene
SFC-225	8 ft.	A0540241	Gasket, U-channel, FDA
SFC-225	8 ft.	A0540242	Gasket, U-channel, high-temperature
SFC-1000	8 ft.	A0540240	Gasket, U-channel, neoprene
SFC-225	1	W00012559	Gasket, throat, neoprene, 4"
SFC-225	1	W00016136	Gasket, throat, FDA, 4"
SFC-225	1	W00018024	Gasket, throat, high-temperature, 4"
SFC-1000	1	W00016928	Gasket, throat, neoprene, 6"
All	1	W00001868	Shroud, filter, 50#, hopper
All	1	W00533542	Shroud, drawstring, 16" ID x 13" long

Figure 55: FC Filter Chamber Spare Parts List, Models FC15, FC30, FC35

Part number	Part description
W00012878	Gasket, channel, rubber; FC15/30
W00533541	Clamp, Vee, 17"; FC15/30
W00015675	Filter sock, poly, 25"; FC15
W00015140	Filter sock, poly, 48"; FC30/55
W00053602	Gasket, channel, neoprene; FC55
A0534113	Clamp, Vee; FC55

Note: Refer to the Bill of Materials report included in the Customer Information Packet for a complete listing of parts.

Figure 56: Vacuum Power Units; 5 to 15 hp (3.73-11.19 kW) Models Exploded View

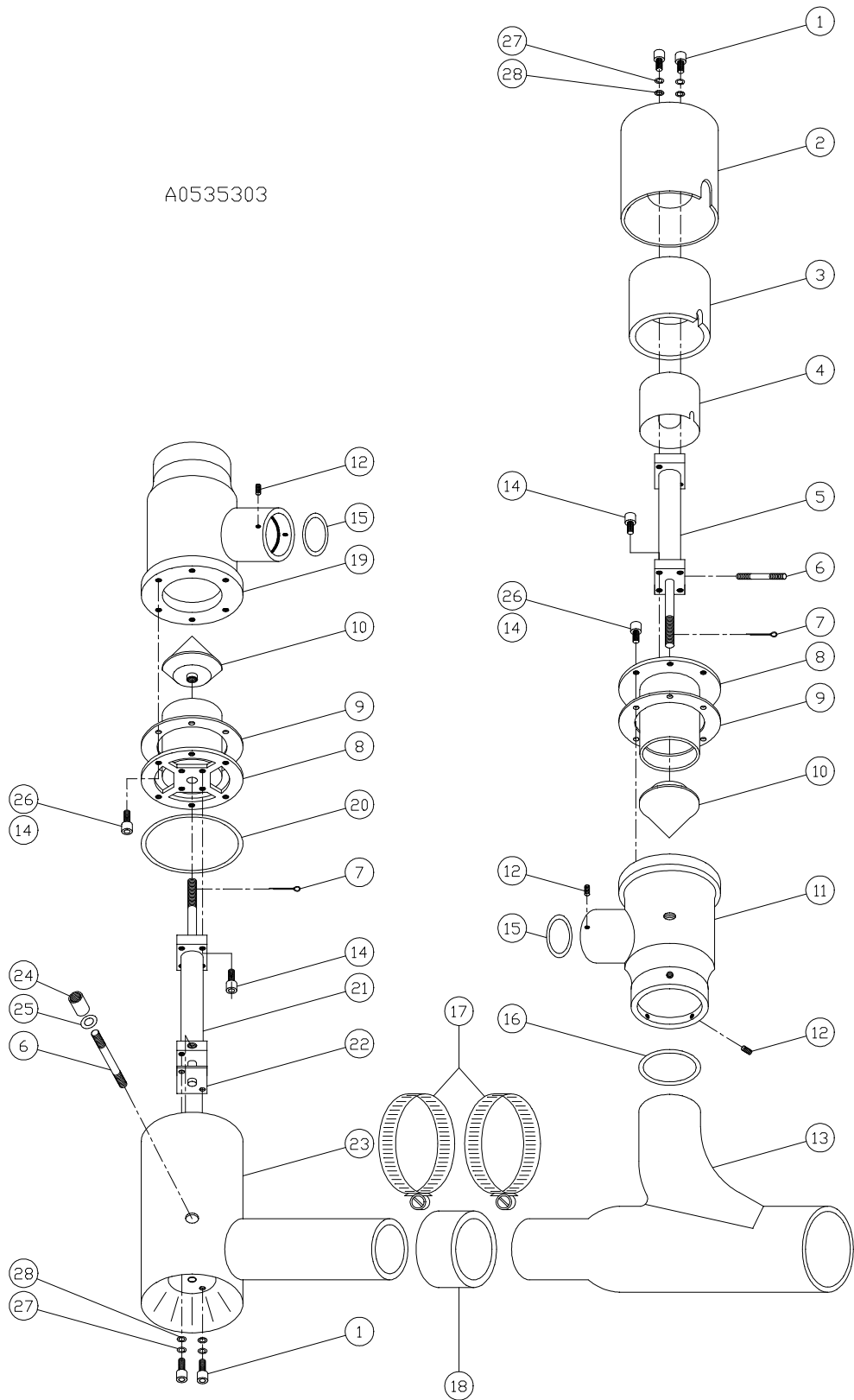

Figure 57: Vacuum Power Units; 5 to 15 hp (3.73-11.19 kW) Models Spare Parts List

Part number	Part description
W00018087	Air cylinder assembly, upper valve, includes: (1) #17688 air cylinder, (1) #1958 plunger, (1) #17812 gasket, (1) #3237 cotter pin, (1) #17957 end plate with seat, (4) #2337 socket head screws, (1) #13749 pipe nipple
W00018088	Air cylinder assembly, lower valve, includes: (1) #17529 air cylinder, (1) #1958 plunger, (1) #17812 gasket, (1) #3237 cotter pin, (1) #17639 end plate with seat, (4) #2337 socket head screws, (1) #13749 pipe nipple, and (1) 17650 O-ring
W00017529	Air cylinder, lower valve
W00017688	Air cylinder, upper valve
W00017552	Air cylinder seal replacement kit
W00052175	Belt, drive, 3VX400, 5 hp unit
W00011770	Belt, drive, 3VX475, 7½ hp unit
W00052546	Belt, drive, BX42, 10 hp unit
W00052181	Belt, drive, BX44, 15 hp unit
W00052178	Bushing, blower sheave, 7½ hp and 10 hp units
W00011490	Bushing, blower sheave, 15 hp unit
W00011494	Bushing, motor sheave, 5 hp unit
W00011491	Bushing, motor sheave, 7½ hp and 10 hp units
W00011495	Bushing, motor sheave, 15 hp unit
W00001596	Cap, end, for non-sound enclosure units
W00000334	Clamp, hose, for P/N 3816, 2½" (approx. 63.5 mm) ID hose
W00001142	Connector, 90 deg., for ¼" OD poly tube
W00013971	Connector, 90 deg., for ¼" OD copper tube
W00001135	Connector, straight, for ¼" OD poly tube
W00001781	Gasket, 1/32"
W00001043	Gauge, vacuum
W00003816	Hose, rubber, 2½" ID x 3½" long
W00052089	Silencer, discharge, horizontal
W00052014	Silencer, discharge, vertical
W00017733	Silencer, discharge, used with W00052089 on S/E units

Part number	Part description	Part number	Part description
W00011484	Sheave, blower, less bushing, 7½ hp unit	W00011483	Sheave, motor, less bushing, 7½ hp unit
W00052545	Sheave, blower, less bushing, 10 hp unit	W00052544	Sheave, motor, less bushing, 7½ hp unit
W00052183	Sheave, blower, less bushing, 15 hp unit	W00052184	Sheave, motor, less bushing, 15 hp unit

Part number	Part description	Part number	Part description
W00001045	O-ring, 2½" ID	W00014659	Solenoid valve, 115 VAC, kay valve
W00001738	O-ring, 3" ID	W00014658	Solenoid valve, 24 VDC, kay valve
W00017650	O-ring, 4¾" ID	W00018089	Spring, air cylinder
W00003237	Pin, cotter, 1/16"	W00001174	Tubing, polyethylene, ¼" OD
W00001958	Plunger, 3"	W00005592	Tubing, copper, ¼" OD
W00013961	Regulator, air pressure	A0547953	Vacuum switch, 14" Hg
W00016288	Seal, air entrance fitting	W00052055	Valve assembly, lower
W00014988	Solenoid valve, 115 VAC, vacuum-vent	W00017802	Valve assembly, upper
W00014987	Solenoid valve, 24 VDC, vacuum-vent		

Note: Refer to the Bill of Materials report included in the Customer Information Packet for a complete listing of parts.

Figure 58: Vacuum Power Units; 25 to 30 hp (18.65-22.38 kW) Models Exploded View

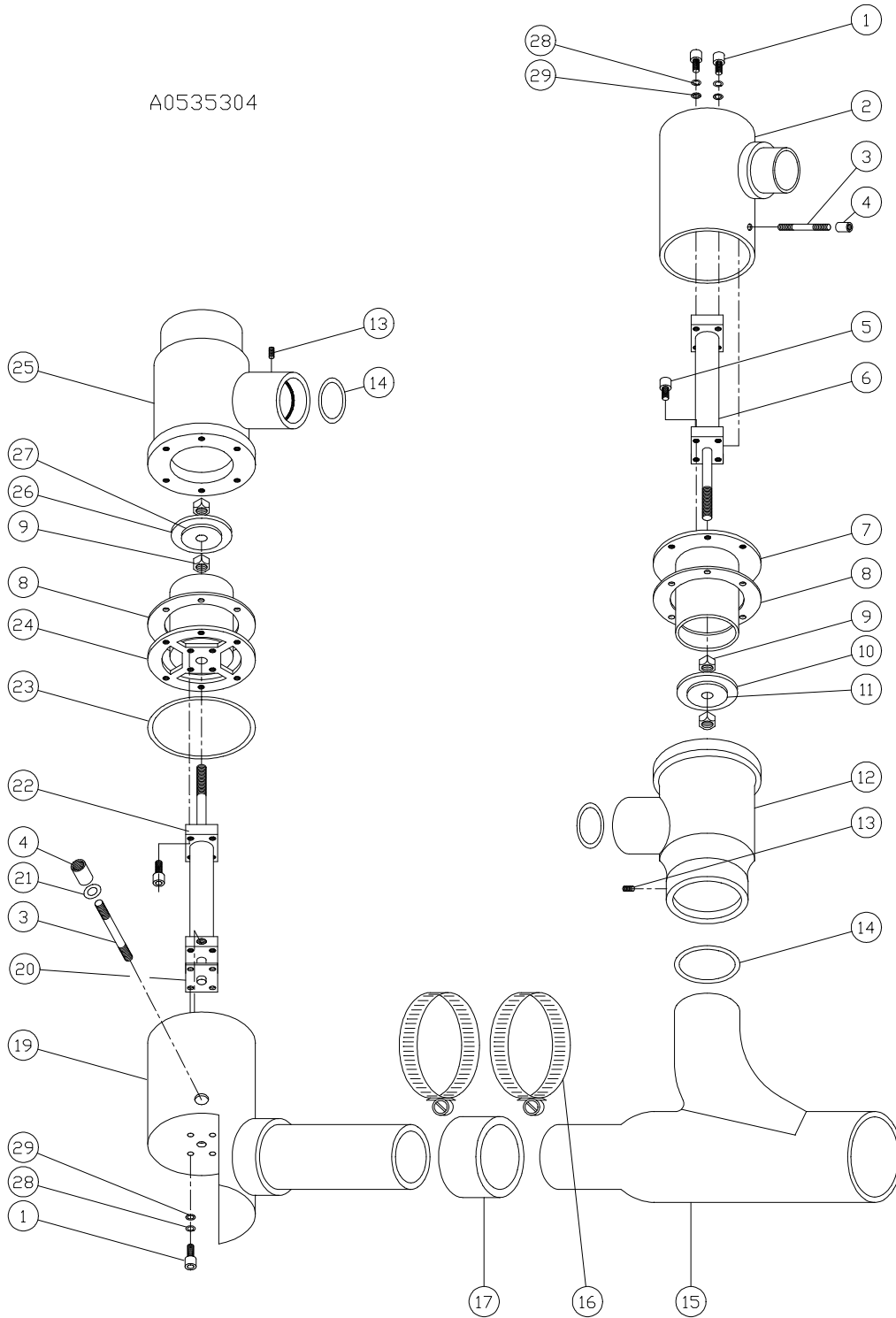
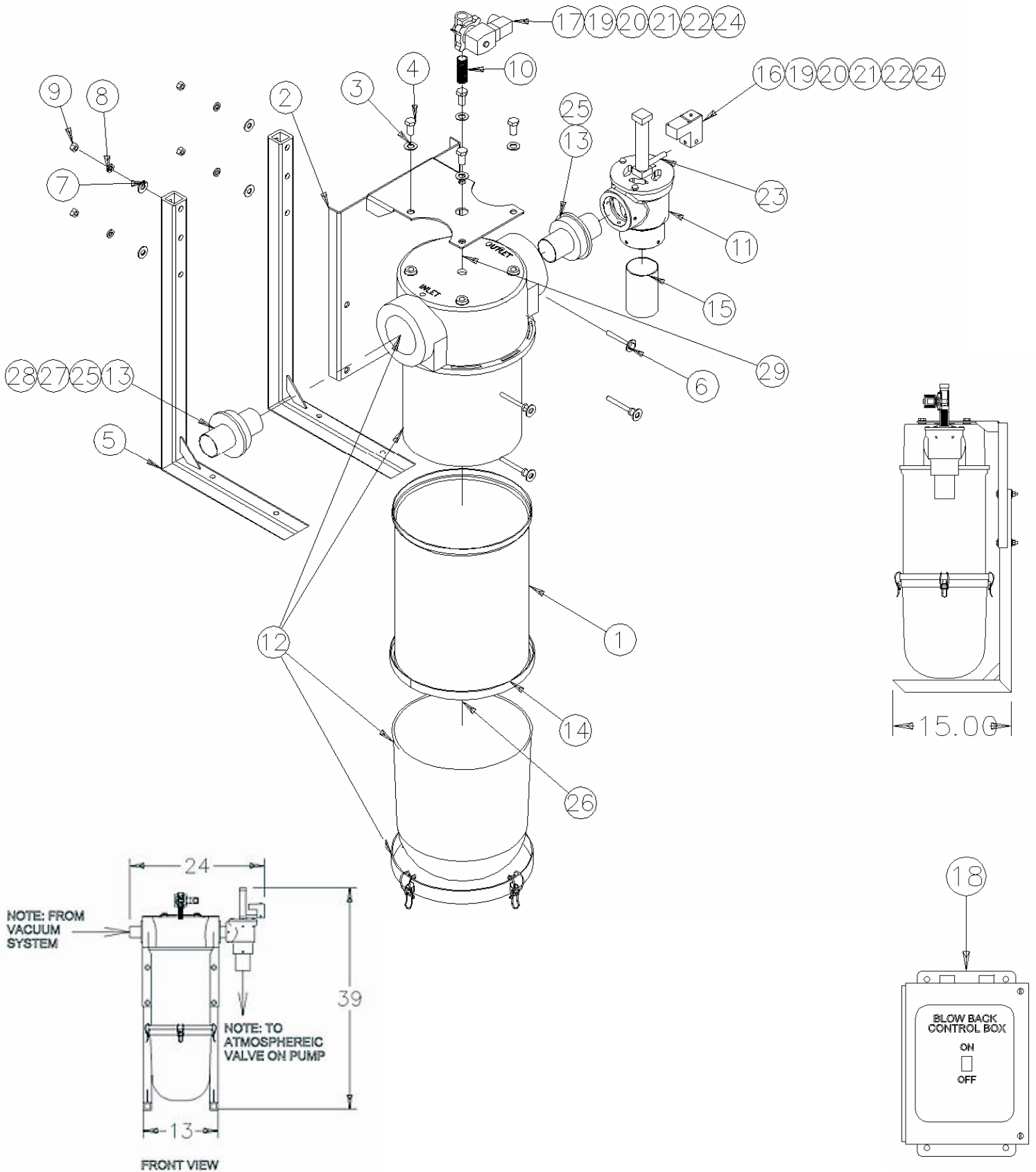

Figure 59: Vacuum Power Units; 25 to 30 hp (18.65-22.38 kW) Spare Parts List

Part number	Part description
W00018616	Air cylinder assembly and valve repair kit; for W00018080 upper valve
W00018617	Air cylinder assembly and valve repair kit; for W00018081 upper valve
W00017919	Air cylinder, lower valve
W00017918	Air cylinder, upper valve
W00018625	Air cylinder seal replacement kit; for W00017919 lower valve air cylinder
W00018626	Air cylinder seal replacement kit; for W00017918 upper valve air cylinder
W00016022	Belt, drive, 25 hp; 2 required
W00533012	Belt, drive, 30 hp; 2 required
W00054462	Bushing, blower; 25 hp units
W00052238	Bushing, blower; 30 hp units
W00016019	Bushing, motor; 25 hp and 30 hp units
W00001466	Clamp, hose; for 4½" ID hose
W00001142	Connector, 90 deg. elbow; for ¼" OD poly tube
W00001135	Connector, straight; for ¼" OD copper tube
W00013971	Connector, 90 deg.; for ¼" OD copper tube
W00012767	Connector, straight; for ¼" OD copper tube
W00012218	Elements, filter, inlet silencer
W00001043	Gauge, vacuum
W00018017	Gasket, valve; end cap mounting
W00018018	Gasket, air cylinder mounting
W00003246	Hose, rubber, 4½" ID x 4" long
W00051283	Silencer, horizontal
W00002353	Silencer, UH-4, vertical
W00003231	O-ring, 4½" ID x 4¾" OD x 1/8" thick
W00018016	O-ring, 8¼" ID x 8½" OD x 1/8" thick
W00018112	Plunger, upper and lower valves
W00013961	Regulator, air pressure
W00016288	Seal, valve air entrance fitting; Stat-O-Seal
W00002929	Screen, exhaust muffler
W00014988	Solenoid valve, 115 VAC, vacuum/vent
W00014987	Solenoid valve, 24 VDC, vacuum/vent
W00014659	Solenoid valve, 115 VAC, kay valve
W00014658	Solenoid valve, 24 VDC, kay valve
W00054463	Sheave, blower, less bushing; 25 hp
W00533127	Sheave, blower, less bushing; 30 hp
W00054461	Sheave, motor, less bushing; 25 hp
W00533128	Sheave, motor, less bushing; 30 hp
W00001174	Tubing, polyethylene, ¼" OD; per foot
W00005592	Tubing, copper, ¼" OD; per foot
A0547953	Vacuum switch, 14" Hg
W00018080	Valve assembly, lower
W00018081	Valve assembly, upper

Note: Refer to the Bill of Materials report included in the Customer Information Packet for a complete listing of parts.

Figure 60: SFC-S Filter



Note: Replacement filter element part number: A0571252.

Figure 61: SFC-S Filter Spare Parts List

*Note: Implosion blowback and compressed air blowback assemblies shown together.
Actual configuration depends on blowback method.*

List No.	Qty.	Part No.	Description
1	1	A0570026	EXTENSION CYLINDER
2	1	A0570051	BRKT, FLTR, MTG, SFC-S
3	4	A0069232	WASHER FLAT 1/2"
4	4	A0069236	SCR, HHC, PS, 1/2 - 13 X 1.00 LG
5	2	A0570013	STND, FLTR, BASE, WELDMNT
6	4	A0069230	SCR, HHC, PLD, 3/8 - 16X2 - 1/2, FT
7	8	A0069243	WASH, FLAT, WROUGHT, PLD, 3/8
8	4	A0069203	WASH, SPLIT, LOCK, 3/8
9	4	W00001491	NUT, HEX, PLD, 3/8-16
10	1	A0535382	NIP, BR, 0.50 NPT X 2.00 LG
11	1	W00050865	SUBASSY, AV 1.50
	1	W00018378	SUBASSY, AV 2.00
	1	W00050866	SUBASSY, AV 2.50
	1	W00050867	SUBASSY, AV 3.00
12	1	A0571249	FLTR, ASSY, 50 SQ. FT. AREA
13	2	A0559449	IN/OUT, SR008/16 AL, 1.50
	2	A0556518	IN/OUT, SR008/16 AL, 2.00
	2	A0556519	IN/OUT, SR008/16 AL, 2.50
	2	A0556520	IN/OUT, SR008/16 AL, 3.00
14	1	A0571316	GSKT, NAT, RBR, 5/16 THICK X 1/4 WIDE
15	1	A0571316	TUBE, 1.5" OD 4" LONG, ALUM
	1	A0570022	TUBE, 2.0" OD 4" LONG, ALUM
	1	A0570021	TUBE, 2.5" OD 4" LONG, ALUM
	1	A0571261	TUBE, 3" OD 4" LONG, ALUM
	1	A0555505	TBG, TRSN, AL, 3.00 OD - 3.50 OD
	1	A0555504	TBG, TRSN, AL, 3.00 OD - 4.00 OD
16	1	A0571250	SOLV, 3 WAY, 110v AC, 1/8 NPT
	1	A0571252	SOLV, 3 WAY, 24 V DC, 1/8 NPT
17	1	732.00012.02	VLV, SOL, 1/2", 5/8, GP, 300, 120V
	1	A0566361	VLV, SOL, 1/2", 5/8, GP, 300, 24VDC
18	1	A0571341	CNTL, BLOWBACK, SFC-S, 115V AC
	1	A0571342	CNTL, BLOWBACK, SFC-S, 24V DC
19	1	A0541039	STRF, STR, BLK, 1/2 NPT, .170 - .470
20	1	A0571348	CBL, 18-3C, 300V, SJEOW, BLK
21	1	A0563817	PATCHCD, DC, 4 CNDCT, 10M/32.2 FT
22	1	A0555194	PATCHCD, DC, RCPT, M, 12 IN LEAD
23	1	A0155502	NIP, CS, 0.13 NPT X 4.00 LG
24	1	A0565399	SOLV, DIN, CONN, 1/2" CONDUIT
25	2	A0556546	ORNG, SILC, 3.234 ID X 0.139 CS
26	1	A0069229	SPARE, BOLT, 3/8 - 16X2 LONG
27	1	A0559438	IN/OUT, SRX08-16, AL, 3.50
28	1	A0559447	IN/OUT, SRX08-16, AL, 4.00
29	1	A0541038	BOX, GANG, PLUG, 1/2" NPT

Figure 62: SPD Spare Parts Drawing

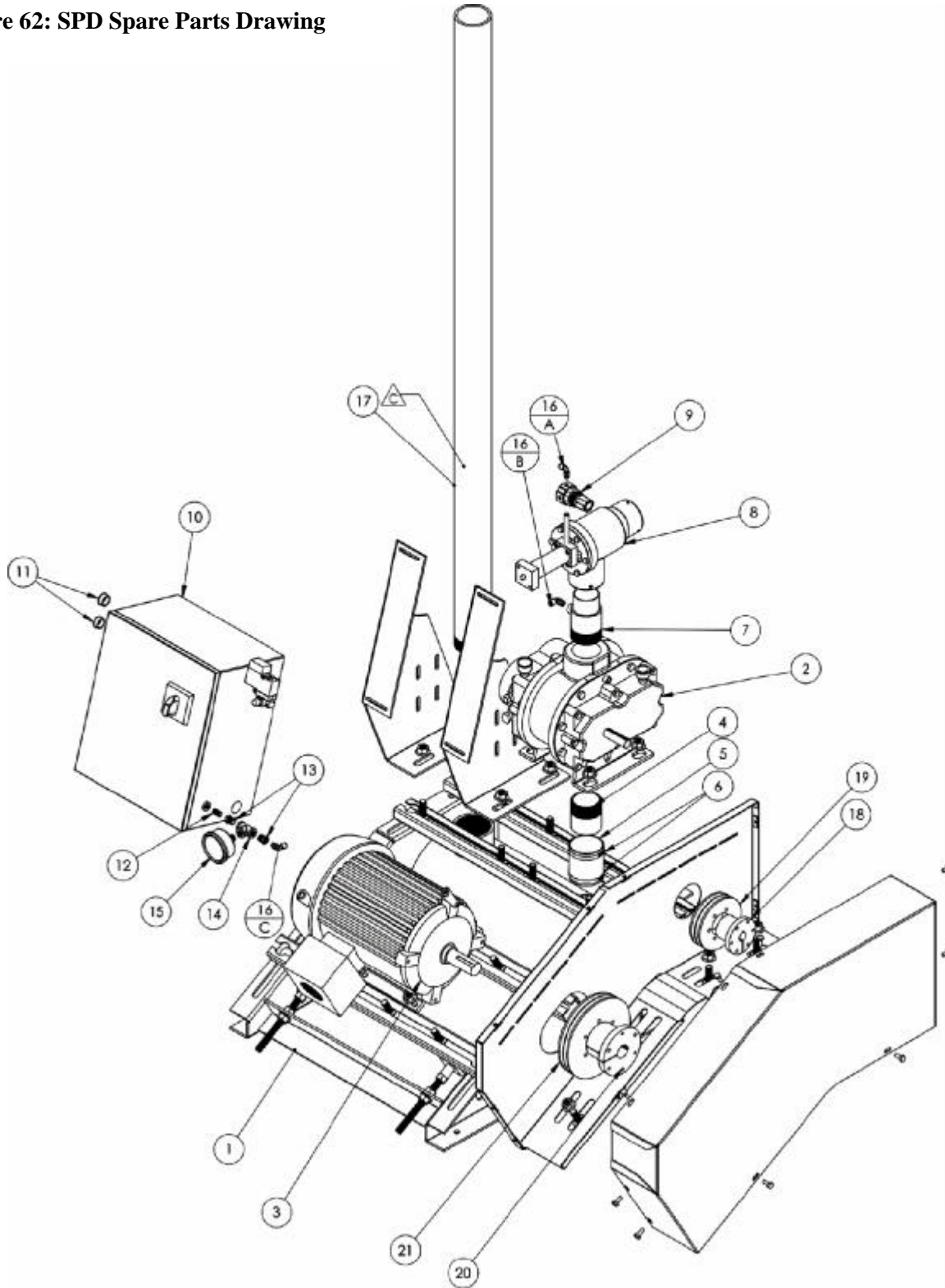

Figure 63: SPD Spare Parts List

(See previous pages for spare parts drawings)

List No.	Model No.	Qty.	Part No.	Description
1	SPD 5	1	A0571182	BLOWER
2	SPD 5	2	W00000145	O-RING
3	SPD 5	1	W00013524	VALVE PLUNGER
4	SPD 5	1	W00017811	VALVE GASKET
5	SPD 5	1	W00052176	MOTOR 5 HP 208/230/460 V
6	SPD 5	1	W00052800	MOTOR 5 HP 575 V
7	SPD 5	1	A0538247	MOTOR SHEAVE (60 HZ)
8	SPD 5	1	A0547083	MOTOR BUSHING (60 HZ)
9	SPD 5	1	A0538259	BLOWER SHEAVE (60 HZ)
10	SPD 5	1	A0573828	BLOWER BUSHING (60 HZ)
11	SPD 5	2	W00011500	PUMP BELT (60 HZ)
7	SPD 5	1	A0573834	MOTOR SHEAVE (50 HZ)
8	SPD 5	1	A0547083	MOTOR BUSHING (50 HZ)
9	SPD 5	1	A0538252	BLOWER SHEAVE (50 HZ)
10	SPD 5	1	W00052174	BLOWER BUSHING (50 HZ)
11	SPD 5	2	A0573868	PUMP BELT (50 HZ)
1	SPD 7.5	1	A0571183	BLOWER
2	SPD 7.5	1	W00017812	VALVE GASKET
3	SPD 7.5	1	W00001958	VALVE PLUNGER
4	SPD 7.5	2	W00001045	O-RING
5	SPD 7.5	1	W00052179	MOTOR 7.5 HP 208/230/460 V
6	SPD 7.5	2	W00052801	MOTOR 7.5 HP 575 V
7	SPD 7.5	1	A0573829	MOTOR SHEAVE (60 HZ)
8	SPD 7.5	1	W00011491	MOTOR BUSHING (60 HZ)
9	SPD 7.5	1	A0534549	BLOWER SHEAVE (60 HZ)
10	SPD 7.5	1	W00052178	BLOWER BUSHING (60 HZ)
11	SPD 7.5	2	W00011500	PUMP BELT (60 HZ)
7	SPD 7.5	1	A0538247	MOTOR SHEAVE (50 HZ)
8	SPD 7.5	1	W00054462	MOTOR BUSHING (50 HZ)
9	SPD 7.5	1	A0573945	BLOWER SHEAVE (50 HZ)
10	SPD 7.5	1	A0538249	BLOWER BUSHING (50 HZ)
11	SPD 7.5	2	W00011770	PUMP BELT (50 HZ)

Figure 63: SPD Spare Parts List (Cont'd)

List No.	Model No.	Qty.	Part No.	Description
1	SPD 10	1	A0571183	BLOWER
2	SPD 10	1	W00017812	VALVE GASKET
3	SPD 10	1	W00001958	VALVE PLUNGER
4	SPD 10	2	W00001045	O-RING
5	SPD 10	1	W00016464	MOTOR 10 HP 208/230/460 V
6	SPD 10	1	W00052802	MOTOR 10 HP 575 V
7	SPD 10-2.5 LINES	1	A0534550	MOTOR SHEAVE (60 HZ)
8	SPD 10-2.5 LINES	1	W00011491	MOTOR BUSHING (60 HZ)
9	SPD 10-2.5 LINES	1	A0538248	BLOWER SHEAVE (60 HZ)
10	SPD 10-2.5 LINES	1	A0538249	BLOWER BUSHING (60 HZ)
11	SPD 10-2.5 LINES	2	W00011500	PUMP BELT (60 HZ)
7	SPD 10-2.5 LINES	1	A0573834	MOTOR SHEAVE (50 HZ)
8	SPD 10-2.5 LINES	1	W00054462	MOTOR BUSHING (50 HZ)
9	SPD 10-2.5 LINES	1	A0538247	BLOWER SHEAVE (50 HZ)
10	SPD 10-2.5 LINES	1	A0547933	BLOWER BUSHING (50 HZ)
11	SPD 10-2.5 LINES	2	A0547043	PUMP BELT (50 HZ)
7	SPD 10-3.0 LINES	1	A0538247	MOTOR SHEAVE (60 HZ)
8	SPD 10-3.0 LINES	1	W00054462	MOTOR BUSHING (60 HZ)
9	SPD 10-3.0 LINES	1	A0538248	BLOWER SHEAVE (60 HZ)
10	SPD 10-3.0 LINES	1	A0538249	BLOWER BUSHING (60 HZ)
11	SPD 10-3.0 LINES	2	W00011500	PUMP BELT (60 HZ)
7	SPD 10-3.0 LINES	1	A0538258	MOTOR SHEAVE (50 HZ)
8	SPD 10-3.0 LINES	1	W00054462	MOTOR BUSHING (50 HZ)
9	SPD 10-3.0 LINES	1	A0538259	BLOWER SHEAVE (50 HZ)
10	SPD 10-3.0 LINES	1	W00052178	BLOWER BUSHING (50 HZ)
11	SPD 10-3.0 LINES	2	A0547043	PUMP BELT (50 HZ)
SPD 15				
1	SPD 15	1	A0571183	BLOWER
2	SPD 15	2	W00001738	O-RING
3	SPD 15	1	W00001958	VALVE GASKET
4	SPD 15	1	W00017812	VALVE PLUNGER
5	SPD 15	1	W00016466	MOTOR 15 HP 208/230/460 V
6	SPD 15	1	W00052803	MOTOR 15 HP 575 V
7	SPD 15-3.0 LINES	1	A0573834	MOTOR SHEAVE (60 HZ)
8	SPD 15-3.0 LINES	1	W00016479	MOTOR BUSHING (60 HZ)
9	SPD 15-3.0 LINES	1	A0534550	BLOWER SHEAVE (60 HZ)
10	SPD 15-3.0 LINES	1	W00052178	BLOWER BUSHING (60 HZ)
11	SPD 15-3.0 LINES	2	A0547043	PUMP BELT (60 HZ)
7	SPD 15-3.0 LINES	1	A0573829	MOTOR SHEAVE (60 HZ)
8	SPD 15-3.0 LINES	1	W00011495	MOTOR BUSHING (60 HZ)
9	SPD 15-3.0 LINES	1	A0534549	BLOWER SHEAVE (60 HZ)
10	SPD 15-3.0 LINES	1	W00052178	BLOWER BUSHING (60 HZ)
11	SPD 15-3.0 LINES	2	A0547043	PUMP BELT (60 HZ)
5	SPD 15-3.0 LINES	1	A0555870	MOTOR 15 HP 208/230/460 V (50 HZ ONLY)
6	SPD 15-3.0 LINES	1	A0555875	MOTOR 15 HP 575 V (50 HZ ONLY)
7	SPD 15-3.5 LINES	1	A0573834	MOTOR SHEAVE (60 HZ)
8	SPD 15-3.5 LINES	1	W00016479	MOTOR BUSHING (60 HZ)
9	SPD 15-3.5 LINES	1	A0573829	BLOWER SHEAVE (60 HZ)
10	SPD 15-3.5 LINES	1	W00052178	BLOWER BUSHING (60 HZ)
11	SPD 15-3.5 LINES	2	A0547043	PUMP BELT (60 HZ)
7	SPD 15-3.5 LINES	1	A0534550	MOTOR SHEAVE (60 HZ)
8	SPD 15-3.5 LINES	1	W00011495	MOTOR BUSHING (60 HZ)
9	SPD 15-3.5 LINES	1	A0534549	BLOWER SHEAVE (60 HZ)
10	SPD 15-3.5 LINES	1	W00052178	BLOWER BUSHING (60 HZ)
11	SPD 15-3.5 LINES	2	A0547043	PUMP BELT (60 HZ)
5	SPD 15-3.5 LINES	1	A0555870	MOTOR 15 HP 208/230/460 V (50 HZ ONLY)
6	SPD 15-3.5 LINES	1	A0555875	MOTOR 15 HP 575 V (50 HZ ONLY)

Figure 63: SPD Spare Parts List (Cont'd)

List No.	Model No.	Qty.	Part No.	Description
12	SPD 5/7.5/10/15	1	A0069307	POLY TUBING
13	SPD 5/7.5/10/15	1	A0547079	VACUUM GAUGE
14	SPD 5/7.5/10/15	1	35085K	STRAIGHT FITTING
15	SPD 5/7.5/10/15	1	35086K	ELBOW FITTING
16	SPD 5/7.5/10/15	1	A0543268	FTG, BR, BU, 0.25 NPT X 1/8 NPT
17	SPD 5/7.5/10/15	1	A0543269	FTG, BR, TE, 0.25 NPT
18	SPD 5/7.5/10/15	1	A0532231	NIP, BR, 0.25 NPT X 0.88 LG, CL
19	SPD 5/7.5/10/15	1	W00013961	AIR REGULATOR
20	SPD 5/7.5/10/15	1	W00017552	CYLINDER GASKET SEAL KIT
20	SPD 5/7.5/10/15	1	W00017688	AIR CYLINDER
21	SPD 5/7.5/10/15	1	A0571250	SOLENOID VALVE 3 WAY 115 VAC 1/8 NPT
21	SPD 5/7.5/10/15	1	A0571252	SOLENOID VALVE 3 WAY 24VDC 1/8 NPT
22	SPD 5/7.5/10/15	1	A0573982	SYNTHETIC OIL GALLON ISO-V-320
22	SPD 5/7.5/10/15	1	214.00002.00	SYNTHETIC OIL QUART ISO-VG-320
22	SPD 5/7.5/10/15	1	214.00004.00	SYNTHETIC OIL CASE ISO-VG-320
23	SPD 5/7.5/10/15	1	A0015492	NIPPLE FITTING
24	SPD 5/7.5/10/15	1	A0562421	CONDUIT FITTING STRAIGHT
25	SPD 5/7.5/10/15	1	A0562419	CONDUIT FITTING ELBOW
26	SPD 5/7.5/10/15	3 FT.	A0562430	CONDUIT FLEXIBLE

Figure 64: Reversing Valve Assembly Spare Parts Drawing

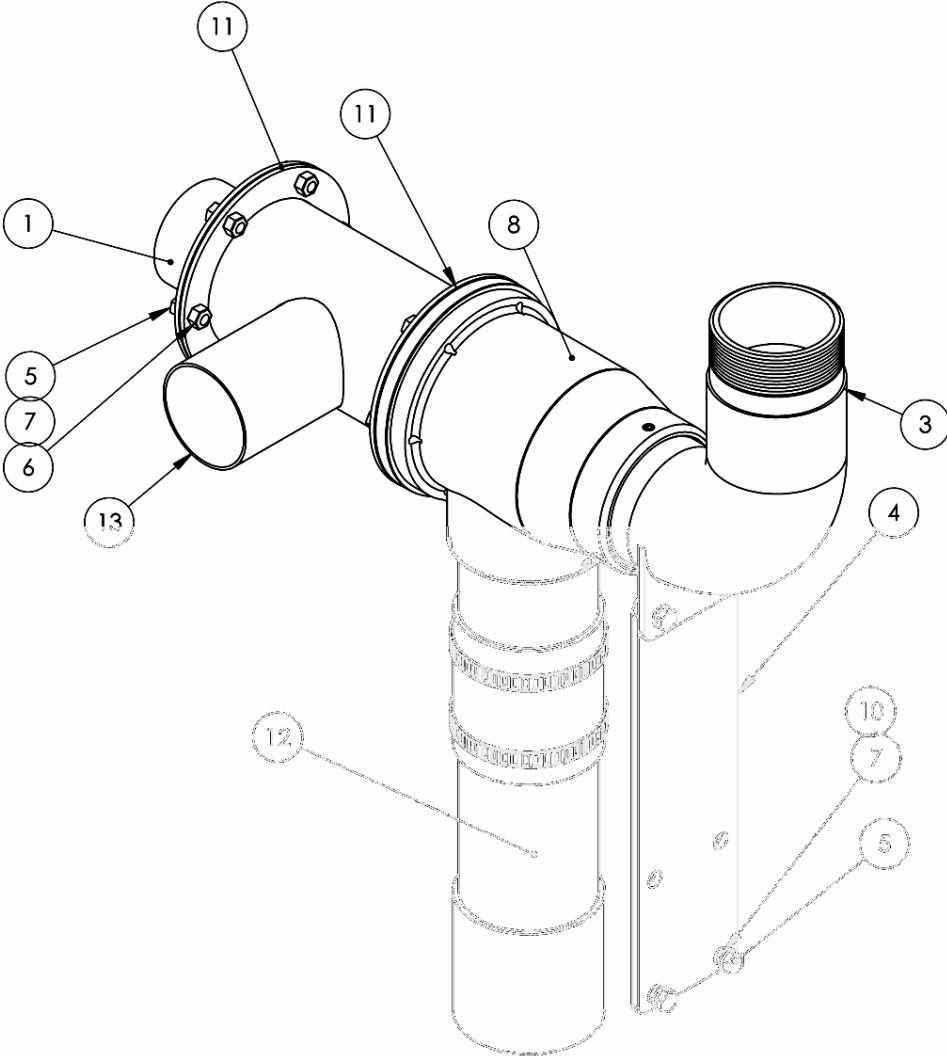

Figure 65: SPD Reversing Valve Option Spare Parts List

Item No.	Model No.	Qty.	Part No.	Description
1	SPD 5	1	A0573974	ADPTR, CS, 2.00 OD, XPD 5 W/BB
	SPD 7.5-10		A0573975	ADPTR, CS, 2.50 OD, XPD 7.5-10 W/BB
	SPD 15		A0573976	ADPTR, CS, 3.00 OD, XPD 15 W/BB
2	SPDB 5-15	1	A0573980	PIPE, DSCH, UPR, XPD 5-15 W/BB
3	SPD 5-15	1	A0573981	EL, AL, 3"OD X 2.5NPT, XPD 5-15 W/BB
4	SPD 5-15	1	A0573987	BRKT, SUPT, DSCH, XPD 5-15 HP W/BB
5	SPD 5-15	10	W00013527	SCR, HHC, PS, 1/4 -20 X 0.63LG
6	SPD 5-15	6	A0069206	NUT, HEX, PS, 1/4-20
7	SPD 5-15	10	A0101190	WSHR, LOCK, ¼
8	SPD 5-15	1	A0573983	VLV, ASSY, REV, XPD 5-15, 3" CONN
9	SPD 5-15	3	35086K	FTG, TBG, 90, 1/8NPT X 1/4TBG
10	SPD 5-15	4	A0553322	NUT, RVT, PS, 1/4-20
11	SPD 5-15	2	W00017812	GASKET
12	SPD 5	1	892.00305.00	PIPE, DSCH, LWR, XPD 5 W/BB
	SPD 7.5-15		892.00373.00	PIPE, DSCH, LWR, XPD 7.5-15 W/BB
13	SPD 5	1	A0573977	INL, VAC, 2.0 OD, XPD 5 W/BB
	SPD 7.5-10		A0573987	INL, VAC, 2.0 OD, XPD 5 W/BB
	SPD 15		A0573979	INC, VAC, 3.00 OD, XPD 10-3"/15 W/BB

Figure 66: SPDB Spare Parts Drawing

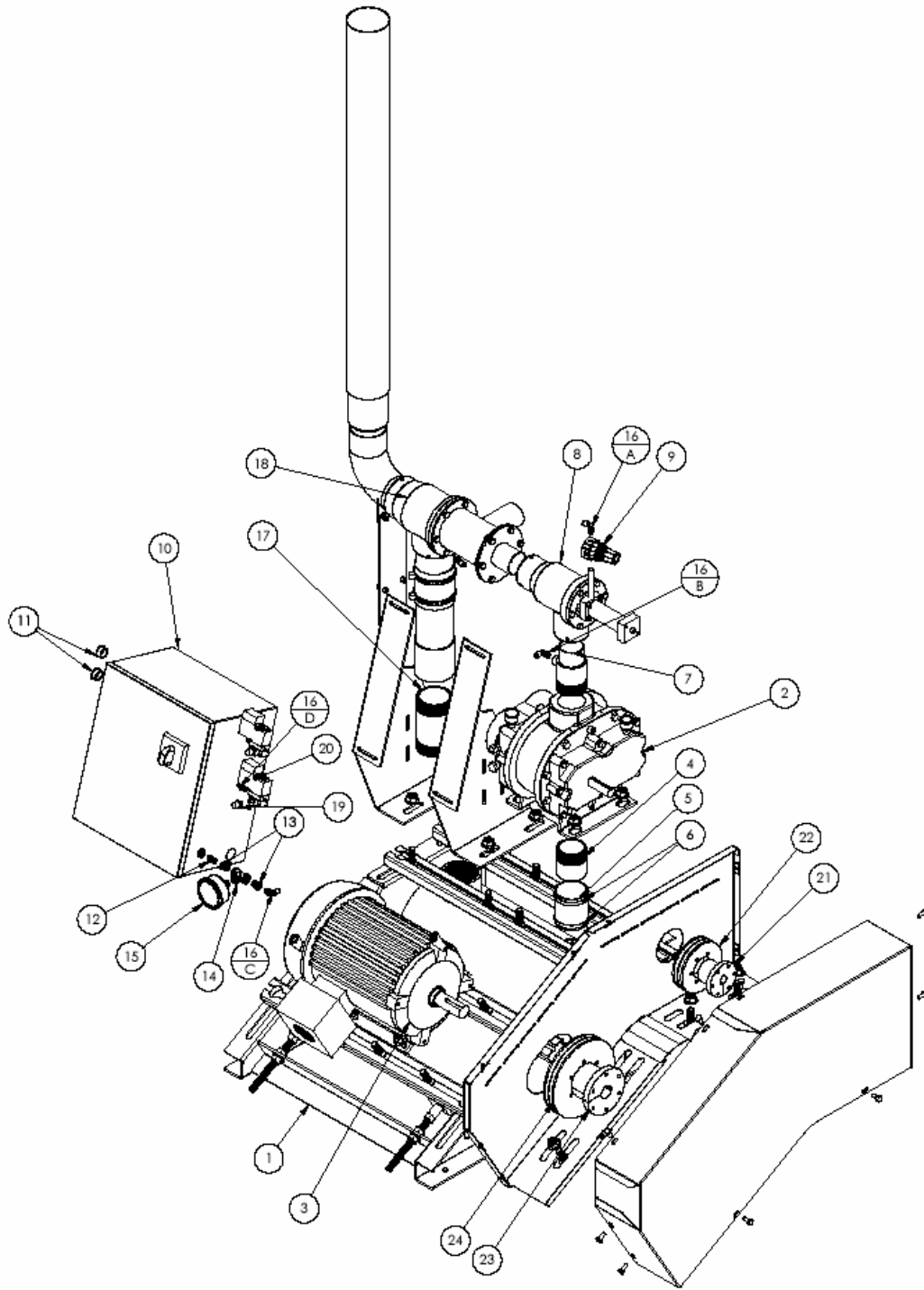

Figure 67: SPDB Spare Parts List

(See previous page for spare parts drawing)

Item No.	Model No.	Qty.	Part No.	Description
1	SPDB 5	1	228.00019.00	KIT, WELD, FRM, XPD 5HP, W/ HDWR
2	SPDB 5	1	A0571182	BLO, PD, 33URAIJ, HORT, 2.0NPT, LHD
3	SPDB 5	1	51119	MOTOR 5HP, 208-460 V (50 HZ)
			W00052176	MOTOR 5HP, 208-460 V (60HZ)
			W00052800	MOTOR 5HP, 575V
4	SPDB 5	1	A0573874	NIP, TOE, 2.0 NPT X 2.5
5	SPDB 5	1	A0573944	HOSE, FLEX, 2.5" ID X 3" LG
6	SPDB 5	2	W00000239	#44 HOSE CLAMP
7	SPDB 5	1	A0573316	ADPTR, CS, 2.0 NPT X 2.0 OD W/ 1/8 TAP
8	SPDB 5	1	W00018378	SUBASSY, AV 2.00
9	SPDB 5	1	W00013961	REG. AIR MINT 127111000 HPR LDR
10	SPDB 5	1	A0573824	J BOX 5HP, 115 VAC, 208/3/60 V
				J BOX 5HP, 115 VAC, 220/3/50 V
				J BOX 5HP, 115 VAC, 230/3/60 V
			A0573825	J BOX 5HP, 115 VAC, 400/3/50 V
				J BOX 5HP, 115 VAC, 460/3/60 V
				J BOX 5HP, 115 VAC, 575/3/60 V
			A0571619	J BOX 5HP, 24 VDC or DIST I/O, 208/3/60 V
				J BOX 5HP, 24 VDC or DIST I/O, 220/3/50 V
				J BOX 5HP, 24 VDC or DIST I/O, 230/3/60 V
			A0571662	J BOX 5HP, 24 VDC or DIST I/O, 400/3/50 V
J BOX 5HP, 24 VDC or DIST I/O, 460/3/60 V				
J BOX 5HP, 24 VDC or DIST I/O, 575/3/60 V				
11	SPDB 5	2	A0544752	PLUG, HOLE, DOME, BLK, 0.875 DIA
12	SPDB 5	1	A0538306	NIP, BR, 0.13 NPT X 0.75 LG, CLOSE
13	SPDB 5	2	A0543268	FTG, BR, BU, 1/4M X 1/8F
14	SPDB 5	1	A0543269	FTG, BR,TE, 1/4 x 1/4 x 1/4
15	SPDB 5	1	A0547079	GAUG, VAC, 2.5D, 0-30", 1/4 LM, GF, LWR, MNT SS
16	SPDB 5	4	35086K	FTG, TBG, 90, 1/8 NPT X 1/4 TBG
17	SPDB 5	1	A0015081	NIP, CS, 2.50 NPT X 5.0 OAL
18	SPDB 5	1	A0573984	GRP, XPD 5, BB VLV MECH PTS
19	SPDB 5	1	35157	MUFFLER, 1/8" NPT
20	SPDB 5	1	A0571252	SOLENOID VALVE – 24 VDC
			A0571250	SOLENOID VALVE – 120 VAC
21	SPDB 5	1	A0573828	5HP, BLOWER BUSHING (50HZ)
				5HP, BLOWER BUSHING (60HZ)
22	SPDB 5	1	A0534550	5HP, BLOWER SHEAVE (50HZ)
			A0538259	5HP, BLOWER SHEAVE (60HZ)
23	SPDB 5	1	W00011494	5HP, MOTOR BUSHING (50HZ)
			A0547083	5HP, MOTOR BUSHING (60HZ)
24	SPDB 5	1	A0538252	5HP, MOTOR SHEAVE (50HZ)
			A0538247	5HP, MOTOR SHEAVE (60HZ)
25	SPDB 5	2	W00011500	5HP, PUMP BELT (50 HZ) – NOT SHOWN
				5HP, PUMP BELT (60HZ) – NOT SHOWN
1	SPDB 7.5	1	228.00018.00	KIT, WELD, FRM, XPD, 7.5 – 15 HP
2	SPDB 7.5	1	A0571183	BLO, PD, 45URAIJ, HORT, 2.5 NPT, LHD
3	SPDB 7.5	1	W00052179	MOTOR 7.5HP, 208-460 V (50 HZ)
			W00052801	MOTOR 7.5HP, 208-460 V (60HZ)
4	SPDB 7.5	1	A0573315	NIP, TOE, 2.5 NPT X 3.0
5	SPDB 7.5	1	A0573944	HOSE, FLEX, 3.0" ID X 3 LG
6	SPDB 7.5	2	W00000239	#44 HOSE CLAMP
7	SPDB 7.5	1	A0573316	ADPTR, CS, 2.5 NPT X 2.5 OD. W/ 1/8 TAP
8	SPDB 7.5	1	W00050866	SUBASSY, AV 2.50
9	SPDB 7.5	1	W00013961	REG, AIR MINT 127111000 HPR LD

Figure 67: SPDB Spare Parts List (Cont'd.)

10	SPDB 7.5	1	A0573826	J BOX 7.5HP, 115 VAC, 208/3/60 V
				J BOX 7.5HP, 115 VAC, 220/3/50 V
				J BOX 7.5HP, 115 VAC, 230/3/60 V
			A0573824	J BOX 7.5HP, 115 VAC, 400/3/50 V
				J BOX 7.5HP, 115 VAC, 460/3/60 V
				J BOX 7.5HP, 115 VAC, 575/3/60 V
			A0571620	J BOX 7.5HP, 24 VDC or DIST I/O, 208/3/60 V
				J BOX 7.5HP, 24 VDC or DIST I/O, 220/3/50 V
				J BOX 7.5HP, 24 VDC or DIST I/O, 230/3/60 V
			A0571619	J BOX 7.5HP, 24 VDC or DIST I/O, 400/3/50 V
				J BOX 7.5HP, 24 VDC or DIST I/O, 460/3/60 V
				J BOX 7.5HP, 24 VDC or DIST I/O, 575/3/60 V
11	SPDB 7.5	2	A0544752	PLUG, HOLE, DOME, BLK, 0.875 DIA
12	SPDB 7.5	1	A0538306	NIP, BR, 0.13 NPT X 0.75 LG, CLOSE
13	SPDB 7.5	2	A0543268	FIG, BR, BU, 1/4M X 1/8F
14	SPDB 7.5	1	A0543269	FTG, BR,TE, 1/4 x 1/4 x 1/4
15	SPDB 7.5	1	A0547079	GAUG, VAC, 2.5D, 0-30", ¼ LM, GF, LWR, MNT SS
16	SPDB 7.5	4	35086K	FTG, TBG, 90, 1/8 NPT X 1/4 TBG
17	SPDB 7.5	1	A0015081	NIP, CS, 2.50 NPT X 5.0 OAL
18	SPDB 7.5	1	A0573985	GRP, XPD 7.5-10, BB VLV MECH PTS
19	SPDB 7.5	1	35157	MUFFLER, 1/8" NPT
20	SPDB 7.5	1	A0571252	SOLENOID VALVE – 24 VDC
			A0571250	SOLENOID VALVE – 120 VAC
21	SPDB 7.5	1	W00052178	7.5HP, BLOWER BUSHING (50HZ)
				7.5HP, BLOWER BUSHING (60HZ)
22	SPDB 7.5	1	A0573829	7.5HP, BLOWER SHEAVE (50HZ)
			A0534549	7.5HP, BLOWER SHEAVE (60HZ)
23	SPDB 7.5	1	W00054462	7.5HP, MOTOR BUSHING (50HZ)
			W00011491	7.5HP, MOTOR BUSHING (60HZ)
24	SPDB 7.5	1	A0538247	7.5HP, MOTOR SHEAVE (50HZ)
			A0573829	7.5HP, MOTOR SHEAVE (60HZ)
25	SPDB 7.5	2	W00011770	7.5HP, PUMP BELT (50 HZ) – <i>NOT SHOWN</i>
			W00011500	7.5HP, PUMP BELT (60HZ) – <i>NOT SHOWN</i>
1	SPDB 10	1	228.00018.00	KIT, WELD, FRM, XPD, 7.5 – 15 HP
2	SPDB 10	1	A0571183	BLO, PD, 45URAIJ, HORT, 2.5 NPT, LHD
3	SPDB 10	1	A0504633	MOTOR 10HP – 2.5", 208-460 V (50 HZ)
			W00016464	MOTOR 10HP – 2.5", 208-460 V (60 HZ)
			W00052802	MOTOR 10HP – 2.5", 575 V
			W00016464	MOTOR 10HP – 3.0", 208-460
				MOTOR 10HP – 3.0", 208-460 V (60 HZ)
W00052802	MOTOR 10HP – 3.0", 575 V			
4	SPDB 10	1	A0573315	NIP, TOE, 2.5 NPT X 3.0
5	SPDB 10	1	A0573944	HOSE, FLEX, 3.0" ID X 3 LG
6	SPDB 10	2	W00000239	#44 HOSE CLAMP
7	SPDB 10	1	A0573316	ADPTR, CS, 2.5 NPT X 2.5 OD. W/ 1/8 TAP
8	SPDB 10	1	W00050866	SUBASSY, AV 2.50
9	SPDB 10	1	W00013961	REG, AIR MINT 127111000 HPR LDR

Figure 67: SPDB Spare Parts List (Cont'd.)

10	SPDB 10	1	A0573826	J BOX 10HP, 115 VAC, 208/3/60 V
				J BOX 10HP, 115 VAC, 220/3/50 V
				J BOX 10HP, 115 VAC, 230/3/60 V
			A0573824	J BOX 10HP, 115 VAC, 400/3/50 V
				J BOX 10HP, 115 VAC, 460/3/60 V
				J BOX 10HP, 115 VAC, 575/3/60 V
			A0571620	J BOX 10HP, 24 VDC or DIST I/O, 208/3/60 V
				J BOX 10HP, 24 VDC or DIST I/O, 220/3/50 V
				J BOX 10HP, 24 VDC or DIST I/O, 230/3/60 V
			A0571619	J BOX 10HP, 24 VDC or DIST I/O, 400/3/50 V
				J BOX 10HP, 24 VDC or DIST I/O, 460/3/60 V
				J BOX 10HP, 24 VDC or DIST I/O, 575/3/60 V
11	SPDB 10	2	A0544752	PLUG, HOLE, DOME, BLK, 0.875 DIA
12	SPDB 10	1	A0538306	NIP, BR, 0.13 NPT X 0.75 LG, CLOSE
13	SPDB 10	2	A0543268	FIG, BR, BU, 1/4M X 1/8F
14	SPDB 10	1	A0543269	FTG, BR,TE, 1/4 x 1/4 x 1/4
15	SPDB 10	1	A0547079	GAUG, VAC, 2.5D, 0-30", ¼ LM, GF, LWR, MNT SS
16	SPDB 10	4	35086K	FTG, TBG, 90, 1/8 NPT X 1/4 TBG
17	SPDB 10	1	A0015081	NIP, CS, 2.50 NPT X 5.0 OAL
18	SPDB 10	1	A0573985	GRP, XPD 7.5-10, BB VLV MECH PTS
19	SPDB 10	1	35157	MUFFLER, 1/8" NPT
20	SPDB 10	1	A0571252	SOLENOID VALVE – 24 VDC
			A0571250	SOLENOID VALVE – 120 VAC
21	SPDB 10	1	A0547933	10HP – 2.5" LINE, BLOWER BUSHING (50HZ)
			A0538249	10HP – 2.5" LINE, BLOWER BUSHING (60HZ)
			W00052178	10HP – 3.0" LINE, BLOWER BUSHING (50HZ)
			A0538294	10HP – 3.0" LINE, BLOWER BUSHING (60HZ)
22	SPDB 10	1	A0538247	10HP – 2.5" LINE, BLOWER SHEAVE (50HZ)
			A0538248	10HP – 2.5" LINE, BLOWER SHEAVE (60HZ)
			A0538259	10HP – 3.0" LINE, BLOWER SHEAVE (50HZ)
			A0538248	10HP – 3.0" LINE, BLOWER SHEAVE (60HZ)
23	SPDB 10	1	W00011491	10HP – 2.5", MOTOR BUSHING (50HZ)
				10HP – 2.5", MOTOR BUSHING (60HZ)
			W00054462	10HP – 3.0", MOTOR BUSHING (50HZ)
				10HP – 3.0", MOTOR BUSHING (60HZ)
24	SPDB 10	1	A0573829	10HP – 2.5", MOTOR SHEAVE (50HZ)
			A0534550	10HP – 2.5", MOTOR SHEAVE (60HZ)
			A0538258	10HP – 3.0", MOTOR SHEAVE (50HZ)
			A0538247	10HP – 3.0", MOTOR SHEAVE (60HZ)
25	SPDB 10	1	W00011770	10HP – 2.5" LINE, PUMP BELT (50 HZ) – <i>NOT SHOWN</i>
			W00011500	10HP – 2.5" LINE, PUMP BELT (60HZ) – <i>NOT SHOWN</i>
			A0547043	10HP – 3.0" LINE, PUMP BELT (50 HZ) – <i>NOT SHOWN</i>
			W00011500	10HP – 3.0" LINE, PUMP BELT (60HZ) – <i>NOT SHOWN</i>
1	SPDB 15	1	228.00018.00	KIT, WELD, FRM, XPD, 7.5 – 15 HP
2	SPDB 15	1	A0571183	BLO, PD, 45URAIJ, HORT, 2.5 NPT, LHD
3	SPDB 15	1	A0555870	MOTOR 15HP – 3.0", 208-460 V (50 HZ)
			W00016466	MOTOR 15HP – 3.0", 208-460 v (60 HZ)
			W00052803	MOTOR 15HP – 3.0", 575 V
			A0555870	MOTOR 15HP – 3.5", 208-460 V (50 HZ)
			W00016466	MOTOR 15HP – 3.5", 208-460 V (60 HZ)
			W00052803	MOTOR 15HP – 3.5", 575 V
4	SPDB 15	1	A0573315	NIP, TOE, 2.5 NPT X 3.0
5	SPDB 15	1	A0573944	HOSE, FLEX, 3.0" ID X 3 LG
6	SPDB 15	2	W00000239	#44 HOSE CLAMP
7	SPDB 15	1	A0573317	ADPTR, CS, 2.5 NPT X 3.0 OD, W/ 1/8 TAP
8	SPDB 15	1	W00050867	SUBASSY, AV 3.00
9	SPDB 15	1	W00013961	REG, AIR MINT 127111000 HPR LDR

Figure 67: SPDB Spare Parts List (Cont'd.)

10	SPDB 15	1	A0573827	J BOX 15HP, 115 VAC, 208/3/60 V
				J BOX 15HP, 115 VAC, 220/3/50 V
				J BOX 15HP, 115 VAC, 230/3/60 V
			A0573826	J BOX 15HP, 115 VAC, 400/3/50 V
				J BOX 15HP, 115 VAC, 460/3/60 V
				J BOX 15HP, 115 VAC, 575/3/60 V
			A0571621	J BOX 15HP, 24 VDC or DIST I/O, 208/3/60 V
				J BOX 15HP, 24 VDC or DIST I/O, 220/3/50 V
				J BOX 15HP, 24 VDC or DIST I/O, 230/3/60 V
			A0571620	J BOX 15HP, 24 VDC or DIST I/O, 400/3/50 V
				J BOX 15HP, 24 VDC or DIST I/O, 460/3/60 V
				J BOX 15HP, 24 VDC or DIST I/O, 575/3/60 V
11	SPDB 15	2	A0544752	PLUG, HOLE, DOME, BLK, 0.875 DIA
12	SPDB 15	1	A0538306	NIP, BR, 0.13 NPT X 0.75 LG, CLOSE
13	SPDB 15	2	A0543268	FIG, BR, BU, 1/4M X 1/8F
14	SPDB 15	1	A0543269	FTG, BR,TE, 1/4 x 1/4 x 1/4
15	SPDB 15	1	A0547079	GAUG, VAC, 2.5D, 0-30", ¼ LM, GF, LWR, MNT SS
16	SPDB 15	4	35086K	FTG, TBG, 90, 1/8 NPT X 1/4 TBG
17	SPDB 15	1	A0015081	NIP, CS, 2.50 NPT X 5.0 OAL
18	SPDB 15	1	A0573986	GRP, XPD 15, BB VLV MECH PITS
19	SPDB 15	1	35157	MUFFLER, 1/8" NPT
20	SPDB 15	1	A0571252	SOLENOID VALVE – 24 VDC
			A0571250	SOLENOID VALVE – 120 VAC
21	SPDB 15	1	W00052178	15HP – 3.0" LINE, BLOWER BUSHING (50HZ)
				15HP – 3.0" LINE, BLOWER BUSHING (60HZ)
				15HP – 3.5" LINE, BLOWER BUSHING (50HZ)
				15HP – 3.5" LINE, BLOWER BUSHING (60HZ)
22	SPDB 15	1	A0534549	15HP – 3.0" LINE, BLOWER SHEAVE (50HZ)
			A0534550	15HP – 3.0" LINE, BLOWER SHEAVE (60HZ)
			A0573829	15HP – 3.5" LINE, BLOWER SHEAVE (50HZ)
			A0573829	15HP – 3.5" LINE, BLOWER SHEAVE (60HZ)
23	SPDB 15	1	W0011495	15HP – 3.0", MOTOR BUSHING (50HZ)
			22012M	15HP – 3.0", MOTOR BUSHING (60HZ)
			W011495	15HP – 3.5", MOTOR BUSHING (50HZ)
			22012M	15HP – 3.5", MOTOR BUSHING (60HZ)
24	SPDB 15	1	A0573829	15HP – 3.0", MOTOR SHEAVE (50HZ)
			23012M	15HP – 3.0", MOTOR SHEAVE (60HZ)
			A0534549	15HP – 3.5", MOTOR SHEAVE (50HZ)
			23012M	15HP – 3.5", MOTOR SHEAVE (60HZ)
25	SPDB 15	2	A0547043	15HP – 3.0" LINE, PUMP BELT (50 HZ) – <i>NOT SHOWN</i>
				15HP – 3.0" LINE, PUMP BELT (60HZ) – <i>NOT SHOWN</i>
				15HP – 3.5" LINE, PUMP BELT (50 HZ) – <i>NOT SHOWN</i>
				15HP – 3.5" LINE, PUMP BELT (60HZ) – <i>NOT SHOWN</i>

Figure 68: SPC Spare Parts Drawing

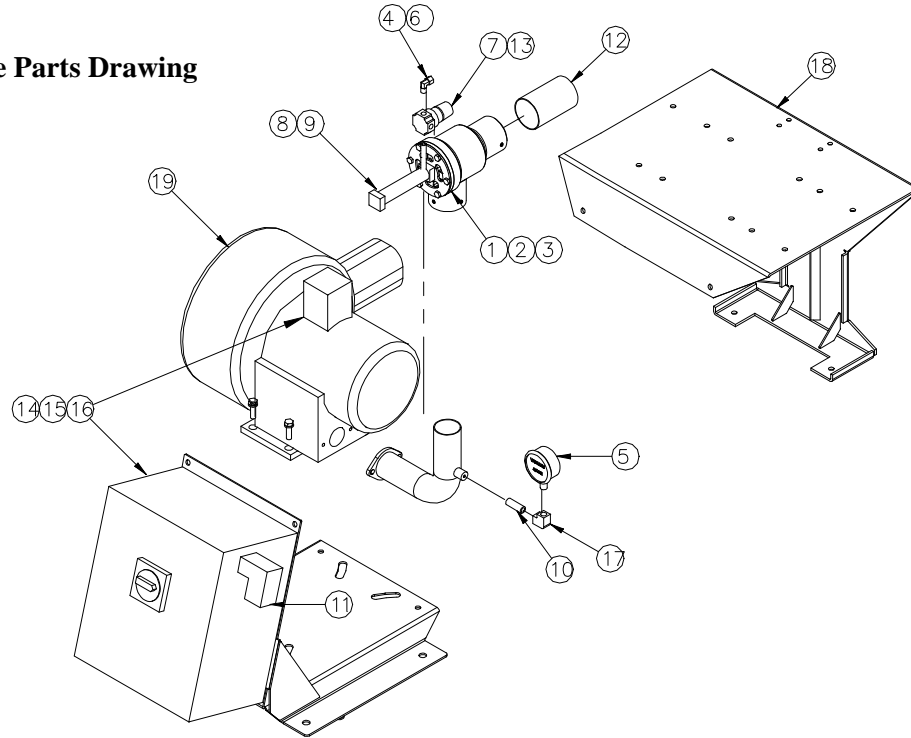

Figure 69: Centrifugal Vacuum Pump Spare Parts List

List #	Model #	Qty.	Part #	Description
1	SPC 3.5/6.5	1	W00000145	O-RING
2	SPC 3.5/6.5	1	W00013524	VALVE PLUNGER
3	SPC 3.5/6.5	1	W00017811	VALVE GASKET
4	SPC 3.5/6.5/11	1	A0069307	AIR TUBING
5	SPC 3.5/6.5/11	1	A0547079	VACUUM GAUGE
6	SPC 3.5/6.5/11	1	35086K	TUBING ELBOW
7	SPC 3.5/6.5/11	1	W00013961	AIR REGULATOR
8	SPC 3.5/6.5/11	1	W00017552	CYLINDER SEAL KIT
9	SPC 3.5/6.5/11	1	W00017688	AIR CYLINDER
10	SPC 3.5/6.5/11	1	A0535380	BRASS NIPPLE .25NPT X 1.5 LG
11	SPC 3.5/6.5/11	1	A0571250	SOLENOID VALVE 3WAY 115 VAC 1/8NPT
11	SPC 3.5/6.5/11	1	A0571252	SOLENOID VALVE 3WAY 24 VDC 1/8NPT
12	SPC 3.5/6.5/11	1	W00000334	HOSE CLAMP
13	SPC 3.5/6.5/11	1	A0015492	NIPPLE FITTING
14	SPC 3.5/6.5/11	1	A0562421	CONDUIT FITTING STRAIGHT
15	SPC 3.5/6.5/11	1	A0562419	CONDUIT FITTING ELBOW
16	SPC 3.5/6.5/11	3 FT.	A0562430	CONDUIT FLEXIBLE
17	SPC 3.5/6.5/11	1	35193	BRASS ELBOW ¼ NPT
18	SPC 3.5/6.5/11	1	A0570035	FILTER MOUNTING ADAPTER
19	SPC 3.5	1	A0570037	BLOWER 3.5 HP 208-460 V
19	SPC 3.5	1	A0570030	BLOWER 3.5 HP 575 V
19	SPC 6.5	1	A0570038	BLOWER 5 HP 208-460 V
19	SPC 6.5	1	A0570033	BLOWER 5 HP 575 V
19	SPC 11	1	A0570039	BLOWER 11.5 HP 208-460 V
19	SPC 11	1	A0570040	BLOWER 11.5 HP 575 V
1	SPC 11	1	W00001045	O-RING
2	SPC 11	1	W00001958	VALVE PLUNGER
3	SPC 11	1	W00017812	VALVE GASKET

-Notes-

7-5 Technical Assistance

Parts Department

Call toll-free 7am–5pm CST [800] 423-3183 or call [262] 641-8600, Fax [262] 641-8653

The ACS Customer Service Group will provide your company with genuine OEM quality parts manufactured to engineering design specifications, which will maximize your equipment's performance and efficiency. To assist in expediting your phone or fax order, please have the model and serial number of your unit when you contact us. A customer replacement parts list is included in this manual for your convenience. ACS welcomes inquiries on all your parts needs and is dedicated to providing excellent customer service.

Service Department

Call toll-free 8am–5pm CST [800] 423-3183 or call [262] 641-8600

Emergencies after 5pm CST, call [800] 423-3183

We have a qualified service department ready to help. Service contracts are available for most products.

Sales Department

Call [262] 641-8600 Monday–Friday, 8am–5pm CST

Our products are sold by a world-wide network of independent sales representatives. Contact our Sales Department for the name of the sales representative nearest you.

Contract Department

Call [262] 641-8600 Monday–Friday, 8am–5pm CST

Let us install your system. The Contract Department offers any or all of these services: project planning; system packages including drawings; equipment, labor, and construction materials; and union or non-union installations.

Free Manuals Download Website

<http://myh66.com>

<http://usermanuals.us>

<http://www.somanuals.com>

<http://www.4manuals.cc>

<http://www.manual-lib.com>

<http://www.404manual.com>

<http://www.luxmanual.com>

<http://aubethermostatmanual.com>

Golf course search by state

<http://golfingnear.com>

Email search by domain

<http://emailbydomain.com>

Auto manuals search

<http://auto.somanuals.com>

TV manuals search

<http://tv.somanuals.com>