

## Operating Instructions

### Conveyor Hopper with blower-filter unit SGFE

## Please note that our address and phone information has changed. Please reference this page for updated contact information.



These manuals are obsolete and are provided only for their technical information, data and capacities. Portions of these manuals detailing procedures or precautions in the operation, inspection, maintenance and repair of the products may be inadequate, inaccurate, and/or incomplete and shouldn't be relied upon. Please contact the ACS Group for more current information about these manuals and their warnings and precautions.

### Parts and Service Department

The ACS Customer Service Group will provide your company with genuine OEM quality parts manufactured to engineering design specifications, which will maximize your equipment's performance and efficiency. To assist in expediting your phone or fax order, please have the model and serial number of your unit when you contact us. A customer replacement parts list is included in this manual for your convenience. ACS welcomes inquiries on all your parts needs and is dedicated to providing excellent customer service.

#### For immediate assistance, please contact:

- North, Central and South America, 8am – 5pm CST +1 (800) 483-3919 for drying, conveying, heating and cooling and automation. For size reduction: +1 (800) 229-2919.  
North America, emergencies after 5pm CST (847) 439-5855  
**North America email: [acsuscanadacustserv@corpemail.com](mailto:acsuscanadacustserv@corpemail.com)**
- Mexico, Central & South America  
**Email: [acslatinamericacustserv@corpemail.com](mailto:acslatinamericacustserv@corpemail.com)**
- Europe, Middle East & Africa +48 22 390 9720  
**Email: [acseuropecustserv@corpemail.com](mailto:acseuropecustserv@corpemail.com)**
- India +91 21 35329112  
**Email: [acsindiacustserv@corpemail.com](mailto:acsindiacustserv@corpemail.com)**
- Asia/Australia +86 512 8717 1919  
**Email: [acsasiacustserv@corpemail.com](mailto:acsasiacustserv@corpemail.com)**

### Sales and Contracting Department

Our products are sold by a worldwide network of independent sales representatives. Contact our Sales Department for the name of the sales representative nearest you.

Let us install your system. The Contract Department offers any or all of these services: project planning; system packages including drawings; equipment, labor, and construction materials; and union or non-union installations.

#### For assistance with your sales or system contracting needs please Call:

North, Central and South America +1 (262) 641-8600 or +1 (847) 273-7700 Monday–Friday, 8am–5pm CST

Europe/Middle East/Africa +48 22 390 9720

India +91 21 35329112

Asia/Australia +86 512 8717 1919

#### Facilities:

ACS offers facilities around the world to service you no matter where you are located. For more information, please visit us at [www.acscorporate.com](http://www.acscorporate.com)

United States:

#### ACS Schaumburg – Corporate Offices

1100 E. Woodfield Road  
Suite 588  
Schaumburg, IL 60173  
Phone: + 1 847 273 7700  
Fax: + 1 847 273 7804

#### ACS New Berlin – Manufacturing Facility

2900 S. 160<sup>th</sup> Street  
New Berlin, WI 53151  
Phone : +1 262 641 8600  
Fax: + 1 262 641 8653

Asia/Australia:

#### ACS Suzhou

109 Xingpu Road SIP  
Suzhou, China 215126  
Phone: + 86 8717 1919  
Fax: +86 512 8717 1916

Europe/Middle East/Africa:

#### ACS Warsaw

Ul. Działkowa 115  
02-234 Warszawa  
Phone: + 48 22 390 9720  
Fax: +48 22 390 9724

India

#### ACS India

Gat No. 191/1, Sandbhor Complex  
Mhalunge, Chakan, Tal Khed,  
Dist. Pune 410501, India  
Phone: +91 21 35329112  
Fax: + 91 20 40147576

**Sterling Material Processing**

5200 West Clinton Ave.

Milwaukee, WI 53223

Telephone: (414) 354-0970

Fax: (414) 354-6421

www.sterlco.com

**Technical service:**

Service department

Telephone: (800) 423-3183

**Edition: 10/01**

These operating instructions are for:\*

(\* Please fill in personally)

Serial number: \_\_\_\_\_

Built in: \_\_\_\_\_

Date of delivery: \_\_\_\_\_

Number of delivery: \_\_\_\_\_

Date of commissioning: \_\_\_\_\_

Location: \_\_\_\_\_

Group of machines: \_\_\_\_\_

SMA-618

Sterling Material Processing retains all rights to change the information in these operating instructions at any time without notice.

We assume no liability for any errors or direct or indirect damage resulting in context with these operating instructions.

Copying, translation or publication in any form except for personal use of purchaser requires approval from Sterling Material Processing.

All rights reserved.

---

## Table of contents

<b>1. Safety instructions</b> .....	<b>1-1</b>
1.1. General.....	1-1
1.2. For your safety.....	1-2
1.3. For the operating safety of the equipment .....	1-5
<b>2. Concerning these Operating Instructions</b> .....	<b>2-1</b>
2.1. General Information.....	2-1
2.2. Warning Messages and Symbols .....	2-2
2.3. Explanations and Definitions.....	2-3
2.4. Notes on Usage .....	2-4
<b>3. Start-up</b> .....	<b>3-1</b>
3.1. General.....	3-1
3.2. Control system .....	3-2
3.2.1. Operation .....	3-2
3.2.2. Key assignment .....	3-3
3.3. Switching on the control system .....	3-3
3.4. Setting the basic parameters .....	3-4
3.5. Starting the conveying procedure .....	3-7
3.6. The first conveying operations .....	3-7
3.7. Viewing Alarm Messages .....	3-8
3.8. Switching off the unit .....	3-9
<b>4. Maintenance</b> .....	<b>4-1</b>
4.1. General.....	4-1
4.2. Maintenance schedule.....	4-3
4.3. Checking the direction of rotation of the vacuum generator ...	4-5
4.4. Testing the conduit system .....	4-6
4.5. Adjusting the suction tube .....	4-7
4.6. Cleaning/replacing the filter cartridge.....	4-8
4.7. Servicing the accessories .....	4-9

<b>5. Assembly instructions</b> .....	<b>5-1</b>
5.1. Transport .....	5-2
5.2. Installation .....	5-2
5.3. Material feed .....	5-2
5.4. Suction pipe .....	5-3
5.5. Pipework .....	5-4
5.6. Vacuum generator .....	5-5
5.6.1. Rotary lobe vacuum pump GDK .....	5-6
5.7. Installing the accessories .....	5-6
5.8. Electrical connection .....	5-7
<b>6. Functional description</b> .....	<b>6-1</b>
6.1. General .....	6-1
<b>7. Technical data</b> .....	<b>7-1</b>
<b>8. Spare parts list</b> .....	<b>8-1</b>
<b>9. Accessories</b> .....	<b>9-1</b>
<input type="checkbox"/> conveyor hopper SSE 15 / SSE 30	
<input type="checkbox"/> conveyor hopper _____	
<input type="checkbox"/> side vane vacuum pump GSV	
<input type="checkbox"/> rotary value pump GDS	
<input type="checkbox"/> rotary lobe vacuum pump GDK	
<input type="checkbox"/> _____	
<b>10. Electrical manual</b> .....	<b>10-1</b>
<input type="checkbox"/> Connection diagram no.: _____	
<input type="checkbox"/> Currently not available; will be delivered at a later date!	

## 1. Safety instructions

### 1.1. General



These safety instructions apply to all persons within the range of action of the equipment.

Please inform all persons within the range of action of the equipment of the direct and indirect hazards connected with the equipment.

These operating instructions are to be used by all persons assigned activities connected with the equipment.

Knowledge of the English language is prerequisite.

Ensure in each case that the operating personnel are familiar with the operating instructions and the function of the equipment.

## **1.2. For your safety**

### **General**

The operating personnel of this equipment must be at least 16 years old.

Please read these operating instructions carefully before taking into operation for the first time. Contact us should questions arise. This avoids injury and damage to equipment!

These operating instructions must be kept available at all times at the place of operation of the equipment. Improper operation results in danger of accidents!

Please note that, for reasons of clarity, not all conceivable cases regarding operation or maintenance of the equipment can be covered in these operating instructions.

Please observe all safety instructions and warnings on the equipment. This avoids injury and damage to equipment!

All work on the equipment is to be carried out by persons whose qualifications are specified in the pertaining chapters of the operating instructions. Improper operation results in danger of accidents!

The proper working clothes are to be worn during any work on the equipment. This avoids injury!

The local regulations and requirements pertaining to this equipment must be observed.

Disconnect electrical components from the mains supply before work is carried out on these components Caution: Danger to life through electrical shock!

Compile detailed operating instructions based on these Operating instructions for the sequence of procedures to be carried out on this equipment. Improper operation results in danger of accidents!

Please note that sound levels exceeding 85 db(A) may in the long term damage your health. Use the appropriate ear muffs. This avoids impairment of hearing!



## **Assembly**

Compare the connected loads with those of the mains supply. Danger of injury through electrical shock!

When using lifting gear, please observe the pertaining regulations. Caution: Danger of accidents!

Do not modify, add other equipment or change the design of the equipment without the approval of the manufacturer. Caution: Danger of accidents!

Attachments not supplied by Sterling must be manufactured in accordance with safety regulation EN 294. Danger of accidents!

The equipment may only be operated when all the associated components are properly connected up and in accordance with the relevant regulations. This avoids injury and damage to equipment!

Operate the device only if all its components are grounded. Danger: accident through electrical shock!

Solid particles and dust must be separated before entry to the vacuum generator. This avoids damage to equipment!

If PVC hoses are used for conveying, they must be grounded. This avoids injury and damage to equipment!

An acoustic cover should be installed when vacuum generators are located in work rooms. This avoids impairment of hearing!

## **Operation**

Appoint an equipment foreman to be responsible for the equipment.

Ensure that the operating personnel are provided detailed instruction in the operation of the equipment. Improper operation results in danger of accidents!

When the main switch is switched off for reasons pertaining to safety, it must be secured against unauthorized activation. Caution: Danger of accidents!

Repair work may be carried out by trained personnel only.  
Caution: Danger of accidents!

Never operate the equipment when partially dismantled!  
Danger! Limbs may be caught in machinery! Electric shock!

In case of malfunction, shut down the equipment immediately. Have malfunctions corrected immediately. Danger of accidents!

The equipment is intended only for conveying granulated plastics and regrinds. Any other or additional use is contrary to specifications.

This equipment is not suitable for food processing.

The safety instructions of the connected machines must be followed.

Explosive gases and mixtures of gas and air must not be conveyed. Danger of explosion! Avoids injury or damage to equipment!

## **Maintenance**

Before starting maintenance work, appoint a supervisor.

Inform the responsible personnel before maintenance work on the system is started. Caution: Danger of accidents!

Disconnect the equipment from mains supply before starting maintenance procedures to ensure that it cannot be switched on unintentionally.  
Caution: Danger of accidents!

All pipes, hoses and screwed connections should be checked regularly for leaks and damage. Any faults which arise should be corrected immediately.  
Danger of accidents!

Depressurise all compressed air piping before starting maintenance work.  
Danger of accidents!

---

## For the operating safety of the equipment

### 1.3. For the operating safety of the equipment

Never change settings if the consequences are not precisely known.

Use only original Sterling spare parts.

Please observe the maintenance schedule.

Keep record of all maintenance and repair work.

Please note that electronic components may be damaged by static discharge.

Check all electrical connections for proper fit before the equipment is taken into operation for the first time and at regular intervals.

Please ensure that the permitted operation temperature lies between 0 °C and +45 °C (32°F and 113°F).

Please ensure that the permitted storage temperature lies between -25 °C and +55 °C (-13°F and 131°F).

Note down all setting data.

After connection to the electricity supply has been made, check the rotational direction of the vacuum generators (note the direction indicated by the arrow).

Please ensure that all plugs are correctly plugged in.

The operating instructions of the connected machines must be followed.

All components must be sufficiently grounded.

Please note that a compressed air supply is required for the operation of the unit.

Never set a higher operating pressure than 6 bar (87.02 PSI) for the unit (system overpressure).

Align the suction tubes correctly.

Please note that the maximum permitted ambient and air temperature on entry to the vacuum generator is 40 °C (104°F).

## **2. Concerning these Operating Instructions**

### **2.1. General Information**



These operating instructions are addressed to all users of the device.

These operating instructions must be used by every person charged with work on the unit.

### 2.2. Warning Messages and Symbols

The following warning messages and symbols are used in these operating instructions:



This symbol indicates danger to life! Fatal or serious injury is possible if the corresponding instructions, regulations or warnings are not observed.



This symbol indicates that serious injury is possible if the corresponding instructions, regulations or warnings are not observed.



This symbol indicates that extensive damage to equipment is possible if the corresponding instructions, regulations or warnings are not observed.



This symbol indicates information important for becoming familiar with the equipment, i.e. technical correlations.



This symbol indicates that a technical term is explained at this point.

### 2.3. Explanations and Definitions

In this operating manual, certain terms are used repeatedly for better clarity. Therefore please keep in mind that these terms stand for the explanations given here.

- **Unit**  
“Unit” may designate either a single device, a machine or a plant.
  
- **User**  
The user is the person who uses the unit on his or her own responsibility or on the responsibility of someone else.
  
- **Operator**  
The operator of a unit (production manager, foreman etc.) is the person responsible for the sum of the processes. The operator instructs the users to do something.
  
- **Operating manual**  
The operating manual describes the correlations between several units, processes or manufacturing procedures. The operating manual must be prepared by the operator of the units.
  
- **Co-ordinator**  
If several users work on one unit, the “co-ordinator” co-ordinates the processes. The co-ordinator must be designated by the operator.
  
- **Trained personnel**  
Trained personnel are people who are qualified by their training to carry out the respective work in a professional manner.

## **2.4. Notes on Usage**

- Experienced operators can begin directly with the chapter on “Start-up” if the unit has been properly installed.
- If the unit has not been installed yet, observe the instructions in the chapter on “Assembly Instructions”.

### 3. Start-up

#### 3.1. General



This chapter is directed at the operator of the equipment.

This chapter assumes general skills in dealing with conveying units and SPS control units.

This chapter assumes that the functional description has been read and understood.

It should be ensured in each and every case that the operators have the relevant skills.

Explosive gases and mixtures of gas and air must not be conveyed by the vacuum generator. Solid particles and dust must be separated before entry to the vacuum generator.



Check the compressed air supply if pneumatic valves are present (5-6 bar (72.52-87.02 PSI) system overpressure).

Check whether the plastic stoppers have been removed from the suction pipe of the vacuum generator.

Check that the on/off switch is in position "OFF".



### 3.2. Control system

The facility's control system is factory-programmed. Nevertheless, you have to set specific values (basic parameters) which are dependent on the processed material, for instance.

The set values are saved and remain saved even after switching off or after a power fail. All entries are saved and can also be viewed at a later point in time. All messages are displayed in plain text.

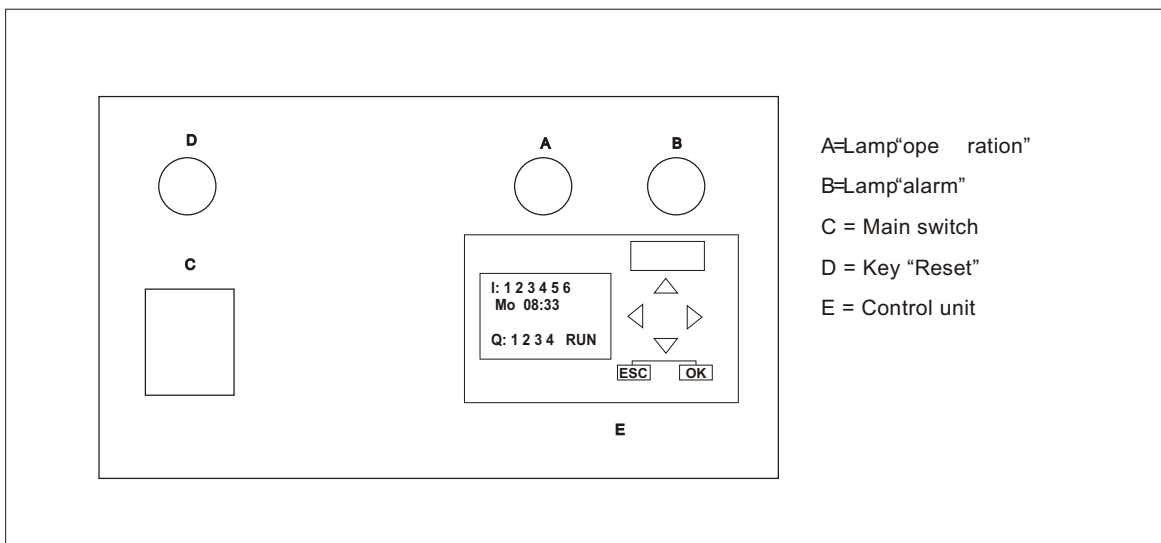

Switchbox

#### 3.2.1. Operation

The control system is operated via the keys "ESC", "OK" and the arrow keys (A).

Messages are displayed on a four-line display.

In the first display line the parameter designation is displayed.

In the second display line the set value of the parameter is displayed.

In the last display line the actual value of the parameter is displayed.

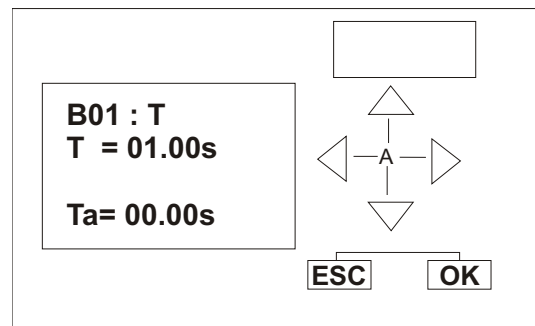

### 3.2.2. Key assignment

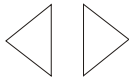

Arrow keys  
to select a value

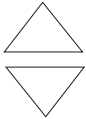

to scroll the menu pages  
to change a value

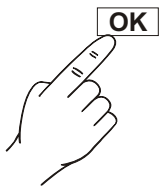

Pushing the key "OK"  
to select a menu, to change values (the cursor bar jumps to the first digit of the value);  
to confirm value entries (with value acceptance).



Pushing the key "ESC"  
to leave value entries (without value acceptance);  
to leave the menu "basic parameters".

### 3.3. Switching on the control system

Connect the control system to mains supply by the device plug.



Check that the on/off switch is in position "OFF".

3.4. Setting the basic parameters

Select the menu "basic parameter".

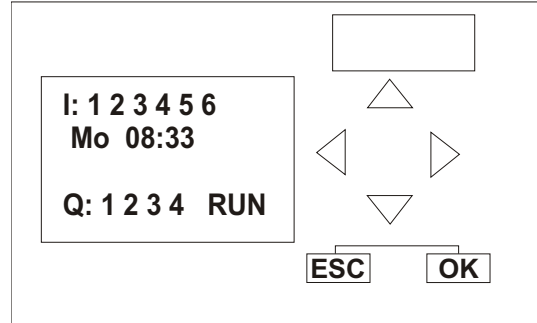

Select "Set Param".

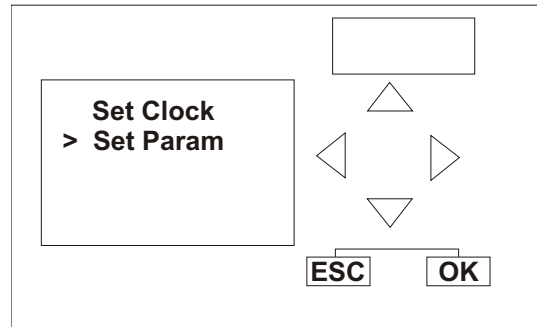
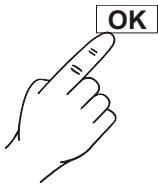

Signal times flap (B01)  
(standard setting: 1 second).

Changes only after consultation with  
the Sterling Service.

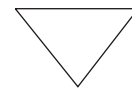
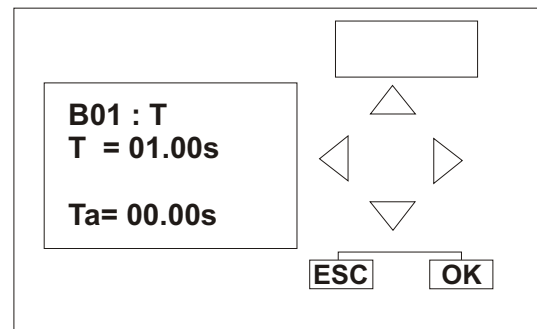
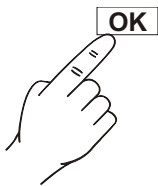

## Setting the basic parameters

### Conveying time (B05)

Enter the desired conveying time in seconds.

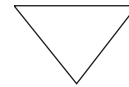
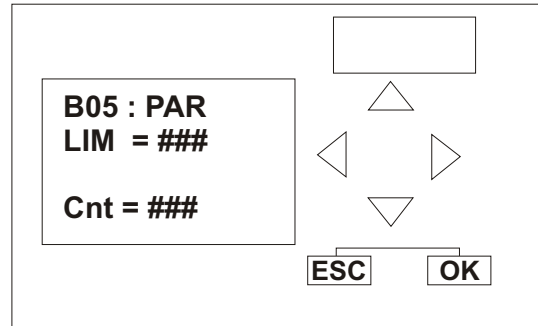
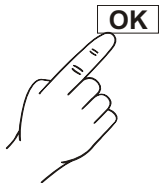

### Line clearing (B09)

Enter the desired line clear time in seconds.

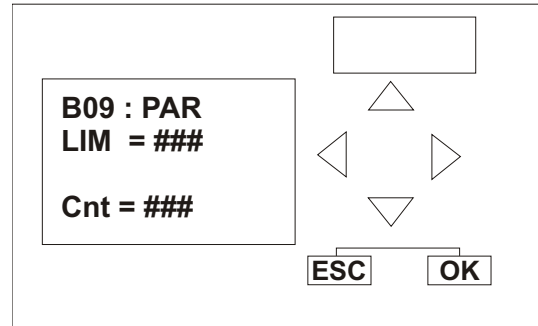
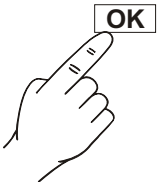

Enter "0" if no line clearing valve is mounted.

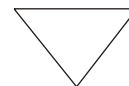

### Emptying time (B14)

Enter the desired emptying time in seconds.

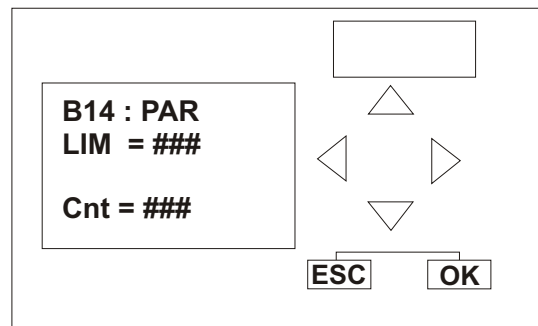
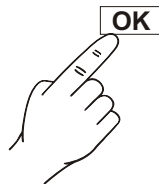

## Setting the basic parameters

### Blower run on time (B17)

Enter the blower run on time in seconds .

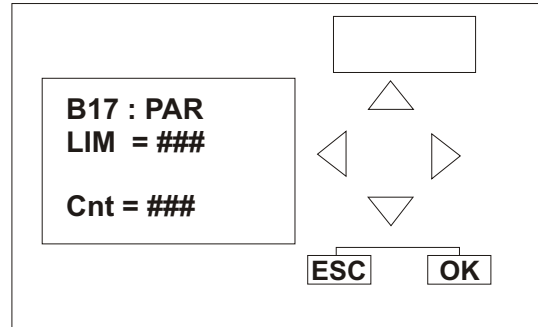

### Error tolerance (B22)

Enter the error tolerance.

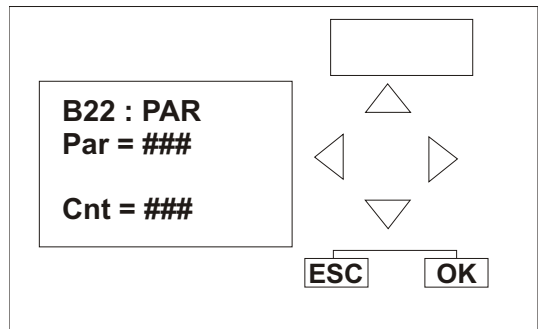
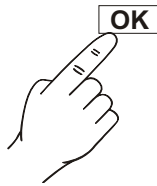

**Setting "0"**: function not active

**Setting "1-###"**: an alarm is given when the error tolerance reaches this value.

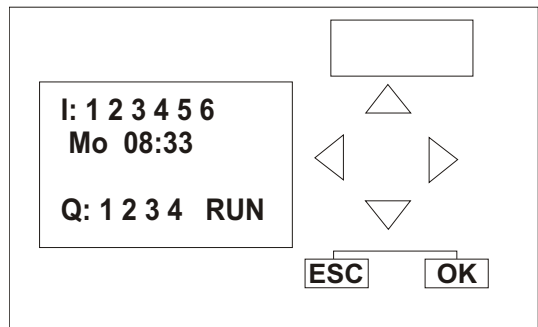
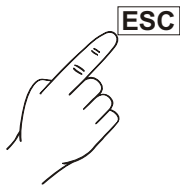

### **3.5. Starting the conveying procedure**

Set the on/off switch in position "ON".



If the hopper loader reports a lack of material, the conveying is started.

### **3.6. The first conveying operations**



Check the rotational direction of the vacuum generators.

Check the line system.

Adjusting the suction tube.

Material coming from the hopper loader during the first conveying may not be used.

### 3.7. Viewing Alarm Messages



An alarm is given by steady light of the “alarm” lamp.

Pressing the “Reset” key erases the steady light of the “alarm” lamp (the “alarm” lamp goes off). The failure is not repaired.



Failures must be repaired immediately.

#### Possible events:

##### - Fault hopper

**In the operating mode “probe conveying”**, the level of material has not reached the probe within the set conveying time.

Possible causes: lack of material, false conveying time setting or defective probe.

**In the operating mode “time-controlled conveyance”**, no signal change of the flap switch has occurred within the set emptying time.

Possible causes: lack of material, false emptying time setting or defective flap.

### **3.8. Switching off the unit**

Set the on/off switch in position "OFF".



If the unit is switched off during a conveying procedure this operation will be finished.

Disconnect the unit from mains supply by the device plug.



## 4. Maintenance

Version: 64.10-0198GB05WA 02/01

### 4.1. General



This chapter is intended for persons with skills in electrical and mechanical areas due to their training, experience and received instructions.

Personnel using the instructions in this chapter must be instructed of the regulations for the prevention of accidents, the operating conditions and safety regulations and their implementation.

Ensure in each case that the personnel are informed.

For maintenance work taking place at heights of over approx. 1829 mm. (6 ft.), use only ladders or similar equipment and working platforms intended for this purpose. At greater heights, the proper equipment for protection against falling must be worn.

Use only suitable lifting gear which is in proper working order and load suspension devices with sufficient carrying capacity. Do not stand or work under suspended loads!

Ensure that the electric motors/switch cabinets are sufficiently protected against moisture.

Use only suitable workshop equipment.

Before starting maintenance work, appoint a supervisor.

Inform the responsible personnel before maintenance work on the system is started.

Never operate the equipment when partially dismantled.

All maintenance and repair work not described in this chapter may only be carried out by Sterling service personnel or authorized personnel (appointed by Sterling).



Disconnect the equipment from mains supply before starting maintenance procedures to ensure that it cannot be switched on unintentionally.

Depressurize all compressed air piping of the equipment before starting maintenance work.



Please observe the maintenance intervals.

Before starting maintenance work, clean the equipment of oil, fuel or lubricants.

Ensure that materials and incidentals required for operation as well as spare parts are disposed of properly and in an environmentally sound manner.

Use only original Sterling spare parts.

Keep record of all maintenance and repair procedures.

## **4.2. Maintenance schedule**

Initial operation:	Check the rotational direction of the vacuum generators Check the line system Adjust the suction tube
Daily:	Check warning signs on equipment for legibility and completeness  Check the oil level in the oiler Empty the water separator Check operating pressure of the plant's supply network (5-6 bar (72.52-87.02 PSI) system over pressure)  Check the oil level in rotary valve pumps Follow the manufacturer's operating instructions
Weekly/monthly:	Clean the filter cartridge (according to the accumulation of dust)  Check that the main switch on the equipment is functioning
Every six months:	Replace the filter cartridge (according to the accumulation of dust)  Check the settings on the level probes (if present)  Check that all electrical and mechanical connections fit securely  Change oil and oil filters on the rotary valve pumps Follow the manufacturer's operating instructions  Lubricate the bearings with high melting-point grease on the rotary lobe vacuum pumps Follow the manufacturer's operating instructions

## Maintenance schedule

---

After the first 100  
hours of operation:

Change the oil on the rotary valve pumps  
Follow the manufacturer's operating instructions

After 500 hours  
of operation:

Check oil level and condition of the oil in the gear  
box of the rotary lobe vacuum pumps  
Follow the manufacturer's operating instructions

After 20,000 hours  
of operation:

Remove old grease from anti-friction bearing  
of side vane vacuum pump and apply fresh grease  
Follow the manufacturer's operating instructions



The given maintenance intervals are average values.

Check whether in your individual case the maintenance intervals must be shortened.

## Checking the direction of rotation of the vacuum generator

### 4.3. Checking the direction of rotation of the vacuum generator

Start a conveying procedure.

Wait until the vacuum generator begins to operate.

Observe the rotational direction arrow on the vacuum generator housing.

Stop the conveying procedure.

Wait until the blower has come to a standstill.

Switch off the unit.

If the vacuum generator rotates in the wrong direction, correct the direction by changing the poles of two phases.



Electrical connections should only be carried out by trained staff.

Observe the regulations of your local Electricity Board.



The wrong direction of rotation may lead to major defects or may interfere with the function of the vacuum generator.

A proper conveyance is not possible.

#### **4.4. Testing the conduit system**

Detach the flexible line from the connected material take-up assembly.

Close the open end of the line with your hand.

Start a conveying procedure.

Wait until the vacuum generator begins to operate; after this, the hand should become sensibly attached by suction within a few seconds.

If no vacuum can be felt, the line system has a leak.

Stop the conveying procedure.

Wait until the blower has come to a standstill.

Switch off the unit.

Check the line system and seal the leakage.

Re-connect the conveying line.

**4.5. Adjusting the suction tube**

To guarantee a trouble-free operating run, the suction tube must be exactly adjusted.

1. The suction tube should be placed in the basic setting

In the basic setting, the inner pipe of the suction tube sticks out of the outer pipe

approx. 120-160 mm . . . . .	with Ø 40 mm
. . . . . (4.72-6.30 in)	with (1.67 in)
approx. 150-180 mm . . . . .	with Ø 50 mm
. . . . . (5.91-7.19 in)	with (1.97 in)
approx. 180-200 mm . . . . .	with Ø 65 mm
. . . . . (7.19-7.97 in)	with (2.66 in)

2. Start the conveying process.
3. Observe the flexible line on the suction tube.

The flexible line must not be describing any pulsating movements.

4. Observe the flexible line on the separator.

The supply hose may only move when conveying is taking place.

**If conditions (points 3 + 4) are not fulfilled:**

Pull the inner pipe further out of the outer pipe until the jerky conveying stops.

**If the conditions (points 3 + 4) are fulfilled:**

Push the inner pipe slowly into the outer pipe, until a pulsating of the flexible line or a jerky conveying starts.

Pull the inner pipe back another bit, until the lines have stopped pulsing.

Select the adjustment between the two pipes in such a way that that there is always sufficient airflow in the material line.

If the conveying is proceeding satisfactorily, tighten the wing screw on the suction tube.

## 4.6. Cleaning/replacing the filter cartridge



Stop the conveying procedure.  
Switch off the conveying system at the main switch.  
Interrupt the mains supply.  
Set all compressed-air lines at zero pressure.



The conveying capacity is diminished by a clogged filter cartridge.

Loosen the screw connection on the filter housing (A).

Remove the housing lid (A).

Loosen the screw connection on the filter cartridge.

Remove the filter cartridge.

Replace the filter cartridge.

### **Resp.**

Use compressed air to blow through the filter cartridge from the inside to the outside.

Clean the filter housing. Use lint-free cleaning rags.

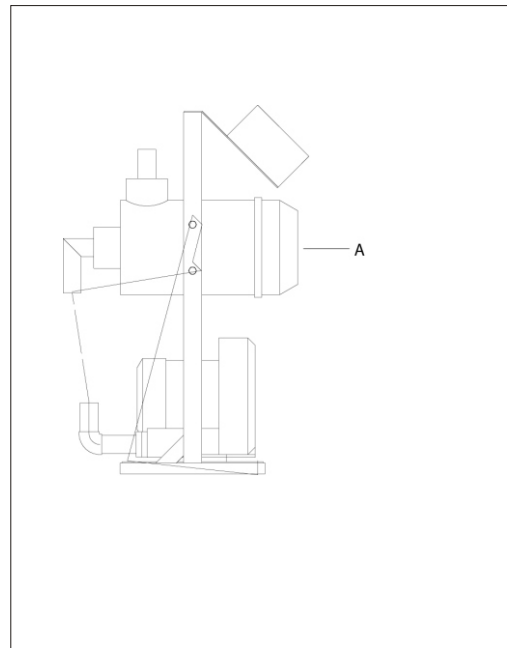



---

## Servicing the accessories

Re-install the new/cleaned filter cartridge.

Mount the housing lid.



Purchase order number

filter cartridge: ID 85612

### 4.7. Servicing the accessories



The operating instructions must be followed.

---

## 5. Assembly instructions



These installation instructions are intended for persons with skills in electrical and mechanical areas due to their training, experience and received instructions.

Personnel using these installation instructions must be instructed in the regulations for the prevention of accidents, the operating conditions and safety regulations and their implementation.

Ensure in each case that the personnel are informed.

The installation instructions provided in the corresponding operating instructions apply for all connected equipment.

Observe safety regulations with regard to lifting gear handling

All installation work must be carried out with the equipment disconnected from electrical power and compressed air supply.



For installation work taking place at heights of over approx. 1829 mm. (6 ft.), use only ladders or similar equipment and working platforms intended for this purpose. At greater heights, the proper equipment for protection against falling must be worn.

Use only suitable lifting gear which is in proper working order and load suspension devices with sufficient carrying capacity. Do not stand or work under suspended loads!

Use suitable workshop equipment.



Install the equipment such that all parts are easily accessible; this facilitates maintenance and repair work.

### 5.1. Transport

For transport, only the appropriate lifting gear should be used (eg fork lift or workshop crane).



Please ensure the adequate carrying capacity of the lifting gear.  
Please observe all safety regulations for the operation of lifting gear.

### 5.2. Installation

The location of the control unit should be chosen so that a clear view of the separators is guaranteed from the control unit. Thus any malfunctions which arise can be corrected more easily.



The main switch on the control unit must be freely accessible at all times.

### 5.3. Material feed

Suction pipes type MV may be tilted by approx. 45 degrees in either direction to the vertical. Additional fastening is not required.

When conveying from the bottom of storage containers (silos), a suction box with 1-3 suction pipes is required.

The connection of the suction pipes must be carried out with a piece of flexible line to provide sufficient movement.

## Suction pipe

Please observe that the length of the hose should not exceed 3 m (9.84 ft.) Push the free pipe end into the flexible line to a depth of approx. 4-5 cm (1.67-1.97 in.) Connect both parts by means of a hose clamp.

### 5.4. Suction pipe

The suction pipe consists of an inner (A) and an outer pipe (B) which can be offset against each other.

Push the free pipe end into the flexible line to a depth of approx. 4-5 cm (1.67-1.97 in.)

Connect both parts by means of a hose clamp.

Please observe that the length of the hose should not exceed 3 m (9.84 ft.)

Please check that the outer pipe is not covered as it provides for unhindered access of ambient air.



When conveying from silos, material hoppers and storage containers, a suction box with 1-3 suction pipes is required.

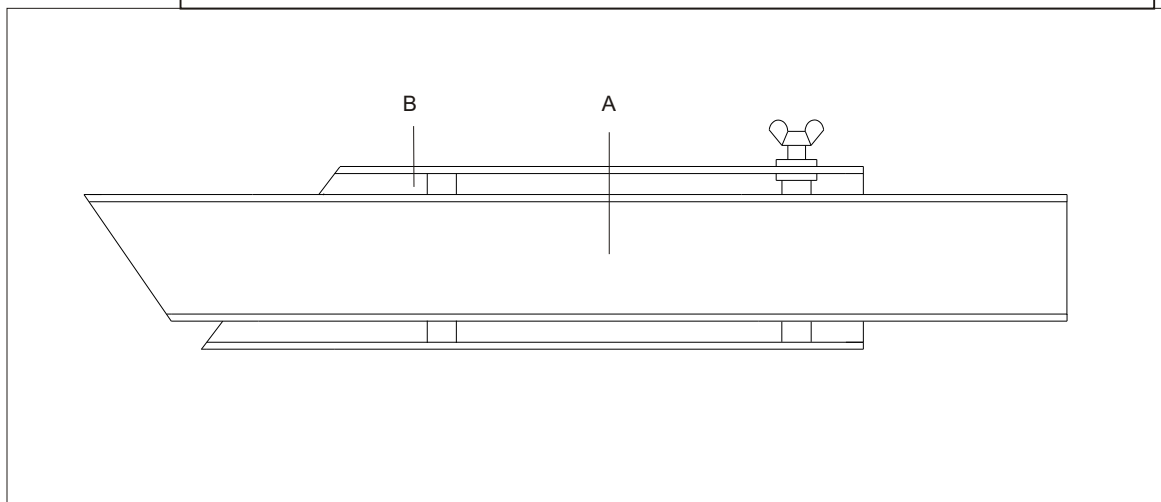

MV

### 5.5. Pipework

When all the positions and arrangement for material feed, hopper loader and blower are determined, start assembling the pipework.

Rigid pipes should always be laid next to each other and there should be the following minimum distances in between:

- 40 mm (1.67 in.) pipe diameter . . . . . 75 mm (2.95 in.) center distance
- 50 mm (1.97 in.) pipe diameter . . . . . 85 mm (3.35 in.) center distance
- 65 mm (2.66 in.) pipe diameter . . . . . 150 mm (5.91 in.) center distance

Laying the pipe can be done on wall brackets, energy supply bridges or in ducts in the floor. Combinations are also possible. Devices according to the local environment have to be provided to allow for screwing of the pipes if they are laid on. The distance between the individual supports should not be more than 3 to 4 m (9.84-13.12 ft) with smooth pipes. Elbows have to be fastened twice. Also it is absolutely necessary to provide support for conveying branches if there are any.

Line laying is normally started with the suction line, parting from the blower. Initially, a piece of flexible line of approx. 1 m (3.38 ft.) should be provided to avoid the transfer of oscillations. Flexible lines have to be pushed onto rigid lines and connection pieces at a depth of at least 5 cm (1.97 in.) Use hose clamps for fastening. Pipes are connected by means of wide band clamps and rubber muffs. Please check that the pipes are free from gaps and that the clamp is tight. Elbows have to be installed (also in the suction line) on joints from the vertical to the horizontal and where the direction changes. Minor directional changes can be overcome by bending straight lines. A minimum bending radius of 500 mm (19.79 in.) should always be observed (energy loss!).

When assembling conveying branches the minimum distance between machine throat center and discharge of conveying branch must be at least 1.5 m (4.92 ft.) to avoid too small a bending radius. When arranging the flexible connection line movements of the processing machine during operation or during mould change have to be taken into consideration! Assembly of the conveying line is started at material takeup . For line laying the same instructions given for suction line apply.

If PVC hoses are used for conveying, they must be grounded: draw out the copper lead on both ends of the hose and jam it between hose and tube. For fastening, use threaded clamps.

## 5.6. Vacuum generator



Explosive gases and mixtures of gas and air must not be conveyed.

Solid particles and dust must be separated before entry to the vacuum generator.

For all work on the equipment, hearing protection should be worn.

Avoids impairment of hearing!

The manufacturer's operating instructions should be followed.



An acoustic cover should be installed when vacuum generators are located in work rooms.



When installing an acoustic cover, care should be taken that the ventilation of the electric motors is not impeded.



Examples for the expected noise level:

side vane vacuum pump GSV

2.2 kW: approx. 72 dB (A)

4.0 kW: approx. 75 dB (A)

rotary vane pump GDS

7.5 kW: approx. 75 dB (A)

11.0 kW: approx. 77 dB (A)

rotary lobe vacuum pump GDK

4.0 kW: approx. 78 dB(A)

---

## Installing the accessories

The vacuum generator should be installed near the equipment, to avoid loss of performance through leakage and friction.

Only flexible connections should be used to join up the pipes.

The control unit should be installed in clear view of the vacuum generator.

To keep noise to a minimum, we recommend installation in an enclosed space.

### 5.6.1. Rotary lobe vacuum pump GDK



The fan is equipped with a separate electric motor which must be connected to 24 V.

### 5.7. Installing the accessories



The operating instructions must be followed.

### 5.8. Electrical connection



The regulations of the local Electricity Board must be observed.

Before connection to the electricity supply, it should be ensured that the supply voltage and the power frequency are in accordance with the data on the name plate of the machine.

The electrical connection may only be carried out by Sterling service staff or trained personnel authorised by Sterling.

It is not permitted for other persons to undertake the electrical connection.



Check that the on/off switch is in position "OFF".

The operating voltage is 480/3/60  
Special voltages on request.

Depending on the model, the connected load is up to 11.0 kW.



## 6. Functional description

### 6.1. General



This functional description is intended for all operating personnel of the equipment.

Prerequisite for this functional description is general knowledge of conveying units and SPS control units.

Ensure in each case that the operating personnel are sufficiently informed.

The unit works on the pneumatic conveying principle. According to this, a vacuum generator (A) creates a vacuum, which extends through the pipe ducts and hose assemblies (B), through the separators (C) until it reaches the material take-up assembly (D).

The material which has been conveyed is then separated from the air inside the separator.

Depending on conveyor control system (E) and hopper loaders time conveying mode or probe conveying mode with conveying time used as monitoring time is possible.

A filter cartridge (F) in front of the vacuum generator purifies the aspirated air.



Conveying is not possible without movement of air in the material line.

If the hopper loader reports a lack of material, the conveying is started.

Following the conveying process, if line cleaning times are set, line cleaning takes place. The line cleaning valves interrupt the flow of material and allow air to flow into the connecting pipe. In this way the connecting pipe is cleared of material.

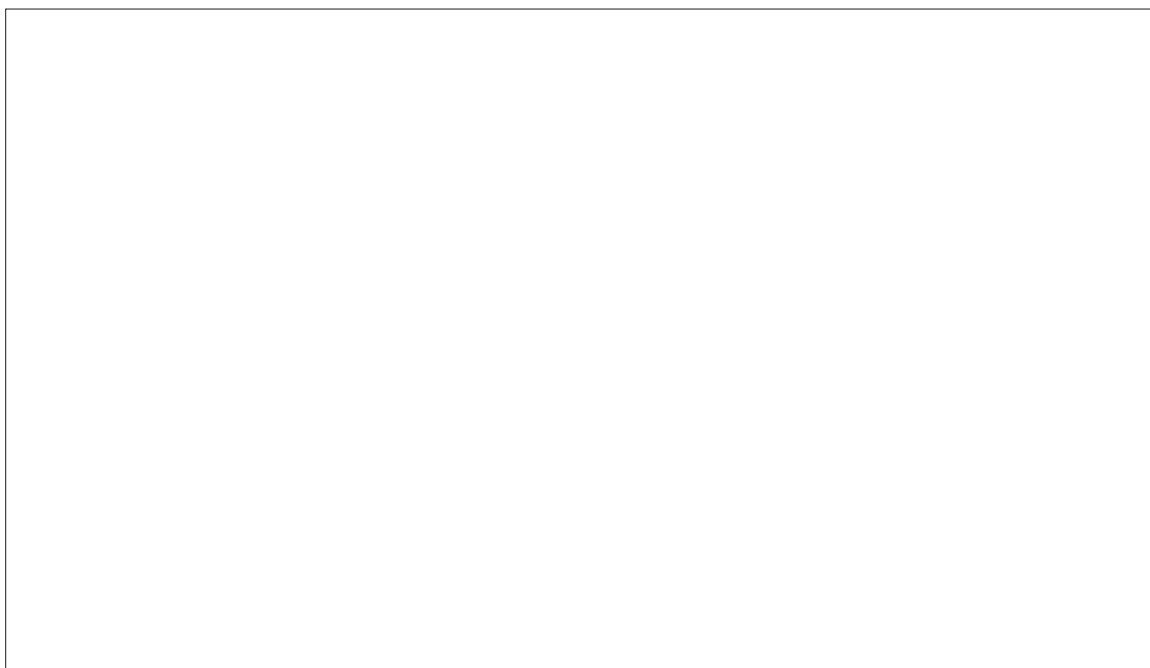

## 7. Technical data

Version: 64.10-0198GB05TD 02/01

Method of filling: . . . . . time conveying mode or probe conveying mode  
. . . . . with conveying time used as monitoring time

Vacuum generator (depending on the model)

Side vane vacuum pump GSV: . . . . . 1.5-4.4 kW

Noise level: . . . . . approx. 75-78 dB(A)

Rotary valve pump GDS: . . . . . 4.0-11.0 kW

Noise level: . . . . . approx. 73-75 dB(A)

Rotary lobe vacuum pump GDK: . . . . . 4.0 kW

Noise level: . . . . . approx. 78 dB(A)

Operating voltage (standard): . . . . . 400 V/3 AC/50 Hz  
(other voltages possible)

Permissible storage temperature: . . . . . -25 to +55 °C

. . . . . (-13° to +131° F)

Permissible operating temperature: . . . . . 0 to +45 °C

. . . . . (32° to +113°F)

Dimension sheet SGFE

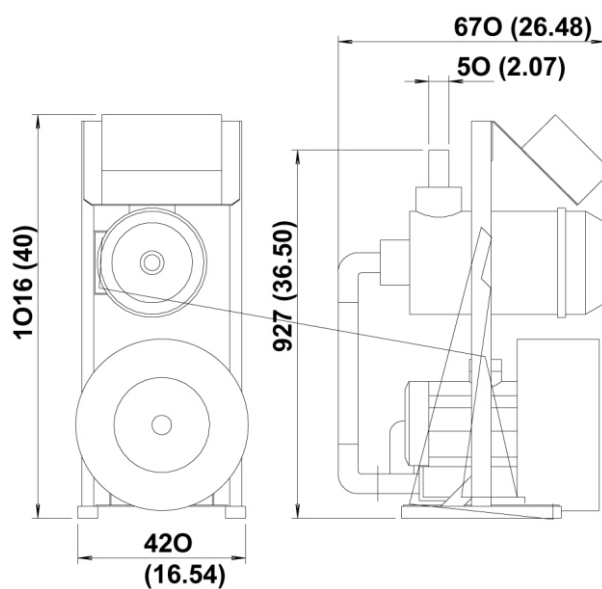

All dimensions are in mm. (in.) Subject to alteration.

### Dimension sheet GDK 4 kW

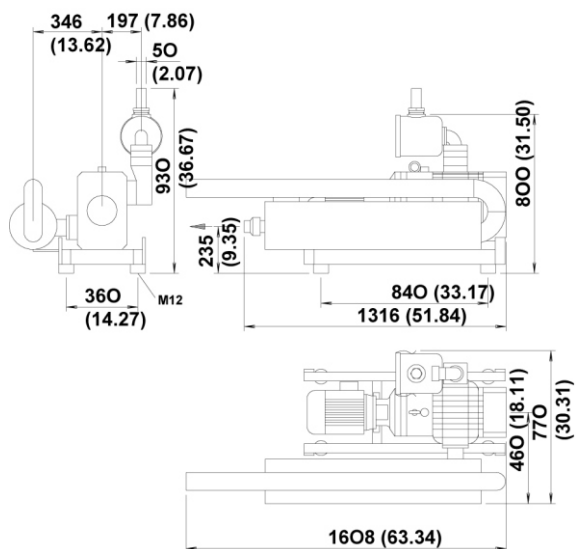

All dimensions are in mm. (in.) Subject to alteration.

### Dimension sheet GSV

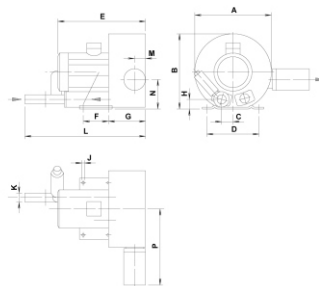

Typ	A	B	C	D	E	F	G	H	J	K	L	M	N	P
GSV40/2.2	382 (15.0)	384 (15.1)	63 (2.5)	290 (11.4)	347 (13.7)	140 (5.5)	109 (4.3)	54 (2.1)	15 (0.6)	40 (1.6)	573 (22.6)			
GSV90/2.2	382 (15.0)	384 (15.1)	63 (2.5)	290 (11.4)	347 (13.7)	140 (5.5)	109 (4.3)	54 (2.1)	15 (0.6)	50 (2.0)	573 (22.6)			
GSV40/4.0	425 (16.7)	410 (16.1)	63 (2.5)	290 (11.4)	488 (19.1)	140 (5.5)	205 (8.1)	54 (2.1)	15 (0.6)	40 (1.6)	669 (26.3)	60 (2.4)	164 (6.5)	423 (16.7)
GSV50/4.0	425 (16.7)	410 (16.1)	63 (2.5)	290 (11.4)	488 (19.1)	140 (5.5)	205 (8.1)	54 (2.1)	15 (0.6)	50 (2.0)	669 (26.3)	60 (2.4)	164 (6.5)	423 (16.7)

All dimensions are in mm. (in.) Subject to alteration.

### Dimension sheet GDS

Dimension sheet GDS

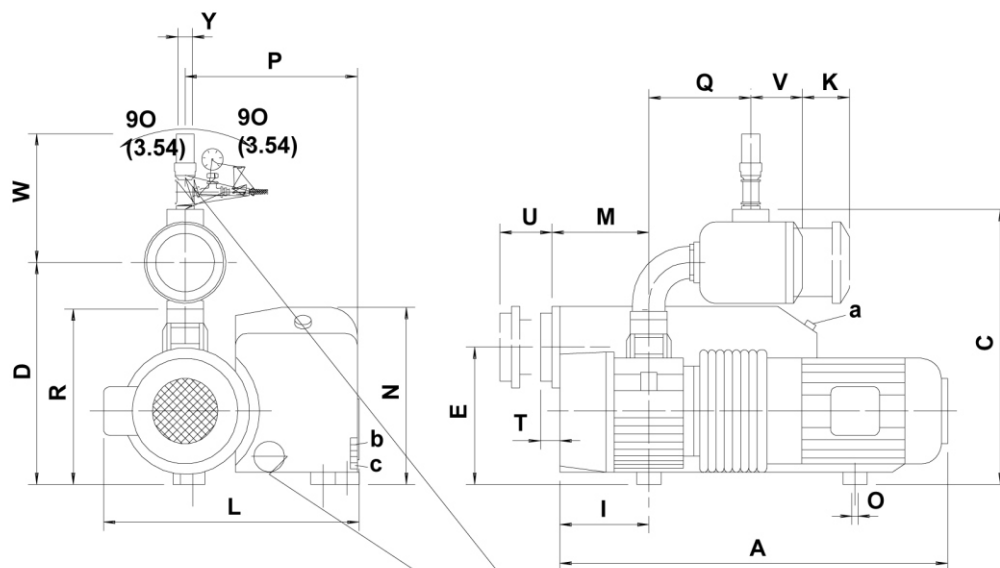

- a: Oeleinfuellung  
Oil-fillerplug  
Remplissage pour l'huile
- b: Oelstandskontrolle  
Oil level control  
Voyant niveau d'huile
- c: Oelablass  
Oil drain plug  
Vidange d'huile

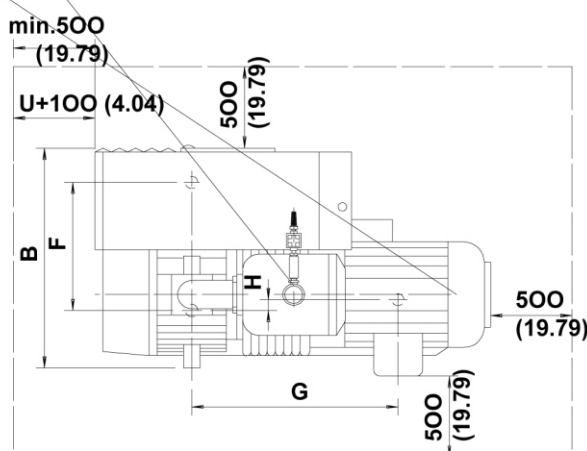

15	60	450 (992.1)	1308 (51.50)	870 (34.35)	1010 (39.86)	830 (32.78)	492 (19.47)	451 (17.86)	657 (25.97)	20.5 (0.81)	283 (11.14)	200 (7.97)
11	50	450 (992.1)	1268 (50.02)	870 (34.35)	1010 (39.86)	830 (32.78)	492 (19.47)	451 (17.86)	631 (24.94)	20.5 (0.81)	283 (11.14)	200 (7.97)
7.5	50/60	210 (462.0)	947 (37.38)	540 (21.36)	629 (24.86)	506 (20.02)	307 (12.19)	315 (12.40)	506 (19.92)	27 (1.16)	212 (8.35)	240 (9.45)
5.5	50/60	140 (308.6)	829 (32.64)	540 (21.36)	629 (24.86)	506 (20.02)	307 (12.19)	315 (12.40)	407 (16.02)	27 (1.16)	212 (8.35)	240 (9.45)
3	50/60	80 (176.4)	693 (27.38)	410 (16.14)	490 (19.39)	392 (15.43)	232 (9.13)	273 (10.75)	371 (14.61)	10 (0.49)	149 (5.97)	130 (5.12)
kW	Hz	(kg/lbs)	A	B	C	D	E	F	G	H	I	K

15	60	862 (33.94)	401 (15.89)	660 (26.08)	M12	608 (23.94)	438 (17.24)	670 (26.48)	118 (4.65)	618 (24.33)	115 (4.53)	420 (16.54)	65 (2.66)
11	50	842 (33.15)	401 (15.89)	660 (26.08)	M12	608 (23.94)	438 (17.24)	670 (26.48)	118 (4.65)	618 (24.33)	115 (4.53)	420 (16.54)	65 (2.66)
7.5	50/60	585 (23.03)	270 (10.63)	410 (16.14)	M10	372 (14.65)	250 (9.84)	400 (15.75)	58 (2.38)	433 (17.05)	119 (4.79)	315 (12.40)	50/65 (2.07/2.66)
5.5	50/60	585 (23.03)	270 (10.63)	410 (16.14)	M10	372 (14.65)	250 (9.84)	400 (15.75)	58 (2.38)	433 (17.05)	119 (4.79)	315 (12.40)	50 (2.07)
3	50/60	417 (16.42)	170 (6.79)	280 (11.02)	M8	278 (10.94)	215 (8.56)	285 (11.22)	21 (0.83)	271 (10.77)	62 (2.44)	230 (9.16)	50 (2.07)
kW	Hz	L	M	N	O	P	Q	R	T	U	V	W	Y

All dimensions are in mm. Subject to alteration.  
All dimensions are in mm. (in.) Subject to alteration.

## 8. Spare parts list



This spare parts list is intended to be used only by trained personnel.

Other persons are not permitted to modify or repair the equipment.

Pos.	ID-No.	Designation
1	93102	pressure limiter valve (1.5 and 2.2 kW)
	93100	pressure limiter valve (4.0 kW)
2	86308	side vane vacuum pump GSV 4.0 kW
	88235	side vane vacuum pump GSV 2.2 kW
	83564	side vane vacuum pump GSV 1.5 kW
<b>Optional</b>		
	84724	rotary lobe vacuum pump GDK 4.0 kW
	98148	manometer
	92156	rotary valve pump GDS 5,5 kW
	93650	rotary valve pump GDS 7,5 kW
	89430	rotary valve pump GDS 11,0 kW
	98148	manometer
3	85612	filter cartridge
	85486	lock nut
4	83411	control unit LOGO



## 9. Accessories

- conveyor hopper CSE 15 / CSE 30
- conveyor hopper -----
- side vane vacuum pump GSV
- rotary value pump GDS
- rotary lobe vacuum pump GDK
- 
- 
-

## 10. Electrical manual



This electrical manual is intended to be used only by Sterling service personnel and trained personnel authorized by Sterling.

Other persons are not permitted to modify or repair the equipment.

Connection diagram no.: \_\_\_\_\_

Currently not available; will be delivered at a later date!

## Free Manuals Download Website

<http://myh66.com>

<http://usermanuals.us>

<http://www.somanuals.com>

<http://www.4manuals.cc>

<http://www.manual-lib.com>

<http://www.404manual.com>

<http://www.luxmanual.com>

<http://aubethermostatmanual.com>

Golf course search by state

<http://golfingnear.com>

Email search by domain

<http://emailbydomain.com>

Auto manuals search

<http://auto.somanuals.com>

TV manuals search

<http://tv.somanuals.com>