



**Installation  
Operation  
Maintenance**

**RTAA-IOM-4A**

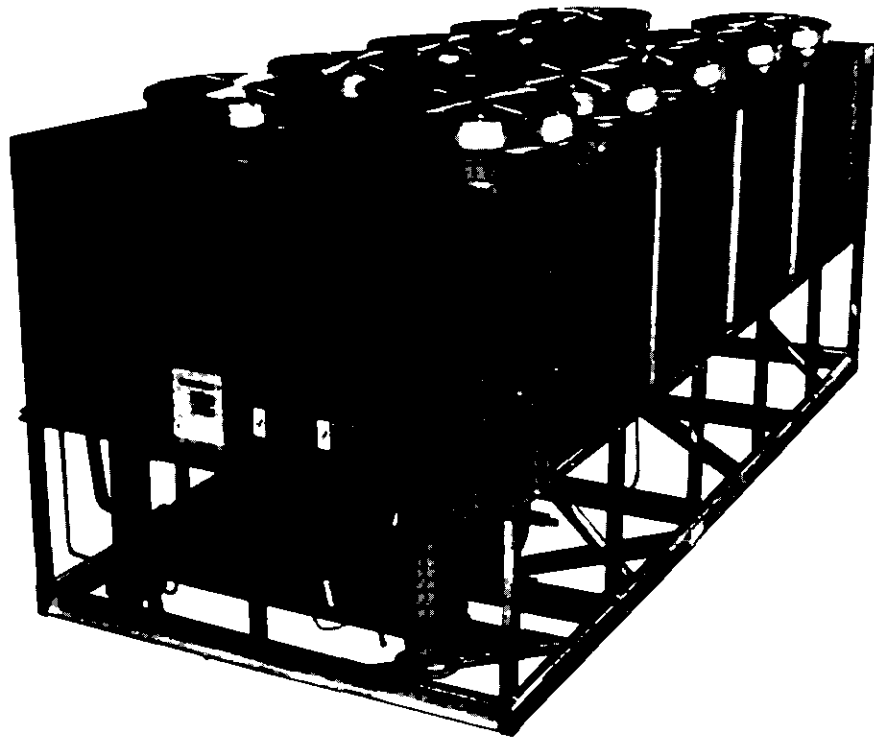
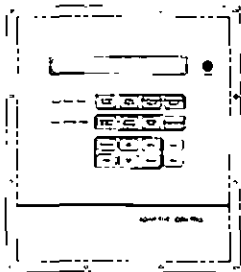
Library	Service Literature
Product Section	Refrigeration
Product	Rotary Liquid Chillers – Air-Cooled
Model	RTAA
Literature Type	Installation, Operation, Maintenance
Sequence	4
Date	March 1995
File No	SV-RF-RLC-RTAA-IOM-4-0395
Supersedes	RTAA-IOM-4

**Air-Cooled  
Series R®  
Rotary Liquid  
Chillers**

Design Sequence "AO" and Later  
Packaged Air-Cooled Chiller,  
RTAA 70-125

Remote Evaporator  
Air-Cooled Chiller,  
RTAA 70-125

Clear Language Display



**Models**

RTAA-70  
RTAA-80  
RTAA-90

RTAA-100  
RTAA-110  
RTAA-125

Part No. X39551156-01

---

## IMPORTANT NOTICE

Effective July 1, 1992, all service operations must use recovery systems to minimize losses of refrigerant to the atmosphere when servicing units with Class I and Class II refrigerants.

Class I (CFC) and Class II (HCFC) refrigerants include CFC-12, HCFC-22, CFC-500, CFC-502, CFC-11, CFC-113 and HCFC-123. Deliberate venting is prohibited by Section 608 of the Clean Air Act.

In the normal service of air conditioning systems, there are three major activities mandated by the EPA regulations: recovery, recycling and reclaiming.

**1) Recovery** — the act of removing refrigerant from the air conditioning unit so that losses of refrigerant to the atmosphere are minimized.

Whenever a refrigeration circuit is opened, the recovery of the refrigerant is required. If there is no reason to believe that the refrigerant is "bad", such as during service of gaskets, expansion valves or solenoid valves, the refrigerant is often returned to the unit without treatment. (Note: Always follow the equipment manufacturer's recommendations regarding replacement of unit filter driers during service.)

**If there is reason to suspect that the refrigerant is bad, such as with a compressor failure, the refrigerant should either be replaced or recycled.**

Recovery is also required when a piece of equipment is decommissioned. This prevents the loss of refrigerant upon disposal of the unit. The recovered refrigerant usually is sold to refrigerant reclaimers rather than reused in the customer's new equipment.

**2) Recycling** — the act of cleaning recovered refrigerant for use in the customer's equipment.

First, the refrigerant is boiled to separate the oil. Then it is run through a filter drier to separate moisture and acid.

Because of limited field testing capability, the quality and identity of any recycled refrigerant is suspect. For this reason, the EPA will most likely allow recycling of refrigerant only when it is returned to its original owner. Resale of the recycled refrigerant to third parties will not be allowed.

As a result, most servicers will only recycle refrigerant when the quantity of the refrigerant to be recycled and the expertise of the technician make it attractive to do so. Most suspect refrigerant will be sold to a reclaimer rather than be serviced in the field.

**3) Reclaiming** — the act of purifying refrigerant and testing it to ARI 700 "new" refrigerant standards. With reclamation, each batch of refrigerant undergoes extensive laboratory tests and the waste streams are disposed of according to environmental regulations.

Most reclamation will be done at centralized processing facilities because of the testing, waste handling and EPA certification requirements for reclamation. The Trane Company and others offer reclamation services for most refrigerants.

Reclamation is probably the most attractive alternative for users with salvaged and suspect refrigerant.

---

## Refrigerant Emission Control

Evidence from environmental scientists indicates that the ozone in our upper atmosphere is being reduced, due to the release of CFC fully halogenated compounds.

The Trane Company encourages every effort to eliminate, if possible, or vigorously reduce the emission of CFC, HCFC and HFC refrigerants into the atmosphere that result from installation, operation, routine maintenance, or major services on this equipment. Always act in a responsible manner to conserve refrigerants for continued use, even when acceptable alternatives are available.

Conservation and emission reduction can be accomplished by following recommended Trane operation, maintenance and service procedures, with specific attention to the following

1. Refrigerant used in any type of air conditioning or refrigerating equipment should be recovered for reuse, recovered and/or recycled for reuse, reprocessed (reclaimed) properly destroyed, whenever it is removed from equipment by an EPA certified Type II or Universal technician. Never release refrigerant into the atmosphere.
2. Always determine possible recycle or reclaim requirements of the recovered refrigerant before beginning recovery by any method. Questions about recovered refrigerants and acceptable refrigerant quality standards are addressed in ARI Standard 700.
3. Use approved containment vessels and safety standards. Comply with all applicable transportation standards when shipping refrigerant containers
4. To minimize emissions while recovering refrigerant, use recycling equipment. Always use methods which will pull the required vacuum while recovering and condensing refrigerant into containment
5. When leak checking with trace refrigerant and nitrogen, use HCFC-22 (R-22), rather than CFC-12 (R-12) or any other fully halogenated refrigerants. Be aware of any new leak test methods which eliminate refrigerant as a trace gas.
6. When cleaning system components or parts, avoid using CFC-11 (R-11) or CFC-113 (R-113). Refrigeration system clean up methods which use filters and dryers are preferred. Do not use solvents which have ozone depletion factors. Properly dispose of used materials.
7. Take extra care to properly maintain all service equipment that directly support refrigeration service work, such as gauges, hoses, vacuum pumps and recycling equipment.
8. Stay aware of unit enhancements, conversion refrigerants, compatible parts and manufacturer's recommendations which will reduce refrigerant emissions and increase equipment operating efficiencies. Follow manufacturer's specific guidelines for conversion of existing systems.
9. In order to assist in reducing power generation emissions, always attempt to improve equipment performance with improved maintenance and operations that will help conserve energy resources.

# Table of Contents

<b>1</b>	<b>General Information</b>	<b>34</b>	Refrigerant Sensors
1	Literature Change History	36	Leak Test and Evacuation
1	Unit Identification	36	Refrigerant and Additional Oil Charge
1	Unit Inspection	36	--Refrigerant Charge Determination
1	Inspection Checklist	36	--Example: Refrigerant Charge Computation
1	Loose Parts Inventory		--Oil Charge Determination
1	Unit Description		
5	Commonly Used Acronyms		
6	Warnings and Cautions	<b>37</b>	<b>Installation – Electrical</b>
6	Installation Responsibilities	37	General Recommendations
7	Nameplates	43	--Installer-Supplied Components
7	--Outdoor Unit Nameplate	43	Power Supply Wiring
7	--ASME Nameplate	43	--General
7	--Compressor Nameplate	44	--Control Power Supply
8	Model Number Coding System	45	--Heat Tape Power Supply
8	Storage	45	--Water Pump Power Supply
		45	Interlock Wiring
		45	--Alarm/Running/Maximum Capacity Outputs
<b>9</b>	<b>Installation - Mechanical Packaged Unit</b>	47	--Alarm/Running/Maximum Capacity Indicator Wiring
9	General	48	Low Voltage Wiring
9	Pre-Installation	48	--Emergency Stop (Normal Trip)
9	Location Requirements	48	--External Circuit Lockout – Circuit #1
9	--Noise Considerations	48	--External Circuit Lockout – Circuit #2
9	--Foundation	48	--Ice Making Option
12	--Clearances	49	--External Chilled Water Setpoint (CWS)
12	--Additional Location Requirements for Remote Evaporator Only	51	--External Current Limit Setpoint (CLS)
12	Rigging	52	--Optional Bidirectional Communication Link (BCL)
12	Lifting Procedures	52	----General
17	Unit Isolation	52	----Communication Link Connection Procedure
17	--Direct Mounting	53	Remote Clear Language Display Installation Procedure
17	--Isolator Mounting	53	--General
17	----Neoprene Isolators	53	--Remote CLD Mounting
17	----Spring Isolators	55	--Remote CLD Panel Wiring
17	Unit Leveling	55	--ICS Address Setting
17	Water Piping	55	--Multiple Unit Operation
20	--Evaporator Water Piping	56	Installation Check List
20	--Evaporator Refrigerant Relief Valve Piping	56	--Receiving
20	--Evaporator Piping	56	--Unit Location and Mounting
21	--Evaporator Piping Components	56	--Unit Piping
21	----Entering Chilled Water Piping	57	--Electrical Wiring
21	----Leaving Chilled Water Piping		
21	--Evaporator Drain		
21	--Chilled Water Flow Switch		
23	--Water Treatment		
23	--Water Pressure Gauges		
23	--Water Pressure Relief Valves		
23	--Freeze Protection		
<b>25</b>	<b>Installation – Mechanical Remote Evaporator Interconnecting Refrigerant Piping</b>		
25	General	<b>59</b>	<b>Operating Principles – Mechanical</b>
25	System Configuration and Interconnecting Refrigerant Piping	59	General
31	Line Sizing	59	Refrigeration (Cooling) Cycle
31	--Liquid Line Sizing Steps	59	--Cycle Description
32	--Example Liquid Line Sizing	60	--Compressor Description
32	--Suction Line Sizing Steps	60	----Compressor Motor
33	--Example Suction Line Sizing	60	----Compressor Rotors
33	--Suction Accumulator Sizing	61	----Compressor Loading Sequence
34	Piping Installation Procedures	61	Oil System Operation
		61	--Overview
		61	--Oil Separator
		63	--Compressor Bearing Oil Supply
		63	--Compressor Rotor Oil Supply
		63	--Female Unloader Valve
		63	--Oil Filter
		63	--Condenser Fan Staging

<b>65 Operating Principles - Adaptive Control™ Microprocessor Logic with Clear Language Display</b>	<b>109 Pre-Start Checkout</b>
65 General	109 General
67 Clear Language Display Keypad Overview	110 Unit Voltage Power Supply
67 --General	110 Unit Voltage Imbalance
68 --Select Report Group	111 Unit Voltage Phasing
68 --Select Settings Group	112 Water System Flow Rates
68 --Passwords	112 Water System Pressure Drop
68 --Select Report Group and Select Settings Group Flowcharts	112 Clear Language Display Set-up
69 --Auto/Stop Keys	<b>113 Start-up Procedures</b>
69 --Power Up	113 General
87 Diagnostics	115 System Superheat
100 Operational Features	115 System Subcooling
100 --Entering Evaporator Water Temperature	<b>117 Unit Shutdown Procedures</b>
100 --Current Limit Setpoint	117 Temporary Shutdown and Restart
100 --Low Ambient Lockout	117 Extended Shutdown Procedure
100 --Electronic Expansion Valve (EXV) Test	118 System Restart After Extended Shutdown
100 --Current Overload Protection	<b>119 Periodic Maintenance</b>
100 --Leaving Chilled Water Temperature Control	119 General
100 --Chilled Water Reset (CWR)	119 Weekly Maintenance
102 --Leaving Water Temperature Cutout	119 Monthly Maintenance
102 --Low Refrigerant Temperature Cutout	119 Annual Maintenance
104 --Low Ambient Temperature Start	<b>123 Maintenance</b>
104 ----Low Refrigerant Temperature Cutout and Low Pressure Cutout Retry	123 General
104 --Balanced Compressor Starts and Hours	123 Coil Cleaning
105 --Phase Imbalance Protection	123 Chemically Cleaning The Evaporator
105 --Reverse Rotation Protection	124 Water Treatment
105 --Oil Failure Protection	124 Oil Separator Level Check
105 DIP Switch Settings	125 Oil Filter Change
105 --Compressor Overload DIP Switches	<b>127 Refrigerant Charging and Recovery</b>
105 IPC Address	127 Low Side Repairs
107 --2-10 VDC/4-20 mA Input for External Chilled Water Setpoint (CWS) and Current Limit Setpoint (CLS)	127 High Side Repair
107 --Mechanical Control Settings	127 Adding Refrigerant
107 --Remote CLD Operation	<b>129 Unit Wiring</b>
107 --Communication Failure	129 General
	129 Unit Electrical Data

# List of Illustrations

2	Figure 1 Typical RTAA Packaged Unit 70–125 Tons (Front/Side Exterior View)	26	Figure 9b Remote Evaporator Installation No Elevation Difference, Suction and Liquid Lines 15 Feet or Less	55	Figure 20 Remote Display Panel Interconnecting Wiring
3	Figure 2 Typical RTAA Packaged Unit 70–125 Tons (Rear Exterior View)	27	Figure 9c Remote Evaporator Installation Condensing Unit Above Evaporator – 100 Feet or Less	59	Figure 21 Refrigeration System and Control Components
7	Figure 3 Nameplates	27	Figure 9d Remote Evaporator Installation Condensing Unit Below Evaporator – 15 Feet or Less	60	Figure 22 RTAA Refrigerant and Oil Diagram
8	Figure 4 Model Number Coding System	28	Figure 9e Refrigerant Circuit Identification	62	Figure 23 Oil Separator
10	Figure 5 Rigging and Lifting Weights – Packaged Unit	32	Figure 9f Liquid Line Sizing Example	64	Figure 24 Fan State at Circuit Startup
11	Figure 5a Rigging and Lifting Weights – Remote Evaporator	33	Figure 9g Suction Accumulator Sizing Example	66	Figure 25 RTAA Control Panel
13	Figure 6 Dimensions and Clearances for RTAA Packaged Units 70 – 125 Tons	35	Figure 9h Refrigerant Sensor Mounting and Wiring	67	Figure 26 Operator Interface Adaptive Control
14	Figure 6a Dimensions and Clearances for RTAA with Remote Evaporator 70 – 125 Tons	37	Figure 10 Warning Label	70	Figure 27 Chiller Report
15	Figure 6b Remote Evaporator Dimensions, RTAA 70 – 100 Tons	38	Figure 11 Typical Field Wiring for RTAA Unit	72	Figure 28 Refrigerant Report
16	Figure 6c Remote Evaporator Dimensions, RTAA 110 – 125 Tons	40	Figure 11a Typical Field Wiring for RTAA Unit with Remote Evaporator	73	Figure 29 Compressor Report
18	Figure 7 Isolator Placement for Typical RTAA Packaged Unit 70 – 125 Tons	43	Figure 12 Control Box – Right Side	74	Figure 30 Operator Settings
19	Figure 7a Isolator Placement for RTAA with Remote Evaporator	44	Figure 13 Control Box – Front	77	Figure 31 Service Settings
20	Figure 8 Suggested Piping for Typical RTAA Evaporator	46	Figure 14 Typical RTAA Chiller Interlock	85	Figure 32 Service Tests
22	Figure 9 RTAA Evaporator Water Pressure Drop	47	Figure 15 Alarm/Running/Maximum Capacity Contact Outputs	88	Figure 33 Diagnostics
26	Figure 9a Remote Evaporator Installation No Elevation Difference, Suction and Liquid Lines 20 Inches or Less	49	Figure 16 Resistor and Potentiometer Arrangement for External Chilled Water Setpoint	104	Figure 34 Low Refrigerant Temperature and Low Pressure Cutout Ignore Time
		51	Figure 17 Resistor and Potentiometer Arrangement for External Current Limit Setpoint	111	Figure 35 Associated Research Model 45 Phase Sequence Indicator
		54	Figure 18 Remote CLD Panel Mounting Holes and Electrical Access Knockouts	114	Figure 36 Unit Sequence of Operation
		55	Figure 19 Shielded, Twisted Pair Communication Link at the Remote CLD Panel	121	Figure 37 Operator's Log
				123	Figure 38 Chemical Cleaning Configuration
				124	Figure 39 System Oil Level Specifications
				125	Figure 40 Oil Filter Change
				126	Figure 41 Oil Pressure Drop
				129	Figure 42 Legend
				130	Figures 43 – 46 Schematic Wiring
				138	Figure 47 Connection Wiring, X-Line
				140	Figure 48 Panel to Unit Wiring, X-Line
				142	Figure 49 Connection Wiring, Wye-Delta
				144	Figure 50 Panel to Unit Wiring, Wye-Delta
				146	Figure 51 Component Locations

# List of Tables

---

- 4 Table 1  
General RTAA Mechanical Specifications
- 5 Table 2  
RTAA Refrigerant Circuit Designations and Capacities
- 29 Table 2a  
RTAA Circuit Capacities (nominal tons)
- 29 Table 2b  
Equivalent Lengths of Non-Ferrous Valves and Fittings (feet)
- 30 Table 2c  
Liquid Line Sizes
- 30 Table 2d  
Suction Line Sizes ("O.D.") for Upflow Lines
- 30 Table 2e  
Suction Line Sizes ("O.D.") for Horizontal and/or Downflow Lines
- 31 Table 2f  
Additional Suction Accumulator Line
- 36 Table 2g  
System Refrigerant Charge
- 36 Table 2h  
Field Installed Piping Charge
- 42 Table 3  
Electrical Data
- 47 Table 4  
Alarm/Running/Maximum Capacity Relay Output Configurations
- 47 Table 5  
Alarm/Running/Maximum Capacity Menu Settings
- 50 Table 6  
Input Values vs External Chilled Water Setpoint
- 51 Table 7  
Input Values vs External Current Limit Setpoint
- 93 Table 8  
Diagnostic Codes
- 100 Table 9  
Compressor(s) Current Limit Setpoints vs. Chiller Current Limit Setpoint (CLS)
- 103 Table 10  
Leaving Fluid Temperature Setpoints
- 106 Table 11  
Compressor Overload DIP Switch Settings

# General Information

## Literature Change History

RTAA-IOM-4 (October 1993)

Original manual. Covers installation, operation, and maintenance of "AO" design sequence RTAA-70 thru RTAA-125 units.

## Unit Identification

When the unit arrives, compare all nameplate data with ordering and shipping information.

## Unit Inspection

When the unit is delivered, verify that it is the correct unit and that it is properly equipped. Compare the information which appears on the unit nameplate with the ordering and submittal information. Refer to "Nameplates".

Inspect all exterior components for visible damage. Report any apparent damage or material shortage to the carrier and make a "unit damage" notation on the carrier's delivery receipt. Specify the extent and type of damage found and notify the appropriate Trane Sales Office.

Do not proceed with installation of a damaged unit without sales office approval.

**Note:** If the Remote Evaporator Option is ordered, the remote evaporator will be shipped in a separate crate.

## Inspection Checklist

To protect against loss due to damage incurred in transit, complete the following checklist upon receipt of the unit.

- [ ] Inspect the individual pieces of the shipment before accepting the unit. Check for obvious damage to the unit or packing material.
- [ ] Inspect the unit for concealed damage as soon as possible after delivery and before it is stored. Concealed damage must be reported within 15 days.

[ ] If concealed damage is discovered, stop unpacking the shipment. Do not remove damaged material from the receiving location. Take photos of the damage, if possible. The owner must provide reasonable evidence that the damage did not occur after delivery.

[ ] Notify the carrier's terminal of the damage immediately, by phone and by mail. Request an immediate, joint inspection of the damage with the carrier and the consignee.

[ ] Notify the Trane sales representative and arrange for repair. Do not repair the unit, however, until damage is inspected by the carrier's representative.

## Loose Parts Inventory

Check all the accessories and loose parts which are shipped with the unit against shipping list. Included in these items will be water vessel drain plugs, isolators, rigging and electrical diagrams, and service literature, which are placed inside the control panel and/or starter panel for shipment.

## Unit Description

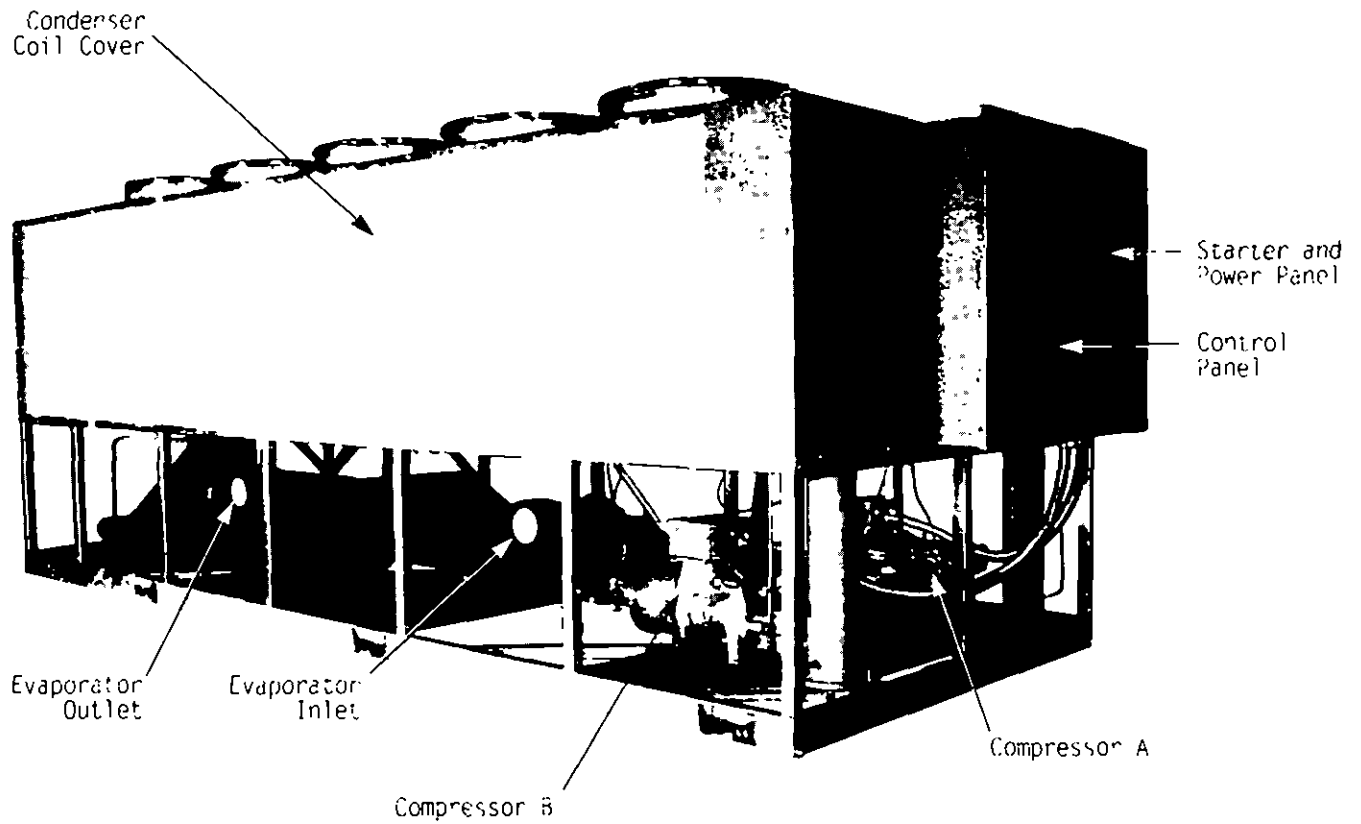
The 70 thru 125-ton Model RTAA units are helical-rotary type, air-cooled liquid chillers designed for installation outdoors. The unit has two compressors and the compressor circuits are completely assembled, hermetic packages. They are factory-piped, wired, leak-tested, dehydrated, and tested for proper operation before shipment. The units are factory charged with refrigerant and oil.

**Note:** Packaged units are factory charged with refrigerant and oil. Remote evaporator units are shipped with a holding charge of nitrogen and a partial charge of oil.

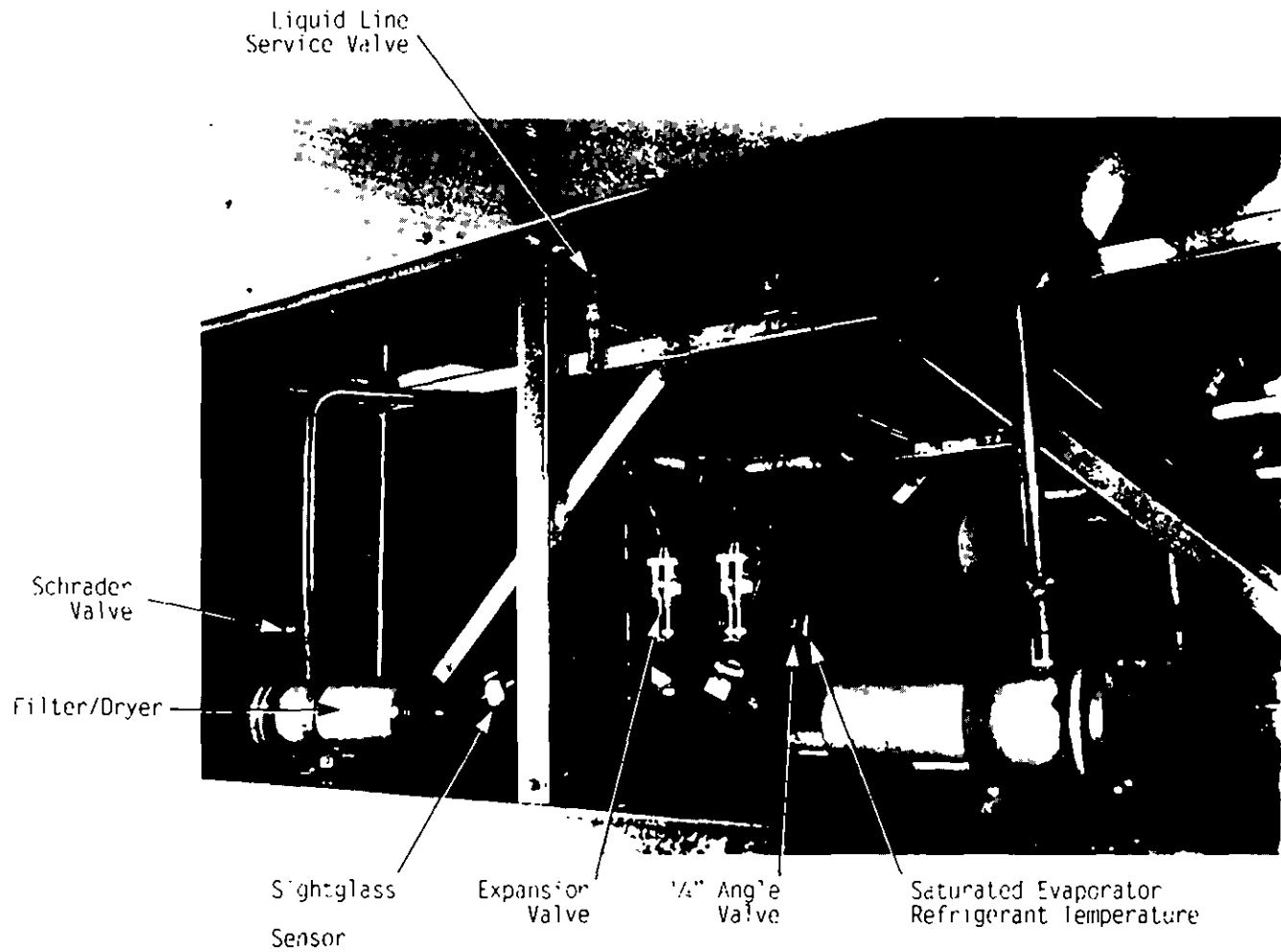
Figures 1 thru 3 show typical RTAA packaged units and their components. Tables 1 and 2 contain general RTAA mechanical specifications. Chilled water inlet and outlet openings are covered for shipment. Each circuit has a separate compressor motor starter.



**Figure 1**  
**Typical RTAA Packaged Unit**  
**70 – 125 Ton**  
**(Front/Side Exterior View)**



**Figure 2**  
**Typical RTAA Packaged Unit**  
**70 – 125 Ton**  
**(Rear Exterior View)**



**Table 1**  
**General RTAA Mechanical Specifications**

	Size					
	70	80	90	100	110	125
<b>Compressor</b>						
Quantity	2	2	2	2	2	2
Nominal Size (Tons)(1)	35/35	40/40	50/40	50/50	60/50	60/60
<b>Evaporator</b>						
Water Storage(Gallons)	39.8	37.8	34.4	32.1	53.4	45.8
(Liters)	150.6	143.1	130.2	121.5	202.1	173.4
Min. Flow (GPM)	84	96	108	120	132	150
(L/Sec)	5.3	6.1	6.8	7.6	8.3	9.5
Max. Flow (GPM)	252	288	324	360	396	450
(L/Sec)	15.9	18.2	20.4	22.7	25.0	28.4
<b>Condenser</b>						
Qty of Coils	4	4	4	4	4	4
Coil length (Ft.)(1)	13/13	13/13	14/13	14/14	17/14	17/17
Coil Height (In)	42	42	42	42	42	42
Number of Rows	2	2	2	2	2	2
<b>Condenser Fans</b>						
Quantity (1)	4/4	4/4	5/4	5/5	5/5	5/5
Diameter (In)	30	30	30	30	30	30
Total Airflow (CFM)	68,380	68,380	73,365	78,355	82,950	87,550
Nominal RPM	855	855	855	855	855	855
Tip Speed (Ft/Min)	6715	6715	6715	6715	6715	6715
Motor HP (Ea)	1.1	1.1	1.1	1.1	1.1	1.1
<b>Min Starting/Oper. Ambient</b>						
Std Unit (Deg. F)	15	15	15	15	15	15
Low Amb. (Deg. F)	-10	-10	-10	-10	-10	-10
<b>General Unit</b>						
Refrigerant	HCFC-22	HCFC-22	HCFC-22	HCFC-22	HCFC-22	HCFC-22
No. of Independent Refrigerant Circuits	2	2	2	2	2	2
% Min. Load(3)	10	10	10	10	10	10
Refrig Charge (Lb)(1)	58/58	61/61	73/61	73/73	98/73	98/98
(Kg)	26/26	27/27	33/27	33/33	44/33	44/44
Oil Charge (Qts)(1,4)	10/10	10/10	12/10	12/12	12/12	12/12
(l)	10.6/10.6	10.6/10.6	12.7/10.6	12.7/12.7	12.7/12.7	12.7/12.7

**Notes**

- 1 Data containing information on two circuits shown as follows: ckt1/ckt2
- 2 Minimum start-up/operating ambient based on a 5 mph wind across the condenser
- 3 Percent minimum load is for total machine, not each individual circuit
- 4 Trane Part Change # Oil-31 (see service bulletin SCOM SB-1)

**Table 2  
RTAA Refrigerant Circuit Designations and Capacities**

RTAA Model	Circuit / Tons	Compressor /
70	1 35	A 35
	2 35	B 35
80	1 40	A 40
	2 40	B 40
90	1 50	A 50
	2 40	B 40
100	1 50	A 50
	2 50	B 50
110	1 60	A 60
	2 50	B 50
125	1 62.5	A 60
	2 62.5	B 60

Package Unit 70-125

COND 1	EVAP 1	A	P N I
COND 2	EVAP 2	B	

The RTAA series features Trane's exclusive Adaptive Control™ logic with Clear Language Display. It monitors the control variables that govern the operation of the chiller unit. Adaptive Control logic can adjust these variables, when necessary, to optimize operational efficiencies, avoid chiller shutdown, and keep producing chilled water. An optional remote display is available to monitor unit operation from a remote location.

These dual-compressor units feature two independent circuits, one for each compressor. Compressor unloaders are solenoid actuated. Each refrigerant circuit is provided with filter drier, sight glass, electronic expansion valve, and charging valves.

The shell-and-tube type evaporator is manufactured in accordance with ASME standards. The evaporator is fully insulated and is equipped with water drain and vent connections. Packaged units have heat tape protection to -20 F.

## Commonly Used Acronyms

Acronyms used in this manual are defined below.

**BAS** = Building Automation System  
**BCL** = Bidirectional Communications Link  
**CAR** = Circuit Shutdown, Auto Reset  
**CMR** = Circuit Shutdown, Manual Reset  
**CLD** = Clear Language Display  
**CLS** = Current Limit Setpoint  
**CWR** = Chilled Water Reset  
**CWS** = Chilled Water Setpoint  
**DDT** = Design Delta-Temperature Setpoint (i.e., the difference between entering and leaving chilled water temperatures)  
**ENT** = Entering Chilled Water Temperature  
**EXV** = Electronic Expansion Valve  
**FLA** = Full Load Amps  
**HGBP** = Hot Gas Bypass  
**HVAC** = Heating, Ventilating and Air Conditioning  
**IFW** = Informational Warning  
**I/O** = Input and Output Wiring  
**LPC** = Low Pressure Cutout  
**LRTC** = Low Refrigerant Temperature Cutout

**LRA** = Locked Rotor Amps  
**LVG** = Leaving Chilled Water Temperature  
**MAR** = Machine Shutdown, Auto Reset  
**MMR** = Machine Shutdown, Manual Reset  
**NEC** = National Electric Code  
**OAT** = Outdoor Air Temperature  
**PCWS** = Front Panel Chilled Water Setpoint  
**PFCC** = Power Factor Correction Capacitors  
**PSID** = Pounds-per-Square-inch Differential (pressure differential)  
**PSIG** = Pounds-per-Square-inch (gauge pressure)  
**PWM** = Pulse Width Modulation  
**RAS** = Reset Action Setpoint  
**RLA** = Rated Load Amps  
**RCWS** = Reset Chilled Water Setpoint (CWR)  
**RRS** = Reset Reference Setpoint (CWR)  
**SV** = Slide Valve  
**Tracer** = Type of Trane Building Automation System  
**SCI** = Serial Communications Interface  
**UCLS** = Unit Current Limit Setpoint  
**UCM** = Unit Control Module (Microprocessor-based)  
**UCWS** = Unit Chilled Water Setpoint

---

## Warnings and Cautions

**Warnings and Cautions** appear in **boldface** type at appropriate points in this manual

**Warnings** are provided to alert personnel to potential hazards that can result in personal injury or death.

**Cautions** alert personnel to conditions that could result in equipment damage

Your personal safety and reliable operation of this machine depend upon strict observance of these precautions. The Trane Company assumes no liability for installation or service procedures performed by unqualified personnel

## Installation Responsibilities

Generally, the contractor must install the unit per the instructions contained in the "Installation - Mechanical" and "Installation - Electrical" sections of this manual, including the following:

- [ ] Install unit on a flat foundation, level (within 1/4" [6.4 mm]), and strong enough to support unit loading
- [ ] Install any options and make electrical connections at the UCM.

### For remote evaporator units only

Furnish and install refrigerant piping, refrigerant, and oil, per instructions outlined in this manual.

**Note:** The standard leaving chilled water sensor is factory installed in the evaporator leaving water outlet.

## Nameplates

The RTAA outdoor unit nameplates (Figure 3) are applied to the exterior and interior surface of the Control Panel door (Figure 1). A compressor nameplate is located on each compressor.

## Outdoor Unit Nameplate

The outdoor unit nameplate provides the following information:

- Unit model and size descriptor
- Unit serial number
- Identifies unit electrical requirements
- Lists correct operating charges of R-22 and refrigerant oil.
- Lists unit test pressures.
- Identifies installation, operation and maintenance and service data literature.
- Lists drawing numbers for unit wiring diagrams.

## Compressor Nameplate

The "compressor" nameplate provides the following information:

- Compressor model number.
- Compressor serial number.
- Compressor electrical characteristics.
- Utilization Range.
- Recommended refrigerant.

## ASME Nameplate

This nameplate is affixed to the top of the suction side of the evaporator head and provides the following information.

- ASME national board number
- maximum temperature
- maximum working pressure

Figure 3  
Nameplates



\*\*\* SERIES B AIR COOLED CHILLER \*\*\*  
FOR OUTDOOR USE

---

MODEL NO: RTAA1104ED01A1BEO                      SERIAL NO: U93F15594

RATED VOLTAGE: 460 VOLTS 3 PH 60 HZ

VOLTAGE UTILIZATION RANGE: 414-506 VAC

MINIMUM CIRCUIT CAPACITY: 735 AMPS

RECOMMENDED DUAL ELEMENT FUSE: 300 AMPS  
MAXIMUM FUSE: 300 AMPS

MAXIMUM CIRCUIT BREAKER: 300 AMP - CANADIAN INSTALLATION (CSA) ONLY

	QTY	VOLTS	PH	HZ	RLA	GRA
COMPRESSOR MOTOR A:	1	460	3	60	101.0	545.0
COMPRESSOR MOTOR B:	1	460	3	60	84.0	420.0
COMPRESSOR FAN MOTORS:	10	460	3	60	FLA(EA): 2.5 HP(EA):1.50	
CONTROL CIRCUIT:	1	115	1	60	VA MAX: 750	
EVAPORATOR HEAT TAPE:	1	115	1	60	VA MAX: 420	

---

REFRIGERANT SYSTEM FACTORY CHARGED WITH REFRIGERANT R-22  
CIRCUIT 1: 90 LBS.                      CIRCUIT 2: 75 LBS.

LUBRICATION SYSTEM FACTORY CHARGED WITH TRANE OIL NO. 15  
CIRCUIT 1: 3.0 GALS.                      CIRCUIT 2: 3.0 GALS.

REFRIG. SIDE FACTORY TEST PRESSURE: 450 PSIG (HIGH) 300 PSIG (LOW)

---

FOR SERVICE INFORMATION REFER TO THE FOLLOWING TRANE LITERATURE:

INSTALLATION, OPERATION & MAINTENANCE: RTAA-IOM  
WIRING INFORMATION: RTAA-W  
WIRING DIAGRAMS Page 1: 2307-3327  
Page 2: 2307-3328  
Page 3: 2307-3329  
Page 4: 2307-3330  
Page 5: 2307-3331

FIELD WIRING: 2307-3325  
COMPRESSOR LOCATION: 230-5120

MANUFACTURED UNDER ONE OR MORE OF THE FOLLOWING U.S. PATENTS/  
CORRESPONDING FOREIGN PATENTS OWNED BY AMERICAN STANDARD INC.:

4,643,694 4,689,967 4,715,190 4,751,653 4,987,749 5,000,009  
5,009,075 5,027,608 5,056,032 5,056,594 5,050,031 5,067,560  
5,123,296 5,138,844 5,203,685 5,211,026

 <b>HELIUSTOR™ COMPRESSOR</b>	SERIAL NUMBER
	MODEL NUMBER
ELECTRICAL CHARACTERISTICS	
LOCKED MOTOR CURRENT, VYE CONNECTION	
LOCKED MOTOR CURRENT, DELTA CONNECTION	
UTILIZATION RANGE	REFRIGERANT
THERMALLY PROTECTED SYSTEM	
<small>MANUFACTURED UNDER ONE OR MORE OF THE FOLLOWING U.S. PATENTS/          FOREIGN COUNTERPARTS OF AMERICAN STANDARDS OR ITS LICENSEE          SVENSKA ROTOR MASKINER AB 36268 4 642308 457336          4,622,848 4,622,190 4,764,469 4,957,317 4,642,654</small>	
<small>The Trane Company, La Crosse, WI 54601-7899 U.S.A.</small>	

## Model Number Coding System

The model numbers for the unit and the compressors are comprised of numbers and letters which represent features of the equipment. Shown on the chart in Figure 4 are samples of typical unit model numbers, followed by the coding system.

**Figure 4**  
**Model Number Coding System**  
The Series R unit model number is as follows:

**Model Number:**  
Dig.1 Number

Each position, or group of positions, in the number is used to represent a feature. For example, in Figure 4, position 8 of the unit model number, Unit Voltage, contains the number "4". From the chart, it can be seen that a "4" in this position means that the unit voltage is 460/60/3

## Storage

Extended storage of the outdoor unit prior to installation requires the following precautionary measures.

1. Store the outdoor unit in a secure area
2. At least every three months (quarterly), check the pressure in the refrigerant circuits to verify that the refrigerant charge is intact. If it is not, contact a qualified service organization and the appropriate Trane sales office.

**RTA A 070 4 Y A0 1 B 1 D A Q**

0 1 2  
1 2 3 4 5 6 7 8 9 0 1 2 3 4 5 6 0 (DIGIT POSITION FOR ABOVE)

### Digit 01, 02 Unit Model

RT = Rotary Chiller

### Digit 03 Unit Type

A = Air Cooled

### Digit 04 Development Sequence

A = First Sequence

### Digits 05, 06, 07 Nominal Capacity

070 = 70 Nominal Tons  
080 = 80 Nominal Tons  
090 = 90 Nominal Tons  
100 = 100 Nominal Tons  
110 = 110 Nominal Tons  
125 = 125 Nominal Tons

### Digit 08 Unit Voltage

D = 380/60/3  
A = 200/60/3  
C = 230/60/3  
J = 346/50/3  
4 = 460/60/3  
5 = 575/60/3  
S = Special

### Digit 09 Compressor Starter Type

Y = Y-Delta Closed Transition  
X = X-Line (Across the Line)  
S = Special

### Digits 10, 11 Design Sequence

AO = First Sequence (Factory Input)

### Digit 12 Evaporator Leaving Temperature

1 = Standard 40 to 65 F  
2 = Low 0 to 39 F  
3 = Ice-Making 20 to 65 F  
S = Special

### Digit 13 Condenser Coil Fin Material

A = Aluminum  
B = Blue Fin Coil Protection  
S = Special

### Digit 14 Agency Listing

0 = No Agency Listing  
1 = UL Listing  
2 = C S A Listing

### Digit 15 Control Interface

C = Deluxe without Communication  
D = Deluxe with Communication

### Digit 16 Chilled Water Reset

0 = No Chilled Water Reset  
1 = Based on Return Water Temperature  
2 = Based on Outside Air Temperature  
3 = Based on Zone Temperature

### Digit 17 Miscellaneous Factory Installed Options

A = Architectural Louvered Panels (factory)  
B = Control Power Transformer (factory)  
D = Low Ambient Lockout Sensor (factory)  
F = Power Disconnect (factory)  
G = Low Ambient Operation (factory)  
J = Remote Evaporator  
K = Coil Protection (factory)  
M = Access Guard (factory)  
N = Neoprene Isolators (field)  
O = Spring Isolators (field)  
R = Remote Display Panel (field)

# Installation – Mechanical Packaged Unit and Units with Remote Evaporator Option

---

## General

The following instructions are applicable to 70 to 125-ton packaged units.

## Pre-Installation

Report any damage incurred during handling or installation to the Trane sales office immediately. An Installation Check Sheet is provided on Page 36.

## Foundation

Provide rigid, non-warping mounting pads or a concrete foundation of sufficient strength and mass to support the outdoor unit operating weight (i.e., including completed piping, and full operating charges of refrigerant, oil and water). Refer to Figure 7 for unit operating weights. Once in place, the outdoor unit must be level within 1/4" (6.4 mm) over its length and width. The Trane Company is not responsible for equipment problems resulting from an improperly designed or constructed foundation.

## Location Requirements

### Noise Considerations

Locate the outdoor unit away from sound-sensitive areas. If required, install rubber vibration isolators in all water piping and use flexible electrical conduit. Refer to "Unit Isolation". Consult an acoustical engineer for critical applications. Also refer to Trane Engineering Bulletins for application information on RTAA chillers.



**Figure 5**  
**RTAA Rigging and Lifting Weights – Packaged Unit**

UNIT SIZE	LIFTING WEIGHTS						TOTAL WEIGHTS	CG LOCATIONS		
	W1	W2	W3	W4	W5	W6		X	Y	
70	491kg (1083)	452kg (996)	500kg (1103)	460kg (1015)	510kg (1124)	489kg (1034)	2733kg (6025)	3.216m (126.6')	1.072m (42.2')	
80	497kg (1082)	452kg (996)	501kg (1105)	467kg (1017)	512kg (1128)	471kg (1038)	2745kg (6051)	3.211m (126.4')	1.072m (42.2')	
90	503kg (1109)	472kg (1040)	519kg (1145)	487kg (1074)	536kg (1182)	503kg (1108)	2890kg (6372)	3.190m (125.6')	1.082m (42.6')	
100	515kg (1135)	475kg (1047)	532kg (1173)	491kg (1082)	549kg (1211)	507kg (1117)	2947kg (6496)	3.185m (125.4')	1.074m (42.5')	
110	528kg (1164)	533kg (1175)	553kg (1220)	559kg (1232)	579kg (1278)	585kg (1289)	3134kg (6910)	3.454m (136.0')	1.125m (44.3')	
125	541kg (1192)	530kg (1169)	577kg (1273)	568kg (1248)	614kg (1353)	602kg (1327)	3230kg (7180)	3.418m (134.6')	1.109m (43.7')	

- NOTES:
1. LIFTING CHAINS (CABLES) WILL NOT BE THE SAME LENGTH. ADJUST TO KEEP UNIT LEVEL WHILE LIFTING.
  2. DO NOT FORK LIFT UNIT.
  3. WEIGHTS ARE TYPICAL FOR UNITS WITH R-22 CHARGE.
  4. WEIGHTS IN ( ) ARE LBS.
  5. DO NOT PUSH UNIT WITH A FORKLIFT.

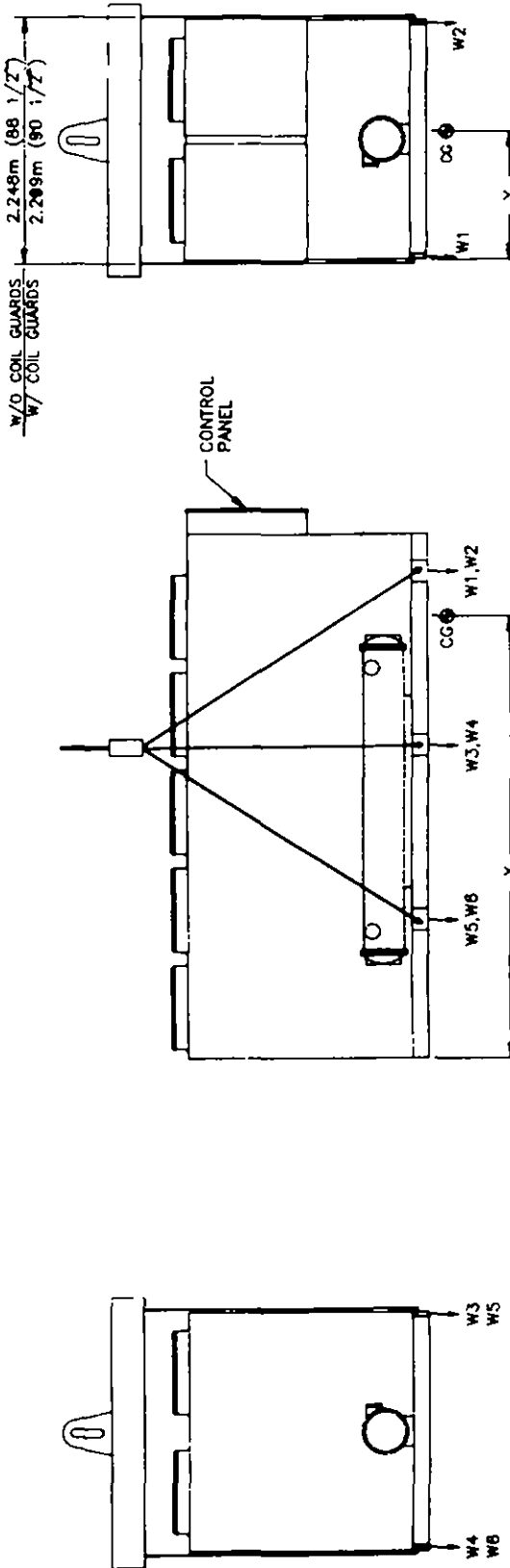
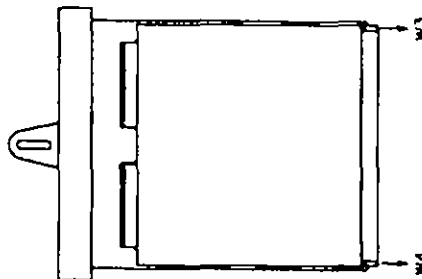
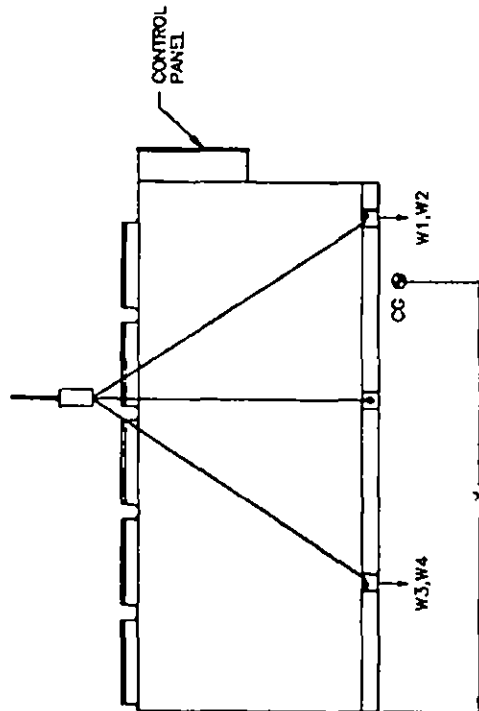
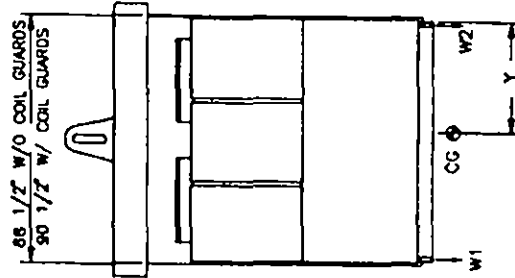


Figure 5a  
RTAA Rigging and Lifting Weights – Remote Evaporator

UNIT SIZE	LIFTING WEIGHTS								TOTAL WEIGHTS	CG LOCATIONS		
	W1	W2	W3	W4	W5	W6	W6	X		Y		
70	346 (763)	309 (681)	441 (972)	393 (867)	535 (1180)	477 (1052)	2502 (5515)	3408.1 (134.1)	1038.6 (41.6)			
80	348 (763)	309 (681)	441 (972)	393 (867)	535 (1180)	477 (1052)	2502 (5515)	3408.1 (134.1)	1038.6 (41.6)			
90	369 (813)	337 (743)	458 (1009)	418 (921)	547 (1205)	498 (1099)	2628 (5790)	3385.8 (133.3)	1069.3 (42.1)			
100	380 (837)	340 (750)	468 (1034)	420 (927)	559 (1232)	501 (1104)	2669 (5885)	3383.3 (133.2)	1059.2 (41.7)			
110	375 (827)	373 (822)	467 (1030)	484 (1024)	556 (1225)	556 (1225)	2794 (6160)	3895.7 (145.5)	1117.8 (44.0)			
125	403 (809)	387 (853)	488 (1077)	469 (1033)	574 (1265)	551 (1214)	2871 (6330)	3687.8 (144.4)	1097.3 (43.2)			

- NOTES:
1. LIFTING CHAINS (CABLES) WILL NOT BE THE SAME LENGTH. ADJUST TO KEEP UNIT LEVEL WHILE LIFTING.
  2. DO NOT FORK LIFT UNIT.
  3. WEIGHTS ARE TYPICAL FOR UNITS WITHOUT R-22 CHARGE.
  4. DIMENSIONS IN ( ) ARE IN INCHES
  5. WEIGHTS IN ( ) ARE IN POUNDS



RTAA-SA-2024A

---

## Clearances

Provide enough space around the outdoor unit to allow the installation and maintenance personnel unrestricted access to all service points. Refer to submittal drawings for the unit dimensions, to provide sufficient clearance for the opening of control panel doors and unit service. Refer to Figure 6 for minimum clearances. In all cases, local codes which require additional clearances will take precedence over these recommendations.

**Note:** If the outdoor unit configuration requires a variance to the clearance dimensions, contact your Trane Sales Office Representative. Also refer to Trane Engineering Bulletins for application information on RTAA chillers

## Additional Location Requirements for Remote Evaporator Only

The Remote evaporator must be installed indoors, unless:

- The ambient temperature is always greater than 32 F.
- The system circulating liquid is a non-freezing glycol-type solution, selected for the prevailing ambient temperature.
- The evaporator is protected from freezing by properly installed and applied insulation and heat tape.

**Caution: To prevent damage due to freezing, do not install the unit outside without adequate freeze protection.**

The remote evaporator should be mounted on a base of suitable strength to support the operating weight. Remote evaporator weights and mounting locations are shown in Figure 5a.

The remote evaporator must be level when installed. Be sure to allow adequate clearance for water and refrigerant piping connection, performance of service procedures, reading of gauges and thermometers, and operation of valves. Space must be allowed at one end of the evaporator to pull tubes, if required

## Rigging

The Model RTAA chiller should be moved by lifting. Refer to Figure 5 for typical unit lifting and weights. Refer to the rigging diagram that ships with each unit for specific "per unit" weight data.

---

**WARNING: To prevent injury or death and unit damage, capacity of lifting equipment must exceed unit lifting weight by an adequate safety factor.**

---

## Lifting Procedure

**Caution: To prevent damage do not use a forklift to lift or push the unit.**

- [ ] Install chains and safety chains through the six lifting plates provided on the unit (Figure 5).

---

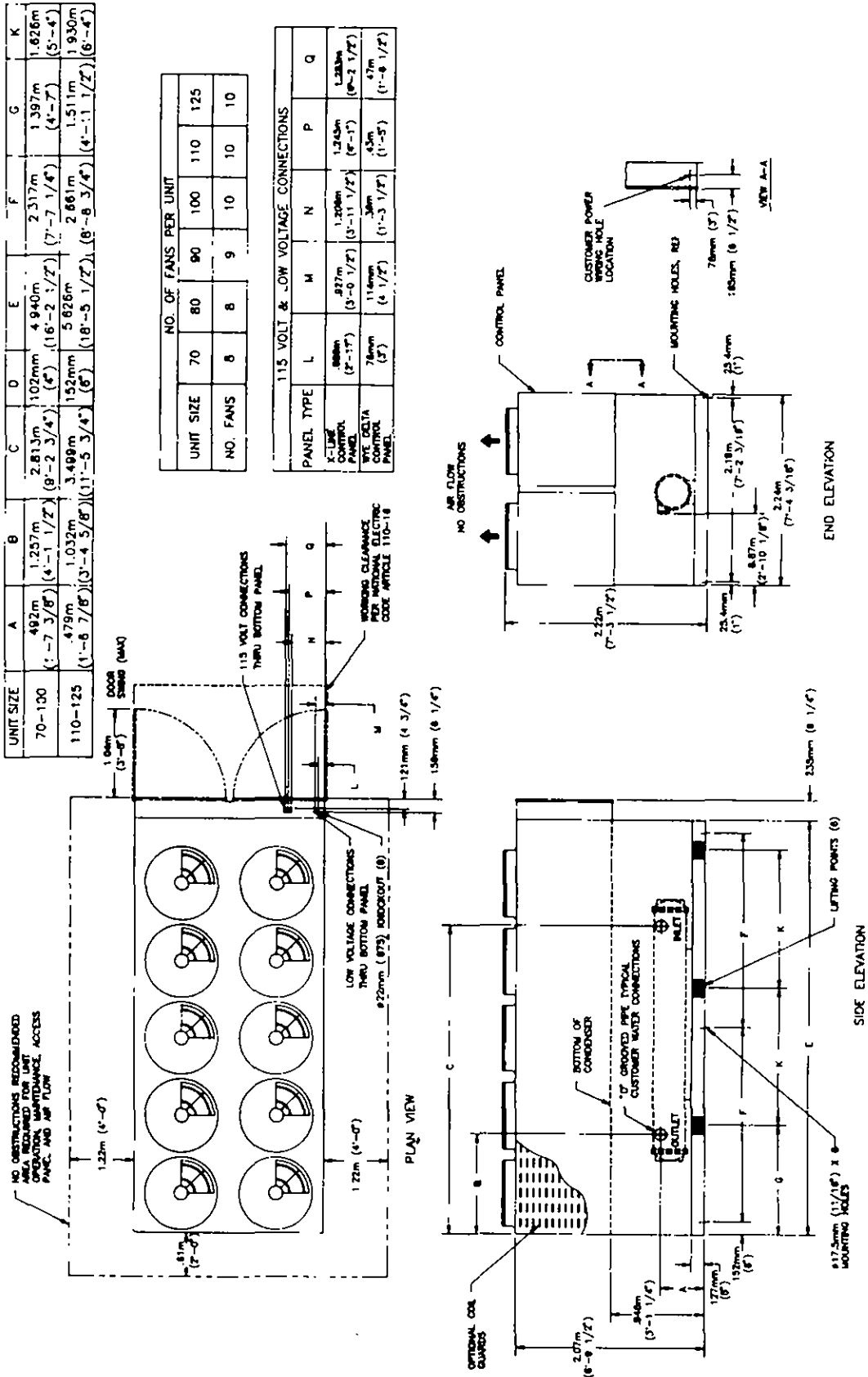
**WARNING: To prevent injury or death and unit damage, use the lifting method shown in Figure 5.**

---

- [ ] Attach lifting chains or cables to the chains installed above. Each cable alone must be strong enough to lift the chiller.
- [ ] Attach cables to lifting beam. Total lifting weight, lifting weight distribution and required lifting beam dimensions are shown in Figure 5 and on the rigging diagram shipped with each unit. Lifting beam crossbars must be positioned so lifting cables do not contact the sides of the unit.

**Caution: To prevent unit damage, position lifting beam so that cables do not contact the unit.**

### Figure 6 Dimensions and Clearances for RTAA Packaged Unit 70 – 125 Tons



**Figure 6a**  
**Dimensions and Clearances for RTAA with Remote Evaporator**  
**70 - 125 Tons**

NO. OF FANS PER UNIT		115 VOLT & LOW VOLTAGE CONNECTIONS												
UNIT SIZE	70-80	90	100-125	L	M	N	P	Q	E	F	G	H	J	K
70-80	8	9	10	2'-0" (609.6)	3'-0" (914.4)	3'-11" (1206.5)	4'-1" (1244.6)	4'-2" (1282.7)	16'-2" (4940.3)	7'-7" (2317.8)	4'-7" (1397.0)	8'-0" (2438.4)	5'-3" (1600.2)	5'-4" (1625.6)
90	8	9	10	2'-0" (609.6)	3'-0" (914.4)	3'-11" (1206.5)	4'-1" (1244.6)	4'-2" (1282.7)	18'-5" (5626.1)	8'-8" (2667.2)	4'-11" (1511.3)	10'-0" (3048.0)	6'-5" (1955.8)	6'-4" (1930.4)
100-125	8	9	10	2'-0" (609.6)	3'-0" (914.4)	3'-11" (1206.5)	4'-1" (1244.6)	4'-2" (1282.7)	18'-5" (5626.1)	8'-8" (2667.2)	4'-11" (1511.3)	10'-0" (3048.0)	6'-5" (1955.8)	6'-4" (1930.4)

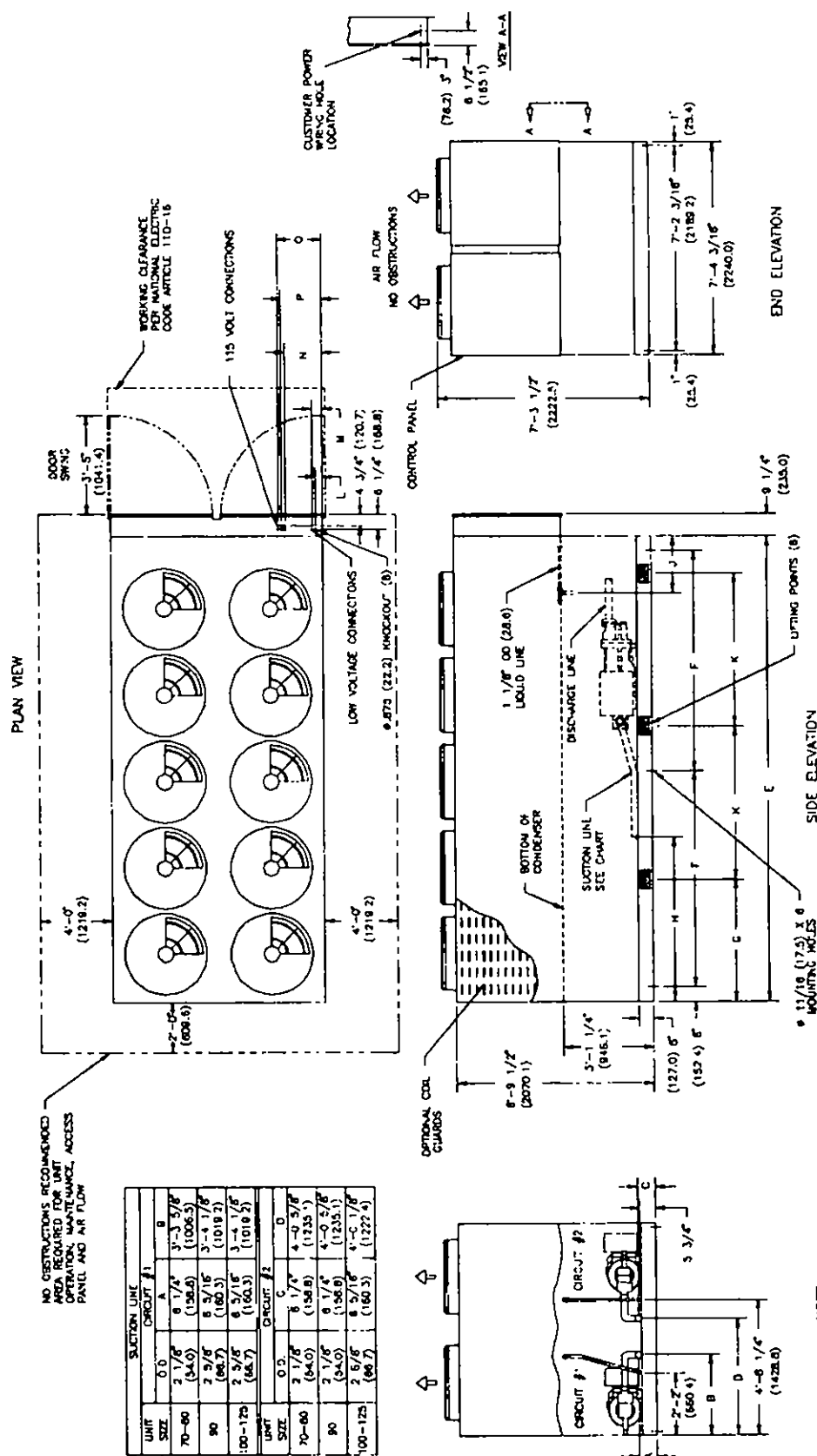
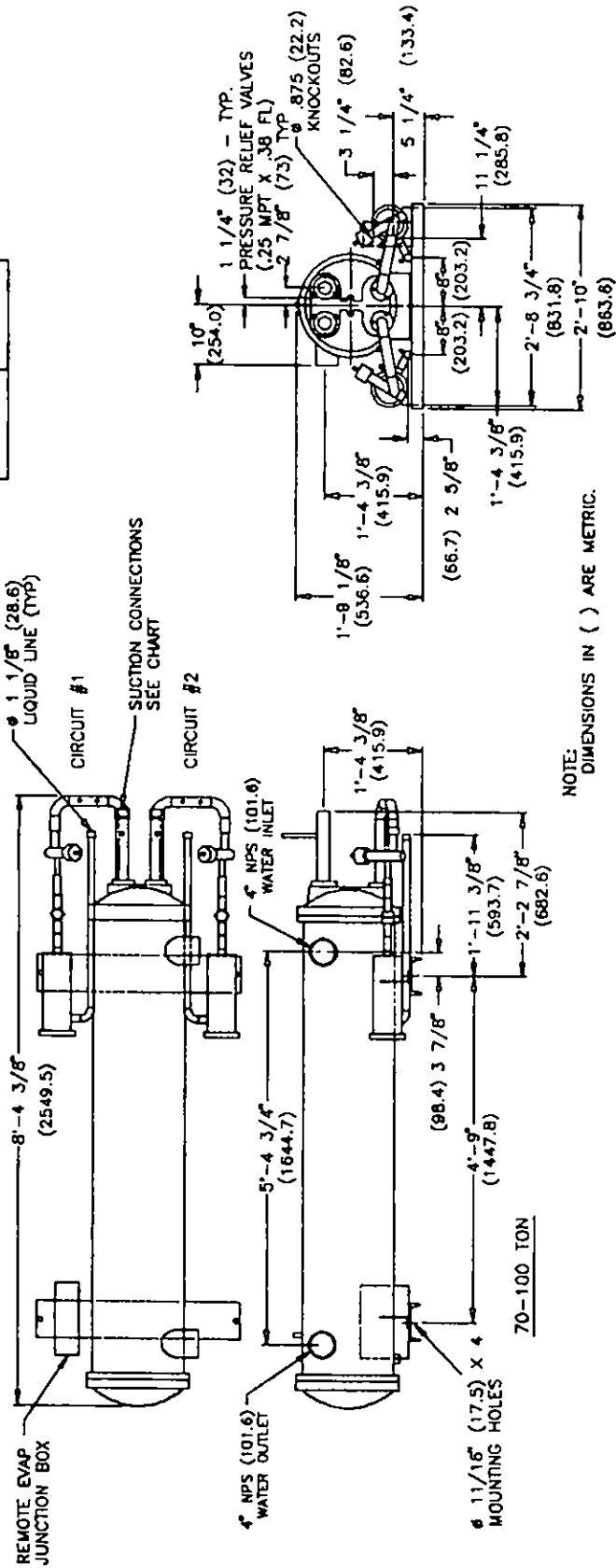


Figure 6b  
Remote Evaporator Dimensions,  
RTAA 70 - 100 Tons

EVAPORATOR WEIGHTS	
UNIT SIZE	LBS.
70	710
80	731
90	764
100	796

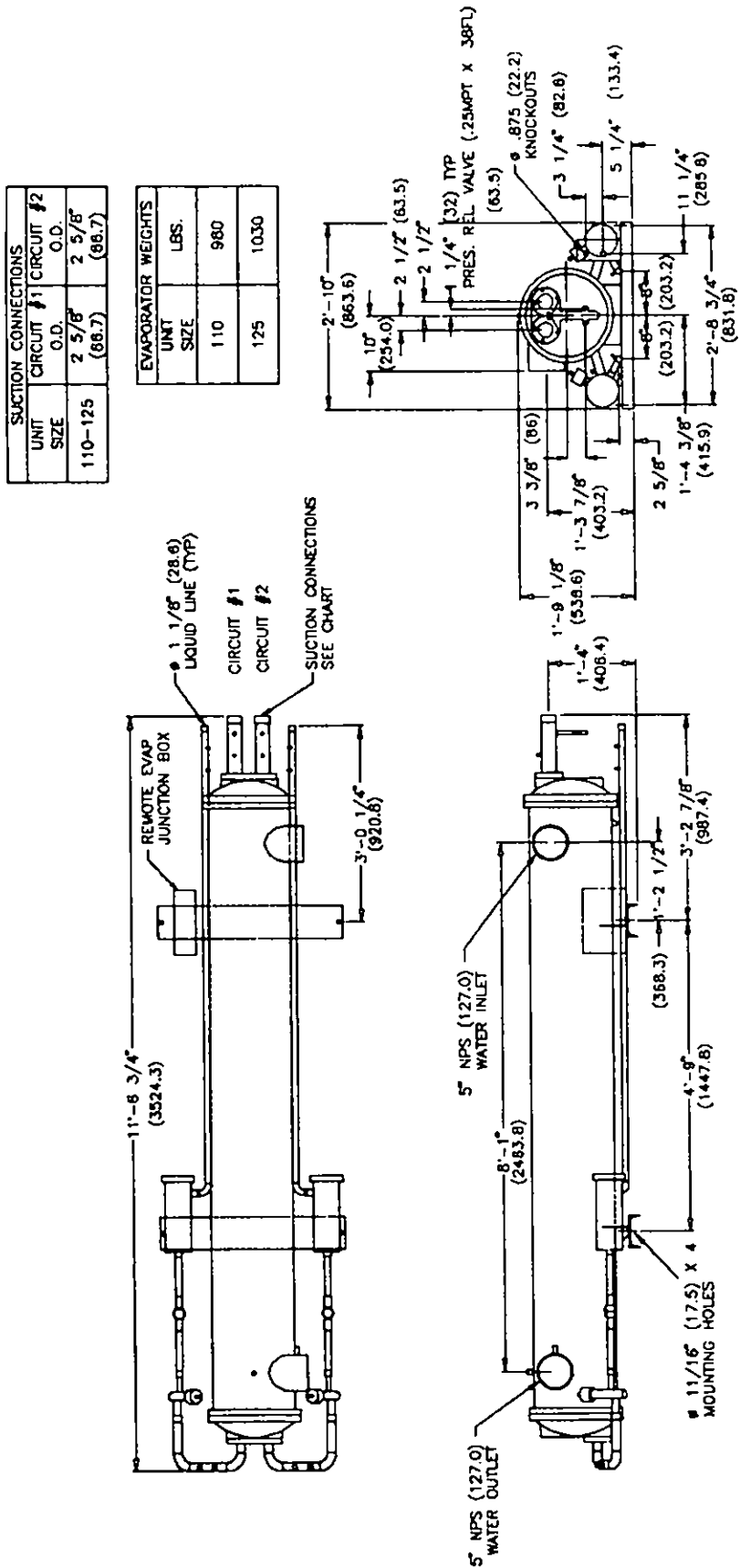
SUCTION CONNECTIONS		
UNIT SIZE	CIRCUIT #1 O.D.	CIRCUIT #2 O.D.
70-80	2 1/8" (54.0)	2 1/8" (54.0)
90	2 5/8" (66.7)	2 1/8" (54.0)
100	2 5/8" (66.7)	2 5/8" (66.7)



NOTE:  
DIMENSIONS IN ( ) ARE METRIC.

RTAA-SU-1012C

**Figure 6c**  
**Remote Evaporator Dimensions,**  
**RTAA 110 - 125 Tons**



RTAA-SU-1013A

---

## Unit Isolation

There are two mounting methods that will minimize sound and vibration problems. They are the direct-mount method and the isolator-mount method.

### Direct Mounting

The unit can be direct-mounted on an isolated concrete pad or on isolated concrete footings at each mounting location. Refer to Figure 7 for unit operating weights. A mounting hole is provided in the base of the unit frame at each mounting location. Provide a means of securely anchoring the unit to the mounting surface. Level the unit carefully. Refer to "Unit Leveling".

### Isolator Mounting

If the unit is installed using the optional neoprene or spring isolators, use one of the mounting methods that follow:

#### Neoprene Isolators

Install the optional neoprene mounting isolators at each mounting location. Refer to Figure 7 for isolator selection, placement and loading information. Isolators are identified by color and by the isolator part number.

Bolt the isolators to the mounting surface. Do not fully tighten the mounting bolts. Mount the unit on the isolators and install a 1/2" (13 mm) nut on each isolator positioning pin. Maximum isolator deflection should be approximately 1/4-inch. Level the unit carefully. Refer to "Unit Leveling". Now fully tighten isolator mounting bolts.

#### Spring Isolators (Packaged Chillers Only)

Install the optional spring-type isolators at each mounting point. The isolator springs are color-coded to help identify the proper isolator. Refer to Figure 7 for isolator selection, placement and loading information.

Bolt the isolators to the mounting surface. Do not fully tighten the isolator mounting bolts.

Mount the unit on to the isolators. Clearances between the top plate and the lower housing of each isolator should be 1/4 to 1/2-inch. Make minor adjustments by turning the isolator leveling bolt. A 1/4-inch variance in elevation is acceptable.

Install a 1/2" (13 mm) nut on each isolator positioning pin.

## Unit Leveling

Before snugging down the mounting bolts, level the unit carefully. Check unit level end-to-end by placing a level on the top surface of the unit frame. Unit should be level to within 1/4-inch (6.35 mm) over its length. Place the level on the unit frame to check front-to-back level. Adjust to within 1/4" (6.35 mm) of level front-to-back. Use the adjustable spring isolators or shims to level the unit.

## Water Piping

Thoroughly flush all water piping to the unit before making the final piping connections to the unit.

**Caution: If using an acidic commercial flushing solution, construct a temporary bypass around the unit to prevent damage to internal components of the evaporator.**

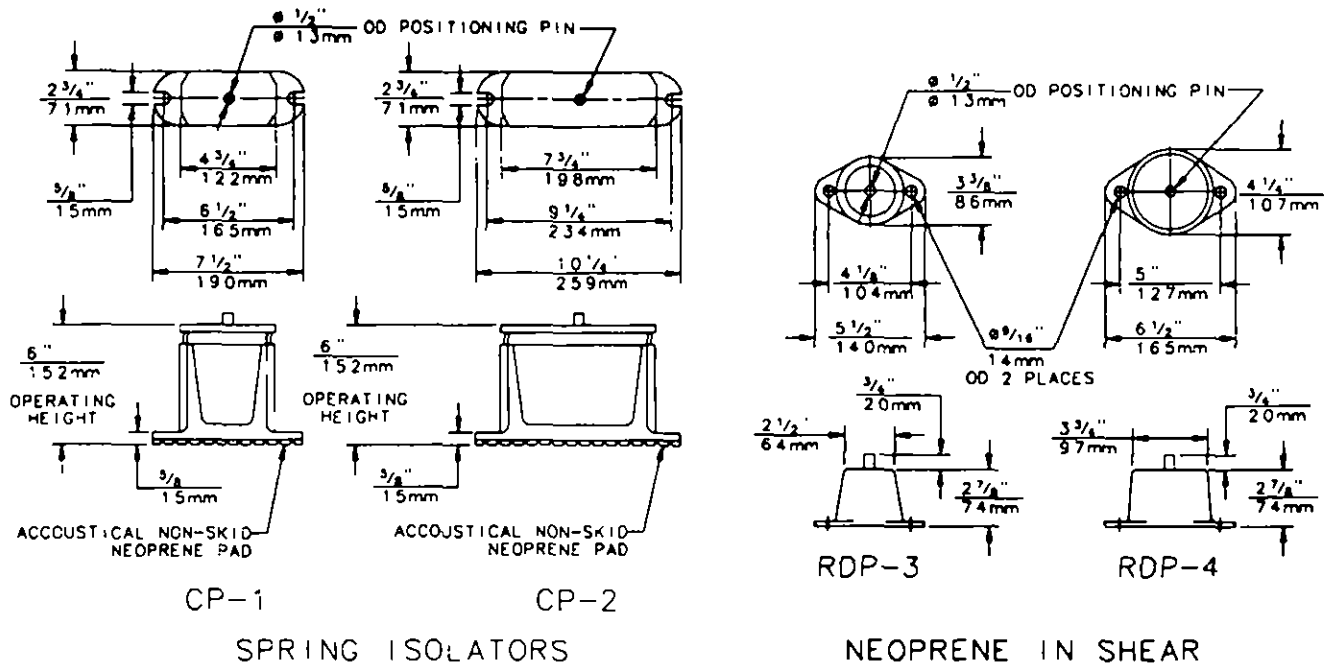
**Caution: To avoid possible equipment damage, do not use untreated or improperly treated system water.**

When completing the NPT-type water connections, apply a suitable pipe sealant, or Teflon tape, to prevent water leakage. To minimize heat gain and to prevent condensation, insulate all piping.

**Caution: Avoid overtightening and possible damage of water connections. The lubricating properties of Teflon tape make the possibility of overtightening more likely.**

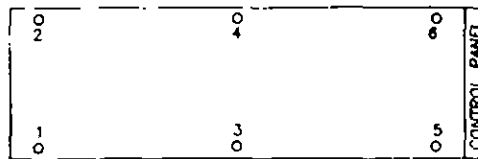


**Figure 7**  
**Isolator Placement for**  
**Typical RTAA Packaged Unit**  
**70 - 125 Tons**



UNIT	MOUNTING LOCATIONS AND ISOLATOR PART NUMBER						UNIT	MOUNTING LOCATIONS AND NEOPRENE PART NUMBER					
	LOCATION 1	LOCATION 2	LOCATION 3	LOCATION 4	LOCATION 5	LOCATION 6		LOCATION 1	LOCATION 2	LOCATION 3	LOCATION 4	LOCATION 5	LOCATION 6
70-100	CP-1-31	CP-1-31	CP-2-28	CP-2-28	CP-2-32	CP-2-32	70-125	RDP-3 GRAY	RDP-3 GRAY	RDP-4 BLK	RDP-4 BLK	RDP-4 RED	RDP-4 RED
110-125	CP-1-32	CP-1-32	CP-2-31	CP-2-31	CP-2-32	CP-2-32							

**SPRING COLOR**  
 28 - GRFIN  
 31 - GRAY  
 32 - WHITE

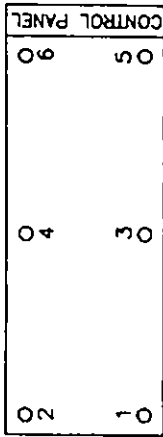


UNIT	WEIGHT ON ISOLATOR AT MOUNTING LOCATION					
	LOCATION 1	LOCATION 2	LOCATION 3	LOCATION 4	LOCATION 5	LOCATION 6
70	279kg (615)	256kg (565)	500kg (1103)	460kg (1015)	722kg (1592)	864kg (1464)
80	280kg (617)	258kg (568)	501kg (1105)	461kg (1017)	723kg (1594)	865kg (1466)
90	294kg (648)	278kg (608)	519kg (1145)	487kg (1074)	745kg (1643)	899kg (1540)
100	302kg (665)	278kg (613)	532kg (1173)	491kg (1082)	762kg (1681)	704kg (1551)
110	375kg (828)	379kg (836)	553kg (1220)	559kg (1232)	731kg (1611)	738kg (1628)
125	399kg (880)	391kg (863)	577kg (1273)	566kg (1248)	756kg (1666)	741kg (1633)

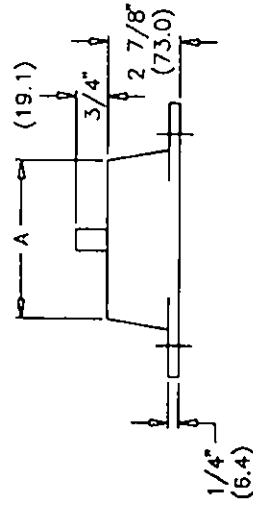
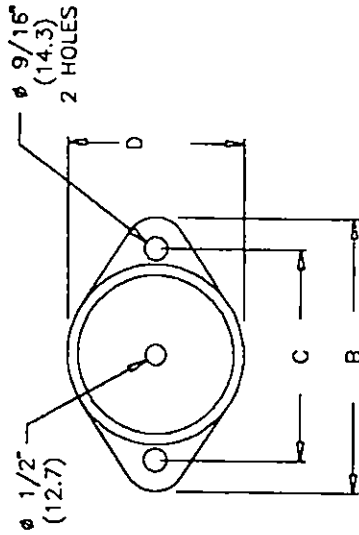
WEIGHTS IN ( ) ARE LBS

Figure 7a  
Isolator Placement for RTAA  
with Remote Evaporator

MOUNTING LOCATIONS AND ISOLATOR PART NUMBER						
UNIT SIZE	LOC 1	LOC 2	LOC 3	LOC 4	LOC 5	LOC 6
70-125	RDP-3 RED	RDP-3 RED	RDP-3 GRAY	RDP-3 GRAY	RDP-4 RED	RDP-4 RED



UNIT SIZE	MOUNTING WEIGHTS					
	LOC 1	LOC 2	LOC 3	LOC 4	LOC 5	LOC 6
	APPROX LBS					
70	382	341	972	867	1561	1392
80	382	341	972	867	1561	1392
90	412	376	1009	921	1606	1466
100	424	380	1034	927	1645	1474
110	518	515	1030	1024	1542	1532
125	559	536	1077	1033	1595	1531
	APPROX KG					
70	173	155	441	393	708	631
80	173	155	441	393	708	631
90	187	171	458	418	728	665
100	192	172	469	420	746	669
110	235	234	467	464	699	695
125	254	243	489	469	723	694



NOTE: DIMENSIONS IN ( ) ARE METRIC.

TYPE	COLOR	MAX LOAD EACH	DEFLECTION	MATERIAL	DIMENSIONS			
					A	B	C	D
RDP-3	RED	525 LBS 238 KG	.50 (12.7)	NEOPRENE	2.50 (63.5)	5.50 (139.7)	4.12 (104.6)	3.38 (85.9)
RDP-3	GRAY	1100 LBS 499 KG	.50 (12.7)	NEOPRENE	2.50 (63.5)	5.50 (139.7)	4.12 (104.6)	3.38 (85.9)
RDP-4	RED	2250 LBS 1020 KG	.50 (12.7)	NEOPRENE	3.75 (95.3)	6.50 (165.1)	5.00 (127.0)	4.25 (108.0)

RTAA-SU-1012C

## Evaporator Water Piping

### Evaporator Refrigerant Relief Valve Piping

Important. Vent pipe size must conform to the ANSI/ASHRAE Standard 15-1992 (or latest version) for vent pipe sizing. All federal, state, and local codes take precedence over any suggestions stated in this manual.

**Note:** All relief valve venting is the responsibility of the installing contractor.

The remote evaporators on chillers sold with this option utilize relief valves installed in each circuit of the evaporator head. There is one relief valve per circuit, and they must be vented to the outside of the building.

The relief valves are 3/8" SAE flare connections. They have a 300 psig relief setpoint, and relieve at 10 21 lba/min. The connection size and locations are shown in the chiller's submittals. Refer to local codes for relief valve vent line sizing information.

**Caution:** To prevent capacity reduction and relief valve damage, do not exceed vent piping code specifications.

**WARNING:** To prevent injury due to inhalation of R-22 gas, do not discharge refrigerant within the mechanical room or to the atmosphere.

The chilled water connections are on the left side of the unit (when facing the control panel). If it is necessary for the chilled water piping to enter the unit from the right side, elbows can be used to route the piping 180° over the top of the evaporator, as shown in Figure 8.

A vent is provided on the top of the evaporator at the leaving water end. Be sure to provide additional vents at high points in the piping to bleed air from the chilled water system. Install necessary pressure gauges to monitor the entering and leaving chilled water pressures.

**Caution:** To prevent damage to chilled water components, do not allow evaporator pressure (maximum working pressure) to exceed 215 psig.

Provide shutoff valves in lines to the gauges to isolate them from the system when they are not in use. Use rubber vibration eliminators to prevent vibration transmission through the water lines.

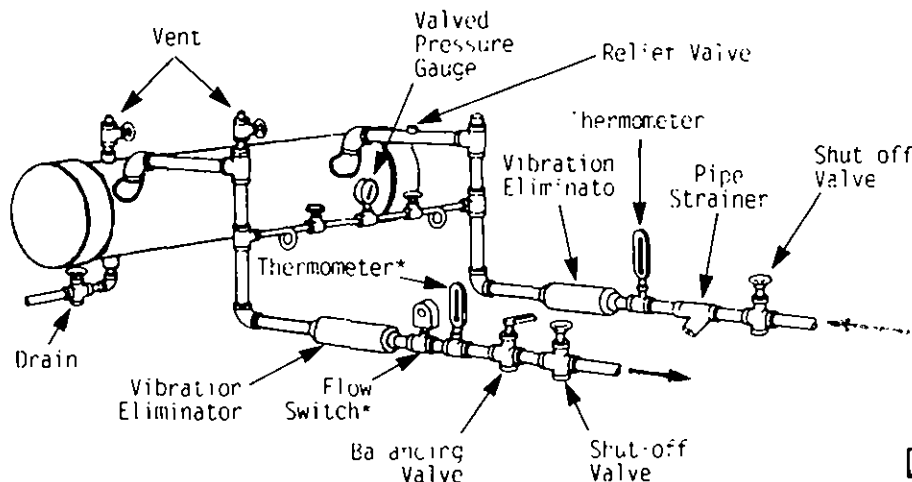
If desired, install thermometers in the lines to monitor entering and leaving water temperatures. Install a balancing valve in the leaving water line to control water flow balance. Install shutoff valves on both the entering and leaving water lines so that the evaporator can be isolated for service.

### Evaporator Piping

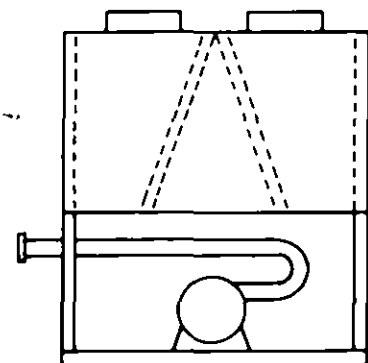
Figure 8 illustrates typical evaporator piping components. Components and layout will vary slightly, depending on the location of connections and the water source.

**Caution:** The chilled water connections to the evaporator are to be "victaulic" type connections. Do not attempt to weld these connections, as the heat generated from welding can cause internal damage to the evaporator.

**Figure 8**  
Suggested Piping for Typical RTAA Evaporator



\*User Option



Opposite-side connections  
(View from end opposite control panel)

## Evaporator Piping Components

"Piping components" include all devices and controls used to provide proper water system operation and unit safety. These components and their general locations are given below.

### Entering Chilled Water Piping

- Air vents (to bleed air from system).
- Water pressure gauges with shutoff valves.
- Vibration eliminators.
- Shutoff (isolation) valves.
- Thermometers (if desired).
- Cleanout tees.
- Relief valve.
- Pipe strainer

**Caution: To prevent tube damage install strainer in evaporator water inlet piping.**

### Leaving Chilled Water Piping

- Air vents (to bleed air from system).
- Water pressure gauges with shutoff valves
- Vibration eliminators.
- Shutoff (isolation) valves
- Thermometers.
- Cleanout tees.
- Balancing valve.
- Flow Switch (If desired).

**Caution: To prevent evaporator damage, do not exceed 215 psig (14.6 bar) evaporator water pressure.**

## Evaporator Drain

A 3/4" drain connection is located under the outlet end of the evaporator. This may be connected to a suitable drain to permit evaporator drainage during unit servicing. A shutoff valve must be installed on the drain line.

## Chilled Water Flow Switch

Chilled water flow protection is provided by the UCM without the need for a chilled water flow switch. A flow switch for chilled water is strictly discretionary but if not installed, a signal must be sent to the chiller to indicate that water flow has been established, eg. chilled water pump motor starter auxiliary contacts, building automation system, etc.

If additional chilled water flow protection is desired, use a field-installed flow switch or differential pressure switch with the pump motor starter auxiliary contacts to sense system water flow. Install and wire the flow switch in series with the chilled water pump motor starter auxiliaries (refer to "Interlock Wiring").

Specific connection and schematic wiring diagrams are shipped with the unit. Some piping and control schemes, particularly those using a single water pump for both chilled and hot water, must be analyzed to determine how and or if a flow sensing device will provide desired operation.

Follow the manufacturer's recommendations for selection and installation procedures. General guidelines for flow switch installation are outlined below.

**1.** Mount the switch upright, with a minimum of 5 pipe diameters of straight horizontal run on each side. Do not install close to elbows, orifices or valves.

**Note:** The arrow on the switch must point in the direction of flow.

**2.** To prevent switch fluttering, remove all air from the water system

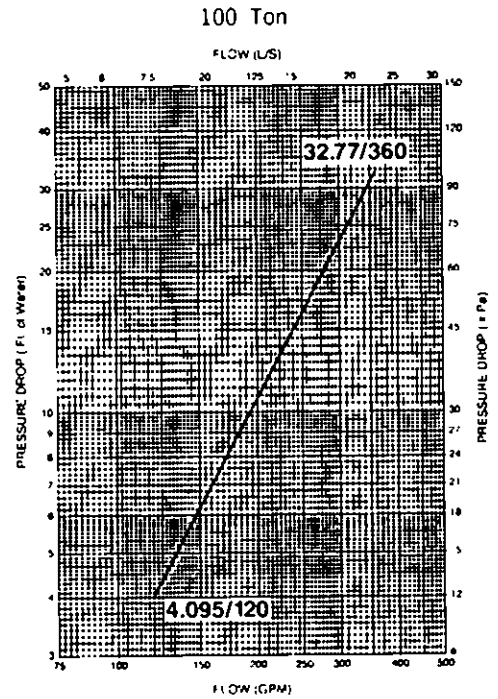
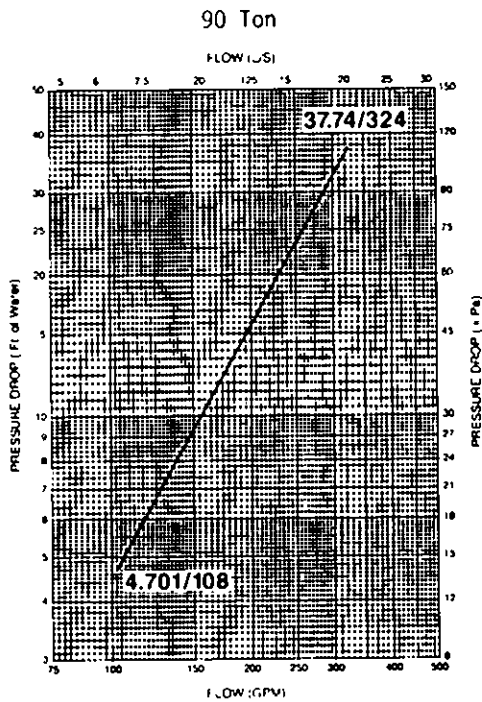
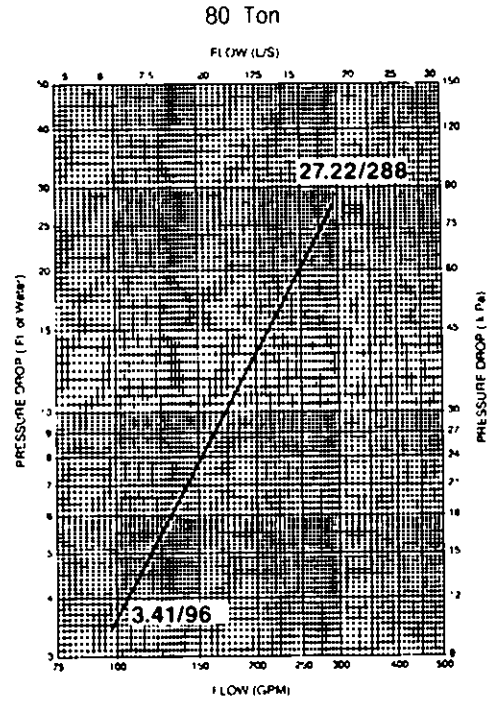
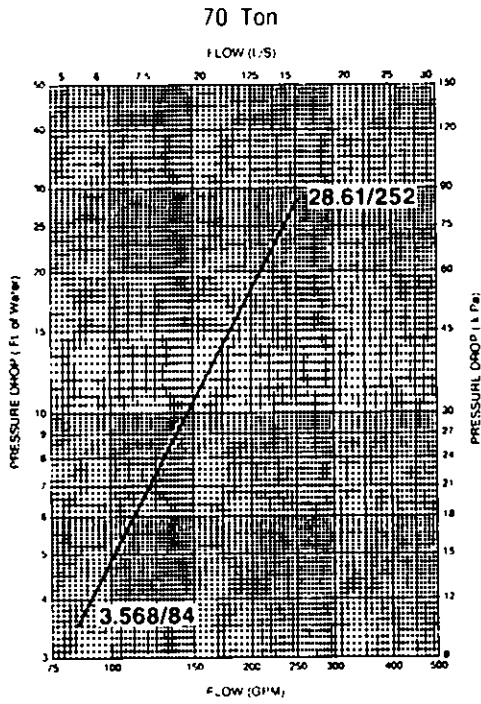
**Note:** The UCM provides a 6-second time delay after a "loss-of flow" diagnostic before shutting the unit down. Contact a qualified service representative if nuisance machine shutdowns persist.

**3.** Adjust the switch to open when water flow falls below nominal. Evaporator data is shown in Figure 9. Refer to Table 1 for minimum flow recommendations. Flow switch contacts are closed on proof of water flow.

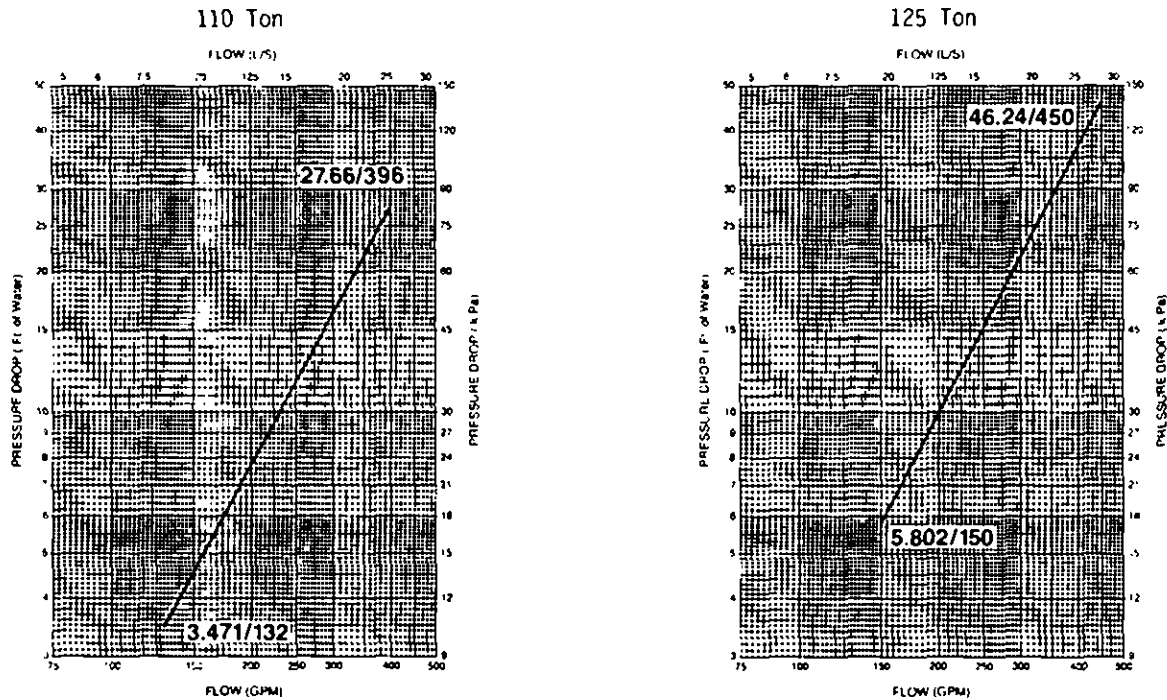
**4.** Install a pipe strainer in the entering evaporator water line to protect components from water-borne debris.

**Figure 9  
RTAA Evaporator  
Water Pressure Drop**

(Continued on next page)



**Figure 9**  
**RTAA Evaporator Water Pressure Drop**  
 (Continued from previous page)



**Water Treatment**

Using untreated or improperly treated water in these units may result in inefficient operation and possible tube damage. Consult a qualified water treatment specialist to determine whether treatment is needed. The following disclamatory label is provided on each RTAA unit:

**Customer Note**

The use of improperly treated or untreated water in this equipment may result in scaling, erosion, corrosion, algae or slime. The services of a qualified water treatment specialist should be engaged to determine what treatment, if any, is advisable. The Trane Company warranty specifically excludes liability for corrosion, erosion or deterioration of Trane equipment. Trane assumes no responsibilities for the results of the use of untreated or improperly treated water, or saline or brackish water.

**Caution: Do not use untreated or improperly treated water. Equipment damage may occur.**

**Water Pressure Gauges**

Install field-supplied pressure gauges (with manifolds, whenever practical) as shown in Figure 8. Locate pressure gauges or taps in a straight run of pipe, avoid placement near elbows, etc. Be sure to install the gauges at the same elevation.

To read manifolded pressure gauges, open one valve and close the other (depending upon the reading desired). This eliminates errors resulting from differently calibrated gauges installed at unmatched elevations.

**Water Pressure Relief Valves**

Install a water pressure relief valve in the evaporator inlet piping between the evaporator and the inlet shutoff valve, as shown in Figure 8. Water vessels with close-coupled shutoff valves have a high potential for hydrostatic pressure buildup on a water temperature increase. Refer to applicable codes for relief valve installation guidelines.

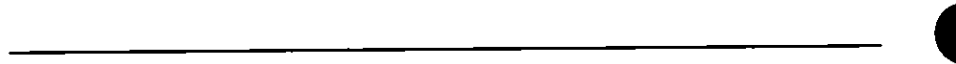
**Caution: To prevent shell damage, install pressure relief valves in the evaporator water system.**

**Freeze Protection**

If the unit will remain operational at sub-freezing ambient temperatures the chilled water system must be protected from freezing, following the steps listed below:

1. Heat tape is factory-installed on the packaged unit evaporator and will protect it from freezing in ambient temperatures down to -20 F.
2. Install heat tape on all water piping, pumps, and other components that may be damaged if exposed to freezing temperatures. Heat tape must be designed for low ambient temperature applications. Heat tape selection should be based on the lowest expected ambient temperature.
3. Add a non-freezing, low temperature, corrosion inhibiting, heat transfer fluid to the chilled water system. The solution must be strong enough to provide protection against ice formation at the lowest anticipated ambient temperature. Refer to Table 1 for evaporator water storage capacities.

**Note:** Use of glycol type antifreeze reduces the cooling capacity of the unit and must be considered in the design of the system specifications.



# Installation – Mechanical

## Remote Evaporator Interconnecting Refrigerant Piping

---

### General

The RTAA outdoor unit with the Remote Evaporator option is shipped as two pieces: the outdoor unit (condensing) and the evaporator. Short suction line connections are provided with the outdoor condensing unit. The liquid line connections are at the end opposite the control panel.

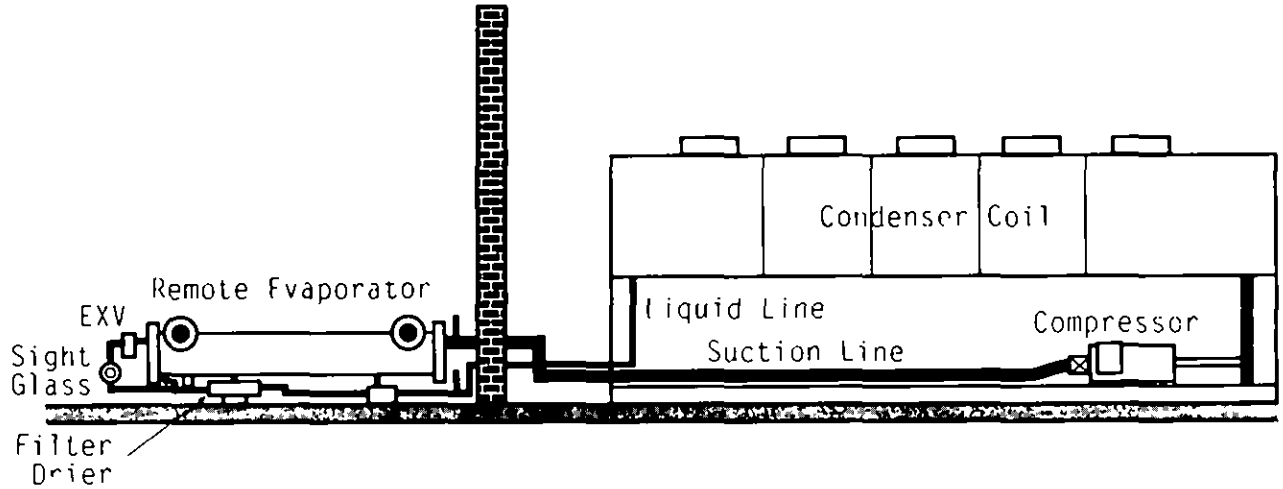
The remote evaporator is shipped complete, with factory-mounted refrigeration specialties (electronic expansion valves, sight-glasses and removable core filter-dryers). All evaporator refrigerant line connections are at one end of the evaporator. The installing contractor need only provide and install the interconnecting refrigerant piping between the remote evaporator and the outdoor condensing unit. In some instances, the installing contractor may also need to lengthen the factory installed suction accumulator.

### System Configuration and Interconnecting Refrigerant Piping

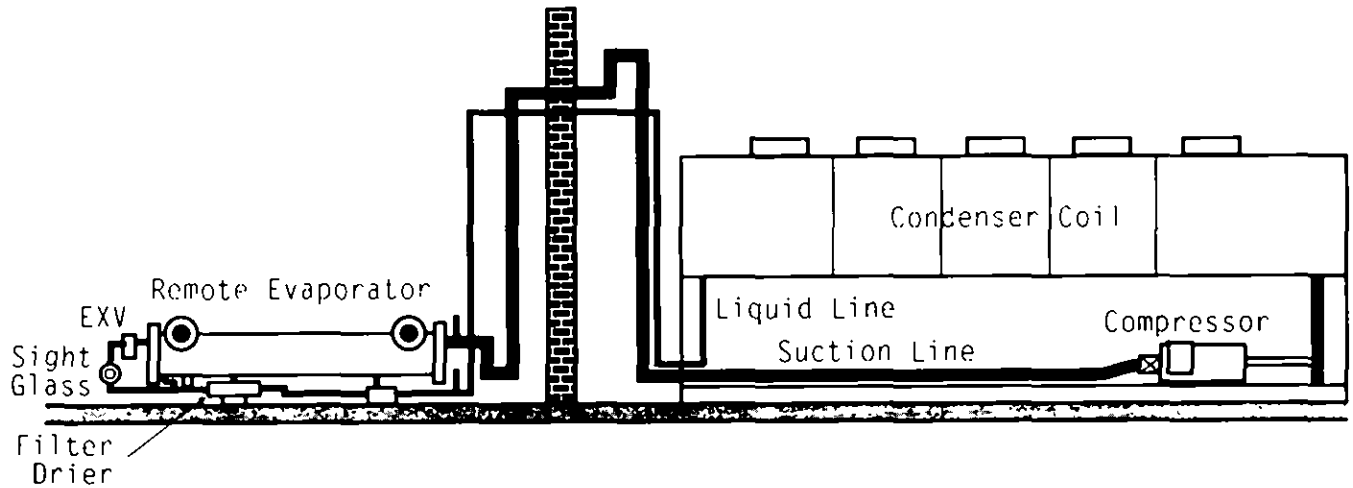
The system may be configured in any of the four arrangements shown in Figures 9a through 9d. The configurations and their associated elevations, along with the total distance between the remote evaporator and the compressor/condenser section, play a critical role in determining suction and liquid line sizes. This will also affect field refrigerant and oil charges. Consequently, there are physical limits which must not be violated if the system is to operate as designed. Please note the following requirements for field installation:



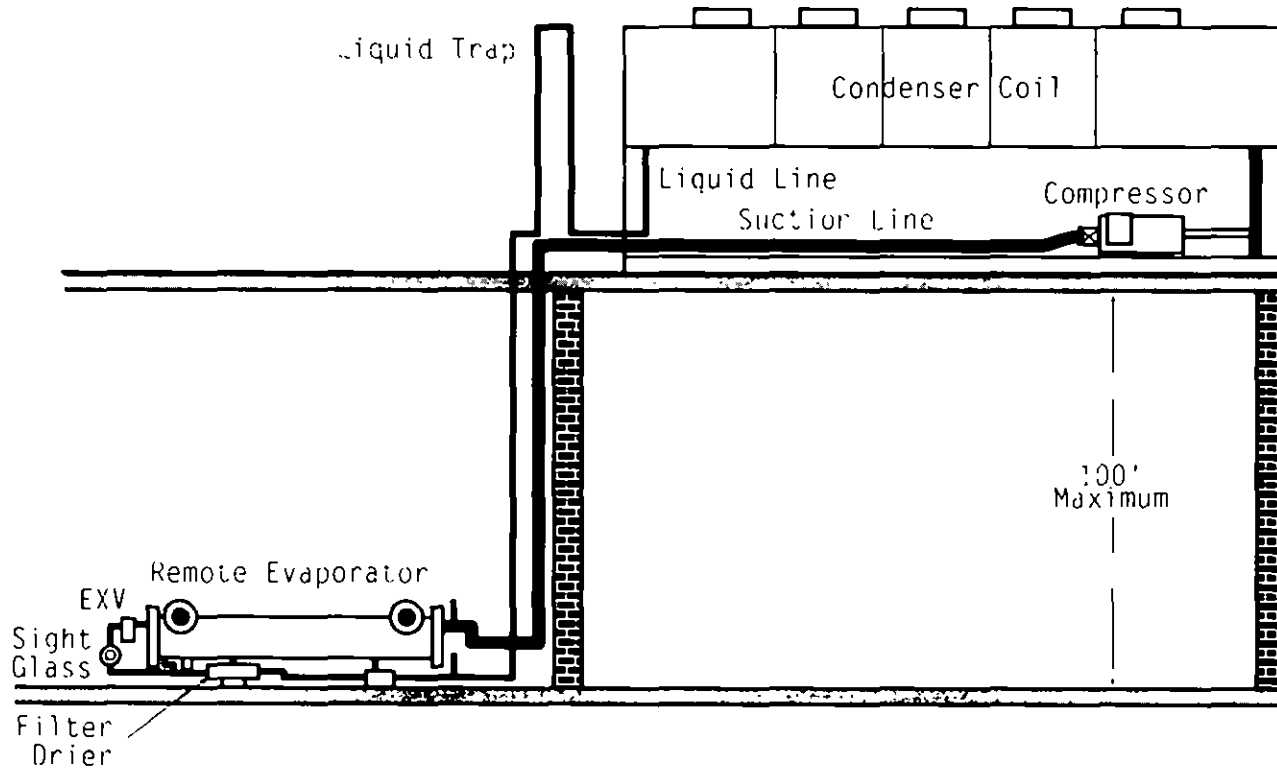
**Figure 9a**  
**Remote Evaporator Installation**  
**No Elevation Difference, Suction and Liquid Lines 20 Inches or Less**



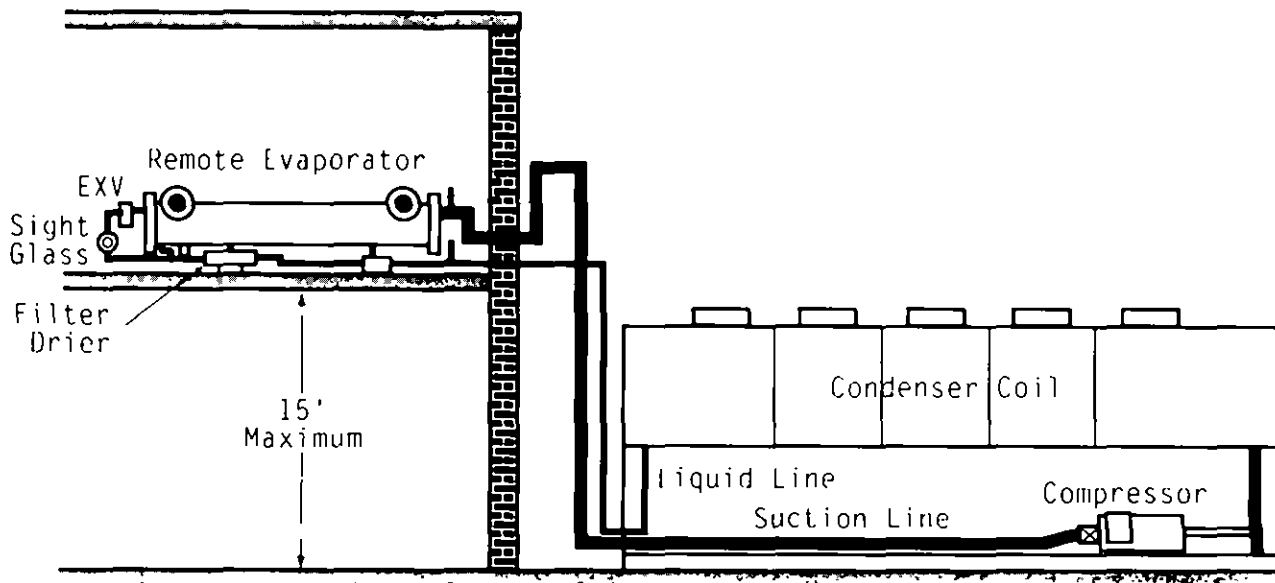
**Figure 9b**  
**Remote Evaporator Installation**  
**No Elevation Difference, Suction and Liquid Lines 15 Feet or Less**  
**(Suction accumulations may be required)**



**Figure 9c**  
**Remote Evaporator Installation**  
**Condensing Unit Above Evaporator – 100 Feet or Less**



**Figure 9d**  
**Remote Evaporator Installation**  
**Condensing Unit Below Evaporator – 15 Feet or Less**  
**(Suction accumulator may be required)**



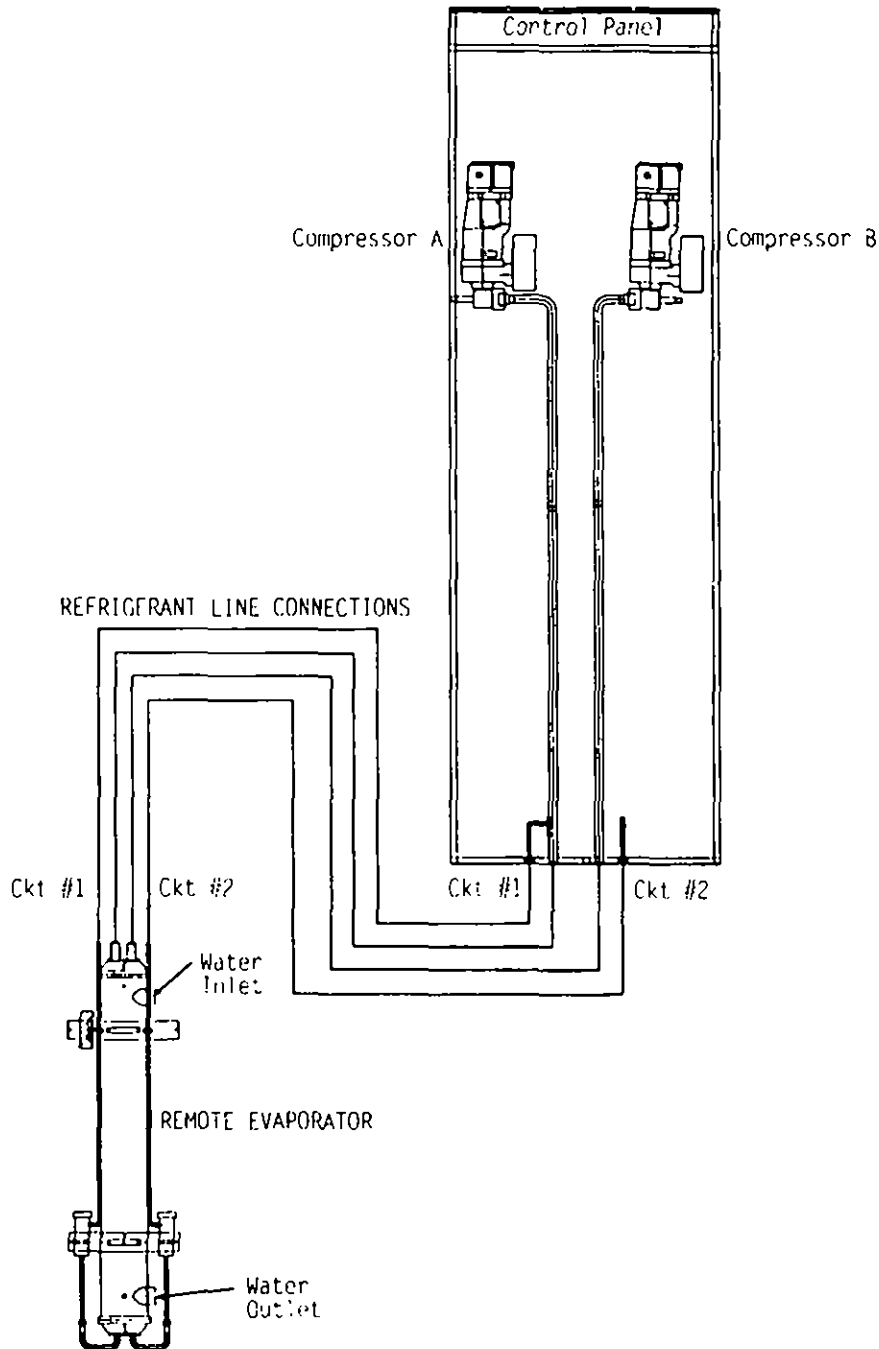
1. The remote evaporator MUST be matched with its respective outdoor condensing unit.

2. The circuit number on the outdoor condensing unit must match the circuit number on the evaporator, i.e. circuit #1 on the outdoor condensing unit must be connected with circuit #1 on the remote evaporator and likewise for circuit #2

See Figure 9e for circuit number identification. RTAA Circuit Capacities are shown in Table 2a.

**Caution: If the circuits are crossed, serious equipment damage may occur.**

**Figure 9e**  
**Refrigerant Circuit Identification**



**Table 2a  
RTAA Circuit Capacities  
(nominal tons)**

Model	Circuit 1	Circuit 2
70	35	35
80	40	40
90	50	40
100	50	50
110	60	50
125	60	60

3. Piping between the evaporator and outdoor unit is not to exceed 200 actual feet and/or an equivalent length of 300 feet. (The latter includes the equivalent length of pressure drops of all associated field installed fittings, valves, accessories, and straight lengths of interconnecting piping including the suction accumulator )

4. Horizontal portions of suction lines must be downward sloping toward the compressor at least 1/2 inch for each 10 feet of run. This promotes the movement of oil in the direction of gas flow

5. Suction lines must be insulated.

6. The line sizes defined in Tables 2c, 2d, and 2e are to be used only for 40-50 F leaving water temperature and/or full-load ice-making applications.

**Note:** The factory must size piping for leaving water temperatures other than 40-50 F.

**Table 2b  
Equivalent Lengths of Non-Ferrous Valves and Fittings (feet)**

Line Size Inches OD	Globe Valve	Short Angle Valve	Short Radius ELL	Long Radius ELL
1 1/8	87	29	2.7	1.9
1-3/8	102	33	3.2	2.2
1-5/8	115	34	3.8	2.6
2 1/8	141	39	5.2	3.4
2-5/8	159	44	6.5	4.2
3-1/8	185	53	8	5.1

Reproduced by permission of Air Conditioning and Refrigeration Institute

**Table 2c  
Liquid Line Sizes**

Total Equiv. Length (ft)	35 Ton Circuit			
	Liquid Line Size (OD")			
	Horizontal or Downflow	Upflow 1-5 ft	Upflow 6-10 ft	Upflow 11-15 ft
25	1.125	1.125	1.125	1.125
50	1.125	1.125	1.125	1.125
75	1.125	1.125	1.125	1.375
100	1.125	1.125	1.125	1.375
125	1.125	1.125	1.125	1.375
150	1.125	1.125	1.125	1.375
175	1.125	1.125	1.375	1.375
200	1.125	1.125	1.375	1.375
225	1.125	1.125	1.375	1.625
250	1.125	1.375	1.375	1.625
275	1.125	1.375	1.375	1.625
300	1.375	1.375	1.375	1.625

Total Equiv. Length (ft)	50 Ton Circuit			
	Liquid Line Size (OD")			
	Horizontal or Downflow	Upflow 1-5 ft	Upflow 6-10 ft	Upflow 11-15 ft
25	1.125	1.125	1.125	1.125
50	1.125	1.125	1.125	1.375
75	1.125	1.125	1.375	1.375
100	1.125	1.125	1.375	1.375
125	1.125	1.375	1.375	1.625
150	1.125	1.375	1.375	1.625
175	1.375	1.375	1.375	1.625
200	1.375	1.375	1.375	1.625
225	1.375	1.375	1.625	1.625
250	1.375	1.375	1.625	2.125
275	1.375	1.375	1.625	2.125
300	1.375	1.375	1.625	2.125

Total Equiv. Length (ft)	40 Ton Circuit			
	Liquid Line Size (OD")			
	Horizontal or Downflow	Upflow 1-5 ft	Upflow 6-10 ft	Upflow 11-15 ft
25	1.125	1.125	1.125	1.125
50	1.125	1.125	1.125	1.375
75	1.125	1.125	1.125	1.375
100	1.125	1.125	1.125	1.375
125	1.125	1.125	1.375	1.375
150	1.125	1.125	1.375	1.375
175	1.125	1.375	1.375	1.625
200	1.125	1.375	1.375	1.625
225	1.375	1.375	1.375	1.625
250	1.375	1.375	1.375	1.625
275	1.375	1.375	1.375	1.625
300	1.375	1.375	1.375	1.625

Total Equiv. Length (ft)	60 Ton Circuit			
	Liquid Line Size (OD")			
	Horizontal or Downflow	Upflow 1-5 ft	Upflow 6-10 ft	Upflow 11-15 ft
25	1.125	1.125	1.125	1.375
50	1.125	1.125	1.375	1.375
75	1.125	1.125	1.375	1.625
100	1.125	1.375	1.375	1.625
125	1.375	1.375	1.375	1.625
150	1.375	1.375	1.375	1.625
175	1.375	1.375	1.625	1.625
200	1.375	1.375	1.625	2.125
225	1.375	1.375	1.625	2.125
250	1.375	1.625	1.625	2.125
275	1.375	1.625	1.625	2.125
300	1.375	1.625	1.625	2.125

**Table 2d  
Suction Line Sizes ("O.D.")  
for Upflow Lines**

Circuit Size (nominal tons)	Outside Diameter (inches)
35	2 1/8
40	2-1/8
50	2 5/8
60	2-5/8

**Table 2e  
Suction Line Sizes ("O.D.") for  
Horizontal and/or Downflow Lines**

Total Equiv. Length (ft)	Circuit Size:			
	35 Ton	40 Ton	50 Ton	60 Ton
25	2.125	2.125	2.625	2.625
50	2.125	2.125	2.625	2.625
75	2.125	2.125	2.625	2.625
100	2.125	2.625	2.625	2.625
125	2.125	2.625	2.625	2.625
150	2.625	2.625	2.625	3.125
175	2.625	2.625	2.625	3.125
200	2.625	2.625	2.625	3.125
225	2.625	2.625	2.625	3.125
250	2.625	2.625	3.125	3.125
275	2.625	2.625	3.125	3.125

7. Figure 9a depicts an installation where the remote evaporator elevation is the same as that of the outdoor condensing unit. The suction and liquid line are horizontal or down flowing only.

8. Figure 9b shows a variation to Figure 9a. The remote evaporator and outdoor condensing unit are at the same elevation but interconnecting piping may be installed up to 15 feet above the base elevation. In this case a suction line trap is required to assure oil return, and the suction accumulator line must be extended at least by the amount determined from Table 2f.

9. For installations where the remote evaporator is at a lower elevation than the outdoor condensing unit as shown in Figure 9c, the elevation difference is not to exceed 100 feet. An inverted liquid line trap to prevent unwanted free cooling modes and a suction line trap to assure oil return from the evaporator must be included on both circuits as shown. The apex of the liquid line trap should be at a height above the condenser coils. The highest point of the suction line piping must not exceed 4 inches above the outdoor condensing unit suction line connection point.

10. When the elevation of the remote evaporator exceeds that of the outdoor condensing unit as shown in Figure 9d, the elevation difference may not exceed 15 feet. The suction accumulator line must be extended at least by the amount determined from Table 2f. This line must not exceed 4 inches above the outdoor unit suction line connection point. An inverted suction line trap whose apex is 3

to 15 feet above the elevation of the remote evaporator is required in both circuits.

11. Compressor & oil separator heaters must be on at least 24 hours prior to compressor start.

## Line Sizing

To determine the appropriate outside diameter for field installed liquid and suction lines, it is first necessary to establish the equivalent length of pipe for each line. It is also necessary to know the capacity (tons) of each circuit. Circuit capacities for each RTAA unit are listed in Table 2a.

### Liquid Line Sizing Steps

Line sizing is an iterative process. While iterating to determine the proper equivalent line length use the "Horizontal or Downflow" column of Table 2c. After the final equivalent line length has been determined in step # 9, then break down the piping into it's "Horizontal or "Downflow" and "Upflow" components and select the proper outside diameter. Note that "Upflow" has a column for one to five, six to ten and eleven to fifteen feet.

The steps to compute liquid line size are as follows:

1. Compute the actual length of field installed piping
2. Multiply the length from step # 1 by 1.5 to estimate the equivalent length.
3. Using Table 2c for the proper tonnage circuit, look in the "Horizontal or Downflow" column. Find the outside diameter that corresponds to the equivalent length computed in step # 2.
4. With the outside diameter found in step # 3, use Table 2b to determine the equivalent lengths of each fitting in the field installed piping.
5. Sum the equivalent lengths of all the field installed elbows.
6. Add the length found in step # 5 to the actual length from step # 1. This is your new equivalent line length.
7. Using Table 2c again, find the new outside diameter that corresponds to the new equivalent line length from step # 6.
8. Using Table 2b and the new outside diameter found in step # 7, find the equivalent line length of each elbow, and sum them.
9. Add the length found in step # 8 to the actual length from step # 1. This is your final equivalent line length.
10. With the final equivalent line length found in step # 9, use Table 2c to select the proper outside diameter for horizontal or downflow lines, and any upflow lines.

**Table 2f**  
**Additional Suction Accumulator Line**

Liquid Line Length in Actual Ft.	Required Length in Feet of Field Installed Suction Line Accumulator							
	35 Ton Circuit		40 Ton Circuit		50 Ton Circuit		60 Ton Circuit	
	2 1/8" O.D. Suction Line	2 5/8" O.D. Suction Line	2 1/8" O.D. Suction Line	2 5/8" O.D. Suction Line	2 5/8" O.D. Suction Line	3 1/8" O.D. Suction Line	2 5/8" O.D. Suction Line	3 1/8" O.D. Suction Line
20	1	1	5	3	9	6	14	10
40	7	5	14	9	15	11	21	15
60	14	9	23	15	21	15	27	19
80	20	13	32	21	28	19	33	23
100	26	17	N/A	26	34	24	40	28
120	32	21	N/A	32	40	28	46	32
140	N/A	25	N/A	38	46	33	52	37
160	N/A	29	N/A	43	53	37	N/A	41
180	N/A	33	N/A	49	59	41	N/A	45
200	N/A	37	N/A	55	65	46	N/A	50

### Example Liquid Line Sizing

For this example, refer to Tables 2a, 2b, 2c, and Figure 9f, and assume a 50 ton circuit

1. From Figure 9f, the actual length of field installed piping is:  
 $80 + 8 + 8 + 21 = 117$  feet
2. Estimate equivalent line length:  
 $117 \text{ feet} \times 1.5 = 175.5$  feet
3. From Table 2c for a 50 ton circuit, for 175 equivalent feet the OD is 1-3/8 inches
4. In Figure 9f there are six long-radius elbows. From Table 2b, for 1-3/8 inch elbows, the equivalent feet is:  
 $6 \text{ elbows} \times 2.2 \text{ feet} = 13.2$  feet
5. Adding equivalent feet from step #4 to step #1 gives  
 $13.2 \text{ feet} + 117 \text{ feet} = 130.2$  feet
6. From Table 2c, for a 50 ton circuit, for 125 equivalent feet (nearest to 130.2), the OD is 1-1/8 inches
7. From Table 2b, for 1-1/8" OD long-radius elbows, the equivalent feet is  
 $6 \text{ elbows} \times 1.9 \text{ feet} = 11.4$  feet
8. Adding equivalent feet from step #7 to step #1 gives.  
 $11.4 \text{ feet} + 117 \text{ feet} = 128.4$  feet
9. From Table 2c, for a 50 ton circuit, for 125 equivalent feet (also nearest to 128.4 feet), the OD is still:  
 Horizontal or Downflow = 1 1/8 inches

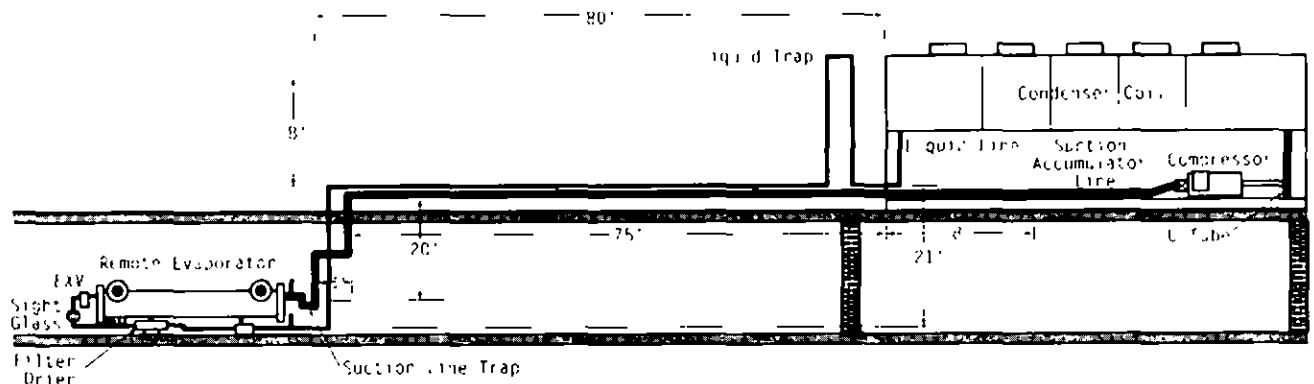
10. From Figure 9f, there is 8 feet of upflow on the liquid line inverted trap. Therefore, select:  
 Upflow = 1-3/8 inches

### Suction Line Sizing Steps

The steps to compute suction line size are as follows:

1. Break the suction line into its "Upflow" and "Horizontal or Downflow" components. The horizontal or downflow length should include that portion of field-installed suction line within the condensing unit's base. See Figure 9f.
  2. From Table 2d, select the appropriate "Upflow" suction line outside diameter according to the circuit tonnage. This is the diameter of the upflow suction line and any fittings in the upflow line.
  3. With the diameter found in step #2, use Table 2b to find the equivalent length of each fitting in the upflow line. Sum the equivalent lengths of all the fittings in the upflow line.
  4. Sum the final length found in step #3 with the actual length of the upflow line. This is the final equivalent length of the upflow portion of the suction line.
  5. Multiply by 1.5, the actual length of the horizontal or downflow portion of the suction line.
  6. Add the length from step #5 to the length from step #4. This is the first estimate of the equivalent line length
  7. In Table 2e find the column for the circuit tonnage you are sizing. In that column find the outside diameter that corresponds to the equivalent length computed in step #6.
  8. Use Table 2b and the diameter found in step #7 to determine the equivalent lengths of each fitting.
  9. Sum the following: equivalent lengths of the fittings from step #8, the actual length of the horizontal or downflow suction line, and the equivalent length of the upflow line found in step #4. This is the new estimate of the equivalent length of the entire suction line
  10. With the new length found in step #9, go back to Table 2e and find the new diameter for the circuit you are sizing.
  11. Repeat steps #8-10 with the new diameter found in step #10.
  12. The diameter found in step #11 is the horizontal or downflow suction line diameter.
  13. The diameter found in step #2 is the diameter of the upflow suction line and any fittings in the upflow line.
- Note:** The diameters of the upflow, and horizontal or downflow portions of the suction line may differ depending on the application.

Figure 9f  
Liquid Line Sizing Example



### Example Suction Line Sizing

For this example, refer to Tables 2b, 2d, 2e, and Figure 9f, and assume a 50 ton circuit on a 100 ton chiller.

- From Figure 9f, the actual length of upflow, and horizontal or downflow is:  
 upflow  $(20 + 5) = 25$  feet  
 horizontal or downflow  $(75+8) = 83$  ft
- Table 2d for a 50 ton circuit shows  
 Upflow suction line outside diameter = 2-5/8 inches
- According to Figure 9f, there are 6 long radius ELL's. From Table 2b for a diameter of 2-5/8 inches:  
 6 elbows x 3.4 feet = 20.4 feet
- Final equivalent length of upflow suction line.  
 $20.4 + 25 = 45.4$  feet
- There are no fittings in the horizontal portion. Therefore, the final equivalent line length is:  
 $45.4 + 83 = 128.4$  feet
- From Table 2e, for a 50 ton circuit, and 125 equivalent feet (nearest to 128.4):  
 Horizontal or downflow suction line diameter = 2-5/8 inches

**Note:** In this example, the horizontal line is pitched downward in the direction of flow.

### Suction Accumulator Sizing

Installations similar to those in Figures 9b and 9d will require that the suction accumulator be extended at least by the amount shown in Table 2f. The suction accumulator length in feet is dependent upon: circuit tonnage, suction line O.D., and actual liquid line length.

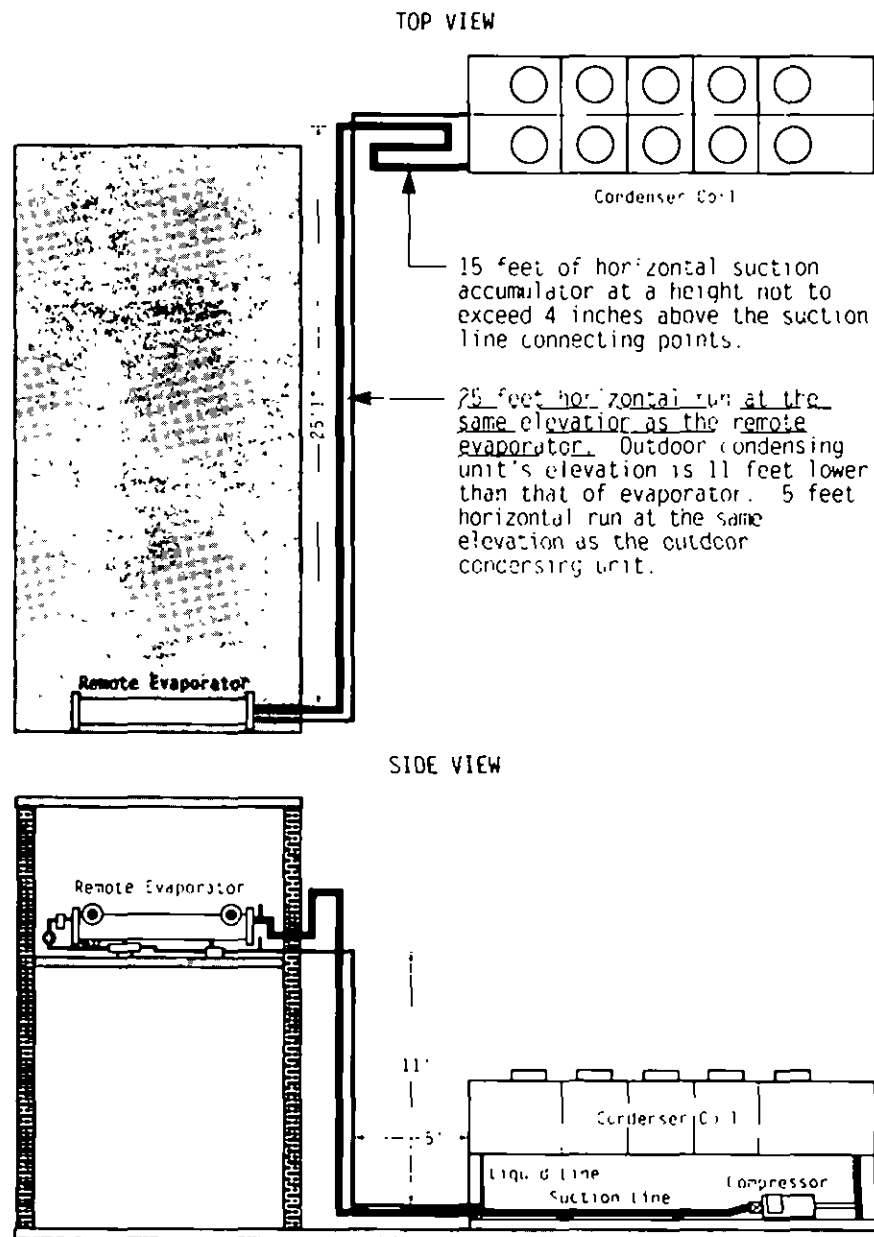
The following example uses Figure 9g and assumes a 50 ton circuit with a 2-5/8 inch O.D. suction line. Figure 9g illustrates an installation where the remote evaporator is 11 feet above the outdoor condensing unit. A liquid line at the same elevation as the evaporator runs horizontally 25 feet. Then it drops 11 feet to the same elevation as the suction line connecting points on the outdoor condensing unit, and runs horizontally 5 feet to the outdoor condensing unit. From Figure 9g, the actual length of liquid line is 41 feet  $(25 + 11 + 5)$ . With the previously mentioned assumptions, Table 2f indicates 15 feet of 2-5/8 inch O.D. suction accumulator needs to be added. Figure 9g shows one method of piping the additional 15 feet.

**Note:** In this example, if the liquid and suction lines had dropped the 11 feet from the evaporator and then run the 25 feet horizontal at the outdoor condensing unit's elevation, the 15 feet of suction accumulator would not be required.

**Note:** When sizing suction line diameters, the length of the suction accumulator should be included in any computations.

The height of the suction accumulator, specified in Table 2f, may not exceed 4 inches above the suction line connecting point at the outdoor condensing unit. In addition, the suction accumulator must be pitched toward the compressor 1/2 inch per 10 feet of horizontal run.

**Figure 9g**  
Suction Accumulator Sizing Example





---

## Piping Installation Procedures

The outdoor unit and the evaporator are shipped with a 25 psig holding pressure of dry nitrogen. Do not relieve this pressure until field installation of the refrigerant piping is to be accomplished. This will require the removal of the temporary pipe caps.

**Note:** Use Type L refrigerant-grade copper tubing only.

The refrigerant lines must be isolated to prevent line vibration from being transferred to the building. Do not secure the lines rigidly to the building at any point.

All horizontal suction lines should be pitched downward, in the direction of flow, at a slope of 1/2 in. per 10 feet of run. This allows for larger line size, which will improve unit efficiency.

Do not use a saw to remove end caps, as this may allow copper chips to contaminate the system. Use a tubing cutter or heat to remove the end caps.

When sweating copper joints, flow dry nitrogen through the system. This prevents scale formation and the possible formation of an explosive mixture of R-22 and air. This will also prevent the formation of toxic phosgene gas, which occurs when refrigerant is exposed to open flame.

---

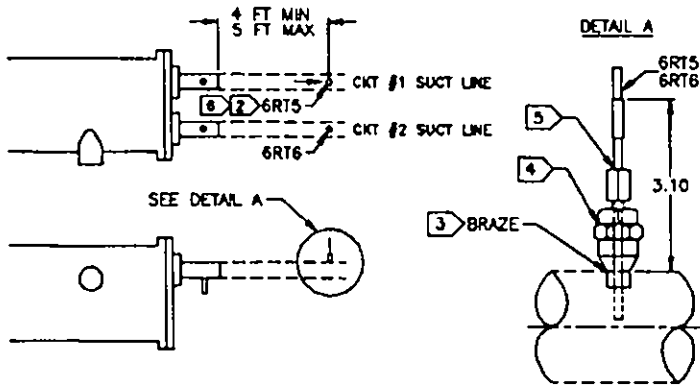
**WARNING:** To prevent injury or death, due to explosion and/or inhalation of phosgene gas, purge the system thoroughly while sweating connections. Use a pressure regulator in the line between the unit and the high pressure nitrogen cylinder to avoid over-pressurization and possible explosion.

---

## Refrigerant Sensors

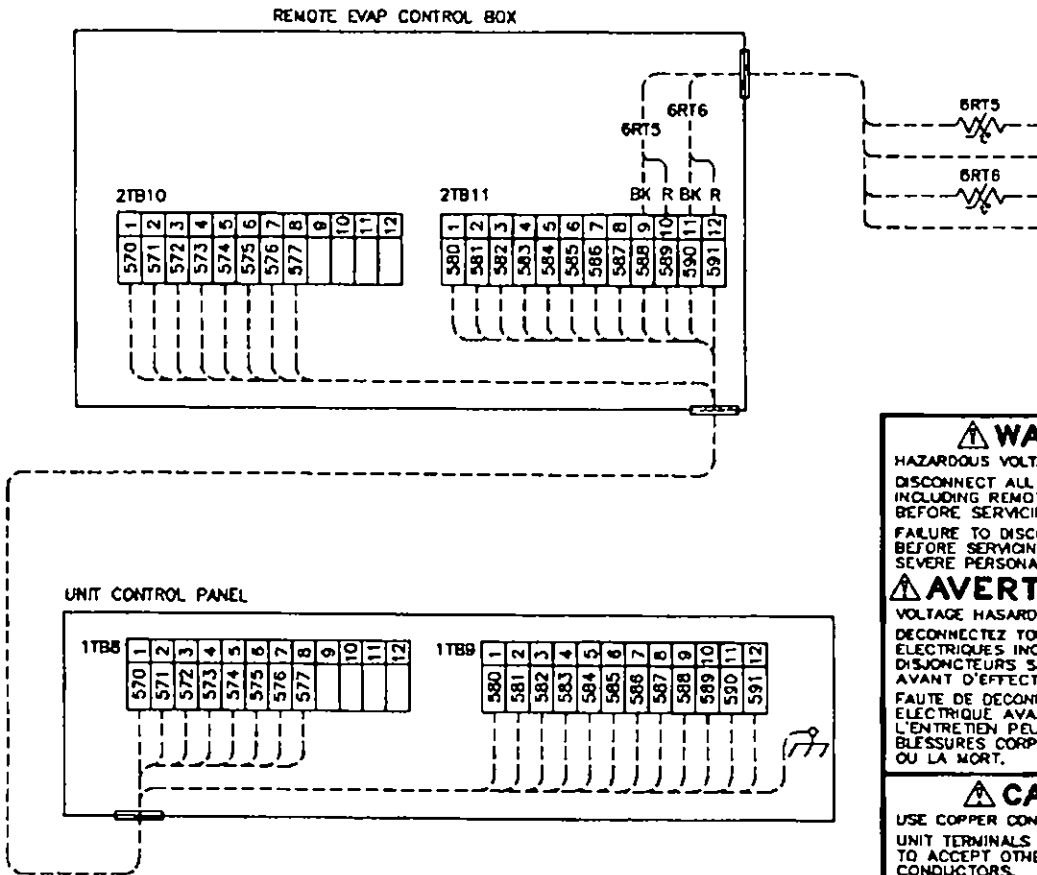
The suction line refrigerant sensors must be installed by the contractor installing the refrigerant piping. The sensors are pre-wired and each is "wire-tied" to its respective liquid line. Fittings and adapters for mounting of the sensors are located in the remote evaporator terminal box. See Figure 9h for mounting instructions.

**Figure 9h**  
**Refrigerant Sensor Mounting and Wiring**



**NOTES:**

1. ALL CUSTOMER CONTROL WIRING MUST HAVE A MINIMUM RATING FOR 150 VOLTS.
2. DRILL .469 DIA HOLE IN TOP OF CIRCUITS #1 & 2 SUCTION LINE. REMOVE ALL CHIPS & DIRT FROM INSIDE TUBING BEFORE BRAZING ADAPTER IN LINES.
3. BRAZE ADAPTERS IN TOP OF SUCTION LINES BEFORE INSTALLING SENSORS & FITTINGS. USE AWS BRAZING FLUX TYPE JA OR JB & BCUP ALLOY.
4. APPLY TEFLON TAPE TO FITTING THREADS BEFORE TIGHTENING.
5. TIGHTEN NUT UNTIL SENSOR WILL NOT TURN BY HAND, THEN TIGHTEN 1-1/4 TURNS. DO NOT OVER TIGHTEN.
6. ORIENTATE SENSOR WITH SINGLE HOLE SIDE FACING FLOW, INDICATED BY ARROW.



**⚠ WARNING**

HAZARDOUS VOLTAGE!  
 DISCONNECT ALL ELECTRIC POWER INCLUDING REMOTE DISCONNECTS BEFORE SERVICING.  
 FAILURE TO DISCONNECT POWER BEFORE SERVICING CAN CAUSE SEVERE PERSONAL INJURY OR DEATH.

**⚠ AVERTISSEMENT**

VOLTAGE HASARDEUX!  
 DECONNECTEZ TOUTES LES SOURCES ELECTRIQUES INCLUANT LES DISJONCTEURS SITUES A DISTANCE AVANT D'EFFECTUER L'ENTRETIEN.  
 FAUTE DE DECONNECTER LA SOURCE ELECTRIQUE AVANT D'EFFECTUER L'ENTRETIEN PEUT ENTRAINDER DES BLESSURES CORPORELLES SEVERES OU LA MORT.

---

**⚠ CAUTION**

USE COPPER CONDUCTORS ONLY  
 UNIT TERMINALS ARE NOT DESIGNED TO ACCEPT OTHER TYPES OF CONDUCTORS.  
 FAILURE TO DO SO MAY CAUSE DAMAGE TO THE EQUIPMENT.

## Leak Test and Evacuation

After installation of the refrigerant piping, thoroughly test the system for leaks. Pressure test the system at pressures required by local codes

Immediately before evacuation, install the liquid line filter cores. These will be shipped with the evaporator.

**Note:** Do not install these before the circuit is ready for evacuation, as the cores will absorb moisture from the atmosphere.

For field evacuation, use a rotary-type vacuum pump capable of pulling a vacuum of 100 microns or less. Follow the pump manufacturer's instructions for proper use of the pump. The line used to connect the pump to the system should be copper and be the largest diameter that can be practically used. A larger line size with minimum flow resistance can significantly reduce evacuation time.

Use the ports on the compressor suction service valves and the liquid line shutoff valves for access to the system for evacuation. Insure that the compressor suction service valve, the liquid line shutoff valve, the oil line shutoff valve and any field installed valves are open in the proper position before evacuating.

Insulate the entire suction line and the suction accumulator line. Where the line is exposed to the weather, wrap it with weatherproof tape and seal with weatherproof compound.

**Table 2g  
System Refrigerant Charge**

Circuit Size	Lbs. of R-22
35	58
40	61
50	73
60	98

## Refrigerant and Additional Oil Charge

### Refrigerant Charge Determination

The approximate amount of refrigerant charge required by the system must be determined by referring to Table 2g and must be verified by running the system and checking the liquid line sightglasses.

To determine the appropriate charge, first refer to Table 2g to establish the required charge without the field-installed piping. Next, determine the charge required for the field-installed piping by referring to Table 2h.

**Note:** The amounts of refrigerant listed in Table 2h are based on 100 feet of pipe. Actual requirements will be in direct proportion to the actual length of piping.

**Note:** Table 2h assumes:  
Liquid Temperature = 100 F  
Suction Temperature = 35 F  
Suction Superheat Temperature = 4 F

### Example: Refrigerant Charge Computation

Determine the approximate amount of charge required for an RTAA 100 ton unit with a remote evaporator that is located 75 feet away (i.e. the actual length of field-installed pipe is 75 feet for each suction line and liquid line). Assume that the suction lines have been previously determined to be 2-5/8 in. O.D. and the liquid lines are 1-1/8 in. O.D.

- From Table 2g for a 50 ton circuit requires = 73 lbs. R-22.
- From Table 2h for a 2-5/8 inch OD suction line: 75 feet x 4.5 lbs./100 feet = 3.4 lbs. R-22
- From Table 2h for a 1 1/8 inch OD liquid line: 75 feet x 40.8 lbs./100 feet = 30.6 lbs. R-22
- Total R-22 charge per circuit: Sum results of steps #1,2, and 3 = 107 lbs R-22 per circuit
- Total R-22 charge per machine: 2 circuits x 107 lbs. R-22/circuit = 214 lbs. R-22 per machine

**Table 2h  
Field-Installed Piping Charge**

Pipe O.D. (inches)	Suction Line Lbs. R-22 per 100 ft.	Liquid Line Lbs. R-22 per 100 ft.
1-1/8	0.78	40.8
1-3/8	1.2	62.2
1-5/8	1.7	88
2-1/8	2.9	153.1
2-5/8	4.5	236.1
3-1/8	6.4	-

The approximate amount of refrigerant is therefore the sum of the values determined from Tables 2g and 2h.

### Oil Charge Determination

The unit is factory charged with the amount of oil required by the system, without the field-installed piping. The amount of additional oil required is dependent upon the amount of refrigerant that is added to the system for the field-installed piping.

Use the following formula to calculate the amount of oil to be added:

$$\text{Pints of Oil (Trane Oil-31)} = \frac{\text{lbs. of refrigerant added for field-installed piping}}{100}$$

From the example above, in which the weight of the additional refrigerant added for the field-installed piping was 34.0 lbs (30.6 + 3.4), the amount of oil to be added equals 0.34 pints (34.0/100) per circuit.

# Installation – Electrical

## General Recommendations

**WARNING: The Warning Label shown in Figure 10 is displayed on the equipment and shown on wiring diagrams and schematics. Strict adherence to these warnings must be observed.**

All wiring must comply with local codes and the National Electric Code. Typical field wiring diagrams are shown in Figure 11. Minimum circuit ampacities and other unit electrical data are on the unit nameplate and are shown in Table 3. See the unit order specifications for actual electrical data. Specific electrical schematics and connection diagrams are shipped with the unit.

**Caution: To avoid corrosion and overheating at terminal connections, use copper conductors only.**

Figure 10  
Warning Label

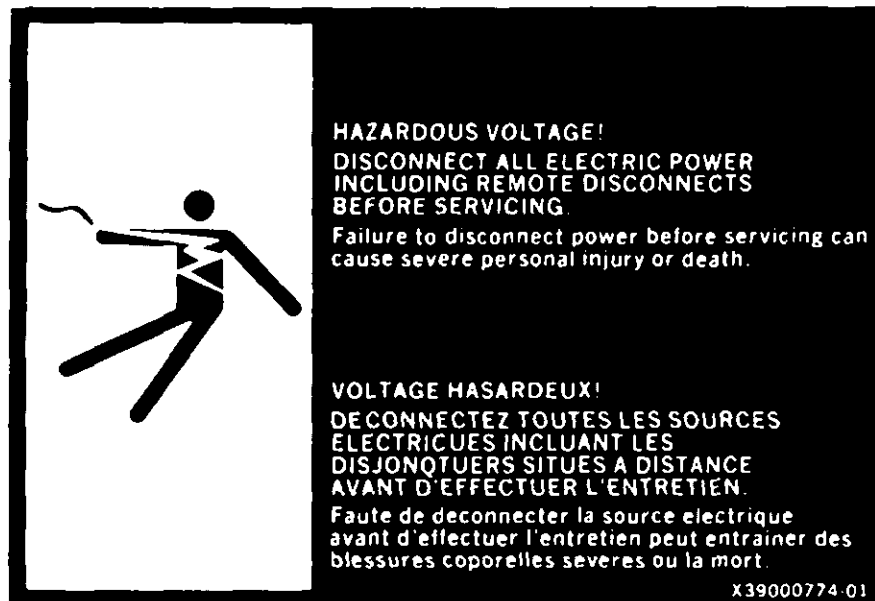


Figure 11  
Typical Field Wiring  
for RTAA Unit

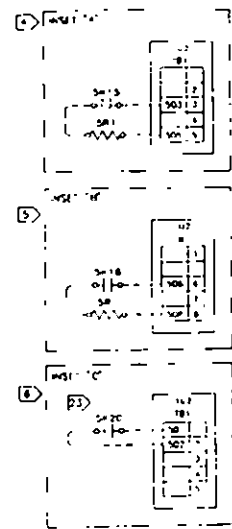
(Continued on  
Next Page)

CUSTOMER WIRE SELECTION TABLE			
POWER WIRE SELECTION TO DISCONNECT SWITCH (151)			
UNIT SIZE	UNIT VOLTAGE	DISCONNECT SWITCH SIZE	CONNECTOR WIRE RANGE
70	700/730	400	(1) - 3/0 TO 250 MCM (2) - 3/0 TO 500 MCM
	348,380	275	3/0 TO 300 MCM
	400,480,575	225	1/0 TO 4/0
80	700/730	400	(1) - 1/0 TO 250 MCM (2) - 3/0 TO 500 MCM
	348,380,400,480	275	3/0 TO 300 MCM
	575	225	1/0 TO 4/0
90	700/730	400	(1) - 1/0 TO 250 MCM (2) - 3/0 TO 500 MCM
	348,380,400,480,575	275	3/0 TO 300 MCM
	700	225	1/0 TO 4/0
100	700/730	400	(1) - 1/0 TO 250 MCM (2) - 3/0 TO 500 MCM
	348,380,400,480,575	275	3/0 TO 300 MCM
	700	225	1/0 TO 4/0
110/125	700/730	400	(1) - 1/0 TO 250 MCM (2) - 3/0 TO 500 MCM
	348,380,400,480	275	3/0 TO 300 MCM
	575	225	1/0 TO 4/0
UNIT SIZE	UNIT VOLTAGE	TERMINAL BLOCK SIZE	CONNECTOR WIRE RANGE
70 - 125	700/730	70	1/0 TO 500 MCM
70 - 125	348,380,400,480,575	333	1/0 TO 350 MCM

FUSE REPLACEMENT SECTION			
FUSE DESCRIPTION	UNIT SIZE	UNIT VOLTAGE	FUSE TYPE
COMPRESSOR FAN FUSE (1111, 112, 117-118)	ALL	ALL	CLASS RK5 (600V) 40 AMP
WATER PUMP AUTO-TRANSFORMER FUSE (1118, 1123)	ALL	350/400/380/50	CLASS CC (600V) 8 AMP
CONTROL CIRCUIT FUSE (1115)	ALL	380/415/348/50	CLASS CC (600V) 8 AMP
POWER CONTROL TRANSFORMER FUSE (11 6-1112)	ALL	200/230V	CLASS CC (600V) 3 AMP
1000 FT	ALL	348,380/575	CLASS CC (600V) 4 AMP
1000 FT	ALL	182V	CLASS CC (600V) 8 AMP
1000 FT	ALL	372V	CLASS CC (600V) 8 AMP
115V & 208V FUSE (1111) UNIT 8 (100V)	ALL	ALL	BUSS CMC-174 LIT FUSE 250/250 0.20 AMP
115V FUSE (100V)	ALL	ALL	BUSS CMC-3110 LIT FUSE 250/300 0.20 AMP
CON FUSE (1277)	ALL	ALL	BUSS CMC 27 C LIT FUSE 275/300 0.20 AMP

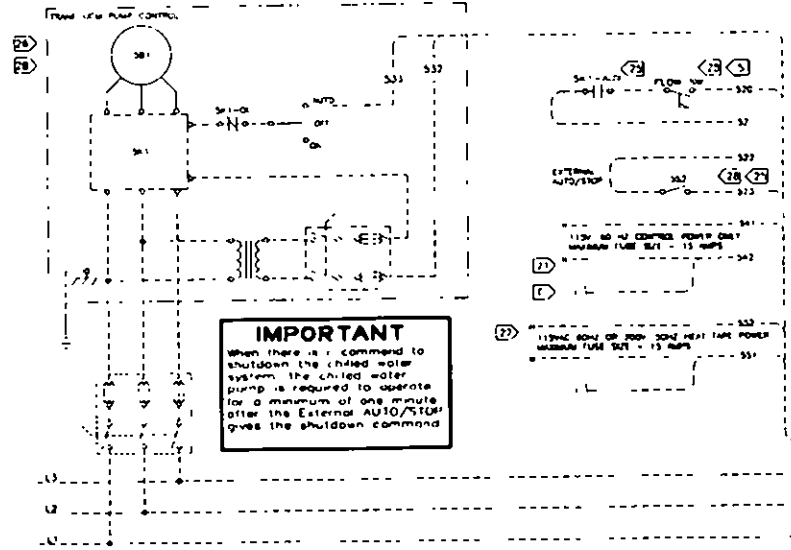
- NOTES
1. DASHED LINES INDICATE RECOMMENDED FIELD WIRING. IF OTHER PROPERLY LISTED ALTERNATE CIRCUITS OR AVAILABLE TABLE OPTIONS CHECKED FIRST ORDER TO DETERMINE IF WIRING IS REQUIRED FOR SPECIFIC OPTIONS.
  2. ALL THREE PHASE WIRING APPLIED WITH THE UNIT ARE PROTECTED UNDER PHASE 2 FAILURE CONDITIONS.
  3. CAUTION - DO NOT EXCEED UNIT WIRE CHECK OUT AND SHUT UP PROCEDURES UNTIL UNIT IS COMPLETED.
  4. SEE WIRE "F" FOR RELEASER CONNECTIONS TO PROGRAM AN EXTENSION CHILLED WATER RESET WHEN 1 - 70 HP OR A B - 10 VOL SCANS IS NOT USED. SEE THE OPERATOR'S MANUAL FOR RELEASER VALUES.
  5. SEE WIRE "E" FOR RELEASER CONNECTIONS TO PROGRAM AN EXTENSION CURRENT UNIT RESET WHEN 1 - 70 HP OR A B - 10 VOL SCANS IS NOT USED. SEE THE OPERATOR'S MANUAL FOR RELEASER VALUES.
  6. SEE WIRE "C" FOR CONTACTS (IN PLACE OF THE ZONE TEMP SENSOR) FOR OPTIONS OF MACHINE CONTROL - OPTION 2.
- THE FOLLOWING CAPABILITIES ARE OPTIONAL. THEY ARE IMPLEMENTED AND WIRED AS REQUESTED FOR A SPECIFIC SYSTEM APPLICATION.
- (A) ALL-MACHINE CONTROL (CANNOT BE USED WITH OPT 1)
  - (B) COMMUNICATIONS INTERFACE
  - (C) PVE-DELTA CLOSED TRANSMISSION STARTER
  - (D) CONTROL POWER TRANSFORMER
  - (E) UNIT DISCONNECT NON-FLUO
  - (F) CHILLED WATER RESET - RETURN WATER
  - (G) CHILLED WATER RESET - OUTDOOR AIR
  - (H) CHILLED WATER RESET - ZONE AIR (CANNOT BE USED WITH OPT 4)
  - (I) LOW AMBER LOCKOUT
  - (J) CHILLED WATER FLOW SWITCH (NOT REQUIRED FOR CHILLER PROTECTION)
  - (K) RESET CLEAR LANGUAGE DISPLAY



**WARNING** HAZARDOUS VOLTAGE! DISCONNECT ALL ELECTRIC POWER INCLUDING REMOTE DISCONNECTS BEFORE SERVICING. FAILURE TO DISCONNECT PROPERLY BEFORE SERVICING CAN CAUSE SEVERE PERSONAL INJURY OR DEATH.

**AVERTISSEMENT** VOL AGÉ HAZARDEUX! DÉCONNECTEZ TOUTES LES SOURCES ÉLECTRIQUES INCLUANT LES DÉCONNECTEURS À DISTANCE AVANT D'EFFECTUER L'ENTRETIEN. FAUTE DE DÉCONNECTER LA SOURCE ÉLECTRIQUE AVANT D'EFFECTUER L'ENTRETIEN PEUT ENTRAINER DES BLESSURES CORPORALES SÉVÈRES OU LA MORT.

**IMPORTANT**  
USE CUMMER CONNECTIONS ONLY TO PREVENT EQUIPMENT DAMAGE! UNIT TERMINALS ARE NOT DESIGNED TO ACCEPT ANY OTHER WIRING.



**IMPORTANT**  
When there is a command to shutdown the chilled water system, the chilled water pump is required to operate for a minimum of one minute after the External AUTO/STOP gives the shutdown command.

**WIRING AND CONNECT REQUIREMENTS**

- 20 ALL FIELD WIRING MUST BE IN ACCORDANCE WITH THE NATIONAL ELECTRICAL CODE (NEC), STATE AND LOCAL REQUIREMENTS, OUTSIDE THE UNITED STATES, SPECIAL COUNTRIES APPLICABLE NATIONAL AND/OR LOCAL REQUIREMENTS SHALL APPLY.
- 21 FOR UNITS WITHOUT THE CONTROL POWER TRANSFORMER (11) OPTION THE CUSTOMER MUST PROVIDE CONTROL POWER OF 115 VAC. 50 HERTZ SHOULD BE USED. 750 VA FOR THE CONTROL POWER TRANSFORMER (11) IS STANDARD ON 30 HERTZ UNITS.
- 22 FOR ALL UNITS, THE HEAT TAP MUST BE POWERED FROM A SEPARATE CUSTOMER PROVIDED 115 VAC, 470 WATT SOURCE FOR 200/230/400/375 30HZ UNITS. 270 WAC 470 WATT SOURCE FOR 240/260/475 30HZ UNITS.
- 23 CUSTOMER SUPPLIED COMPONENTS MUST BE COMPATIBLE WITH DRY CIRCUIT 1 INCH. 1/8 INCH WELDED LEAD BRIDGE OR GOLD PLATED CONTACTS ARE RECOMMENDED.
- 24 30 VOLT OR LESS CIRCUIT DO NOT RUN IN CONDUCT WITH HIGHER VOLTAGE CIRCUITS, USE #14-18 AWG. SEE SELECTION TABLE.
- 25 MINIMUM PLUG OUT CONTACT RATING AT 115 VAC 8 AMP. MAXIMUM 1/2 INCH SPACED.
- 26 FIELD WIRED ELECTRICAL LOADS IS NOT TO EXCEED THE FOLLOWING RATINGS:
 

TERMINAL	DEVICE	VOLTAGE	MAXIMUM VA	MINIMUM W
101-78A-1	115 V AC	115	180	1.50
101-78A-2	115 V AC	115	180	1.50
101-78A-3	115 V AC	115	180	1.50
101-78A-4	115 V AC	115	180	1.50
101-78A-5	115 V AC	115	180	1.50
101-78A-6	115 V AC	115	180	1.50
101-78A-7	115 V AC	115	180	1.50
101-78A-8	115 V AC	115	180	1.50
101-78A-9	115 V AC	115	180	1.50
101-78A-10	115 V AC	115	180	1.50
- 27 STANDARD PLUG OUT RATING (SEE POWER FACTOR)
- 28 IF EXTERNAL CIRCUIT BREAKER IS USED ON CIRCUIT #1 AND CIRCUIT #2, THE WIRE TO THE INTERNAL CIRCUIT BREAKER OF THE JUMPER FOR CIRCUIT #1 AND CIRCUIT #2 MUST BE CONNECTED TO THE INTERNAL CIRCUIT BREAKER.
- 29 CHILLED WATER PUMP CONTROL FROM TRIM UNIT NEW MODULE CHILLED WATER PUMP IS REQUIRED TO OPERATE A MINIMUM OF 1 MINUTE AFTER A COOLING IC TERMINAL CHILLER OPERATION (ICM) HAS PROVIDED THE CHILLER CONTROL. CHILLED WATER SYSTEM DEMAND SWITCH (132) IS CONNECTED TO THE LOW FREQUENCY AUTO/STOP INPUT.
- 30 20 AMPERES 240V 2 WIRE LINE TRANSFORMER 11-(OPTIONAL) IS USED FOR 115 VOLT OPERATION IF UNIT IS TO BE OPERATED ON A 240 VOLT POWER SUPPLY. IT IS CONNECTED AS SHOWN IN WIRE TO BE PROVIDED. LINE VOLTAGE IS SERVICE LITING WIRE OF CLEAR LANGUAGE OPERATE FROM 415 TO 380.
- 31 115 VOLT RELAY OUTPUTS CAN BE PROGRAMMED TO PERFORM ALTERNATE FUNCTIONS. SEE INSTALLATION OPERATION & MAINTENANCE MANUAL FOR DETAILS (FUNCTION #1 & 2).

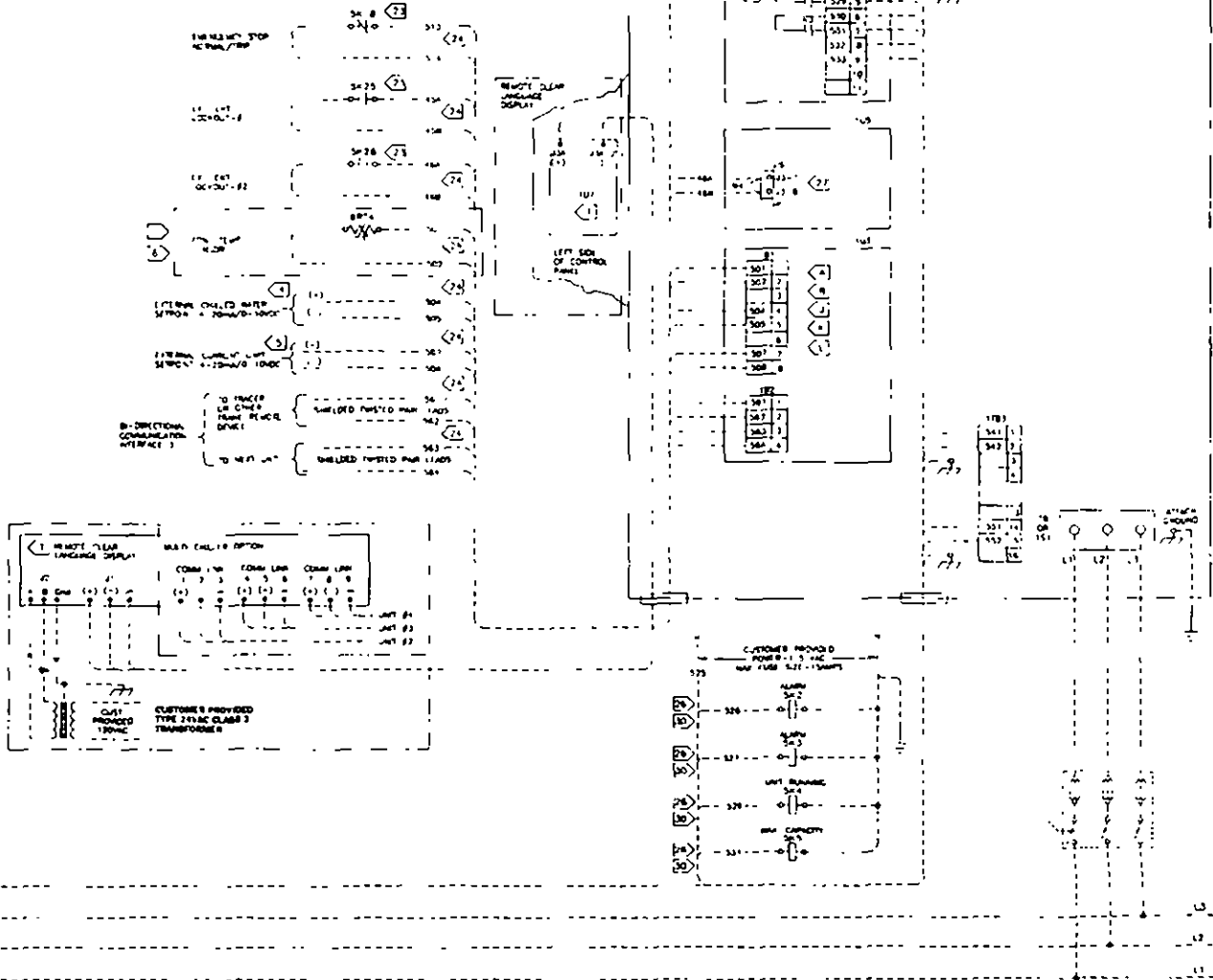
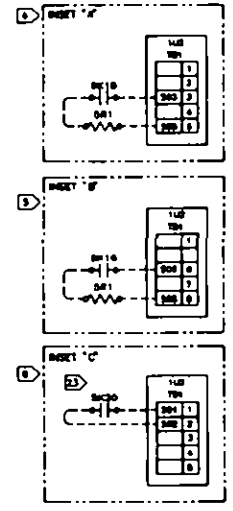


Figure 11a  
Typical Field Wiring  
for RTAA Unit with  
Remote Evaporator

(Continued on  
Next Page)

CUSTOMER WIRE SELECTION TABLE				
POWER WIRE SELECTION TO DISCONNECT SWITCH (178)				
UNIT SIZE	UNIT VOLTAGE	DISCONNECT SWITCH SIZE	CONNECTOR WIRE RANGE	
70	200,230	400	(1) - 3/8 TO 3/4 MCM (2) - 3/8 TO 5/8 MCM	
	348,380	725	3/8 TO 3/4 MCM	
	400,480,575	725	3/4 TO 1/2"	
80	200,230	400	(1) - 3/8 TO 3/4 MCM (2) - 3/8 TO 5/8 MCM	
	348,380,400,480	725	3/8 TO 3/4 MCM	
	575	725	3/4 TO 1/2"	
90	200	400	(1) - 3/8 TO 3/4 MCM (2) - 3/8 TO 5/8 MCM	
	230,348,380	400	(1) - 3/8 TO 3/4 MCM (2) - 3/8 TO 5/8 MCM	
	400,480,575	725	3/8 TO 3/4 MCM	
100	200	400	(1) - 3/8 TO 3/4 MCM (2) - 3/8 TO 5/8 MCM	
	230	400	(1) - 3/8 TO 3/4 MCM (2) - 3/8 TO 5/8 MCM	
	348,380	400	(1) - 3/8 TO 3/4 MCM (2) - 3/8 TO 5/8 MCM	
110,125	400,480,575	725	3/8 TO 3/4 MCM	
	200,230	400	(1) - 3/8 TO 3/4 MCM (2) - 3/8 TO 5/8 MCM	
	348,380,400,480	400	(1) - 3/8 TO 3/4 MCM (2) - 3/8 TO 5/8 MCM	
	575	725	3/8 TO 3/4 MCM	
POWER WIRE SELECTION TO MAIN TERMINAL BLOCK (176)				
UNIT SIZE	UNIT VOLTAGE	TERMINAL BLOCK SIZE	CONNECTOR WIRE RANGE	
70 - 125	200,230	780	1/2 TO 3/4 MCM	
70 - 125	348,380,400,480,575	520	1/2 TO 3/4 MCM	
CONTROL WIRE SELECTION FOR 30 VOLT OR LESS CIRCUITS - SEE NOTE 24				
WIRE SIZE	MAXIMUM LENGTH FOR WIRE RUN			
14 AWG	3000 FT			
18 AWG	2000 FT			
18 AWG	1000 FT			
FUSE REPLACEMENT SECTION				
FUSE DESCRIPTION	UNIT SIZE	UNIT VOLTAGE	FUSE TYPE	FUSE SIZE
CONDENSER FAN FUSE (171-173, 177-179)	ALL	ALL	CLASS RC3(800V)	40 AMP
INVERTER/AUTO-TRANSFORMER FUSE (171b-172)	ALL	0/70V/480V/200V/90	CLASS CC (600V)	6 AMP
CONTROL CIRCUIT FUSE (171)	ALL	200/230V/348/380	CLASS CC (600V)	10 AMP
POWER CONTROL TRANSFORMER FUSE (171b-171)	ALL	200/230V	CLASS CC (600V)	5 AMP
		348/380/415	CLASS CC (600V)	4 AMP
		480V	CLASS CC (600V)	4 AMP
1000 FT		375V	CLASS CC (600V)	4 AMP
CPM & MCSP FUSE (14U1 & 14U1)	ALL	ALL	BUSF CMC-1/4 LITTLEFUSE 230,250	0.25 AMP 5x20mm
DRY FUSE (14U1)	ALL	ALL	BUSF CMC-5/16 LITTLEFUSE 230,300	0.30 AMP 5x20mm
CSR FUSE (14U2)	ALL	ALL	BUSF CMC-2/16 LITTLEFUSE 230,300	0.20 AMP 5x20mm

- NOTES
1. DIMENSIONS INDICATED RECOMMENDED FIELD WIRING BY OTHER MANUFACTURERS. VERIFY ALTERNATE CIRCUITRY OR AVAILABLE SALES OFFICE. CHECK WIRING ORDER TO DETERMINE IF WIRING IS REQUIRED FOR SPECIFIC OPTIONS.
  2. ALL THREE PHASE WIRING SUPPLIED WITH THE UNIT ARE PROTECTED UNDER FUSE/178. INSURE CORRECT.
  3. CAUTION - DO NOT DISCONNECT UNIT LINE ON/OFF AND STOP-UP PROCEDURES MUST BE COMPLETED.
  4. SEE NOTE "F" FOR REPAIR CONNECTIONS TO PROGRAM AN EXTERNAL CHILLED WATER SYSTEM WHEN 4 - 30 PSI OR A 2 - 10 MIC BUBBLER IS USED. SEE THE OPERATING MANUAL FOR REPAIR VALUES.
  5. SEE NOTE "F" FOR REPAIR CONNECTIONS TO PROGRAM AN EXTERNAL CHILLED WATER SYSTEM WHEN 4 - 30 PSI OR A 2 - 10 MIC BUBBLER IS NOT USED. SEE THE OPERATING MANUAL FOR REPAIR VALUES.
  6. SEE NOTE "C" FOR CONDUIT OR PLACE OF THE FUSE TRIP SWITCH FOR OPTIONS. SEE BEFORE ORDERING - OPTION "F".
- THE FOLLOWING OPTIONS ARE OPTIONAL - THEY ARE SUPPLEMENTARY AND NEED AS REQUIRED FOR A SPECIFIC SYSTEM APPLICATION.
- A ICE-MAKE CONTROL (CANNOT BE USED WITH OPT. J)
  - B COMMERCIAL SERVICE
  - C ONE-HELIUM CHARGED INVERTER CHARGER
  - D CONTROL POWER TRANSFORMER
  - E UNIT DISCONNECT, NON-FUSED
  - F CHILLED WATER HEAT - RETURN SIDE
  - G CHILLED WATER HEAT - OUTDOOR AIR
  - H CHILLED WATER HEAT - EXH. AIR (CANNOT BE USED WITH OPT. A)
  - I LOW AMBIENT LOCKOUT
  - J CHILLED WATER FLOW SWITCH (NOT REQUIRED FOR CHILLED PROTECTION)
  - K REMOVE CLEAR LANGUAGE SWITCH



**⚠ WARNING    ⚠ AVERTISSEMENT**

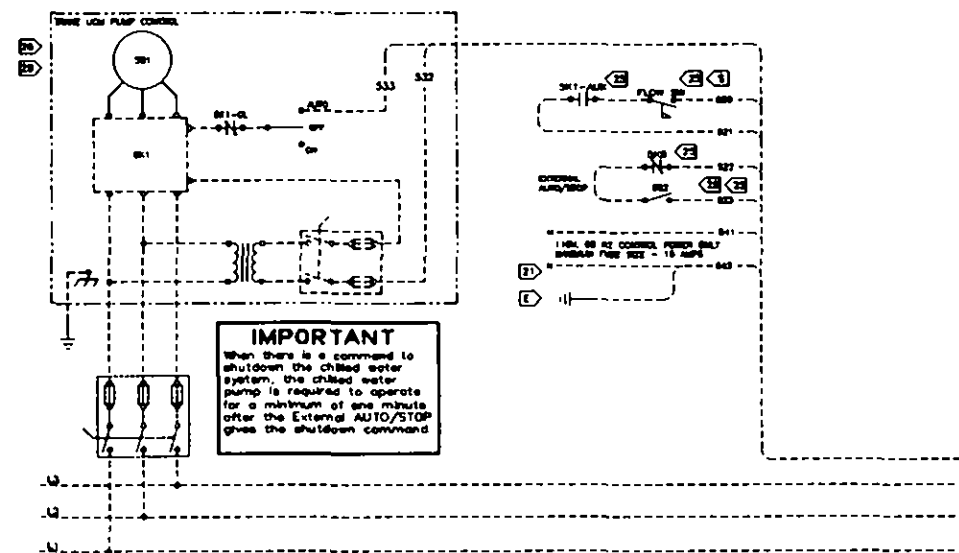
**HAZARDOUS VOLTAGE    VOLTAGE HASARDEUX**

DISCONNECT ALL ELECTRIC POWER INCLUDING REMOTE DISCONNECTS BEFORE SERVICING.    DECONNECTEZ TOUTES LES SOURCES ELECTRIQUES INCLUANT LES DISJONCTEURS SITUES A DISTANCE AVANT D'EXECUTER L'ENTRETIEN.

FAILURE TO DISCONNECT POWER BEFORE SERVICING CAN CAUSE SEVERE PERSONAL INJURY OR DEATH.    FAUTE DE DECONNECTER LA SOURCE ELECTRIQUE AVANT D'EXECUTER L'ENTRETIEN PEUT ENTRAÎNER DES BLESSURES CORPORELLES SEVERES OU LA MORT.

**IMPORTANT**

USE COPPER CONDUCTORS ONLY TO PREVENT EQUIPMENT DAMAGE. UNIT TERMINALS ARE NOT DESIGNED TO ACCEPT ANY OTHER WIRING.



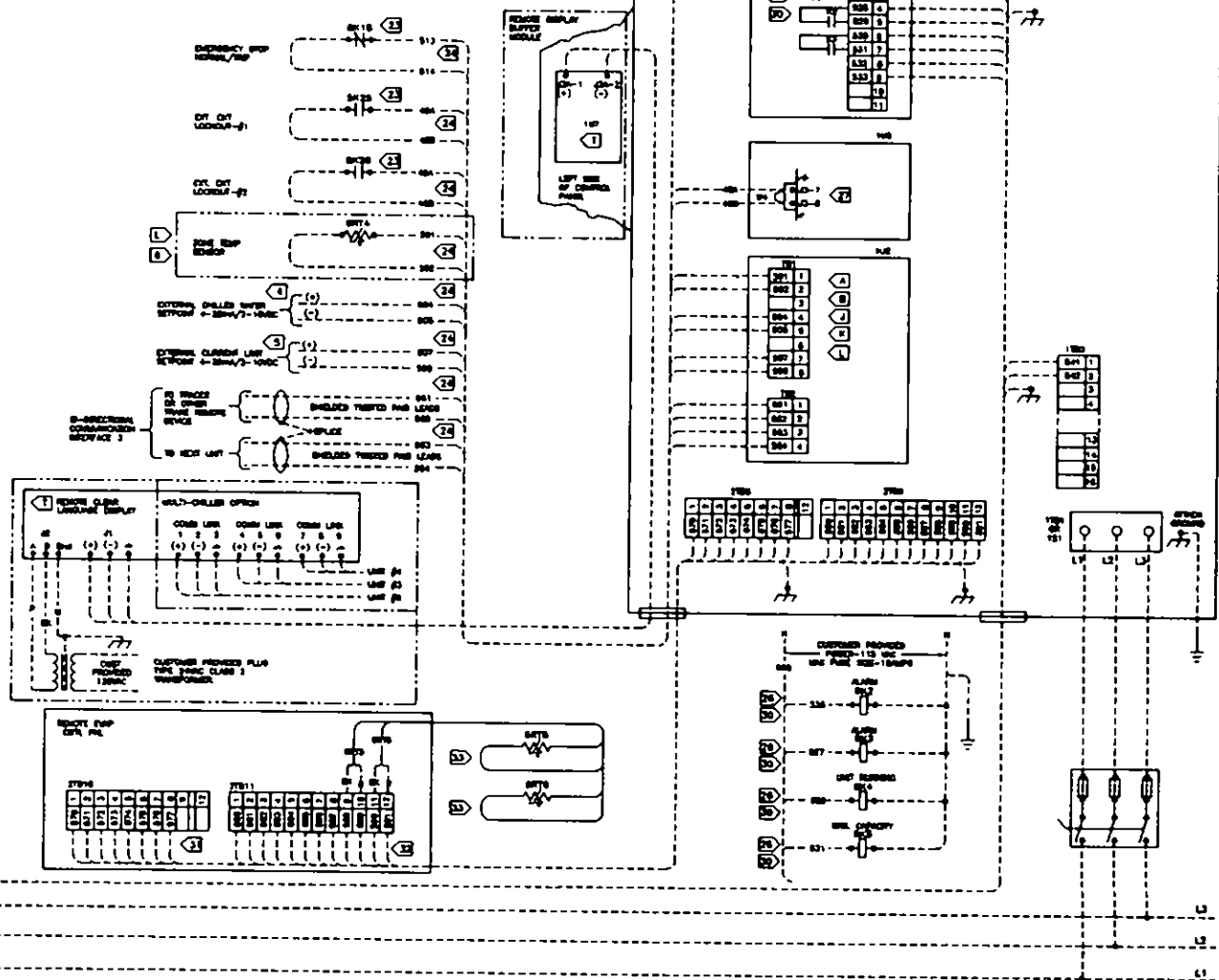
**WIRE AND CONNECT REQUIREMENTS**

- 20 ALL WIRE WIRING MUST BE IN ACCORDANCE WITH THE APPLICABLE ELECTRICAL CODE (NEC, NEMA AND LOCAL REQUIREMENTS), EXCEPT THE WIRING SHALL ONLY COMPLY APPLICABLE FEDERAL AND/OR LOCAL REQUIREMENTS THAT APPLY.
- 21 FOR LAMP WIRING THE CONTROL POWER TRANSFORMER (17) OPTION, THE CUSTOMER MUST PROVIDE CONTROL POWER OF 115 VAC, 15 AMP, 50/60 HERTZ, 70 TO 80 IN CONTROL POWER TRANSFORMER (17) IS PROVIDED ON 30 AMP LAMP.
- 22 CUSTOMER SUPPLIED CONTACTS MUST BE COMPATIBLE WITH ANY CIRCUIT BREAKER, AREA CONTROL LOAD, SLIP-ON GOLD PLATED CONTACTS ARE RECOMMENDED.
- 23 20 VOLT OR LESS CIRCUIT, DO NOT RUN IN CONTACT WITH HIGHER VOLTAGE CIRCUIT, USE #14-16 AWG, SEE SELECTION TABLE.
- 24 MINIMUM PLUG ONLY CONTACT RATING IS 115 VOLT, 15 AMP, 1.25 WELDED.
- 25 FIELD WIRE ELECTRICAL LEADERS IS USE TO CROSS THE FOLLOWING APPROX:

TERMINAL	WIRING	VOLTAGE	WELDED IN	MINIMUM IN
WT-100-1,3	PLUG/SLIP	115	150	1150
WT-100-4,5	PLUG/SLIP	115	150	1150
WT-100-6,7	PLUG/SLIP	115	150	1150
WT-100-8,9	PLUG/SLIP	115	200	1150
WT-100-10,11	PLUG/SLIP	115	150	1150

- 26 1. STANDARD PLUG ONLY CONTACT FACTORY.
- 27 1. STANDARD CONTACT LOCKING IS USED ON Ckt 1. Ckt 2 AND 3 ARE NOT USED ON Ckt 4 AND 5. Ckt 6 AND 7 ARE NOT USED ON Ckt 8 AND 9. Ckt 10 AND 11 ARE NOT USED ON Ckt 12 AND 13.
- 28 CHILLED WATER PUMP CONTROL FROM TRIP UNIT LOGIC MODULE, CHILLED WATER PUMP IS REQUIRED TO OPERATE A MINIMUM OF 1 SECONDS AFTER A COMMAND TO STOP/START CHILLED WATER PUMP. CHILLED WATER PUMP CONTROL FROM TRIP UNIT LOGIC MODULE, CHILLED WATER PUMP IS REQUIRED TO OPERATE A MINIMUM OF 1 SECONDS AFTER A COMMAND TO STOP/START CHILLED WATER PUMP.
- 29 AS SHIPPED 200/115 VOLT LIGHT TRANSFORMER (17) (OPTIONAL) IS USED FOR 115 VOLT CIRCUIT, IF WIRE IS TO BE CHANGED ON A 200 VOLT POWER SUPPLY, RE-CONNECT AS SHOWN IN WIRING OPTION, USE LOW VOLTAGE OF WIRING OPTION, WIRE OF CLEAR LABELING, MINIMUM WIRE #14 TO #16.
- 30 11, 12, 13, 14 RELAY CIRCUITS CAN BE PROGRAMMED TO PROVIDE ALTERNATE FUNCTIONS, SEE INSTALLATION MANUAL, 3. PERFORMANCE TABLE FOR DETAILS, FUNCTION #1 IS SHOWN.

- 31 RECOMMEND WIRE 4 AWG OF 2 CONDUCTOR, #14 AWG, ONLY 40°C, WIRE ENDED WITH OVER THE SHEATH END OF INSULATION, DO NOT RUN IN CONTACT WITH HIGHER VOLTAGE CIRCUIT.
- 32 RECOMMEND WIRE 3 AWG OF 3 CONDUCTOR, #14 AWG, ONLY 40°C, WIRE ENDED WITH OVER THE SHEATH END OF INSULATION, DO NOT RUN IN CONTACT WITH HIGHER VOLTAGE CIRCUIT.
- 33 REFER TO INSTALLATION LABEL, LOCATED BEHIND COVER OF TRIP UNIT (TRIP/POWER CONTROL PANEL).





**Table 3  
Electrical Data**

Unit Size	Unit Wiring				Motor Data						
	Rated Voltage	MCA (2)	MOP (1)	Rec Time Delay or RDE (3)	Qty.	Compressor (Ea) RLA (4)	LRA (7)	Qty.	Fans (Ea) KW	FLA	Control KW (6)
RTAA 70	200/60	300	400	350	2	115/115	800/800	8	1.0	5.1	0.75
	230/60	265	350	300	2	100/100	690/690	8	1.0	5.0	0.75
	460/60	133	175	150	2	50/50	330/330	8	1.0	2.5	0.75
	575/60	108	125	125	2	40/40	270/270	8	1.0	2.2	0.75
	346/50	153	200	175	2	58/58	390/390	8	1.0	2.7	0.75
	400/50	133	175	150	2	50/50	325/325	8	1.0	2.5	0.75
RTAA 80	200/60	361	500	400	2	142/142	800/800	8	1.0	5.1	0.75
	230/60	319	400	350	2	124/124	760/760	8	1.0	5.0	0.75
	460/60	160	200	175	2	62/62	380/380	8	1.0	2.5	0.75
	575/60	131	175	150	2	50/50	304/304	8	1.0	2.2	0.75
	346/50	184	250	225	2	72/72	430/430	8	1.0	2.7	0.75
	400/50	160	200	175	2	62/62	375/375	8	1.0	2.5	0.75
RTAA 90	200/60	428	600	500	2	192/192	990/880	9	1.0	5.1	0.75
	230/60	378	500	450	2	167/167	820/760	9	1.0	5.0	0.75
	460/60	190	250	225	2	84/84	410/380	9	1.0	2.5	0.75
	575/60	154	200	175	2	67/67	328/304	9	1.0	2.2	0.75
	346/50	217	300	250	2	96/96	485/430	9	1.0	2.7	0.75
	400/50	190	250	225	2	84/84	402/375	9	1.0	2.5	0.75
RTAA 100	200/60	483	600	500	2	192/192	990/990	10	1.0	5.1	0.75
	230/60	426	500	500	2	167/167	820/820	10	1.0	5.0	0.75
	460/60	214	250	250	2	84/84	410/410	10	1.0	2.5	0.75
	575/60	173	225	200	2	67/67	328/328	10	1.0	2.2	0.75
	346/50	243	300	300	2	96/96	485/485	10	1.0	2.7	0.75
	400/50	214	250	250	2	84/84	402/402	10	1.0	2.5	0.75
RTAA 110	200/60	535	700	600	2	233/192	1190/990	10	1.0	5.1	0.75
	230/60	471	600	600	2	203/167	1044/820	10	1.0	5.0	0.75
	460/60	235	300	300	2	101/84	522/410	10	1.0	2.5	0.75
	575/60	191	250	225	2	81/67	420/328	10	1.0	2.2	0.75
	346/50	270	300	300	2	117/96	585/485	10	1.0	2.7	0.75
	400/50	236	300	300	2	101/84	512/402	10	1.0	2.5	0.75
RTAA 125	200/60	576	800	700	2	233/233	1190/1190	10	1.0	5.1	0.75
	230/60	507	700	600	2	203/203	1044/1044	10	1.0	5.0	0.75
	460/60	253	350	300	2	101/101	522/522	10	1.0	2.5	0.75
	575/60	205	250	225	2	81/81	420/420	10	1.0	2.2	0.75
	346/50	291	400	350	2	117/117	585/585	10	1.0	2.7	0.75
	400/50	253	350	300	2	101/101	512/512	10	1.0	2.5	0.75

**Notes**

- (1) MOP - Maximum Overcurrent Protection - may be either fused/HACR type breaker (UL/CSA) or with circuit breakers (CSA only) MOP = 225 percent of the largest compressor RLA plus 100 percent of the second compressor RLA plus the sum of the condenser fans FLAs per NEC 440.22
- (2) MCA - Minimum Circuit Ampacity - 125 percent of largest compressor RLA plus 100 percent of second compressor plus the sum of the condenser fans FLAs per NEC 440.33
- (3) RECOMMENDED TIME DELAY OR DUAL ELEMENT (RDE) FUSE SIZE - 150 percent of the largest compressor RLA plus 100 percent of the second compressor RLA and the sum of the condenser fan FLAs
- (4) RLA - Rated Load Amps - rated in accordance with UL Standard 465
- (5) Local codes may take precedence
- (6) Control kw includes operational controls only. Does not include heat tapes
- (7) LRA - Locked Rotor Amps - based on full winding start units
- (8) VOLTAGE UTILIZATION RANGE
 

Rated Voltage	Utilization Range
200/60	180-220
230/60	208-254
460/60	414-506
575/60	516-633
346/50	311-381
400/50	340-460
- (9) 60 HZ UNITS - A 115/60/1 15 amp customer provided power connection is required to operate the unit controls. A separate 115/60/1, 15 amp customer provided power connection is also needed to power the evaporator heat tape (420 watts @ 120 volts) if the optional control power transformer is used, the customer needs only to provide a power connection for the heat tapes
- (10) 50 HZ UNITS - A separate 220/50/1 15 amp customer provided power connection is also needed to power evaporator heat tape (420 watts @ 220 volts)

Do not allow conduit to interfere with other components, structural members or equipment.

Control voltage (115V) wiring in conduit must be separate from conduit carrying low voltage (<30V) wiring

**Caution: To prevent control malfunctions, do not run low voltage wiring (<30V) in conduit with conductors carrying more than 30 volts.**

### Installer-Supplied Components

**Caution: Customer wiring interface connections are shown in the electrical schematics and connection diagrams that are shipped with the unit.**

The installer must provide the following components if not ordered with the unit

- [ ] Power supply wiring (in conduit) for all field-wired connections
- [ ] All control (interconnecting) wiring (in conduit) for field supplied devices.
- [ ] Fused-disconnect switches.
- [ ] Power factor correction capacitors.

Remote Evaporator Only:

- [ ] Control wiring between the outdoor unit and the evaporator terminal box

## Power Supply Wiring

### General

All power supply wiring must be sized and selected accordingly by the project engineer in accordance with the National Electrical Code.

**WARNING: To prevent injury or death, disconnect electrical power source before completing wiring connections to the unit.**

All wiring must comply with local codes and the National Electrical Code. The installing (or electrical) contractor must provide and install the system interconnecting wiring, as well as the power supply wiring. It must be properly sized and equipped with the appropriate fused-disconnect switches. The type and installation location(s) of the fused-disconnects must comply with all applicable codes.

**Caution: Use only copper conductors for terminal connections to avoid corrosion or overheating.**

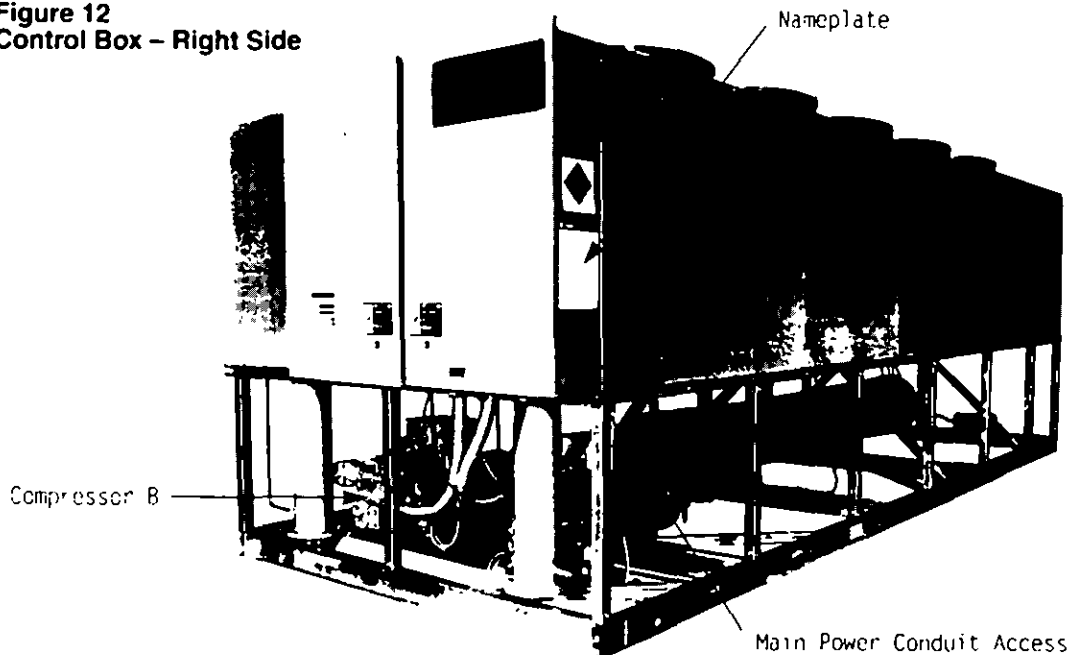
Cut holes for the appropriately-sized wiring conduits in the lower right side of the power connection panel. The wiring is passed through these conduits and connected to the terminal blocks or optional unit-mounted disconnect. Refer to Figure 1 and Figure 12.

To provide proper phasing of 3-phase input, make connections as shown in Figure 11 and as stated on the yellow WARNING label in the starter panel. For additional information on proper phasing, refer to "Unit Voltage Phasing". Proper equipment ground must be provided to each ground connection in the panel

## WARNING

IT IS IMPERATIVE THAT L1-L2-L3 IN THE STARTER BE CONNECTED IN THE A-B-C PHASE SEQUENCE TO PREVENT EQUIPMENT DAMAGE DUE TO REVERSE ROTATION.

**Figure 12**  
**Control Box – Right Side**



---

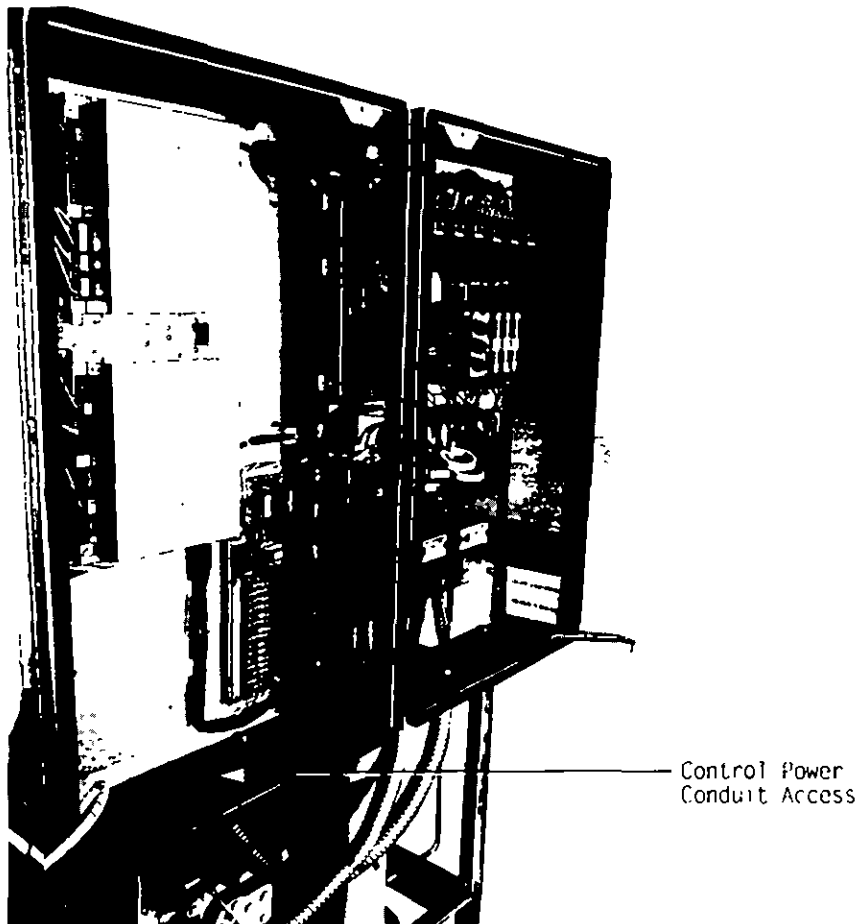
### Control Power Supply

If the unit is equipped with the optional control power transformer, it is not necessary to provide control power voltage to the unit.

If the transformer is not provided, connect control power (115V, 750VA, 15 amp maximum fuse size) to terminals 1TB3-1 and 1TB3-2, as shown in Figure 13.

**Caution: 380/415 volt units are factory connected as 415 volt units. For 380 volt units, the leads must be moved to the appropriate terminals on the transformer (1T1). See Unit Wiring Diagrams. Reprogram "Unit Line Voltage" (Service Setting Menu) to 380.**

**Figure 13**  
**Control Box — Front**



---

## Heat Tape Power Supply (Packaged Units Only)

**Note:** Units with the Remote Evaporator option do not have heat tape.

The evaporator shell is insulated from ambient air and protected from freezing temperatures by a thermostatically-controlled heat tape. Whenever the chilled water temperature drops to approximately 37 F, the thermostat energizes the heat tape. The heat tape will protect the evaporator from ambient temperatures down to -20 F.

Provide an independent power source (115V, 15 amp), with a fuse disconnect. The heat tape is factory wired back to the unit control panel. Customer connections are made on terminal strip 1TB3, terminals 14 and 15

## Water Pump Power Supply

Provide power supply wiring with fused-disconnect for the chilled water pump(s).

## Interlock Wiring

**Caution: The chiller water pump must operate for a minimum of one minute after the UCM receives a command through the external Auto/Stop input to shut down the chilled water system. Do not use the proof of chiller water flow interlock (1U1TB3-1 and -2) by itself as the normal means of terminating chiller operation.**

Normally, when the compressors are terminating a cycle (when chiller Stop key, loss of load, low ambient run inhibit, or external Auto/Stop), the controller will initiate the "Run: UNLOAD" mode. This operating mode commands the compressors to their complete unloaded position, which takes about 1/2 minute. This will allow the compressor to be totally unloaded for the next start-up. If only the proof of chilled water flow interlock is used, the chiller will shut down on an immediate (non-friendly) shutdown and initiate an automatic reset diagnostic.

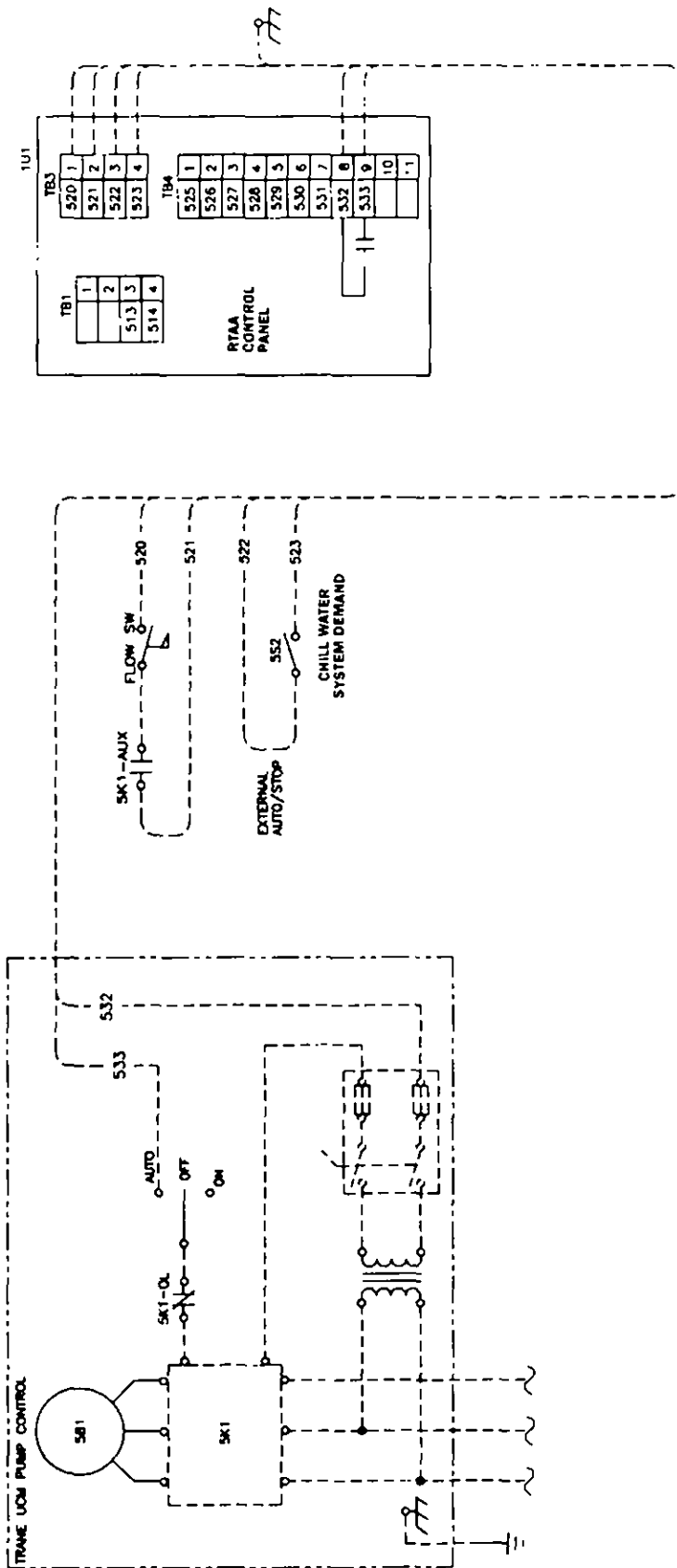
Figure 14 shows a typical interlock of an RTAA chiller. There are three points (six wires) on the chiller that are required to be connected.

1. External Auto/Stop (Terminals 1U1TB3-3 and -4). This input would be supplied by the field. A contact closure would start the chiller water pump and chiller, via the UCM pump control contacts. Opening the contact would put the operating compressors into the "RUN:UNLOAD" mode and initiate a timing period (1 to 30 minutes, adjustable through the Clear Language Display). This will delay termination of chilled water pump operation via the UCM pump control contacts. Examples of the input at terminals 1U1TB3-3 and -4 would be a time clock, ambient thermostat, building automation system, etc.

2. UCM Pump Control Contacts (Terminals 1U1TB4-8 and -9). This output is a set of contacts that will close and start the chilled water pump when the external auto/stop contacts are closed. When the contacts are opened, 1 to 30 minutes later (adjustable through the Clear Language Display) the UCM pump contacts open.

3. Proof of Chilled Water Flow Interlock (Terminals 1U1TB3-1 and -2). This terminal must be field installed. Contact closure between the terminals indicates proof of chilled water flow. Examples of this would be a pump starter auxiliary contact, flow switch, differential pressure switch, or a contact from a building automation system (see Chilled Water Flow Switch in the Water Piping section of this manual). Opening of this contact would immediately shutdown the chiller and initiate an automatic reset diagnostic indicating loss of chilled water flow.

**Figure 14**  
**Typical RTAA Chiller Interlock**



### Alarm/Running/Maximum Capacity Outputs

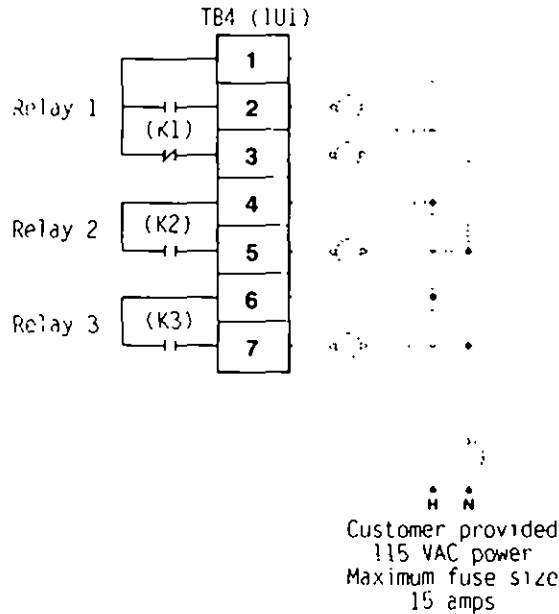
Terminals 1 to 7 on terminal strip TB4 of the 1U1 board provide a variety of contact outputs. These are dependent upon the setting of Programmable Relay Setup ("Service Setting Menu") and its relationship to diagnostics, compressors operating and the system operating at full capacity.

As shown in Figure 15, there are three relays. Relay 1 has SPDT contacts. Relays 2 and 3 have SPST normally-open contacts. The relays can provide three different output configurations, as shown in Table 4, and each configuration offers four choices as to how the alarm relay is to respond to a set of diagnostics.

Table 5 shows the twelve settings available in Programmable Relay Setup ("Service Settings Menu") and the diagnostics which are issued for each set of conditions

1U1TB4 on the UCM, as shown in Figure 11. Refer to the field diagrams which are shipped with the unit.

**Figure 15**  
Alarm/Running/Maximum Capacity Contact Outputs



**Table 4**  
Alarm/Running/Maximum Capacity Relay Output Configurations

Relay Output Configuration	
1:	RLY 1 - Alarm RLY 2 - Compressor Running RLY 3 - Maximum Capacity
2:	RLY 1 - Circuit 1 Alarm RLY 2 - Circuit 2 Alarm RLY 3 - Maximum Capacity
3:	RLY 1 - Alarm RLY 2 - Circuit 1 Running RLY 3 - Circuit 2 Running

### Alarm/Running/Maximum Capacity Indicator Wiring

If the optional remote Alarm/Running/Maximum Capacity contacts are used, provide electrical power, 115 VAC (contact load not to exceed 1150 VA inrush, 115 VA sealed), with fused-disconnect to a customer-furnished remote device. Also provide proper remote device ground connections.

To install the available remote running and alarm indication, the installer must provide leads 525 thru 531 from the panel to the proper terminals of terminal strip

**Table 5**  
Alarm/Running/Maximum Capacity Menu Settings

Programmable Relay Setup Setting (Service Setting Menu)	Relays Output Configuration (Table 4)	Diagnostics that the Alarm Relay(s) is Active		
		MMR/ CMR diag.	MAR/ CAR diag.	IFW
1	1	YES	NO	NO
2	1	YES	YES	NO
3	1	YES	YES	YES
4	1	YES	NO	YES
5	2	YES	NO	NO
6	2	YES	YES	NO
7	2	YES	YES	YES
8	2	YES	NO	YES
9	3	YES	NO	NO
10	3	YES	YES	NO
11	3	YES	YES	YES
12	3	YES	NO	YES

Notes  
MMR = Machine Manual Reset  
CMR = Circuit Manual Reset  
MAR = Machine Auto Reset  
CAR = Circuit Auto Reset  
IFW = Informational Warnings

## Low Voltage Wiring

The remote devices described below require low voltage wiring. All wiring to and from these remote input devices to the UCM must be made with shielded, twisted-pair conductors. Be sure to ground the shielding only at the Clear Language Display. See Figure 11 for the recommended conductor sizes.

**Caution: To prevent control malfunctions, do not run low voltage wiring (<30 V) in conduit with conductors carrying more than 30 volts.**

### Emergency Stop (Normal Trip)

The Clear Language Display provides auxiliary control for a customer specified/ installed latching tripout. When this customer-furnished remote contact (5K18) is provided, the chiller will run normally when the contact is closed. *When the contact opens, the unit will trip off on a manually resettable diagnostic.* This condition requires manual reset at the chiller switch on the front of the Clear Language Display.

To connect, first remove the jumper located between terminals 3 and 4 of 1U1TB1. Connect low voltage leads 513 and 514 to those terminals. Terminal strip locations are shown in Figure 11. Refer to the field diagrams which are shipped with the unit.

Silver or gold-plated contacts are recommended. These customer-furnished contacts must be compatible with 12 VDC, 45 mA resistive load.

### External Circuit Lockout – Circuit #1

The UCM provides auxiliary control of a customer specified or installed contact closure, for individual operation of Circuit #1. If the contact is closed, the refrigerant circuit will not operate. The refrigerant circuit will run normally when the contact is opened. This feature is used to restrict total chiller operation, eg during emergency generator operations.

External circuit lockout will only function if External Circuit Lockout (Service Setting Menu) is enabled.

These customer-supplied contact closures must be compatible with 12 VDC, 45 mA resistive load. Silver or gold plated contacts are recommended.

To install, cut, strip and wire-nut existing wire loop #W7 on the P43 connector of the 1U4 module to low voltage leads 45A and 45B. Connections are shown in the field diagrams which are shipped with the unit.

### External Circuit Lockout – Circuit #2

The UCM provides auxiliary control of a customer specified or installed contact closure, for individual operation of Circuit #2. If the contact is closed, the refrigerant circuit will not operate. The refrigerant circuit will run normally when the contact is opened. This feature is used to restrict total chiller operation, eg during emergency generator operations.

External circuit lockout will only function if External Circuit Lockout (Service Setting Menu) is enabled.

These customer-supplied contact closures must be compatible with 12 VDC, 45 mA resistive load. Silver or gold plated contacts are recommended.

To install, cut, strip and wire-nut existing wire loop #4 on the P53 connector of the 1U5 module to low voltage leads 46A and 46B. Connections are shown in the field diagrams which are shipped with the unit.

### Ice Making Option

Ice Machine Control (Operator Settings Menu) must be Enabled. The UCM provides auxiliary control for a customer specified/installed contact closure for ice making. When contact (5K20) is provided, the chiller will run normally when the contact is open. Upon contact closure, the UCM will initiate an ice-building mode, in which the unit runs fully loaded at all times. Ice-building shall be terminated either by opening the contact or based on the entering evaporator water temperature setting under Active Ice Termination Setpoint (Chiller Report Menu). The UCM will not permit the ice-building mode to be reentered until the unit has been switched out of ice-building mode (open 5K20 contacts) and then switched back into ice building mode (close 5K20 contacts).

In ice-building, the current setpoint will be set at 120%. For example, if the Front Panel or External Current Limit setpoint is set to 80%, in ice-building the Active Current Limit is 120%.

If, while in ice-building mode, the unit gets down to the freezestat setting (water or refrigerant), the unit will shut down on a manually resettable diagnostic, just as in normal operation.

Connect leads 501 and 502 from 5K20 to the proper terminals 1U2TB1-1 and -2, as shown in Figure 12. Refer to the field diagrams which are shipped with the unit.

Silver or gold-plated contacts are recommended. These customer furnished contacts must be compatible with 12 VDC, 45 mA resistive load.

### External Chilled Water Setpoint (CWS)

This option allows the external setting of the Chilled Water Setpoint, independent of the Front Panel Chilled Water Setpoint, by one of three means:

1. A remote resistor/potentiometer input (fixed or adjustable)
2. An isolated voltage input 2-10 VDC
3. An isolated current loop input 4-20 mA

To enable external setpoint operation, "External Chilled Water Setpoint" (Operator Settings Menu) should be set to "E" using the Clear Language Display.

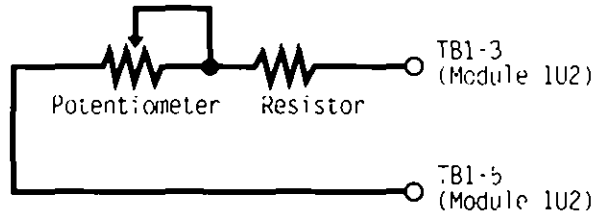
### 1. Remote Resistor/Potentiometer Input (fixed or adjustable)

Connect the remote resistor and/or potentiometer to terminals TB1-3 and TB1-5 of Options Module 1U2, as shown in Figure 16

For units with 40 F to 60 F LCWS range, a field-furnished 25 Kohm linear taper potentiometer ( $\pm 10\%$ ) and a fixed 5.6 Kohm ( $\pm 10\%$ ) 1/4 Watt resistor should be used

For units with 20 F to 39 F LCWS range, a field-furnished 25 Kohm linear taper potentiometer ( $\pm 10\%$ ) and a fixed 15 Kohm ( $\pm 10\%$ ) 1/4 Watt resistor should be used.

**Figure 16**  
**Resistor and Potentiometer**  
**Arrangement for External Chilled**  
**Water Setpoint**





If the potentiometer is to be remotely mounted, it and the resistor must be connected to the UCM prior to mounting. Then, with the Clear Language Display showing "Active Chilled Water Setpoint" (Chiller Report Menu), the Clear Language Display can be used to calibrate the positions of the potentiometer to correspond with the desired settings for the leaving water temperature. External resistor input values for various chilled water setpoints are shown in Table 6.

### 2. Isolated 2-10 VDC Voltage Source Input

Set DIP Switch SW1-1 of Options Module 1U2 to "OFF". Connect the voltage source to terminals TB1-4 (+) and TB1-5 (-) on Options Module 1U2. CWS is now based on the following equation:

$$\text{CW Setpoint } ^\circ\text{F} = (\text{VDC} \times 8.125) - 16.25$$

Sample values for CWS vs. VDC signals are shown in Table 6

- Minimum setpoint = 0 F (2.0 VDC input)
- Maximum setpoint = 65 F (9.4 VDC input)
- Maximum = 15 VDC
- continuous input voltage
- Input impedance = 40.1 Kohms (SW1-1 on)

### 3. Isolated 4-20 mA Current Source Input

Set DIP Switch SW1-1 of Options Module 1U2 to "ON". Connect the current source to terminals TB1-4 (+) and TB1-5 (-). CWS is now based on the following equation:

$$\text{Setpoint } ^\circ\text{F} = (\text{mA} \times 4.0625) - 16.25$$

Sample values for CWS vs. mA signals are shown in Table 6.

- Minimum setpoint = 0 F (4.0 mA)
- Maximum setpoint = 65 F (18.8 mA)
- Maximum = 30 mA
- continuous input current
- Input impedance = 499 ohms (SW1-1 on)

**Note:** The negative terminal TB1-5 is referenced to the UCM chassis ground. To assure correct operation, 2-10 VDC or 4-20 mA signals must be isolated or "floating" with respect to the UCM chassis ground. See Figure 11.

**Table 6**  
**Input Values Vs. External Chilled Water Setpoint**

Resistance (Ohms)	Inputs		Resulting Chilled Water Setpoint (F)
	Current (ma)	Voltage (Vdc)	
94433	4.0	2.0	0.0
68609	5.2	2.6	5.0
52946	6.5	3.2	10.0
42434	7.7	3.9	15.0
34889	8.9	4.5	20.0
29212	10.2	5.1	25.0
24785	11.4	5.7	30.0
21236	12.6	6.3	35.0
18327	13.8	6.9	40.0
15900	15.1	7.6	45.0
13844	16.3	8.2	50.0
12080	17.5	8.8	55.0
10549	18.8	9.4	60.0
9050	20.0	10.0	65.0

### External Current Limit Setpoint (CLS)

This option allows the external setting of the Current Limit Setpoint, independent of the Front Panel Current Limit Setpoint, by one of three means.

1. A remote resistor/potentiometer input (fixed or adjustable)
2. An isolated voltage input 2-10 VDC
3. An isolated current loop input 4-20 mA

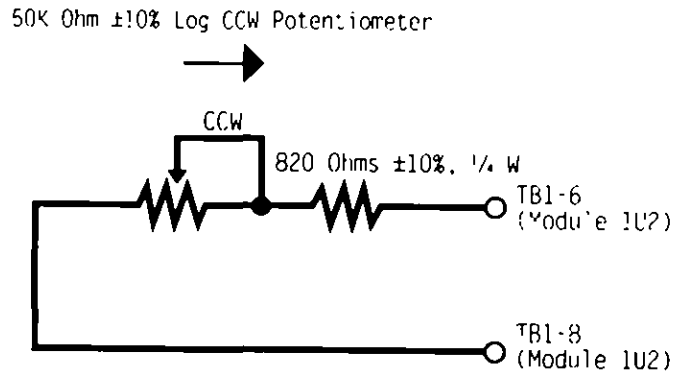
To enable external Current Limit Setpoint operation, "External Current Limit Setpoint" (Operator Settings Menu), should be set to "E" using the Clear Language Display.

1. Remote Resistor/Potentiometer Input

To cover the entire range of Current Limit Setpoints (40 to 120%), a field furnished 50 Kohm log taper potentiometer ( $\pm 10\%$ ) and a fixed 820 ohm ( $\pm 10\%$ ) 1/4 Watt resistor should be wired in series and connected to terminals TB1-6 and TB1-8 of options module 1U2, as shown in Figure 17.

If the potentiometer is to be remotely mounted, it and the resistor must be connected to the UCM prior to mounting. Then, with the Clear Language Display showing "Active Current Limit Setpoint" (Chiller Report Menu), the Clear Language Display can be used to calibrate the positions of the potentiometer to correspond with the desired settings for the current limits. External resistor input values for various current limit setpoints are shown in Table 7

**Figure 17**  
Resistor and Potentiometer Arrangement for External Current Limit Setpoint



**Table 7**  
Input Values Vs. External Current Limit Setpoint

Resistance (Ohms)	Inputs		Resulting Current Limit Setpoint (%RLA)
	Current (ma)	Voltage (Vdc)	
49000	4.0	2.0	40
29000	5.0	3.0	50
19000	8.0	4.0	60
13000	10.0	5.0	70
9000	12.0	6.0	80
6143	14.0	7.0	90
4010	16.0	8.0	100
2333	18.0	9.0	110
1000	20.0	10.0	120

## 2. 2-10 VDC Voltage Source Input

Set DIP Switch SW1-2 of Options Module 1U2 to "OFF". Connect the voltage source to terminals TB1-7 (+) and TB1-8 (-) of Options Module 1U2. CLS is now based on the following equation:

$$\text{CL Setpoint \%} = (\text{VDC} \times 10) + 20$$

Sample values for CLS vs. VDC signals are shown in Table 7.

Minimum setpoint = 40% (2.0 VDC input)  
Maximum setpoint = 120% (10.0 VDC input)  
Maximum = 15 VDC  
continuous input  
voltage  
Input impedance = 40.1 Kohms  
(SW1-2 off)

## 3. 4-20 mA Current Source Input

Set DIP Switch SW1-2 of Options Module 1U2 to "ON". Connect the current source to terminals TB1-7 (+) and TB1-8 (-) of Options Module 1U2. CLS is now based on the following equation:

$$\text{CL Setpoint \%} = (\text{mA} \times 5) + 20$$

Sample values for CLS vs. mA signals are shown in Table 7.

Minimum setpoint = 40% (4.0 mA)  
Maximum setpoint = 120% (20.0 mA)  
Maximum = 30 mA  
continuous input  
current  
Input impedance = 499 ohms  
(SW1-2 off)

**Note:** The negative terminal TB1-8 is referenced to the UCM chassis ground. To assure correct operation, 2-10 VDC or 4-20 mA signals must be isolated or "floating" with respect to the UCM chassis ground. See Figure 11.

## Optional Bidirectional Communications Link (BCL)

This option allows the Clear Language Display in the control panel to exchange information (eg. operating setpoints and Auto/Standby commands) with a higher level control device, such as a Tracer, a multiple-machine controller or a remote display panel. A shielded, twisted-pair connection establishes the bidirectional communications link between the unit control panel and the Tracer, multiple-machine controller or remote display panel.

**Note:** The shielded, twisted-pair conductors must run in a separate conduit.

**Caution: To prevent control malfunctions, do not run low voltage wiring (<30 V) in conduit with conductors carrying more than 30 volts.**

### General

Field wiring for the communication link must meet the following requirements:

1. All wiring must be in accordance with the NEC and local codes.
2. Communication link wiring must be shielded, twisted-pair wiring (Belden 8760, or equivalent). See Figure 11 for wire size.
3. The maximum total wire length for each communication link is 5,000 feet.
4. The communication link cannot pass between buildings.
5. All UCM's on the communication link can be connected in a "daisy chain" configuration.

## Communication Link Connection Procedure

1. Refer to the Tracer installation literature to determine proper communication link termination connections at the Tracer unit.
2. Refer to the Remote Clear Language Display installation procedure in this manual.
3. Connect the shield of the communication link wiring to the designated shield terminal at the Tracer unit.
4. Connect leads 561 and 562 from the proper terminals of 1U2TB2 on the UCM to the Tracer, as shown in Figure 11. There is no polarity requirement for this connection.
5. At the UCM, the shield should be cut and taped to prevent any contact between the shield and ground. See Figure 11.  
**Note:** On multiple-unit installations, splice the shielding of the two twisted-pairs that come into each UCM in the "daisy chain" system. Tape the spliced connections to prevent any contact between the shield and ground. At the last UCM in the chain, the shield should be cut and taped off.
6. For unit ICS address selection, see ICS Address (Service Settings Menu).

---

## Remote Clear Language Display Installation Procedure

The Remote CLD is intended for indoor use and is not weatherproof. It is mounted in a molded-plastic display box with a molded rubber keypad. Although this is not the same as the membrane keypad of the unit's CLD, the key locations and labels are identical.

### General

**Caution: To prevent control malfunctions, do not run low voltage wiring (30 volts or less) in conduit with circuits of greater than 30 volts.**

Field wiring for the communication link must meet the following requirements:

1. All wiring must be in accordance with NEC and all local codes.
2. Communication link wiring must be 14 AWG shielded, twisted pair wire (Belden 8760, or equivalent).
3. The communication link must not exceed 5,000 feet for each link.
4. The communication link must not pass between buildings.

### Remote CLD Mounting

All mounting hardware (tools, screws, etc.) is to be field supplied. Figure 18 shows the mounting holes in the back of the Remote CLD panel. Also shown are the electrical access knockouts at the bottom and top of the panel. Remove the knockouts that will be used for wire entry, prior to mounting the panel.

**Note:** On the back of the panel is a knockout for an electrical outlet box, if one is to be used.

Prior to mounting the panel, the actual microprocessing board needs to be carefully removed and set aside. To remove the board, open the protective door that covers the keypad. Remove the cover plate at the bottom of the keypad, by loosening the screw on the cover plate.

After removing the cover plate, remove the four screws that secure the keypad (one in each corner). The keypad can now be lifted out of the display box.

Attach the display box to the mounting surface with screws through the mounting hole and two mounting slots, shown in Figure 19.

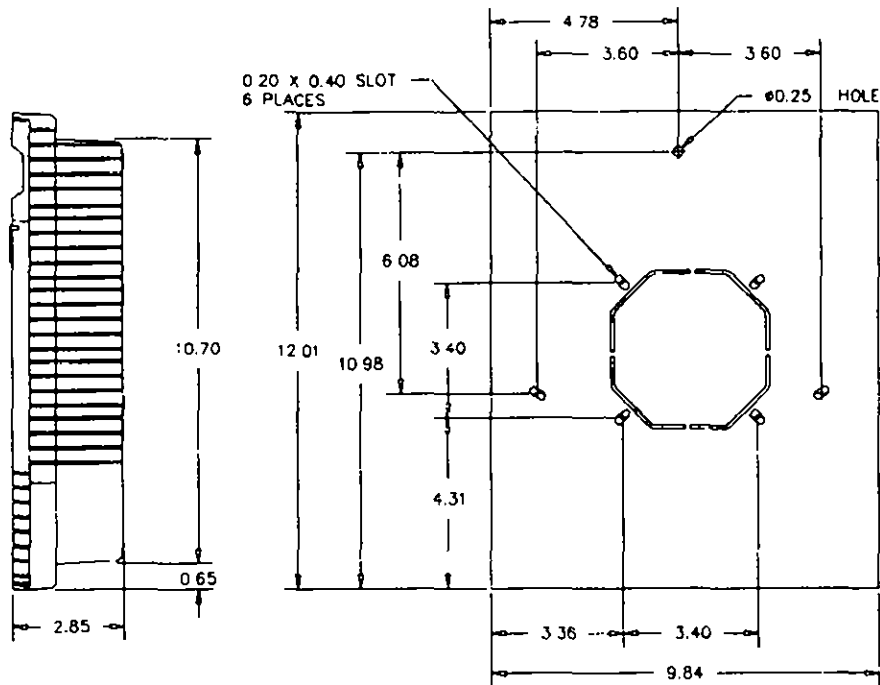
**Note:** If an electrical box is to be used, attach the display box with screws through the four mounting slots around the knockout.

The top of the display box is marked "TOP". Note the position of the box before mounting it to the surface. With the box in the desired position against the mounting surface, mark the location of the mounting holes.

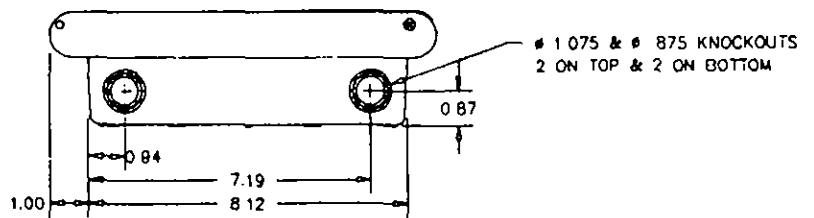
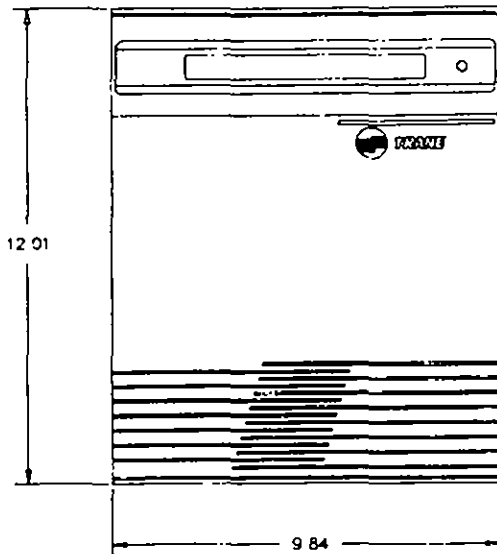
Remove the box and drill the necessary holes in the surface. Put the display box back in position and secure it to the mounting with the required screws.

The microprocessing board can now be replaced in the display box with its four attaching screws.

**Figure 18**  
**Remote CLD Panel**  
**Mounting Holes and**  
**Electrical Access Knockouts**



**MOUNTING PATTERN**  
**FRONT VIEW**



**X13650416**

## Remote CLD Panel Wiring

The Remote CLD requires a 24 volt power source and a shielded, twisted-pair wire between the panel and the Clear Language Display. See Figure 19.

**WARNING: To prevent injury or death, disconnect the electrical power source before completing connections to the unit.**

As shown in Figure 20, the wire runs from terminals J3A-1(+) and J3A-2(-) in the unit's buffer module (1U7) to terminals J1(+) and J1(-) in the Remote CLD. Be sure that one lead is connected to the (+) terminal at each end and the other lead is connected to the (-) terminal at each end.

For units #2, #3 and #4 wire similarly as shown in Figure 20.

Do not run the shielded, twisted-pair wire in a conduit that also contains circuits of greater than 30 volts. Attach the shield to

a grounding lug in the unit's control panel. Cut and tape the shield at the Remote CLD panel, as shown in Figure 19

Connect the 24 volt power supply to terminals J2A and J2B in the Remote CLD panel. The polarity of the power source is not a concern, but the power source must be grounded to terminal J2Gnd.

**Note:** A field-supplied Class 2, 24 VAC, 40 VA transformer can be used as a power supply for the Remote CLD panel.

**Note:** Both a Remote CLD and a Tracer unit can be connected to the UCM.

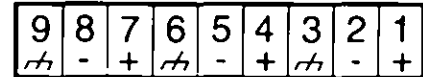
## ICS Address Setting

The setting of the ICS address for the Remote CLD is not necessary

## Multiple Unit Operation

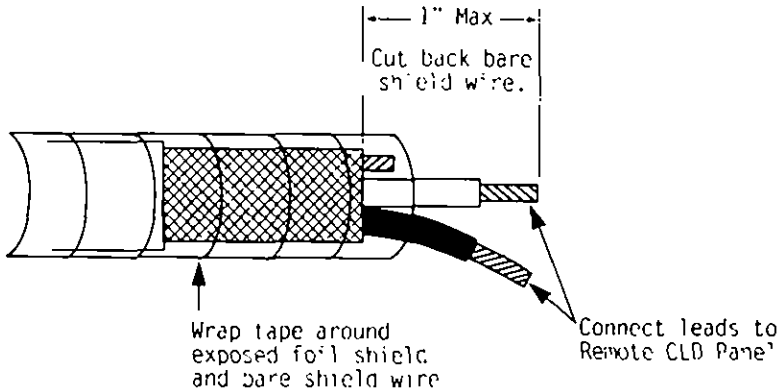
In a multiple unit configuration, the Remote CLD Panel has the capability to communicate with up to four units. Each unit requires a separate communication link with the Remote CLD panel.

Terminal strip TB4 is used to wire in the second, third and fourth units to the Remote CLD. TB4 is labeled as shown below:

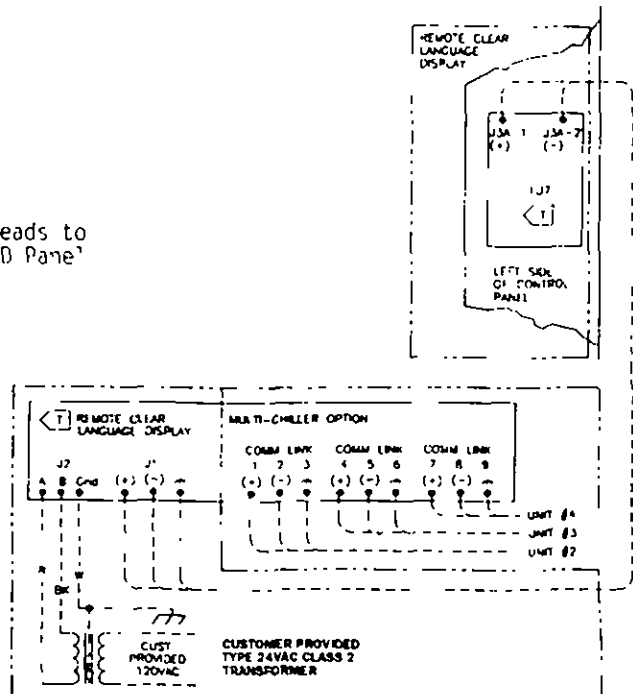


Terminals 1-3 are for the second unit  
Terminals 4-6 are for the third unit.  
Terminals 7-9 are for the fourth unit.

**Figure 19**  
Shielded, Twisted Pair Communication Link at the Remote CLD Panel



**Figure 20**  
Remote Display Panel Interconnecting Wiring



---

## Installation Check List

Complete this checklist as the unit is installed, to verify that all recommended procedures are accomplished **before** the unit is started. **This checklist does not replace the detailed instructions given in the "Installation - Mechanical" and "Installation - Electrical" sections of this manual.** Read both sections completely, to become familiar with the installation procedures, prior to beginning the work.

### Receiving

- Verify that the unit nameplate data corresponds to the ordering information.
- Inspect the unit for shipping damage and any shortages of materials. Report any damage or shortage to the carrier.

### Unit Location and Mounting

- Inspect the location desired for installation and verify adequate service access clearances.
- Provide drainage for evaporator water.
- Remove and discard all shipping materials (cartons, etc.)
- Install optional spring or neoprene isolators, *if required*.
- Level the unit and secure it to the mounting surface.

### Unit Piping

- Flush all unit water piping before making final connections to the unit.

**Caution: If using an acidic commercial flushing solution, construct a temporary bypass around the unit to prevent damage to internal components of the evaporator.**

**Caution: To avoid possible equipment damage, do not use untreated or improperly treated system water.**

- Connect the chilled water piping to the evaporator.
- Install pressure gauges and shutoff valves on the chilled water inlet and outlet to the evaporator.
- Install a pipe strainer in the entering chilled water line.
- Install a balancing valve and flow switch (discretionary) in the leaving chilled water line.
- Install a drain with shutoff valve or a drain plug on the evaporator
- Vent the chilled water system at high points in the system piping.
- Apply heat tape and insulation, as necessary, to protect all exposed piping from freeze-up.

---

## Electrical Wiring

---

**WARNING: To prevent injury or death, disconnect electrical power source before completing wiring connections to the unit.**

---

**Caution: To avoid corrosion and overheating at terminal connections, use copper conductors only.**

- [ ] Connect the unit power supply wiring with fused-disconnect to the terminal block (or unit-mounted disconnect) in the power section of the control panel.
- [ ] Connect the control power supply wiring with fuse disconnect to the terminal strip in the power section of the control panel
- [ ] Connect power supply wiring to the evaporator heat tape. Connect leads 551 and 552 to terminals 14 and 15 of terminal strip 1TB3
- [ ] Connect power supply wiring to the chilled water pump.
- [ ] Connect power supply wiring to any auxiliary heat tapes.
- [ ] Check Interlock Wiring, including External Auto/Stop (terminals 1U1TB3-3 and -4), UCM Pump Control Contacts (terminals 1U1TB4-8 and -9) and Proof of Chilled Water Flow Interlock (terminals 1U1TB3-1 and -2).

**Caution: Information in Inter-connecting Wiring: Chilled Water Pump Interlock and External Auto/Stop must be adhered to or equipment damage may occur.**

- [ ] If the remote running/alarm indicator contacts are used, install leads 525 thru 531 (maximum capacity) from the panel to the proper terminals on terminal strip 1U1, TB4.
- [ ] If the emergency stop function is used, install low voltage leads 513 and 514 to terminals 3 and 4 of 1U1, TB1
- [ ] If indoor zone temperature is to be used, install leads 501 and 502 on 6RT4 to the proper terminals on 1U2, TB1.
- [ ] If the ice making option is used, install leads 501 and 502 on 5K20 to the proper terminals on 1U2, TB1.
- [ ] If Remote CLD Panel is used, install field supplied 24V to panel and interconnect wiring to chiller(s).





# Operating Principles – Mechanical

## General

This section describes the mechanical operating principles of Series R air-cooled chillers equipped with microcomputer-based control systems

The 70 - 125-ton Model RTAA units are dual-compressor, helical-rotary type air-cooled liquid chillers. The basic components of an RTAA unit are

- Clear Language Display
- Unit Control Modules (UCM)
- Unit-mounted panel
- Helical-rotary compressor
- Direct Expansion evaporator
- Air-cooled condenser
- Oil supply system (hydraulic and lubrication)
- Interconnecting piping

Components of a typical RTAA unit are identified in Figures 1 and 2

## Refrigeration (Cooling) Cycle

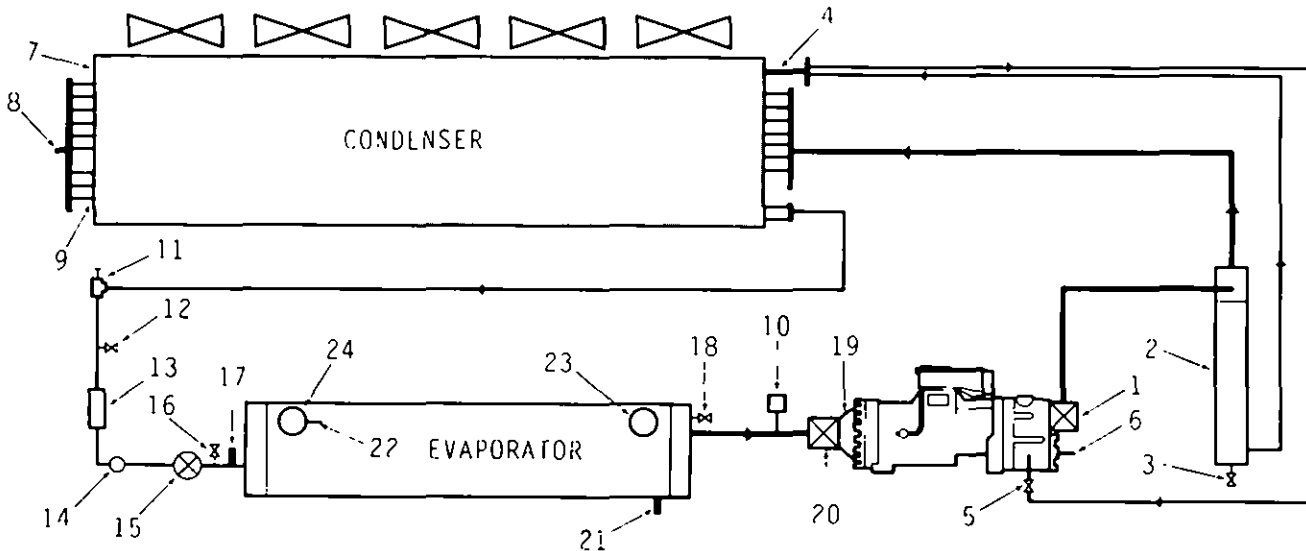
### Cycle Description

Figure 21 represents the refrigeration system and control components. Vaporized refrigerant leaves the evaporator and is drawn into the compressor. Here it is compressed and leaves the compressor as a mixture of hot gas and oil (which was injected during the compression cycle).

The mixture enters the oil separator at the in/out cap. The separated oil flows to the bottom of the separator, while the refrigerant gas flows out the top and passes on to the tubes in the condensing coils. Here circulating air removes heat from the refrigerant and condenses it.

The condensed refrigerant passes through the electronic expansion valve and into the tubes of the evaporator. As the refrigerant vaporizes, it cools the system water that surrounds the tubes in the evaporator.

**Figure 21**  
RTAA Refrigeration System and Control Components



- |   |  |  |
|---|--|--|
| 1. Discharge Service Valve                    | 10. Low Pressure Switch                                | 19. Compressor Suction Rfgt. Temp. Sensor  |
| 2. Oil Separator                              | 11. Liquid Line Service Valve (Backseat Port Upstream) | 20. Suction Service Valve                  |
| 3. 1/4" Angle Valve                           | 12. Schrader Valve                                     | 21. Evaporator Entering Water Temp. Sensor |
| 4. Oil Cooler                                 | 13. Filter/Dryer                                       | 22. Evaporator Leaving Water Temp. Sensor  |
| 5. Quick Connect Shutoff Valve or Angle Valve | 14. Sight Glass  | 23. Entering Water Connection              |
| 6. Oil Temperature Sensor                     | 15. Electronic Expansion Valve                         | 24. Leaving Water Connection               |
| 7. Condenser                                  | 16. 1/4" Angle Valve                                   |  |
| 8. Saturated Condenser Rfgt. Temp. Sensor     | 17. Saturated Evaporator Rfgt. Temp. Sensor            |  |
| 9. Subcooler                                  | 18. Relief Valve                                       |  |

## Compressor Description

The compressors used by the Model RTAA Series "R" Air-cooled chiller consists of two distinct components: the motor and the rotors

### Compressor Motor

A two-pole, hermetic, squirrel-cage induction motor (3600 rpm) directly drives the compressor rotors. The motor is cooled by suction refrigerant gas from the evaporator, entering the end of the motor housing through the suction line.

### Compressor Rotors

The compressor is a semi-hermetic, direct-drive helical rotary type compressor. Each compressor has two rotors - "male" and "female" - which provide compression. See Figure 22. The male rotor is attached to, and driven by, the motor, and the female rotor is, in turn, driven by the male rotor. Separately housed bearing sets are provided at each end of both rotors.

The helical rotary compressor is a positive displacement device. The refrigerant from the evaporator is drawn into the suction opening at the end of the

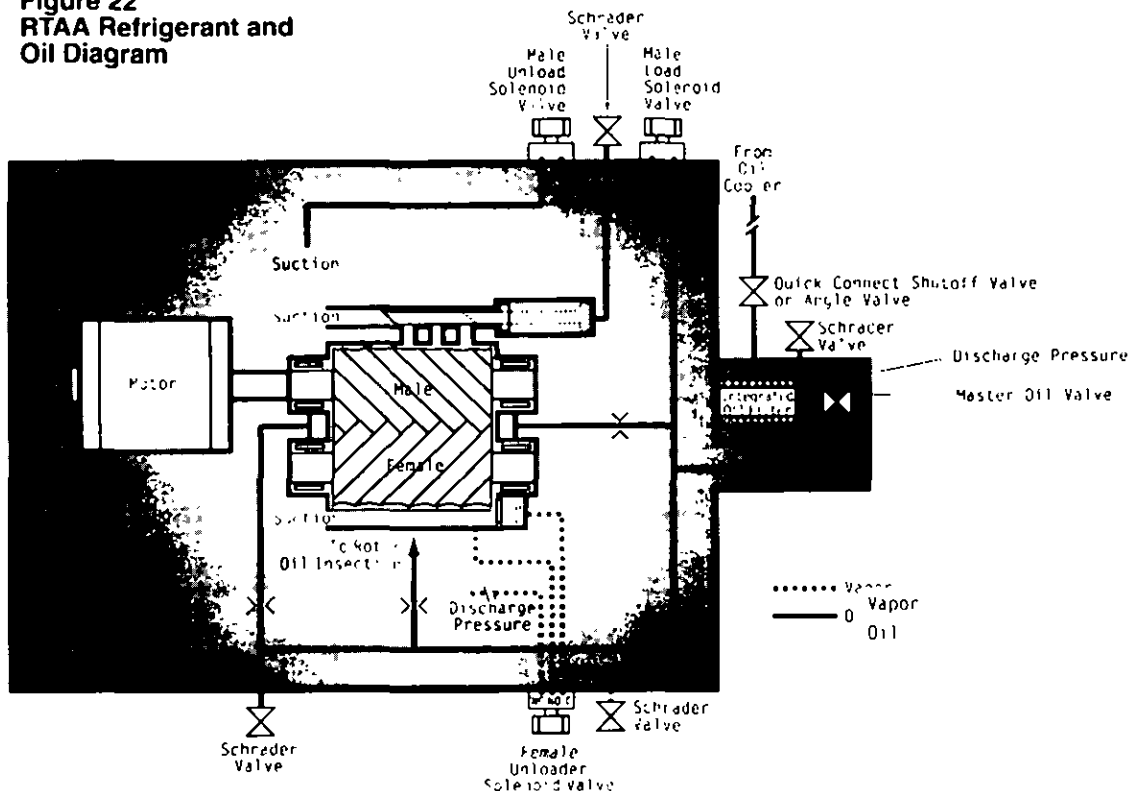
motor barrel, through a suction strainer screen, across the motor, and into the intake of the compressor rotor section. The gas is then compressed and discharged directly into the discharge line

There is no physical contact between the rotors and compressor housing. The rotors contact each other at the point where the driving action between the male and female rotors occurs. Oil is injected along the top of the compressor rotor section, coating both rotors and the compressor housing interior. Although this oil does provide rotor lubrication, its primary purpose is to seal the clearance spaces between the rotors and compressor housing.

A positive seal between these internal parts enhances compressor efficiency by limiting leakage between the high pressure and low pressure cavities.

Capacity control is accomplished by means of two unloader valve assemblies in the rotor section of the compressor. The female rotor valve is a two-position valve and the male valve is an infinitely variable position valve. See Figure 22.

**Figure 22**  
RTAA Refrigerant and Oil Diagram



Compressor load capacity is determined by the positions of the unloader valves. They divert refrigerant gas from the rotors to the compressor suction, thus unloading the compressor. This varies the compressor capacity to match the load and reduces the KW draw of the compressor motor.

The two-position female unloader will fully open or fully close a port on the rotor housing, at the discharge end of the female rotor. This relieves the refrigerant gas to suction and unloads the compressor. The female unloader valve is the first stage of loading after the compressor starts and the last stage of unloading before the compressor shuts down.

The modulating male unloader valve opens or closes ports in the rotor housing along the side of the male rotor. It can move to a more loaded (closed) position after the female unloader valve is in the loaded position or can relieve refrigerant gas to suction to unload the compressor.

### **Compressor Loading Sequence**

When there is a call for chilled water, the UCM will start the compressor which has the least number of starts. If the first compressor cannot satisfy the demand, the UCM will start the other compressor and then balance the load on both compressors by pulsing the load/unload solenoids.

The load on the compressors will be kept in balance, as load fluctuates, until the demand for chilled water is reduced to a level that can be handled by one compressor. At this time, the UCM will drop off the compressor that has the greatest number of operating hours and will adjust the load on the other compressor, as required.

## **Oil System Operation**

### **Overview**

Oil that collects in the bottom of the oil separator is at condensing pressure during compressor operation; therefore, oil is constantly moving to lower pressure areas. Refer to Figure 22.

As the oil leaves the separator, it passes through the oil cooler at the top of the condensing coils. It then goes through the service valve and filter. At this point, some of the oil is used to control the slide valve movement in the compressor, via the male load/unload solenoids. The remaining oil passes through the master oil valve and performs the functions of compressor bearing lubrication and compressor oil injection.

If the compressor stops for any reason, the master oil valve closes, isolating the oil charge in the separator and oil cooler during "off" periods. The master oil valve is a pressure activated valve. Discharge pressure of the rotors, that is developed when the compressor is on, causes the valve to open.

To ensure proper lubrication and minimize refrigerant condensation in the compressor, a heater is mounted on the bottom of the compressor housing. A signal from the UCM energizes this heater during the compressor "Off" cycle to keep refrigerant from condensing in the compressor. The heater element is continuously energized.

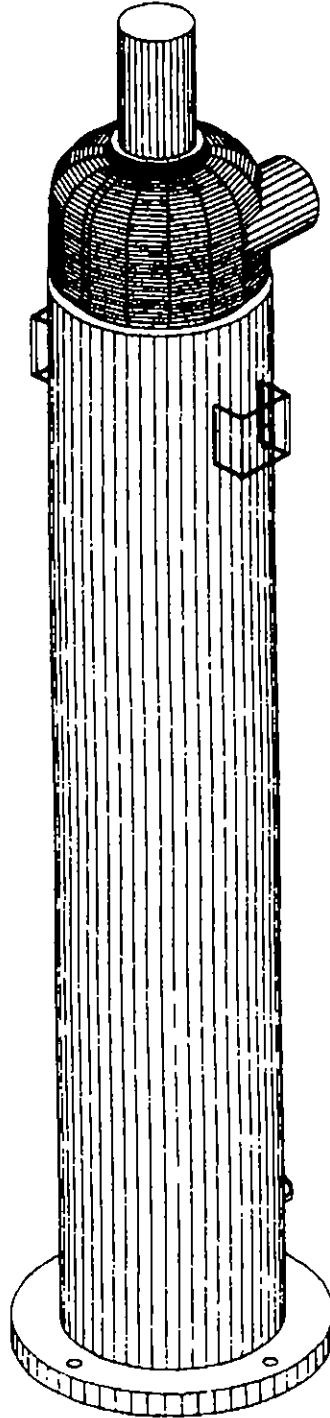
### **Oil Separator**

The oil separator consists of a vertical tube, joined at the top by the refrigerant discharge line from the compressor. As shown in Figure 23, the discharge line is essentially tangential to the tube. This causes the refrigerant to swirl in the tube and throws the oil to the outside, where it collects on the walls and flows to the bottom. The compressed refrigerant vapor, stripped of oil droplets, exits out the top of the oil separator and is discharged into the condensing coils.

The oil separators on chillers with the remote evaporator option incorporate heaters to prevent refrigerant migration when the machine is off.

---

**Figure 23**  
**Oil Separator**



---

### Compressor Bearing Oil Supply

Oil is injected into the bearing housings located at each end of both the male and female rotors. Each bearing housing is vented to compressor suction, so that oil leaving the bearings returns through the compressor rotors to the oil separator.

### Compressor Rotor Oil Supply

Oil flows through this circuit directly from the master oil valve, through the oil filter to the top of the compressor rotor housing. There it is injected along the top of the rotors to seal clearance spaces between the rotors and the compressor housing and to lubricate the rotors.

### Female Unloader Valve

The position of the female unloader valve determines compressor capacity. Its position is dependent on whether the backside of the female unloader valve is exposed to the compressor discharge or suction pressure. See Figure 22.

The female unloader valve solenoid receives a constant signal from the UCM, based on system cooling requirements. To load the compressor, the female unloader valve solenoid is energized and discharge pressure is passed through the normally-closed port and into the cylinder. This pushes the female unloader valve closed.

To unload the compressor, the female unloader valve solenoid is de-energized and the discharge pressure is relieved to the suction of the compressor. The female unloader valve retracts into the cylinder and the compressor is unloaded.

Just prior to a normal compressor shutdown, the male unload valve solenoid is energized and the slide valve moves to the fully-unloaded position, so the unit always starts fully unloaded.

### Oil Filter

Each compressor is equipped with a replaceable-element oil filter. The filter removes any impurities that could foul the solenoid valve orifices and compressor internal oil supply galleries. This also prevents excessive wear of compressor rotor and bearing surfaces. Refer to the maintenance portion of this manual for recommended filter element replacement intervals.

### Condenser Fan Staging

The fans on the RTAA 70-125 Ton units are staged by logic in the UCM. The UCM takes several different pressures and temperatures into account, to determine when fans should be added or subtracted. Input from the outside air temperature sensor, the saturated condensing refrigerant temperature sensor, and the saturated evaporator refrigerant temperature sensor are monitored to determine fan staging.

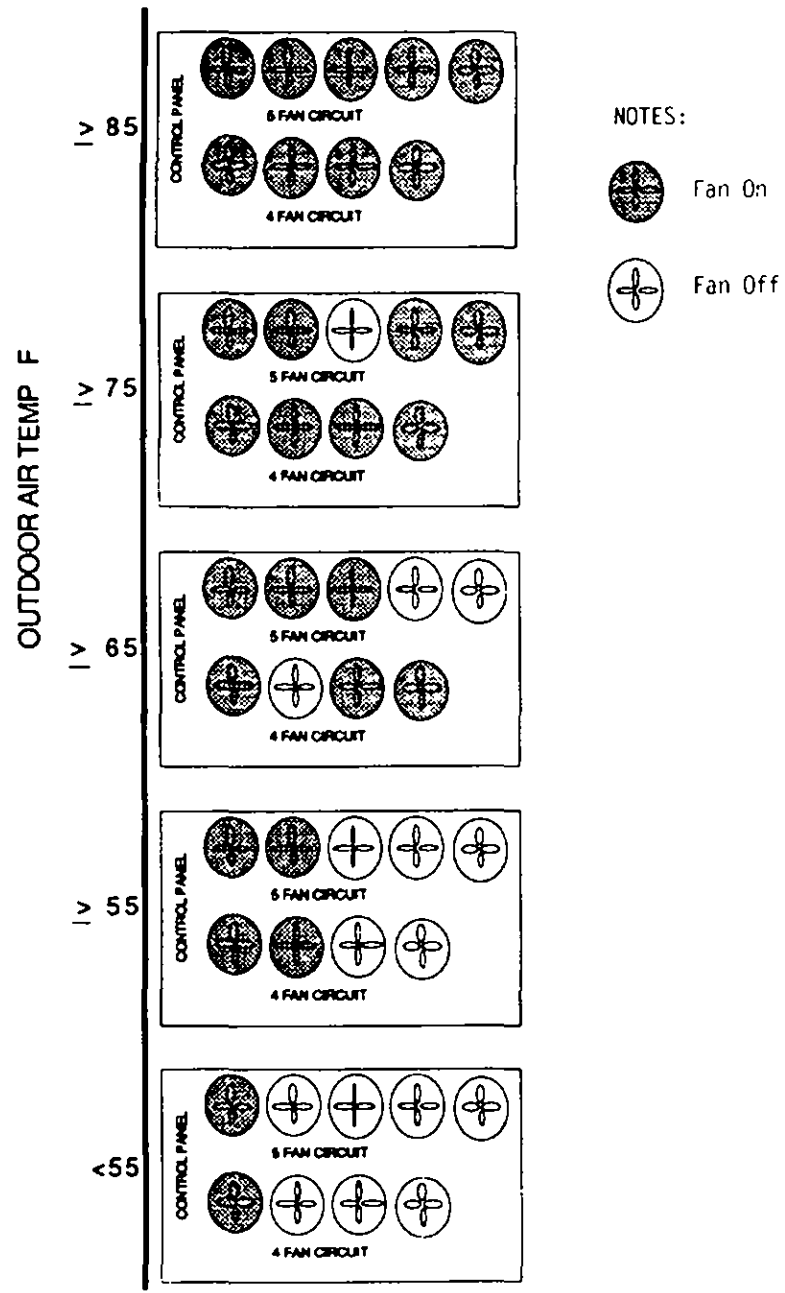
The number of fans activated at startup is dependant upon the outdoor air temperature. Figure 24 shows fan activation at different temperatures.

During normal operation, the micro uses PID control to maintain a  $70 \pm 5$  psid between the condensing pressure and the evaporator pressure. Through the use of algorithm logic, a fan will be added if the pressure differential is greater than 75 psid and the fan inverter is at maximum speed.

A "Low Differential Pressure" diagnostic will take the circuit off-line if the pressure differential falls below 40 psid for more than two minutes.

A "High Differential Pressure" diagnostic will take the circuit off-line if the pressure differential increases to 350 psid or greater. This diagnostic can also be produced if the pressure differential increases to the range between 320 psid and 349 psid. The UCM will allow the unit to remain on-line if there is no increase in pressure for a one hour period. Otherwise, the unit will trip off-line and display the "High Differential Pressure" diagnostic.

**Figure 24**  
**Fan State at Circuit Startup**



# Operating Principles - Adaptive Control™ Microprocessor Logic with Clear Language Display

---

## General

The exclusive Trane Adaptive Control logic with the Clear Language Display is comprised of a system of individual modules located in the control panel. The system consists of six different microprocessor-based components, one of which is the Clear Language Display, as shown in Figure 25. The processors are:

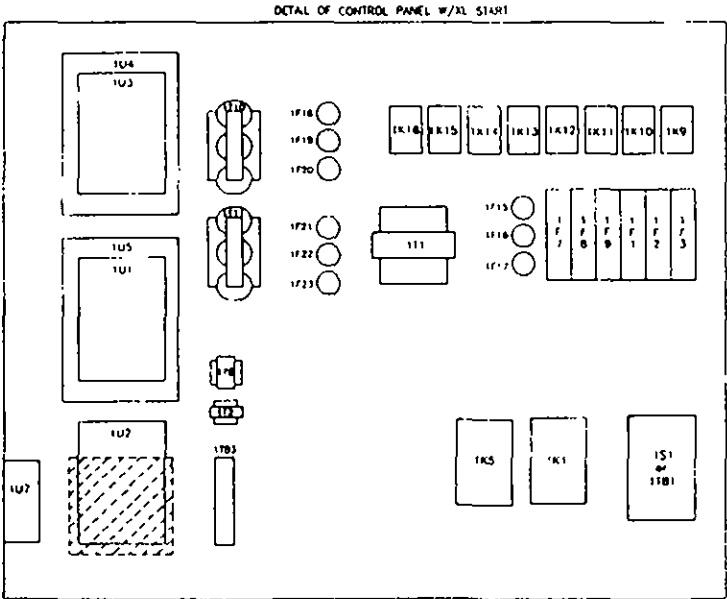
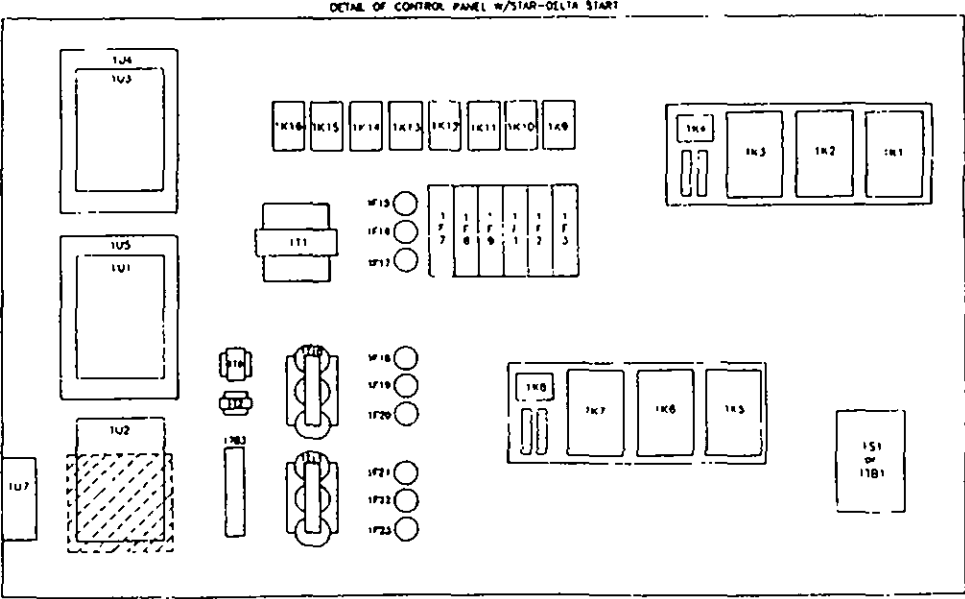
- Clear Language Display - 1U6
- Chiller Module - 1U1
- Communication and Setpoint Reset Option Module - 1U2
- Expansion Valve Module - 1U3
- Compressor Module (one per compressor) - 1U4, 1U5,
- Remote Display Buffer Module - 1U7

The Clear Language Display has various functions that allow the operator to read unit information and adjust setpoints. The following is a list of the available functions.

- Operating and Diagnostic descriptions
- Settings of local setpoints and adjustments
- Actual controlling setpoints
- Specific temperatures
- Specific Pressures
- Enable/Disable status of features and options
- Selection status of SI units or English units
- Under/Over voltage protection
- Display of % line voltage
- Alarm/Running/Maximum Capacity contacts
- Display Starts and Hours



**Figure 25**  
**RTAA Control Panel**



Note: see page 129 for legend.

## Clear Language Display Keypad Overview

### General

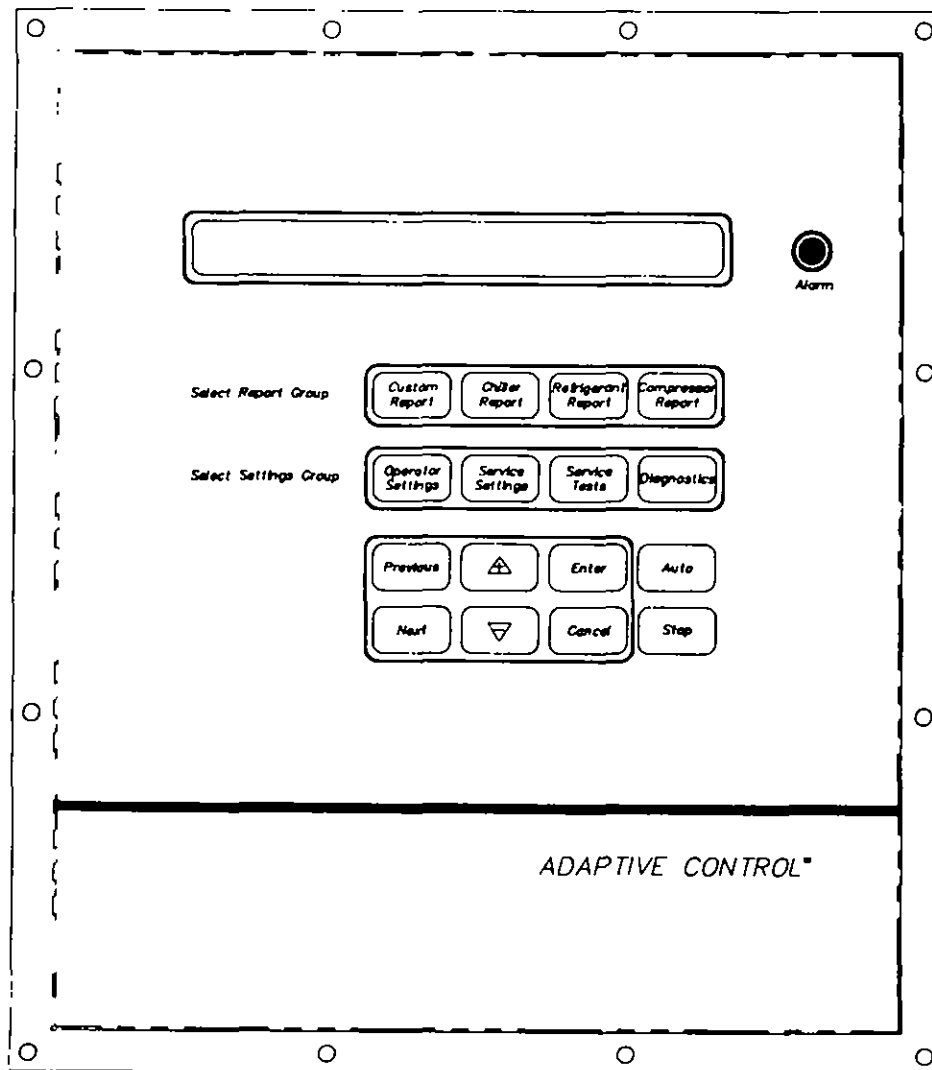
Local operator interface with the system is accomplished using the 16 keys on the front of the Clear Language Display panel. The readout screen is a two line, 40 character liquid crystal with a backlight. The backlight allows the operator to read the display in low-light conditions. The

depression of any key will activate the backlight. The backlight will stay activated for 10 minutes after the last key is pressed. At 10 F or below the backlight will stay activated continuously.

The keys are grouped on the keyboard by the following functions (refer to Figure 26).

- Select Report Group
- Select Settings Group
- Selection Keys
- Stop & Auto Keys

Figure 26  
Operator Interface  
Adaptive Control



## Select Report Group

This group of four keys allows the operator to select and view the following reports:

- Custom Report
- Chiller Report
- Refrigerant Report
- Compressor Report

The Custom Report is the only report of the four that is defined by the operator. Any display under the other three reports can be added to the Custom Report by pressing the plus  $\Delta$  key while the desired read-out is on the display. A maximum of 20 entries can be contained under the Custom Report. Items can be deleted from the Custom Report by pressing the minus  $\nabla$  key when the desired read-out is on the display. The operator must be in the Custom Report menu to delete the desired item.

The Chiller Report, Refrigerant Report and Compressor Report are informational reports that give current status. Each report and its contents are discussed in detail on the following pages.

When any of the four report keys are pressed, the first readout on the display will be the header. The header identifies the title of the report and summarizes the items in the report.

The Next key and Previous key allow the operator to scroll up and down through the display items listed under the report menus. When the last item of a report is displayed and the Next key is pressed, the display will wrap around to the header of the report. When the first item of a report is displayed and the Previous key is pressed, the display will wrap around to the last item.

## Select Settings Group

The first three keys on the second row – Operator Settings, Service Settings and Service Tests – allow the operator to adjust various setpoints and perform various tests. Certain items in these groups are password protected. Refer to the Password section for additional information.

When a setpoint key is pressed, a header will be displayed. The setpoint headers identify the available items and setpoint functions.

The Next and Previous keys function in the same manner as that described in Selected Report Group, above.

Setpoint values are incremented by pressing the plus  $\Delta$  key and decremented by pressing the Minus  $\nabla$  key. Once a setpoint is changed, the Enter key must be pressed to save the new setpoint. If the Cancel key is pressed, the setpoint value on the display will be ignored and the original setpoint will remain.

## Passwords

Passwords are needed to enter into the Service Setup Menu and the Machine Configuration Menu. Both of these menus are accessed through the Service Settings key. If access into these menus is necessary, follow the list of steps below:

1. Press Service Settings
2. Press Next until the readout in the display is:  
Password Required For Further Access  
"Please enter Password"
3. To enter into the Service Setup Menu, press:  
 $\Delta \Delta \nabla \nabla \Delta \Delta$  Enter
4. To enter into the Machine Configuration Menu, press:  
 $\Delta \nabla \Delta \nabla \Delta \nabla$  Enter

Refer to Figure 31 for the list of items found in the Service Setup Menu and Machine Configuration Menu

## Select Report Group and Select Settings Group Flowcharts

Figures 27 thru 32 show the display readouts found under each menu. The first block of the flowchart is the header which is shown on the display after the menu key is pressed. For example:

Press Chiller Report and the readout on the display will be

```
CHILLER RPRT STATUS, WTR TEMPS & SETPTS  
"PRESS (NEXT) (PREVIOUS) TO CONTINUE"
```

Press Next to move down through the Chiller Report. As shown in the figures, the flowchart explains the conditions that the UCM looks at to determine which readout is to be displayed next. For example:

Press Chiller Report to display the header

Press Next to display

```
MODE [OPERATING MODE]  
REQUESTED SETPOINT SOURCE [SETPT SOURCE]
```

Press Next to display

```
COMPRESSOR ON  
CIRCUITS LOCKED OUT
```

Press Next to display

```
ACTIVE ICE TERMINATION SETPOINT  
or  
ACTIVE CHILLED WATER SETPOINT
```

The UCM will determine which screen will be displayed after looking at the current Operating Mode. If the Operating Mode is "Ice Making" or "Ice Making Complete", ACTIVE ICE TERMINATION SETPOINT will be displayed. Otherwise, ACTIVE CHILLED WATER SETPOINT will be shown.

The flowcharts also list the setpoint ranges, default options and a brief description of the item, when necessary. This information is shown in the left-hand column of the page, adjacent to the appropriate display.

---

### Auto/Stop Keys

The chiller will go through a "STOPPING" mode when the Stop key is pressed if a compressor is running. This key has a red background color surrounding it, to distinguish it from the others.

If the chiller is in the Stop mode, pressing the Auto key will cause the UCM to go into the Auto/Local or Auto/Remote mode, depending on the Setpoint Source setting. The Auto key has a green background color.

When either the Auto or Stop key is pressed, Chiller Operating Mode (Chiller Report Menu) will be shown on the display.

### Power Up

When power is first applied to the control panel, the Clear Language Display goes through a self-test. For approximately five seconds, the readout on the display will be

SELF TEST IN PROGRESS

During the self-test, the backlight will not be energized. When the tests are successfully complete, the readout on the display will be

6200 xxxx-xx [TYPE] configuration

Updating Unit Data Please Wait

When updating is successfully completed, the system will default to the first display after the Chiller Report header:

MODE [OPERATING MODE]  
REQUESTED SETPOINT SOURCE [SETPT SOURCE]

and the backlight will be activated.

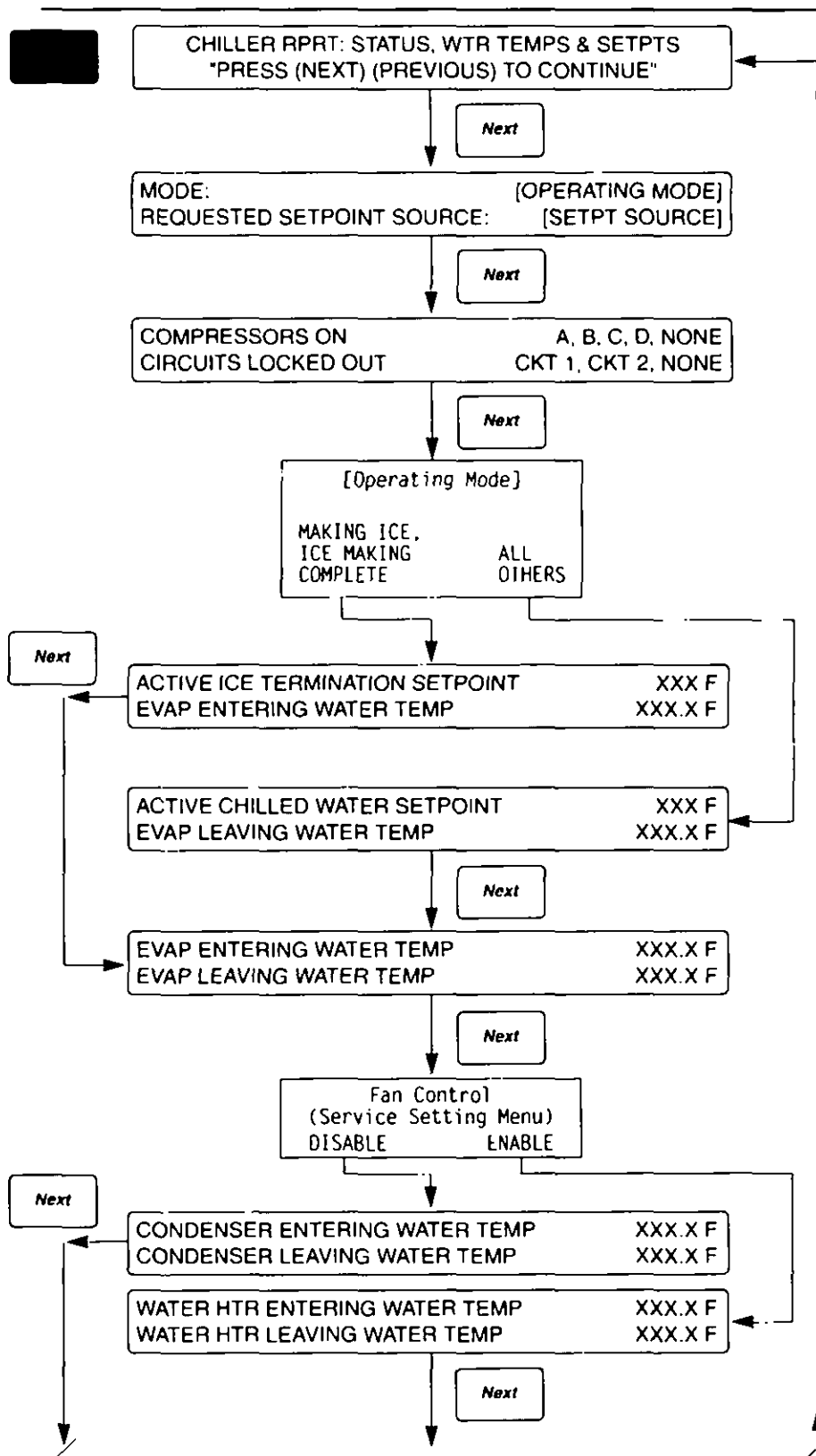
**Figure 27**  
**Chiller Report**

[OPERATING MODE]

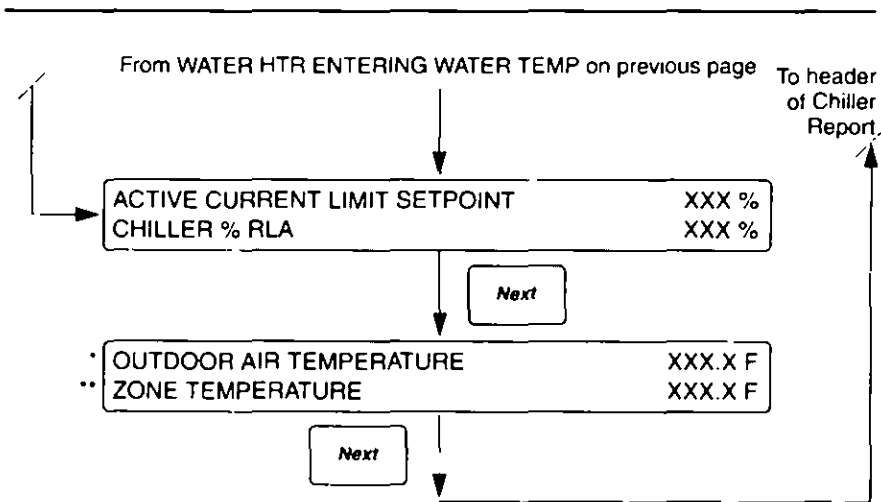
Reset  
 Stopped by Local Display  
 Stopped by Remote Display  
 Stopped by Tracer  
 Stopped by Ext Source  
 Auto  
 Waiting, Restart Inhibit  
 Starting  
 Running  
 Running, Current Limit  
 Running, Condenser Limit  
 Running, Evaporator Limit  
 Stopping  
 Making Ice  
 Ice Making Complete  
 Low Ambient Temp lockout  
 EXV Test  
 Manufacturing Test  
 Service Pumpdown

[SETPT SOURCE]

Local  
 Tracer



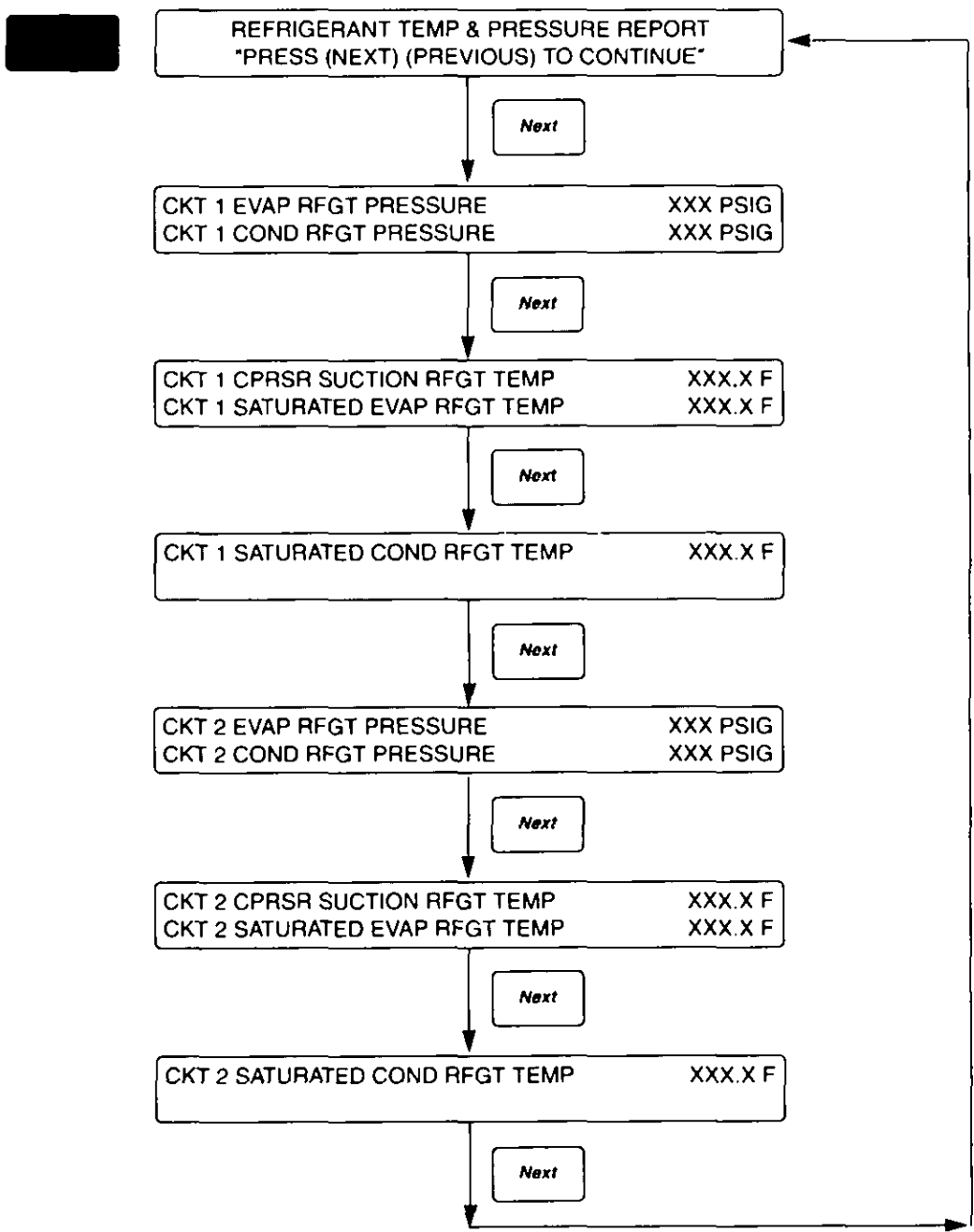
**Figure 27**  
**Chiller Report**  
 (Continued from previous page)



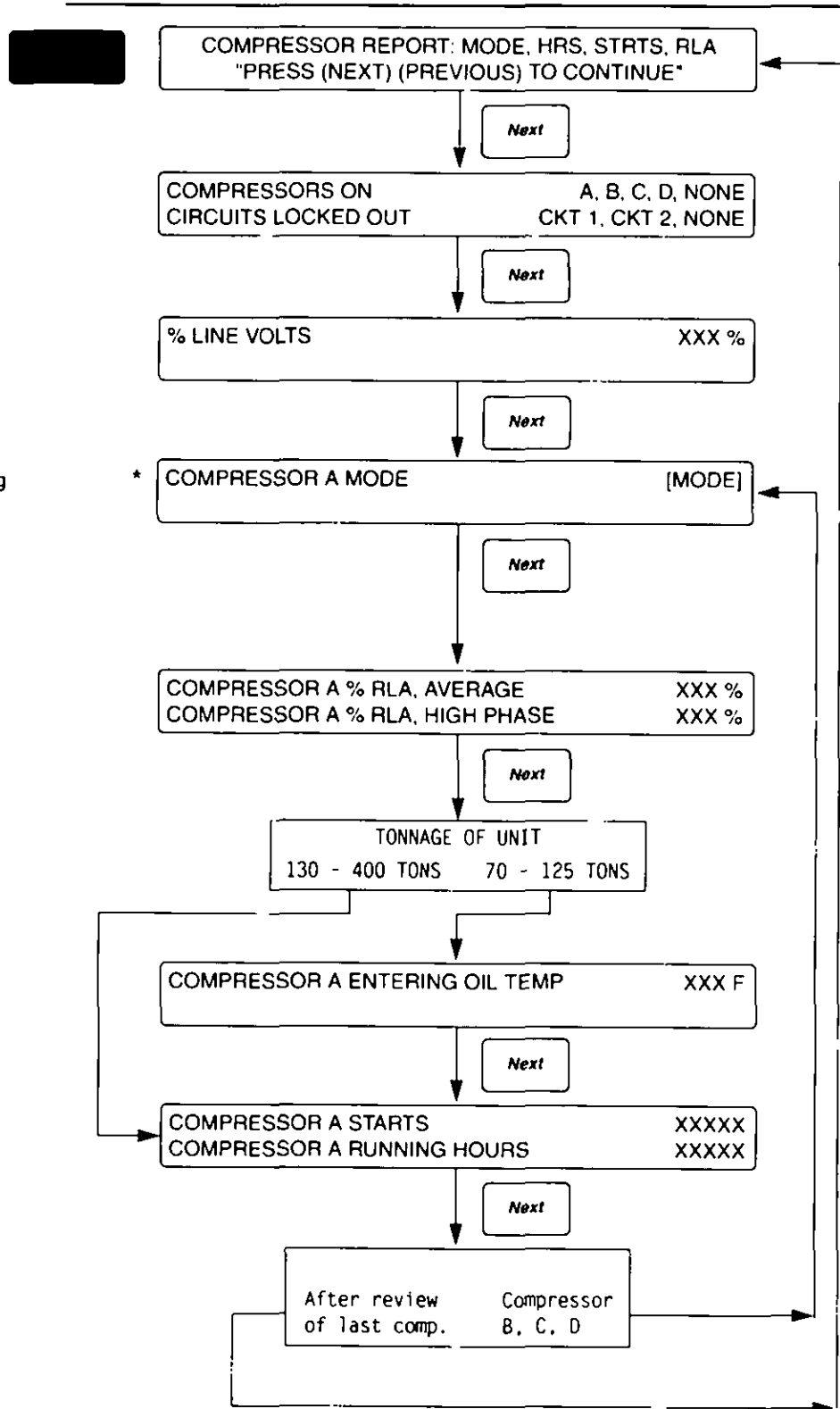
\* Dashes will be displayed if the sensor is open or shorted and neither Outdoor Air Reset or Low Ambient Lockout is enabled.

\*\* Dashes will be displayed if the Zone Temp. Sensor is open or shorted and Zone Reset is not enabled.

Figure 28  
Refrigerant Report



**Figure 29**  
**Compressor Report**



\* Display will change according to comp. reviewing  
 COMPRESSOR A MODE  
 COMPRESSOR B MODE  
 COMPRESSOR C MODE  
 COMPRESSOR D MODE

[MODE]  
 Stopped  
 Locked Out  
 Waiting for Restart Inhibit Time  
 Starting  
 Running  
 Run - Condenser Limit  
 Run - Evaporator Limit  
 Run - Current Limit  
 Stopping  
 Service Pumpdown

REFRIGERANT REPORT  
 COMPRESSOR REPORT



**Figure 30**  
**Operator Settings**

**OPERATOR SETTINGS**

[SOURCE] -  
Local  
Tracer

Default - 44F  
Select - 0F to 65F

\*If "LIMITED by Cutout Setpt.  
(+) to change" is displayed,  
refer to the section on "Leaving  
Water Temperature Cutout" and  
"Low Refrigerant Temperature  
Cutout".

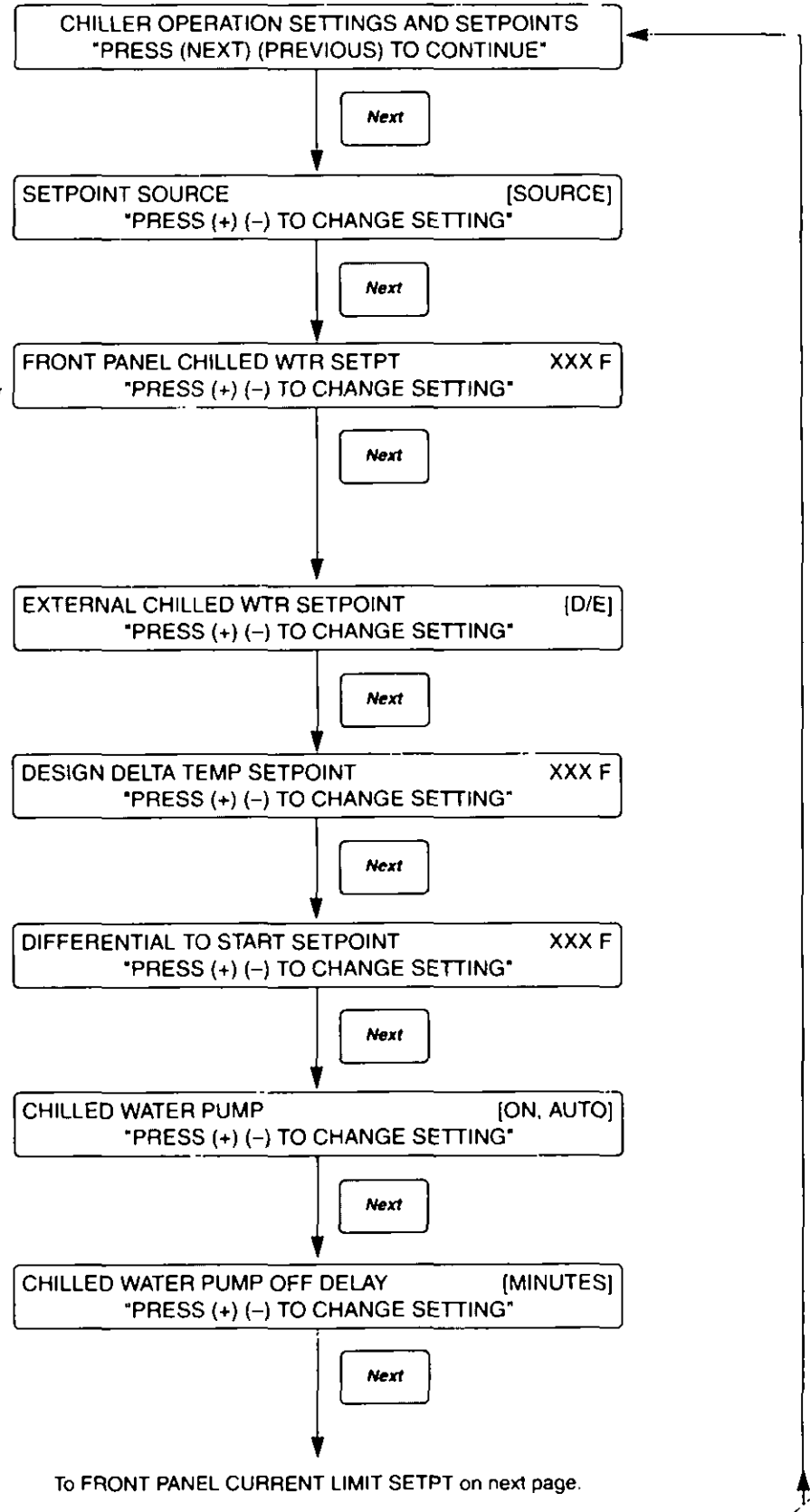
Default - Disable

Default - 10F  
Select - 4F to 30F

Default - 2F  
Select - 2F to 30F

ON = Manual override of Chilled  
Water Pump Off Delay

[MINUTES]  
Default - 10 Min  
Select - 1 Min to 30 Min



**Figure 30**  
**Operator Settings**  
**(Continued from previous page)**

Default = 120%  
 Select = 40% to 120%

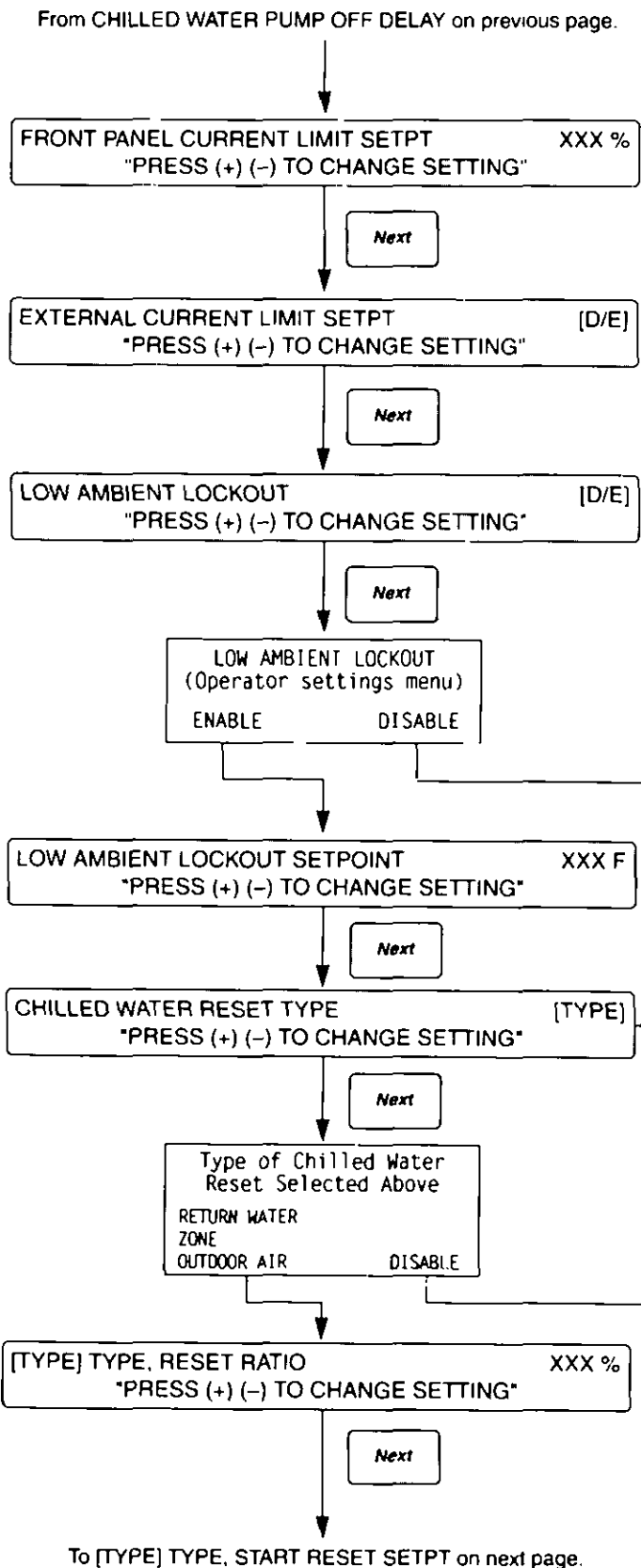
Default = Disable

Default = Disable

Default = 20F  
 Select = -20F to 60F

Default = Disable  
 Select = Return Wtr  
 Zone  
 Outdoor Air

[TYPE]  
 Return:  
 Default = 50%  
 Range = 10% to 120%  
 Zone:  
 Default = 100%  
 Range = 50% to 300%  
 Outdoor:  
 Default = 10%  
 Range = -80% to 80%



OPERATOR SETTINGS

**Figure 30**  
**Operator Settings**  
 (Continued from previous page)

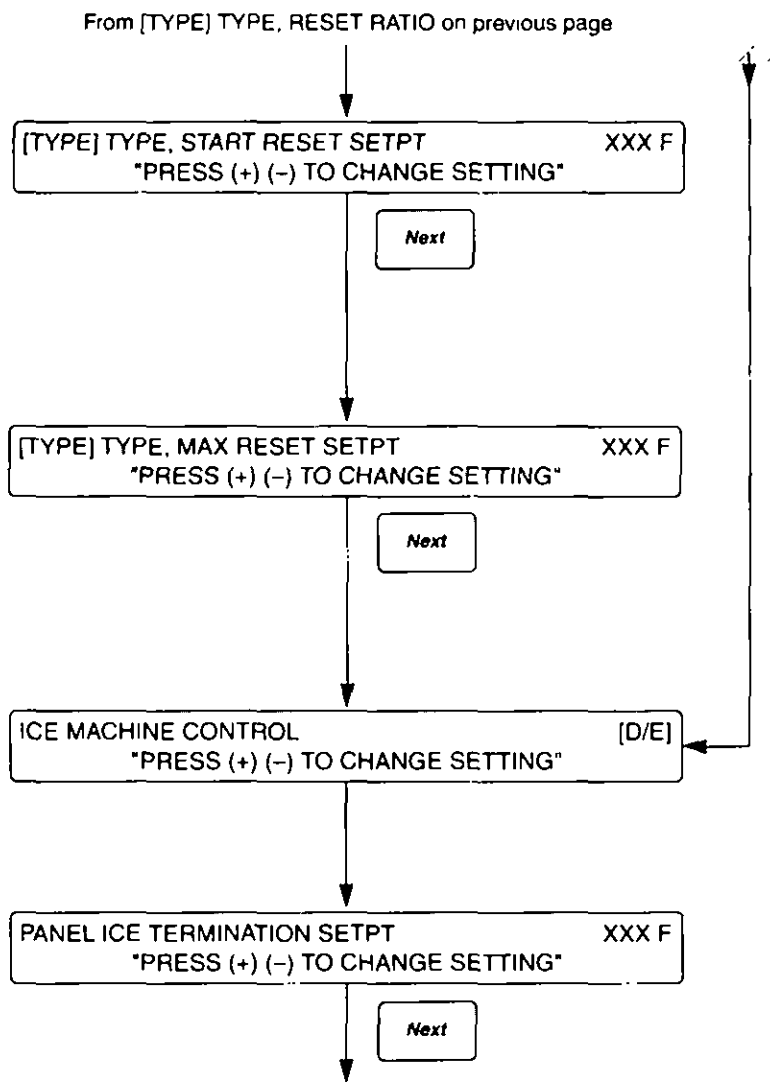
[TYPE]  
 Return:  
   Default = 10F  
   Range = 4F to 30F  
 Zone:  
   Default = 78F  
   Range = 55F to 85F  
 Outdoor:  
   Default = 90F  
   Range = 50F to 130F

[TYPE]  
 Return:  
   Default = 5F  
   Range = 0F to 20F  
 Zone:  
   Default = 5F  
   Range = 0F to 20F  
 Outdoor:  
   Default = 5F  
   Range = 0F to 20F

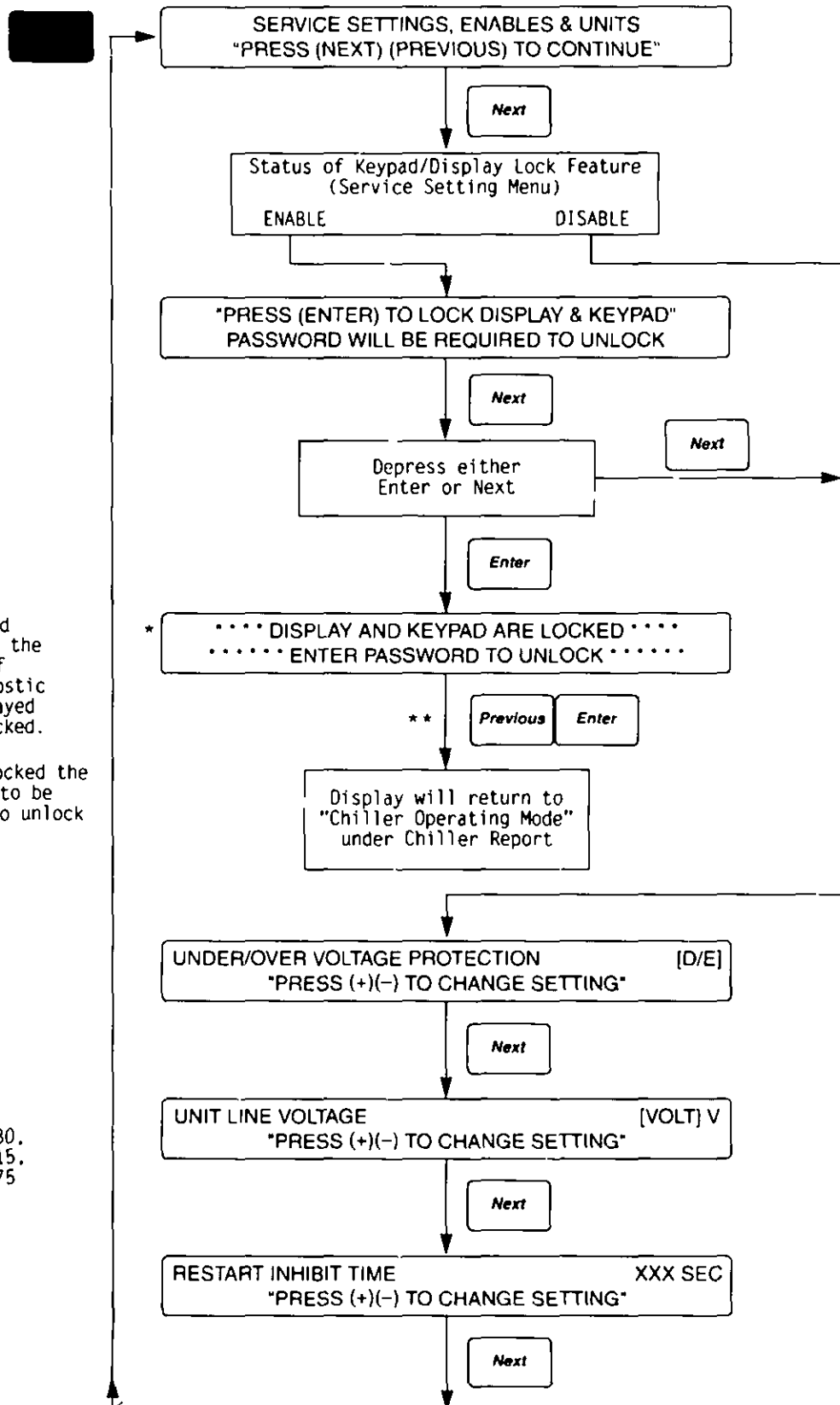
Default = Disable

Default = 27F  
 Select = 20F to 31F

**OPERATOR SETTINGS**  
**SERVICE SETTINGS**



**Figure 31**  
**Service Settings**



\* If the keypad is locked and a diagnostic occurs, the alarm light will flash if applicable but the diagnostic screen will not be displayed until the keypad is unlocked.

\*\* Once the keypad is locked the Previous and Enter need to be pressed simultaneously to unlock the keypad.

Default = Disable

Default = 460  
 Selections = 200, 220, 230,  
 346, 380, 415,  
 460, 500, 575

Default = 120 sec.  
 Select = 30 to 120 sec.

OPERATOR SETTINGS  
SERVICE SETTINGS

To BALANCED CPRSR STARTS & HOURS on next page.

**Figure 31**  
**Service Settings**  
 (Continued from previous page)

Default = Disable

[UNITS]  
 SI  
 ENGLISH

[LANGUAGE]  
 English  
 Francais  
 Espanol  
 Nippon  
 Italiano  
 Deutsch  
 Nederlands

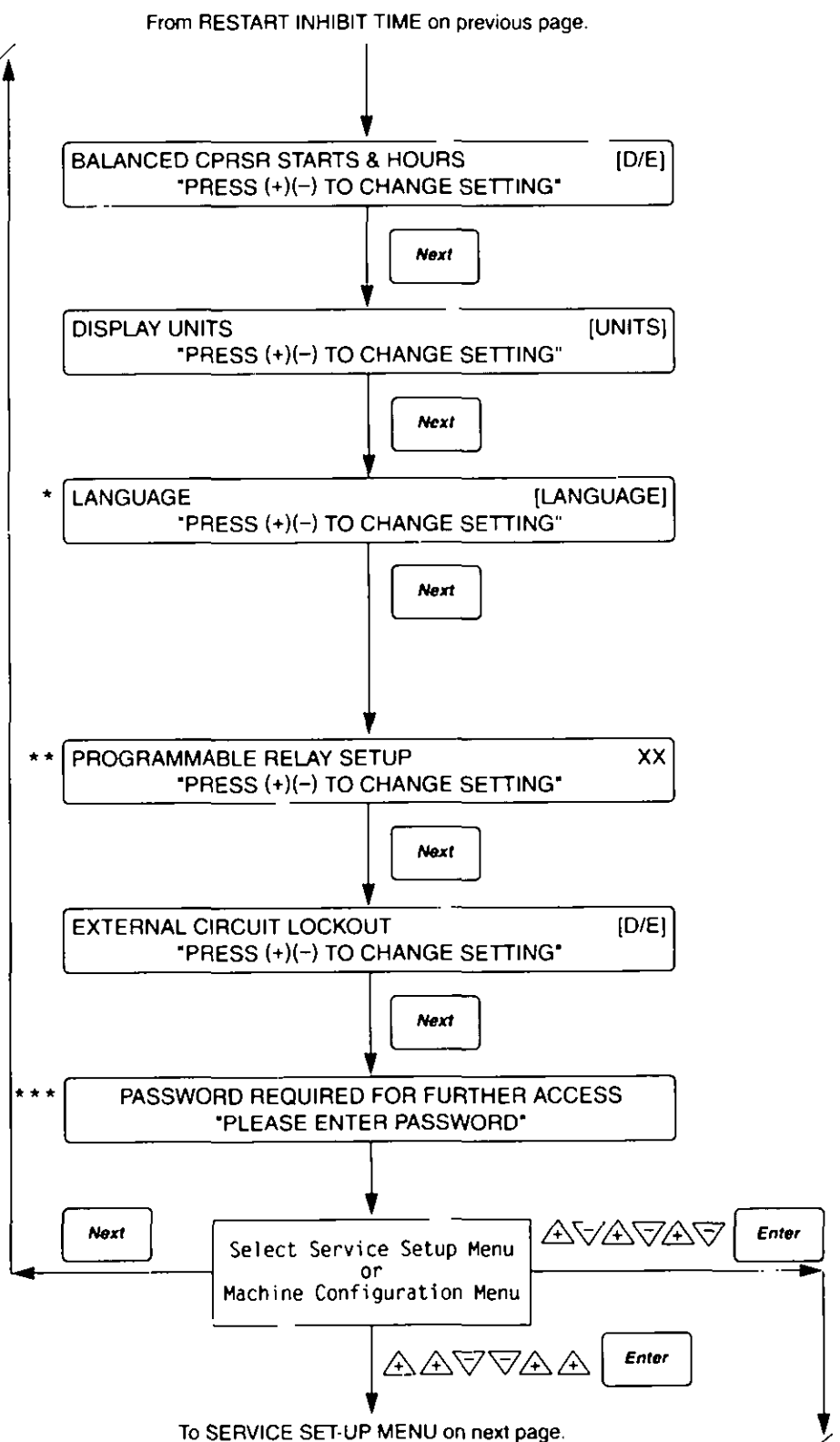
\* Menu item will not be displayed until later version

Default = 1  
 Select = 1 to 12

\*\* Refer to "Alarm, Running, Max. Capacity Outputs" for details.

Default = Disable

\*\*\* Refer to section on "Passwords" for details.



**SERVICE SETTINGS**  
**SERVICE SETUP**

**Figure 31**  
**Service Settings**  
 (Continued from previous page)

Default - 55  
 Select - 0 to 64

Default - 35F  
 Select - -10F to 35F

\* See section on "Leaving Water Temperature Cutout" for proper settings.

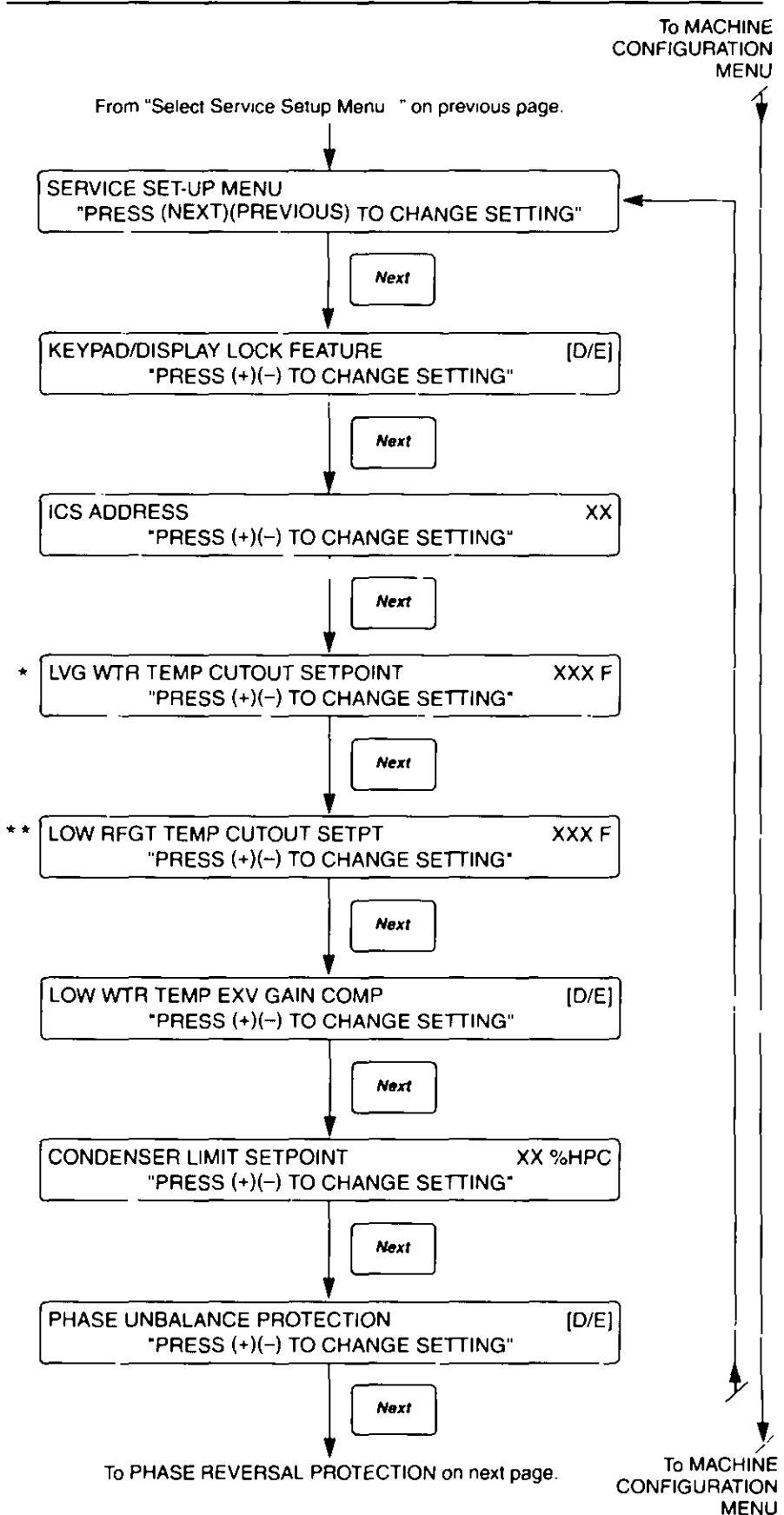
Default - 22F  
 Select - -39F to 35F

\*\* See section on "Low Refrigerant Temperature Cutout" for proper settings

Default - Disable

Default - 90%  
 Select - 80% to 120%

Default - Enable



SERVICE SETTINGS

SERVICE SETUP

**Figure 31**  
**Service Settings**  
 (Continued from previous page)

Default - Enable

Default - 8F  
 Select - 4F to 20F

\* 70 - 125 ton units must be set  
 at 4°F.

Default - 20  
 Select - 2 to 200  
 Increase to make more responsive,  
 decrease to make less responsive.

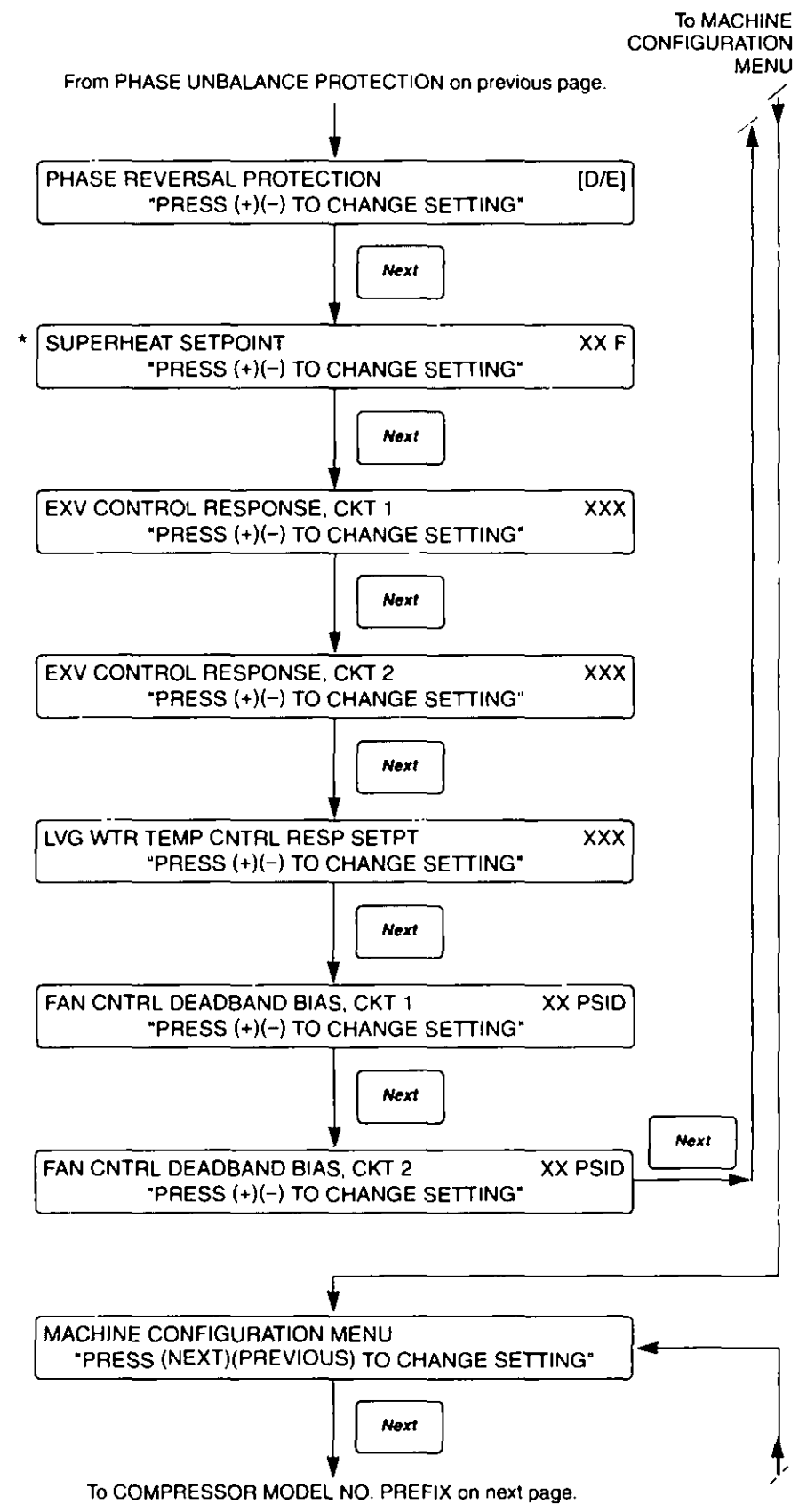
Default - 20  
 Select - 2 to 200  
 Increase to make more responsive,  
 decrease to make less responsive.

Default - 40  
 Select - 2 to 200  
 Increase to make more responsive,  
 decrease to make less responsive.

Default - 0  
 Select - -50 to 50

Default - 0  
 Select - -50 to 50

SERVICE SETTINGS  
 SERVICE SETUP  
 MACHINE CONFIGURATION



**Figure 31**  
**Service Settings**  
 (Continued from previous page)

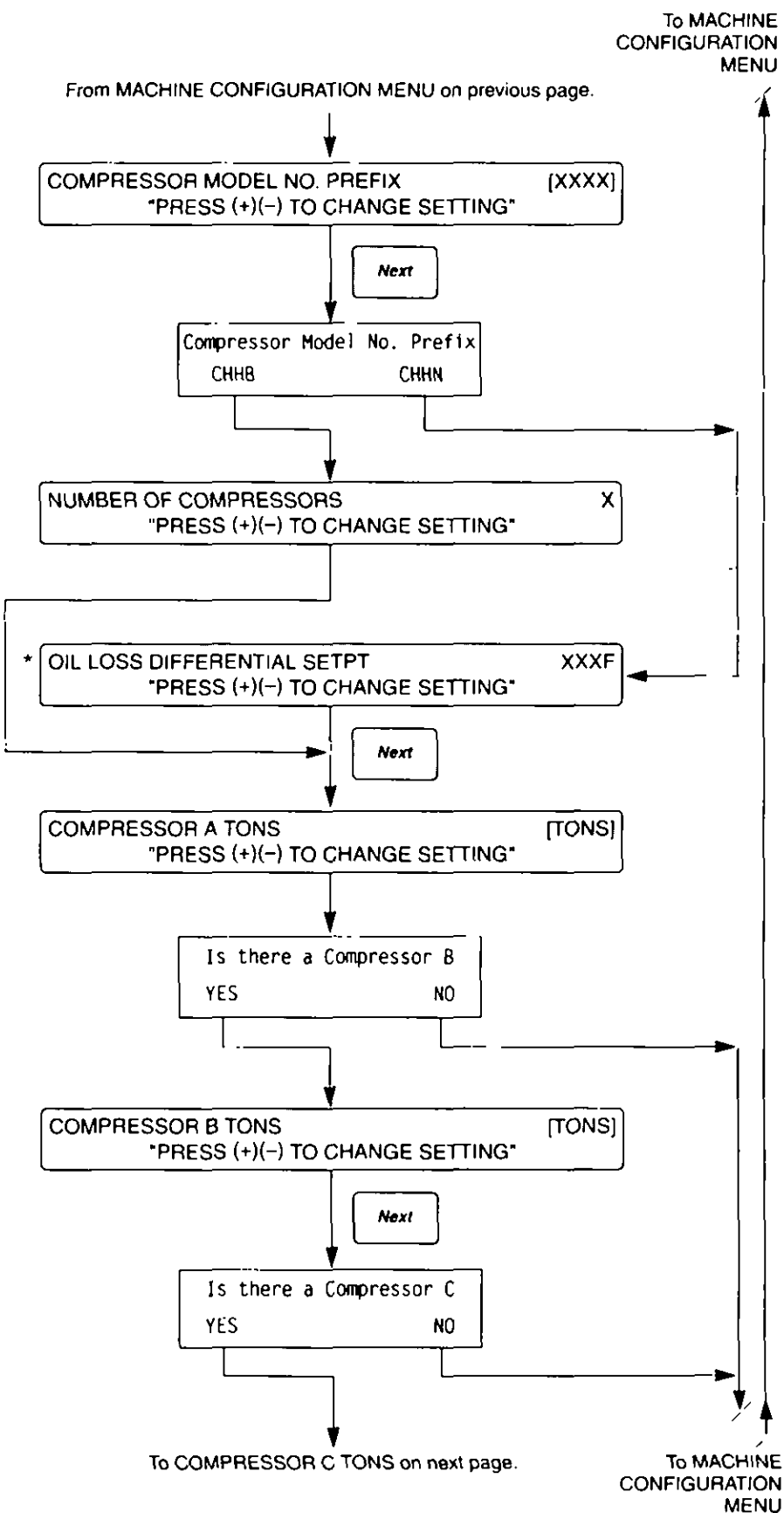
[XXXX]  
 CHHN (70 - 125 ton units)  
 CHHB (130 - 400 ton units)  
 (Refer to Compressor Nameplate)

CPM Default - Enable

Default - -4  
 \* Must be set at -4

Default - 100  
 Select - 30, 35, 40,  
 50, 60, 70,  
 85, 100

Default - 100  
 Select - 30, 35, 40,  
 50, 60, 70,  
 85, 100



SERVICE SETTINGS  
 SERVICE SETUP  
 MACHINE CONFIGURATION



**Figure 31**  
**Service Settings**  
 (Continued from previous page)

Default = 100  
 Select = 30, 35, 40,  
 50, 60, 70,  
 85, 100

Default = 100  
 Select = 30, 35, 40,  
 50, 60, 70,  
 85, 100

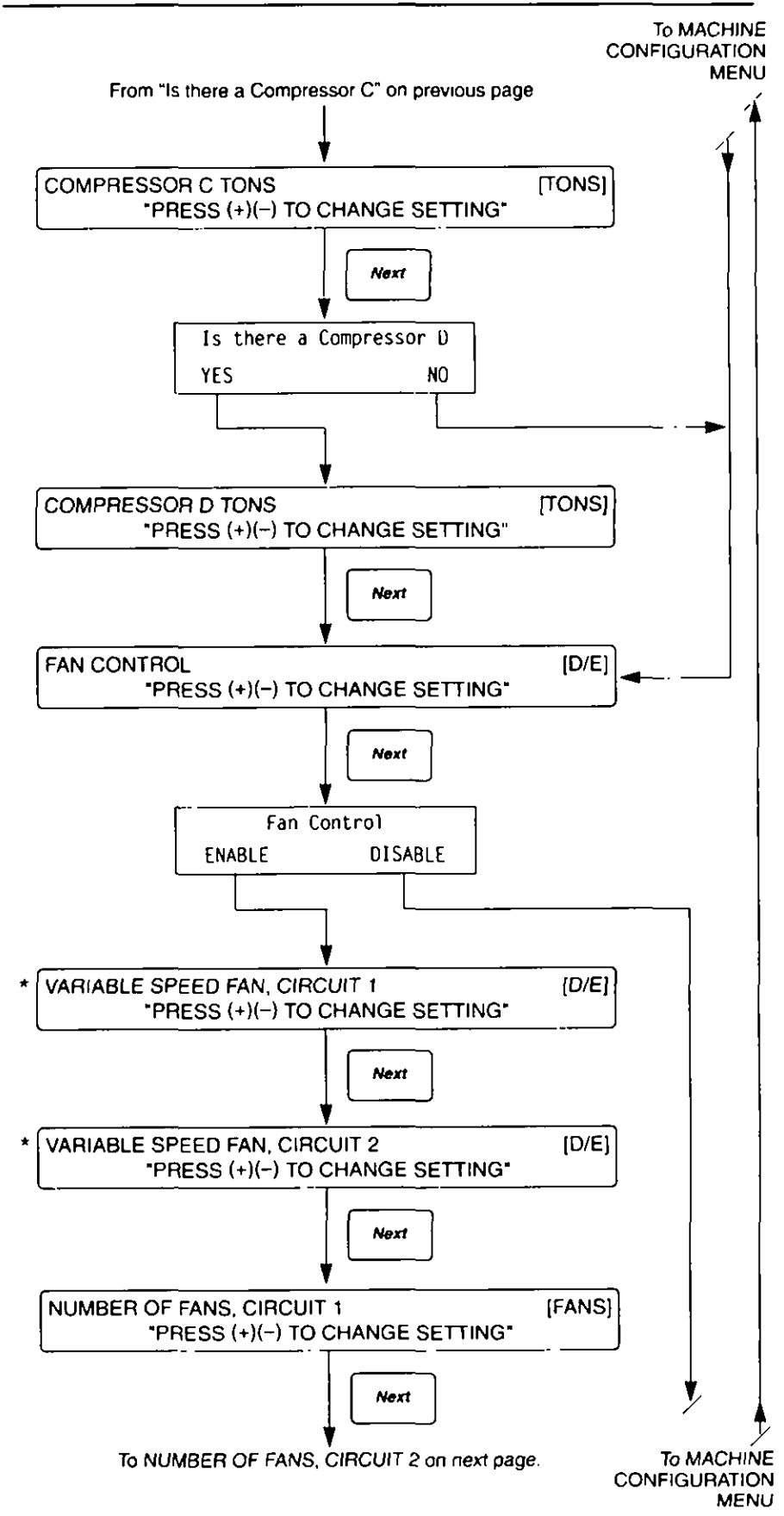
Default = Enable

Default = Disable  
 \* If Variable Speed Fan is set to Enable for either Circuit 1 or Circuit 2, then "Low Ambient Unit, Half Air Flow Fan" and "Low Ambient Unit, Two Speed Motor" are forced to Disable.  
 Default = Disable

Default = 7  
 Select = 4, 5, 6, 7, 8,  
 10, 12, 14

SERVICE SETTINGS

MACHINE CONFIGURATION



**Figure 31**  
**Service Settings**  
**(Continued from previous page)**

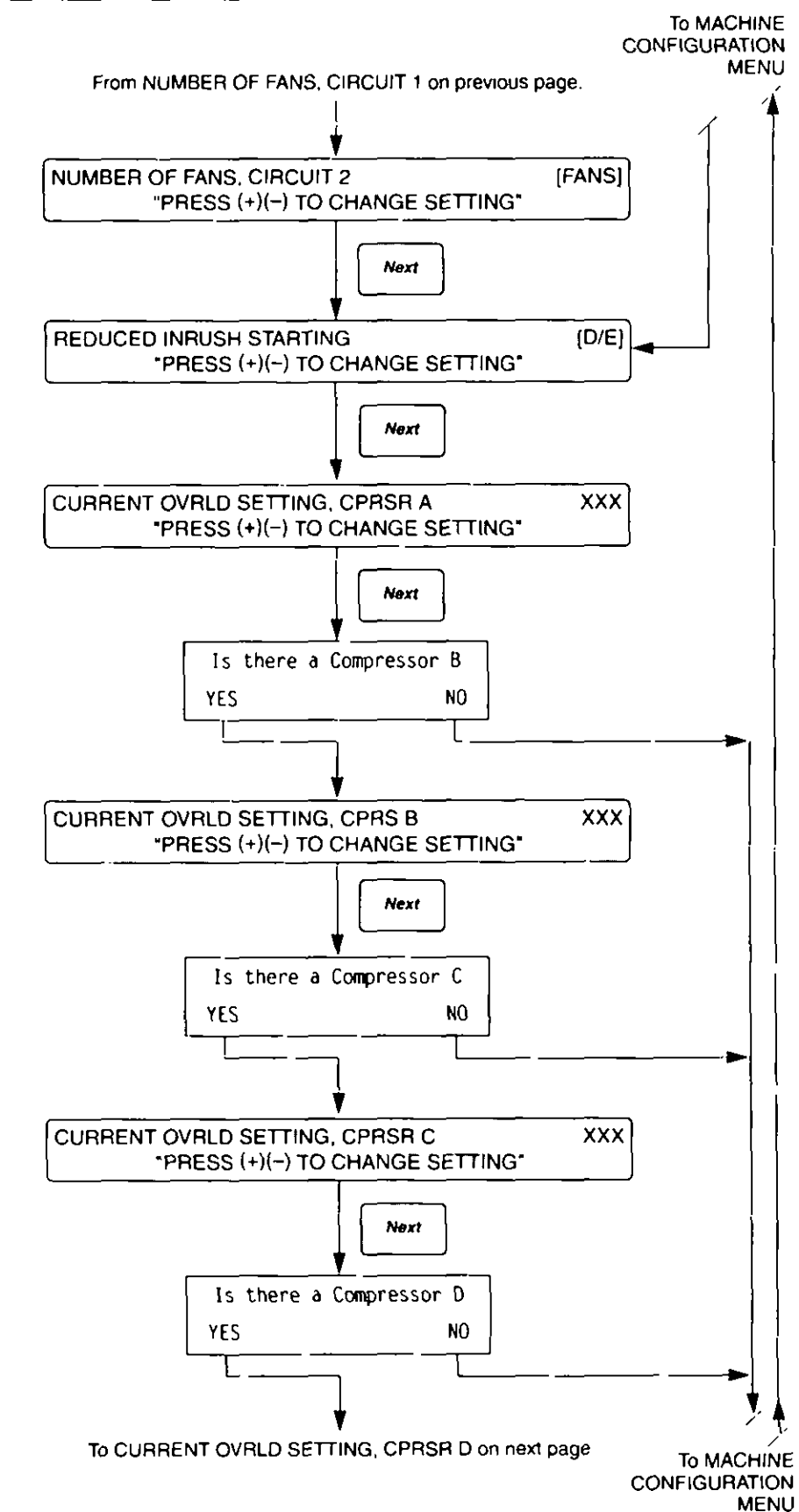
Default - /  
 Select - 4, 5, 6, 7, 8,  
 10, 12, 14

Default - Disable

Default - 00  
 Select - 00 to 31

Default - 00  
 Select - 00 to 31

Default - 00  
 Select - 00 to 31



SERVICE SETTINGS

MACHINE CONFIGURATION

**Figure 31**  
**Service Settings**  
 (Continued from previous page)

Default - 00  
 Select - 00 to 31

Default - Disable  
 \* 70 - 125 tons need "Low Amb  
 Unit, Half Airflow Fan" disabled

Default - Disable  
 \*\* Not applicable to domestic  
 70 - 400 ton unit

Default - Disable

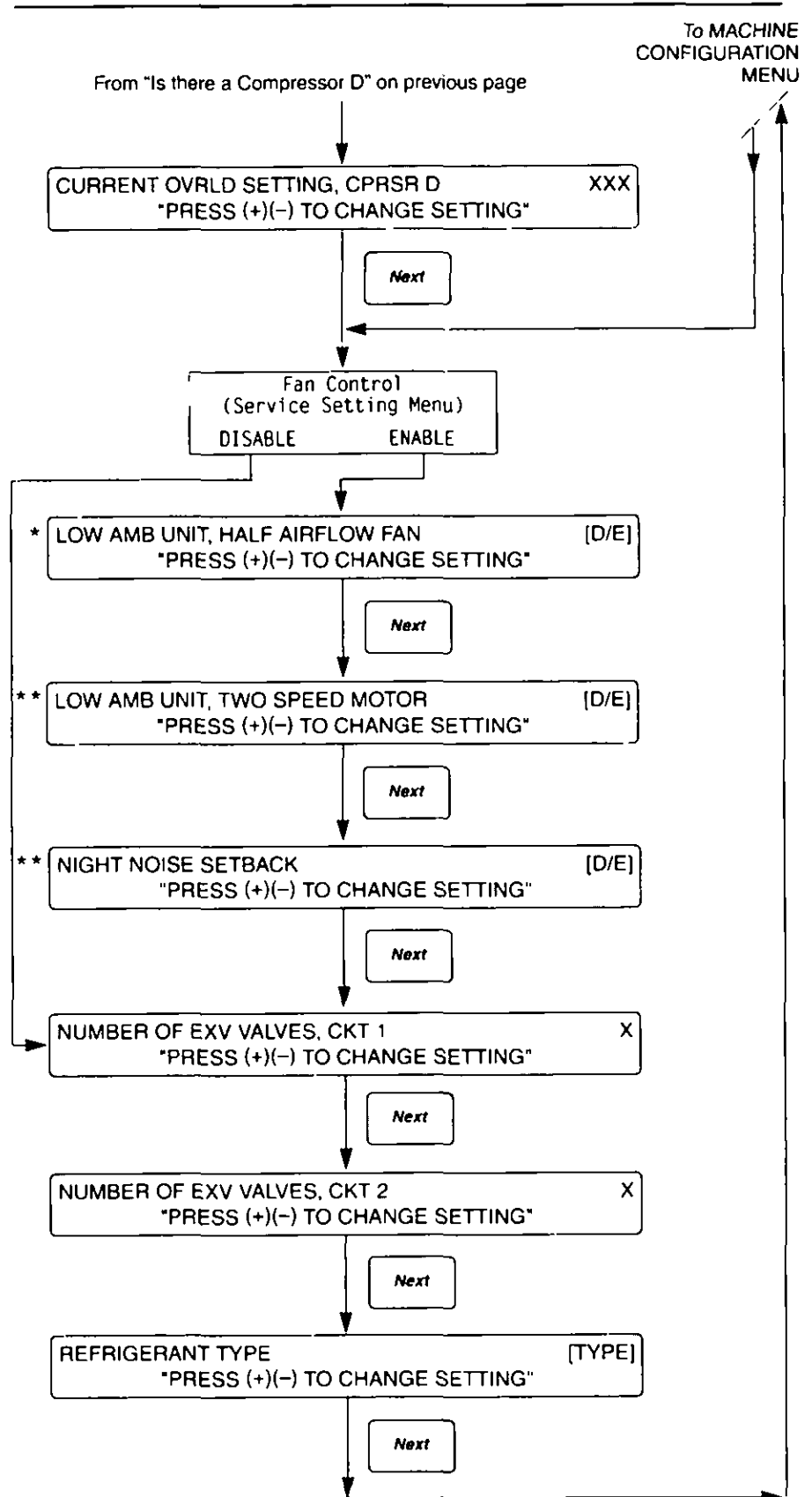
Default - 1  
 Select - 1, 2

Default - 1  
 Select - 1, 2

Default - R22  
 Select - R22, R134a

**CAUTION: RTAA 70 - 100 ton  
 units are to be run with R22  
 refrigerant. Contact a qualified  
 service technician for further  
 details.**

RTAA-IOM-4A



SERVICE SETTINGS

MACHINE CONFIGURATION

SERVICE TESTS

**Figure 32**  
**Service Tests**

Default - Disable

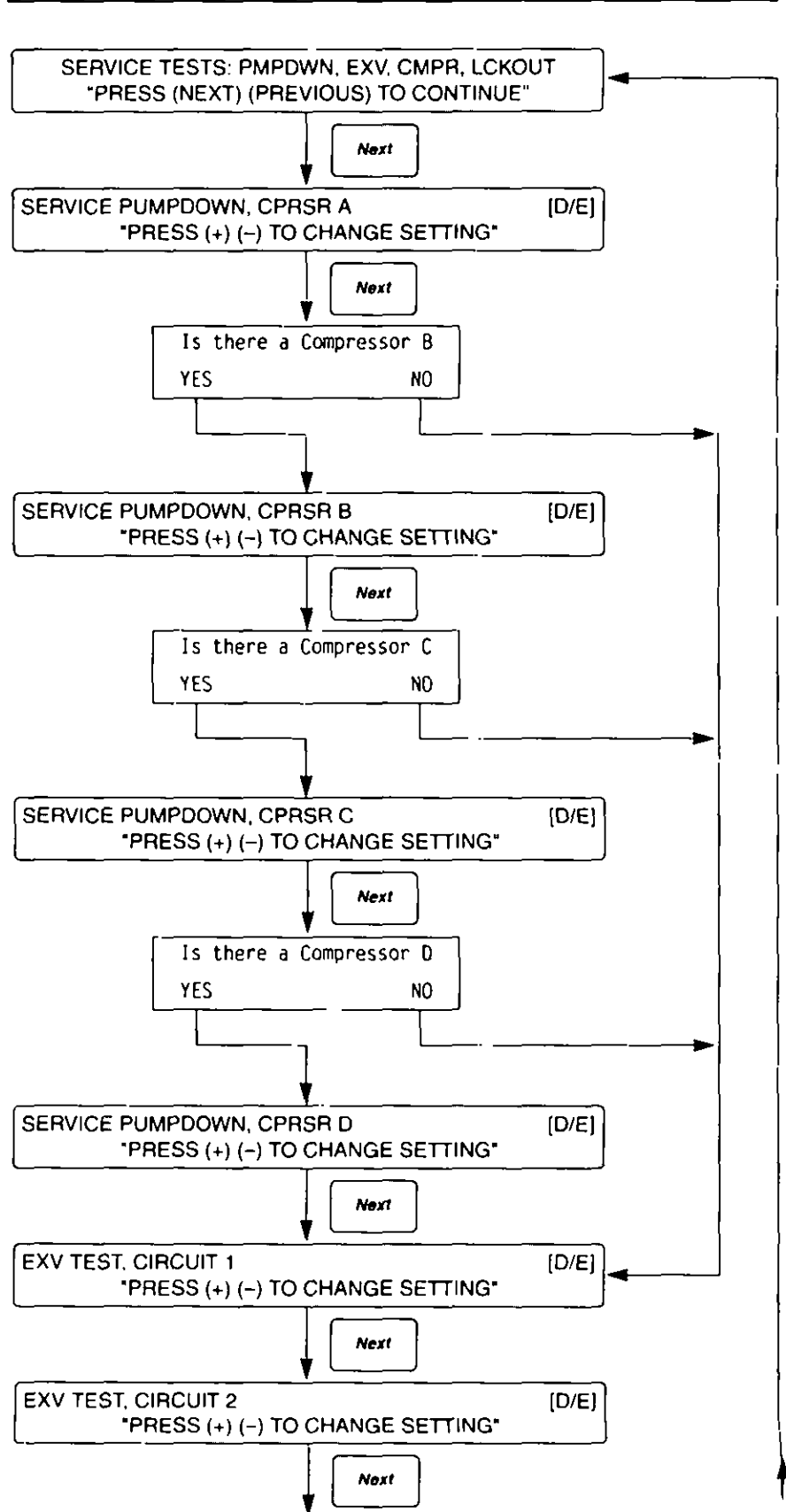
Default - Disable

Default - Disable

Default - Disable

Default - Disable

Default - Disable



To COMPRESSOR TEST, CPRSR A on next page

**Figure 32**  
**Service Tests**  
 (Continued from previous page)

Default = Disable

Default = Disable

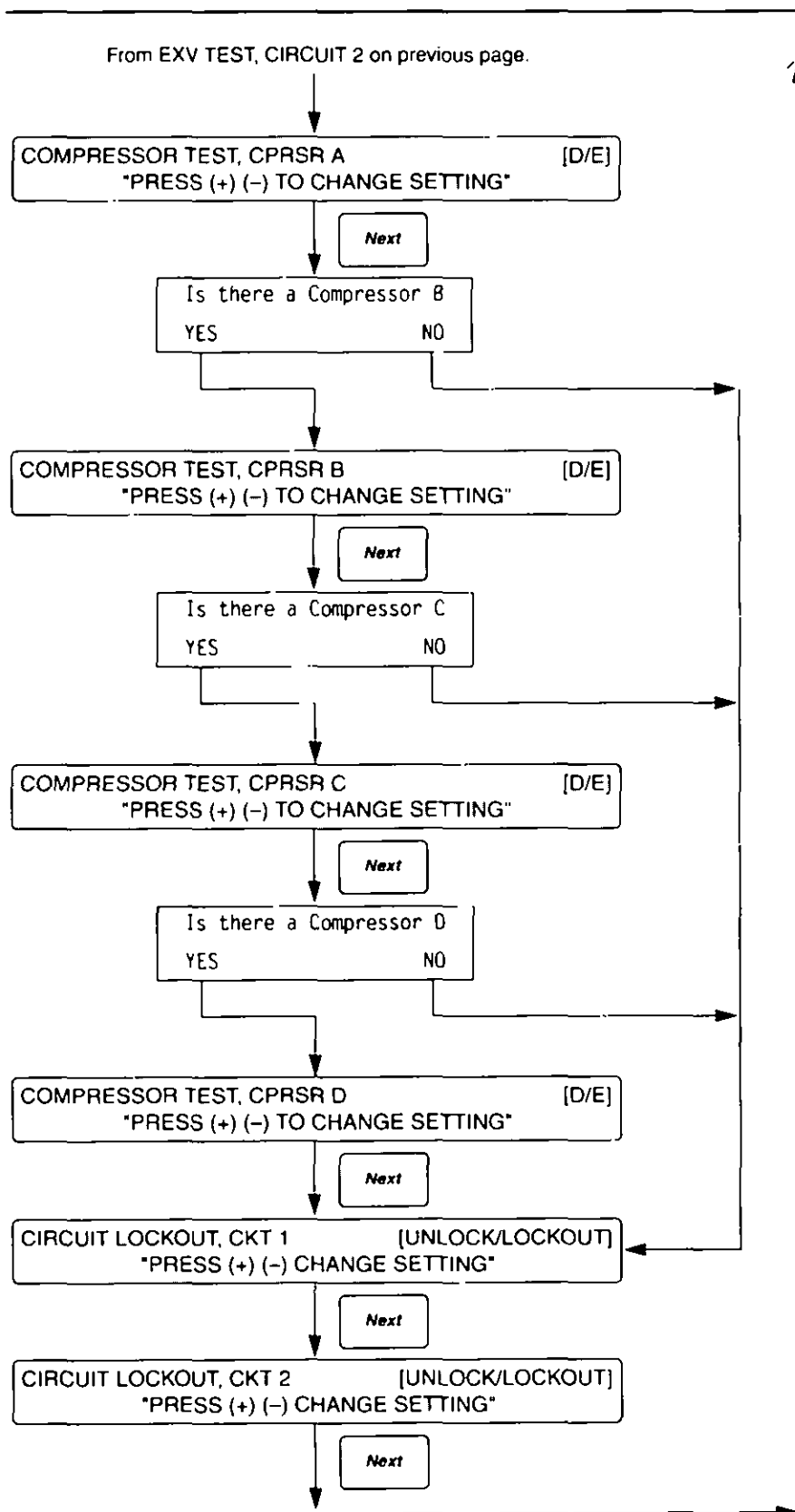
Default = Disable

Default = Disable

Default = UNLOCK

Default = UNLOCK

**SERVICE TESTS**



---

## Diagnostics

If there are no diagnostic messages, the selected menu item will be displayed continuously. If the Diagnostics key is pressed and there are no active diagnostics, the readout on the display will be

NO ACTIVE DIAGNOSTICS PRESENT

When a system malfunction occurs, one of the following appropriate diagnostic messages will be displayed:

\*\*\*A MACHINE SHUTDOWN HAS OCCURRED!\*\*\*

A MACHINE SHUTDOWN OCCURRED  
BUT HAS CLEARED "PRESS (NEXT)"

\*\*\*A CIRCUIT SHUTDOWN HAS OCCURRED!\*\*\*

A CIRCUIT SHUTDOWN OCCURRED  
BUT HAS CLEARED "PRESS (NEXT)"

\*\*\*INFORMATIONAL WARNING\*\*\*

AN INFORMATIONAL WARNING OCCURRED  
BUT HAS CLEARED "PRESS (NEXT)"

When a Circuit Shutdown – Manual Reset (CMR) or a Machine Shutdown – Manual Reset (MMR) occurs, the red LED to the right of the display will flash. Otherwise this alarm LED is deenergized

If more than one diagnostic is present, only the highest priority active diagnostic will be explained in detail. For example, if three diagnostics occur in the following order before the operator returns – IFW, MMR, CMR – the display will read

\*\*\* A MACHINE SHUTDOWN HAS OCCURRED! \*\*\*

because the MMR has the highest priority. However, as the operator moves through the diagnostic menu to the "Last Diagnostic", the [Diagnostic Description] will show the CMR diagnostic as well as the IFW. If the "Next" key is pressed, the display will show all other active and historic diagnostics.

The active diagnostic priorities, listed from highest to lowest are:

Machine Shutdown –  
Manual Reset (MMR)

Machine Shutdown –  
Automatic Reset (MAR)

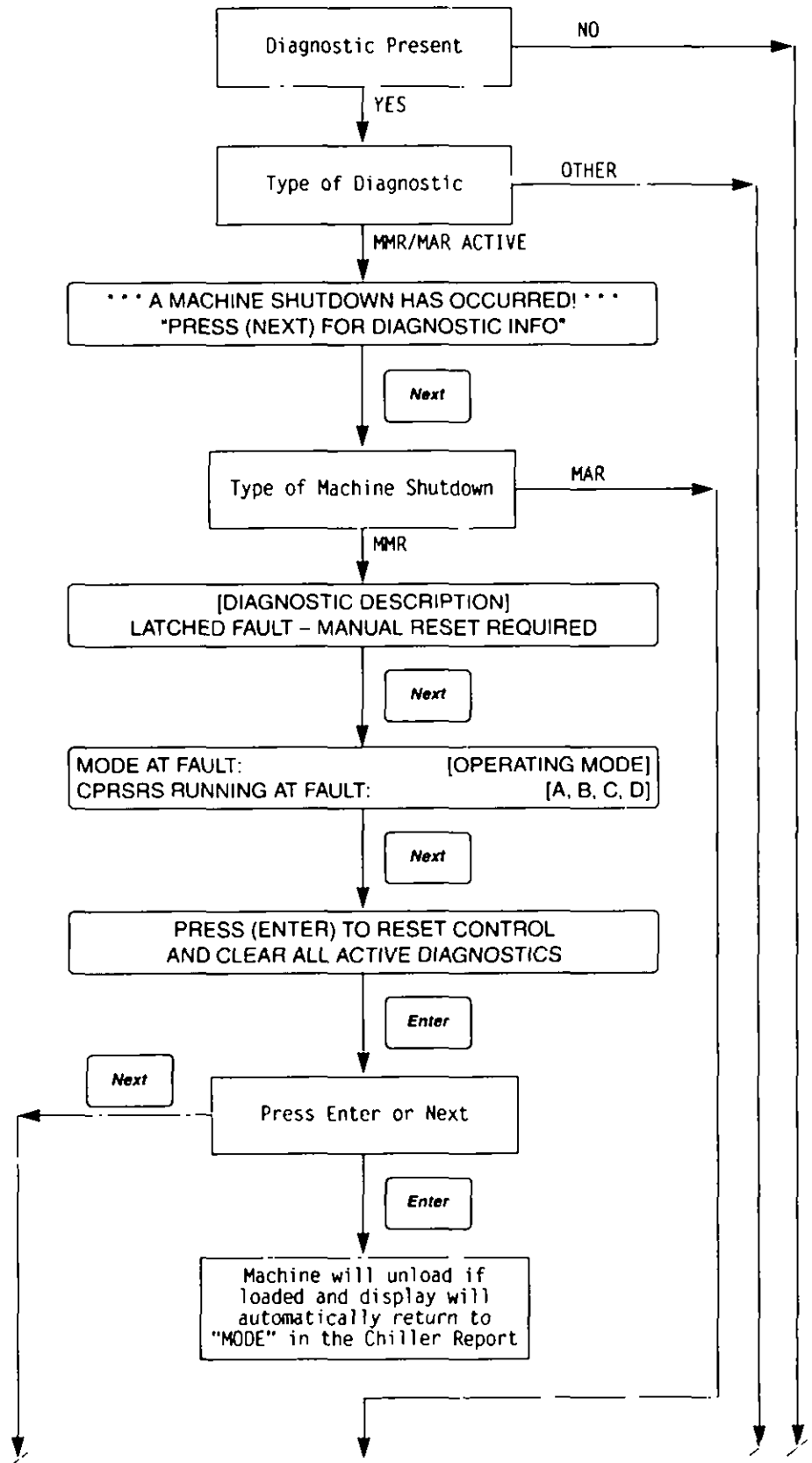
Circuit Shutdown –  
Manual Rest (CMR)

Circuit Shutdown –  
Automatic Reset (CAR)

Informational Warning (IFW)

The flow chart in Figure 33 shows the display readouts found under the Diagnostics Menu. By following the steps shown in the flowchart, a brief description on the diagnostic can be viewed. Use the Next key to enter the main diagnostic menu, where diagnostics can be cleared.

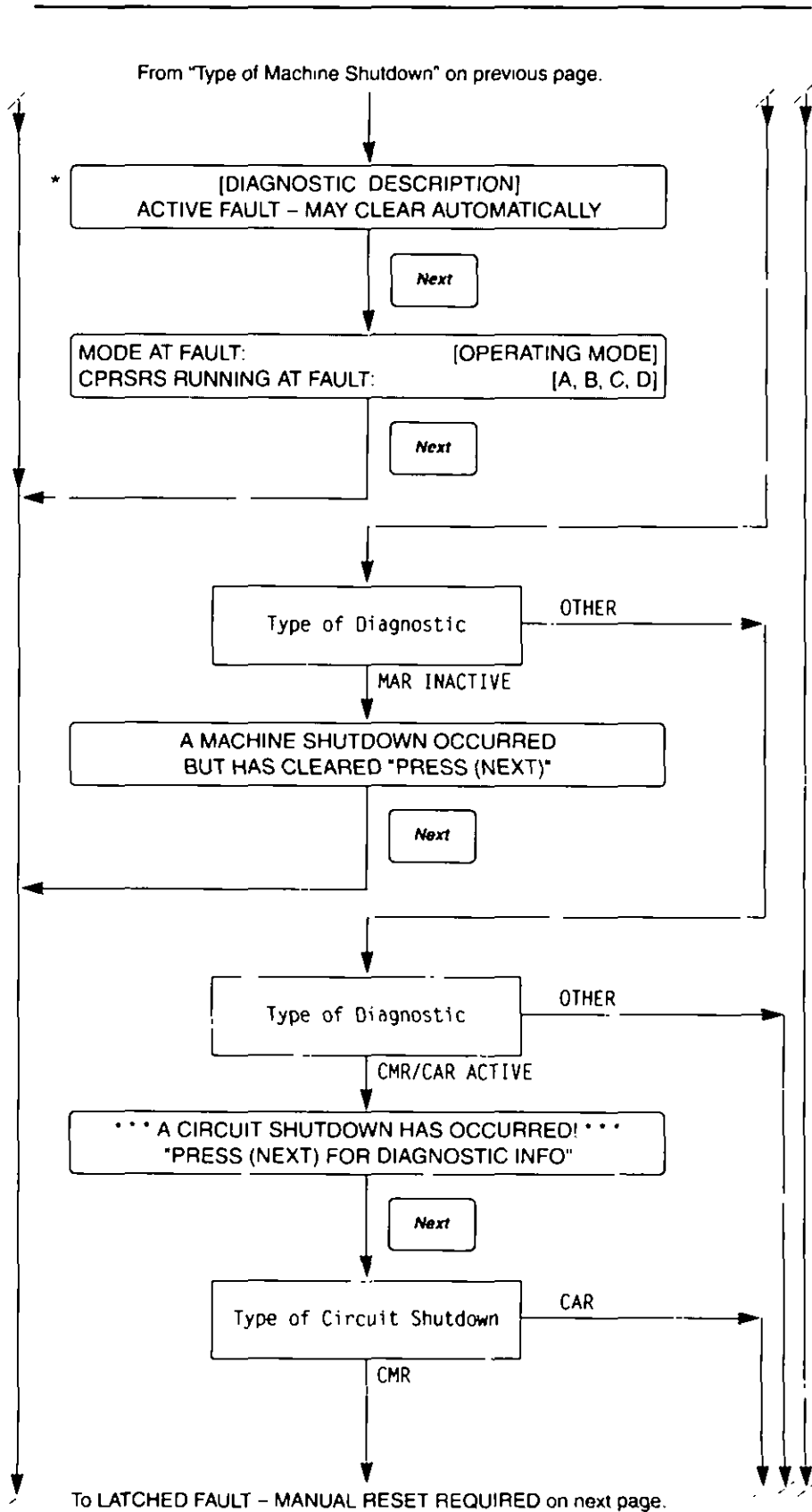
Figure 33  
Diagnostics



To [DIAGNOSTIC DESCRIPTION] on next page.

**Figure 33**  
**Diagnostics**  
 (Continued from previous page)

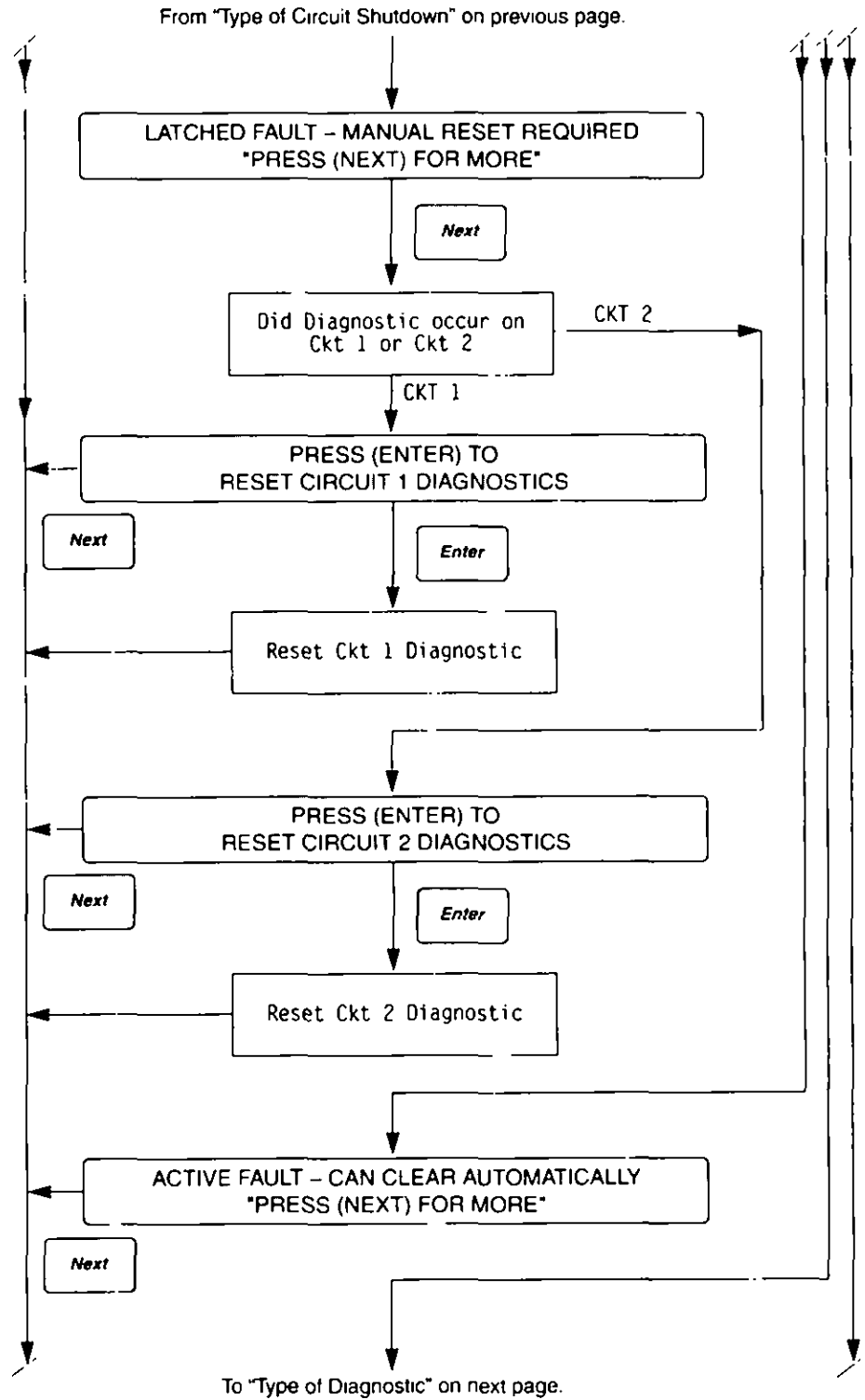
\* Refer to Table 8 for diagnostic descriptions.



**DIAGNOSTICS**

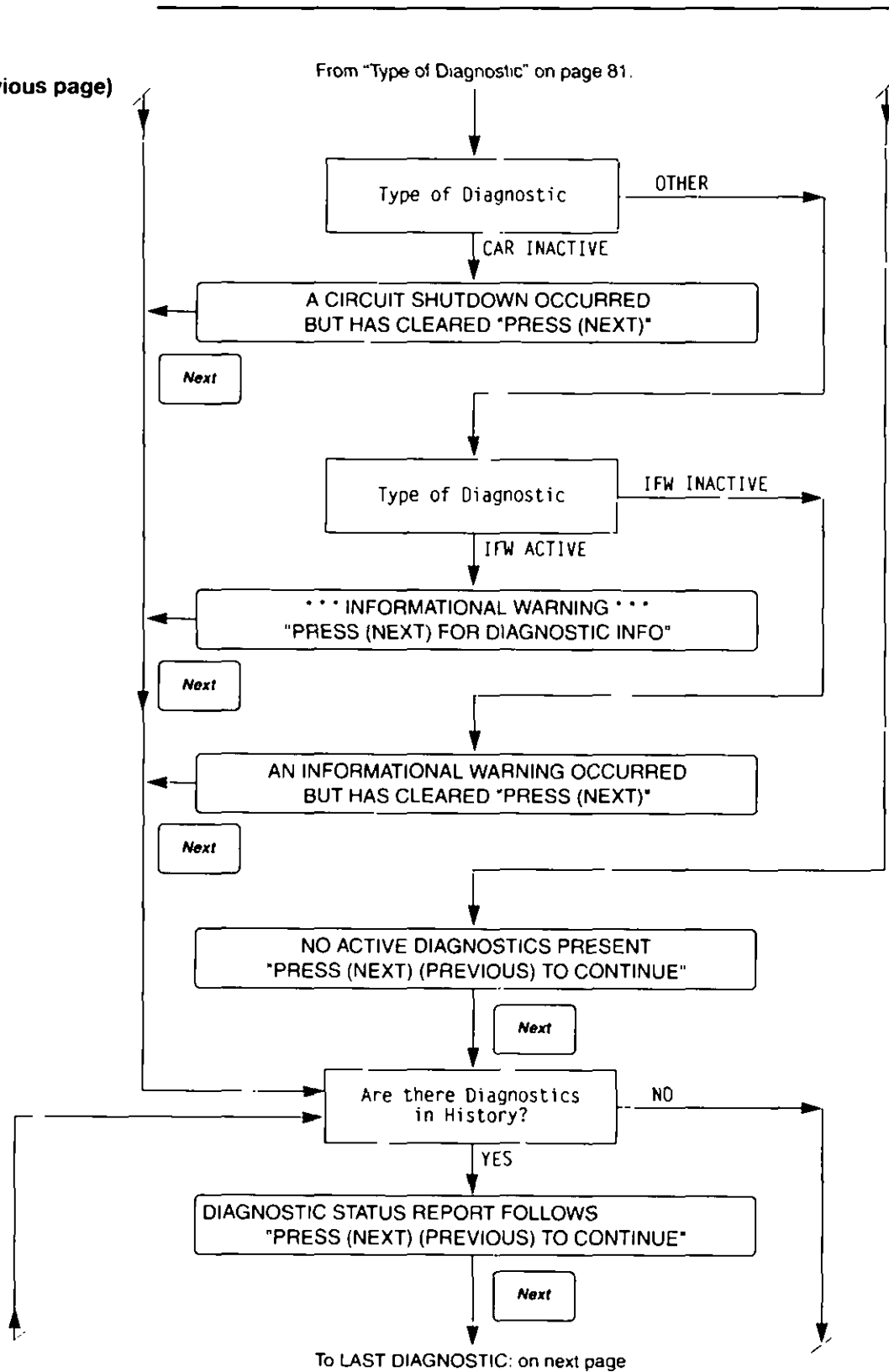


**Figure 33**  
**Diagnostics**  
 (Continued from previous page)



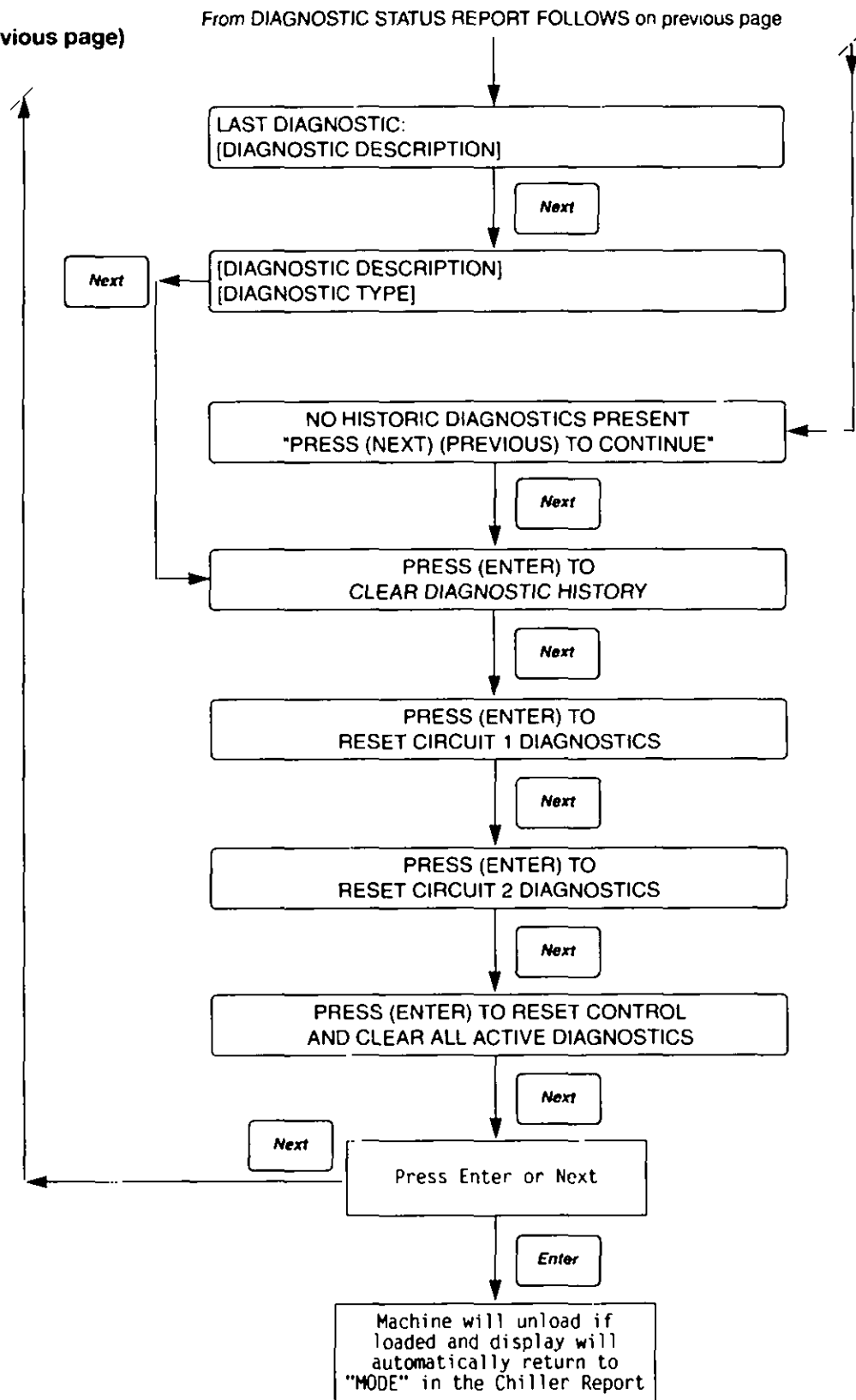
**DIAGNOSTICS**

**Figure 33**  
**Diagnostics**  
 (Continued from previous page)



**DIAGNOSTICS**

**Figure 33**  
**Diagnostics**  
 (Continued from previous page)



**DIAGNOSTICS**

**Table 8**

**Diagnostic Codes**

In the table below a "LATCHING" diagnostic is a condition which shall cause the machine or a portion of the machine as noted to shut down and shall require a manual reset to restore operation. A diagnostic that is non-latching shall reset automatically when the condition causing the diagnostic goes away. A non-latching diagnostic shall shut down the machine or a part of the machine if so indicated. If a diagnostic is informative only, no machine or circuit action is taken except to load a diagnostic code into the last diagnostic register.

Diagnostic Types (And Action)

- MMR - Machine Shutdown, Manual Reset
- MAR - Machine Shutdown, Auto Reset
- CMR - Circuit Shutdown, Manual Reset
- CAR - Circuit Shutdown, Auto Reset
- IFW - Information/Warning

<u>DIAGNOSTIC DESCRIPTION</u>	<u>TYPE</u>	<u>CAUSE</u>
Chilled Water Flow (Ent Wtr Temp)	MMR	a. The entering evaporator water temp. fell below the leaving evaporator water temp. by more than 2F for 100 degree F - seconds. b. Causes to trip this diagnostic include either a loss of chilled water flow or a calibration shift in the evaporator water temp. sensors.
Chilled Water flow Interlock	MAR	The chilled water flow switch input was open for more than 6 seconds.
Compressor Overload Setting - Cprsr A	IFW	The CPM NovRam Based overload setting did not agree with the MCSP Dip Switch overload setting for 30 contiguous seconds. The affected MCSP shall use the minimum (00000 binary, 00 decimal) overload setting as a default until the UCM is reset when this diagnostic occurs.
Compressor Overload Setting - Cprsr B	IFW	Same as Cprsr A, above.
Compressor Overload Setting - Cprsr C	IFW	Same as Cprsr A, above.
Compressor Overload Setting - Cprsr D	IFW	Same as Cprsr A, above.
Cond Fan Var Speed Drive Fault Ckt 1	IFW	The controlling MCSP for the given circuit has unsuccessfully attempted (5 times within 1 minute) to clear a fault signal from the Condenser Fan Inverter Drive. The 5th attempt removes power from the inverter to create a power up reset. If the fault does not clear, the LCM will revert to constant speed operation without the use of the inverter's fan. The inverter must be manually bypassed for full fixed speed fan operation.
Cond Fan Var Speed Drive Fault Ckt 2	IFW	Same as Ckt 1, above.
Cond Entering Wtr Temp Sensor	IFW	Shorted Cond. temp. sensor. No diagnostic on open.
Cond Leaving Wtr Temp Sensor	IFW	Shorted Cond. temp. sensor. No diagnostic on open.
Cond Rfgr Temp Sensor - CKT 1	CMR	Open or short.
Cond Rfgr Temp Sensor - CKT 2	CMR	Open or short.
Contactors CPRSR A	MMR	a. Welded cprsr contactor. b. Detected a welded compressor contactor when the compressor was commanded off but the current does not go to zero. Detection time shall be 5 second minimum and 10 seconds maximum. On detection, generate the diagnostic, energize the appropriate alarm relay, continue to command the affected compressor off, energize the affected compressors oil line solenoid, stop all other compressors, unload the running compressor with the welded contactor, open the EXV to its maximum open position, and continue to do fan control. Do not exit this condition until the controller is manually reset.

**Table 8**  
**Diagnostic Codes (Continued)**

DIAGNOSTIC DESCRIPTION	TYPE	CAUSE
Contactora CPRSR B	MMR	Same as CPRSR A.
Contactora CPRSR C	MMR	Same as CPRSR A.
Contactora CPRSR D	MMR	Same as CPRSR A.
CPRSR Suct Temp Sensor - Ckt 1	CMR	Open or short.
CPRSR Suct Temp Sensor - Ckt 2	CMR	Open or short.
CWS/Leaving Water Temp Cutout Setpoint Overlap	None	No diagnostic, display to flash and limit value to last legal value.  NOTE: The above is not a diagnostic because you don't want the display vectoring you to a different display state when you are trying to set either the chilled water setpoint or the leaving water temp. cutout setpoint as it will in the case of a diagnostic.
Discharge Temp - Cprsr A	CMR	a. The discharge temp. exceeded the trip value: 135 + or - 3 C. b. The discharge temp. PTC or wiring is open. c. Time to trip from either trip value exceeded or input open shall be 0.5 to 2.0 seconds.
Discharge Temp - Cprsr B	CMR	Same as Diagnostic for Cprsr A, above.
Discharge Temp - Cprsr C	CMR	Same as Diagnostic for Cprsr A, above.
Discharge Temp - Cprsr D	CMR	Same as Diagnostic for Cprsr A, above.
Emergency Stop	MMR	EMERGENCY STOP input is open. An external interlock has tripped. Time to trip from input opening to unit stop shall be 0.1 to 1.0 seconds.
Entering Oil Temp Sensor - Cprsr A	CMR	Open or short.
Entering Oil Temp Sensor - Cprsr B	CMR	Open or short.
Entering Oil Temp Sensor - Cprsr C	CMR	Open or short.
Entering Oil Temp Sensor - Cprsr D	CMR	Open or short.
Evap Entering Wtr Temp Sensor	MMR	Open or short.
Evap Leaving Wtr Temp Sensor	MMR	Open or short.
Evap Rfqt Temp Sensor - CKI 1	CMR	Open or short (for 30 sec).
Evap Rfqt Temp Sensor - CKI 2	CMR	Open or short (for 30 sec).
External Chilled Water Setpoint	IFW	a. Not "Enabled": no diagnostics. b. "Enabled": Out-Of-Range Low, set diagnostic. Out-Of-Range Hi, no diagnostic.
External Current Limit Setpoint	IFW	a. Not "Enabled": no diagnostics. b. "Enabled": Out-Of-Range Low, set diagnostic. Out-Of-Range Hi, no diagnostic.
EXV Elec. Drive CKT - Rfqt Ckt 1	CMR	Run the EXV electrical drive circuit test both on demand from the human interface and just before either a circuit or one of a pair of circuits starts.
EXV Elec. Drive CKT - Rfqt Ckt 2	CMR	Same as Diagnostic for Ckt 1, above.
High Diff. Press. - Ckt 1	CMR	The difference between the Condenser pressure and the evaporator pressure exceeded 350 PSID for 0.8-5.0 seconds. 320 PSID must hold. 320+ to trip in One Hour.
High Diff. Press - Ckt 2	CMR	Same as Diagnostic for Ckt 1, above.

**Table 8**  
**Diagnostic Codes (Continued)**

<u>DIAGNOSTIC DESCRIPTION</u>	<u>TYPE</u>	<u>CAUSE</u>
High Oil Temp - Cprsr A	CMR	Entering Oil Temp to given compressor exceeded 170F. Time to trip is given by equation: trip time = (190 Oil Temp) x 180 sec/F.
High Oil Temp - Cprsr B	CMR	Same as Cprsr A, above.
High Oil Temp - Cprsr C	CMR	Same as Cprsr A, above.
High Oil Temp - Cprsr D	CMR	Same as Cprsr A, above.
High Pressure Cutout Cprsr A	CMR	A high pressure cutout was detected on Cprsr A; trip at 405 + or - 7 PSIG.
High Pressure Cutout Cprsr B	CMR	A high pressure cutout was detected on Cprsr B; trip at 405 + or - 7 PSIG.
High Pressure Cutout Cprsr C	CMR	A high pressure cutout was detected on Cprsr C; trip at 405 + or - 7 PSIG.
High Pressure Cutout Cprsr D	CMR	A high pressure cutout was detected on Cprsr D; trip at 405 + or - 7 PSIG.
Loss of Local Display Panel COM	IFW	The IUI has detected a loss of IPC communication with the Local Display panel for at least 15 seconds.
Low Chilled Water Temp (Unit off)	IFW	The chilled water temp. fell below the cutout setpoint while the compressors were not running.
Low Chilled Water Temp (Unit on)	MAR	The chilled water temp. fell below the cutout setpoint while the compressors were running for 30 degree F seconds.
Low Differential Press - Ckt 1	CMR	The fan control algorithm detected a low differential Temperature/Pressure condition that existed for more than 180 contiguous seconds. Trip point is 40 PSID.
Low Differential Press Ckt 2	CMR	Same as Diagnostic for Ckt 1, above.
Low Evap Rfqt Temp - Ckt 1	CMR	a. The Saturated Evap Rfqt Temp - Circuit 1 dropped below the low Rfqt Temp Cutout Setpoint while the circuit was running for 30 deg F seconds. b. See the low ambient ignore time on startup.
Low Evap Rfqt Temp Ckt 2	CMR	Same as Diagnostic for Ckt 1, above.
Low Oil Flow - Cprsr A	CMR	The differential oil pressure switch remained opened for more than 20 contiguous seconds on Cprsr A. Note: Although GP cmprs do not have pressure switch or Oil Line solenoid, this diagnostic is still active. The input must be jumpered for normal operation on GP cmprs.
Low Oil Flow - Cprsr B	CMR	Same as Diagnostic for Cprsr A, above, but Cprsr B.
Low Oil Flow - Cprsr C	CMR	Same as Diagnostic for Cprsr A, above, but Cprsr C.
Low Oil Flow - Cprsr D	CMR	Same as Diagnostic for Cprsr A, above, but Cprsr D.
Low Pressure Cutout Ckt 1	CMR	The low pressure switch opened or remained open past the ignore time during compressor operation (after one retry) or the low pressure switch was open prior to compressor start with Sat Cond Temp above -18F.
Low Pressure Cutout Ckt 2	CMR	Same as Ckt 1.
Low Superheat - Ckt 1	CMR	A low superheat condition existed for an extended period of time. If a superheat less than or equal to 2 degrees F (1.11 degrees C) is detected for more than 2400 degree F seconds, the circuit shall be shutdown. The integrated area (2400 Degree F seconds) shall be only below 2 degrees F superheat.
Low Superheat - Ckt 2	CMR	Same as Diagnostic for Ckt 1, above.

**Table 8**  
**Diagnostic Codes (Continued)**

<u>DIAGNOSTIC DESCRIPTION</u>	<u>TYPE</u>	<u>CAUSE</u>
Memory Error Type I	IFW	On UCM either power up or following a type II Memory Error a NOVRAM memory error was detected. The UCM is operating on all Engineering ROM defaults for all setup parameters. Check all setup parameters and continue to run chiller. Replace the Chiller Module as soon as a replacement is available.  NOTE: It is expected that this diagnostic will be detected on the very first power up of the Chiller Module at the Manufacturer since the NOVRAM will not contain valid data on first power up.
Memory Error Type II	IFW	A Shadow RAM memory error was detected. The UCM is operating on all last valid values (pulled from NOVRAM) for all setup parameters. No setup parameter changes were pending to be loaded into NOVRAM, a complete recovery of all setup parameters was made and there is no need to check unit setup parameters. Compressor starts and hour were lost for not more than the last 24 hours. This is expected to be an isolated event and repair or replacement is not required. If this diagnostic does occur repeatedly, then replace the Chiller module.
Memory Error Type III	IFW	A Shadow RAM memory error was detected. The UCM is operating on all last valid values (pulled from NOVRAM) for all setup parameters. Setup parameter changes less than 24 hours old pending to be loaded into NOVRAM were lost. Check all setup parameters made in the last 24 hours. Compressor starts and hours were lost for not more than the last 24 hours. This is expected to be an isolated event and repair or replacement is not required. If this diagnostic does occur repeatedly, then replace the Chiller module.
Oil System Fault - Ckt 1	CMR	Entering Oil Temp on either compressor of the given circuit reads a temperature x degrees below the given ckt's saturated condenser temperature for more than 30 minutes where x is the Oil Loss Differential Setpoint (2 degree F hysteresis to clear timer).
Oil System Fault - Ckt 2	CMR	Same as for Ckt. 1, above.
Outdoor Air Temp Sensor (Both Outdoor Air Reset and Low Ambient Lockout not selected.)	None	Open or short. a. Display dashes e.g. "14-...".
Outdoor Air Temp Sensor (Either Outdoor Air Reset or Low Ambient Lockout selected.)	IFW	Open or short. a. Use end of range value (whatever value the open or short. b. Clear diag. when the resistance returns to normal range.
Over Voltage	MAR	Line voltage above + 10% of nominal. (Must hold = + 10% of nominal. Must trip = + 15% of nominal. Reset differential = min. of 2% and max. of 4%. Time to trip = minimum of 10 sec. and maximum of 20 seconds.)  Design: Nom. trip: 15 seconds at greater than 113.5%, ± 2.8% at 200V, or ± 1.8% at 575V, Auto reset at 110.5% or less.
Overload Trip - CPRSR A	CMR	Cprsr current exceeded overload time vs. trip characteristic.

**Table 8**  
**Diagnostic Codes (Continued)**

<b>DIAGNOSTIC DESCRIPTION</b>	<b>TYPE</b>	<b>CAUSE</b>
Overload Trip - CPRSR B	CMR	Same as Diagnostic for Cprsr A.
Overload Trip - CPRSR C	CMR	Same as Diagnostic for Cprsr A.
Overload Trip - CPRSR D	CMR	Same as Diagnostic for Cprsr A.
Phase Loss - Cprsr A	CMR	No current was sensed on one or more of the current x former inputs. (Must hold - 20% RIA. Must trip - 5% RIA.) Time to trip shall be 1 second minimum, 3 seconds maximum.
Phase Loss - Cprsr B	CMR	Same as Diagnostic for Cprsr A, above.
Phase Loss - Cprsr C	CMR	Same as Diagnostic for Cprsr A, above.
Phase Loss - Cprsr D	CMR	Same as Diagnostic for Cprsr A, above.
Phase Reversal - Cprsr A	CMR	A phase reversal was detected on the incoming current. On a compressor startup the phase reversal logic must detect and trip in a maximum of 1.0 second from compressor start.
Phase Reversal - Cprsr B	CMR	Same as Diagnostic for Cprsr A, above.
Phase Reversal - Cprsr C	CMR	Same as Diagnostic for Cprsr A, above.
Phase Reversal - Cprsr D	CMR	Same as Diagnostic for Cprsr A, above.
Phase Rev Prot Lost - Cprsr A	CMR	The phase reversal protection on compressor A has become inoperative. The phase rotation protector system failed to detect 2 in a row of one of the four phase circuit states: Phase reversal, Phase rotation OK, Phase A lost, Phase B lost.
Phase Rev Prot Lost - Cprsr B	CMR	Same as Cprsr A, above, but Cprsr B.
Phase Rev Prot Lost - Cprsr C	CMR	Same as Cprsr A, above, but Cprsr C.
Phase Rev Prot Lost - Cprsr D	CMR	Same as Cprsr A, above, but Cprsr D.
Phase Unbalance - Cprsr A	CMR	A 15% phase unbalance condition has been detected.
Phase Unbalance - Cprsr B	CMR	Same as Diagnostic for Cprsr A.
Phase Unbalance - Cprsr C	CMR	Same as Diagnostic for Cprsr A.
Phase Unbalance - Cprsr D	CMR	Same as Diagnostic for Cprsr A.
Power Loss - Cprsr A	CAR	a. The cprsr was running and all three phases of current were lost. b. There was an open transition input after transition had been previously proven to have been complete. c. There was an incomplete transition on the first check after transition and all three phases of current were not present.
Power Loss - Cprsr B	CAR	Same as Diagnostic for Cprsr A, above.
Power Loss - Cprsr C	CAR	Same as Diagnostic for Cprsr A, above.
Power Loss - Cprsr D	CAR	Same as Diagnostic for Cprsr A, above.
Severe Phase Unbalance - Cprsr A	CMR	A 30% Phase Unbalance diagnostic has been detected. The 15% Phase Unbalance criteria has been defeated. Items to check are the Current Transformer Part Numbers (they should all match). The current Transformer resistances, line voltage phase balance, all power wiring connections, the contactor pole faces, and the motor. If all these are OK, replace the MCSP module of the affected circuit.
Severe Phase Unbalance - Cprsr B	CMR	Same as Diagnostic for Cprsr A, above.
Severe Phase Unbalance - Cprsr C	CMR	Same as Diagnostic for Cprsr A, above.
Severe Phase Unbalance - Cprsr D	CMR	Same as Diagnostic for Cprsr A, above.



**Table 8**  
**Diagnostic Codes (Continued)**

DIAGNOSTIC DESCRIPTION	TYPE	CAUSE
Slaved EXV Elec Drive CKT - Rfgt Ckt 1	CMR	Run the EXV electrical drive circuit test both on demand from the human interface and just before either a circuit or one of a pair of circuits starts.
Slaved EXV Elec Drive CKT - Starter Transition - Cprsr A	CMR	Same as Diagnostic for Ckt 1, above.
Starter Transition - Cprsr B	CMR	a. The UCM did not receive a transition complete signal in the designated time from the UCM command to transition. The must hold time from the UCM transition command is 1 second. The Must trip time from the transition command is 6 seconds.
Starter Transition - Cprsr C	CMR	b. The Transition Complete input was found to be shorted before the compressor was started.
Starter Transition - Cprsr D	CMR	c. Active only if Reduced Inrush Starting is Enabled.
Subcooled Liquid Temp Sensor - Ckt 1	IFW	Same as Diagnostic for Cprsr A, above.
Subcooled Liquid Temp Sensor - Ckt 2	IFW	Same as Diagnostic for Cprsr A, above.
Tracer Communications Loss	IFW	Same as Diagnostic for Cprsr A, above.
		a. While the chiller switch was in AUTO/REMOTE the communications between the CSR and the connected remote device, e.g., a Tracer or Remote Display, had either never been established for more than 15 minutes after power up or had been lost for more than 15 minutes after it had been established; use the Front Panel Setpoints and the Default Chiller Auto/Stop.
		b. In AUTO/LOCAL communications had been established and was then lost for more than 15 minutes. Regardless of the remote communications status the UCM uses Front Panel setpoints.
		NOTE: The active modes for this diagnostic follow the positions of the chiller switch which account for other chiller modes.
Under Voltage	MAR	Line voltage below 10% of nominal or the Under/Over transformer is not connected. (Must hold = - 10% of nominal. Must trip - - 15% of nominal. Reset differential = min. of 2% and max. of 4%. Time to trip = min. of 10 sec. and max. of 20 sec.)
		Design: Nom. trip: 15 seconds at less than 87.5%, ± 2.8% at 200V, or ± 1.8% at 575V, Auto reset at 90.5% or greater.
U1 Indicating U2 Communications	IFW	The U1 has det. a loss of IPC comm from the U2 module.
U1 Indicating U3 Communications	MMR	The U1 has det. a loss of IPC comm from the U3 module.
U1 Indicating U4 Communications	CMR	The U1 has det. a loss of IPC comm from the U4 module.
U1 Indicating U5 Communications	CMR	The U1 has det. a loss of IPC comm from the U5 module.
U1 Indicating U6 Communications	CMR	The U1 has det. a loss of IPC comm from the U6 module.
U1 Indicating U7 Communications	CMR	The U1 has det. a loss of IPC comm from the U7 module.
U3 Indicating U1 Communications	MMR	The U3 has det. a loss of IPC comm from the U1 module.
U3 Indicating U4 Communications	CMR	The U3 has det. a loss of IPC comm from the U4 module.
U3 Indicating U5 Communications	CMR	The U3 has det. a loss of IPC comm from the U5 module.
U3 Indicating U6 Communications	CMR	The U3 has det. a loss of IPC comm from the U6 module.
U3 Indicating U7 Communications	CMR	The U3 has det. a loss of IPC comm from the U7 module.

**Table 8**  
**Diagnostic Codes (Continued)**

<u>DIAGNOSTIC DESCRIPTION</u>	<u>TYPE</u>	<u>CAUSE</u>
U4 Indicating U1 Communications	CMR	The IU4 has det. a loss of IPC comm from the IU1 module.
U4 Indicating U3 Communications	CMR	The IU4 has det. a loss of IPC comm from the IU3 module.
U4 Indicating U5 Communications	CMR	The IU4 has det. a loss of IPC comm from the IU5 module.
U5 Indicating U1 Communications	CMR	The IU5 has det. a loss of IPC comm from the IU1 module.
U5 Indicating U3 Communications	CMR	The IU5 has det. a loss of IPC comm from the IU3 module.
U5 Indicating U4 Communications	CMR	The IU5 has det. a loss of IPC comm from the IU4 module.
U6 Indicating U1 Communications	CMR	The IU6 has det. a loss of IPC comm from the IU1 module.
U6 Indicating U3 Communications	CMR	The IU6 has det. a loss of IPC comm from the IU3 module.
U6 Indicating U7 Communications	CMR	The IU6 has det. a loss of IPC comm from the IU7 module.
Winding Temp - Cprsr A	CMR	a. The motor winding temperature thermostat opened; nominally 221 F. b. The motor temp. thermostat or wiring is open. c. Time to trip from input open to compressor shutdown shall be 0.5 to 2.0 seconds.
Winding Temp - Cprsr B	CMR	Same as Diagnostic for Cprsr A, above.
Winding Temp - Cprsr C	CMR	Same as Diagnostic for Cprsr A, above.
Winding Temp - Cprsr D	CMR	Same as Diagnostic for Cprsr A, above.
Zone Temp Sensor (Zone Reset Selected)	IFW	Open or Short. a. Use end of range value (whatever value the open or short gives). b. Clear diag. when the resistance returns to normal range. c. If Shorted, go into the ice making mode if "Ice Machine Control" is enabled.
Zone Temp Sensor (Zone Reset not Selected)	None	a. If Open, do normal chiller control. b. If Shorted, go into the ice making mode if "Ice Machine Control" is enabled.

## Operational Features

### Entering Evaporator Water Temperature

When one or both compressors are running, the UCM continually monitors and compares the entering and leaving evaporator water temperatures. If the temperature of the entering water drops more than 2 F below the leaving water temperature for more than 100 degree F seconds, the UCM uses this to indicate a loss of water flow through the evaporator. This will shut down that circuit's compressor and will display an MMR diagnostic.

### Current Limit Setpoint

The current limit setpoints for the system (front panel or remote) are entered through the Clear Language Display menus. The current limit setpoint for each compressor is shown in Table 9

Based upon current levels received at the UCM, the compressor slide valve is modulated to prevent the actual chiller current from exceeding the CLS.

When a compressor is turned off, the CLS for the remaining running compressor shall be reset upward immediately. When a compressor is added, the CLS for the running compressor shall be ramped downward at a rate not less than 10% RLA per minute to the new setpoint.

### Low Ambient Lockout

The lockout provides a method for preventing unit start-up when the outdoor air temperature is below the setpoint. If the outdoor temperature goes below the setpoint during operation, the UCM will go through a normal shutdown of the unit. If the outdoor temperature subsequently increases to 5 F above the setpoint, the UCM will automatically re-enable the unit. The low ambient lockout feature has a range from -20 F to 60 F.

### Electronic Expansion Valve (EXV) Test

This test can be performed only when the Stop key has been pressed. It will confirm proper operation of the electronic expansion valve and the EXV module.

Once the test has been initiated at the Clear Language Display, the UCM will:

1. Overdrive the EXV closed (25 seconds)
2. Overdrive the EXV open (25 seconds)
3. Overdrive the EXV closed (25 seconds)
4. Reset the display to disable and end the test

The EXV produces an audible clicking sound when it is driven against its end stops. Step 1 drives the EXV to its closed position, during which time service personnel can move from the Clear Language Display to the EXV.

**Note:** A tool may be needed to aid in hearing the clicking of the EXV, such as a screwdriver held between the EXV and the ear.

When Step 1 completes, the clicking stops and the UCM begins to open the EXV. When the EXV is fully opened, the valve will begin to click against its end stop. The service personnel must be prepared to time the period between the end of clicking in Step 1 and the beginning of clicking in Step 2.

The time between the end of clicking in Step 2 and the beginning of clicking in Step 3 must also be recorded. The time for the EXV to go from fully closed to fully open (which is the first time recorded) should be approximately 15 seconds. The time to go back to fully closed (which is the second time recorded) is approximately 15 seconds.

### Current Overload Protection

The UCM continually monitors compressor current to provide unit protection in the event of an overcurrent or locked rotor condition. Protection is based on the phase with the highest current and, if limits are exceeded, the UCM will shutdown the compressor and will display an MMR diagnostic.

### Leaving Chilled Water Temperature Control

If the Auto key is pressed and a remote chilled water setpoint has been communicated, the UCM will control to the Remote Chiller Water Setpoint. Otherwise, it will control to the front panel setpoint. Control is accomplished by both staging compressors and modulating the slide valves on each compressor.

Upon start-up, if the leaving chilled water temperature is dropping 1.5 F per minute or faster, the chiller will not load further.

### Chilled Water Reset (CWR)

As an option, the UCM will reset the chilled water temperature setpoint, based on either the return water temperature, zone air temperature, or outdoor air temperature. The 1U2 Module is necessary to perform CWR.

The following are selectable:

1. One of four RESET TYPEs, from top to bottom in order of reset:

no CWR  
RETURN WATER TEMPERATURE RESET  
ZONE TEMPERATURE RESET  
OUTDOOR AIR TEMPERATURE RESET

The Clear Language Display will not permit more than one type of reset to be selected in the Operator Settings Menu.

2. RESET RATIO Setpoints. For OUTDOOR AIR TEMPERATURE RESET, there are both positive and negative reset ratios.

3. START RESET Setpoints.

4. MAXIMUM RESET Setpoints. The maximum resets are with respect to the chilled water setpoint.

No matter which type of reset is selected, all parameters are factory set to a predetermined set of values. Field adjustment of 2, 3, or 4, above, is usually not required.

**Table 9  
Compressor(s) Current Limit Setpoints vs. Chiller Current Limit Setpoint (CLS)**

System	(70 - 125)	
	Number of compressors in operation	
CLS	One	Two
120%	120	120
100%	120	100
80%	120	80
60%	120	60
40%	80	40

The equations for each type of reset are:

**RETURN WATER TEMPERATURE RESET**

$$CWS' = CWS + RESET\ RATIO (START\ RESET - (TWE - TWL))$$

and  $CWS' > \text{ or } = CWS$

and  $CWS' - CWS < \text{ or } = \text{MAXIMUM RESET}$

**ZONE TEMPERATURE RESET**

$$CWS' = CWS + RESET\ RATIO (START\ RESET - TZONE)$$

and  $CWS' > \text{ or } = CWS$

and  $CWS' - CWS < \text{ or } = \text{MAXIMUM RESET}$

**OUTDOOR AIR TEMPERATURE RESET**

$$CWS' = CWS + RESET\ RATIO (START\ RESET - TOD)$$

and  $CWS' > \text{ or } = CWS$

and  $CWS' - CWS < \text{ or } = \text{MAXIMUM RESET}$

CWS' is the new chilled water setpoint.

CWS is the active chilled water setpoint before any reset has occurred.

RESET RATIO is a user adjustable gain.

START RESET is a user adjustable reference.

TZONE is the zone temperature.

TOD is the outdoor temperature.

TWE is the entering evaporator water temperature.

TWL is the leaving evaporator water temperature.

MAXIMUM RESET is a user adjustable limit, providing the maximum amount of reset

**Note:** When any type of CWR is enabled, the UCM will step the CWS toward the desired CWS' (based on the above equations and setup parameters) at a rate of 1 F every 5 minutes. This applies when the chiller is both running and off. Normally the chiller will start at the Differential-to-Start value above a fully reset CWS or CWS'.

The values for RESET RATIO for each type of reset are:

Reset Type	Reset Ratio Range	Increment English Units	Increment SI Units	Factory Default Value
Return	10 to 120%	1%	1%	50%
Zone	50 to 300%	1%	1%	100%
Outdoor	80 to -80%	1%	1%	10%

The values for START RESET for each type of reset are:

Reset Type	Start Reset Range	Increment English Units	Increment SI Units	Factory Default Value
Return	4 to 30 F (2.2 to 16.7 C)	1 F	0.1 C	10 F (5.6 C)
Zone	55 to 85 F (12.8 to 29.4 C)	1 F	0.1 C	78 F (25.6 C)
Outdoor	50 to 130 F (10 to 54.4 C)	1 F	0.1 C	90 F (32.2 C)

The values for MAXIMUM RESET for each type of reset are:

Reset Type	Maximum Reset Range	Increment English Units	Increment SI Units	Factory Default Value
Return	0 to 20 F (-17.8 to -6.7 C)	1 F	0.1 C	5 F (2.8 C)
Zone	0 to 20 F (-17.8 to -6.7 C)	1 F	0.1 C	5 F (2.8 C)
Outdoor	0 to 20 F (-17.8 to -6.7 C)	1 F	0.1 C	5 F (2.8 C)

---

## Leaving Water Temperature Cutout

This temperature cutout provides protection against freezing caused by low leaving water temperature. The setpoint is both factory set and adjustable from the Service Settings Menu. Temperatures below the setpoint will cause the UCM to accelerate reduction of chiller capacity, even to the point of compressor shutdown. A non-latching diagnostic will be generated if the LWT is below the cutout for more than 30 degree F seconds. See Table 10 for proper settings.

There must be a minimum of 5 F between the cutout temperature and both the front panel and active chilled water setpoints. The Clear Language Display will not permit setting of either the front panel or active chilled water temperatures less than 5 F above this cutout temperature. The second line will state "Limited by Cutout Setpoint, (+) to change".

If the leaving water temperature cutout is set upward, the Clear Language Display will maintain the 5 F minimum and will automatically raise the settings on the front panel and active chilled water setpoints, if necessary.

If the front panel or Active Chilled Water Setpoints were adjusted, the display will show the following when the "Enter" key is pressed:

"FRONT PANEL CHILLED WATER SETPOINT  
HAS BEEN INCREMENTED DUE TO CUTOUT  
SETPOINT CHANGE"

If the leaving water temperature drops below the cutout setpoint while the compressors are de-energized, it will produce an IFW diagnostic. If the leaving water temperature drops below the cutout setpoint while the compressors are energized for 30 F seconds, the unit will shut down on an MAR diagnostic.

## Low Refrigerant Temperature Cutout

Both circuits are protected from a saturated evaporator refrigerant temperature that goes below this setting. The cutout setpoint must be a minimum of 15 F lower than the front panel or active chilled water setpoints. See Table 10 for proper settings.

There must be a minimum of 15 F between the cutout temperature and both the front panel and active chilled water setpoints. The Clear Language Display will not permit setting of either the front panel or active chilled water temperatures less than 15 F above this cutout temperature and the display will flash the last valid temperature.

If the leaving water temperature cutout is set upward, the Clear Language Display will maintain the 15 F minimum and will automatically raise the settings on the front panel and active chilled water setpoints, if necessary.

If the front panel or Active Chilled Water Setpoints were adjusted, the display will show the following when the "Enter" key is pressed:

"FRONT PANEL CHILLED WATER SETPOINT  
HAS BEEN INCREMENTED DUE TO CUTOUT  
SETPOINT CHANGE"

If the saturated evaporator refrigerant temperature for a circuit drops below this setpoint for longer than 30 degree F seconds, the circuit will be shutdown and a CMR diagnostic will be displayed.

**Note:** Ice Termination will allow cutouts to be set anywhere, although when running, software follows 5 F and 15 F rules.

**Table 10**  
**Leaving Fluid Temperature Setpoints**

**Note:** The leaving chilled water temperature is not the same as the ice termination setpoint. The ice termination setpoint is based on entering chilled water temperature. Therefore, the ice termination setpoint, minus temperature drop across the evaporator while in the ice making mode, equals the leaving chilled water temperature.

Leaving Chilled Water Temp -F	Leaving Water Temp Cutout-F	Low Refrig Temp Cutout-F	Recommended *** % Ethylene Glycol	Solution Freeze Point-F
40	35	22	0	32
39	34	20	3	
38	33	18	6	
37	32	17	8	
36	31	15	10	25
35	30	14	12	
34	29	12	14	
33	28	11	15	21
32	27	9	17	
31	26	7	19	
30	25	6	20	16
29	24	4	21	
28	23	2	23	
27	22	0	25	10
26	21	-1	26	
25	20	-3	28	
24	19	-5	29	
23	18	6	30	4
22	17	-8	31	
21	16	10	33	
20	15	11	34	
19	14	-13	35	-3
18	13	15	36	
17	12	-17	37	
16	11	-18	38	
15	10	-19	39	
14	9	21	40	11
13	8	23	41	
12	7	-24	42	
11	6	26	43	
10	5	-27	43	
9	4	29	44	
8	3	-31	45	-21
7	2	32	46	
6	1	-34	47	
5	0	35	47	
4	-1	-37	48	
3	-2	-38	49	
2	3	-39	50	-32
1	4	39	50	
0	-5	-39	50	

\*\*\* Recommended % Ethylene Glycol will give freeze protection consistent with other chiller safety controls (solution freeze point is normally 10°F above refrig temp cutout)

### Low Ambient Temperature Start

The Low Refrigerant Temperature Cutout (LRTC) and Low Pressure Cutout (LPC) on a circuit is ignored, briefly, each time the circuit is started. The "ignore time" is a function of the Saturated Condenser Refrigerant Temperature at the time the compressor starts, as shown in Figure 34.

### Low Refrigerant Temperature Cutout and Low Pressure Cutout Retry

If the LRTC or LPC trips despite the low ambient temperature start logic, the circuit will be permitted to shutdown and retry one time

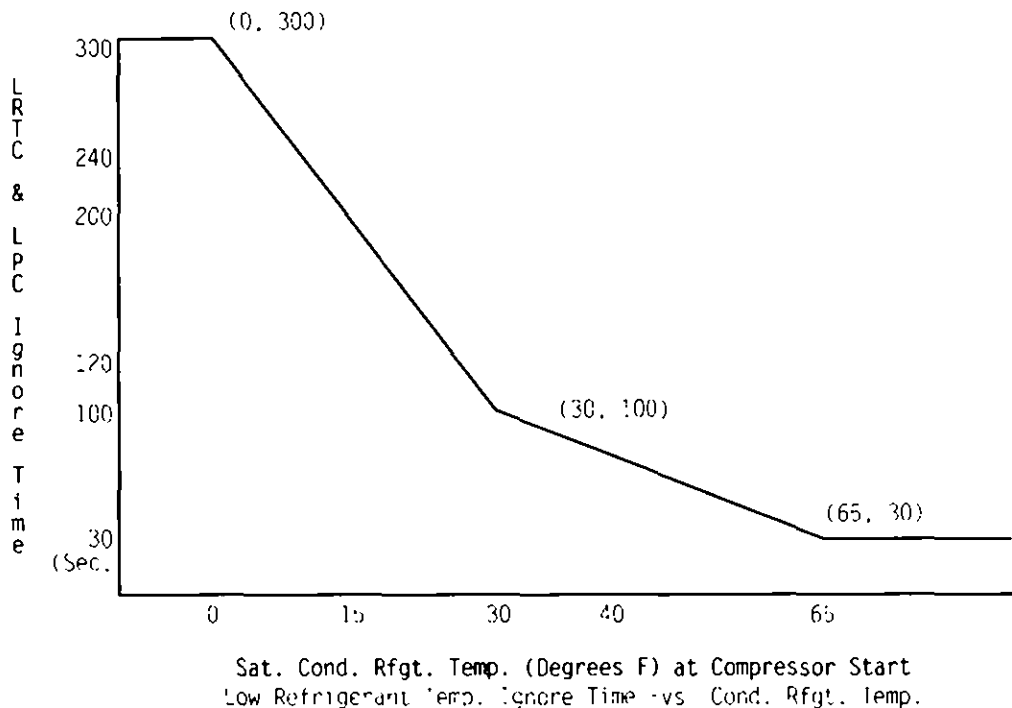
If the LRTC or LPC trips within the first 20 minutes after initial start but after the low ambient ignore time (grace period), the compressor stops immediately and the Restart Inhibit timer is set to one minute. After time expires, the compressor will reset if there is a call for cooling

If the LRTC or LPC trips again during the grace period, a CMR diagnostic will occur. If there is an LRTC or LPC trip anytime after the grace period, a CMR diagnostic will occur

### Balanced Compressor Starts and Hours

This feature is enabled/disabled in Balanced Starts and Hours (Service Settings Menu). When enabled, the UCM will start the compressor with the fewest starts and stop the compressor with the greatest hours, as determined by the "Compressor Starts" accumulator and the "Compressor Hours" accumulator. This will tend to balance out hours and starts equally over both compressors.

**Figure 34**  
**Low Refrigerant Temperature and Low Pressure Cutout Ignore Time**



## Phase Imbalance Protection

The Clear Language Display monitors the current in each phase and calculates the percentage of imbalance as follows.

$$\% \text{ Imbalance} = \frac{(I_x - I_{ave}) \times 100}{I_{ave}}$$

$$I_{ave} = (I_1 + I_2 + I_3) / 3$$

$I_x$  = phase with greatest difference from  $I_{ave}$  (without regard to sign)

If Phase Unbalanced Protection (Service Settings Menu) is enabled, and the average three phase current is greater than 80% RLA, and the percent of imbalance is calculated to exceed 15%, the UCM will shutdown the compressor and display a CMR diagnostic.

In addition to the 15% criteria, the Clear Language Display has a non-defeatable 30% criteria which has its own diagnostic. If the 15% criteria is enabled, it will always display the 15% diagnostic first. The 30% criteria is always active when a compressor is running, regardless of % RLA.

## Reverse Rotation Protection

The Clear Language Display monitors incoming current during start-up and will shutdown the compressor within one second, if phase reversal is detected.

**Caution: Phase relationships during installation of unit power must be carefully controlled to assure compressor protection against reversed phase rotation. See Installation - Electrical.**

## Oil Failure Protection

The 70 to 125 Ton units no longer use the differential pressure switch to monitor for an oil line restriction. The logic of the UCM uses a comparison of the entering oil temperature at the compressor to the saturated condenser temperature to determine if there is an oil line restriction.

The differential between the entering oil temperature and the saturated condenser temperature is referred to as the "Oil Loss Differential Setpoint" in the Service Settings Menu. This setpoint must remain at the default of -4 F for the unit to function properly.

If the entering oil temperature drops 4 F below the saturated condenser temperature for more than 30 minutes, the circuit will shutdown on a CMR diagnostic. The diagnostic will be presented as:

"OIL SYSTEM FAULT — CKT X"

## DIP Switch Settings

### Compressor Overload DIP Switches

The settings for these switches are shown in Table 11.

## IPC Address

The IPC address set the address for Inter-Processor Communications of the Clear Language Display modules. The following is the IPC DIP switch settings for the RTAA 70 – 125 modules.

IPC DIP SWITCH	MODULE			
	1U3	1U4	1U5	1U7
1	OFF	OFF	OFF	OFF
2	OFF	OFF	ON	OFF
3	—	—	—	ON



**Table 11  
Compressor Overload DIP Switch Settings**

Compressor Tons	Volts/Hz	RLA	Primary Turns Through Current Transformer	Current Transformer Extension*	Overload Setting Dip Sw/Decimal 12345**
35	200/60	115	1	02	01011/11
	230/60	100	1	-01	11111/31
	346/50	58	1	-10	01100/12
	380/60	61	1	10	10000/16
	400/50	50	1	-10	00000/0
	460/60	50	1	-10	00000/0
	575/60	40	2	01	01111/15
40	200/60	142	1	-02	11011/27
	230/60	124	1	02	10001/17
	346/50	72	1	-01	00111/7
	380/60	75	1	-01	01010/10
	400/50	62	1	-10	10001/17
	460/60	62	1	-10	10001/17
	575/60	50	2	-01	11111/31
50	200/60	192	1	-03	11100/28
	230/60	167	1	-03	10010/18
	346/50	96	1	01	11100/28
	380/60	101	1	-02	00001/1
	400/50	84	1	-01	10011/19
	460/60	84	1	01	10011/19
	575/60	67	2	-02	10111/23
60	200/60	233	1	04	10011/19
	230/60	203	1	04	01000/8
	346/50	117	1	02	01101/13
	380/60	123	1	02	10001/17
	400/50	101	1	02	00001/1
	460/60	101	1	-02	00001/1
	575/60	81	2	03	10000/16

\* The Current Transformer base part number is X13580253. The numbers in this column are suffixes to the base number.

\*\*On the DIP switch, 1=ON, 0=OFF. The decimal value should be set in the compressor overload setting menu of the UCM. If the DIP switch value does not match the decimal value entered into the UCM, the related compressor(s) will continue to run, but a diagnostic will be initiated, both settings will be ignored, and the UCM will use the lowest possible trip setting value.

## 2-10 VDC/4-20 mA Input for External Chilled Water Setpoint (CWS) and Current Limit Setpoint (CLS)

When either external CWS or external CLS is used on the optional Module 1U2, DIP switch SW1 positions 1 and/or 2 must be set to accommodate the type of signal source the customer has chosen, either 2-10 VDC or 4-20 mA. Position SW1-1 sets 2-10 VDC/4-20 mA for external CWS. SW1-2 sets 2-10 VDC/4-20 mA for external CLS. The "OFF" setting configures the external input for 2-10 VDC; the "ON" setting configures the external input for 4-20 mA.

## Mechanical Control Settings

The settings for the High Pressure switch, Oil Pressure switch, and Winding Thermostat are shown below:

	CLOSE	OPEN
Compressor Discharge High Pressure Switch – PSIG	300 ±20	405 ±7
Compressor Motor Winding Thermostat – F	181	221
Low Pressure Cutout	22 ±4	7 ±4

## Remote CLD Operation

With only few exceptions, operation of the Remote CLD is identical to the unit's CLD. To ease the operation of the Remote CLD, additional displays have been added. For example, if multiple unit operation is used, the following display will be inserted as the second display of the setpoint group:

Modify Setpoints for Units X  
 "Press (+) (-) to change settings"

The Stop and Auto keys function in the same manner, but the following hierarchy between the unit's Stop/Auto keys and the Remote CLD Stop/Auto keys is as follows:

1. Local Stop will always override Local Auto, Remote Stop and Remote Auto
2. Local Auto will always override Local Stop, Remote Stop and Remote Auto.
3. Remote Stop will override Local Auto and Remote Auto but not Local Stop
4. Remote Auto will override Local Auto and Remote Stop but not Local Stop

If an operator tries to start the unit from the Remote CLD after the Stop command has been given at the unit CLD, the screen on the Remote CLD will read:

"LOCAL STOP command at unit cannot be overridden by this remote device"

## Communication Failure

If a communication failure occurs between the Remote CLD and the unit's CLD, the setpoints will remain the same but a diagnostic will occur at the Remote CLD panel. The Remote display screen will read:

"No communication to Unit X"  
 Press (enter) to select new unit



# Pre-Start Checkout

---

## General

When installation is complete, but prior to putting the unit into service, the following pre-start procedures must be reviewed and verified correct:

- [ ] Inspect all wiring connections to be sure they are clean and tight.

---

**WARNING: Disconnect all electric power including remote disconnects before servicing. Failure to disconnect power before servicing can cause severe personal injury or death.**

---

**Caution: Check the tightness of all connections in the compressor power circuits (disconnects, terminal block, contactors, compressor junction box terminals, etc.). Loose connections can cause overheating at the connections and undervoltage conditions at the compressor motor.**

- [ ] Verify that all refrigerant valves, as shown in Figure 21, are "OPEN".

**Caution: Do not operate the unit with the compressor, oil discharge and liquid line service valves "CLOSED". Failure to have these "OPEN" may cause serious compressor damage.**

- [ ] Check the power supply voltage to the unit at the main power fused-disconnect switch. Voltage must be within the voltage utilization range, given in Tables 3 and also stamped on the unit nameplate. Voltage imbalance must not exceed 2 percent. Refer to "Unit Voltage Imbalance", below.

---

**WARNING: Disconnect all electric power including remote disconnects before servicing. Failure to disconnect power before servicing can cause severe personal injury or death.**

---

- [ ] Check the unit power phasing to be sure that it has been installed in an "ABC" sequence. Refer to "Unit Voltage Phasing."

---

**WARNING: It is imperative that L1-L2-L3 in the starter be connected in the A-B-C phase sequence to prevent equipment damage due to reverse rotation.**

---

- [ ] Check the condenser fans to be sure that they rotate freely in the fan openings and that each is securely attached to its fan motor shaft.

---

**WARNING: Disconnect all electric power including remote disconnects before servicing. Failure to disconnect power before servicing can cause severe personal injury or death.**

---

- [ ] Energize the compressor sump heaters by closing the unit main disconnects. If unit-mounted disconnects are used, they must also be closed. If the unit does not have the optional control power transformer, 115 VAC power must be field supplied to terminals 1TB3-1 AND 1TB3-2. Press the Stop key on the Clear Language Display.

**Caution: The compressor sump heaters must be energized for a minimum of 24 hours prior to unit operation, to prevent compressor damage caused by liquid refrigerant in the compressor at start-up.**

- [ ] Energize the evaporator heat tape.
- [ ] Fill the evaporator chilled water circuit. Refer to Table 1 for evaporator liquid capacities. Vent the system while it is being filled. Open the vent on the top of the evaporator during filling and close when filling is completed.

### Customer Note

The use of improperly treated or untreated water in this equipment may result in scaling, erosion, corrosion, algae or slime. The services of a qualified water treatment specialist should be engaged to determine what treatment, if any, is advisable. The Trane Company warranty specifically excludes liability of corrosion, erosion or deterioration of Trane equipment. Trane assumes no responsibilities for the results of the use of untreated or improperly treated water or saline or brackish water.

**Caution: Do not use untreated or improperly treated water. Equipment damage may occur.**

**Caution: Do not fill the water system unless the evaporator heat tapes have been energized.**

- [ ] Close the fused-disconnect switch(es) that supplies power to the chilled water pump starter.
- [ ] Start the chilled water pump to begin circulation of the chilled water. Inspect all piping for leakage and make any necessary repairs.
- [ ] With chilled water circulating through the system, adjust water flow and check water pressure drop through the evaporator. Refer to Figure 9.
- [ ] Adjust the chilled water flow switch (if installed) for proper operation.
- [ ] Prove Chilled Water Flow Interlock and External Auto/Stop as described in Interlock Wiring.
- [ ] Check and set, as required, all Clear Language Display Menu Items.
- [ ] Stop the chilled water pump.

## Unit Voltage Power Supply

Voltage to the unit must meet the criteria given in Table 3. Measure each leg of the supply voltage at the unit main power fused-disconnect. If the measured voltage on any leg is not within specified range, notify the supplier of the power and correct the situation before operating the unit.

**Caution: Inadequate voltage to the unit can cause control components to malfunction and shorten the life of relay contact, compressor motors and contactors.**

## Unit Voltage Imbalance

Excessive voltage imbalance between the phases of a three-phase system can cause motors to overheat and eventually fail. The maximum allowable imbalance is 2 percent. Voltage imbalance is determined using the following calculations.

$$\% \text{ Imbalance} = \frac{(V_x - V_{ave}) \times 100}{V_{ave}}$$

$$V_{ave} = (V_1 + V_2 + V_3) / 3$$

$V_x$  = phase with greatest difference from  $V_{ave}$  (without regard to sign)

For example, if the three measured voltages are 221, 230, and 227 volts, the average would be:

$$\frac{221 + 230 + 227}{3} = 226$$

The percentage of imbalance is then:

$$\frac{100(221 - 226)}{226} = 2.2\%$$

This exceeds the maximum allowable (2%) by 0.2 percent.

## Unit Voltage Phasing

### WARNING

IT IS IMPERATIVE THAT  
L1-L2-L3 IN THE STARTER  
BE CONNECTED IN THE A-B-C  
PHASE SEQUENCE TO PREVENT  
EQUIPMENT DAMAGE DUE TO  
REVERSE ROTATION

It is important that proper rotation of the compressors be established before the unit is started. Proper motor rotation requires confirmation of the electrical phase sequence of the power supply. The motor is internally connected for clockwise rotation with the incoming power supply phased A, B, C.

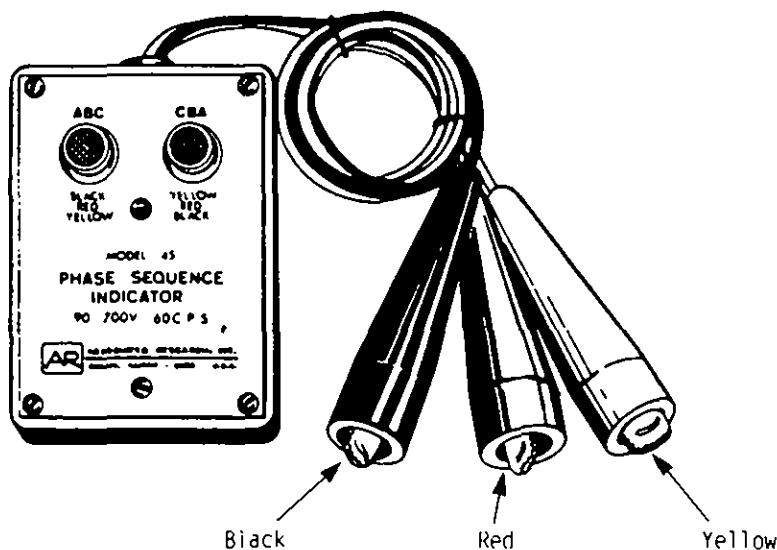
Basically, voltages generated in each phase of a polyphase alternator or circuit are called phase voltages. In a three phase

circuit, three sine wave voltages are generated, differing in phase by 120 electrical degrees. The order in which the three voltages of a three-phase system succeed one another is called phase sequence or phase rotation. This is determined by the direction of rotation of the alternator. When rotation is clockwise, phase sequence is usually called "ABC", when counterclockwise, "CBA".

This direction may be reversed outside the alternator by interchanging any two of the line wires. It is this possible interchange of wiring that makes a phase sequence indicator necessary if the operator is to quickly determine the phase rotation of the motor.

Proper compressor motor electrical phasing can be quickly determined and corrected before starting the unit. Use a quality instrument, such as the Associated Research Model 45 Phase Sequence Indicator shown in Figure 35, and follow this procedure.

**Figure 35**  
**Associated Research Model 45**  
**Phase Sequence Indicator**



1. Press the Stop key on the Clear Language Display.

2. Open the electrical disconnect or circuit protection switch that provides line power to the line power terminal block(s) in the starter panel (or to the unit-mounted disconnect).

3. Connect the phase sequence indicator leads to the line power terminal block, as follows:

<u>Phase Seq. Lead</u>	<u>Terminal</u>
Black (Phase A) .....	L1
Red (Phase B) .....	L2
Yellow (Phase C).....	L3

4. Turn power on by closing the unit supply power fuse disconnect switch.

5. Read the phase sequence on the indicator. The "ABC" LED on the face of the phase indicator will glow if phase is "ABC".

---

**WARNING! To prevent injury or death due to electrocution, take extreme care when performing service procedures with electrical power energized.**

---

6. If the "CBA" indicator glows instead, open the unit main power disconnect and switch two line leads on the line power terminal block(s) (or the unit mounted disconnect). Reclose the main power disconnect and recheck the phasing.

**Caution: Do not interchange any load leads that are from the unit contactors or the motor terminals.**

7. Reopen the unit disconnect and disconnect the phase indicator.

## Water System Flow Rates

Establish a balanced chilled water flow through the evaporator. The flow rates should fall between the minimum and maximum values given in Table 1. Chilled water flow rates below the minimum values will result in laminar flow, which reduces heat transfer and causes either loss of EXV control or repeated nuisance, low temperature cutouts. Flow rates that are too high can cause tube erosion and damage to the tube supports and baffles in the evaporator.

**Caution: Once the evaporator is filled with water, the evaporator heat tape must be energized to protect the evaporator from freezing and bursting if the outdoor air temperature drops below freezing.**

## Water System Pressure Drop

Measure chilled water pressure drop through the evaporator at the field-installed pressure taps on the system water piping. See Figure 8. Use the same gauge for each measurement. Do not include valves, strainers fittings in the pressure drop readings.

Pressure drop readings should be approximately those shown in the Pressure Drop Charts, Figure 9.

## Clear Language Display Set-up

Refer to "Clear Language Display Keypad Overview" for instruction on adjustment of the settings.

# Start-Up Procedures

## General

If the pre-start checkout, as discussed above, has been completed, the unit is ready to start. The Clear Language Display is shown in Figure 26 and Clear Language Display Sequence of Operation is shown in Figure 36. Complete each step, in sequence, as follows:

- [ ] Press the Stop key on the Clear Language Display.
- [ ] As necessary, adjust the setpoint values in the Clear Language Display menus, as describe in "Clear Language Display Key Pad Overview".
- [ ] Close the fused-disconnect switch for the chilled water pump. Energize the pump to start chilled water circulation.
- [ ] Check the service valves on the discharge line, suction line, oil line and liquid line for each circuit. These valves must be open (backseated) before starting the compressors.

**Caution: To prevent compressor damage, do not operate the unit until all refrigerant and oil line service valves are opened.**

- [ ] Energize the compressor sump heaters, if not already energized. Also close the unit-mounted disconnect, if used.

**Caution: The compressor sump heaters must be energized for a minimum of 24 hours prior to unit operation, to prevent compressor damage caused by liquid refrigerant in the compressor at start-up.**

- [ ] Verify that the evaporator heat tape is energized.
- [ ] Verify that the chilled water pump runs for one minute after the chiller is commanded to stop (for normal chilled water systems). See Interlock Wiring.
- [ ] Press the Auto key. If the chiller control calls for cooling and all safety interlocks are closed, the unit will start. The compressor(s) will load and unload in response to the temperature of the leaving chilled water temperature.

If optional low-ambient lockout is used, outside air temperature must be above the minimum starting ambients, as shown in Table 1, for continued unit operation. Also refer to the wiring diagrams in Figure 11.

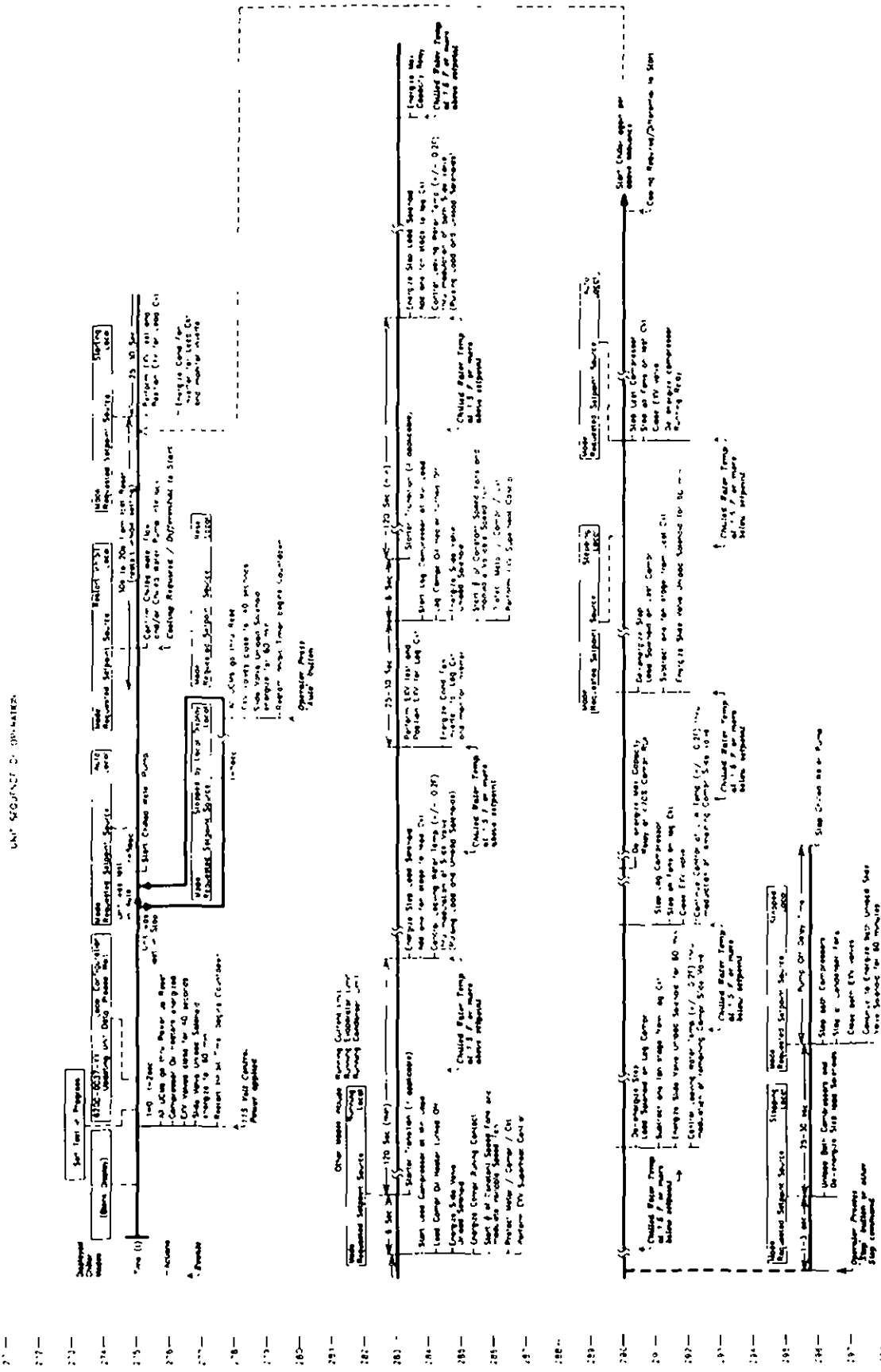
Once the system has been operating for approximately 30 minutes and has become stabilized, complete the start-up procedures, as follows:

- [ ] Check the evaporator refrigerant pressure and the condenser refrigerant pressure under Refrigerant Report on the Clear Language Display. The pressures are referenced to sea level (14.6960 psia).
- [ ] Check the liquid line sight glasses. The refrigerant flow past the sight glasses should be clear. Bubbles in the refrigerant indicate either low refrigerant charge or excessive pressure drop in the liquid line. A restriction in the line can sometimes be identified by a noticeable temperature differential between the two sides of the restriction. Frost may often form on the line at this point. Proper refrigerant charges are shown in Table 1.

**Caution: A clear sight glass alone does not mean that the system is properly charged. Also check system superheat, subcooling, and unit operating pressures.**



Figure 36  
Unit Sequence of Operation



- 
- [ ] Measure the system superheat. Refer to "System Superheat", below.
  - [ ] Measure the system subcooling. Refer to "System Subcooling", below.
  - [ ] A shortage of refrigerant is indicated if operating pressures are low and subcooling is also low. If the operating pressures, sight glass, superheat and subcooling readings indicate a refrigerant shortage, gas-charge refrigerant into each circuit, as required. With the unit running, add refrigerant vapor by connecting the charging line to the suction service valve and charging through the backseat port until operating conditions become normal.

**Caution: If both suction and discharge pressures are low but subcooling is normal, a problem other than refrigerant shortage exists. Do not add refrigerant, as this may result in overcharging the circuit.**

**Caution: Use only refrigerants specified on the unit nameplate, to prevent compressor damage and insure full system capacity.**

- [ ] If operating conditions indicate a refrigerant overcharge, remove refrigerant at the liquid line service valve. Allow refrigerant to escape slowly, to minimize oil loss. Do not discharge refrigerant into the atmosphere.

---

**WARNING: Do not allow refrigerant to directly contact skin or injury from frostbite may result.**

---

## System Superheat

Normal suction superheat for each circuit is approximately 4 F at full operating load. Superheat temperature can be expected to be moving around the 4 F setpoint when the chiller is pulling down, the compressor slide valve is being modulated, or the fans are staging on either the same or opposite circuits. Superheat can be expected to settle out at approximately 4 F when the above items stabilize.

## System Subcooling

Normal subcooling for each circuit ranges from 11 F to 20 F, depending on the unit. If subcooling for either circuit does not approximate these figures, check the superheat for the circuit and adjust, if required. If superheat is normal but subcooling is not, contact a qualified service technician.



# Unit Shutdown Procedures

## Temporary Shutdown and Restart

To shut the unit down for a short time, use the following procedure:

1. Press the Stop key on the Clear Language Display. The compressors will continue to operate and, after unloading for 20 seconds, will stop when the compressor contactors de-energize. The condenser fans will be de-energized at this time.
2. The unit disconnect switch and unit-mounted disconnect (if installed) should remain closed to keep the compressor sump heaters energized.
3. Maintain power to keep the evaporator heat tape energized
4. Stop the chilled water circulation by turning off the chilled water pump

To restart the unit after a temporary shutdown, restart the chilled water pump and press the AUTO key. The unit will start normally, provided the following conditions exist:

1. The UCM must receive a call for cooling and the differential to-start must be above the setpoint.
2. All system operating interlocks and safety circuits must be satisfied

3. Close all chilled water supply valves. Drain the chilled water from the evaporator. If the unit will be exposed to freezing ambient conditions, flush the evaporator with an antifreeze solution or energize the evaporator heat tape.

**Caution: To prevent damage to the evaporator by freezing, flush the evaporator with an antifreeze solution or energize the evaporator heat tape.**

4. Open the unit main electrical disconnect and unit-mounted disconnect (if installed) and lock on the "OPEN" position. If optional control power transformer is not installed, open and lock the 115 V disconnect

**Caution: Lock the disconnects on the "OPEN" position to prevent accidental start-up and damage to the system when it has been setup for extended shutdown.**

5. At least every three months (quarterly), check the pressure in the unit to verify that the refrigerant charge is intact

## Extended Shutdown Procedure

The following procedure is to be followed if the system is to be taken out of service for an extended period of time, eg., seasonal shutdown.

1. Test the unit for refrigerant leakage and repair as necessary.
2. Open the electrical disconnect switches for the chilled water pump. Lock the switch in the "OPEN" position.

**Caution: Lock the chilled water pump disconnect open to prevent pump damage.**

---

## System Restart After Extended Shutdown

Follow the procedures below to restart the unit after extended shutdown:

1. Verify that the liquid line service valves, oil line, compressor discharge service valves and suction service valves (if installed) are open (backseated).

**Caution: To prevent damage to the compressor, be sure that all refrigerant valves are open before starting the unit.**

2. Close the main disconnect and unit-mounted disconnect (if installed) to energize the compressor sump heaters. If the optional control transformer is not installed, it will be necessary to close the disconnect for 115 VAC power to 1TB3-1 and 1TB3-2.

**Caution: The compressor sump heaters must be energized for a minimum of 24 hours prior to unit operation, to prevent compressor damage caused by liquid refrigerant in the compressor at start-up.**

3. Maintain power to the evaporator heat tape connections.
4. Check the oil separator oil level. See "Oil Separator Level Check".

5. Fill the evaporator chilled water circuit. Refer to Table 1 for evaporator liquid capacities. Vent the system while it is being filled. Open the vent on the top of the evaporator during filling and close when filling is completed.

**Caution: Do not use untreated or improperly treated water. Equipment damage may occur.**

6. Close the fused-disconnect switch that provides power to the chilled water pump.
7. Start the chilled water pump and, while chilled water is circulating, inspect all piping for leakage. Make any necessary repairs before starting the unit.
8. While the chilled water is circulating, adjust the chilled water flow and check the chilled water pressure drop through the evaporator. Refer to "Water System Flow Rates" and "Water System Pressure Drop".
9. Adjust the flow switch on the evaporator piping (if installed) for proper operation.
10. Stop the chilled water pump. The unit is now ready for start-up as described in "Start-Up Procedures".

# Periodic Maintenance

## General

Perform all maintenance procedures and inspections at the recommended intervals. This will prolong the life of the equipment and minimize the possibility of costly failures.

Use an "Operator's Log", such as that shown in Figure 37, to record an operating history for the unit. The log serves as a valuable diagnostic tool for service personnel. By observing trends in operating conditions, an operator can anticipate and prevent problem situations before they occur.

If the unit does not operate properly during maintenance inspections, refer to "Diagnostics and Troubleshooting".

## Weekly Maintenance

After the unit has been operating for approximately 30 minutes and the system has stabilized, check the operating conditions and complete the procedures below:

- [ ] Check the evaporator refrigerant pressure and the condenser refrigerant pressure in the Refrigerant Report Menu on the Clear Language Display. The pressures are referenced to sea level (14.6960 psia).
- [ ] Check the liquid line sight glasses. The refrigerant flow past the sight glasses should be clear. Bubbles in the refrigerant indicate either low refrigerant charge or excessive pressure drop in the liquid line. A restriction in the line can sometimes be identified by a noticeable temperature differential between the two sides of the restriction. Frost may often form on the line at this point. Proper refrigerant charges are shown on Table 1.

**Caution: A clear sight glass alone does not mean that the system properly charged. Also check system superheat, subcooling, and unit operating pressures.**

- [ ] If operating pressures and sight glass conditions seem to indicate refrigerant shortage, measure the system superheat and system subcooling. Refer to "System Superheat" and "System Subcooling".

- [ ] If operating conditions indicate a refrigerant overcharge, remove refrigerant at the liquid line service valve. Allow refrigerant to escape slowly, to minimize oil loss. Do not discharge refrigerant into the atmosphere.

---

**WARNING: Do not allow refrigerant to directly contact skin or injury from frostbite may result.**

---

- [ ] Inspect the entire system for unusual conditions and inspect the condenser coils for dirt and debris. If the coils are dirty, refer to "Coil Cleaning".

## Monthly Maintenance

- [ ] Perform all weekly maintenance procedures.
- [ ] Measure and record the system superheat. Refer to "System Superheat".
- [ ] Measure and record the system subcooling. Refer to "System Subcooling".
- [ ] Manually rotate condenser fans to insure proper clearance on the fan openings.

---

**WARNING: Position all electrical disconnects in the "OPEN" position and lock them, to prevent injury or death due to electrical shock.**

---

## Annual Maintenance

- [ ] Perform all weekly and monthly maintenance procedures.
- [ ] Check the oil level and refrigerant charge. Refer to "Maintenance Procedures". Routine changing of oil is not required. See Oil Separator Level Check in the Maintenance section of this manual.

- [ ] Have a qualified laboratory perform a compressor oil analysis to determine system moisture content and acid level. This analysis is a valuable diagnostic tool.

- [ ] Contact a qualified service organization to leak test the chiller, to check operating and safety controls, and to inspect electrical components for deficiencies.

- [ ] Inspect all piping components for leakage and damage. Clean out any inline strainers.

- [ ] Clean and repaint any areas that show signs of corrosion.

- [ ] Clean the condenser coils. Refer to "Coil Cleaning".

---

**WARNING: Position all electrical disconnects in the "OPEN" position and lock them, to prevent injury or death due to electrical shock.**

---

- [ ] Clean the condenser fans. Check the fan assemblies for proper clearance in the fan openings and for motor shaft misalignment, abnormal end-play, vibration and noise.

---

**WARNING: Position all electrical disconnects in the "OPEN" position and lock them, to prevent injury or death due to electrical shock.**

---



**Figure 37  
Operator's Log**

RTAA 70 TO 125 TON DESIGN SEQUENCE "AO" AND LATER AIR COOLED SERIES R TEST LOG

Job Name				Elevation Above Sea Level				Ft.	
Job Location				S.O. No.					
Unit Model No.				Ship Date					
Unit Serial No. Nameplate Volt				Comp A Model No. Serial No. Nameplate RLA		Overload ON		Dipswitch OFF	
				Comp B Model No. Serial No. Nameplate RLA		Overload ON		Dipswitch OFF	
Evap H <sub>2</sub> O Pressure Drop		Design PSID		Actual PSID		Fan Motor RLA			
		Design GPM		Actual GPM		Heat Tape Volt			
Circuit			1	2	1	2	1	2	
Compressor			A	B	A	B	A	B	
Unit Voltage			PHASE A - B		A - C		B - C		
Compressor Amp			PHASE A		B		C		
Unit Operating Code									
Last Diagnostic									
Evap H <sub>2</sub> O Ent F									
Evap H <sub>2</sub> O Lvg F									
Outdoor Air Temp.									
Compressor Mxide									
Compressor Suction F									
Saturated Evap F									
Evap. Ref. Press. PSIG									
Saturated Cond F									
Cond. Ref. Press. PSIG									
Compressor % RLA									
% Line Volts									
Compressor Starts									
Compressor Hours									
Comments									

Owner	Svc Tech	Date
-------	----------	------

(Continued on reverse side)



**Figure 37**  
**Operator's Log**  
**(Continued from previous page)**

	Value
Setpoint Source	
Front Panel Chilled Wtr Setpt	
External Chilled Wtr Setpoint (d/E)	
Design Delta Temp Setpoint	
Differential To Start Setpoint	
Chilled Water Pump (On/Auto)	
Chilled Water Pump Off Delay	
Front Panel Current Limit Setpt	
External Current Limit Setpt (d/E)	
Low Ambient Lockout (d/E)	
Low Ambient Lockout Setpoint	
Chilled Water Reset Type	
[Type] Type, Reset Ratio	
[Type] Type, Start Reset Setpt	
[Type] Type, Max Reset Setpt	
Ice Machine Control (d/E)	
Panel Ice Termination Setpt	
Under/Over Voltage Protection (d/E)	
Unit Line Voltage	
Restart Inhibit Time	
Balanced CPRSR Starts & Hours (d/E)	
Display Units	
Programmable Relay Setup	
External Circuit Lockout (d/E)	
Keypad/Display Lock Feature (d/E)	
ICS Address	
Lvg Wtr Temp Cutout Setpoint	
Low Rfgr Temp Cutout Setpt	
Low Wtr Temp EXV Gain Comp	
Condenser Limit Setpoint	
Phase Unbalance Protection (d/E)	
Phase Reversal Protection (d/E)	
Superheat Setpoint	
EXV Control Response Ckt #1	
EXV Control Response Ckt #2	
Lvg Wtr Temp Ctrl Resp Setpt	
Fan Ctrl Deadband Bias, Ckt #1	
Fan Ctrl Deadband Bias, Ckt #2	
Compressor Mode No. Prefix	
Number of Compressors	
Oil Loss Differential Setpt	
Compressor A Tons	
Compressor B Tons	
Unit Model	
Fan Control	
Variable Speed Fan, Circuit #1	
Variable Speed Fan, Circuit #2	
Number of Fans, Circuit #1	
Number of Fans, Circuit #2	
Reduced Inrush Starting (d/E)	
Current Ovrld Setting, Cprsr A	
Current Ovrld Setting, Cprsr B	
Low Amb Unit, Half Airflow Fan (d/E)	
Low A+B Unit, Two Speed Motor (d/E)	
Night Noise Setback (d/E)	
Number of EXV Valves, Ckt #1	
Number of EXV Valves, Ckt #2	
Refrigerant Type	

# Maintenance

## General

This section describes specific maintenance procedures which must be performed as a part of the normal maintenance program for this unit. Be certain that electrical power to the unit is disconnected before performing these procedures.

**WARNING:** Position all electrical disconnects in the "OPEN" position and lock them, to prevent injury or death due to electrical shock.

## Coil Cleaning

Clean the condenser coils at least once each year, or more frequently if the unit is located in a "dirty" environment. This will maintain proper unit operating efficiencies. Follow the detergent manufacturer's instructions as closely as possible to avoid damage to the coils.

To clean the coils, use a soft brush and a sprayer, either the garden, pump-up type or a high-pressure type. A high-quality detergent, such as "Trane Coil Cleaner, CHM-0002" is recommended for both standard and "Blue-Fin" coils.

**Note:** If the detergent mixture is strongly alkaline (pH value greater than 8.5), an inhibitor must be added.

## Chemically Cleaning The Evaporator

The chilled water system is a closed-loop and therefore should not accumulate scale or sludge. If the chiller becomes fouled, first attempt to dislodge the material by backflushing the system. If unsuccessful after several attempts, chemically clean the evaporator.

**Caution:** Do not use an acid type cleaning agent that will damage steel, galvanized steel, polypropylene, or internal copper components.

With this information, water treatment firms will be able to recommend a suitable chemical for use in this system.

A typical configuration for chemical cleaning is shown in Figure 38. The supplier of the cleaning chemicals must provide or approve:

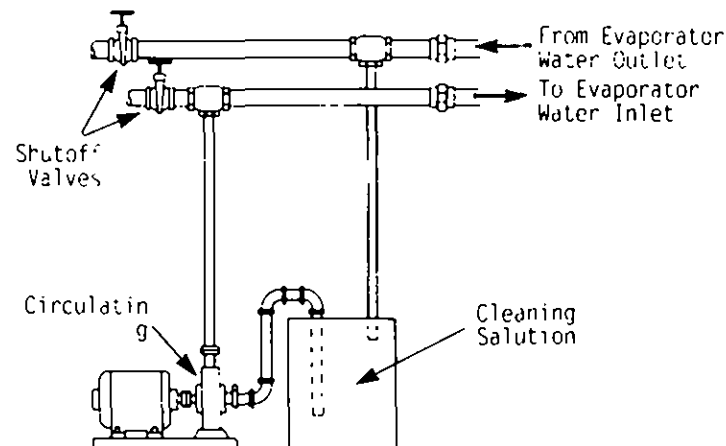
All of the materials used in this configuration

The amount of chemicals used

The length of time the chemicals are used

Any safety precautions and handling instructions

**Figure 38**  
**Chemical Cleaning Configuration**



## Water Treatment

The use of untreated or improperly treated water in the unit may result in the formation of scale, algae, or slime. It may also cause erosion or corrosion. It is recommended that a qualified water treatment specialist provide recommendations for proper water treatment. The Trane Company assumes no responsibility for equipment failure caused by the use of untreated or improperly treated water.

## Oil Separator Level Check

Follow the steps listed below and refer to the notes listed in Figure 39.

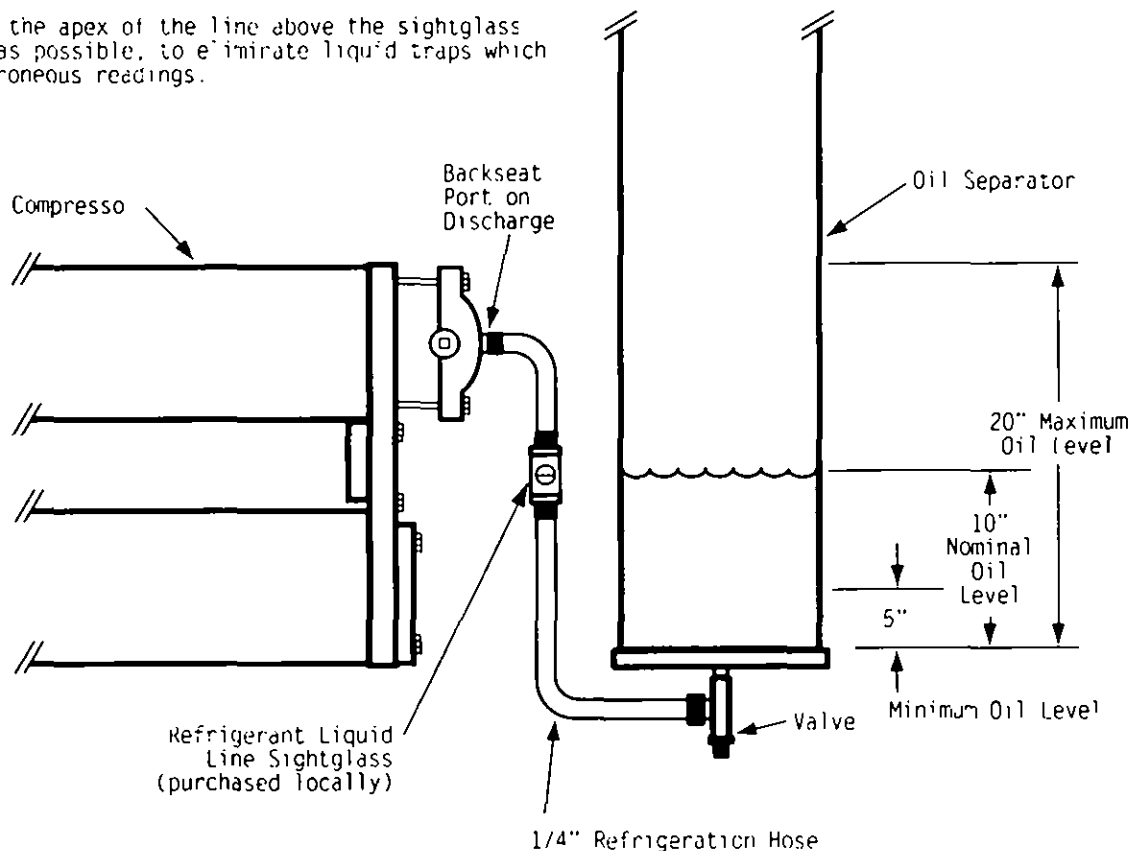
1. Turn off the unit.
2. Attach the hoses and sight glass to the oil separator charging Schrader valve and the compressor discharge service valve, as shown in Figure 39. Remove non-condensibles.

3. After the unit has been off for 10 minutes, move the sight glass up and down until the level can be seen.

4. After the level has been determined, remove the sight glass and hoses.

**Figure 39**  
**System Oil Level Specifications**

Insure that the apex of the line above the sightglass is as high as possible, to eliminate liquid traps which can give erroneous readings.



## Oil Filter Change

**Note:** Routine changing of the oil or the oil filter is not recommended. The oil filter is oversized for this application and should not require replacement.

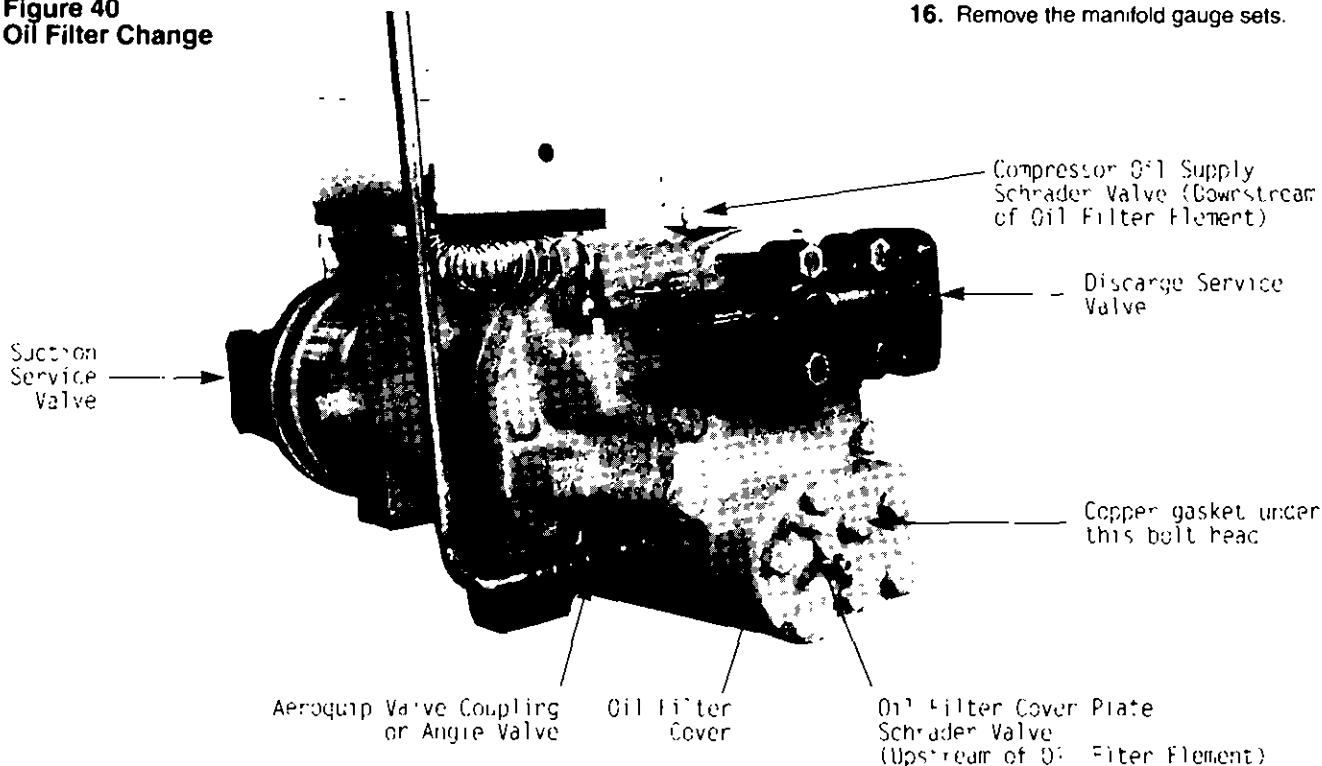
The oil and filter should be replaced only if analysis reveals that the oil is contaminated. Oil type and system capacities are shown in Table 1

Pressure drops across the oil filter is shown in Figure 41. Oil filter pressure drop is the difference between the pressure at the oil filter cover plate Schrader valve and the pressure at the compressor oil supply Schrader valve, on top of the compressor.

To change the oil filter in the unit, refer to Figure 40 and follow the steps listed below.

1. Shut off the compressor and disconnect all electrical service to the compressor.
2. Connect manifold gauge sets to the backseat ports of the suction and discharge service valves and the Schrader valve on the oil filter cover plate.

**Figure 40**  
Oil Filter Change



3. Frontseat the suction and discharge service valves. Separate the Aeroquip valve coupling at the oil supply to the compressor or, on later chillers, frontseat the oil supply line angle valve

4. Recover refrigerant from the three connections in Step 2.

**Note:** The Schrader valve may have a high quantity of oil.

**WARNING: Insure that pressure is relieved from oil filter before proceeding to step 5.**

5. Remove the seven bolts on the oil filter cover. A pan may be necessary to catch any oil that is released after the cover is loosened.

**Note:** Observe the placement of copper gasket under one bolt head.

6. Remove the cover and oil filter element.

7. Install the new filter element.

8. Coat the new cover gasket with refrigerant oil.

9. Install the cover plate and cover plate gasket.

10. Install a new copper gasket under the bolt head that had one at time of removal. Replace all other bolts and tighten to 150 ft. lbs

11. Energize the three solenoid valves on the compressor by jumpering the proper terminals at the UCM

12. Evacuate to 400 microns from the three ports in Step 2.

13. De-energize the three solenoid valves in Step 11.

14. Reconnect the Aeroquip coupling that was separated in Step 3 or, on later chillers, backseat the oil supply line angle valve.

**Caution: The Aeroquip valve must be completely tightened to open the valve. If the valve is not completely tightened, the valve may remain closed, causing catastrophic damage to the compressor.**

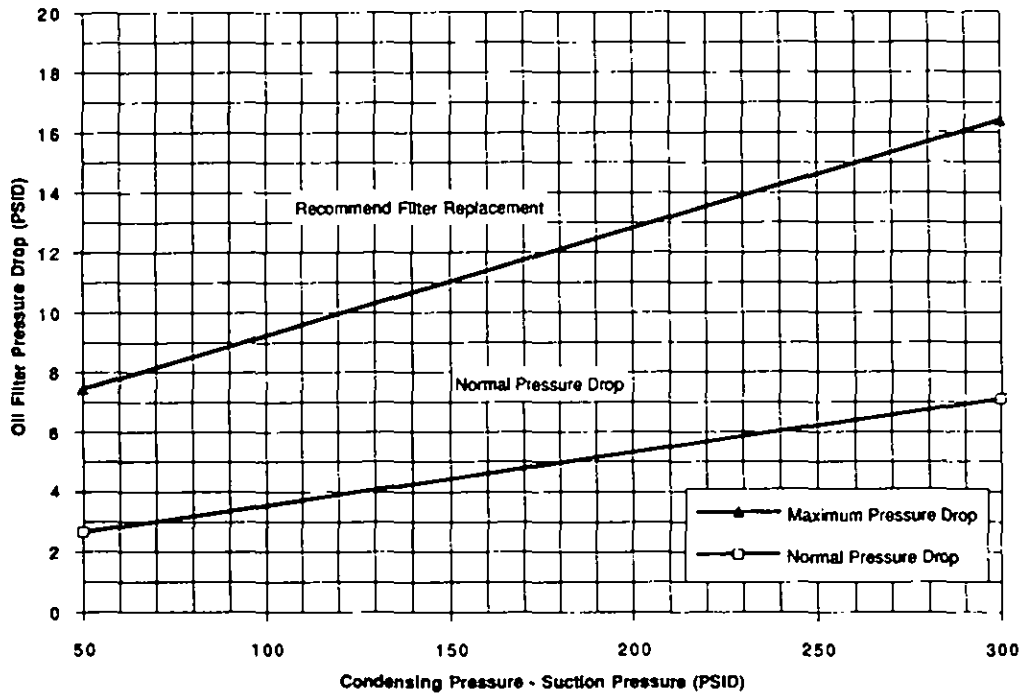
**Note:** Insure that this step is performed before Step 15, as this will insure that the oil filter housing is full of oil before the compressor is started.

15. Backseat the suction and discharge service valves

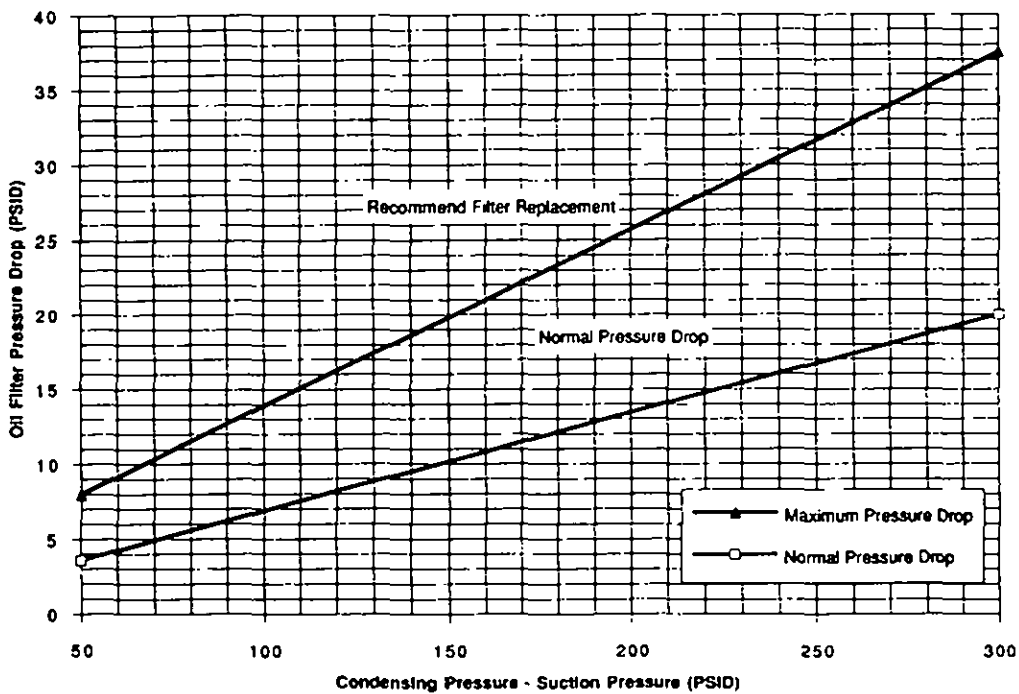
16. Remove the manifold gauge sets.

Figure 41  
Oil Pressure Drop

35 & 40 Ton Compressor Oil Filter Replacement Chart



50 & 60 Ton Compressor Oil Filter Replacement Chart



# Refrigerant Charging and Recovery

If the refrigerant charge needs to be adjusted, be certain to monitor the subcooling and superheat measurements. The subcooling needs to be between 10 F and 20 F when the unit is running fully loaded. The ambient temperature is between 75 F and 100 F and the leaving water temperature is between 40 F and 55 F. Refer to Figures 1, 2 and 21.

**Caution: The evaporator water flow must be established and maintained while adjusting the charge. Refrigerant pressures below 65 psig can cause freezing and rupturing of the evaporator tubes.**

## Low Side Repairs

If the refrigerant charge needs to be isolated in the high side of the unit, perform the following procedures:

1. Press the STOP key and send the unit through a stopping mode.
2. Place a manifold gauge set on the backseat port of the liquid line service valve before actually closing the valve.
3. Close the liquid line service valve
4. While the unit is in the STOP mode, enable Service Pumpdown for the specific compressor. Service Pumpdown is found under the Service Tests menu.

**Note:** Service Pumpdown can only be enabled for one compressor at a time. Only one pumpdown per compressor can be performed, until the unit has been reset. If these requirements are not met and Service Pumpdown is enabled, the screen will display "PROHIBITED" for one second and then return to disable.

With Service Pumpdown enabled, the Restart Inhibit will be ignored, the EXV will be prepositioned and the selected compressor will start and run for one minute.

5. Once the compressor stops, close the discharge service valve on the compressor.

6. The remaining refrigerant needs to be recovered from the suction service valve and the liquid line Schrader valve. Attach the inlet of a recovery system to the backseat port on the suction service valve and the Schrader valve between the liquid line service valve and the filter drier. Attach the outlet of the recovery system to the manifold gauge set that is already attached to the access port on the liquid line service valve. The condenser will be used as the storage vessel.

7. Complete all necessary repairs.

8. Evacuate out of the backseat port on the suction service valve and from the Schrader valve between the liquid line service valve and the filter drier.

9. Break the vacuum by adding refrigerant to the service port on the suction valve.

10. Open all valves, start the unit and verify the refrigerant charge by measuring the subcooling.

## High Side Repair

If the refrigerant needs to be isolated in the low side of the unit, perform the following procedures:

1. Press the STOP key and send the unit through a stopping mode.
2. Close the discharge service valve.
3. Before closing the liquid line service valve, attach a manifold gauge set to the liquid line valve backseat port
4. Close the liquid line service valve.
5. Attach the inlet of a liquid transfer pump to the manifold gauge set and the outlet to the 1/4" angle valve, located between the EXV and the evaporator. This will transfer the liquid refrigerant.
6. Remove the liquid transfer pump. Attach the inlet of a recovery system to the manifold gauge set and the outlet to the 1/4" angle valve, located between the EXV and the evaporator. Remove all of the vapor from the high side of the system.

7. Complete all necessary repairs.

8. Evacuate the high side through the access port on the liquid line service valve that has the manifold gauge set attached to it.

9. Open all of the valves and run the unit. Verify the refrigerant charge by measuring the subcooling and monitor the sightglass.

## Adding Refrigerant

If the entire charge has been removed, perform the following procedures to recharge the unit:

1. Open all service valves
2. Establish water flow through the evaporator. Connect a hose from the refrigerant bottle to the backseat port on the liquid line shutoff valve. Midseat the valve.

**Caution: The evaporator water flow needs to be established and maintained while adjusting the charge to avoid freezing and rupturing the tubes. Refrigerant pressure below 65 psig can also cause freezing and rupturing of the evaporator tubes.**

3. It may not be possible to put the entire amount of the refrigerant charge required using Step 2. If so, start the unit and add liquid refrigerant through the 1/4" liquid line angle valve between the EXV and the evaporator.
4. Once the unit has been charged with refrigerant, start the unit. Measure the subcooling and monitor the sightglass to verify that the refrigerant charge is correct.



# Unit Wiring

## General

Typical field connection diagrams, electrical schematics and connection diagrams for 70-125 Ton RTAA units of "AO" design sequence are shown on the following pages.

**Note:** The typical wiring diagrams in this manual are representative of "AO" design sequence units and are provided only for general reference. These diagrams may not reflect the actual wiring of your unit. For specific electrical connection and schematic information, always refer to the wiring diagrams which were shipped with your unit.

## Unit Electrical Data

To determine the specific electrical characteristics of a particular chiller, always refer to the nameplates mounted on the unit. See Figures 3 and 4.

Figure 42 Legend

LEGEND		
DEVICE DESIGNATION	DESCRIPTION	LINE NUMBER
171-3	FAN FUSES CRT #1	34-36
172-8	FAN FUSES CRT #2	37-39
1719	CONTROL CRT FUSE	125
1718,1717	CONTROL POWER TRANS FUSES	44-48
1718-20	INVERTER/AUTO-TRANS FUS FUSES CRT #1	63-65
1721-23	INVERTER/AUTO-TRANS FUS FUSES CRT #2	66-68
1K1,1K3	START CONTACTORS	151,152,153,141
1K2,1K6	RUN CONTACTORS	148,149
1K4,1K8	TRANSITION CONTACTORS	151,142
1K3,1K7	SHORTING CONTACTORS	152,143
1K9,10, 11,12	FAN CONTACTORS CRT #1	156-159
1K13,14 15,16	FAN CONTACTORS CRT #2	144-147
1R1-8	TRANSITION RECEPSTORS CRT #1	26,62,63,29-31
1R11-18	TRANSITION RECEPSTORS CRT #2	26,63,58,29-31
1S1	NON-FUSED DISCONNECT SWITCH	10
1S1	CONTROL POWER TRANSFORMER	158,164
1S2	INVERTER/AUTO VOLTAGE TRANSFORMER	44
173-3	OPRR CURRENT TRANS CRT #1	15,16,18,38,41,44
178-8	OPRR CURRENT TRANS CRT #2	26,27,30,49,52,55
179	C/D TRANSFORMER	185
1710	AUTO-TRANSFORMER CRT #1	63
1711	AUTO-TRANSFORMER CRT #2	66
1781	LINE VOLTAGE TERMINAL BLOCK	10
1783	TERMINAL STRIP 115V	
1788-8	TERMINAL STRIP 20V	
1U1	CHILLER MODULE	128,189
1U2	OPTIONS MODULE	172,233
1U3	EXP VALVE MODULE (OVR)	163,218
1J4	COMPRESSOR MODULE - OPFR A	20,208
1U4K1A	START RELAY OPFR A	151,153
1U4K1B	CRANKCASE HEATER RELAY OPFR A	142
1U4K1-47	FAN RELAYS CRT #1	142-158
1U4K2	TRANSITION RELAY OPFR A	151
1U5	COMPRESSOR MODULE-OPFR B	18,187
1U5K1A	START RELAY OPFR B	152
1U5K1B	CRANKCASE HEATER RELAY OPFR B	141
1U5K1-47	FAN RELAYS CRT #2	144-147
1U5K2	TRANSITION RELAY OPFR B	142
1U4010	SLIDE VALVE UNLOD CRT #1 (TRAC)	154
1U4012	SLIDE VALVE UNLOD CRT #1 (TRAC)	153
1U5010	SLIDE VALVE UNLOD CRT #2 (TRAC)	142
1U5012	SLIDE VALVE UNLOD CRT #2 (TRAC)	143
1U6	CLEAR LANGUAGE DISPLAY MODULE	187,188
1U7	REMOTE DISPLAY SUBTER MODULE	189,230
381	COMPRESSOR A CRT #1	16,41
482,3,4 5,8	FAN MOTORS CRT #1	83,80-88 98-102
4811,2	STEP LOAD SOLENOID CRT #1 (FIRST STEP)	152
4811,3	SLIDE VALVE LOAD SOLENOID CRT #1	154
4811,4	SLIDE VALVE UNLOD SOLENOID CRT #1	156
4815,1	HIGH PRESSURE SWITCH CRT #1	151
4815,2-4	WINDING THERMOSTATS CRT #1	158,159
481R1	CRANKCASE HEATER OPFR A	153
481R1,1	CRK OIL TEMP SENSOR CRT #1	217
481R1,3	OPFR SUC RPTC TEMP SENSOR CRT #1	222

LEGEND		
DEVICE DESIGNATION	DESCRIPTION	LINE NUMBER
481	COMPRESSOR A CRT #2	
482,3,4 5,8	FAN MOTORS CRT # 2	88,83-92 98-105
4811,6	STEP LOAD SOLENOID CRT #2 (FIRST STEP)	140
4811,6	SLIDE VALVE LOAD SOLENOID CRT #2	142
4811,7	SLIDE VALVE UNLOD SOLENOID CRT #2	143
4815,2	HIGH PRESSURE SWITCH CRT #2	150
4815,2-7	WINDING THERMOSTATS CRT #2	148,147
481R2	CRANKCASE HEATER OPFR B	141
481R2,1	CRK OIL TEMP SENSOR CRT #2	208
481R2,3	OPFR SUC RPTC TEMP SENSOR CRT #2	220
381	CHILLED WATER PUMP MOTOR	4
3K1	CHILLER WATER PUMP STARTER	6,136
3K2	ALARM RELAY	132
3K3	ALARM RELAY	133
3K4	UNIT RUNNING RELAY	134
3K5	SAFE CAPACITY SUBMIT RELAY	135
3K15	CRK CHILLED WTR SETPOINT RELAY	201
3K16	CRK CURRENT LIMIT SETPOINT RELAY	207
3K18	EMERGENCY STOP RELAY	194
3K20	ICE MAKING CONTROL RELAY	213
3K25	CRK CRK LOCKOUT RELAY - CRK1	208
3K26	CRK CRK LOCKOUT RELAY - CRK2	198
3K1	CRK CHILLED WATER SETPOINT RESISTOR	203
3K2	CRK CURRENT LIMIT SETPOINT RESISTOR	209
3S2	CHILLED WATER SYSTEM DEMAND SWITCH	8
681	ELECTRONIC EXPANSION VALVE CRT #1	225
682	ELECTRONIC EXPANSION VALVE CRT #2	226
683	HEAT TAPE	127
6W1	VARIABLE SPEED FAN MODULE CRT #1	64
6W10	VARIABLE SPEED FAN MODULE CRT #2	67
6T3	OUTDOOR AIR TEMPERATURE SENSOR	190
6T4	ZONE TEMP SENSOR	233
6T7	TEMP CRT WTR TEMP SENSOR	183
6T8	TEMP CRT WTR TEMP SENSOR	183
6R1,9	SA1 EVAP RPTC TEMP SENSOR CRT #1	220
6R1,10	SA1 EVAP RPTC TEMP SENSOR CRT #2	224
6R1,12	SA1 COND RPTC TEMP SENSOR CRT #1	217
6R1,13	SA1 COND RPTC TEMP SENSOR CRT #2	208
6R1,14	SUBCOOLED LIQUID TEMP SENSOR CRT #1	215
6R1,15	SUBCOOLED LIQUID TEMP SENSOR CRT #2	204
6S8	LOW PRESSURE SWITCH CRT #1	228
6S9	LOW PRESSURE SWITCH CRT #2	230

DEVICE PREPOT LOCATION CODE	
AREA	LOCATION
1	CONTROL PANEL
2	REMOTE EVAPORATOR
3	FIRST CIRCUIT COMP & FANS
4	SECOND CIRCUIT COMP & FANS
5	CUSTOMER PROVIDED
6	UNIT MOUNTED

**⚠ WARNING**

HAZARDOUS VOLTAGE!  
DISCONNECT ALL ELECTRIC POWER INCLUDING REMOTE DISCONNECTS BEFORE SERVICING  
FAILURE TO DISCONNECT POWER BEFORE SERVICING CAN CAUSE SEVERE PERSONAL INJURY OR DEATH

**⚠ AVERTISSEMENT**

VOLTAGE HASARDEUX!  
DECONNECTEZ TOUTES LES SOURCES ELECTRIQUES INCLUANT LES DISJONCTEURS SITUES A DISTANCE AVANT D'EFFECTUER L'ENTRETIEN  
FAUTE DE DECONNECTER LA SOURCE ELECTRIQUE AVANT D'EFFECTUER L'ENTRETIEN PEUT ENTRAENER DES BLESSURES CORPORELLES SEVERES OU LA MORT

**IMPORTANT**

USE COPPER CONDUCTORS ONLY TO PREVENT EQUIPMENT DAMAGE. UNIT TERMINALS ARE NOT DESIGNED TO ACCEPT ANY OTHER WIRING

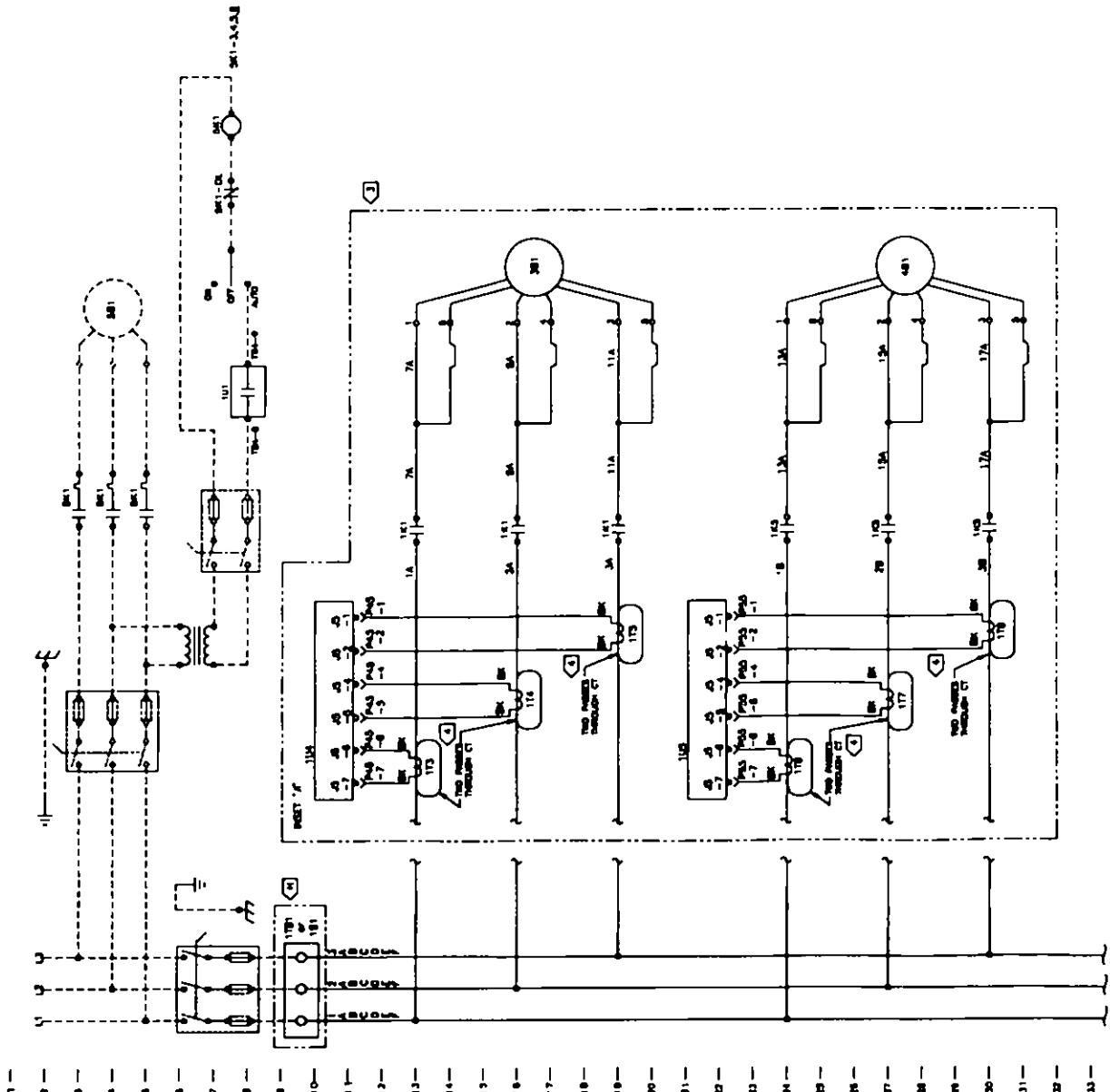
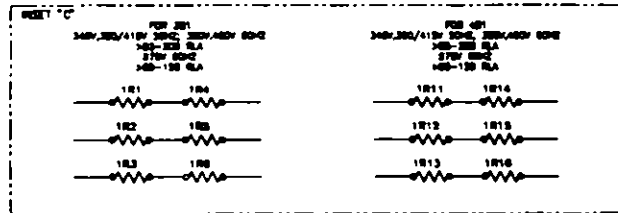
- NOTES:
- UNLESS OTHERWISE NOTED, ALL SWITCHES ARE SHOWN AT 25°C (77°F) AT ATMOSPHERIC PRESSURE. AT 50% RELATIVE HUMIDITY, WITH ALL UTILITIES TURNED OFF AND AFTER A NORMAL SHUTDOWN HAS OCCURRED.
  - DASHED LINES INDICATE RECOMMENDED FIELD WIRING BY OTHERS. DASHED LINE ENCLOSURES AND/OR DASHED DEVICE OUTLINES INDICATE COMPONENTS PROVIDED BY THE FILL PHANTOM LINE ENCLOSURES INDICATE ALTERNATE CIRCUITRY OR AVAILABLE SALES OPTIONS. SOLID LINES INDICATE WIRING BY TRADE CO.
  - NUMBERS ALONG THE RIGHT SIDE OF THE SCHEMATIC DENOTATE THE LOCATION OF CONTACTS BY LINE NUMBER. AN UNNUMBERED NUMBER INDICATES A NORMALLY CLOSED CONTACT. AN OPEN ARROWHEAD BELOW THE LINE NUMBER POINTING UPWARD INDICATES A TRIP CONTACT WHICH BECOMES TRIPping WHEN ENERGIZED.

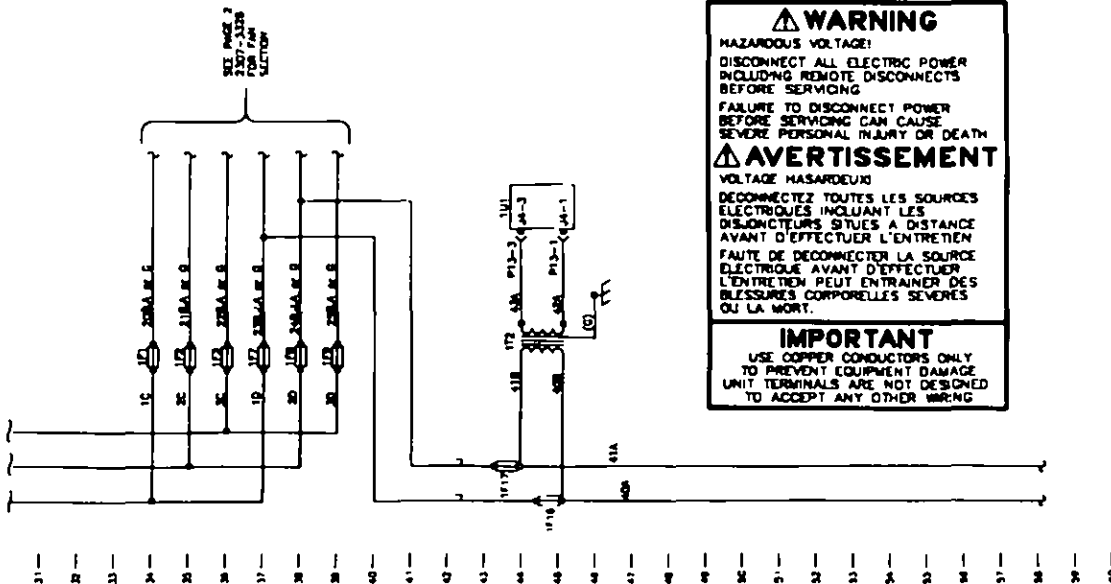
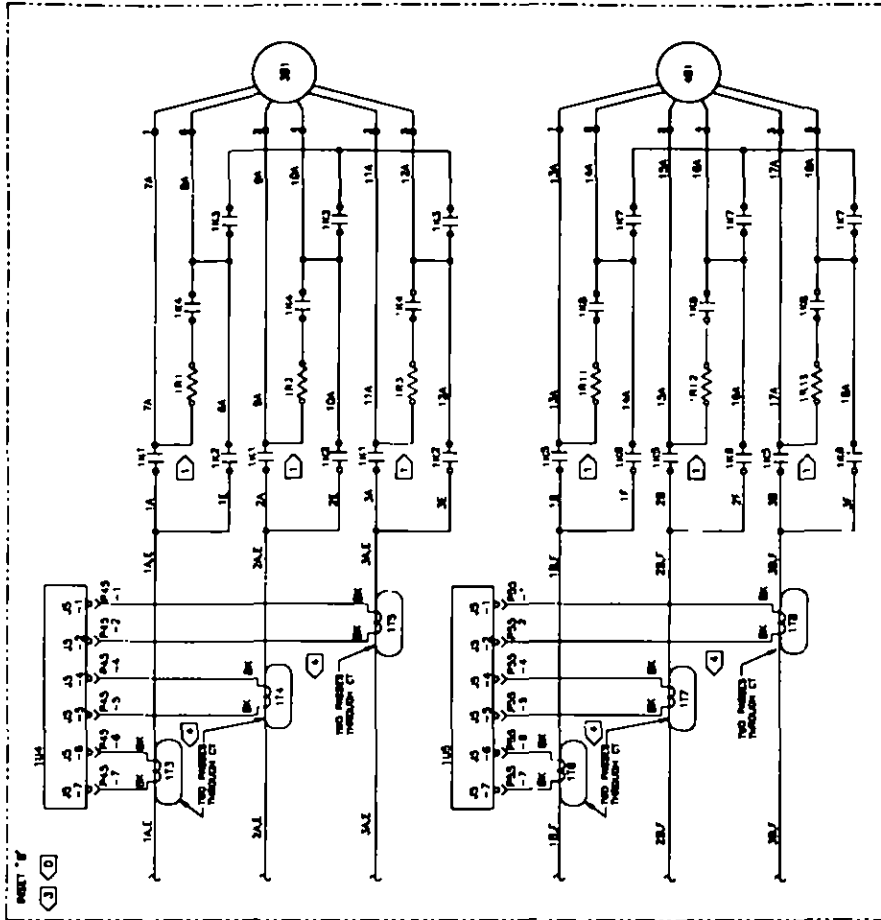


Figure 43  
Schematic Wiring

(Continued on  
next Page)

- NOTES
- 1 RESISTOR SHOWN FOR 200/230V 60HZ AND >275-400 FLA FOR OTHER VOLTAGES AND FLA SEE RESET "C".
  - 2 THE FOLLOWING CAPABILITIES ARE OPTIONAL. RESISTOR CONFIGURATIONS SHOWN ARE TYPICAL. CONFIGURATIONS MAY VARY BY UNIT VOLTAGE AND STARTER MANUFACTURER. THEY ARE REPLACED AND WIRED AS REQUIRED FOR A SPECIFIC SYSTEM APPLICATION.
    - (H) UNIT DISCONNECT NON-FUSED
    - (D) WYE-DELTA CLOSED TRANSITION STARTER
  - 3 SEE INSET "B" FOR WYE-DELTA CLOSED TRANSITION STARTER WIRING.
  - 4 575V UNITS REQUIRE TWO PHASES THROUGH CURRENT TRANSFORMERS. ALL OTHER VOLTAGES REQUIRE ONE PHAS THRU CURRENT TRANSFORMER.
  5. SEE ALSO STANDARD NOTES ON LEGEND DIAGRAM.





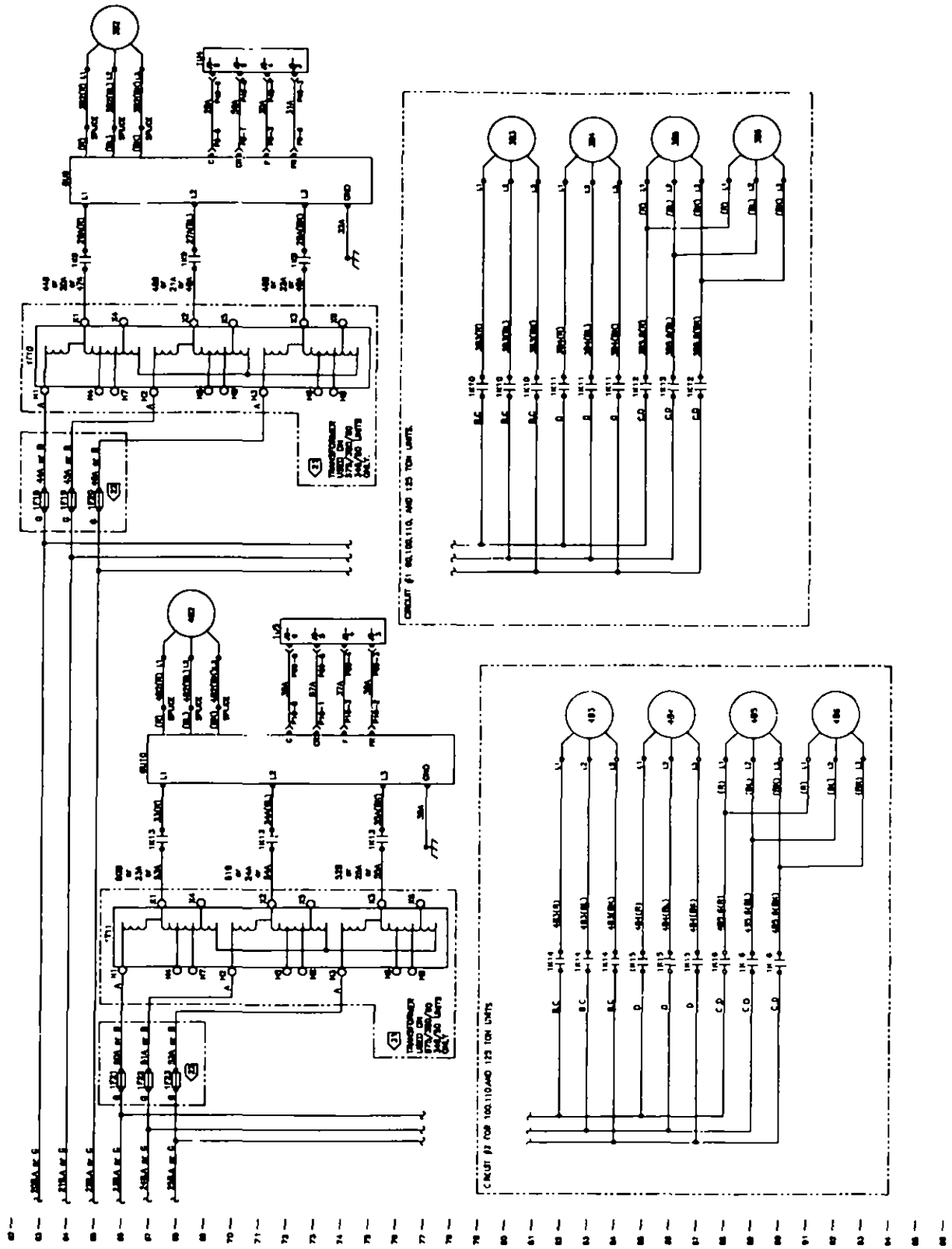
**⚠ WARNING**  
 HAZARDOUS VOLTAGE!  
 DISCONNECT ALL ELECTRIC POWER INCLUDING REMOTE DISCONNECTS BEFORE SERVICING  
 FAILURE TO DISCONNECT POWER BEFORE SERVICING CAN CAUSE SEVERE PERSONAL INJURY OR DEATH

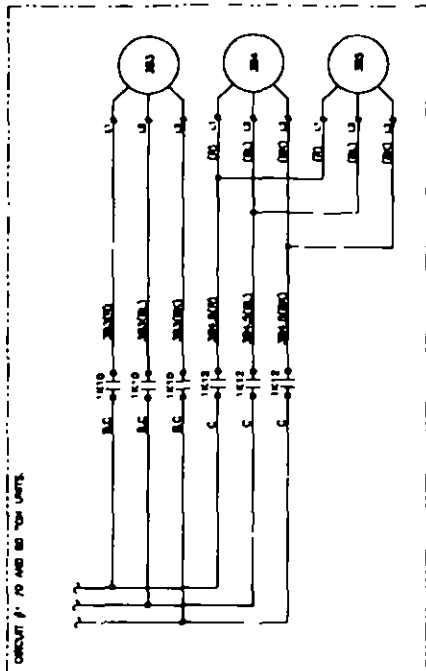
**⚠ AVERTISSEMENT**  
 VOLTAGE HASARDEUX!  
 DECONNECTEZ TOUTES LES SOURCES ELECTRIQUES INCLUANT LES DISCONNECTS SITUES A DISTANCE AVANT D'EFFECTUER L'ENTRETIEN  
 FAUTE DE DECONNECTER LA SOURCE ELECTRIQUE AVANT D'EFFECTUER L'ENTRETIEN PEUT ENTRAINER DES BLESSURES CORPORELLES SEVERES OU LA MORT.

**IMPORTANT**  
 USE COPPER CONDUCTORS ONLY TO PREVENT EQUIPMENT DAMAGE  
 UNIT TERMINALS ARE NOT DESIGNED TO ACCEPT ANY OTHER WIRING

Figure 44  
Schematic Wiring  
(Continued)

(Continued on  
next page)

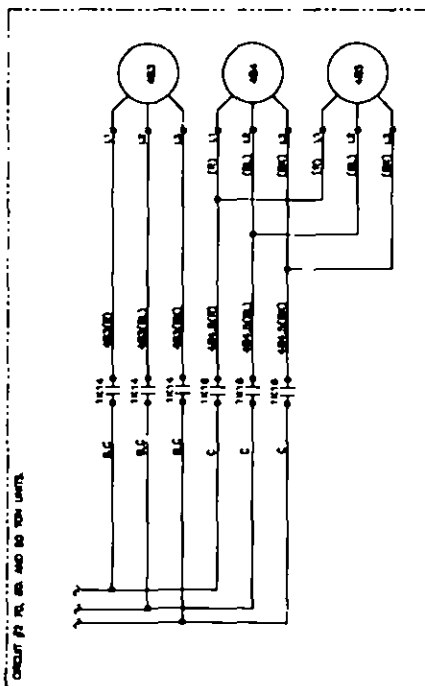




CIRCUIT 70 AND 80 FOR UNITS

1. UNIT IS SUPPOSED WIRING FOR 200, 201, AND 202 UNITS. PRIMARY TERMINALS 1A, 1B, 1C, 1D, 1E, 1F, 1G, 1H, 1I, 1J, 1K, AND 1L ARE USED AND SECONDARY TERMINALS 21, 22, 23 ARE USED FOR 200 UNITS. PRIMARY TERMINALS 17, 18, 19 ARE USED AND SECONDARY TERMINALS 31, 32, 33 ARE USED.

2. FUSES 1116-23 USED ON ALL UNITS EXCEPT 200/230 VOLT.



CIRCUIT 72 FOR UNITS 200, 201, AND 202

<p><b>⚠ WARNING</b></p> <p>HAZARDOUS VOLTAGE DISCONNECT ALL ELECTRIC POWER INCLUDING REMOTE DISCONNECTS BEFORE SERVICING FAILURE TO DISCONNECT POWER BEFORE SERVICING CAN CAUSE SEVERE PERSONAL INJURY OR DEATH</p> <p><b>⚠ AVERTISSEMENT</b></p> <p>VOLTAGE HAZARDEUX DECONNECTEZ TOUTES LES SOURCES ELECTRIQUES INCLUANT LES DISCONNECTEURS SITUES A DISTANCE AVANT D'EXECUTER L'ENTRETIEN FAUTE DE DECONNECTER LA SOURCE ELECTRIQUE AVANT D'EXECUTER L'ENTRETIEN PEUT ENTRAINER DES BLESSURES CORPORELLES SEVERES OU LA MORT.</p> <p><b>IMPORTANT</b></p> <p>USE COPPER CONDUCTORS ONLY TO PREVENT EQUIPMENT DAMAGE. UNIT TERMINALS ARE NOT DESIGNED TO ACCEPT ANY OTHER WIRING.</p>
---

1 2 3 4 5 6 7 8 9 10 11 12 13 14 15 16 17 18 19 20

Figure 45  
Schematic Wiring  
(Continued)

(Continued on  
next page)

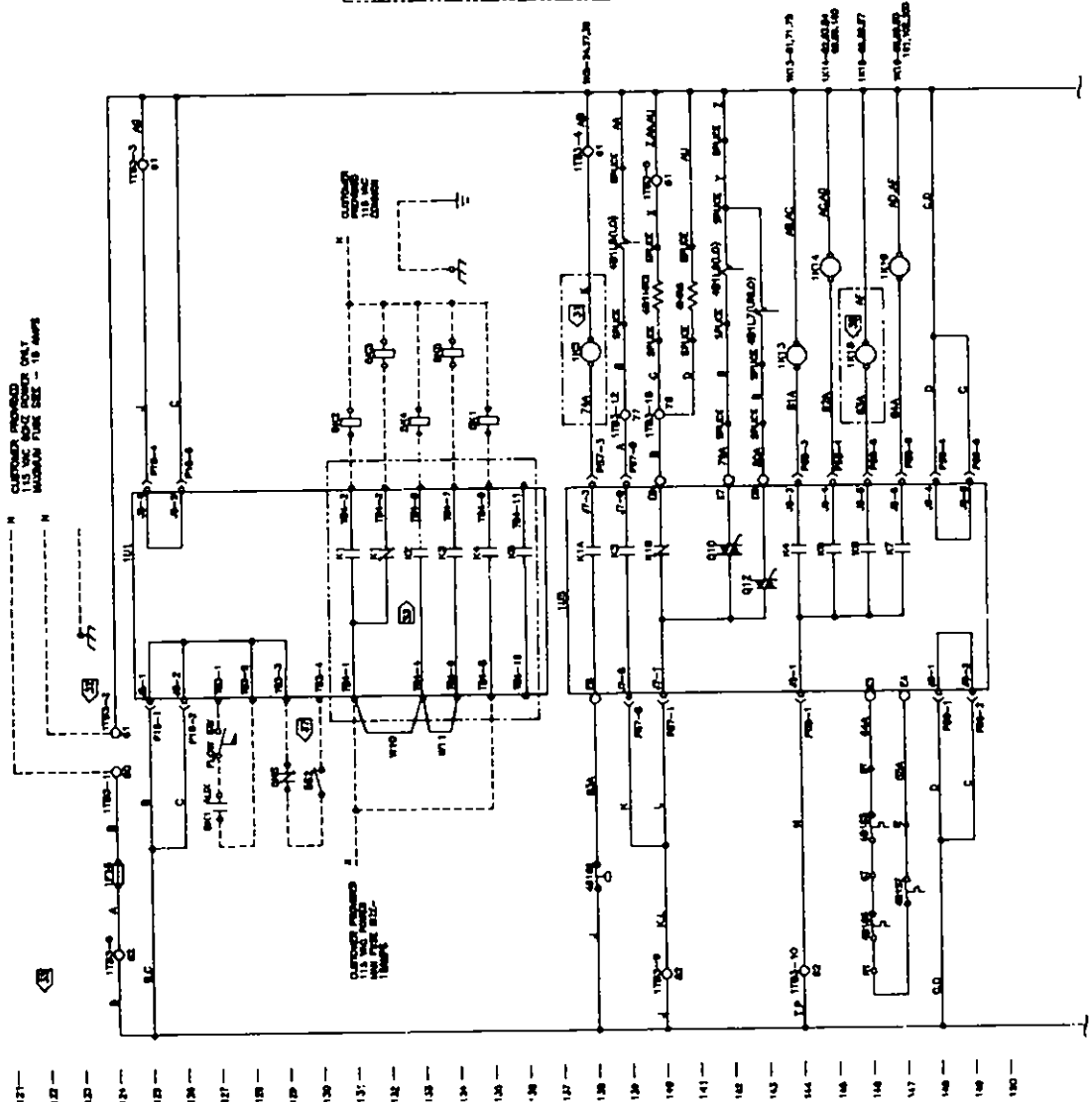
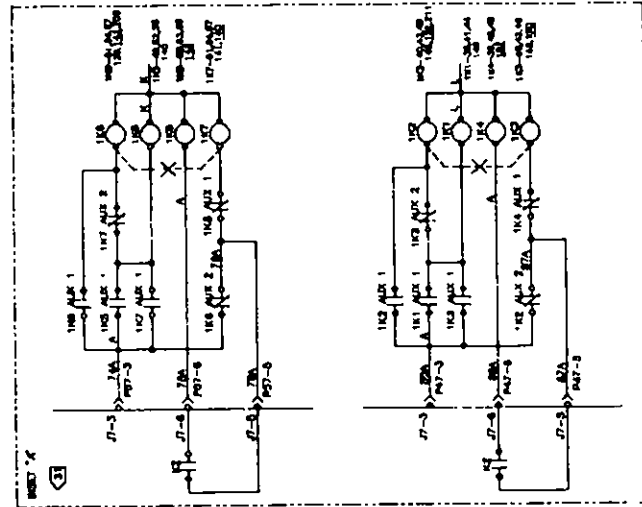
**⚠ WARNING**  
HAZARDOUS VOLTAGE  
DISCONNECT ALL ELECTRIC POWER  
INCLUDING REMOTE DISCONNECTS  
BEFORE SERVICING.

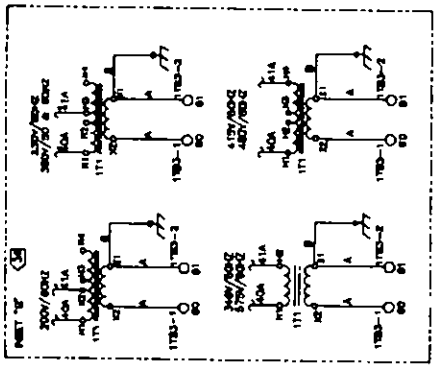
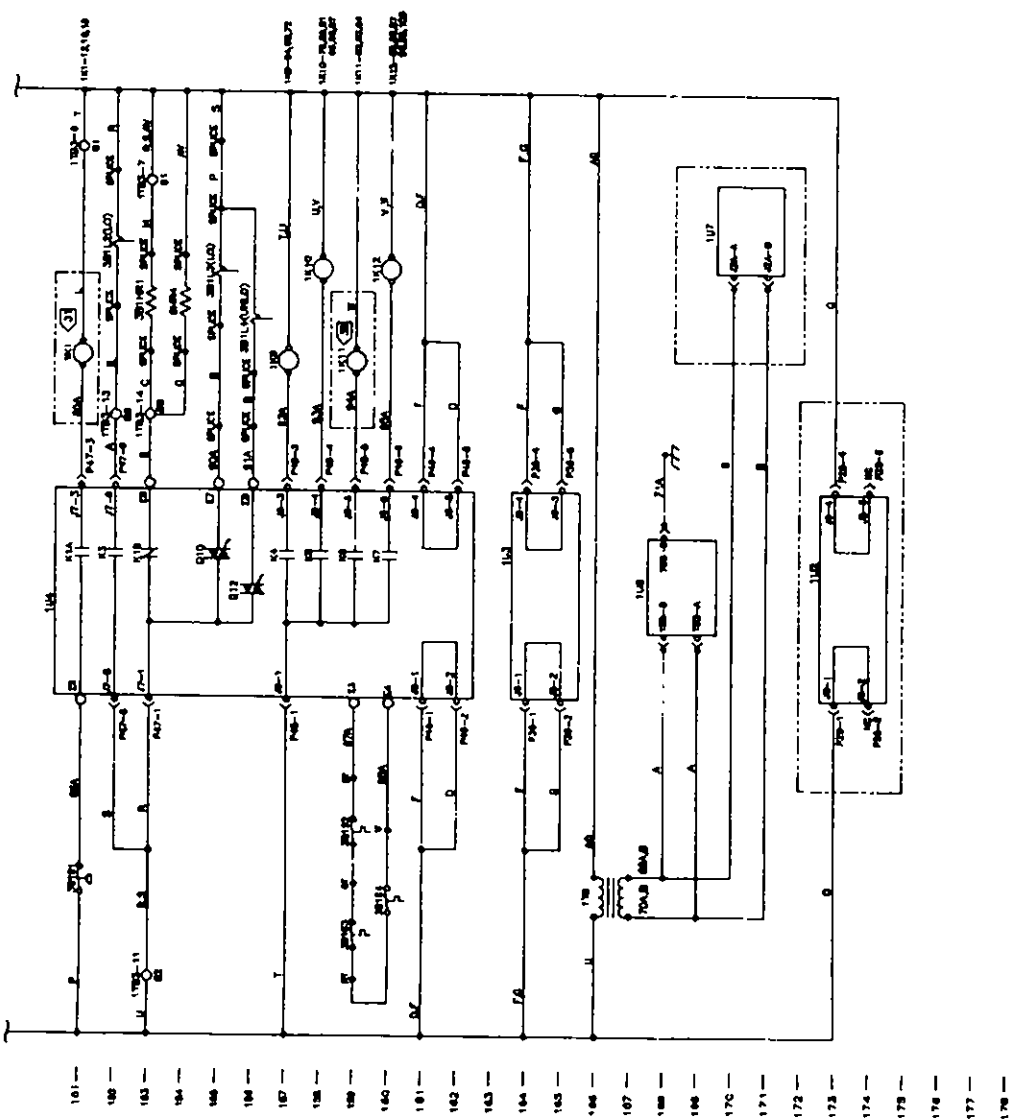
FAILURE TO DISCONNECT POWER  
BEFORE SERVICING CAN CAUSE  
SEVERE PERSONAL INJURY OR DEATH.

**⚠ AVERTISSEMENT**  
VOLTAGE HASARDEUX  
DECONNECTEZ TOUTES LES SOURCES  
ELECTRIQUES INCLUANT LES  
DISJONCTEURS SITUES A DISTANCE  
AVANT D'EFFECTUER L'ENTRETIEN

FAUTE DE DECONNECTER LA SOURCE  
ELECTRIQUE AVANT D'EFFECTUER  
L'ENTRETIEN PEUT ENTRAINER DES  
BLESSURES CORPORELLES SEVERES  
OU LA MORT.

**IMPORTANT**  
USE COPPER CONDUCTORS ONLY  
TO PREVENT EQUIPMENT DAMAGE.  
UNIT TERMINALS ARE NOT DESIGNED  
TO ACCEPT ANY OTHER WIRING





- NOTES
- 1. STARTER SHOWN SEE NOTE 'A' FOR WIRING IN CLOSED THROTTLE STARTER.
  - 2. FOR 30 HP UNITS REPLACE THE CONTROL POWER TRANSFORMER (117) WITH THE CUSTOMER MUST PROVIDE CONTROL POWER TRANSFORMER WITH THE SAME RATIO AS THE CONTROL POWER TRANSFORMER (117) IS PROVIDED ON 42 LATS. SEE NOTE 'F' FOR CONTROL TRANSFORMER DATA.
  - 3. RELAY COILS NOT SHOWN. CONTACTS ARE CONTROLLED BY THE LOGIC OF THE MICRO MODULE (117). THE 1183-3 RELAY OUTPUT CAN BE PROGRAMMED TO PERFORM ADVANCE FUNCTIONS. SEE INSTALLATION, OPERATION, AND MAINTENANCE MANUAL FOR DETAILS.
  - 4. IN ACTUAL PANEL LAYOUT ALL 1183-4 CONNECTIONS TO MODULES APPEAR ON THE REAR-HAND-SIDE OF THE MODULE.
  - 5. 200/50A CIRCUIT BREAKER IS FACTORY CONNECTED AS SHOWN. OTHER BREAKERS MUST BE APPROVED AS SHOWN IN NOTE 'A'.
  - 6. THE CUSTOMER AUTO/STOP BREAK IS FOR A CUSTOMER PROVIDED CUSTOMER STARTING AUTO/STOP START BREAK. AT THE CLOCK, BEFORE THIS BREAK IS CLOSED, THE CUSTOMER MUST PROVIDE AN EXTERNAL STOP CONTROL. THIS CONTROL IS USED TO STOP THE SYSTEM (EXTERNAL STOP) IS CONNECTED TO THE LOGIC EXTENSION AUTO/STOP INPUT.
  - 7. NOT USED ON 70, 80 AND 90 TON UNITS.
  - 8. NOT USED ON 70 AND 80 TON UNITS.

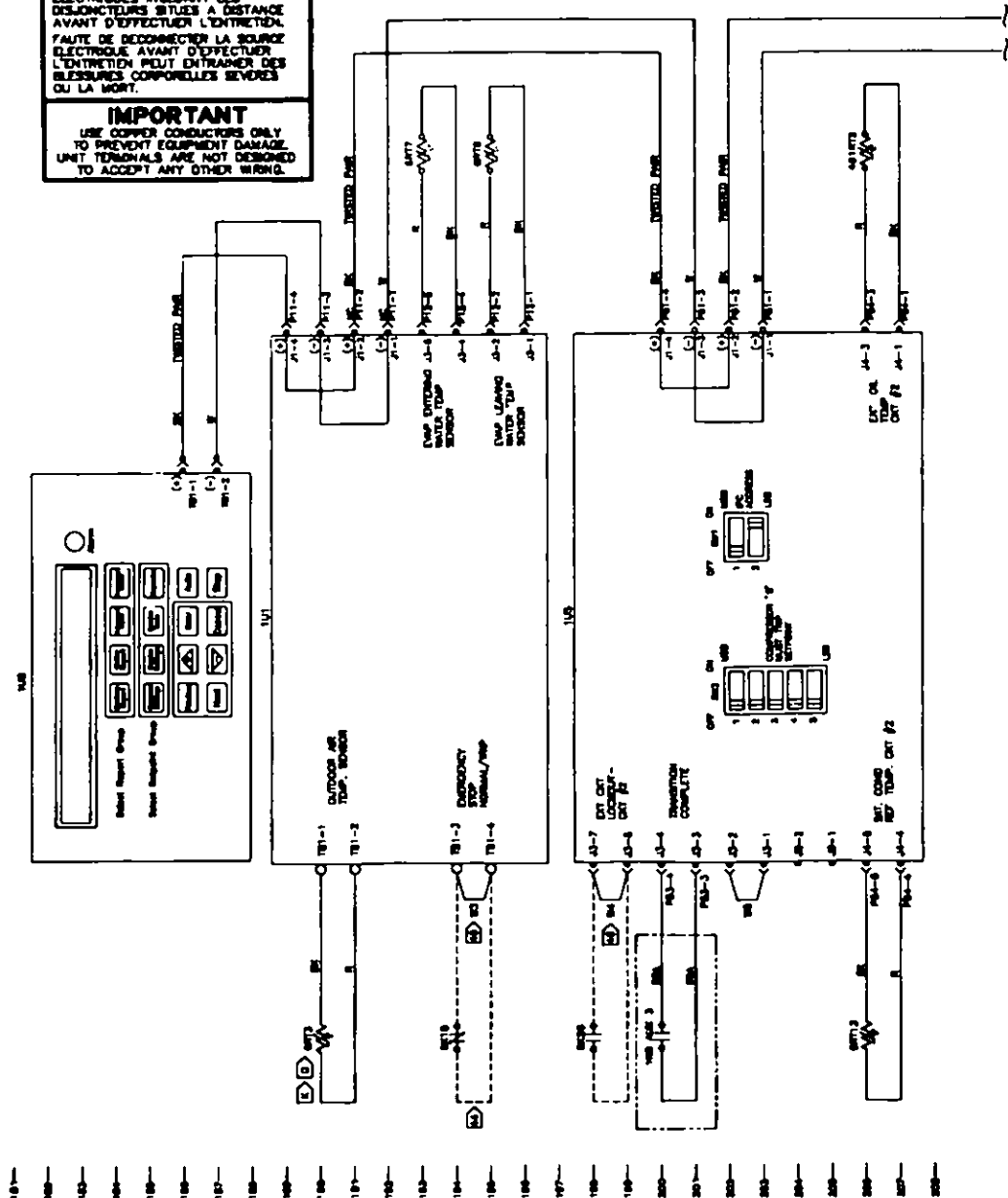
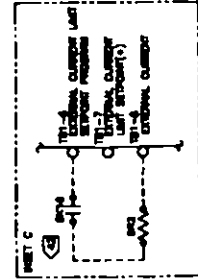
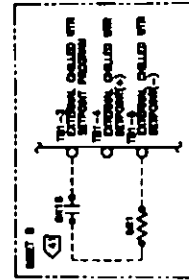
Figure 46  
Schematic Wiring  
(Continued)

(Continued on next page)

**⚠ WARNING**  
HAZARDOUS VOLTAGE  
DISCONNECT ALL ELECTRIC POWER INCLUDING REMOTE DISCONNECTS BEFORE SERVICING.  
FAILURE TO DISCONNECT POWER BEFORE SERVICING CAN CAUSE SEVERE PERSONAL INJURY OR DEATH.

**⚠ AVERTISSEMENT**  
VOLTAGE HASARDEUX  
DECONNECTEZ TOUTES LES SOURCES ELECTRIQUES INCLUANT LES DISCONNECTEURS SITUES A DISTANCE AVANT D'EFFECTUER L'ENTRETIEN.  
FAUTE DE DECONNECTER LA SOURCE ELECTRIQUE AVANT D'EFFECTUER L'ENTRETIEN PEUT ENTRAINER DES BLESSURES CORPORELLES SEVERES OU LA MORT.

**IMPORTANT**  
USE COPPER CONDUCTORS ONLY TO PREVENT EQUIPMENT DAMAGE. UNIT TERMINALS ARE NOT DESIGNED TO ACCEPT ANY OTHER WIRING.



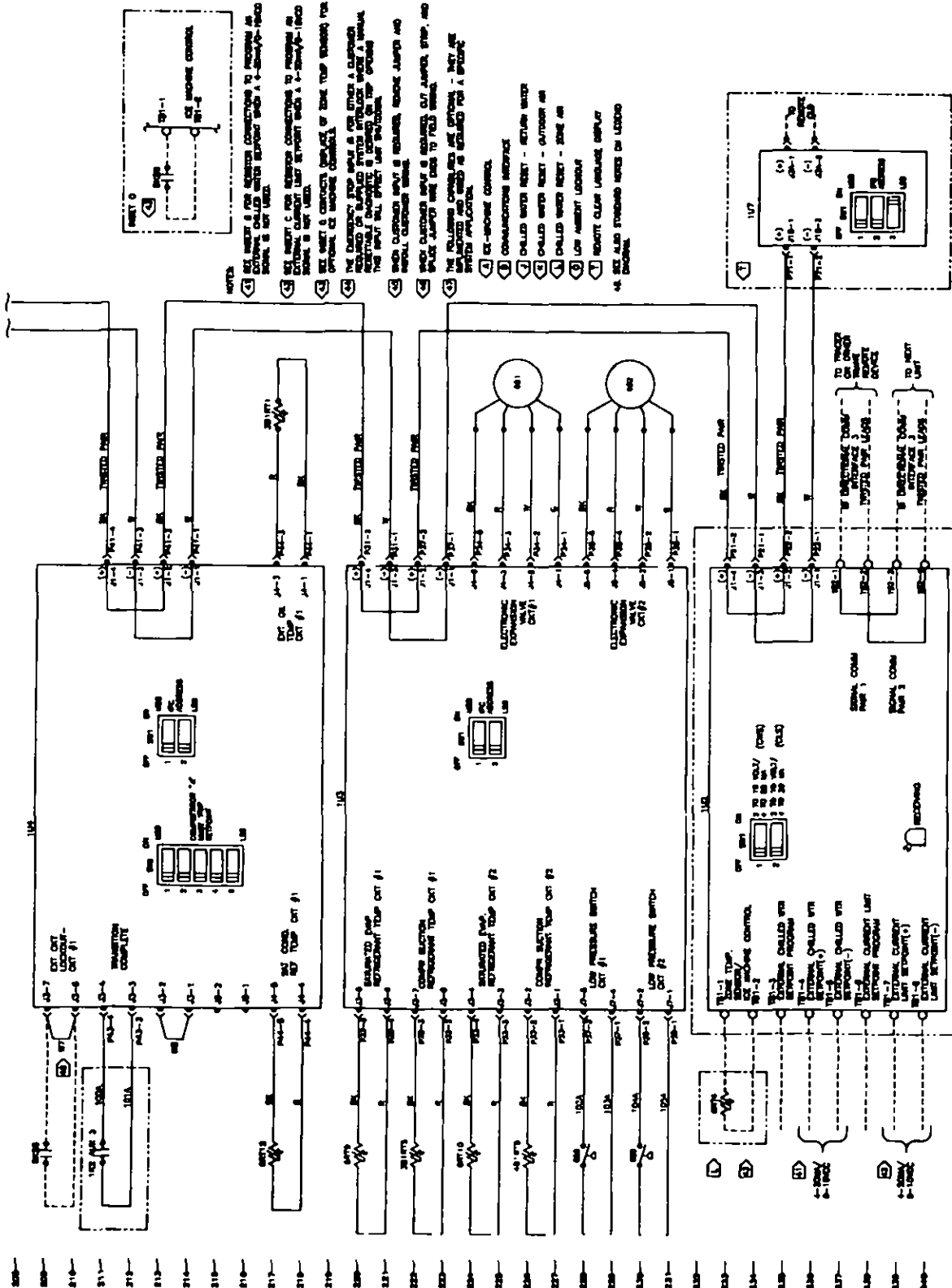
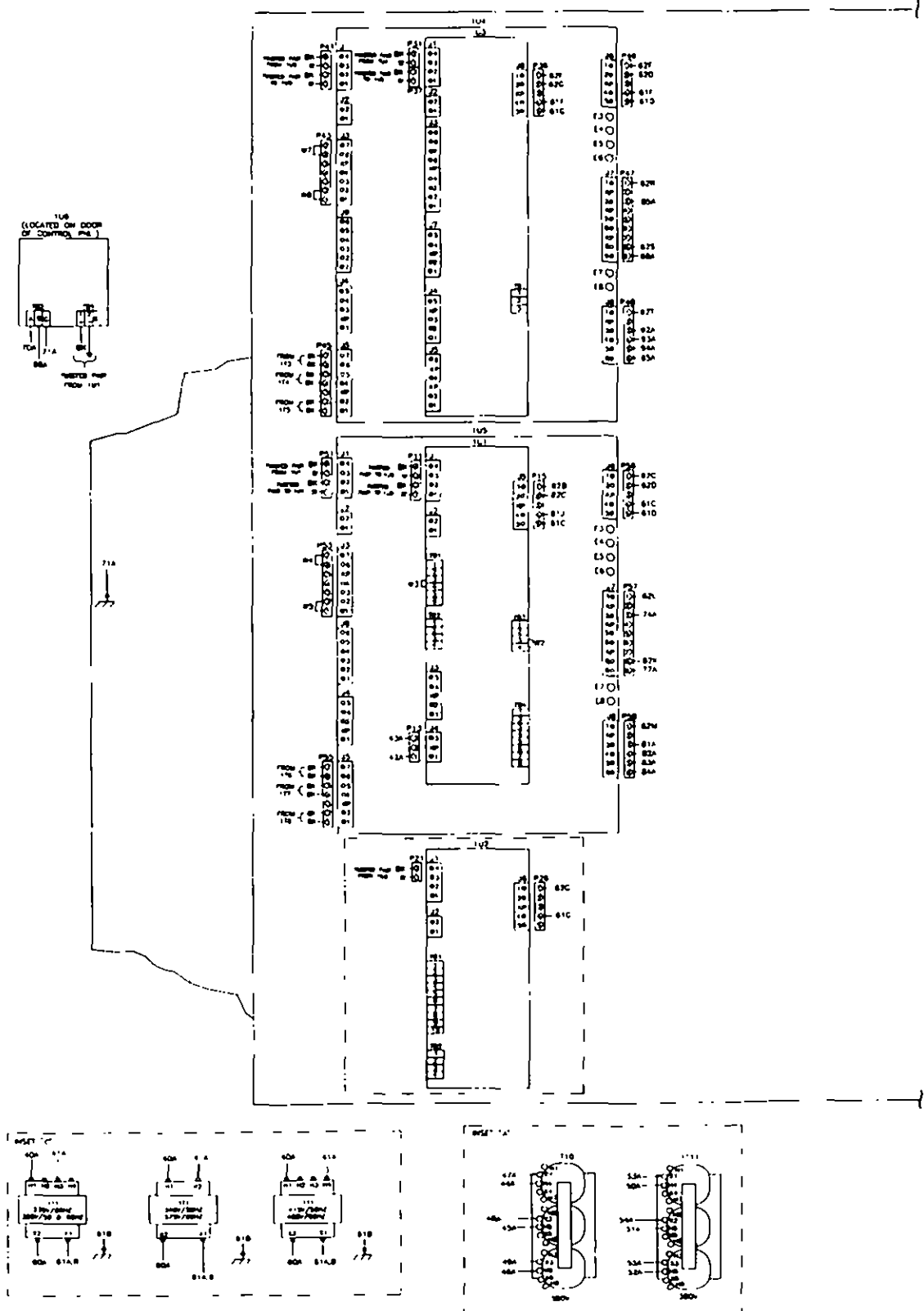
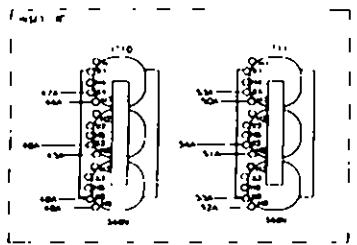
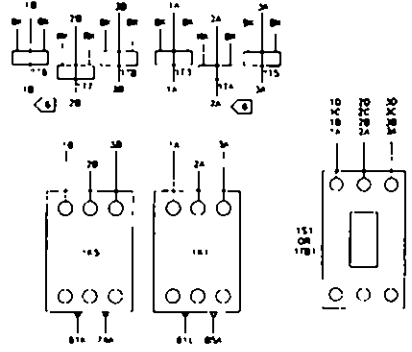
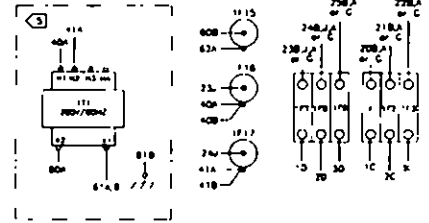
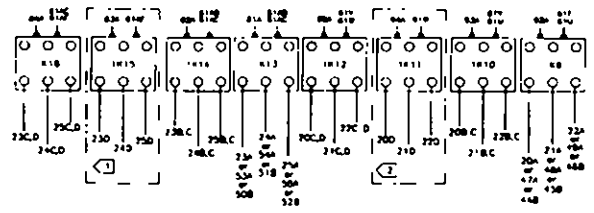
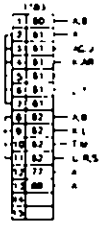
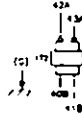
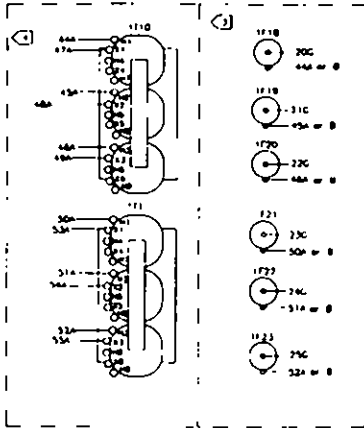




Figure 47  
 Connection Wiring, X-Line

(Continued on next page)

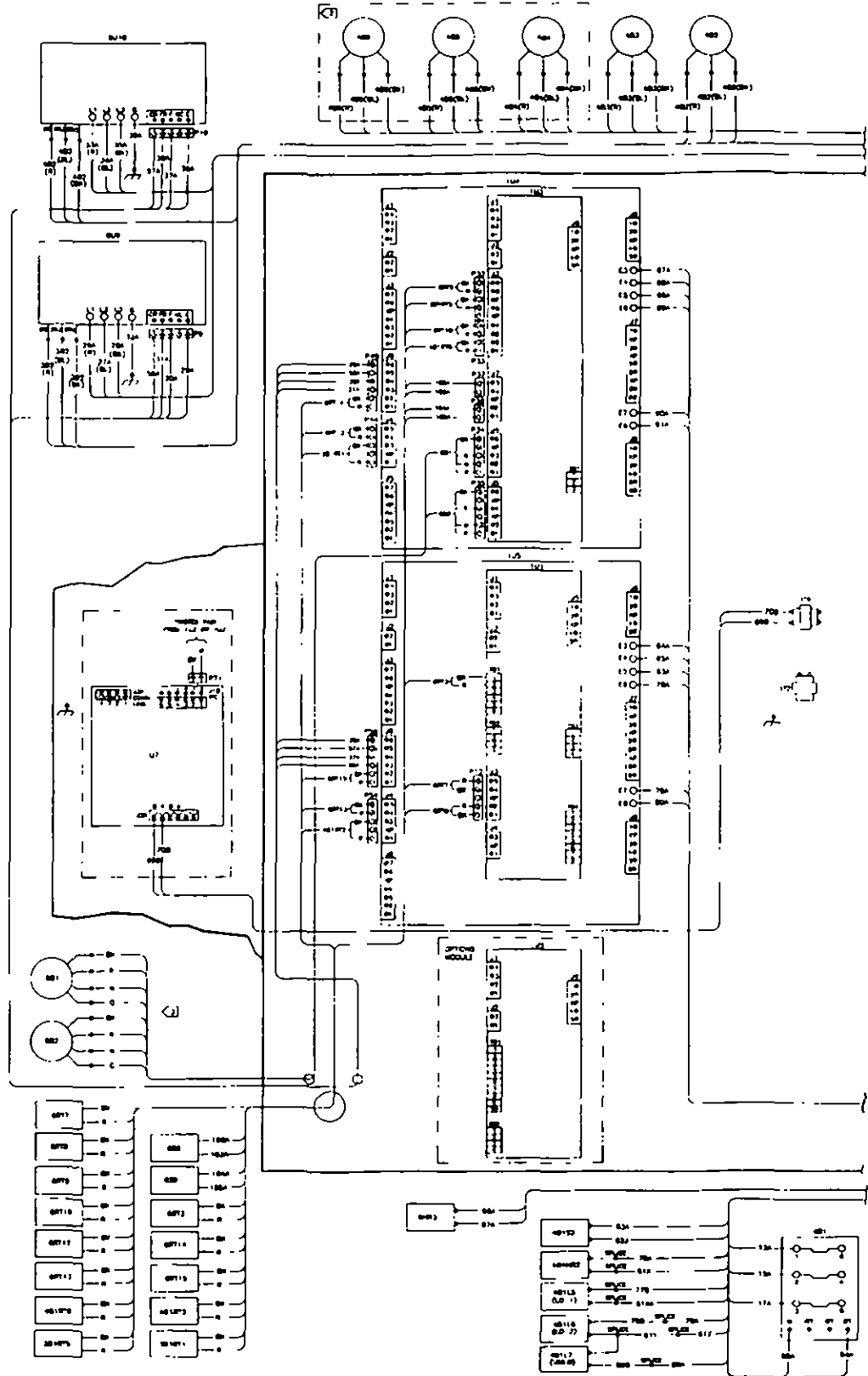




- NOTES
- 1 11 AND ASSOCIATED WIRING NOT USED ON 70 & 80 10W UNITS
  - 2 115 AND ASSOCIATED WIRING NOT USED ON 70 & 80 10W UNITS
  - 3 FUSES 1110-1113 ARE USED ON ALL UNITS (EXCEPT 700 & 230 VOLT TRANSFORMERS 1110 AND 1111 USED ON 175/80V/3 385V/60/2 AND 340/50/3 UNITS)
  - 4 TRANSFORMERS 110 AND 111 SHOWN WIRED FOR 175V. SEE WIRE #1 AND #2 FOR OTHER VOLTAGES.
  - 5 TRANSFORMER 111 SHOWN WIRED UP 200V/80HZ. SEE WIRE #1 FOR OTHER VOLTAGES.
  - 6 175V UNITS REQUIRE TWO PASSES THROUGH CURRENT TRANSFORMERS.

Figure 48  
Panel to Unit Wiring, X-Line

(Continued on  
next page)



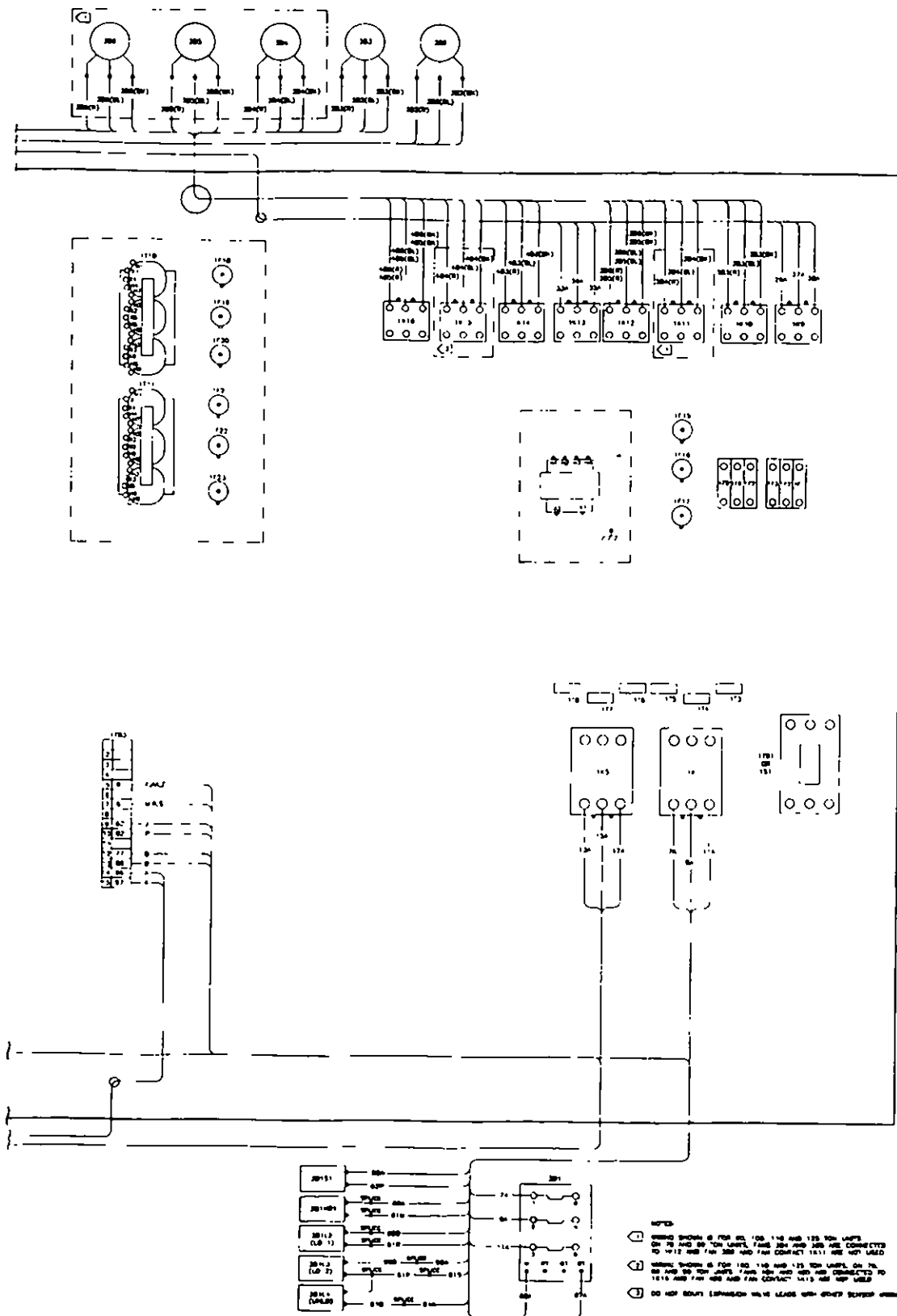
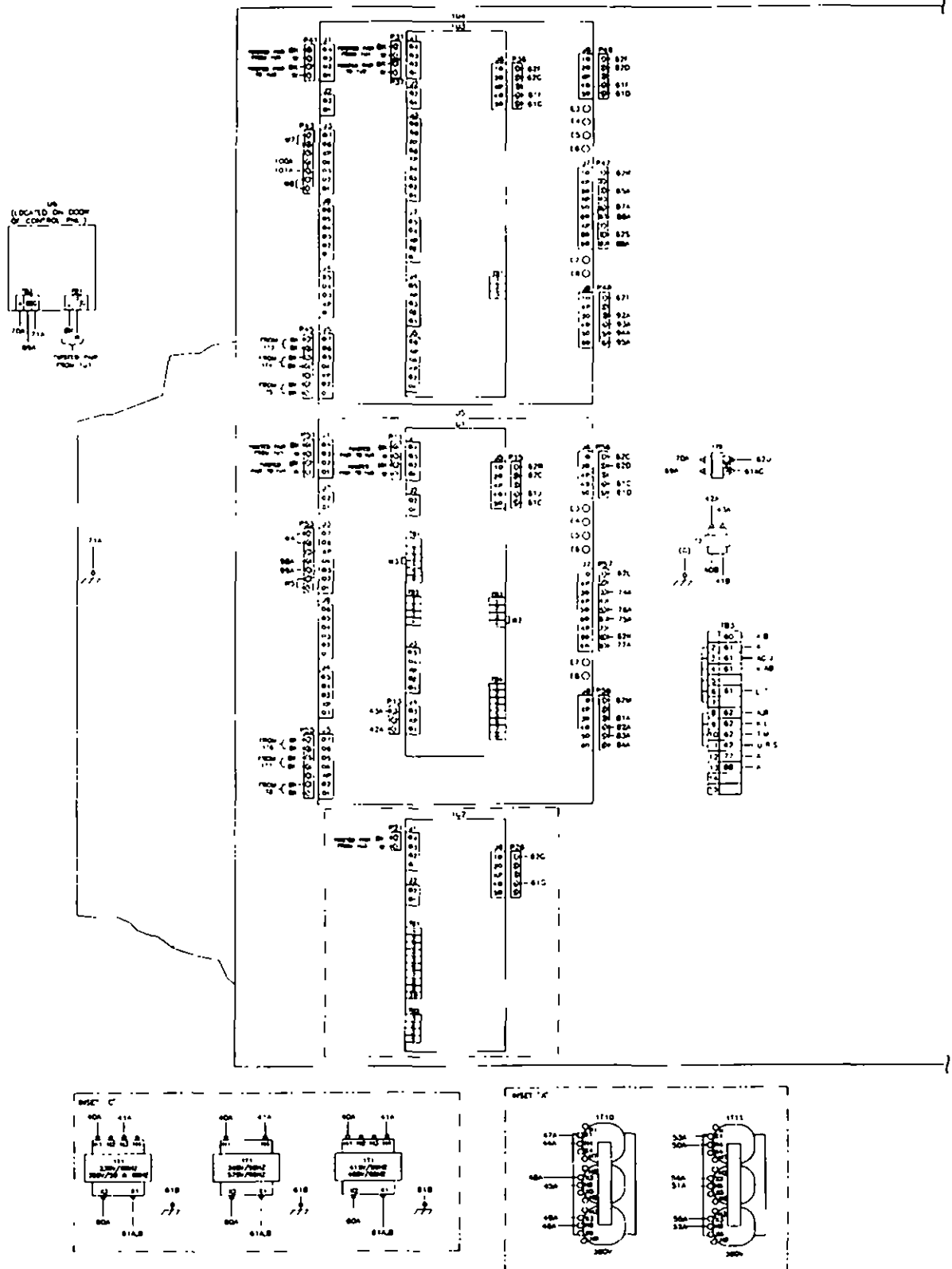
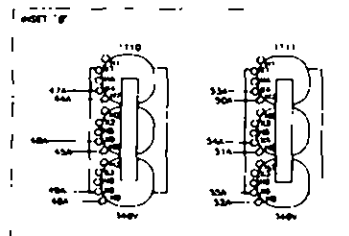
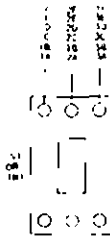
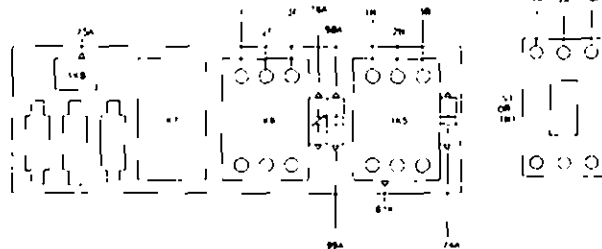
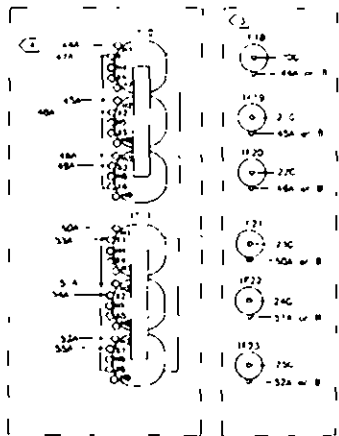
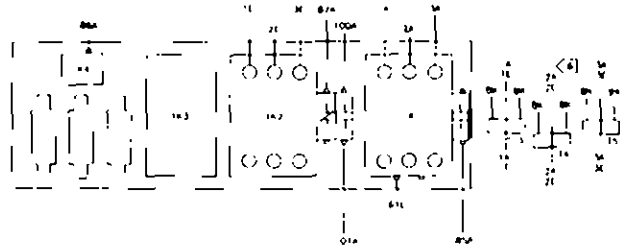
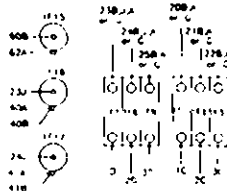
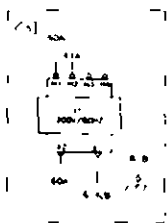
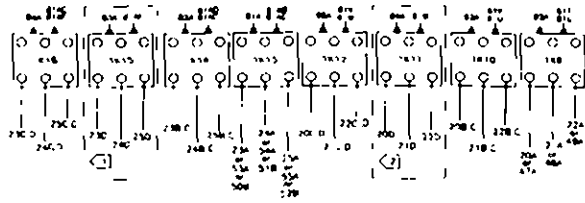


Figure 49  
Connection Wiring, Wye-Delta

(Continued on  
next page)

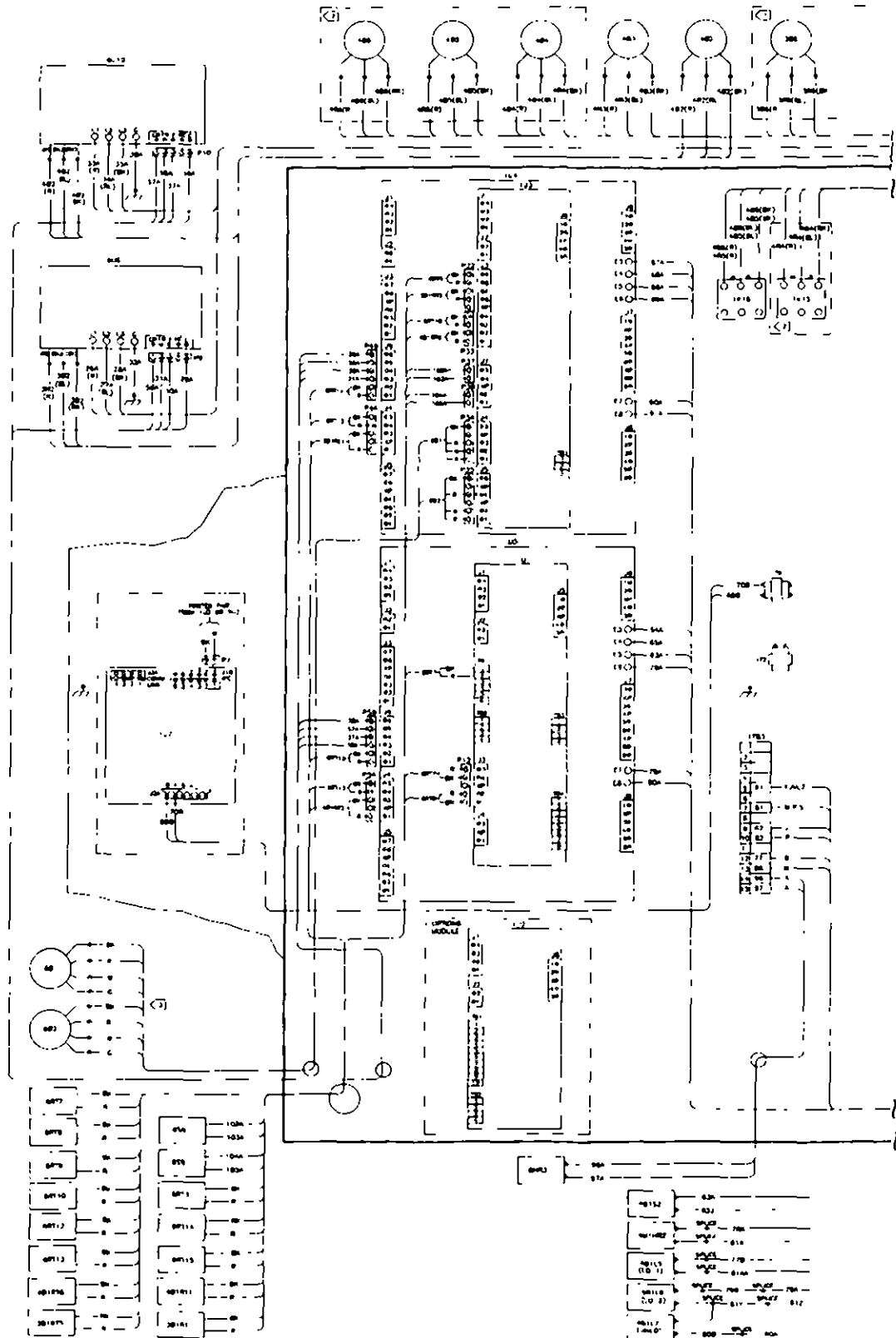




- NOTES
- 1) 1111 AND ASSOCIATED WIRES NOT USED ON 70 & 80 TON UNITS
  - 2) 1115 AND ASSOCIATED WIRES NOT USED ON 70, 80 AND 90 TON UNITS
  - 3) PLATES 1118, 23 ARE USED ON ALL UNITS EXCEPT 700 & 230 VOLTS TRANSFORMERS 1110 AND 1111 USED ON 375/80/2, 380/80/3 AND 348/50/3 UNITS.
  - 4) TRANSFORMERS 1110 AND 1111 SHOWN WIRED FOR 375V SEE INSET "A" AND "B" FOR OTHER VOLTAGES
  - 5) THROU DRIVER 1111 OPTION WIRED FOR 200/80V SEE INSET "C" FOR OTHER VOLTAGES.
  - 6) 375V UNITS REQUIRE TWO PASSES THROUGH CURRENT TRANSFORMERS.

Figure 50  
Panel to Unit Wiring, Wye-Delta

(Continued on  
next page)



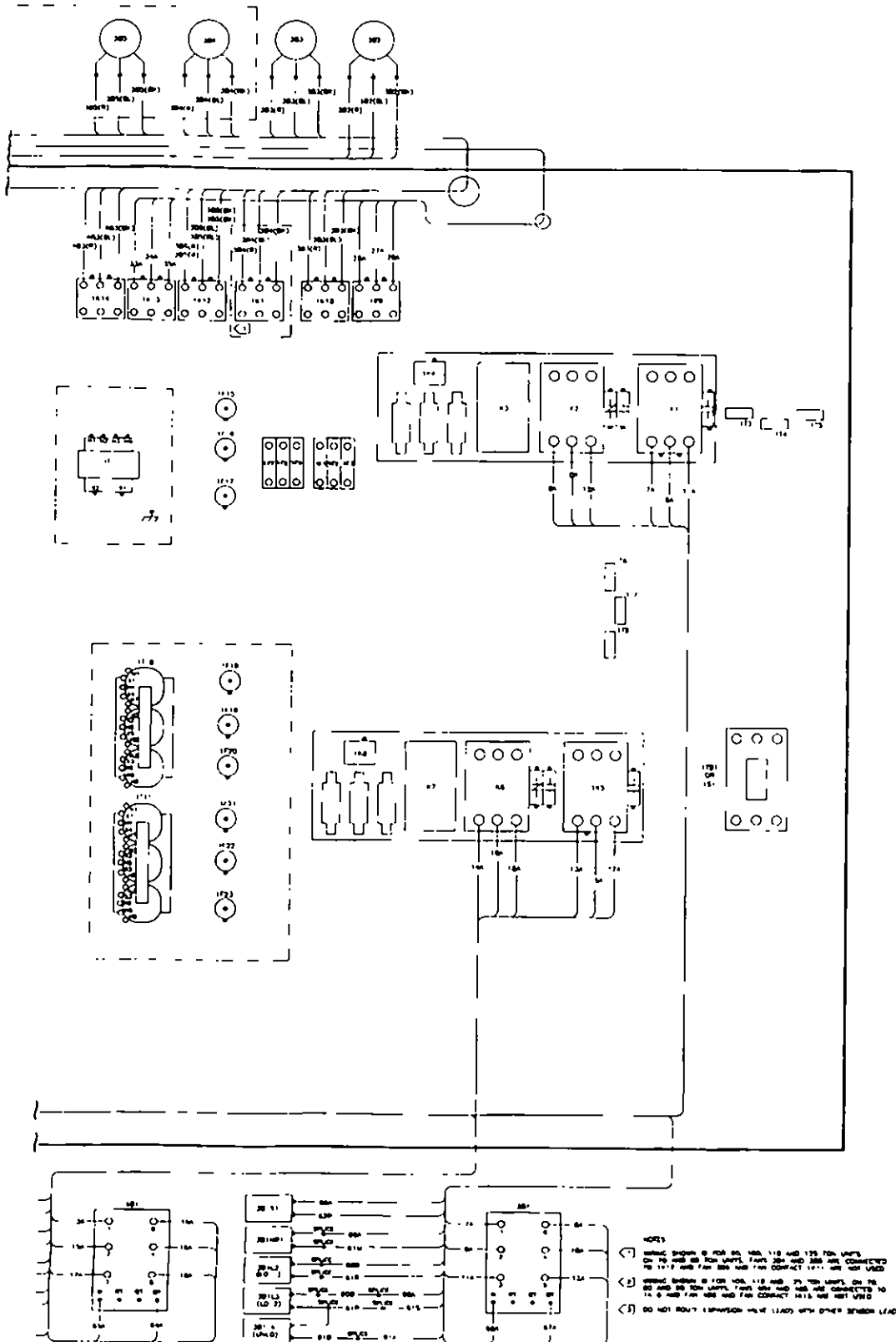
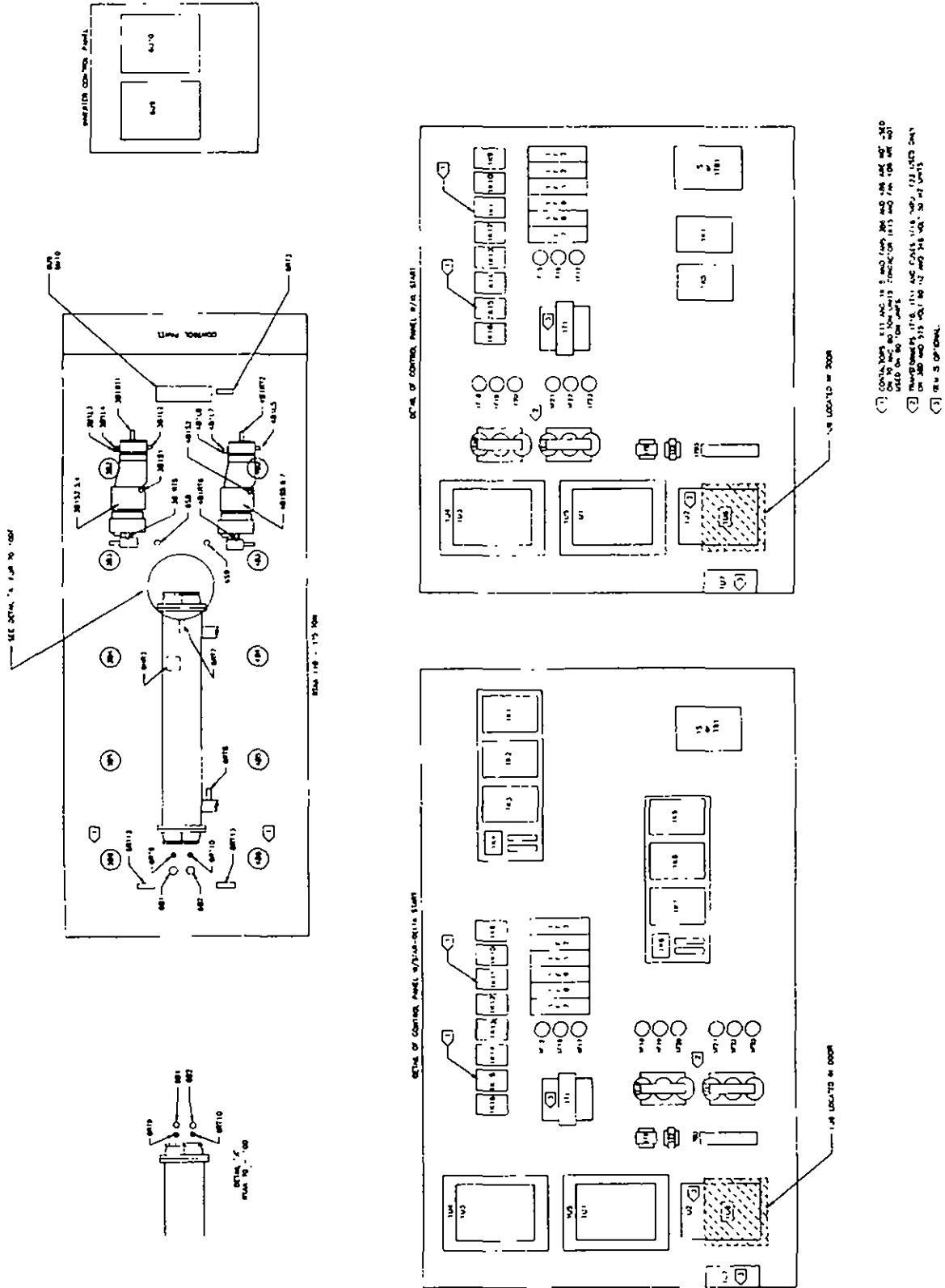




Figure 51  
Component Locations

2307-3326-D





## ***Parts Department***

Call toll-free 7am–5pm CST [800] 783-7835 or call [414] 354-0970 or fax [414] 354-7636  
The ACS Customer Service Group is ready to provide the OEM parts to keep your Sterling, Inc. systems up and running. Sterlco replacement parts ensure operation at design specifications. Please have the model and serial number of your equipment when you call.

## ***Service Department***

Call toll-free 8am–5pm CST [800] 657-4679 or call [414] 354-0970  
Emergencies after 5pm CST, call [847] 439-5655

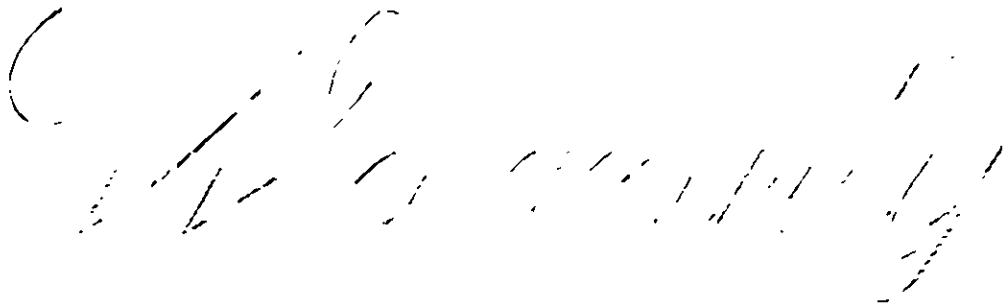
Sterling/Sterlco products are supported by the ACS Customer Service Group's qualified service department. Service contracts are available for most Sterling/Sterlco products.

## ***Sales Department***

Call [414] 354-0970 Monday–Friday, 7am–6pm CST or fax (414) 354-6421  
Sterling/Sterlco products are sold by a worldwide network of independent sales representatives. Contact our Sales Department for the name of the sales representative nearest you.

**Sterling, Inc.**

Sterling/Sterlco  
5200 West Clinton Avenue  
Milwaukee, WI 53224-9518  
[414] 354-0970 • Fax [414] 354-6421



**Sterling, Inc.** warrants all equipment manufactured by it to be free from defects in workmanship and material when used under recommended conditions. The Company's obligation is limited to repair or replace (FOB the factory) any parts for a period of 12 months from initial start-up or 18 months from the date of start-up, whichever is less, which in the Company's opinion, are defective.

This parts warranty does not cover any labor charges for replacement of parts, adjustment repairs, or any other work. This warranty does not apply to any equipment which, in the Company's opinion, has been subjected to misuse, negligence, or operation in excess of recommended limits, including freezing or which has been repaired or altered without the Company's express authorization. If the serial number has been defaced or removed from the component, the warranty on that component is void. Defective parts become the property of the warrantor and are to be returned.

The Company is not liable for any incidental, consequential, or special damages or expenses. The Company's obligation for parts not furnished as components of its manufactured equipment is limited to the warranty of the manufacturers of said parts.

Any sales, use, excise, or other tax incident to the replacement of parts under this warranty is the responsibility of the purchaser.

The company neither assumes nor authorizes any other persons to assume for it any liability in connection with the sale of its equipment not expressed in this warranty.

Many types of Sterling, Inc. equipment carry an additional one-year service policy. Consult your Sterling/Sterlco sales representative for specific details.

## **Sterling, Inc.**

PO Box 245018 • 5200 West Clinton Avenue • Milwaukee, WI 53224-9518  
Phone (414) 354-0970 • Fax (414) 354-6421  
<http://www.sterlco.com>

# Sterling, Inc.

*Auxiliary Equipment for the Process Industries*

PO Box 245018

5200 West Clinton Avenue • Milwaukee, WI 53224-9518

(414) 354-0970 • Fax (414) 354-6421



**Scrap  
Recovery Systems**



**Process Heating/  
Cooling**



**AUTOMATION  
Automated  
Parts Removal**

## Free Manuals Download Website

<http://myh66.com>

<http://usermanuals.us>

<http://www.somanuals.com>

<http://www.4manuals.cc>

<http://www.manual-lib.com>

<http://www.404manual.com>

<http://www.luxmanual.com>

<http://aubethermostatmanual.com>

Golf course search by state

<http://golfingnear.com>

Email search by domain

<http://emailbydomain.com>

Auto manuals search

<http://auto.somanuals.com>

TV manuals search

<http://tv.somanuals.com>