

STIGA TURBO

55 S ROLLER

48 S ROLLER

8211-0324-02



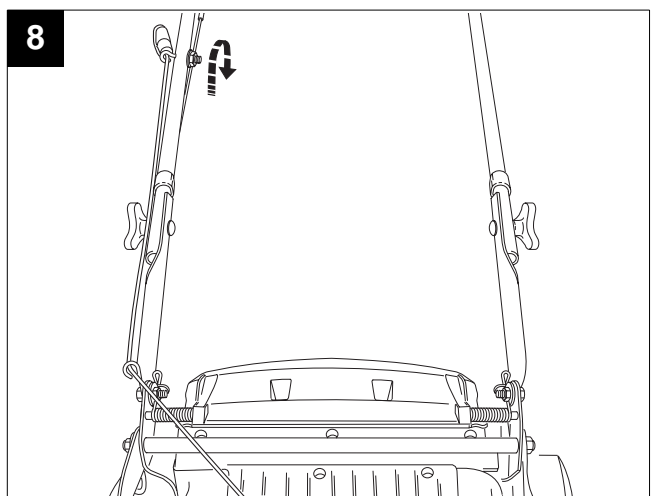
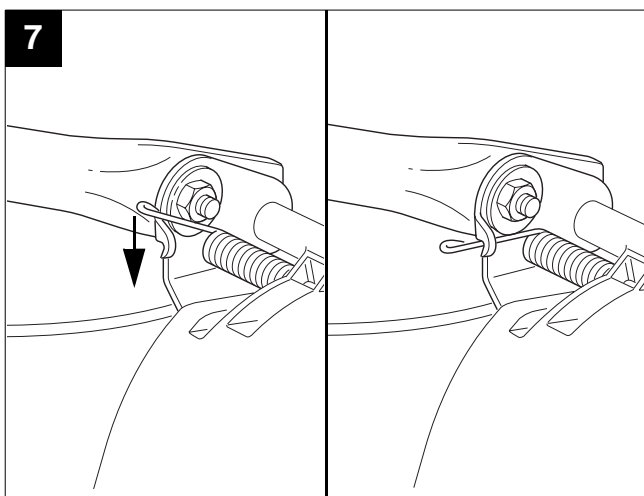
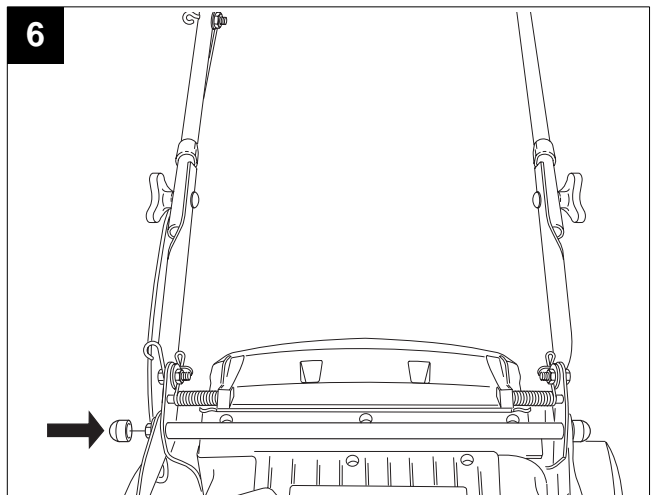
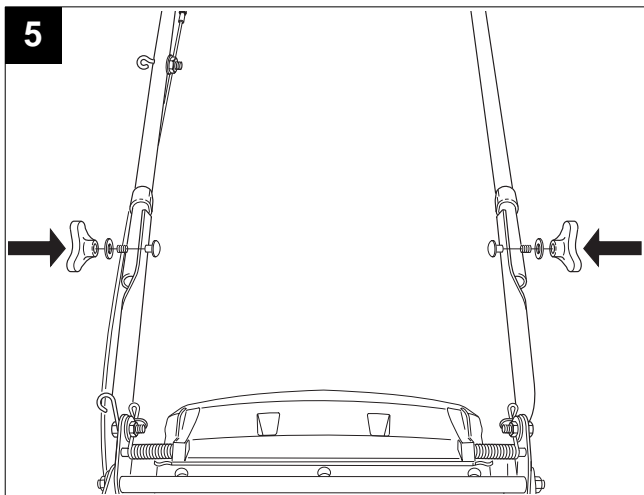
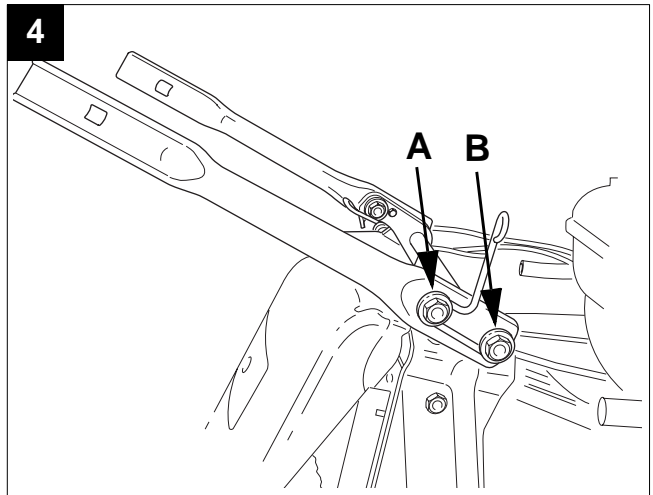
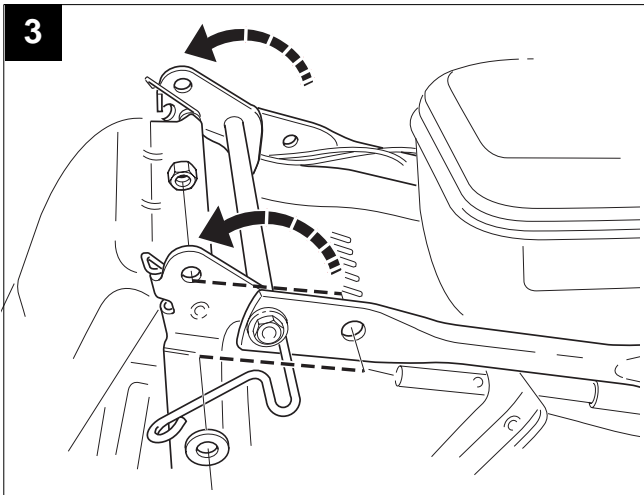
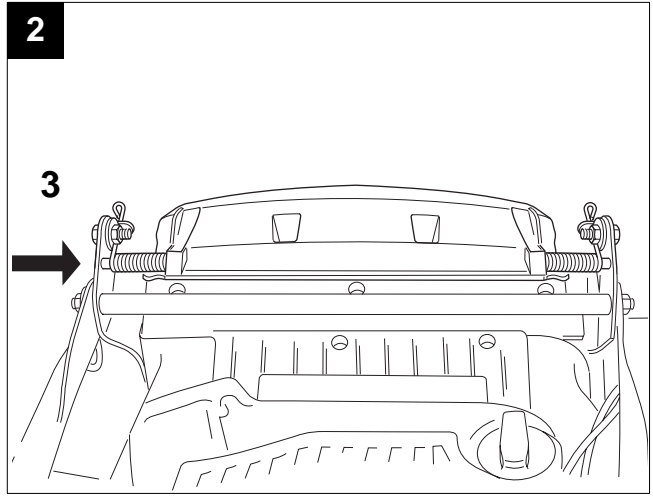
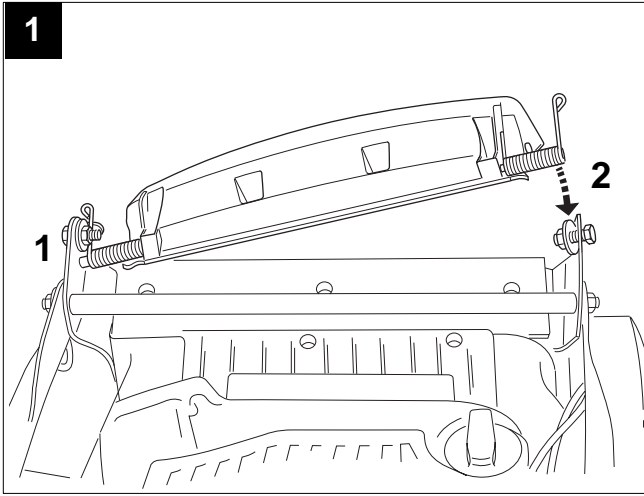

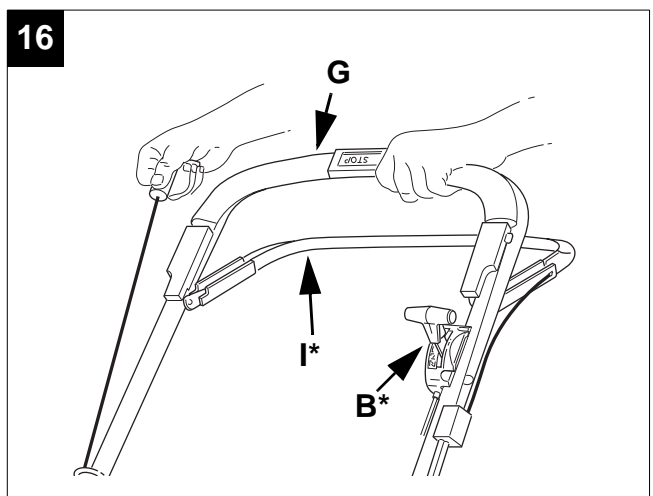
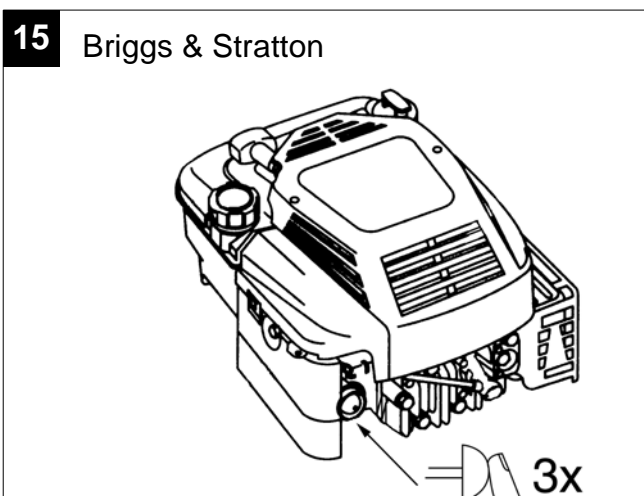
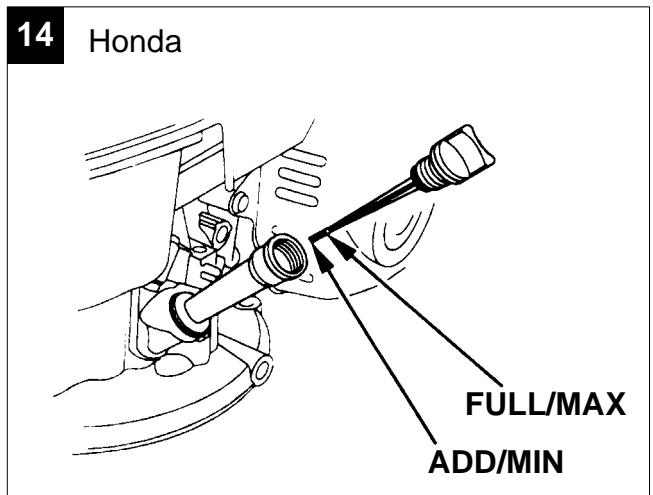
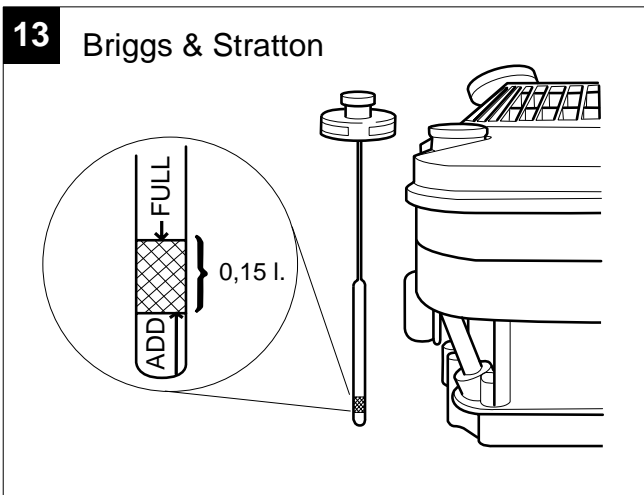
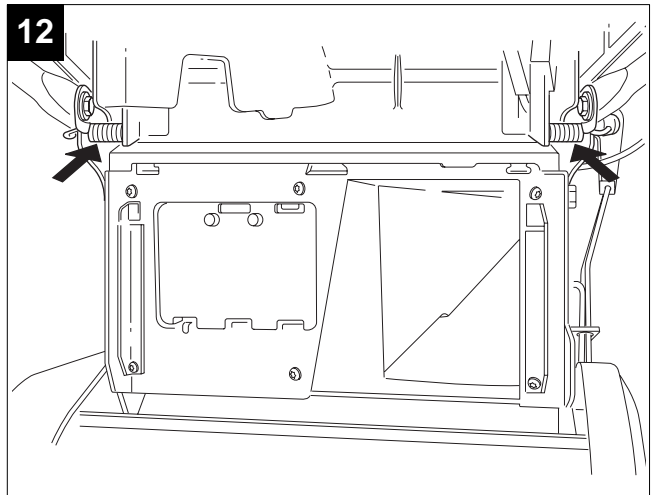
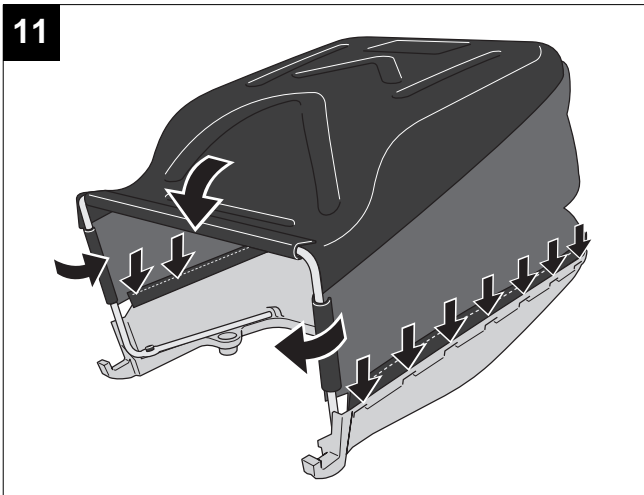
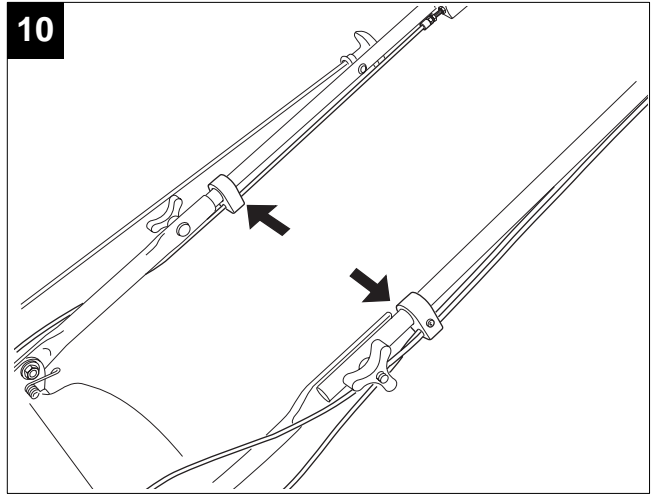
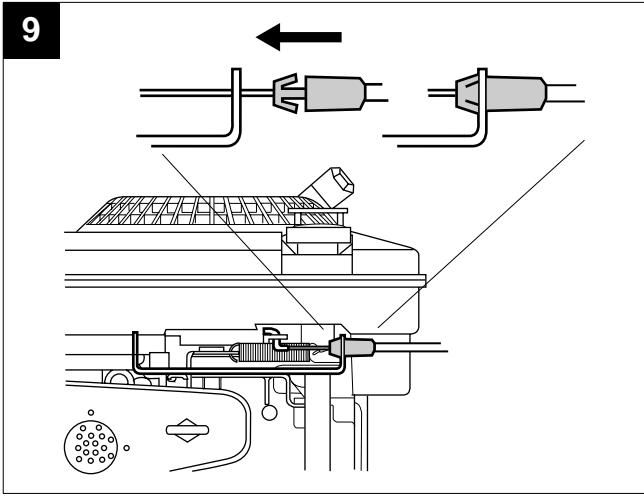

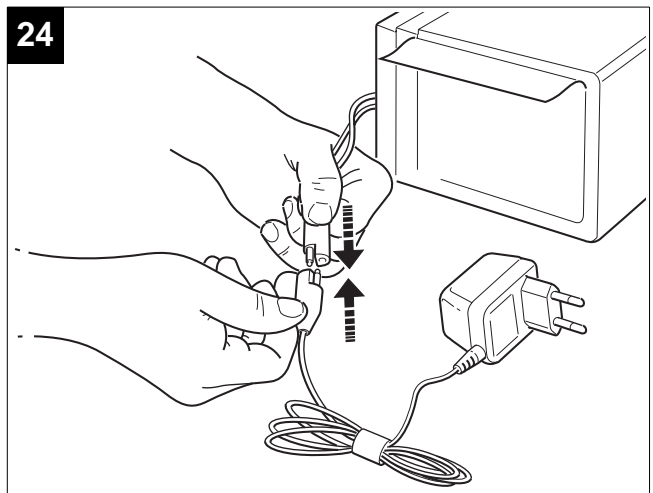
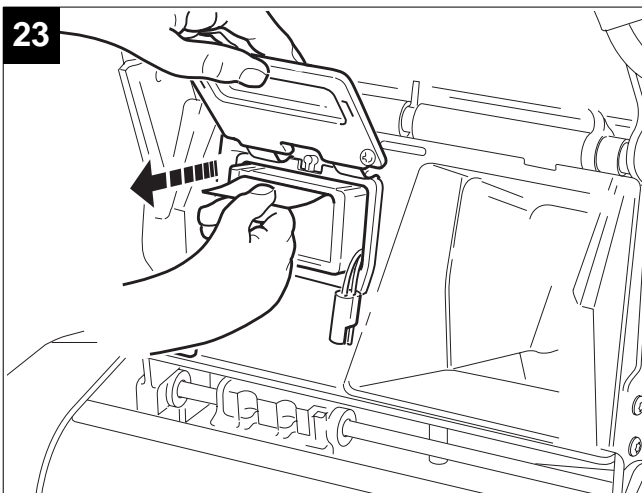
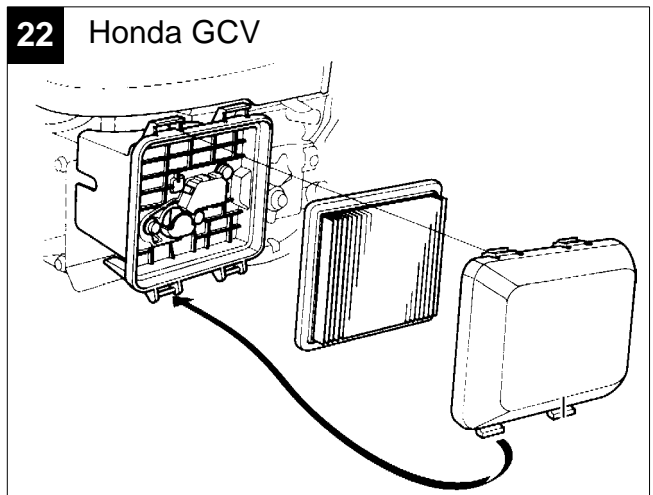
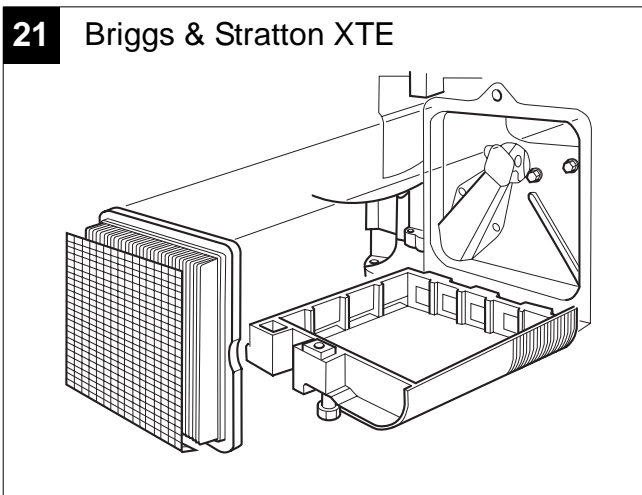
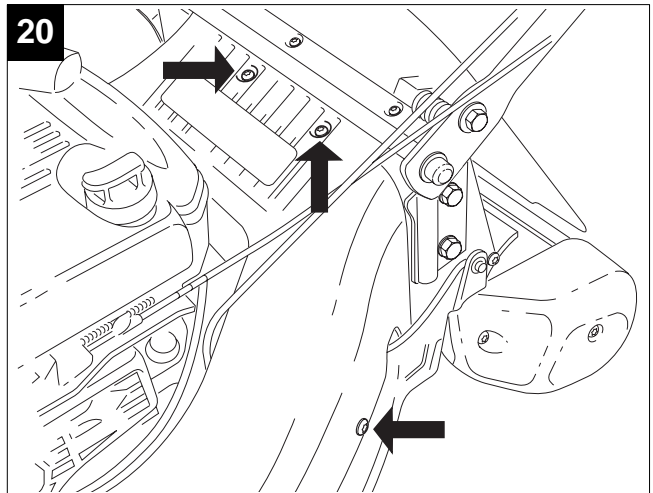
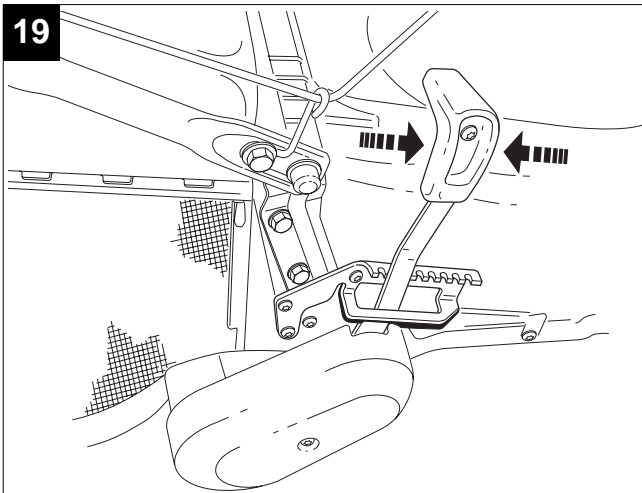
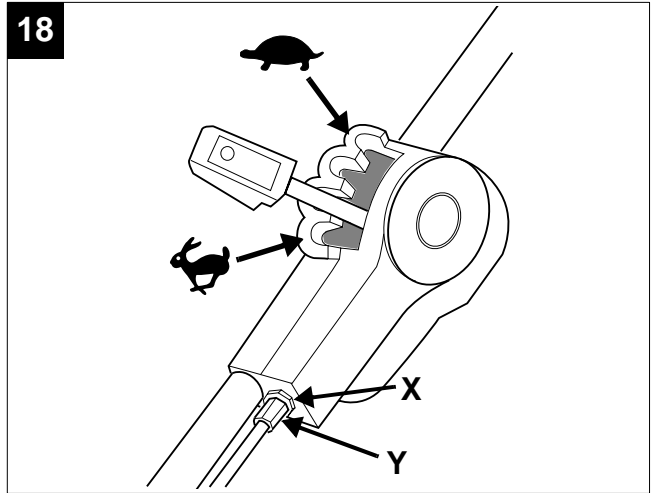
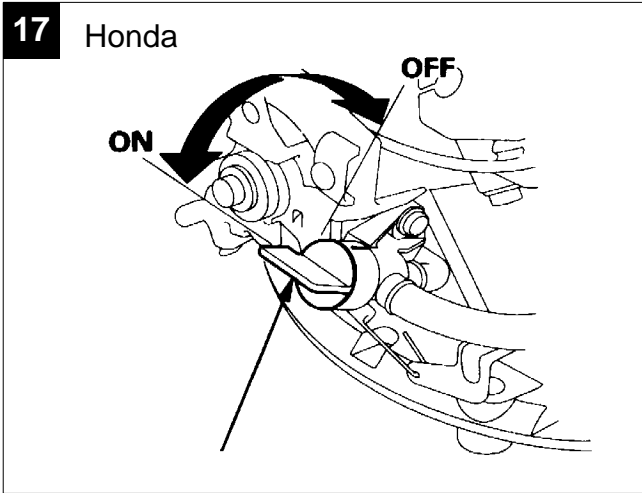

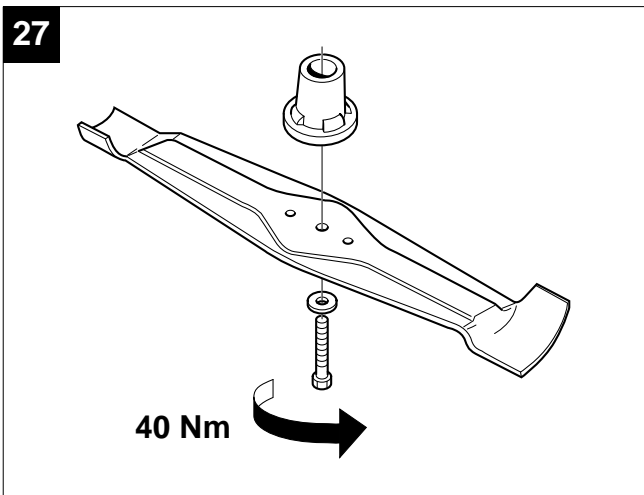
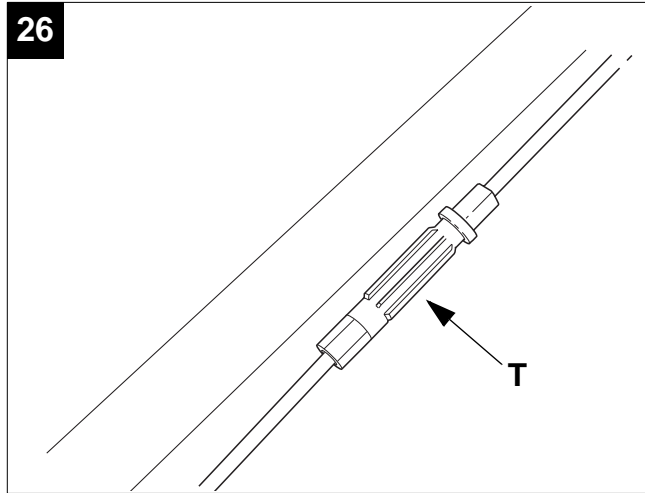
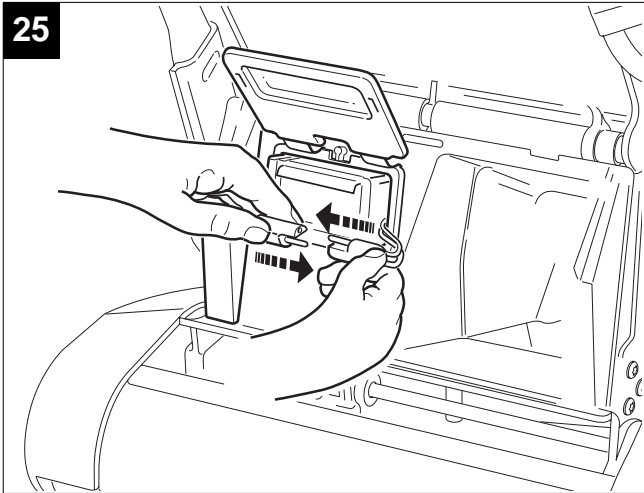







SYMBOLS

The following symbols appear on the machine. They are there to remind you of the care and attention required in use.

This is what the symbols mean:

-  Warning! Read the Instruction Book and Safety Manual before using the machine.
- 
-  Warning! Keep onlookers away. Beware of objects being flung out.
-  Warning! Keep hands and feet clear of the cutting deck when the machine is running.
-  Warning! Before starting any repair work, remove the spark plug cable from the spark plug.
- 
- 

IMPORTANT

Equipment which is marked with an asterisk (*) comes as standard in certain models or countries.

Certain models do not have throttle control. The engine's speed is set for optimal function and minimal exhaust emissions.

INTRODUCTION

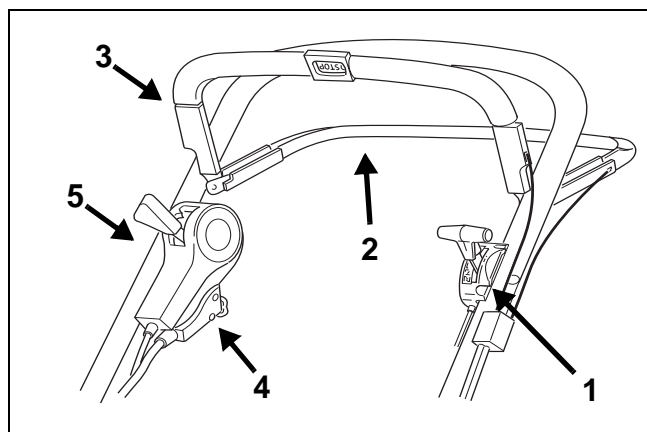

1. Throttle control (*)
2. Clutch loop
3. Start/Stop loop
4. Electric start (*)
5. Variator control

ASSEMBLY

LOOSE PARTS IN THE BOX

- 1 ignition key (*)
- 1 battery charger (*)
- 1 socket wrench
- 2 nut caps
- + Instruction books

FLAP

Install the flap according to fig. 1-2.

1. Insert the shaft into the hole on the right-hand side.
2. Fold down the flap so that the left-hand end of the shaft is directly opposite the hole.
3. Insert the left-hand end of the shaft into the hole by pressing shaft's the right-hand end. Make sure that the shaft is centred.

HANDLE

1. Remove rear screw, nut and washer and fold up the lower part of the handle (fig. 3).
2. Screw the lower part of the handle without tightening (both sides). Ensure that the lug for the starter cord is correctly positioned (fig. 4).
3. Install the upper part of the handle using screws, washers and locking wheels (fig. 5).
4. Adjust the handle so that the handlebar is horizontal.
5. Set the required height for the handle and tighten the screws **A** and **B** properly (fig. 4).
6. Thread the nut caps onto the front screw heads **B** (fig. 6).
7. Fold down the spring struts so that the flap is secured (fig. 7).
8. Carefully pull the starter handle and thread the starter cord through the lower and upper lugs. Tighten the upper lug (fig. 8).

ENGINE BRAKE CABLE

Secure the engine brake cable to the engine brake (fig. 9). Note that the cable should be installed in the direction of the handle.

CABLE HOLDERS

Secure the cables in the cable holders (fig. 10):

VARIATOR CONTROL

When the mower is delivered, the variator cable is set so that the transmission cannot be damaged. The cable may need tightening, see under heading "ADJUSTING VARIATOR CABLE" in the section "MAINTENANCE".

GRASS COLLECTOR

Fit the fabric bag over the steel frame and then snap the bag onto the plastic lid (fig. 11).

Open the flap on the machine and attach the grass collector to the brackets (fig. 12).

NOTE! The lawnmower can be operated without the grass collector. The grass is then left in a line behind the machine.

BATTERY (*)



The electrolyte in the battery is toxic and corrosive. It can cause serious corrosion damage etc. Avoid all contact with skin, eyes and clothing.

Before starting for the first time, the battery should be charged for 24 hours, see further information under the heading MAINTENANCE, BATTERY.

Insert ignition key (*) into the ignition lock.

USING THE MOWER

When mowing, the grass is collected in the collector. Empty the grass onto the compost heap or spread it over borders as fertiliser. The machine is also ideal for collecting up leaves in the autumn.

BEFORE STARTING

FILL THE CRANKCASE WITH OIL



The lawnmower is delivered without any oil in the engine crankcase. The crankcase must be filled with oil before the engine is started for the first time.

Remove the oil dipstick (fig. 13, 14). Fill the engine's crankcase with 0.55 litres of good quality oil (service class SE, SF or SG). Use SAE 30 or SAE 10W-30 oil.

Slowly fill to 'FULL/MAX'. Do not overfill.

CHECK THE OIL LEVEL

Check before using the machine that the oil level is between 'FULL/MAX' and 'ADD/MIN' on the dipstick.

Remove and wipe off the dipstick (fig. 13, 14). Slide it down completely and tighten it. Unscrew and pull it up again. Read off the oil level. If the oil level is low, fill with oil up to the 'FULL/MAX' mark.

FILL UP THE PETROL TANK



Never remove the filler cap or fill with petrol while the engine is running or still warm.

Never completely fill the petrol tank. Allow a little room for the petrol to expand if necessary.

Preferably use environmentally friendly petrol, i.e. alkylate petrol. This type of petrol has a composition that is less harmful to people and nature. It has e.g. no lead additives, no oxygenators (alcohols and ethers), no alkenes and no benzene.



NOTE! If you change to environmentally friendly petrol in an engine previously run on ordinary lead-free petrol (95), the petrol manufacturer's recommendations must be followed carefully.

Ordinary lead-free 95 octane petrol can also be used. You must never use 2-stroke petrol mixed with oil. NOTE! Bear in mind that ordinary lead-free petrol is a perishable; do not purchase more petrol than can be used within thirty days.

STARTING THE MOTOR (Briggs & Stratton)

1. Place the lawnmower on flat, firm ground. Do not start in long grass.
2. Make sure the spark plug cable is connected to the spark plug.
3. When starting a cold engine: Press down the primer fully 6 times (fig. 15).

When starting a warm engine, the primer does not need to be used. If the engine stops due to a lack of fuel, refill and press down the primer 3 times.

5. Press the Start/Stop loop **G** towards the handle.
NOTE! The Start/Stop loop **G** must be kept pressed in to prevent the engine stopping (fig. 16).

6a Manual start: Grasp the starter handle and start the engine by pulling briskly on the starter cord.

6b Electric start (*): Start the engine by turning the ignition key clockwise. Release the key as soon as the engine starts. Always make short attempts at starting in order to prevent discharging the battery.

For ease of starting, press down the handle so that the front wheels lift slightly from the ground. Do not start in thick grass.

7. For the best mowing results, the engine should always be driven at full throttle.



Keep hands and feet away from the rotating blade. Never put your hand or foot under the blade casing or in the grass ejector while the engine is running.

STARTING THE ENGINE (Honda)

1. Place the lawnmower on flat, firm ground. Do not start in long grass.
2. Make sure the spark plug cable is connected to the spark plug.
3. Open the fuel tap (fig. 17).
4. Set the throttle control **B** in the choke position . NOTE! It is not necessary to use the choke position when the engine is warm (fig. 16).
5. Press the Start/Stop loop **G** towards the handle. NOTE! The Start/Stop loop **G** must be kept pressed in to prevent the engine stopping (fig. 16).
6. Grasp the starter handle and start the engine by pulling briskly on the starter cord.
7. When the engine starts, move the throttle control backwards until max. revs are obtained. NOTE! The engine should always be run at maximum revs to avoid abnormal machine vibrations.



Keep hands and feet away from the rotating blade. Never put your hand or foot under the blade casing or in the grass ejector while the engine is running.

STOPPING THE ENGINE



The engine may be very warm immediately after it is shut off. Do not touch the silencer, cylinder or cooling fins. This can cause burn injuries.

1. Release the Start/Stop loop **G** (fig. 16) to stop the engine. This loop must not be disengaged (e.g. by setting it in the depressed position against the handle), as it will not be possible to stop the engine.

Honda: Close the fuel tap.

2. If the lawnmower is left unattended, remove the spark plug cable from the spark plug. Also remove the ignition key (*).



If the start/stop loop ceases to work, stop the engine by removing the spark plug cable from the spark plug. Immediately take the lawnmower to an authorised workshop for repair.

DRIVE

Engage the drive by pressing the clutch loop **I** towards the handle. Disengage the drive by releasing the clutch loop **I** (fig. 16).



SPEED



Do not touch the variator control when the engine is not running. This can damage the operation of the variator.

Set to a suitable speed by moving the variator control to one of the 4 positions (fig. 18).

The various positions have the following speeds:

- Position : approx. 2.8 km/h
- Position 2: approx. 3.1 km/h
- Position 3: approx. 3.6 km/h
- Position : approx. 4.5 km/h

CUTTING HEIGHT



Shut off the engine before adjusting the cutting height.

Do not set the cutting height so low that the blade comes into contact with uneven ground.

The mower has single-lever control for adjusting the cutting height. Pull the lever out, and set the cutting height to one of the positions best suited to your lawn (fig. 19).

MAINTENANCE



No servicing may be carried out on the engine or lawnmower without first removing the spark plug cable from the spark plug.

Stop the engine and remove the spark plug cable if the mower is to be lifted, e.g. during transportation.

If the lawnmower needs to be tilted, it must be tilted so that the engine's spark plug faces upwards. Tilt the lawnmower when the fuel tank is empty.

CLEANING

After use, the mower should be cleaned. This is particularly important on the underside of the mower casing. Rinse clean with the garden hose. The mower will then last longer and work better. High-pressure washers should not be used.

If grass has dried on to the mower casing, it can be scraped clean. If necessary, touch up the underside with paint to prevent rust damage.



Clean the silencer and the surrounding area regularly to remove grass, dirt and flammable waste products.

Remove the transmission casing by removing the screws **S** (fig. 20) and clean around the transmission and drive belts with a brush or compressed air once or twice a year.

The drive chain should be lubricated once per season. Remove the right-hand cover from the roller and apply a little chain spray onto the chain.

COOLING SYSTEM

Before each use, the engine's cooling system must be cleaned. Clean the cylinder's cooling flanges and air intake of grass remains, dirt, etc.

OIL CHANGE



Change the oil when the engine is warm and the fuel tank is empty. In order to prevent burns, take care while draining as the oil is hot.

Change the oil the first time after 5 hours of operation, and subsequently every 50 hours of operation or once a season. Remove the dipstick, tilt the mower and let the oil run out into a container. Be careful not to let any oil run on to the grass.

Fill with new oil: Use SAE 30 or SAE 10W-30 oil. The crankcase holds approx. 0.55 litres. Fill until the oil reaches the "FULL/MAX" mark on the dipstick.

AIR FILTER

A dirty and blocked air filter reduces the engine output and increases engine wear.

Briggs & Stratton (fig. 21):

Undo the screw and fold down the cover of the air cleaner. Carefully remove the filter cartridge. Knock it against a flat surface. Replace the filter cartridge with a new one if it is still dirty.

Clean the filter every three months or after every 25 hours of use, whichever occurs first. More frequently if the engine is working on dusty ground.

Honda (fig. 22): Remove the cover and take out the filter. Carefully check the filter for holes or other damage. A broken or damaged filter must be replaced.

To remove dirt, carefully knock the filter several times against a hard surface or use compressed air from the back of the filter to blow-clean. Do not try to brush the filter clean as this forces dirt down into the fibres. A very dirty filter should be replaced.

Clean the air filter after every 25 hours of operation or once a season. More frequently if the engine is working on dusty ground.

SPARK PLUG



Never remove the spark plug or spark plug cable when checking to see if there is a spark. Use an approved test instrument.

Clean the spark plug regularly (every 100 hours of run time). Use a wire brush for cleaning.

Change the spark plug if the electrodes are excessively burnt or if the plug is damaged. The engine manufacturers' recommendations are as follows:

Briggs & Stratton: Champion J19LM (RJ19LM), Spark gap 0.76 mm.

Honda: NGK BPR6ES, Spark gap 0.7-0.8 mm.

BATTERY (*)



The electrolyte in the battery is toxic and corrosive. It can cause serious corrosion damage etc. Avoid all contact with skin, eyes and clothing.

In normal use during the season, the battery is charged by the engine. If the engine cannot be started with the ignition key, it may be because the battery is 'dead'.

Dismantle the battery by opening the battery cover, disconnecting the terminal on the engine and removing the battery (fig. 23). Connect the battery charger (provided) to the battery, then connect the charger to a wall socket and charge for 24 hours (fig. 24).

After charging, the battery may be reinstalled and the terminal on the battery connected to the terminal on the engine (fig. 25).

The battery charger may not be connected directly to the engine terminal. It is not possible to start the engine with the charger as the power source and the charger could be damaged.

WINTER STORAGE

Remove the battery and store it fully charged (see above) in a dry, cool place (between 0°C and +15°C). The battery should be maintenance-charged at least once during the winter storage period.

Before the start of the season, the battery should be charged once again for 24 hours.

ADJUSTING CLUTCH CABLE

If the drive does not engage when the clutch loop is pressed against the handle, or if the lawnmower feels cumbersome or slow, this may be because the clutch in the transmission is slipping. To rectify this situation, adjust the clutch cable as follows:

1. When the clutch loop is released, it should be possible to push the mower without any resistance. If this is not the case, screw in the nipple **T** until the mower can be pushed (fig. 26).

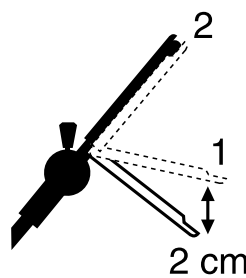

2. When the clutch loop is pressed in approx. 2 cm (position 1), there should be some resistance when pushing the lawnmower. With the clutch loop fully pressed in (position 2) it should not be possible to push the mower. Unscrew the nipple **T** until this position is

achieved.

ADJUSTING VARIATOR CABLE

If the speed difference between the settings in the variator control giving the fastest speed (position 3 and ) appears insignificant or nothing at all, the variator cable might need tightening (fig. 18).

1. Run the mower for a few minutes in position .
2. If the variator cable shows some play in nipple **Y** it needs tightening. Undo the locking nut **X** and tighten the cable by unscrewing the nipple **Y** until the cable ceases to show any play.
3. Tighten the locking nut **X**.

NOTE! Do not stretch the cable beyond the point where there is no play in the nipple **Y**. If the cable is over-tightened, the drive belt could break and/or other parts of the transmission be damaged. When setting after e.g. belt change, always start with the nipple **Y** completely screwed in.

CHANGING BLADES



Use protective gloves when changing blade to avoid cutting yourself.

Check the blade system regularly. Check particularly the curved area behind the blade edge for traces of wear. If the blade shows traces of damage it should be replaced. A worn blade creates imbalance and can damage the mower.

Always check the blade after an impact. First disconnect the spark plug cable. If the blade system has been damaged, defective parts should be replaced. Always use genuine spare parts.

To replace the blade, undo the screw (fig. 27). Fit the new blade so that the stamped logo is turned up facing the blade holder (not facing the grass).

Reinstall as illustrated. Tighten the screw properly. Tightening torque 40 Nm.

When replacing the blade, the blade screw should also be replaced.

The guarantee does not cover damage to the blade, blade holder or engine caused by running into obstacles.

When replacing the blade, blade holder and blade screw, always use genuine spare parts. Non-genuine spare parts can entail a risk of injury or damage, even if they fit the machine.

SHARPENING THE BLADES

Sharpening of the blades must be done by wet method grinding, using a whetstone or a grindstone.

For safety reasons, the blades should not be sharpened on an emery wheel. A very high temperature could cause the blades to become brittle.



Once the blade has been sharpened, it must then be balanced to avoid vibration damage.

STORAGE

WINTER STORAGE

Empty the fuel tank. Start the engine and let it run until it stops. The same petrol must not remain in the tank for more than one month.

Tip up the mower and unscrew the spark plug. Pour a tablespoon of engine oil into the spark plug hole. Pull out the starter handle slowly so that the oil is distributed in the cylinder. Screw in the spark plug.

Thoroughly clean the mower and store it indoors in a dry place.

SERVICING

Genuine spare parts are supplied by service workshops and by many dealers.



MOWING AHEAD

GGP Sweden AB • Box 1006 • SE-573 28 TRANÅS

www.stiga.com

Free Manuals Download Website

<http://myh66.com>

<http://usermanuals.us>

<http://www.somanuals.com>

<http://www.4manuals.cc>

<http://www.manual-lib.com>

<http://www.404manual.com>

<http://www.luxmanual.com>

<http://aubethermostatmanual.com>

Golf course search by state

<http://golfingnear.com>

Email search by domain

<http://emailbydomain.com>

Auto manuals search

<http://auto.somanuals.com>

TV manuals search

<http://tv.somanuals.com>