



BRUKSANVISNING SV	6
KÄYTTÖOHJEET FI ...	14
BRUGSANVISNING DA..	22
BRUKSANVISNING NO .	30
GEBRAUCHSANWEISUNG DE...	38
INSTRUCTIONS FOR USE EN...	47
MODE D'EMPLOI FR....	56
GEBRUIKSAANWIJZING NL...	65

STIGA PARK

COMPACT

COMPACT HST

COMPACT 4WD

STIGA[®]

8211-0001-70

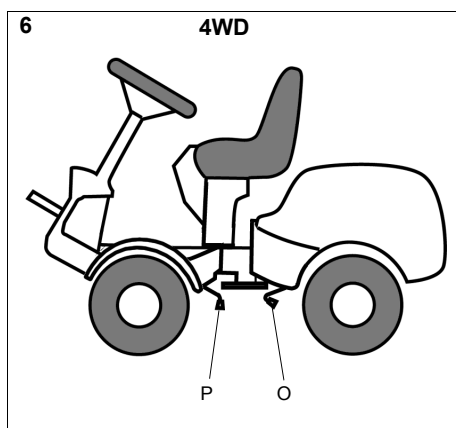
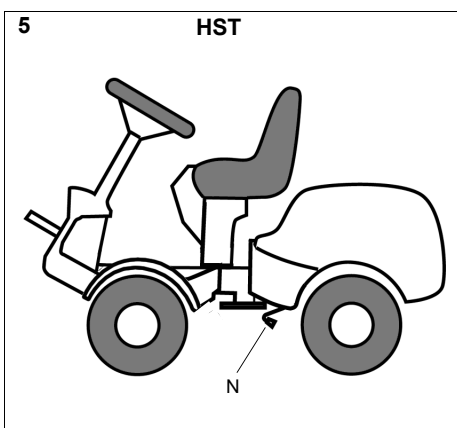
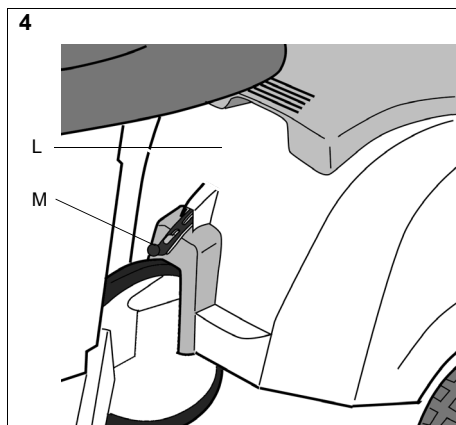
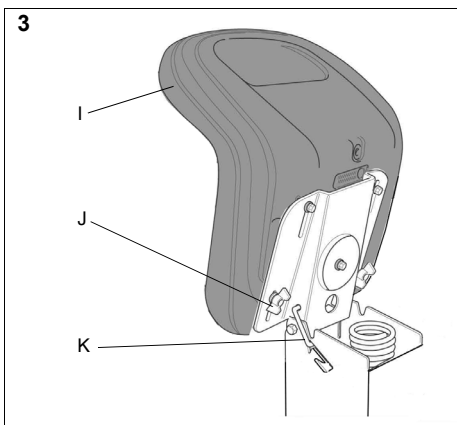
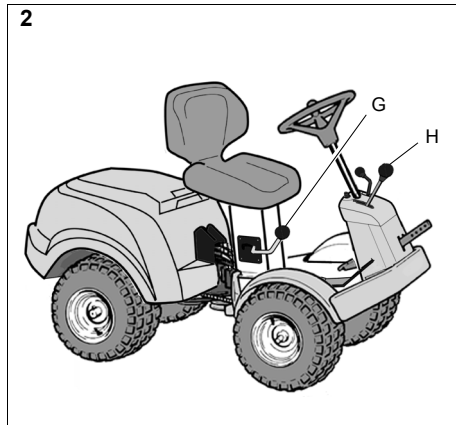
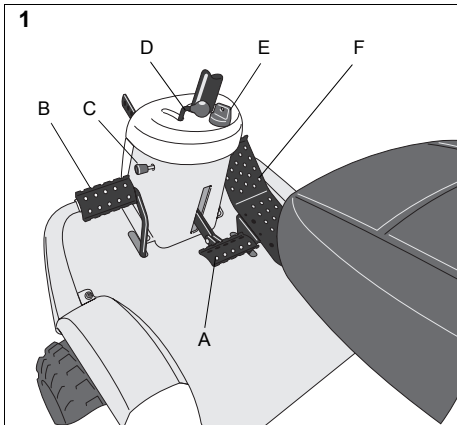

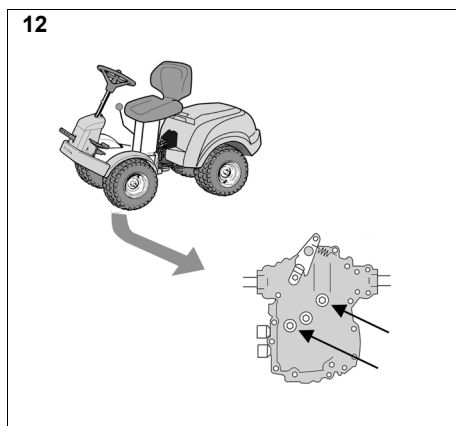
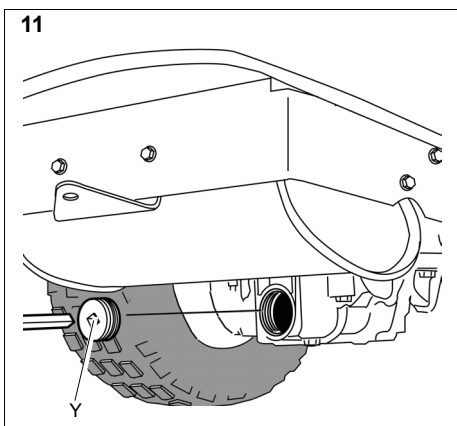
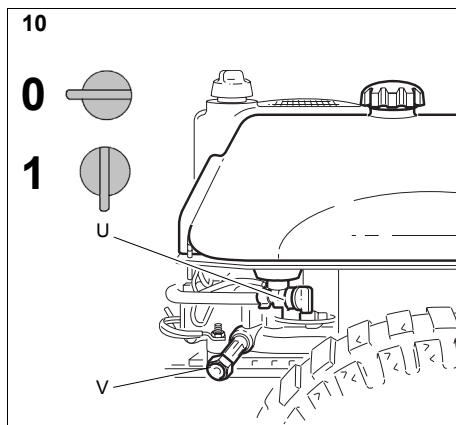
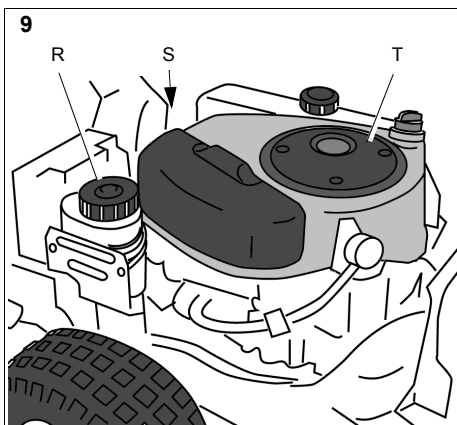
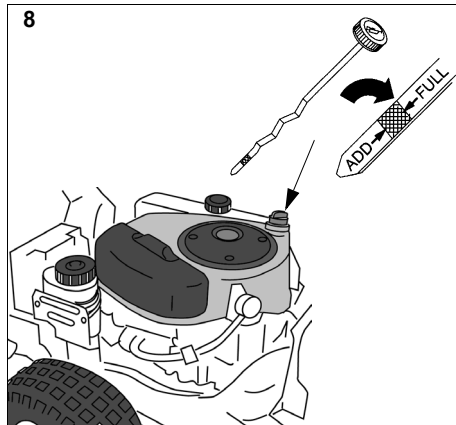
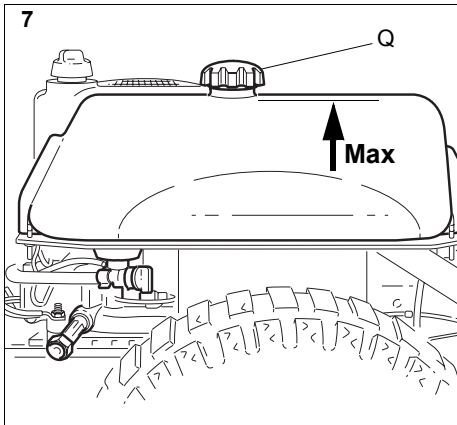

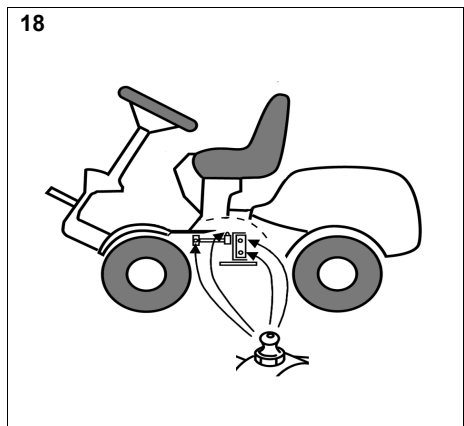
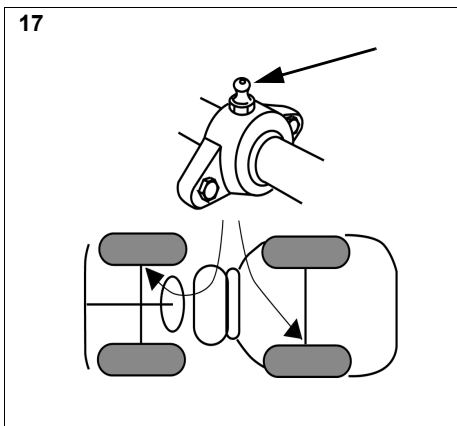
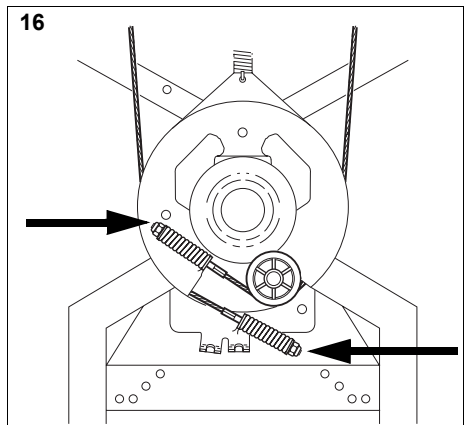
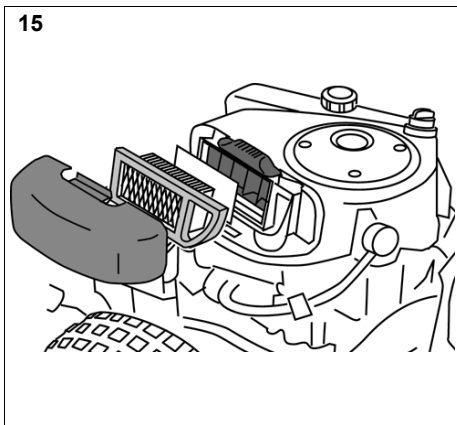
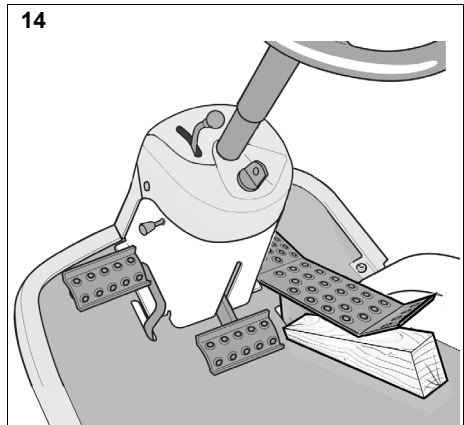
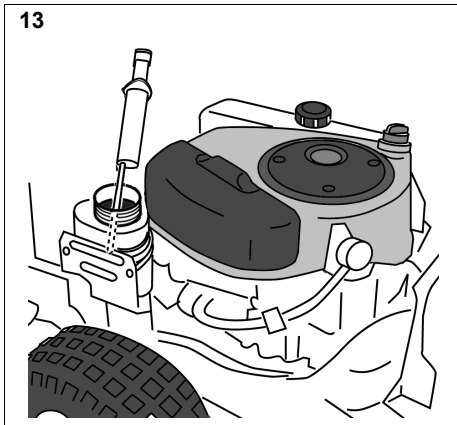

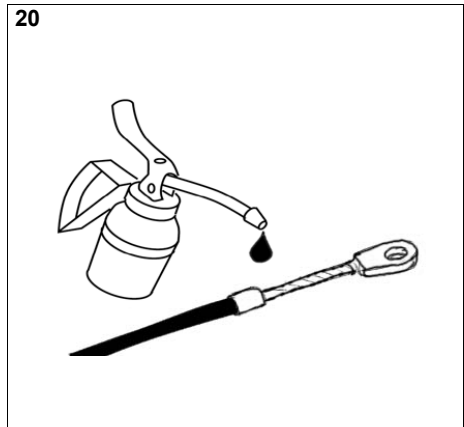
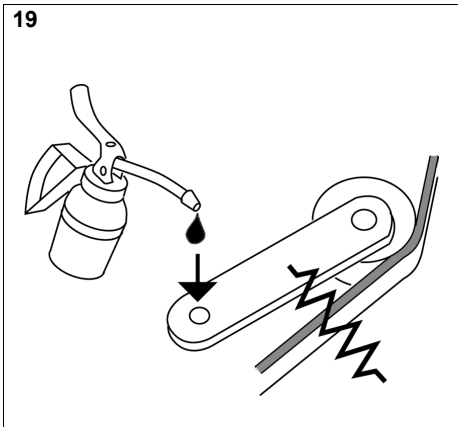

1 GENERAL



This symbol indicates **WARNING**. Serious personal injury and/or damage to property may result if the instructions are not followed carefully.



You must read these instructions for use and the accompanying pamphlet "SAFETY INSTRUCTIONS" carefully, before starting up the machine.

1.1 SYMBOLS

The following symbols appear on the machine. They are there to remind you of the care and attention required during use and maintenance.

This is what the symbols mean:



Warning!
Read the instruction manual and the safety manual before using the machine.



Warning!
Watch out for discarded objects. Keep on-lookers away.



Warning!
Always wear hearing protectors.



Warning!
This machine is not designed to be driven on public roads.



Warning!
The machine, equipped with original accessories, must not be driven in any direction on slopes with a gradient greater than 10°.



Warning!
Risk of crushing injuries. Keep hands and feet well away from the articulated steering joint.



Warning!
Risk of burn injuries. Do not touch the silencer/catalytic converter.

1.2 Designations

Three versions of Park Compact are available and are designated in the table below:

Machine	Designation
Compact with manual transmission.	Man
Compact HST with hydrostatic transmission.	HST
Compact 4WD with hydrostatic transmission and four wheel drive.	4WD

1.3 References

1.3.1 Figures

The figures in these instructions for use are numbered 1, 2, 3, etc.

Components shown in the figures are marked A, B, C, etc.

A reference to component C in figure 2 is written "2:C".

1.3.2 Headings

The headings in these instructions for use are numbered in accordance with the following example: "1.3.1 General safety check" is a subheading to "1.3 Safety checks" and is included under this heading.

When referring to headings, only the number of the heading is normally specified. E.g. "See 1.3.1".

2 DESCRIPTION

2.1 Transmission

2.1.1 Man

The machine is rear wheel drive.

The rear axle is equipped with a manual transmission with 5 forward gears and one reverse gear.

The rear axle is also equipped with a differential to facilitate turning.

Front mounted tools are driven by drive belts.

2.1.2 HST

The machine is rear wheel drive.

The rear axle is equipped with a hydrostatic transmission with infinitely variable forward and reverse gear ratios.

The rear axle is also equipped with a differential to facilitate turning.

Front mounted tools are driven by drive belts.

2.1.3 4WD

The machine has 4-wheel drive. The power from the engine to the drive wheels is transferred hydraulically. The engine drives an oil pump, which pumps oil through the rear and front axle drives.

The front axle and rear axle are connected in series, which means that the front wheels and rear wheels are forced to rotate at the same speed.

To make turning easier, both axles are equipped with differential.

Front-mounted implements are powered via drive belts.

2.2 Steering

The machine is articulated. This means that the chassis is divided into a front and a rear section, which can be turned in relation to each other.

The articulated steering means that the machine can turn around trees and other obstacles with an extremely small turning radius.

2.3 Safety system

The machine is equipped with an electrical safety system. The safety system interrupts certain activities that can entail a danger of incorrect manoeuvres. For example, the engine cannot be started if the clutch-parking brake pedal is depressed.



The operation of the safety system must always be checked every time before use.

2.4 Controls

2.4.1 Implement lifter, mechanical (1:A)

To switch between working position and transport position:

1. Depress the pedal fully.
2. Release the pedal slowly.

2.4.2 Service brake - Clutch (1:B) (Man)

A pedal that combines both service brake and clutch. There are 3 positions:

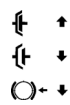

1. Pedal released – forward drive engaged. The machine will move if a gear is engaged. Service brake not activated.
2. Pedal depressed halfway – forward drive disengaged, gear shifting can be performed. Service brake not activated.
3. Pedal fully depressed – forward drive disengaged. Service brake fully activated.

NOTE! You must never regulate the operating speed by slipping the clutch. Use a suitable gear instead, so that the right speed is obtained.

2.4.3 Clutch-parking brake (1:B) (HST, 4WD)



Never press the pedal while driving. There is a risk of overheating in the power transmission.

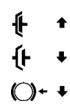

The pedal has the following three positions:

- **Released.** The clutch is not activated. The parking brake is not activated.
- **Depressed halfway.** Forward drive disengaged. The parking brake is not activated.
- **Fully depressed.** Forward drive disengaged. The parking brake is fully activated but not locked. This position is also used as emergency brake.

2.4.4 Inhibitor, parking brake (1:C)



The inhibitor locks the “clutch-brake” pedal in the depressed position. This function is used to lock the machine on slopes, during transport, etc., when the engine is not running.

Locking:

1. Depress the pedal (3:B) fully.
2. Move the inhibitor (3:C) to the right.
3. Release the pedal (3:B).
4. Release the inhibitor (3:C).

Unlocking:

Press and release the pedal (3:B).

2.4.5 Driving-service brake (1:F) (HST, 4WD)



If the machine does not brake as expected when the pedal is released, the left pedal (1:B) should be used as an emergency brake.

The pedal determines the gearing ratio between the engine and the drive wheels (= the speed). When the pedal is released, the service brake is activated.



1. Press the pedal forward – the machine moves forward.
2. No load on the pedal – the machine is stationary.
3. Press the pedal backward – the machine reverses.
4. Reduce the pressure on the pedal – the machine brakes.

2.4.6 Throttle and choke control (1:D) (Prestige)

A control for setting the engine speed and to choke the engine when starting from cold.



If the engine runs unevenly there is a risk that the control is too far forward so that the choke is activated. This damages the engine, increases fuel consumption and is harmful to the environment.



1. Choke – for starting a cold engine. The choke position is located at the front of the groove.

Do not operate in this position when the engine is warm.



2. Full throttle – when the machine is in operation, full throttle should always be used.

The full throttle position is approximately 2 cm behind the choke position.



3. Idling.

2.4.7 Ignition lock (1:E)

Do not leave the machine with the key in position 2 or 3. There is a fire risk, fuel can run into the engine through the carburettor, and there is a risk of the battery being discharged and damaged.

Ignition lock used for starting/stopping the engine. Four positions:



1. Stop position – the engine is short-circuited. The key can be removed.



2/3. Operating position.



4. Start position – the electric start motor is activated when the key is turned to the spring-loaded start position. Once the engine has started, let the key return to operating position 2/3.

2.4.8 Gear lever (2:H) (Man))

A lever for selecting one of the five forward gears in the gearbox (1-2-3-4-5), neutral (N) or reverse (R).

The clutch pedal must be kept pressed in when changing gear.

NOTE! You must make sure the machine is quite stationary before changing from reverse to forward gear or vice versa. If a gear does not engage immediately, release the clutch pedal and then press it in once again. Engage the gear once again. Never force a gear in.

2.4.9 Power take-off (2:G)

A lever for engaging and disengaging the power take-off for operating front-mounted accessories. Two positions:



1. Lever in forward position – power take-off disengaged.



2. Lever in backward position - power take-off engaged.

2.4.10 Clutch release lever (HST, 4WD)

A lever for disengaging the variable transmission. HST is equipped with a lever, connected to the rear axle. See (5:N).

4WD is equipped with two levers, connected to the rear axle (6:O) and the front axle (6:P).



The disengagement lever must never be between the outer and inner positions. This overheats and damages the transmission.

The levers enable the machine to be moved by hand without the help of the engine. Two positions:



1. Lever in the inner position – transmission engaged for normal operation.

2. Lever in the outer position – transmission disengaged. The machine can be moved by hand.

The machine may not be towed over long distances or at high speeds. The transmission could be damaged.



The machine must not be operated with the forward most lever in the outer position. Risk of damage and oil leakage in the front axle.

2.4.11 Seat (3:I)

The seat can be folded and is adjustable front-rear. The seat is locked in the folded up position using the catch (3:K) and adjusted front-rear using the knobs (3:J).

The seat is equipped with a safety switch that is connected to the machine's safety system. This means that certain dangerous activities are not possible when there is nobody in the seat.

2.4.12 Engine casing (4:L)

To access the fuel cock, battery and engine the engine is equipped with engine casing that can be opened. The engine casing is locked by a rubber strap.

The engine casing is opened as follows:

1. Detach the rubber strap (4:M) at the front edge of the engine casing.
2. Carefully lift the engine casing back.

Close in reverse order.



The machine may not be operated unless the engine casing is folded down and locked. Risk of burns and crushing injuries.

3 AREAS OF USE

The machine may only be used for the following tasks using the genuine STIGA accessories stated.

Operation	Accessories, STIGA original
Mowing	With cutting deck 95 C (all). With cutting deck 105 C (only HST with 15.5 hp engine and 4WD).
Snow clearance	With snow blade. Snow chains and frame weights recommended.
Grass clipping and leaf collection	With towed collector 30" or 42".
Grass and leaf transport	With dump cart Standard, Maxi or Combi.

The maximum vertical load on the towing hitch must not exceed 100 N.

The maximum over-run load on the towing hitch from towed accessories must not exceed 500 N.

NOTE! Before using a trailer – contact your insurance company.

NOTE! This machine is not intended to be driven on public roads.

4 STARTING AND OPERATION



The machine may not be operated unless the engine casing is closed and locked. Risk of burns and crushing injuries.

4.1 Filling with petrol (7:Q)

Always use lead-free petrol. You must never use 2-stroke petrol mixed with oil.

The tank holds 6 litres. The level can easily be read through the transparent tank.

NOTE! Ordinary lead-free petrol is a perishable and must not be stored for more than 30 days.

Environmental petrol can be used, i.e. alkylate petrol. This type of petrol has a composition that is less harmful for people and nature.



Petrol is highly inflammable. Always store fuel in containers that are made especially for this purpose.



Only fill or top up with petrol outdoors, and never smoke when filling or topping up. Fill up with fuel before starting the engine. Never remove the filler cap or fill with petrol while the engine is running or still warm.

Never completely fill the petrol tank. Leave an empty space (= at least the entire filler tube plus 1 - 2 cm at the top of the tank) to allow the petrol to expand when it warms up without overflowing. See fig. 7.

4.2 Checking the engine oil level

On delivery, the crankcase is filled with SAE 10W-40 oil.

Check the oil level every time before using to ensure it is correct. The machine should be standing on level ground.



Wipe clean around the oil dipstick. Unscrew and pull it up. Wipe off the dipstick. Slide it down completely and tighten it.

Then unscrew it and pull it up again. Read off the oil level. Top up with oil to the "FULL" mark, if the level comes below it. See fig. 8.

The oil level must never exceed the "FULL" mark. This results in the engine overheating. If the oil level exceeds the "FULL" mark, the oil must be drained until the correct level is achieved.

4.3 Checking transmission oil level

Check the oil level every time before using to ensure it is correct. The machine should be standing on level ground.

Read off the oil level in the reservoir (9:R). It should be between the MAX and MIN marks. If necessary, top up with more oil.

Type of oil:

	Oil type
4WD	Synthetic oil 5W-50
HST	SAE 10W-40 (20W-50)

4.4 Safety checks

Check that the results of the safety checks below are achieved when testing the machine in question.



The safety checks must always be carried out every time before use.



If any of the results below is not achieved, the machine must not be used! Take the machine to a service workshop for repair.

4.4.1 General safety check

Object	Result
Fuel lines and connections.	No leaks.
Electrical cables.	All insulation intact. No mechanical damage.
Exhaust system.	No leaks at connections. All screws tightened.
Oil lines	No leaks. No damage.
Drive the machine forwards/backwards and release the driving-service brake pedal.	The machine will stop.
Test driving	No abnormal vibrations. No abnormal sound.

4.4.2 Electrical safety check



The operation of the safety system should always be checked every time before use.

Status	Action	Result
Only HST, 4WD. The clutch-brake pedal not depressed. Power take-off not activated.	Attempt to start.	The engine must not start.
Only Man, Gear lever not in neutral.	Attempt to start.	The engine must not start.
Engine running. Power take-off activated.	The operator leaves the seat.	The power take-off must disengage.
Engine running.	Remove the fuse. See 9:S.	The engine must stop.

4.5 Start

1. Open the fuel cock. See 10:U.
2. Check that the spark plug cable(s) is/are installed on the spark plug(s).
3. Check to make sure that the power take-off is disengaged.
- 4a. **Compact, Man:** Put the gear lever in neutral.
- 4b. **Compact HST, 4WD:** Do not keep your foot on the drive pedal.
5. Starting cold engine – put the throttle control in the choke position.
Starting warm engine – put the throttle control at full throttle (approx. 2 cm behind the choke position).
6. Depress the clutch-brake pedal fully.

7. Turn the ignition key and start the engine.
 8. Once the engine has started, move the throttle control gradually to full throttle (approx. 2 cm behind the choke position) if the choke has been used.
 9. When starting from cold, do not make the machine work under load immediately, but let the engine run for a few minutes first. This will allow the oil to warm up.
- When the machine is in operation, full throttle should always be used.

4.6 Operating tips

Always check that there is the correct volume of oil in the engine. This is particularly important when operating on slopes. See 4.2.



Be careful when driving on slopes. No sudden starting or stopping when driving up or down a slope. Never drive across a slope. Move from the top down or from the bottom to the top.



The machine may not be driven on slopes greater than 10° in any direction.



Reduce the speed on slopes and when making sharp turns in order to retain control and reduce the risk of tipping over.



Do not turn the steering wheel to full lock when driving in top gear and at full throttle. The machine can easily topple over.



Keep hands and fingers well away from articulated steering joint and seat bracket. Risk of crushing injuries. Never drive with the engine casing open.

4.7 Stop

Disengage the power take-off. Apply the parking brake.

Allow the engine to idle 1-2 mins. Stop the engine by turning off the ignition key.

Shut off the petrol cock. This is particularly important if the machine is to be transported on a trailer for example.



If the machine is left unattended, remove the spark plug cable(s) and remove the ignition key.



The engine may be very warm immediately after it is shut off. Do not touch the silencer, cylinder or cooling fins. This can cause burn injuries.

4.8 Cleaning



To reduce the risk of fire, keep the engine, silencer, battery and fuel tank free from grass, leaves and oil.



To reduce the risk of fire, regularly check the machine for oil and/or fuel leakage.

Clean the machine after each use. The following instructions apply for cleaning:

- When washing the machine with water under high pressure, do not point the jet directly at axle seals, electrical components or hydraulic valves.
- Do not spray water directly at the engine.
- Clean the engine with a brush and/or compressed air.
- Clean the engine's cooling air intake (9:T).

5 MAINTENANCE

5.1 Service programme

In order to keep the machine in good condition as regards reliability and operational safety as well as from an environmental perspective, STIGA's Service programme should be followed.

The contents of this programme can be found in the attached service log.

Basic service must always be carried out by an authorised workshop.

First service and intermediate service should be carried out by an authorised workshop, but can also be carried out by the user. The content of this can be found in the service log and the actions are described under "4 STARTING AND OPERATION" as well as below.

Servicing carried out at an authorised workshop guarantees professional work using genuine spare parts.

At each basic service and intermediate service carried out at an authorised workshop, the service log is stamped. A service log presenting these services is a valuable document that improves the machine's second-hand value.

5.2 Preparation

All service and all maintenance must be carried out on a stationary machine with the engine switched off.



Prevent the machine from rolling by always applying the parking brake.



Stop the engine.



Prevent unintentional starting of the engine by disconnecting the spark plug cable(s) from the spark plug(s) and removing the ignition key.

5.3 Tyre pressure

Adjust the air pressure in the tyres as follows:

Front: 0.6 bar (9 psi).

Rear: 0.4 bar (6 psi).

5.4 Changing engine oil

Change engine oil for the first time after 5 hours of operation, and subsequently after every 50 hours of operation or once a season.

Change the oil more often (after 25 hours of operation or at least once a season) if the engine has to operate under demanding conditions or if the ambient temperature is high.

Use synthetic oil of service grade SF or higher in accordance with the table below.

Use	Oil
All temperatures	SAE 10W-40
Below -18°C	SAE 5W-30
Above 0°C	SAE 30

Use oil without any additives.

Do not fill with too much oil. This can cause the engine to overheat.

Change oil when the engine is warm.



The engine oil may be very hot if it is drained off directly after the engine is shut off. Therefore allow the engine to cool a few minutes before draining the oil.

1. Attach the clamp on the oil drainage hose. Use a polygrip or similar. See fig. 10:V.
2. Move the clamp up 3-4 cm on the oil drainage hose and pull out the plug.
3. Collect the oil in a collection vessel.
NOTE! Do not spill any oil on the drive belts.
4. Hand in the oil for disposal in accordance with local provisions.
5. Install the oil drainage plug and move the clamp back so that it clamps above the plug.
6. Remove the dipstick and fill up with new oil.
Oil volume: 1.4 litres
7. After filling up the oil, start the engine and idle for 30 seconds.
8. Check to see if there is any oil leakage.
9. Stop the engine. Wait for 30 seconds and then check the oil level in accordance with 4.2.

5.5 Transmission, oil (4WD)

The oil in the hydraulic power transmission must be checked/adjusted and changed at the intervals given in the table below.

Action	1st time	Then at intervals of
	Hours of operation	
Checking – adjusting level.	-	50
Changing the oil.	5	200

Type of oil: Synthetic oil 5W-50

Oil quantity when changing: approximately 3.5 litres.

5.5.1 Checking - adjusting

See "4.2".

5.5.2 Draining

1. Run the machine at variable speeds for 10-20 minutes to heat up the transmission oil.
2. Position the machine completely horizontally.
3. Pull out both disengagement levers according to fig. 6.
4. Place one container under the rear axle and one under the front axle.
5. Open the oil reservoir by removing the cover. See 9:R.



Only a 3/8" square drive may be used for the oil plug. Other tools will damage the plug.

6. Remove the oil plug from the rear axle. Clean the hole and use a 3/8" square drive. See figure 11.
7. Remove 2 drain plugs from the front axle. Use a 12 mm socket. Allow the oil in the front axle and pipes to run out. See fig. 12.
8. Check that the gaskets on the drain plugs of the front axle are intact. See fig. 12. Reinstall the plugs. Tightening torque: 15-17 Nm.



The oil plug will be damaged if it is tightened more to than 5 Nm.

9. Check that the gasket on the oil plug of the rear axle is intact. See fig. 11:Y. Reinstall in the rear axle. Tighten the oil plug to 5 Nm.
10. Draw out the oil from the deeper section of the reservoir using an oil extractor. See fig. 13.
11. Dispose of the oil according to local regulations.

5.5.3 Filling



The engine must never be run when the rear clutch release lever is pushed in and the front clutch release lever is pulled out.

This will damage the front axle seals.

1. Fill the oil reservoir with the new oil.



If the engine is run indoors, exhaust extraction equipment must be connected to the engine's exhaust pipe.

2. Check that the rear axle's clutch release lever is pulled out.
3. Start the engine. When the engine is started, the front axle's clutch release lever slides inwards automatically.
4. Pull out the front axle's clutch release lever.
NOTE! The oil is drawn into the system very quickly. The reservoir must always be topped up. Air must never be drawn in.
5. Set the accelerator pedal to the forward position by blocking it using a wooden wedge. See fig. 14. Fill the oil reservoir by hand using new oil.
6. Run in the forward position for one minute.
7. Move the wooden wedge and set the accelerator pedal to the reverse position. Continue filling with oil.
8. Run in reverse mode for one minute.
9. Change driving direction once every minute as above and continue filling with oil until the bubbling in the reservoir stops.
10. Switch off the engine, install the oil reservoir cover and close the engine cover.
11. Test drive for several minutes and adjust the oil level in the reservoir.

5.6 Belt transmissions

After 5 hours of operation, check that all the belts are intact and undamaged.

5.7 Steering

The steering must be checked/adjusted after 5 hours of operation and thereafter after 100 hours of operation.

5.7.1 Checks

Briefly turn the steering wheel back and forth. There must be no mechanical clearance in the steering chains.

5.7.2 Adjustment

Adjust the steering chains if required as follows:

1. Put the machine in the straight-ahead position.
2. Adjust the steering chains with the two nuts, located under the central point. See fig. 16.
3. Adjust both nuts by the same amount until there is no clearance.
4. Test drive the machine straight forwards and check that the steering wheel is not off centre.
5. If the steering wheel is off centre, undo one nut and tighten the other.

Do not over-tighten the steering chains. This will cause the steering to become heavy and will increase wear on the steering chains.

5.8 Battery



If acid comes into contact with the eyes or skin, this can cause serious injuries. If any part of the body has come into contact with acid, rinse immediately with copious amounts of water and seek medical assistance as soon as possible.

The battery is a valve-regulated battery with 12 V nominal voltage. The battery fluid does not need to and cannot be checked or topped up. The only maintenance that is required is charging, for example after extended storage.



The battery must be fully charged before being used for the first time. The battery must always be stored fully charged. If the battery is stored while discharged, serious damage will occur.

5.8.1 Charging with the engine

The battery can be charged using the engine's generator as follows:

1. Install the battery in the machine as shown below.
2. Place the machine outdoors or install an extraction device for the exhaust fumes.
3. Start the engine according to the instructions in the user guide.
4. Allow the engine to run continuously for 45 minutes.
5. Stop the engine. The battery will now be fully charged.

5.8.2 Charging using battery charger

When charging using a battery charger, a battery charger with constant voltage must be used.

Contact your dealer to purchase a battery charger with constant voltage.

The battery can be damaged if a standard type battery charger is used.

5.8.3 Removal/Installation

The battery is placed under the engine casing. During removal/installation, the following applies regarding connection of the cables:

- During removal. First disconnect the black cable from the battery's negative terminal (-). Then disconnect the red cable from the battery's positive terminal (+).
- During installation. First connect the red cable to the battery's positive terminal (+). Then connect the black cable to the battery's negative terminal (-).



If the cables are disconnected/connected in the wrong order, there is a risk of a short-circuit and damage to the battery.



If the cables are interchanged, the generator and the battery will be damaged.



Tighten the cables securely. Loose cables can cause a fire.



The engine must never be driven with the battery disconnected. There is a risk of serious damage to the generator and the electrical system.

5.8.4 Cleaning

If the battery terminals are coated with oxide, they should be cleaned. Clean the battery terminals with a wire brush and lubricate them with terminal grease.

5.9 Air filter, engine

The pre-filter (foam filter) must be cleaned/replaced after 25 hours of operation.

The air filter (paper filter) must be cleaned/replaced after 100 hours of operation.

NOTE! The filters should be cleaned/replaced more often if the machine operates on dusty ground.

Remove/install the air filters as follows.

1. Clean carefully around the air filter cover.
2. Dismantle the air filter cover (15:A) by removing the two clamps.
3. Dismantle the filter assembly (15:B). The pre-filter is placed over the air filter. Make sure that no dirt gets into the carburettor. Clean the air filter housing.

4. Clean the paper filter by tapping it gently against a flat surface. If the filter is very dirty, replace it.
5. Clean the pre-filter. If the filter is very dirty, replace it.
6. Assemble in the reverse order.

Compressed air or petroleum-based solvents such as kerosene may not be used for cleaning the paper filter insert. This will damage the filter.

5.10 Spark plug

The spark plug(s) must be replaced every 200 hours of operation (=at every other basic service). Before disconnecting the spark plug, clean around its mounting.

Spark plug: Champion RC12YC or equivalent.

Electrode distance: 0.75 mm.

5.11 Air intake

See 19:T. The engine is air-cooled. A blocked cooling system can damage the engine. Clean the engine's air intake after 50 hours of operation. More meticulous cleaning of the cooling system is carried out during each basic service.

5.12 Lubrication

All lubrication points in accordance with the table below must be lubricated every 50 hours of operation as well as after every wash.

Object	Action	Figure
Wheel bearing	2 grease nipples. Use a grease gun filled with universal grease. Pump until the grease emerges.	17
Centre point	4 grease nipples. Use a grease gun filled with universal grease. Pump until the grease emerges.	18
Steering chains	Brush the chains clean with a wire brush. Lubricate with universal chain spray.	-
Tensioning arms	Lubricate the bearing points with an oil can when each control is activated. Ideally carried out by two people.	19
Control cables	Lubricate the cable ends with an oil can when each control is activated. Must be carried out by two people.	20

5.13 Fuse

In the event of electrical faults, check/replace the fuse, 20 A. See 9:S.

6 PATENT - DESIGN REGISTRATION

This machine or parts thereof is covered by the following patent and design registration:
SE9901091-0, SE9901730-3, SE9401745-6,
US595 7497, FR772384, DE69520215.4,
GB772384, SE0301072-5, SE04/000239 (PCT),
SE0401554-1, SE0501599-5.

GGP reserves the right to make alterations to the product without prior notification.



www.stiga.com

GGP Sweden AB · Box 1006 · SE-573 28 TRANÅS

Free Manuals Download Website

<http://myh66.com>

<http://usermanuals.us>

<http://www.somanuals.com>

<http://www.4manuals.cc>

<http://www.manual-lib.com>

<http://www.404manual.com>

<http://www.luxmanual.com>

<http://aubethermostatmanual.com>

Golf course search by state

<http://golfingnear.com>

Email search by domain

<http://emailbydomain.com>

Auto manuals search

<http://auto.somanuals.com>

TV manuals search

<http://tv.somanuals.com>