

SUPERO[®]

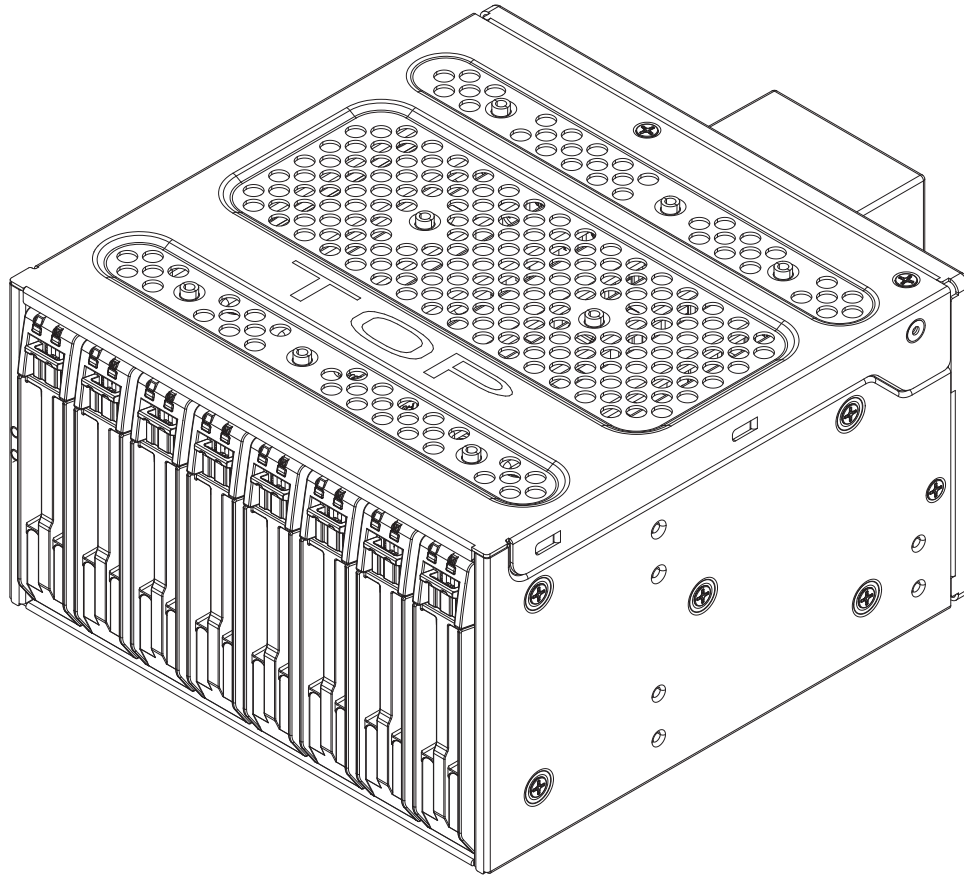

M28SAB/M28SAB-OEM

MOBILE RACK

USER'S GUIDE

Rev. 1.0

The information in this User's Manual has been carefully reviewed and is believed to be accurate. The vendor assumes no responsibility for any inaccuracies that may be contained in this document, makes no commitment to update or to keep current the information in this manual, or to notify any person or organization of the updates. **Please Note: For the most up-to-date version of this manual, please see our web site at www.supermicro.com.**

Super Micro Computer, Inc. ("Supermicro") reserves the right to make changes to the product described in this manual at any time and without notice. This product, including software and documentation, is the property of Supermicro and/or its licensors, and is supplied only under a license. Any use or reproduction of this product is not allowed, except as expressly permitted by the terms of said license.

IN NO EVENT WILL SUPERMICRO BE LIABLE FOR DIRECT, INDIRECT, SPECIAL, INCIDENTAL, SPECULATIVE OR CONSEQUENTIAL DAMAGES ARISING FROM THE USE OR INABILITY TO USE THIS PRODUCT OR DOCUMENTATION, EVEN IF ADVISED OF THE POSSIBILITY OF SUCH DAMAGES. IN PARTICULAR, SUPERMICRO SHALL NOT HAVE LIABILITY FOR ANY HARDWARE, SOFTWARE, OR DATA STORED OR USED WITH THE PRODUCT, INCLUDING THE COSTS OF REPAIRING, REPLACING, INTEGRATING, INSTALLING OR RECOVERING SUCH HARDWARE, SOFTWARE, OR DATA.

Any disputes arising between manufacturer and customer shall be governed by the laws of Santa Clara County in the State of California, USA. The State of California, County of Santa Clara shall be the exclusive venue for the resolution of any such disputes. Super Micro's total liability for all claims will not exceed the price paid for the hardware product.

California Best Management Practices Regulations for Perchlorate Materials: This Perchlorate warning applies only to products containing CR (Manganese Dioxide) Lithium coin cells. "Perchlorate Material-special handling may apply. See www.dtsc.ca.gov/hazardouswaste/perchlorate"

WARNING: Handling of lead solder materials used in this product may expose you to lead, a chemical known to the State of California to cause birth defects and other reproductive harm.

Manual Revision 1.0
Release Date: June 7, 2011

Unless you request and receive written permission from Super Micro Computer, Inc., you may not copy any part of this document.

Information in this document is subject to change without notice. Other products and companies referred to herein are trademarks or registered trademarks of their respective companies or mark holders.

Copyright © 2011 by Super Micro Computer, Inc.
All rights reserved.

Printed in the United States of America

Table of Contents

Contacting Supermicro.....	iv
Returning Merchandise for Service.....	v
Chapter 1 Safety Guidelines	1-1
1-1 ESD Safety Guidelines	1-1
1-2 General Safety Guidelines	1-1
1-3 An Important Note to Users	1-2
Chapter 2 Introduction.....	2-1
2-1 Overview	2-1
2-2 Product Features	2-1
Operating Systems.....	2-1
Additional Information	2-2
Chapter 3 SAS-I28A Backplane Specifications	3-1
3-1 Front Connectors and Jumpers	3-1
3-2 Front Components, Connectors and Pin Definitions	3-2
3-3 Front Jumper Locations and Pin Definitions.....	3-3
Explanation of Jumpers	3-3
3-4 Rear Connectors and LED Indicators	3-4
Chapter 4 Mobile Rack Installation Instructions.....	4-1
4-1 Shipping List.....	4-1
4-2 Tools Required	4-1
4-3 Other Parts.....	4-1
4-4 Setup and Installation Steps	4-2
4-5 General Safety Guidelines	4-2
4-6 Before Accessing the Mobile Rack	4-2
4-7 Cooling Fan Installation	4-3
Installing the Cooling Fan	4-3
Fan Removal.....	4-3
4-8 Hard Drive Installation.....	4-4
4-9 Connect Data and Power Cables	4-6
4-10 Advanced Configuration.....	4-6

Contacting Supermicro

Headquarters

Address: Super Micro Computer, Inc.
980 Rock Ave.
San Jose, CA 95131 U.S.A.

Tel: +1 (408) 503-8000
Fax: +1 (408) 503-8008
Email: marketing@supermicro.com (General Information)
support@supermicro.com (Technical Support)

Web Site: www.supermicro.com

Europe

Address: Super Micro Computer B.V.
Het Sterrenbeeld 28, 5215 ML
's-Hertogenbosch, The Netherlands

Tel: +31 (0) 73-6400390
Fax: +31 (0) 73-6416525
Email: sales@supermicro.nl (General Information)
support@supermicro.nl (Technical Support)
rma@supermicro.nl (Customer Support)

Asia-Pacific

Address: Super Micro Computer, Inc.
4F, No. 232-1, Liancheng Rd.
Chung-Ho 235, Taipei County
Taiwan, R.O.C.

Tel: +886-(2) 8226-3990
Fax: +886-(2) 8226-3991
Web Site: www.supermicro.com.tw

Technical Support:
Email: support@supermicro.com.tw
Tel: 886-2-8226-1900

Returning Merchandise for Service

A receipt or copy of your invoice marked with the date of purchase is required before any warranty service will be rendered. You can obtain service by calling your vendor for a Returned Merchandise Authorization (RMA) number. When returning to the manufacturer, the RMA number should be prominently displayed on the outside of the shipping carton, and mailed prepaid or hand-carried. Shipping and handling charges will be applied for all orders that must be mailed when service is complete.

For faster service, RMA authorizations may be requested online (<http://www.supermicro.com/support/rma/>).

Whenever possible, repack the mobile rack in the original Supermicro carton, using the original packaging material. If these are no longer available, be sure to pack the mobile rack securely, using packaging material to surround the mobile rack so that it does not shift within the carton and become damaged during shipping.

This warranty only covers normal consumer use and does not cover damages incurred in shipping or from failure due to the alteration, misuse, abuse or improper maintenance of products.

During the warranty period, contact your distributor first for any product problems.

Notes

Chapter 1

Safety Guidelines

To avoid personal injury and property damage, carefully follow all the safety steps listed below when accessing your system or handling the components.

1-1 ESD Safety Guidelines

Electrostatic Discharge (ESD) can damage electronic components. To prevent damage to your system, it is important to handle it very carefully. The following measures are generally sufficient to protect your equipment from ESD.

- Use a grounded wrist strap designed to prevent static discharge.
- Touch a grounded metal object before removing a component from the antistatic bag.
- Handle the mobile rack backplane by its edges only; do not touch its components, peripheral chips, memory modules or gold contacts.
- When handling chips or modules, avoid touching their pins.
- Put the card and peripherals back into their antistatic bags when not in use.

1-2 General Safety Guidelines

- Always disconnect power cables before installing or removing any components from the computer, including the backplane.
- Disconnect the power cable before installing or removing any cables from the backplane.
- Make sure that the backplane is securely and properly installed on the motherboard to prevent damage to the system due to power shortage.

1-3 An Important Note to Users

All images and layouts shown in this user's guide are based upon the latest equipment and PCB revision available at the time of publishing. The card and equipment you have received may or may not look exactly the same as the graphics shown in this manual.

Chapter 2

Introduction

2-1 Overview

This manual has been written for system integrators, PC technicians and knowledgeable PC users. It provides detailed information for the installation and use of the M28SAB mobile rack.

The Supermicro M28SAB mobile rack showcases advanced technology innovations in modular connectivity and data transferability and supplies reliable, effective, and scalable solutions for tomorrow's data communications industry.

2-2 Product Features

The M28SAB mobile rack includes the following:

- Slim design: pocket-size (5-3/4" width x 3-3/8" height).
- Supports a 8 x 2.5" small form factor hard disk drive.
- Supports up to 5V/10A (average) and 12V/10A (average).
- Supports SAS 2.0 and SATA III at 6 Gbps transfer speed.

Operating Systems

This mobile rack supports the following operating systems:

- Windows 2000, Windows XP, Windows 7 and Windows 2003.
- Linux: Red Hat and SuSE.

For the most current information on supported operating systems visit the Supermicro Web site at www.supermicro.com.

Additional Information

The M28SAB mobile rack was designed for use in certain chassis and servers or as an optional unit for storage expansion. Use the chassis or server manual for installation instructions. Use the instructions listed in this manual to use the mobile rack independent of a chassis.

The pictures or graphics shown in this user's guide were based upon the latest revision available at the time of publication of this manual. The M28SAB mobile rack may or may not look exactly the same as the graphics shown in this manual.

The availability of the SAS devices supported depends upon the readiness of firmware and hardware support.

The SAS-I28A mobile rack backplane has been designed to utilize the most up-to-date technology available, providing your system with reliable, high-quality performance.

This manual reflects SAS-I28A Revision 1.00, the most current release available at the time of publication. Always refer to the Supermicro Web site at www.supermicro.com for the latest updates, compatible parts and supported configurations.

Chapter 3

SAS-I28A Backplane Specifications

3-1 Front Connectors and Jumpers

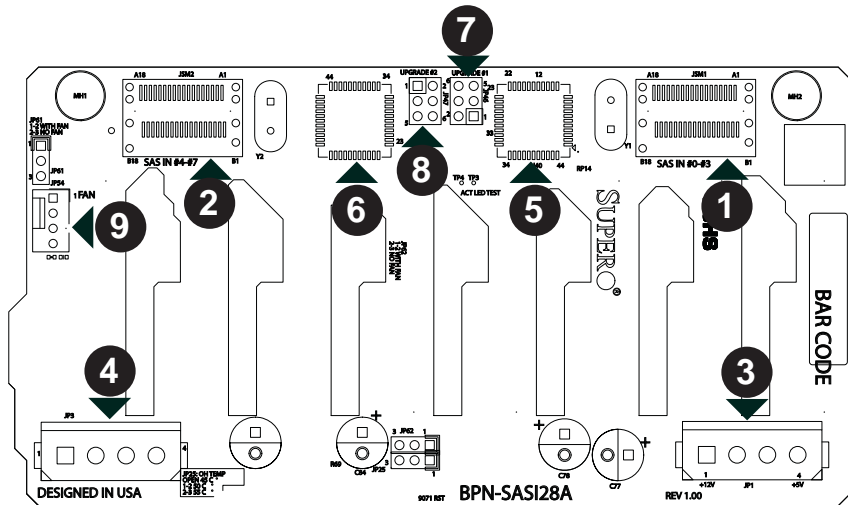

Figure 3-1: Front Connectors and Components

Front Connectors and Components

- | | |
|-------------------------|-------------------------------|
| 1. SAS IN #0 - #3: JSM1 | 6. MG9071 chip |
| 2. SAS IN #4 - #7: JSM2 | 7. Upgrade connector #1: JP46 |
| 3. Power connector: JP1 | 8. Upgrade connector #2: JP47 |
| 4. Power connector: JP3 | 9. Fan connector: JP54 |
| 5. MG9071 chip | |

3-2 Front Components, Connectors and Pin Definitions

#1 - #2 SAS Ports

The SAS ports are used to connect the Mini-SAS cables. The ports are designated SAS IN #0 - #3, and SAS IN #4 - #7. Each port is also compatible with SATA drives.

#3 - #4 Backplane Main Power Connectors

The 4-pin connectors, designated JP1 and JP3, provide power to the backplane. See the table on the right for pin definitions. Both of these connectors must be used at the same time.

Backplane Main Power 4-Pin Connectors	
Pin#	Definition
1	+12V
2 and 3	Ground
4	+5V

#5. - #6. MG9071 Chip

The MG9071 chip is an enclosure management controller chip.

#7 - #8 Upgrade Connector

The upgrade connectors are designated JP46 and JP47. The upgrade connector is for manufacturing use only.

#9 Fan Connectors

The fan connector is designated JP54.

3-3 Front Jumper Locations and Pin Definitions

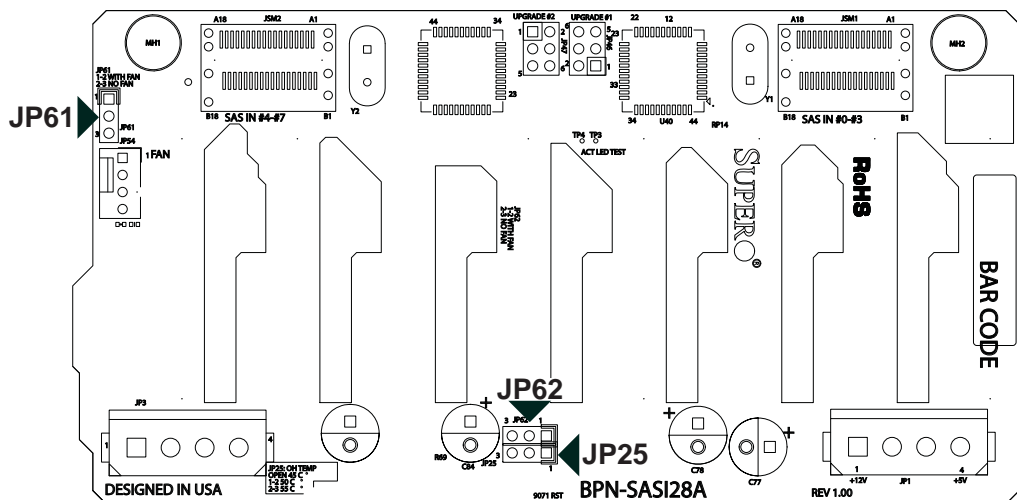
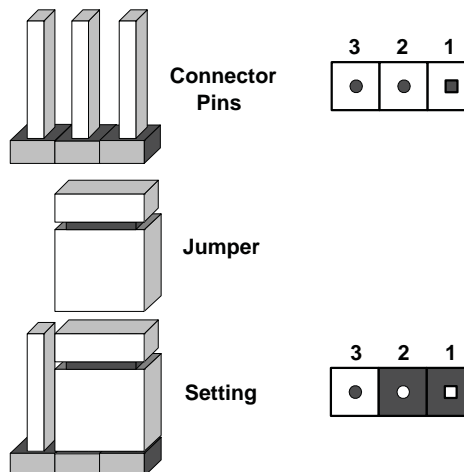

Figure 3-2: Front Jumper

Explanation of Jumpers

To modify the operation of the backplane, jumpers can be used to choose between optional settings. Jumpers create shorts between two pins to change the function of the connector. Pin 1 is identified with a square solder pad on the printed circuit board.

Note: On two-pin jumpers, "Closed" means the jumper is on and "Open" means the jumper is off the pins.



General Jumper Settings		
Jumper	Jumper Settings	Note
JP61	1-2: Fan enabled 2-3: Fan disabled	Enables or disables the fan power.
JP62	1-2: Fan enabled 2-3: Fan disabled	Enclosure monitor enable/disable.
JP25	Open: 45° C 1-2: 50° C 2-3: 55° C	Allows the overheat temperature to be adjusted.

3-4 Rear Connectors and LED Indicators

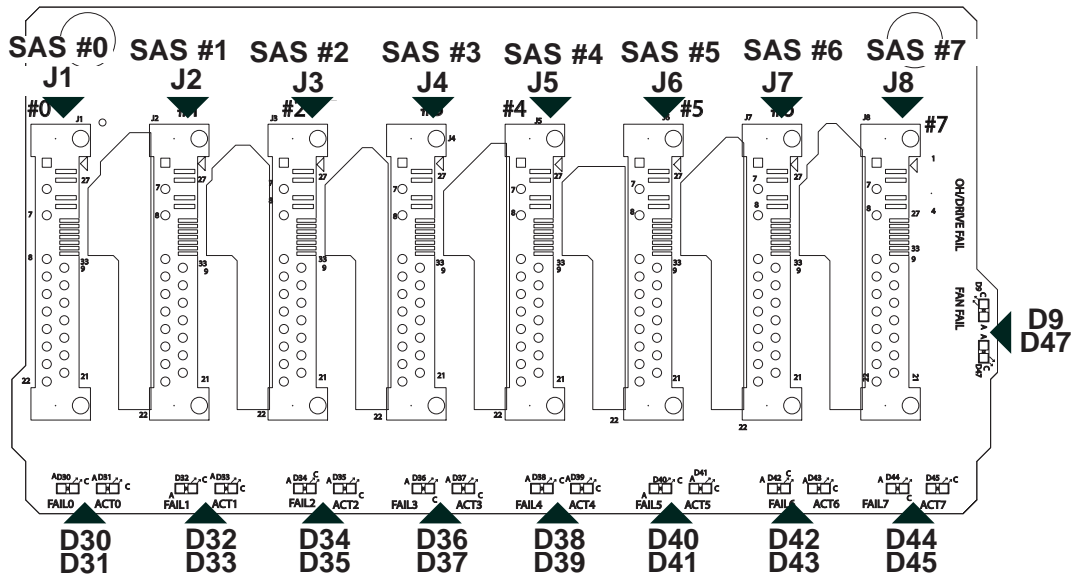

Figure 3-3: Rear Connectors and LED Indicators

Rear LEDs	
LED	Description
D9	OH/DRIVE FAIL
D47	FAN FAIL

Rear SAS/SATA Connectors and LED Indicators			
Rear Connector	Hard Drive Activity LED	Failure LED	SAS Drive
SAS #0	D31	D30	SAS/SATA HDD #0
SAS #1	D33	D32	SAS/SATA HDD #1
SAS #2	D35	D34	SAS/SATA HDD #2
SAS #3	D37	D36	SAS/SATA HDD #3
SAS #4	D39	D38	SAS/SATA HDD #4
SAS #5	D41	D40	SAS/SATA HDD #5
SAS #6	D43	D42	SAS/SATA HDD #6
SAS #7	D45	D44	SAS/SATA HDD #7

Chapter 4

Mobile Rack Installation Instructions

4-1 Shipping Lists for M28SAB and M28SAB-OEM

Examine the your order for the following parts:

M28SAB

- One M28SAB mobile rack
- One 40 mm cooling fan
- Thirty-two M3 screws
- Four round-head screws

M28SAB-OEM

- One M28SAB mobile rack
- Thirty-two M3 screws
- Four round-head screws

4-2 Tools Required

M28SAB series mobile rack assembly requires the following:

- Phillips head screwdriver
- Industry standard anti-static strap (recommended)

4-3 Other Parts

When using this mobile rack independent of a chassis, you may need the following parts.

- Two 4-pin power cords to connect the mobile rack to a power supply.
- SAS iPass cable, part numbers CBL-0108L (39 cm), CBL-0281L (75 cm) or CBL-0294L-01 are used to connect the SAS ports to the motherboard or RAID controller.

4-4 Setup and Installation Steps

Use the following list as a guide to set up and install the mobile rack. If this mobile rack is to be installed in a chassis, use the instructions in the chassis manual.

Mobile Rack Chassis Installation

1. Unpack and examine system parts.
2. Review all system and safety guidelines.
3. M28SAB: Install the system fan as described in section 4-7 of this manual (not required on M28SAB-OEM).
M28SAB-OEM: Reset jumper JP61 to "enable", pins 2 - 3, without the fan connected.
4. Install the hard drives.
5. Connect data and power cables.

4-5 General Safety Guidelines

- Always disconnect power cables before installing or removing any components from the computer, including the backplane.
- Disconnect the power cable before installing or removing any cables from the mobile rack or backplane.

- Make sure that the backplane is securely and properly installed on the motherboard to prevent damage to the system due to power shortage.

4-6 Before Accessing the Mobile Rack

Prior to Accessing the Mobile Rack

1. Power-down and power supply connected to the chassis or server. In addition, unplug all power cords from the wall outlet.
2. Disconnect all necessary cables and label the cables for easy identification.
3. Use a grounded wrist strap designed to prevent static discharge when handling components.
4. Save all screws and fasteners for later use.
5. Familiarize yourself with and follow the instructions in this section.

4-7 Cooling Fan Installation (M28SAB Only)

Installing the Cooling Fan

The M28SAB mobile rack includes a cooling fan (not required on M28SAB-OEM). When using the M28SAB without installing the mobile rack in a larger unit such as a chassis, a cooling fan must be installed on the mobile rack unit.

For more information on installing the mobile rack into a chassis or server, see the documentation for your mobile rack or server. You can also visit our Web site at <http://www.supermicro.com>. Installing the Cooling Fan on the Mobile Rack

1. Align the mounting holes on the fan with the mounting holes in the mobile rack.
2. Attach the cooling fan cable to the fan connector.
3. Secure with two screws as illustrated.

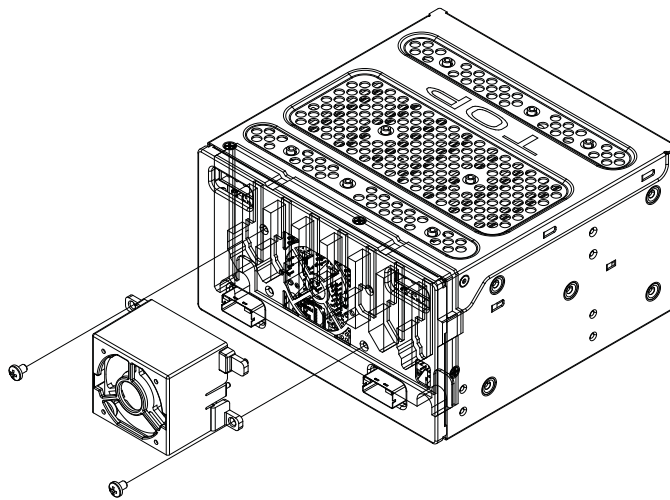

Figure 4-1: Installing the Fan on the M28SAB Mobile Rack

Fan Removal

Removing the Cooling Fan from the Mobile Rack

1. Remove the fan cable from the mobile rack by gently pulling the cable from the backplane.
2. Remove the screws securing the fan to the mobile rack.
3. Pull the fan away from the rear of the mobile rack.

4-8 Hard Drive Installation

Each M28 mobile rack includes dummy trays that act as place holders for hard drives. Before using the mobile rack, you must install hard drives into the drive carriers. Hard drives are sold separately.

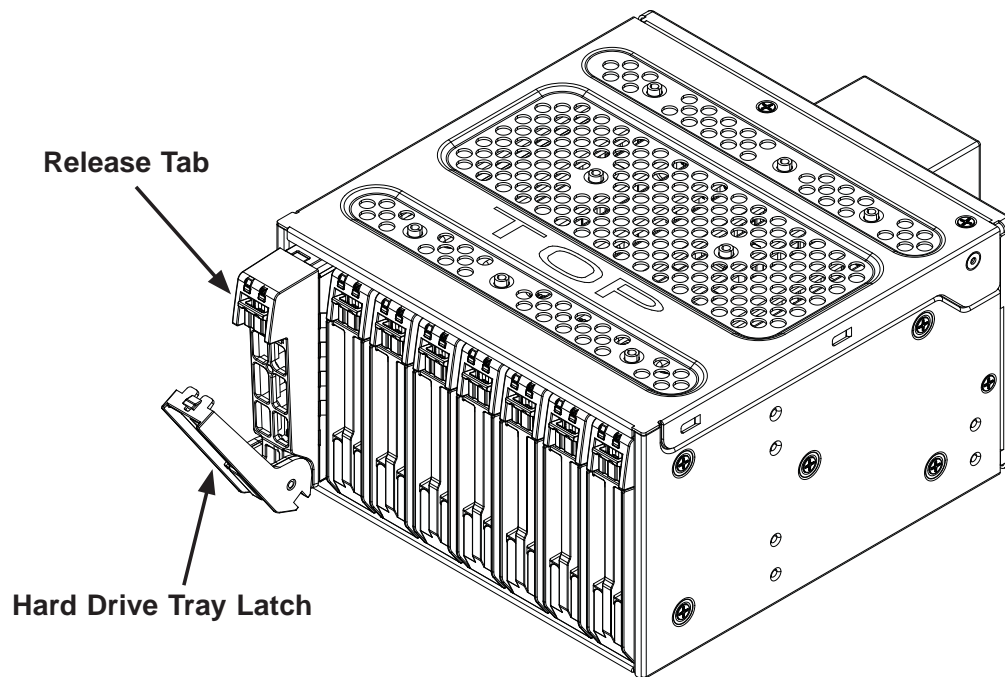

Figure 4-2: Mobile Rack with Hard Drive Trays

Installing Hard Drives into the Mobile Rack

1. Press the release tabs to open the hard drive carrier latch.
2. Using the latch as a handle, pull the drive carrier from the hard drive.



Warning! Enterprise level hard disk drives are recommended for use in Supermicro chassis and servers. For information on recommended HDDs, visit the Supermicro Web site at www.supermicro.com

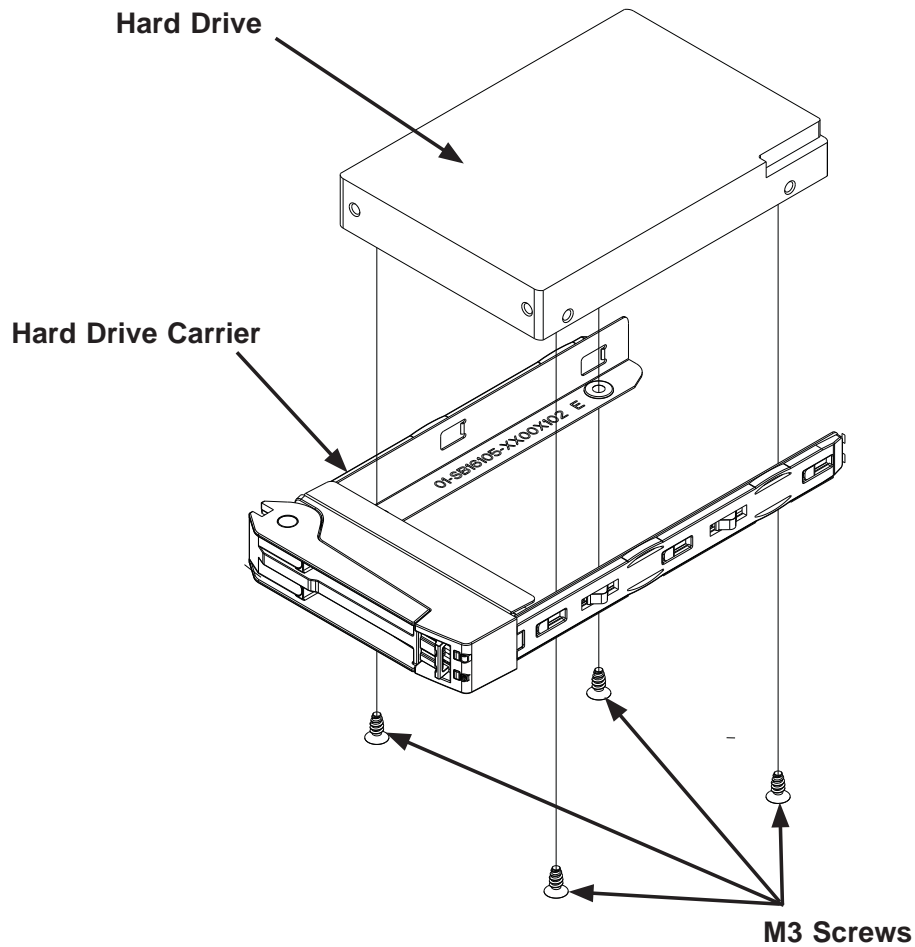

Figure 4-3: Hard Drive and Hard Drive Tray

3. Place a 2.5" hard drive in the hard drive carrier.
4. Align the hard drives to the rear of the hard drive tray.
5. Secure the hard drive to the tray using four M3 screws (as illustrated).
6. Using the hard drive tray latch as a handle, slide the hard drive into the mobile rack.
7. Close the hard drive tray handle to lock the hard drive into place.
8. Repeat steps 1-8 for each hard drive that you will install into the mobile rack.

4-9 Connect Data and Power Cables

Connecting the Cables

1. Connect the SAS cables to the mobile rack. A longer SAS cable may be required (see the recommended cables listed earlier in this manual).
2. Connect the power cables from the chassis power supply. A power cable extension may be required.

4-10 Advanced Configuration

Use the following instructions in the unlikely event that you must access the jumpers, buzzer, or other backplane components.

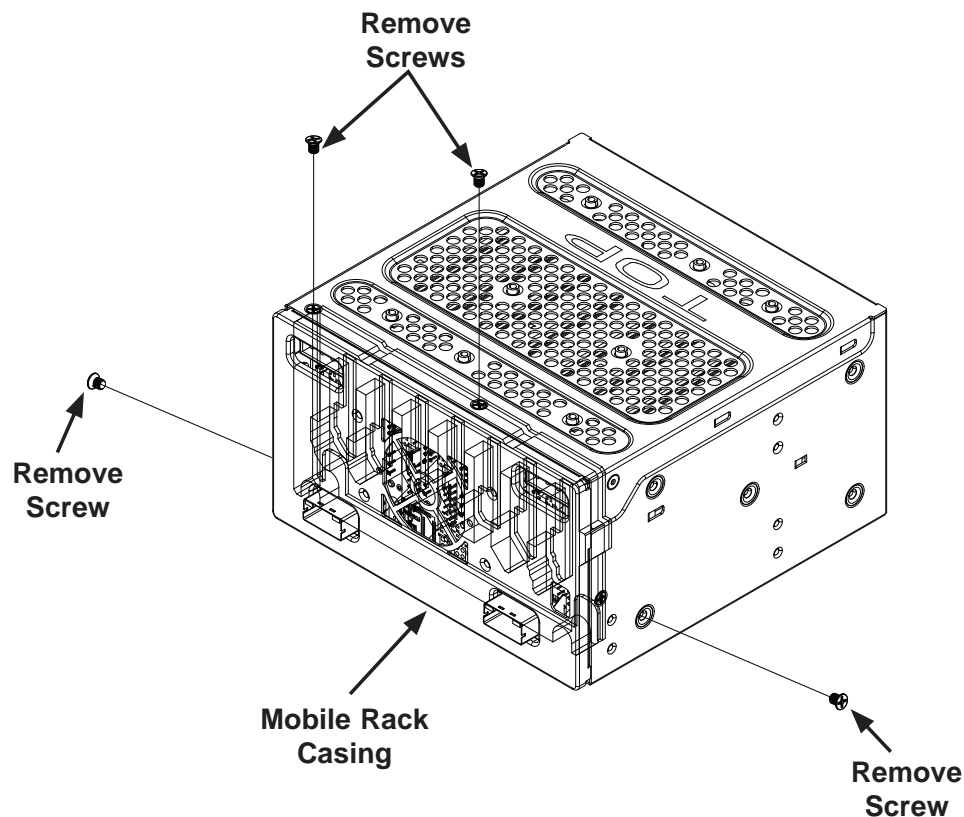

Figure 4-4: Mobile Rack and Rear Casing

Accessing the Mobile Rack Backplane (Optional)

1. Remove the two screws that secure the casing to the mobile rack.
2. Slide the casing downward and remove it from the mobile rack.

Notes

Disclaimer (cont.)

The products sold by Supermicro are not intended for and will not be used in life support systems, medical equipment, nuclear facilities or systems, aircraft, aircraft devices, aircraft/emergency communication devices or other critical systems whose failure to perform be reasonably expected to result in significant injury or loss of life or catastrophic property damage. Accordingly, Supermicro disclaims any and all liability, and should buyer use or sell such products for use in such ultra-hazardous applications, it does so entirely at its own risk. Furthermore, buyer agrees to fully indemnify, defend and hold Supermicro harmless for and against any and all claims, demands, actions, litigation, and proceedings of any kind arising out of or related to such ultra-hazardous use or sale.

Free Manuals Download Website

<http://myh66.com>

<http://usermanuals.us>

<http://www.somanuals.com>

<http://www.4manuals.cc>

<http://www.manual-lib.com>

<http://www.404manual.com>

<http://www.luxmanual.com>

<http://aubethermostatmanual.com>

Golf course search by state

<http://golfingnear.com>

Email search by domain

<http://emailbydomain.com>

Auto manuals search

<http://auto.somanuals.com>

TV manuals search

<http://tv.somanuals.com>