

# RGD3300H RGD5000H

**INSTRUCTIONS FOR USE**  
**MANUAL DE INSTRUCCIONES**

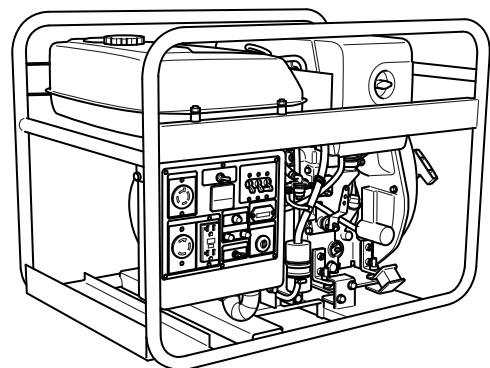

3ZZ9990342

アメリカ

# Robin Generator

1

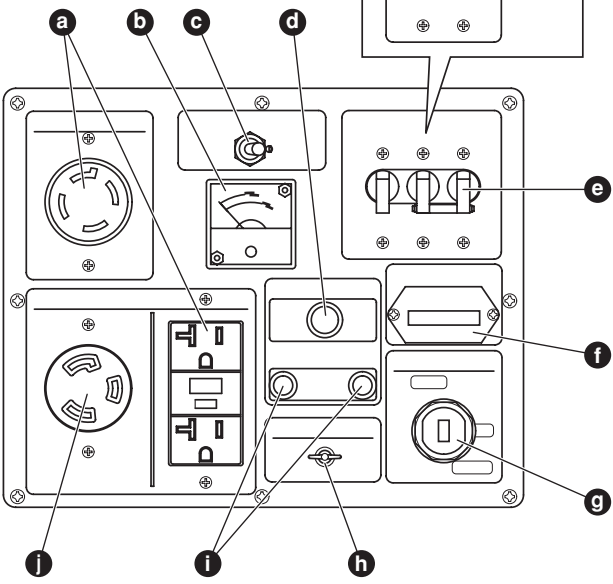
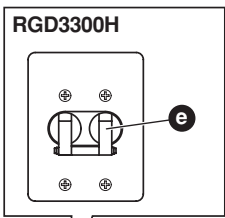
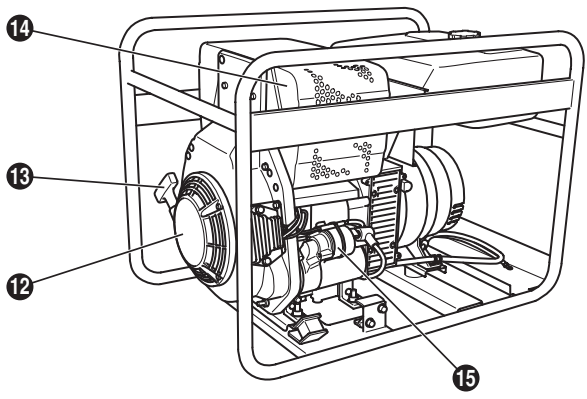
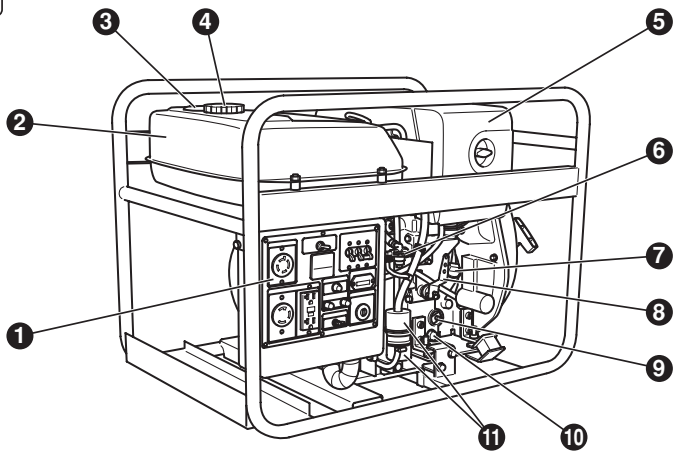

2

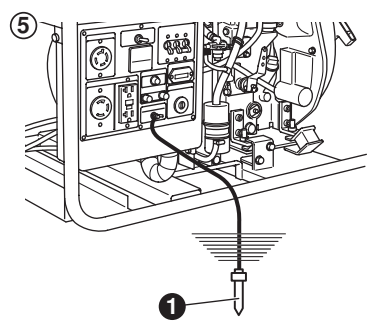
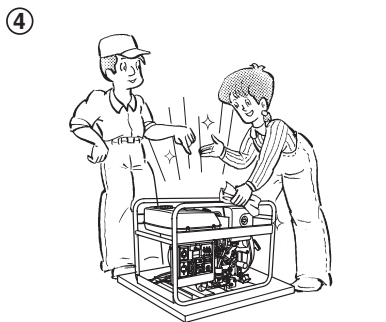
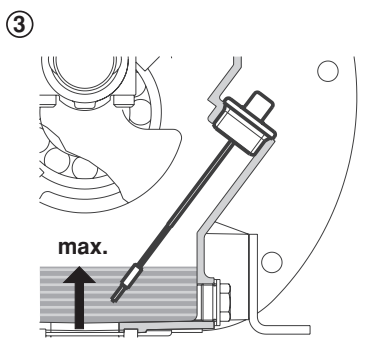
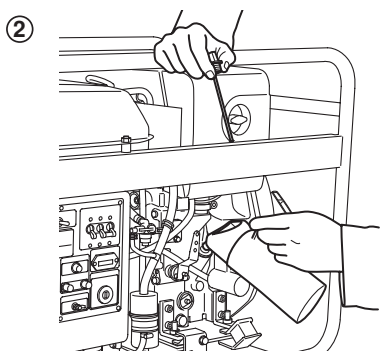
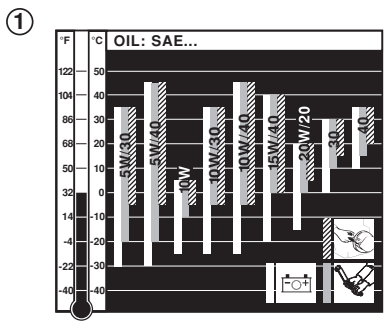

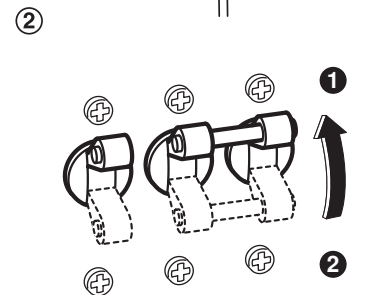
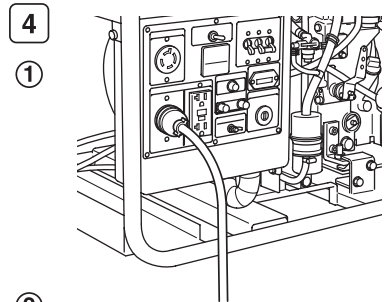
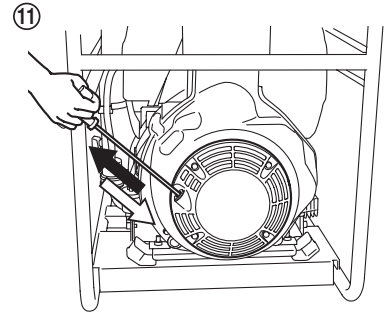
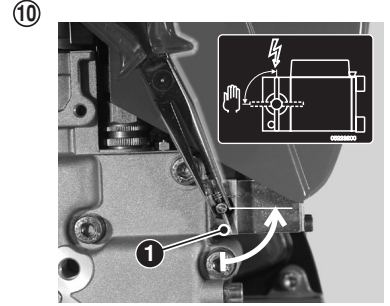
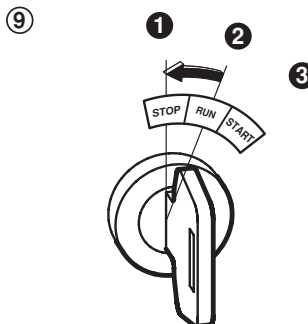
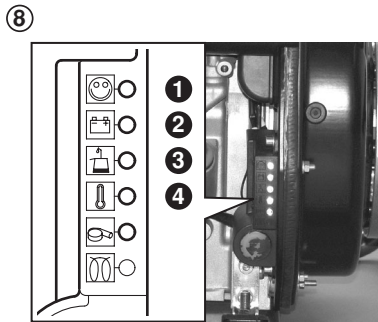
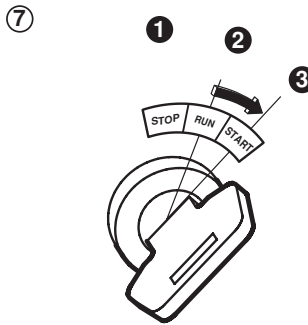
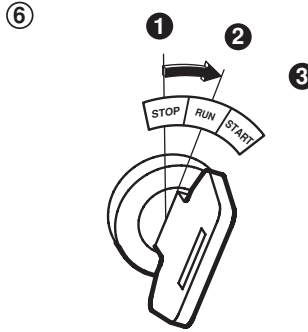
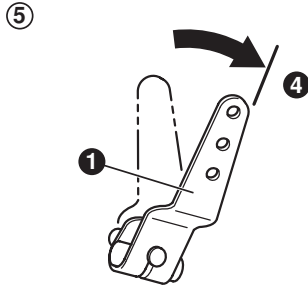
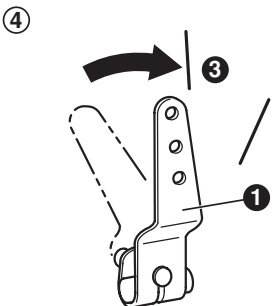
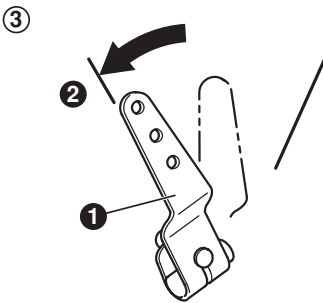
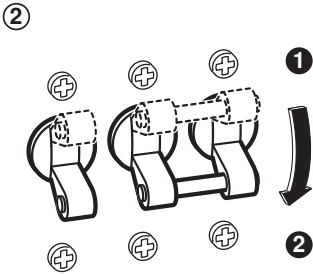
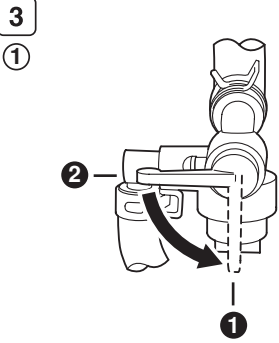
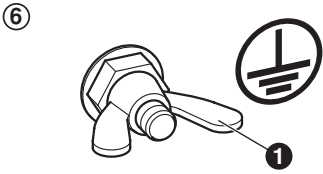

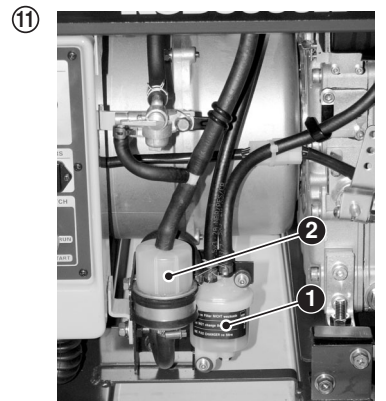
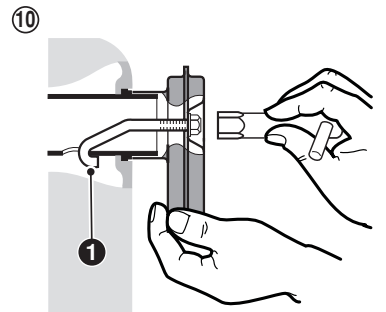
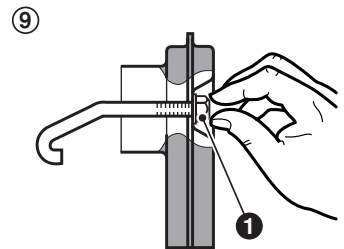
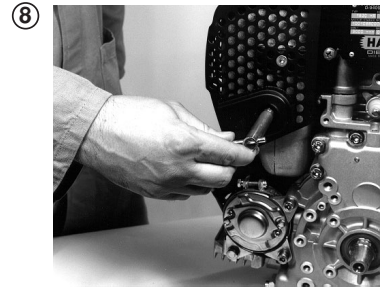
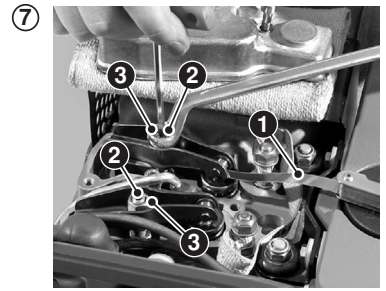
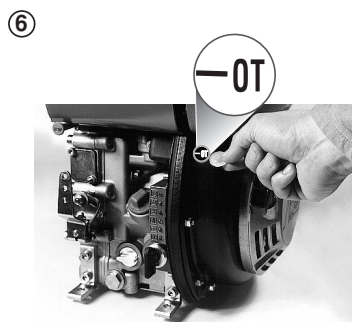
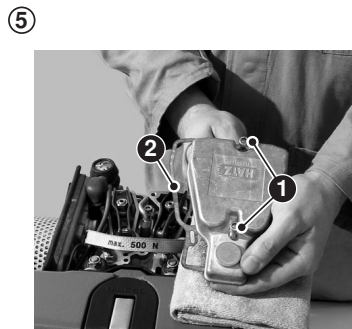
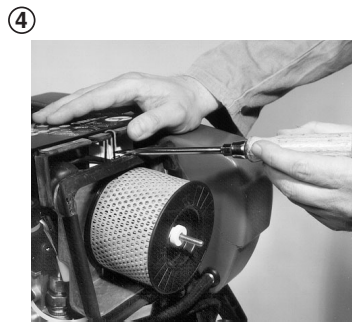
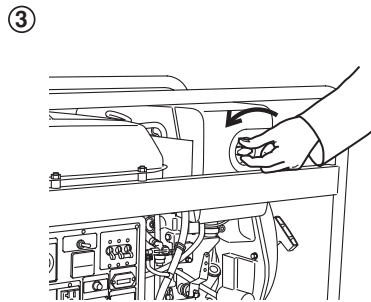
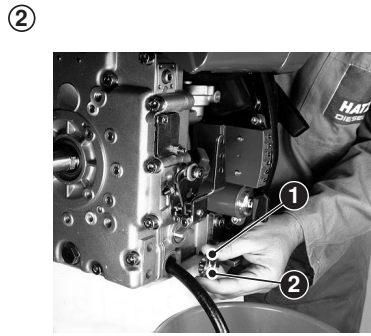
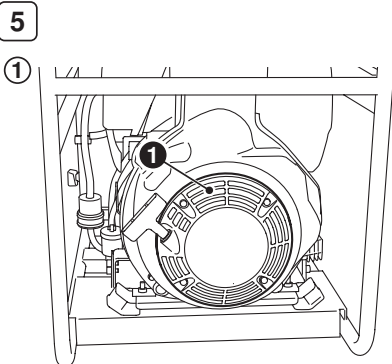
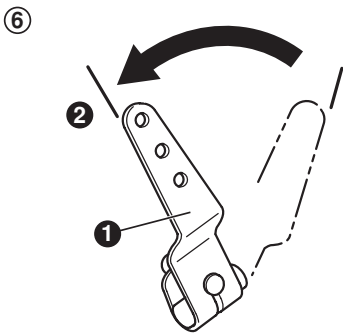
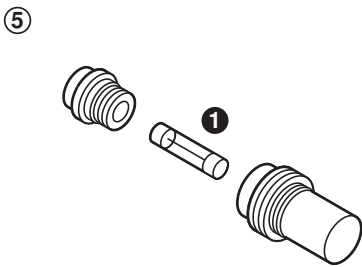
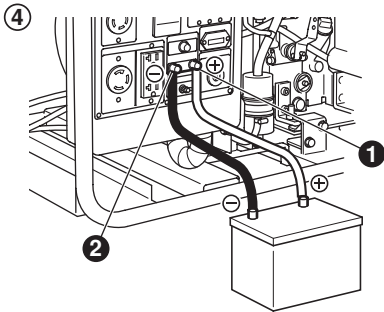
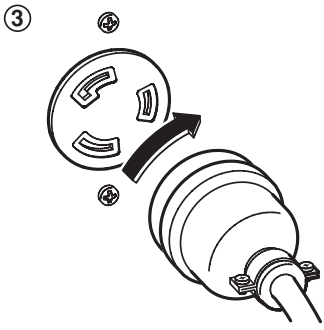

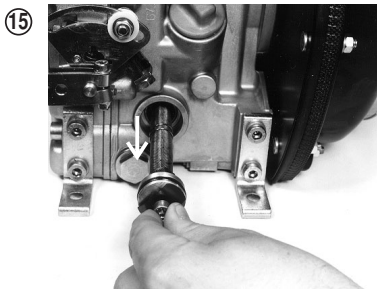
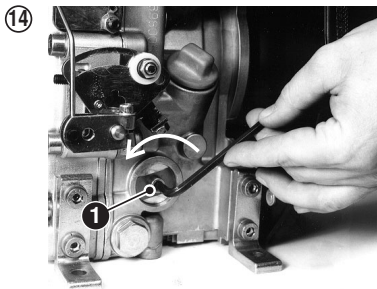
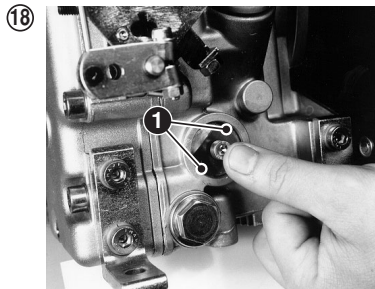
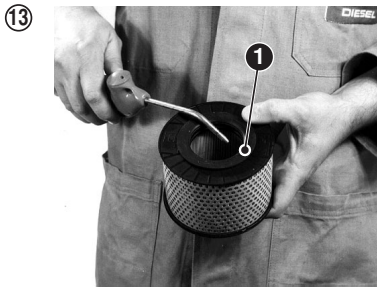
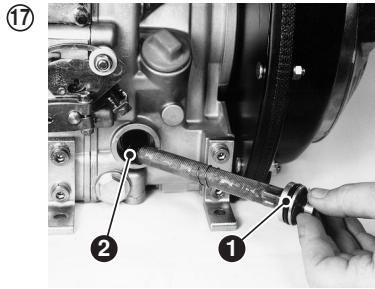
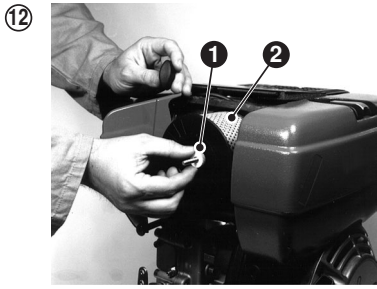

**⚠ DANGER**

Using a generator indoors CAN KILL YOU IN MINUTES.  
Generator exhaust contains carbon monoxide. This is a poison you cannot see or smell.



NEVER use inside a home or garage, EVEN IF doors and windows are open.



Only use OUTSIDE and far away from windows, doors, and vents.

(California Proposition 65)

**⚠ WARNING: ⚠**

The engine exhaust from this product contains chemicals known to the State of California to cause cancer, birth defects or other reproductive harm.

**Notice :** FEDERAL EMISSION COMPONENT DEFECT WARRANTY and CALIFORNIA EMISSION CONTROL WARRANTY are applicable to only those engines/ generators complied with EPA (Environmental Protection Agency) and CARB (California Air Resources Board) emission regulations in the U.S.A.

**Notice :** To the engines/generators exported to and used in the countries other than the U.S.A., warranty service shall be performed by the distributor in each country in accordance with the standard Robin engine/generator warranty policy as applicable.

**SUPPLEMENTAL INFORMATION  
TO THE OWNER'S MANUAL FOR 2005 AND LATER  
EPA CERTIFIED  
NONROAD COMPRESSION IGNITION ENGINES.**

**EPA EMISSION CONTROL SUPPLEMENTAL  
WARRANTY STATEMENT.**

## **MAINTENANCE AND WARRANTY.**

### **SUPPLEMENTAL INFORMATION TO THE OWNERS MANUAL FOR 2005 AND LATER EPA CERTIFIED NONROAD COMPRESSION IGNITION ENGINES.**

The following supplemental information is furnished for EPA Nonroad Compression Ignition Engines which are certified according to 40 CFR Part 89.

This information contains the following specific items:

- EPA-related engine parts and engine operating conditions
- Maintenance instructions for EPA-related engine parts
- Emission control system and adjustments
- Warranty statement

### **ENGINE PARTS AND / OR EQUIPMENT RELATED TO EPA EXHAUST EMISSION REGULATIONS.**

Parts which are mandatory for engine operation.

The following parts as manufactured according to HATZ specifications are mandatory for engine operation which meets EPA exhaust emission regulations.

- Fuel injection pump
- Injection nozzle
- Bimetallic strip
- Crankcase breather valve assembly
- Air cleaner housing
- Oil filler cap
- Intake and exhaust gaskets at head interfaces

Only parts manufactured by Hatz and which have passed the Hatz Quality Assurance Program are assured of meeting EPA exhaust emission regulations.

### **UNUSUAL OPERATING CONDITIONS.**

The engine must not be operated at a load factor less than 25 % for an extended period as such operation will cause the fuel injector to foul. If such a condition occurs, you should contact the nearest HATZ authorized Service Center for necessary repairs.

The engine is designed and adjusted to operate most efficiently at the following conditions:

- Air temperature of 25° C ( 77° F)
- Atmospheric pressure of 100 kPa (14.5 psi)
- Relative humidity of 30 %

Operation of the engine at conditions other than above will affect performance and exhaust emissions. Normally the equipment manufacturer takes this into account during the design of the machine and your equipment will perform within specifications over a wide range of climatic conditions. However if you must operate your equipment under very unusual climatic conditions, please contact your nearest Hatz distributor for advice.



## **MAINTENANCE SCHEDULE-EPA-RELATED PARTS**

The following minimum intervals are being adopted for adjustment, cleaning, repair, or replacement of following components:

At 1,500 hours, and 1,500-hours intervals thereafter:

- Fuel injector tips (cleaning only)

At 3,000 hours, and 3,000-hours intervals thereafter:

- Fuel injector

The exhaust quality of the engines can be influenced by the execution (the quality of execution) of above described maintenance work.

Therefore, the maintenance work has to be carried out by a qualified workshop.

Hatz authorised workshops, for example, are qualified workshops.

Hatz Diesel of America will give you respective addresses, if required.

## **EMISSION CONTROL SYSTEM AND ADJUSTMENTS.**

The emission control system for this engine is EM (Engine Modification).

No adjustments are needed or possible.

## **EPA EMISSION CONTROL WARRANTY STATEMENT**

### **YOUR WARRANTY RIGHTS AND OBLIGATIONS.**

Motorenfabrik Hatz GmbH & Co. KG warrants the emission control system on your engine for the periods of time listed below provided there has been no abuse, neglect or improper maintenance of your engine.

Your emission control system includes:

- Fuel injection pump
- Injection nozzle
- Bimetallic strip
- Crankcase breather valve assembly
- Air cleaner housing
- Oil filler cap
- Intake and exhaust gaskets at head interfaces

Where a warrantable condition exists, Motorenfabrik Hatz will repair your engine at no cost to you including diagnosis, parts and labor.

**MANUFACTURERS WARRANTY COVERAGE:**

The 2005 and later EPA certified nonroad compression ignition engines are warranted for 1500 hours of operation or two years of use, whichever first occurs.

If any emission related part on your engine is defective, the part will be repaired or replaced by Motorenfabrik Hatz.

**OWNERS WARRANTY RESPONSIBILITIES:**

- As the engine owner, you are responsible for the performance of the required maintenance listed in your owner's manual. Motorenfabrik Hatz recommends that you retain all receipts covering maintenance on your engine, but Motorenfabrik Hatz cannot deny warranty solely for the lack of receipts or for your failure to ensure the performance of all scheduled maintenance.
- As the engine owner, you should be aware, however, that Motorenfabrik Hatz may deny you warranty coverage if your engine or a part has failed due to abuse, neglect, improper maintenance or unapproved modifications.
- You are responsible for presenting your engine to a Motorenfabrik Hatz authorized service center as soon as a problem exists. The warranty repairs should be completed in a reasonable amount of time, not to exceed 30 days.

If you have any questions regarding your warranty rights and responsibilities, you should contact HATZ DIESEL OF AMERICA, Inc. at (262) 544-0254.

**HATZ DIESEL SUPPLEMENTAL WARRANTY FOR 2005 AND LATER EPA CERTIFIED ENGINES.****PARTS WITH SUPPLEMENTAL LIMITED WARRANTY.**

The following limited warranty is supplemental to the standard HATZ DIESEL LIMITED ENGINE WARRANTY and covers 2005 and later EPA certified engines and applies to the following exhaust emission-related components:

- Fuel injection pump
- Injection nozzle
- Bimetallic strip
- Crankcase breather valve assembly
- Air cleaner housing
- Oil filler cap
- Intake and exhaust gaskets at head interfaces

**SUPPLEMENTAL LIMITED WARRANTY.**

Hatz Diesel of America, Inc. hereinafter referred to as "HATZ" warrants each of the above-listed parts when installed in a new engine sold by Hatz to be free from defects in material and workmanship under normal use and service, only under the named warranty coverage conditions, after the date of delivery to the original retail purchaser and Hatz will at their option, repair or replace at Hatz's sales headquarters, or at a point designated by Hatz, any part or parts which shall appear to the satisfaction of Hatz upon inspection at such point, to have been defective in material or workmanship.

- Any warranted part which is scheduled for replacement as required maintenance is warranted for the period of time up to the first scheduled replacement point for that part.
- Any replacement part which is equivalent in performance and durability may be used in non-warranty maintenance or repairs and will not reduce the overall engine warranty obligations of Hatz. However, Hatz is not responsible for failure of such replacement parts or failure of any other parts directly caused by failure of such replacement parts.
- This warranty does not obligate Hatz to bear any transportation charges in connection with the repair or replacement of defective parts. This warranty is transferrable to subsequent owners, only under the named warranty coverage conditions.
- In order to obtain service under this warranty, the retail purchaser should contact Hatz Diesel of America, Inc. at (262) 544-0254 for information and the nearest service center.

The retail purchaser will not be charged for diagnostic labor which leads to the determination that a warranted part is defective, nor for the repair or replacement of warranted parts if the work is performed at an authorized Hatz service center. If other engine components are damaged due to a failure of the above-listed warranted parts still under warranty, these other engine components will also be repaired or replaced at no charge.

- This warranty shall not apply to any engine which shall have been installed or operated in a manner not recommended by Hatz, nor to any engine which shall have been repaired, altered, neglected, or used in any way which, in the opinion of Hatz, adversely affects its performance, nor to any engine in which parts not authorized by Hatz have been used, which parts or the use of which have damaged or caused defects in or otherwise adversely affected the engine or its performance, nor to normal maintenance service or replacement of normal service items.

Hatz reserves the right to modify, alter, and improve any engine or parts without incurring any obligation to replace any engine or parts previously sold with such modified, altered, or improved engine or parts.

**SUPPLEMENTAL INFORMATION  
TO THE OWNER'S MANUAL  
FOR 2005 AND LATER  
CALIFORNIA REGULATIONS FOR  
OFF-ROAD  
COMPRESSION-IGNITION ENGINES**

**CALIFORNIA EMISSION CONTROL  
WARRANTY STATEMENT**

## **MAINTENANCE AND WARRANTY.**

### **SUPPLEMENTAL INFORMATION TO THE OWNER'S MANUAL FOR 2005 AND LATER CALIFORNIA REGULATIONS FOR OFF-ROAD COMPRESSION-IGNITION ENGINES.**

The following supplemental information is furnished for California Off-Road Compression-Ignition Engines.

This information contains the following specific items:

- CARB-related engine parts and engine operating conditions
- Maintenance instructions for CARB-related engine parts
- Emission control system and adjustments
- Warranty statement

### **ENGINE PARTS AND / OR EQUIPMENT RELATED TO CARB EXHAUST EMISSION REGULATIONS.**

Parts which are mandatory for engine operation.

The following parts as manufactured according to HATZ specifications are mandatory for engine operation which meets CARB exhaust emission regulations.

- Fuel injector
- Fuel injection pump
- Bimetallic Strip
- Intake manifold
- Exhaust manifold
- Crankcase breather valve
- Oil filler Cap
- Intake and exhaust gaskets at head interfaces

Only parts manufactured by Hatz and which have passed the Hatz Quality Assurance Program are assured of meeting CARB exhaust emission regulations.

### **UNUSUAL OPERATING CONDITIONS.**

The engine must not be operated at a load factor less than 25 % for an extended period as such operation will cause the fuel injector to foul. If such a condition occurs, you should contact the nearest HATZ authorized Service Center for necessary repairs.

The engine is designed and adjusted to operate most efficiently at the following conditions:

- Air temperature of 25°C ( 77°F)
- Atmospheric pressure of 100 kPa (14.5 psi)
- Relative humidity of 30 %

Operation of the engine at conditions other than above will affect performance and exhaust emissions. Normally the equipment manufacturer takes this into account during the design of the machine and your equipment will perform within specifications over a wide range of climatic conditions. However if you must operate your equipment under very unusual climatic conditions, please contact your nearest Hatz distributor for advice.

## **MAINTENANCE SCHEDULE-CARB-RELATED PARTS.**

The following minimum intervals are being adopted for adjustment, cleaning, repair, or replacement of following components:

At 1,500 hours, and 1,500 hours intervals thereafter:

- Fuel injector tips (cleaning only)

At 3,000 hours, and 3000 hours intervals thereafter:

- Fuel Injectors

The exhaust quality of engines can be influenced by the execution (the quality of execution) of above described maintenance work.

Therefore, the maintenance work has to be carried out by a qualified workshop.

Hatz authorised workshops, for example, are qualified workshops.

Hatz Diesel of America will give you respective addresses, if required.

## **EMISSION CONTROL SYSTEM AND ADJUSTMENTS.**

The emission control system for this engine is EM (Engine Modification).

No adjustments are needed or possible.

## **CALIFORNIA EMISSION CONTROL WARRANTY STATEMENT.**

### **YOUR WARRANTY RIGHTS AND OBLIGATIONS.**

The California Air Resources Board and Motorenfabrik Hatz GmbH & Co. KG are pleased to explain the emission control system warranty on your 2005 and later off-road compression-ignition engine. In California, new off-road compression-ignition engines must be designed, built, and equipped to meet the State's stringent anti-smog standards. Motorenfabrik Hatz GmbH & Co. KG must warrant the emission control system on your engine for the periods of time listed below provided there has been no abuse, neglect or improper maintenance of your engine.

Your emission control system may include parts such as the fuel-injection system and the air induction system. Also included may be hoses, belts, connectors and other emission-related assemblies.

Where a warrantable condition exists, Motorenfabrik Hatz will repair your small off-road engine at no cost to you including diagnosis, parts and labor.

### **MANUFACTURER'S WARRANTY COVERAGE.**

The 2005 and later off-road compression-ignition engine is warranted for 1500 hours of operation or two years of use, whichever first occurs. If any emission-related part on your engine is defective, the part will be repaired or replaced by Motorenfabrik Hatz GmbH & Co. KG.

**OWNER'S WARRANTY RESPONSIBILITIES.**

- As the off-road compression-ignition engine owner, you are responsible for the performance of the required maintenance listed in your owner's manual.  
Motorenfabrik Hatz GmbH & Co. KG recommends that you retain all receipts covering maintenance on your off-road compression-ignition engine, but Motorenfabrik Hatz GmbH & Co. KG cannot deny warranty solely for the lack of receipts or for your failure to ensure the performance of all scheduled maintenance.
- As the off-road compression-ignition engine owner, you should however be aware, that Motorenfabrik Hatz GmbH & Co. KG may deny you warranty coverage if your off-road compression-ignition engine or a part has failed due to abuse, neglect, improper maintenance or unapproved modifications.
- Your engine is designed to operate on diesel fuel only. Use of any other fuel may result in your engine no longer operating in compliance with California's emission requirements.
- You are responsible for initiating the warranty process. The ARB suggests that you present your off-road compression-ignition engine to a Motorenfabrik Hatz authorised dealer as soon as a problem exists. The warranty repairs should be completed by the dealer as expeditiously as possible.

If you have any questions regarding your warranty rights and responsibilities, you should contact HATZ DIESEL OF AMERICA, Inc. at (262)-544-0254.

**HATZ DIESEL SUPPLEMENTAL WARRANTY FOR 2005 AND LATER CALIFORNIA CERTIFIED OFF-ROAD COMPRESSION-IGNITION ENGINES.****PARTS WITH SUPPLEMENTAL LIMITED WARRANTY.**

The following limited warranty is supplemental to the standard HATZ DIESEL LIMITED ENGINE WARRANTY and covers 2005 and later California certified off-road compression-ignition engines and applies to the following exhaust emission-related components:

- Fuel injector
- Fuel injection pump
- Bimetallic Strip
- Intake manifold
- Exhaust manifold
- Crankcase breather valve
- Oil filler Cap
- Intake and exhaust gaskets at head interfaces

**SUPPLEMENTAL LIMITED WARRANTY.**

Hatz Diesel of America, Inc. hereinafter referred to as "HATZ" warrants each of the above-listed parts when installed in a new engine sold by Hatz to be free from defects in material and workmanship under normal use and service, for a period of twenty-four (24) months after the date of delivery to the original retail purchaser and Hatz will at their option, repair or replace at Hatz's sales headquarters, or at a point designated by Hatz, any part or parts which shall appear to the satisfaction of Hatz upon inspection at such point, to have been defective in material or workmanship.

- Any warranted part which is scheduled for replacement as required maintenance is warranted for the period of time up to the first scheduled replacement point for that part.
- Any replacement part which is equivalent in performance and durability may be used in non-warranty maintenance or repairs and will not reduce the overall engine warranty obligations of Hatz. However, Hatz is not responsible for failure of such replacement parts or failure of any other parts directly caused by failure of such replacement parts.
- This warranty does not obligate Hatz to bear any transportation charges in connection with the repair or replacement of defective parts. This warranty is transferrable to subsequent owners within the original twenty-four (24) months time period.
- In order to obtain service under this warranty, the retail purchaser should contact Hatz Diesel of America, Inc. at (262)-544-0254 for information and the nearest service center. The retail purchaser will not be charged for diagnostic labor which leads to the determination that a warranted part is defective, nor for the repair or replacement of warranted parts if the work is performed at an authorized Hatz service center. If other engine components are damaged due to a failure of the above-listed warranted parts still under warranty, these other engine components will also be repaired or replaced at no charge.
- This warranty shall not apply to any engine which shall have been installed or operated in a manner not recommended by Hatz, nor to any engine which shall have been repaired, altered, neglected, or used in any way which, in the opinion of Hatz, adversely affects its performance, nor to any engine in which parts not authorized by Hatz have been used, which parts or the use of which have damaged or caused defects in or otherwise adversely affected the engine or its performance, nor to normal maintenance service or replacement of normal service items.

Hatz reserves the right to modify, alter, and improve any engine or parts without incurring any obligation to replace any engine or parts previously sold with such modified, altered, or improved engine or parts.



# FOREWORD

Thank you very much for purchasing a **ROBIN GENERATOR**.

This manual covers operation and maintenance of the **ROBIN GENERATOR**.

This **ROBIN GENERATOR** can be used for general electrical equipments, appliances, lamps, tools as an AC power source. With regards to DC application, the terminals are used only for charging 12 volt battery. Never use this generator for any other purposes.

Please take a moment to familiarize yourself with the proper operation and maintenance procedures in order to maximize the safe and efficient use of this product.

Keep this owner's manual at hand, so that you can refer to it at any time.

Due to constant efforts to improve our products, certain procedures and specifications are subject to change without notice.

When ordering spare parts, always give us the **MODEL, PRODUCTION NUMBER (PROD No.)** and **SERIAL NUMBER (SER No.)** of your Product.

Please fill in the following blanks after checking the production number on your product.  
(Location of label is different depending on the product model.)

PROD NO.									

SER NO.				

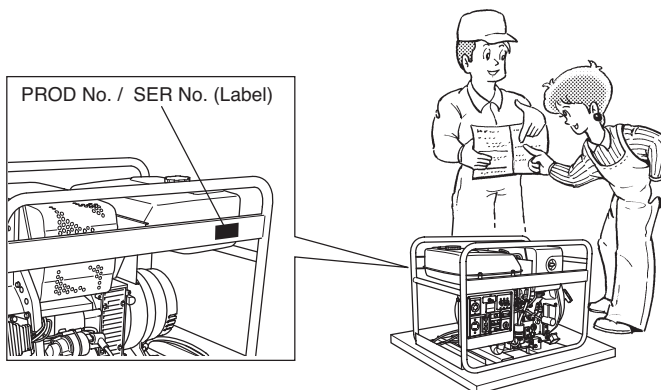

# CONTENTS

SAFETY PRECAUTIONS .....	2
COMPONENTS .....	5
PRE-OPERATION CHECKS .....	5
OPERATING PROCEDURES .....	8
WATTAGE INFORMATION .....	13
MAINTENANCE .....	15
PERIODIC OPERATION AND INSPECTION .....	20
TRANSPORTING .....	20
PREPARATION FOR STORAGE .....	21
TROUBLESHOOTING .....	21
SPECIFICATIONS .....	24
WIRING DIAGRAM .....	25

**NOTE** Please refer to the illustrations on the back page of the front cover or back cover for Fig. ① to ⑤ indicated in the sentence.

# SAFETY PRECAUTIONS

Please make sure you review each precaution carefully.  
Pay special attention to statement preceded by the following words.

**⚠ DANGER** “DANGER” indicates a possibility of death or serious injury if instructions are not followed.

**⚠ WARNING** “WARNING” indicates a strong possibility of severe personal injury or loss of life if instructions are not followed.

**⚠ CAUTION** “CAUTION” indicates a possibility of personal injury or equipment damage if instructions are not followed.

## ⚠ WARNING

Do not operate the generator near gasoline or gaseous fuel because of the potential danger of explosion or fire.

Do not fill the fuel tank with fuel while the engine is running. Do not smoke or use open flame near the fuel tank. Be careful not to spill fuel during refueling. If fuel is spilt, wipe it off and let dry before starting the engine.



## ⚠ WARNING

Do not place in flammables near the generator.

Be careful not to place fuel, matches, gunpowder, oily cloths, straw, trash, or any other in flammables near the generator.

## ⚠ WARNING

Do not operate the generator inside a room, cave, tunnel, or other insufficiently ventilated area.

Always operate it in a well-ventilated area, otherwise the engine may become overheated, and the poisonous carbon monoxide gas, an odorless, colorless, poison gas, contained in the exhaust gas will endanger human lives. Operate generator only outdoors and far from open windows, doors, ventilation intakes and other openings.

Keep the generator at least 1 meter (3 feet) away, including overhead, from any structure or building use.

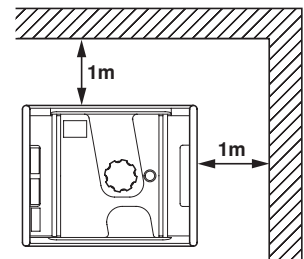

## ⚠ WARNING

Do not enclose the generator nor cover it with a box.

The generator has a built-in forced air cooling system, and may become overheated if it is enclosed.

If generator has been covered to protect it from the weather during non use, be sure to remove it and keep it well away from the area during generator use.

## ⚠ WARNING

Operate the generator on a level surface.

It is not necessary to prepare a special foundation for the generator.

However, the generator will vibrate on an irregular surface, so choose a level place without surface irregularities.

If the generator is tilted or moved during operation, fuel may spill and / or the generator may tip over, causing a hazardous situation.

Proper lubrication cannot be expected if the generator is operated on a steep incline or slope. In such a case, piston seizure may occur even if the oil is above the upper level.

## ⚠ WARNING

Pay attention to the wiring or extension cords from the generator to the connected device.

If the wire is under the generator or in contact with a vibrating part, it may break and possibly cause a fire, generator burnout, or electric shock hazard.

Replace damaged or worn cords immediately.



**⚠ WARNING**

Do not operate in rain, in wet or damp conditions, or with wet hands.  
The operator may suffer severe electric shock if the generator is wet due to rain or snow.

**⚠ WARNING**

If wet, wipe and dry it well before starting. Do not pour water directly over the generator, nor wash it with water.

**⚠ WARNING**

Be extremely careful that all necessary electrical grounding procedures are followed during each and every use. Failure to do so can be fatal.

**⚠ WARNING**

Do not contact the generator to a commercial power line. Connection to a commercial power line may short circuit the generator and ruin it or cause electric shock hazard. Use the transfer switch for connecting to domestic circuit.

**⚠ WARNING**

No smoking while handling the battery. The battery emits flammable hydrogen gas, which can explode if exposed to electric arcing or open flame.  
Keep the area well-ventilated and keep open flames/sparks away when handling the battery.

**⚠ WARNING**

Engine becomes extremely hot during and for some time after operation. Keep combustible materials well away from generator area.  
Be very careful not to touch any parts of the hot engine especially the muffler area or serious burns may result.

**⚠ WARNING**

Keep children and all bystanders at a safe distance from work areas.

**⚠ WARNING**

It is absolutely essential that you know the safe and proper use of the power tool or appliance that you intend to use. All operators must read, understand and follow the tool/appliance owners manual. Tool and appliance applications and limitations must be understood. Follow all directions given on labels and warnings. Keep all instruction manuals and literature in a safe place for future reference.

**⚠ WARNING**

Use only "LISTED" extension cords.  
When a tool or appliance is used outdoors, use only extension cords marked "For Outdoor Use". Extension cords, when not in use should be stored in a dry and well ventilated area.

**⚠ WARNING**

Always switch off generator's AC circuit breaker and disconnect tools or appliances when not in use, before servicing, adjusting, or installing accessories and attachments.

**⚠ CAUTION**

Make sure the engine is stopped before starting any maintenance, servicing or repair.  
Make sure maintenance and repair of the generator set are performed by properly trained personnel only.

## Symbols and Meanings

In accordance with the European requirements (EEC Directives), the specified symbols as shown in the following table are used for the products and this instruction manual.

	<i>Read the operator's instruction manual.</i>		<i>Fire, open light and smoking prohibited.</i>
	<i>Stay clear of the hot surface.</i>		<i>Caution, risk of electric shock.</i>
	<i>Exhaust gas is poisonous. Do not operate in an unventilated room.</i>		<i>Do not connect the generator to the commercial power lines.</i>
	<i>Stop the engine before refueling.</i>		<i>HOT, avoid touching the hot area.</i>

	<i>ON (power and Engine)</i>		<i>IN-position of a bistable push control</i>		<i>Engine start (Electric start)</i>
	<i>OFF (power and Engine)</i>		<i>Protective earth (ground)</i>		<i>Engine stop</i>
	<i>Alternating current</i>		<i>Fuse</i>		<i>Diesel fuel</i>
	<i>Direct current</i>		<i>Engine oil</i>		<i>Fast</i>
	<i>Plus ; positive polarity</i>		<i>Add oil</i>		<i>Slow</i>
	<i>Minus ; negative polarity</i>		<i>Battery charging condition</i>		<i>Fuel start / Open</i>
	<i>OUT-position of a bistable push control</i>		<i>Choke ; cold starting aid</i>		<i>Fuel stop / Close</i>

$P_r$	<i>Rated power (kW)</i>	$COP$	<i>Continuous power</i>	$\cos\phi_r$	<i>Rated power factor</i>
$f_r$	<i>Rated frequency (Hz)</i>	$U_r$	<i>Rated voltage (V)</i>	$I_r$	<i>Rated current (A)</i>
$H_{max}$	<i>Maximum site altitude above sea-level (m)</i>	$T_{max}$	<i>Maximum ambient temperature (°C)</i>	m	<i>Mass (kg)</i>

## COMPONENTS

(See Fig. ①)

### NOTE

Please refer to the illustrations on the back page of the front cover or back cover for Fig. ① to ⑤ indicated in the sentence.

- ① CONTROL PANEL
- ② FUEL TANK
- ③ FUEL GAUGE
- ④ TANK CAP
- ⑤ AIR CLEANER
- ⑥ FUEL COCK
- ⑦ OIL GAUGE (OIL FILLER)
- ⑧ SPEED ADJUSTER
- ⑨ OIL FILTER
- ⑩ OIL DRAIN PLUG
- ⑪ FUEL FILTER
- ⑫ RECOIL STARTER
- ⑬ RECOIL STARTER HANDLE
- ⑭ MUFFLER
- ⑮ ELECTRIC STARTER

### CONTROL PANEL

- a AC RECEPTACLES (20A)
- b VOLTMETER
- c FULL POWER SWITCH
- d DC FUSE
- e AC CIRCUIT BREAKER
- f HOUR METER
- g KEY SWITCH
- h GROUND TERMINAL
- i DC TERMINALS
- ① AC RECEPTACLES (30A)

## PRE-OPERATION CHECKS

(See Fig. ②)

### 1. CHECK ENGINE OIL

(See Fig. ②-① thru ③)

#### Oil quality

Qualified are all trademark oils which fulfil at least one of the following specifications:

**ACEA – B2 / E2** or more significant

**API – CD / CE / CF / CF-4 / CG-4** or more significant.

If engine oil of a poorer quality is used, reduce oil change intervals to 150 hours of operation.

#### Oil viscosity (See Fig. ②-①)

Select the viscosity class according to the ambient temperature for cold starts.

When adding oil or checking the oil level, the engine must be horizontal.

- Remove oil filler screw and add engine oil.

(See Fig. ②-②)

Oil capacity (Upper level) :	(L)
RGD3300H .....	1.1
RGD5000H .....	1.5

- To check the oil level, remove the dipstick, clean it - then screw it back in and finally remove it again.

Check the oil level on the dipstick and, if necessary, top up to the **max.** level.

(See Fig. ②-③)

### 2. CHECK FUEL

#### ⚠ WARNING

**Stop the engine before refilling the fuel tank. Never refuel near a naked flame or sparks which could start a fire.**

**Don't smoke.**

**Use only pure fuel and clean filling equipment.**

**Take care not to spill fuel.**

All diesel fuels which satisfy the following specifications are suitable:

- EN 590 or
- BS 2869 A1 / A2 or
- ASTM D 975 - 1D / 2D

- Remove fuel tank cap.
- Before the first start or if the fuel tank has been run dry, completely fill the fuel tank with diesel. The bleeding of the fuel system is automatically.

<b>Fuel tank capacity :</b>	<b>(L)</b>
RGD3300H .....	12.0
RGD5000H .....	12.0

**NOTE**

If a double fuel filter system is provided , wait for a short time after replenishing fuel (approx. 1 to 2 minutes) for automatic bleeding to be completed.

- Close and fix fuel tank cap.
- At temperatures below 0 °C, winter-grade fuel should be used or paraffin added to the fuel well in advance.

Lowest ambient temperature when starting, in °C	Paraffin content for:	
	Summer fuel	Winter fuel
0 up to -10	20 %	—
-10 up to -15	30 %	—
-15 up to -20	50 %	20 %
-20 up to -30	—	50 %

- Wipe off any spilled fuel before starting the engine.(See Fig. ②-④)

**⚠ WARNING**

**Make sure you review each warning in order to prevent fire hazard.**

- Do not refill tank while engine is running or hot.
- Close fuel cock before refueling with fuel.
- Be careful not to admit dust, dirt, water or other foreign objects into fuel.
- Wipe off spilt fuel thoroughly before starting engine.
- Keep open flames away.

**3. CHECKING COMPONENT PARTS**

Check following items before starting engine:

- Fuel leakage from fuel hose, etc.
- Bolts and nuts for looseness.
- Components for damage or breakage.
- Generator not resting on or against any adjacent wiring.

**4. CHECK GENERATOR SURROUNDINGS.**

**⚠ WARNING**

**Make sure you review each warning in order to prevent fire hazard.**

- Keep area clear of in flammables or other hazardous materials.
- Keep generator at least 3 feet (1 meter) away from buildings or other structures.
- Only operate generator in a dry, well ventilated area.
- Keep exhaust pipe clear of foreign objects.
- Keep generator away from open flame. No smoking!
- Keep generator on a stable and level surface.
- Do not block generator air vents with paper or other material.

**5. GROUNDING THE GENERATOR**

- To ground the generator to the earth, connect the grounding lug of the generator to the grounding spike driven into the earth or to the conductor which has been already grounded to the earth. (See Fig. ②-⑤)

**① GROUNDING SPIKE**

- If such grounding conductor or grounding electrode is unavailable, connect the grounding lug of the generator to the grounding terminal of the using electric tool or appliance. (See Fig. ②-⑥)

**① GROUND TERMINAL**

## 6. BATTERY INSTALLATION

- Attach terminals to a lead-acid battery already charged. Mount the battery onto the position as specified below, with its terminals facing inward.
- Insert each long bolt through the specified hole, its tip pointing outward.
- Put the supporting arm on the long bolts and tighten with the butterfly nuts. (Push the lead-acid battery all the way inward.)
- Arrange the wiring so that it won't be damaged by possible vibration caused by the engine.
- Only after checking that the engine's starter key is in the "OFF" position, securely connect the red cable, to the positive (+) terminal. And then connect the other cable to the negative (-) terminal.

**Red cable : to the (+) terminal**

**Black cable : to the (-) terminal**

### Recommended Battery (Lead-acid type)

Capacity	: 12V-36A·h or larger
Size (Max)	: 10.2 x 5.1 x 8.1 [in.]
[L x W x H]	: 260 x 130 x 205 [mm]

### Make and Model

Interstate	: SP-40 model
------------	---------------

### ⚠ CAUTION

Should the connection be made in incorrect manner, the engine will be broken.

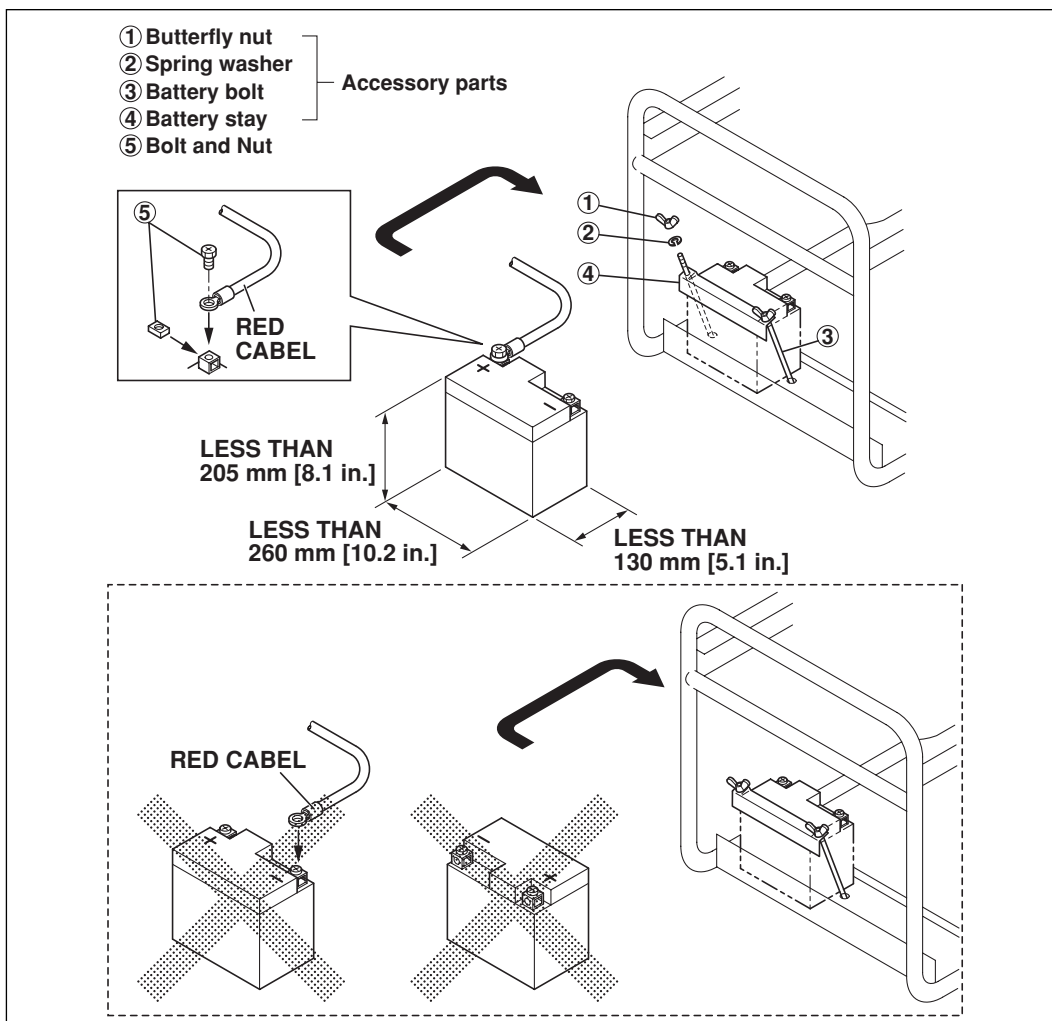

# OPERATING PROCEDURES

(See Fig. ③, ④)

## 1. STARTING THE GENERATOR

### ⚠ WARNING

Do not run the engine in closed or badly ventilated rooms - danger of poisoning ! Before starting the engine, ensure that no-one is in the danger area close to the engine or equipment, and that all protective guards are fitted.

### ⚠ CAUTION

Check the oil level before each operations as outlined on page 5.

#### (a) Before starting (See Fig. ③-① thru ⑤)

- Make sure the appliance is disconnected.
- Turn the fuel cock to **OPEN** position.  
(See Fig. ③-①)
  - ① OPEN      ② CLOSE
- Turn the AC circuit breaker to the **OFF** position.  
(See Fig. ③-②)
  - ① ON      ② OFF
- First of all set the speed adjuster to the **STOP** position (See Fig. ③-③), then move it to the starting position.
  - ① SPEED ADJUSTER
  - ② STOP position
  - ③ 1/2
  - ④ START position
- Set speed adjustment lever either to 1/2 **START** or max. **START** position, as desired or necessary. (See Fig. ③-④)  
Starting at a lower speed will help to prevent exhaust smoke.
- Move speed adjuster to the "**START/RUN**" position. (See Fig. ③-⑤)

Now, the engine is ready for starting.

#### (b) Starting (See Fig. ③-⑥ thru ⑨)

### ⚠ CAUTION

- Do not connect defective appliances including lines and plugs.
- Be sure appliances are not connected to generator when starting up. Starting the generator with an appliance connected could result in damage to the generator and/or appliance and in personal injury.

- Insert the key, and depress and turn it to position **RUN** (See Fig. ③-⑥)
  - ① STOP      ② RUN      ③ START
- Turn the key to position **START**.  
(See Fig. ③-⑦)
- Release the key as soon as the engine runs. The starting key must spring back to position **RUN** and remain there during engine operation.
- The battery charge and oil pressure lights should extinguish directly after the engine starts. The display lamp ① lights up to show that the engine is running. (See Fig. ③-⑧)
  - ① Engine Operation Indicator Light
  - ② Battery Charge Indicator Light
  - ③ Oil Pressure Warning Light
  - ④ Engine Temperature Warning Light
- Prior to starting up again, the key has to be returned to position **STOP**. When the engine is running the starter repeat lock in the ignition switch will prevent the starter from engaging and suffering damage.  
(See Fig. ③-⑨)

### ⚠ CAUTION

- Do not run the starting motor over 5 seconds continuously. If the engine fails to start, return the key to the **RUN** position and wait about 10 seconds then start again.
- When starting the engine by recoil starter, set the key switch at the **RUN** position and pull the starter handle.



**(c) Emergency start (See Fig. 3-10)**

If the **shut-off valve** is blocking the fuel supply as a result of an **electrical fault** and the **engine therefore cannot be started**, an emergency start can be attempted.

Proceed as follows for this:

- For emergency starting, turn the lever at fuel shut-off solenoid ① anti-clockwise by at least 90° using suitable pliers. The lead seal wire will break off.
- As soon as the emergency start lever is in the starting position, the electric starter or recoil starter can be used; (See Fig. 3-10).  
The oil level must always be checked before an emergency start, as insufficient oil pressure can lead to complete damage of the engine within a very short time.

**⚠ WARNING**

**After this, the engine can only be stopped with the starting key in the emergency operating mode if the emergency starting lever is first turned back clockwise to the stop position.**

Immediately after a period of emergency running, ascertain the cause of the fault and have it rectified; page 21 "**TROUBLESHOOTING**".

Have the emergency-starting lever sealed once again by a **ROBIN service point**.

When the automatic electrical shutdown system is used, the emergency start described above means that liability for risks must be accepted by the operator (**Engine manufacture assumes no liability**).

In case of difficulty contact the nearest **ROBIN service point**.

**(d) Starting with recoil starter  
[down to - 6 °C] (See Fig. 3-11, 12)**

Recoil starter can be utilized for emergency starting purpose. Before recoil starter operation, please read the "**(c) Emergency start**"

**⚠ CAUTION**

**Follow the starting procedures described below, without fail.**

- **In case the starting cable is pulled in short length, engine does not start due to no cranking; the piston does not reached to the TDC.**
- **In case of poor pulling force at low speed, engine does not start due to no activation of centrifugal decompression mechanism.**

- Pull the starting cable out by the handle until you feel a slight resistance. (See Fig. 3-11)
- Let the cable run back; in this way the entire length of the starting cable can be used to start the engine.
- Devices which are not securely fastened should be restrained with the foot.
- Grip the handle with both hands.
- Commence pulling the starting cable vigorously and at an increasing speed (do not jerk it violently) until the engine starts.  
(See Fig. 3-12)

**⚠ CAUTION**

**If after several attempts of starting the exhaust begins to emit white smoke, move the speed adjustment lever to the STOP position and pull the starting cable out slowly 5 times.  
Repeat the "(a) Before starting"**

## 2. USING ELECTRIC POWER

- Check the voltmeter for proper voltage. (approx.120V).

### NOTE

If no generating condition is found out, please consult nearest ROBIN dealer.

### ⚠ WARNING

- Make sure that the appliance is switched OFF before connecting it to the generator.
- Do not move the generator while it is running.
- Be sure to ground the generator if the connected appliance is grounded. Failure to ground unit may lead to electrical shock.

### (1) AC APPLICATION (See Fig. 4-①,②)

(a) Check the voltmeter for proper voltage. (approx.120V).

- This generator is thoroughly tested and adjusted in the factory.



If the generator does not produce the specified voltage, consult your nearest Robin dealer or service shop.

(b) Turn off the switch(es) of the electrical appliance(s) before connecting to the generator.

(c) Insert the plug(s) of the electrical appliance(s) into the receptacle. (See Fig. 4-①)

- Check the amperage of the receptacles used referring to **TABLE 1**, and be sure not to take a current exceeding the specified amperage.
- Be sure that the total wattage of all appliances dose not exceed the rated output of the generator.

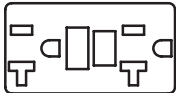
(d) Turn the AC circuit breaker to the position **ON**. (See Fig. 4-②)

Style	Ampere	Receptacle	AC plug	Description
	Up to 20A	NEMA 5-20R	NEMA 5-20P	GFCI (Ground Fault Circuit Interrupter) Receptacle, duplex
	Up to 30A	NEMA 5-30R	NEMA 5-30P	Locking Receptacle
	Up to 20A	NEMA L14-20R	NEMA L14-20P	Locking Receptacle

**TABLE 1**

### ⚠ WARNING

- To take power out from the **TWIST LOCK RECEPTACLE**, insert the plug into the receptacle, and turn it clockwise to the lock position. (See Fig. 4-③)
- Be sure to ground the generator if the connected electrical device is grounded.

**⚠ CAUTION**

**Do not put foreign objects into the plug receptacle.**

**NOTE**

When the AC circuit breaker turns off during operation, the generator is over loaded or the appliance is defective. Stop the generator immediately, check the appliance and / or generator for overloading, and have repaired as necessary by Robin dealer or service shop.

(e) Turn on the switch of the appliance.

**(2) DC APPLICATION (See Fig. 4-4)**

The DC terminal is used only for charging 12 volt batteries. It provides up to 12V-8.3A (100W) of maximum power.

- ❶ Positive terminal (RED)
- ❷ Negative terminal (BLACK)

**CONNECTION OF CABLE :**

- Connect positive terminal (red) on generator to positive (+) terminal on battery.
- Connect negative terminal (black) on generator to negative (-) terminal on battery.

**SAFETY PRECAUTIONS WHILE CHARGING**

- An explosive hydrogen gas is discharged through vent holes in the battery during the charging process. Do not allow spark or open flame around the generator or battery during the charging process.
- Electrolyte fluid can burn eyes and clothing. Be extremely careful to avoid contact. If injured, wash the affected area immediately with large quantities of water and consult a doctor for treatment.
- When charging a large capacity battery or totally discharged battery, excessive current may force the DC out. In such cases, use a battery charger to charge a large battery with AC output.

**FUSE REPLACEMENT (See Fig. 4-5)**

- If a fuse burns out, check for the cause of trouble, and make the necessary repairs before installing the new fuse.
  - ❶ FUSE
- Be sure to use the correct fuse. An incorrect fuse may cause damage to the generator.
- The fuse rating for DC output is 10A.

### 3. FULL POWER SWITCH

Select the voltage using the FULL POWER SWITCH in accordance with the electrical appliance.

Refer to **TABLE 2**.

#### **⚠ CAUTION**

**Change the FULL POWER SWITCH after turning the AC circuit breaker to "OFF".**

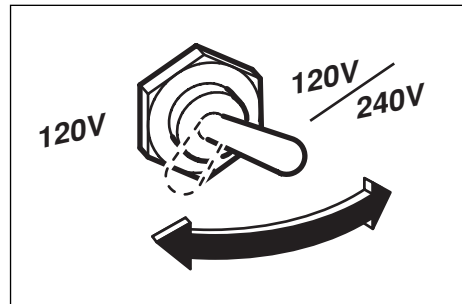

#### **NOTE**

Voltmeter always indicates the lower voltage whichever the FULL POWER SWITCH is set.

Switch position	Lower Voltage Receptacle	Higher Voltage Receptacle
120V	Activated full rated output	N.A
120/240V	Activated half of rated output	Activated full rated output

**TABLE 2**

### 4. STOPPING THE GENERATOR

- Turn off the power switch of the electric equipment and unplug the cord from receptacle of the generator.
- Allow the engine about 3 minutes to cool down at no load before stopping.
- Move the speed adjustment lever back to the STOP position.

The engine cuts out. (See Fig. 4-6)

- SPEED ADJUSTER
- STOP position

#### **⚠ CAUTION**

**Be sure to turn the key switch to STOP position after stopping.**

## WATTAGE INFORMATION

Some appliances need a "surge" of energy when starting.

This means that the amount of electrical power needed to start the appliance may exceed the amount needed to maintain its use.

Electrical appliances and tools normally come with a label indicating voltage, cycles / Hz, amperage (amps) and electrical power needed to run the appliance or tool.

Check with your nearest dealer or service center with questions regarding power surge of certain appliances or power tools.

- Electrical loads such as incandescent lamps and hot plates require the same wattage to start as is needed to maintain use.
- Loads such as fluorescent lamps require 1.2 to 2 times the indicated wattage during start-up.
- Loads for mercury lamps require 2 to 3 times the indicated wattage during start-up.
- Electrical motors require a large starting current. Power requirements depend on the type of motor and its use. Once enough "surge" is attained to start the motor, the appliance will require only 50% to 30% of the wattage to continue running.
- Most electrical tools require 1.2 to 3 times their wattage for running under load during use. For example, a 5000 watt generator can power a 1800 to 4000 watt electrical tool.
- Loads such as submersible pumps and air compressors require a very large force to start. They need 3 to 5 times the normal running wattage in order to start.  
For example, a 5000 watt generator would only be able to drive a 1000 to 1700 watt pump.

### NOTE

The following wattage chart is general guide only. Refer to your specific appliance for correct wattage.

To determine the total wattage required to run a particular electrical appliance or tool, multiply the voltage figure of the appliance/tool by the amperage (amps) figure of same. The voltage and amperage (amps) information can be found on a name plate which is normally attached to electrical appliances and tools.

Applications	Applicable Wattage (approx. W)	
	RGD3300H	RGD5000H
	60Hz	
Incandescent lamp, Heater	3000	4500
Fluorescent lamp, Electric tool	1500	3000
Mercury lamp	1200	2700
Pump, Compressor	600	1300

## VOLTAGE DROP IN ELECTRIC EXTENSION CORDS

When a long electric extension cord is used to connect an appliance or tool to the generator, a certain amount of voltage drop or loss occurs in the extension cord which reduces the effective voltage available for the appliance or tool.

The chart below has been prepared to illustrate the approximate voltage loss when an extension cord of 300 feet (approx. 100 meters) is used to connect an appliance or tool to the generator.

Nominal cross section	A.W.G.	Allowable current	No.of strands / strands dia.	Resistance	Current Amp.							Voltage drop
					1A	3A	5A	8A	10A	12A	15A	
mm <sup>2</sup>	No.	A	No./mm	Ω/100m	1A	3A	5A	8A	10A	12A	15A	
0.75	18	7	30/0.18	2.477	2.5V	8V	12.5V	—	—	—	—	
1.27	16	12	50/0.16	1.486	1.5V	5V	7.5V	12V	15V	18V	—	
2.0	14	17	37/0.26	0.952	1V	3V	5V	8V	10V	12V	15V	
3.5	12 to 10	23	45/0.32	0.517	—	1.5V	2.5V	4V	5V	6.5V	7.5V	
5.5	10 to 8	35	70/0.32	0.332	—	1V	2V	2.5V	3.5V	4V	5V	

# MAINTENANCE

## DAILY INSPECTION

Before running the generator, check the following service items:

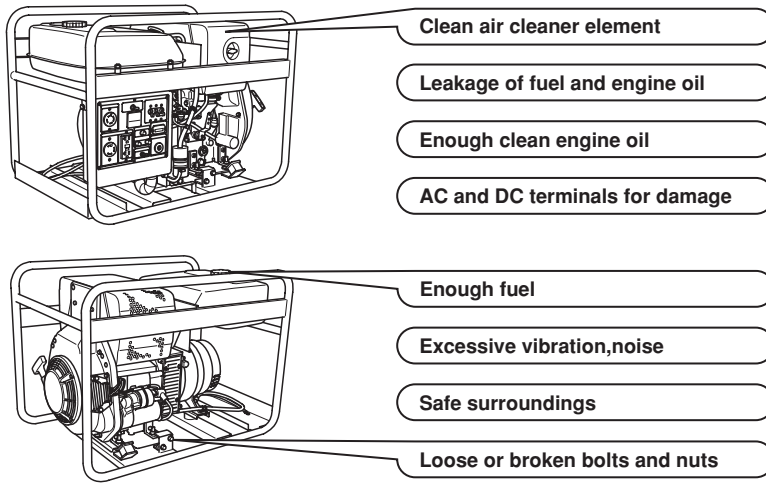





## PERIODIC MAINTENANCE

Periodic maintenance is vital to safe and efficient operation of your generator. Check the table below for periodic maintenance intervals.

### ⚠ WARNING

**Only carry out maintenance work with the engine switched off.**  
**Observe all relevant laws and regulations governing the handling and disposal of used oil, filters and cleaning agents.**  
**Protect the starting key against unauthorised use.**  
**On engines with an electric starter, disconnect the battery's negative terminal.**  
**When maintenance work has been completed, check that all tools have been removed from the engine and all protective guards fitted again.**  
**Before starting the engine, ensure that there are no persons in the danger area close to the engine or equipment.**

### Maintenance chart (ENGINE)

Maintenance interval	Maintenance work required
 Every 8 - 15 operating hours, or before each daily start-up	Check oil level. Check combustion and cooling air intake zone.
 Every 250 operating hours	Change engine oil. Check and adjust valve clearances. Clean cooling air area. Check screw connections. Clean mesh insert for exhaust.
 Every 500 operating hours	Change fuel filter element. Dry-type air cleaner maintenance.
 Every 1000 operating hours	Clean the oil filter.





**⚠ CAUTION**

Make sure the engine is stopped before starting any maintenance, servicing or repair.

**NOTE**

It is recommended to use ear protection when performing operation, maintenance and repair of the generator set.

**1. CHECK ENGINE OIL LEVEL**

(See Fig. ②-③)

To check the oil level, the engine must be standing level and be switched off.

- Remove any dirt from the oil dipstick area.
- Remove dipstick and clean it.
- To check the oil, screw the dipstick back in and then remove it again.
- Check the dipstick oil level and, if necessary, add oil to the **max.** mark, (See Fig. ②-③).

**2. CHECK COMBUSTION AND COOLING AIR INTAKE**

(See Fig. ⑤-①)

Heavy contamination is an indication that increased dust accumulation necessitates a correspondingly shorter maintenance interval,

- Check air intake points for severe blockage due to leaves, heavy dust accumulation etc., and if necessary clean them.  
(See Fig. ⑤-①)

**3. ENGINE OIL CHANGE**

(See Fig. ⑤-②)

The engine must be standing level and be switched off.

Only change the oil when the engine is warm.

**⚠ WARNING**

**Danger of scalding from hot oil !  
Trap the old oil and dispose of it in accordance with local legislation.**

- ① Drain plug
  - ② Washer
- Take out oil drain plug and allow the oil to drain out.
  - Clean the oil drain plug, fit a new washer, insert and tighten.  
**Tightening torque: 50 Nm.**
  - Add engine oil

**4. CHECK AND ADJUST VALVE CLEARANCES**

(See Fig. ⑤-③ thru ⑦)

Only carry out adjustments when the engine is cold (10 - 30 °C).

- Remove cover to air filter. (See Fig. ⑤-③)
- Remove noise insulating hood. (See Fig. ⑤-④)
- Remove any contamination adhering to the cover for the cylinder head.
- Remove screws ① (two screws on 1B20 and 1B30 engines, three screws on 1B40 engines) and take off the cylinder head cover with gasket ②. (See Fig. ⑤-⑤)
- Remove rubber cap from the inspection hole cover.
- Turn the engine over in the normal direction of rotation until the valves are in the overlap position (exhaust valve not yet closed, inlet valve starts to open).

- Turn the crankshaft through 360° in the normal direction of rotation and align exactly to the OT-marking. (See Fig. 5-6)
- Check valve clearances with feeler gauge 1. (See Fig. 5-7)
- If valve clearances require adjusting, slacken off screw 2 and turn hex nut 3 until feeler gauge 1 can be pulled through with just slight resistance when screw 2 is retightened.
- Fit cover for cylinder head and tighten evenly, always using a new gasket.
- Re-attach parts previously removed from engine.  
**Do not forget:** replace the rubber cap at the inspection hole cover.
- Carry out a brief test run, then check the cover for leaks.

## 5. COOLING AIR AREA

### ⚠ WARNING

**The engine must be switched off and cooled down before cleaning !**

- If severely contaminated, clean the cooling fins on the cylinder and cylinder head, and also the fan blades in the flywheel. If necessary, contact your local ROBIN service station.

## 6. CHECKING SCREW CONNECTIONS

- Check the tightness of all threaded connections and take up slack if necessary, provided that these can be reached during maintenance work.  
**Do not tighten the cylinder head bolts.**

## 7. EXHAUST MESH INSERT

(See Fig. 5-8 thru 10)

### ⚠ WARNING

**Exhaust system components will naturally be hot and must not be touched while the engine is running or until it has cooled down after being stopped.**

- Unscrew hex nut and remove the exhaust mesh insert. (See Fig. 5-8)
- Remove any deposits in the mesh insert by means of a wire brush.
- Check the exhaust mesh insert for cracks or damage and, if necessary replace with a new one.
- Screw on hexagon nut 1 by approx. 1 turn. (See Fig. 5-9)
- Insert exhaust screen with hook 1 into hole, then pull outwards again so that the hook is retained. (See Fig. 5-10)
- Tighten the hexagon nut fully.

## 8. CHANGING FUEL FILTER ELEMENT

(See Fig. 5-11)

The maintenance intervals for the fuel filter are dependent upon the purity of the diesel oil being used and, if necessary, may have to be reduced to 250 hours.

### ⚠ WARNING

**When working on the fuel system, do not expose it to naked flames; do not smoke.**

### ⚠ CAUTION

**Keep the entire area clean so that no dirt reaches the fuel. Fuel particles may damage the injection system.**

### Double fuel filter system

This system consists of a maintenance-free external filter ❶ and a replaceable-cartridge filter ❷. The advantage of this system consists in retaining dirt particles which might get into the fuel system on filter replacement, upstream of the following external filter, so that they cannot endanger the injection system.

#### ⚠ CAUTION

**This external filter ❶ must not be replaced. Only replace the fuel filter ❷, consulting with your nearest service dealer.**

## 9. DRY-TYPE AIR CLEANER (See Fig. 5-3, 12 thru 13)

However, the filter cartridge should always be replaced after 500 operating hours at the latest.

- Remove the air cleaner cover.  
(See Fig. 5-3)
- Unscrew and remove knurled nut and take off air cleaner element. (See Fig. 5-12)
  - ❶ knurled nut                      ❷ Air cleaner element
- Clean the filter compartment and the cover.  
Dirt and other foreign bodies must not be allowed to enter the engine's air inlet points.
- The filter cartridge should either be renewed or, depending upon the degree of contamination, cleaned, or checked, as follows:

### CLEANING THE FILTER CARTRIDGE

#### Dry contamination

Use compressed air to blow through the filter cartridge from the inside outwards, until no further dirt emerges. (See Fig. 5-13)

#### ⚠ CAUTION

**The pressure must not exceed 5 kg/cm<sup>2</sup>.**

#### Moist or oily contamination

Renew the filter cartridge.

### CHECKING THE FILTER CARTRIDGE

- Check filter cartridge's gasket surface for damage. (See Fig. 5-13)
  - ❶ Gasket surface

- Check the filter cartridge for cracks or any other type of damage to the paper filter by holding it inclined towards the light or by shining a light source through it.

#### ⚠ CAUTION

**The slightest damage to the paper filter rules out it being used any longer.**

- Re-assemble the filter cartridge in the reverse order of work.

## 10. OIL FILTER (See Fig. 5-14 thru 18)

The oil filter should be cleaned at the same time as the engine oil is changed, since oil escapes when the filter is removed.

The engine must be standing horizontally and switched off.

#### ⚠ WARNING

**Danger of scalding from hot oil !  
Trap the old oil and dispose of it in accordance with local legislation.**

- Loosen screw ❶ with approx. 5 rotations.  
(See Fig. 5-14)
- Remove oil filter from housing. (See Fig. 5-15)
- Use an air line to blow out oil filter dirt from the inside outwards. (See Fig. 5-16)

#### ⚠ WARNING

**Persons handling compressed air must wear protective goggles.**

- Check joint washer ❶ whether it is damaged; replacement if necessary. (See Fig. 5-17)
- Check joint washer ❷ whether it is damaged and correctly fitted, replace oil filter if necessary.
- Lubricate joint washer before fitting.
- Put in oil filter and press until limit stop.  
(See Fig. 5-18)
- Check whether tension springs sit close to oil filter with both ends ❶, before tightening screw.
- Check the oil level and restore to the **max.** level if required, page 5 "1. CHECK ENGINE OIL".

## PERIODIC OPERATION AND INSPECTION

When furnishing the generator as emergency electric power source, periodic operation and inspection are needed.

Fuel and engine oil will be deteriorated with time, and this causes that the engine is difficult to start and as the results improper engine operation and fault.

### ⚠ CAUTION

**Since the fuel will be deteriorated with time, replace fuel with fresh one periodically; once every three (3) months is recommended.**

- (a) Check the fuel, engine oil and air cleaner.
- (b) Start engine.
- (c) With appliance such as lightings activated, run the engine for over ten minutes.
- (d) Check for the following items;
  - Proper engine running.
  - Adequate output and the indicator lamp turned on properly.
  - Key switch and fuel cock normally operated.
  - No leakage of engine oil and fuel.

## TRANSPORTING

When transporting the generator, make sure that the fuel should be drained from the tank.

### ⚠ WARNING

- **To prevent fuel spillage due to the vibration and impact, never transport the generator with the fuel filled in the tank.**
- **Secure the tank cap thoroughly.**
- **To avoid the risk of the fuel flammability, never leave the generator in an area exposed to direct sunlight or high temperatures for a long time.**
- **Keep the fuel in the exclusive fuel storage tank made by steel when transporting.**

- (a) Turn the fuel cock to the CLOSE position.

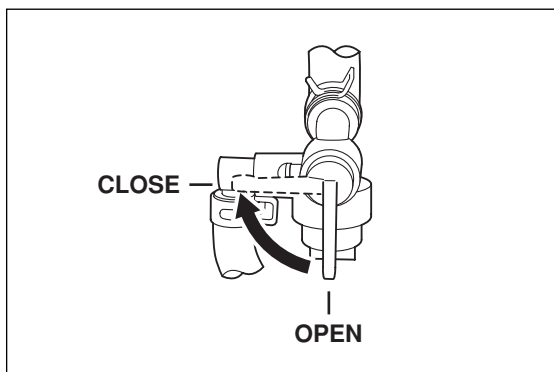

- (b) Drain the fuel from the tank.
- (c) Secure the tank cap.

### ⚠ CAUTION

- **Do not place any heavy objects on the generator.**
- **Select and place the generator in the proper position of the transport vehicle so that the generator not be moved or fallen down.**  
**Fix the generator with rope as necessary.**

## PREPARATION FOR STORAGE

The following procedures should be followed prior to storage of your generator for periods of 6 months or longer.

- Drain fuel from fuel tank carefully by disconnecting the fuel line.  
Fuel left in the fuel tank will eventually deteriorate making engine-starting difficult.
- Change engine oil.
- Check for loose bolts and screws, tighten them if necessary.
- Clean generator thoroughly with oiled cloth. Spray with preservative if available. **NEVER USE WATER TO CLEAN GENERATOR !**
- Pull starter handle until resistance is felt, leaving handle in that position.
- Store generator in a well ventilated, low humidity area.

## TROUBLESHOOTING

When generator engine fails to start after several attempts, or if no electricity is available at the output socket, check the following chart. If your generator still fails to start or generate electricity, contact your nearest Robin dealer or service shop for further information or corrective procedures.

### Engine

Malfunctions	Possible causes	Remedy
Engine does not start, or not immediately, but can be turned over easily as usual.	Speed control lever in stop or idle position.	Move lever to START position.
	No fuel in the injection pump.	Add fuel. Systematically check the entire fuel supply system: If still no fault found, - check engine feed line - check fuel filter
	Insufficient compression: - Incorrect valve clearance.	Check valve clearances, adjust if necessary.
	- Cylinders and/or piston rings worn.	See workshop manual.
	Injector not functioning.	See workshop manual.
At low temperatures.	Fuel has inadequate resistance to low temperatures.	Check whether clear (not turbid) fuel emerges at the fuel line detached from the injection pump. If turbid or separated - either warm up the engine or drain the complete fuel supply system. Refill with winter-grade fuel to which paraffin has been added.
	Starting speed below 400 min <sup>-1</sup> - Viscosity of oil too high.	Change lubricating oil and add oil of the correct viscosity class.
	- Battery charge too low.	Check the battery, if necessary contact a service station.
Engine fires but does not run.	Speed control lever not moved far enough towards „START“.	Move lever to „START“ position.
	Fuel filter blocked.	Renew fuel filter.

<b>Malfunctions</b>	<b>Possible causes</b>	<b>Remedy</b>
Starter motor does not operate or engine does not turn over.	Fault in the electrical system: - Battery and/or other cables incorrectly connected up. - Cable connections loose and/or oxidised. - Battery faulty and/or flat. - Starter motor faulty. - Faulty relays, monitoring element.	Check electrical system and its component. See also the workshop manual.
Engine cuts out of its own accord during operation.	Fuel supply interrupted - Tank has run empty. - Fuel filter blocked. - Tank venting inadequate. - Air in the fuel system.  Mechanical faults.	Add fuel. Change fuel filter. Ensure adequate tank venting. Check fuel system for penetration of air. Check air vent valve.  Contact a ROBIN service station.
Engine output and speed both drop.	Fuel supply interrupted: - Tank has run empty. - Fuel filter blocked. - Tank breathing inadequate. - Air in the fuel system.  - Speed control lever does not remain in desired position.	Add fuel. Change fuel filter. Provide adequate tank breathing. Check fuel system for penetration of air. Check air vent valve.  Lock the lever into position.
Engine output and speed fall, black smoke from exhaust.	Air cleaner contaminated.  Valve clearances incorrect.  Injector not functioning.	Clean or renew the air cleaner.  Adjust valve clearances.  See workshop manual.
Engine becomes very hot. Indicator lamp for cylinder temperature comes on.	Too much lubricating oil in engine.  Inadequate cooling: - Contamination of entire cooling air zone.  - Air duct panels not properly sealed.	Drain off lubricating oil as far as upper mark on dipstick.  Clean cooling air zone.  Check cooling air deflector plates and shafts for completeness and airtight seal.
Moisture condensate emerging from exhaust.	Operation off load for a prolonged period.	Operate the machine at about 70 % load until moisture no longer emerges from the exhaust.

### When No Electricity Is Generated at Receptacle:

Check to make sure AC circuit breaker or AC circuit breaker is in the "ON" position.	↔	After making sure that the total wattage of the electrical appliance is within permissible limits and there are no defects in the appliance, turn the AC breaker to the "ON" position. If breakers continue to actuate, consult your nearest servicing dealer.
Check AC receptacle and DC terminals for loose connection.	↔	Secure connection if necessary.
Check to see if engine starting was attempted with appliances already connected to generator.	↔	Turn off switch on the appliance, and disconnect cable from receptacle. Reconnect after generator has been started properly.

# SPECIFICATIONS

Model		RGD3300H	RGD5000H	
GENERATOR	Type	Brushless, self-exciting, 2-poles, single phase		
	Voltage regulator	Condenser type		
	AC output	Frequency (Hz)	60	
		Rated voltage (V)	120, 120/240	
		Rated output (VA)	3000	4500
		Maximum output (VA)	3300	5000
	DC output (V-A)	12-8.3		
	Power factor	1.0		
	Over current protector	No-fuse Breaker		
Noise level at rated output (dB-7m)	77.5	79.7		
ENGINE	Model	1B30	1B40	
	Type	Air-cooled, 4-cycle, single cylinder diesel engine		
	Displacement (ml)[cu.in.]	347 [21.17]	462 [28.19]	
	Fuel	Automobile diesel light oil		
	Fuel tank capacity (L)[US gal.]	12.0 [3.17]		
	Continuous operating hours at rated output (h)	8.5	5.9	
	Starting system	Electric and Recoil starter		
	Dimensions L×W×H (mm) [in.]	790×515×576 [31.10×20.28×22.68]		
Dry Weight (kg)[lb]	87 [191.8]	104 [229.3]		

Specifications are subject to change without notice.



# WIRING DIAGRAM

## RGD3300H (60Hz-120/240V)

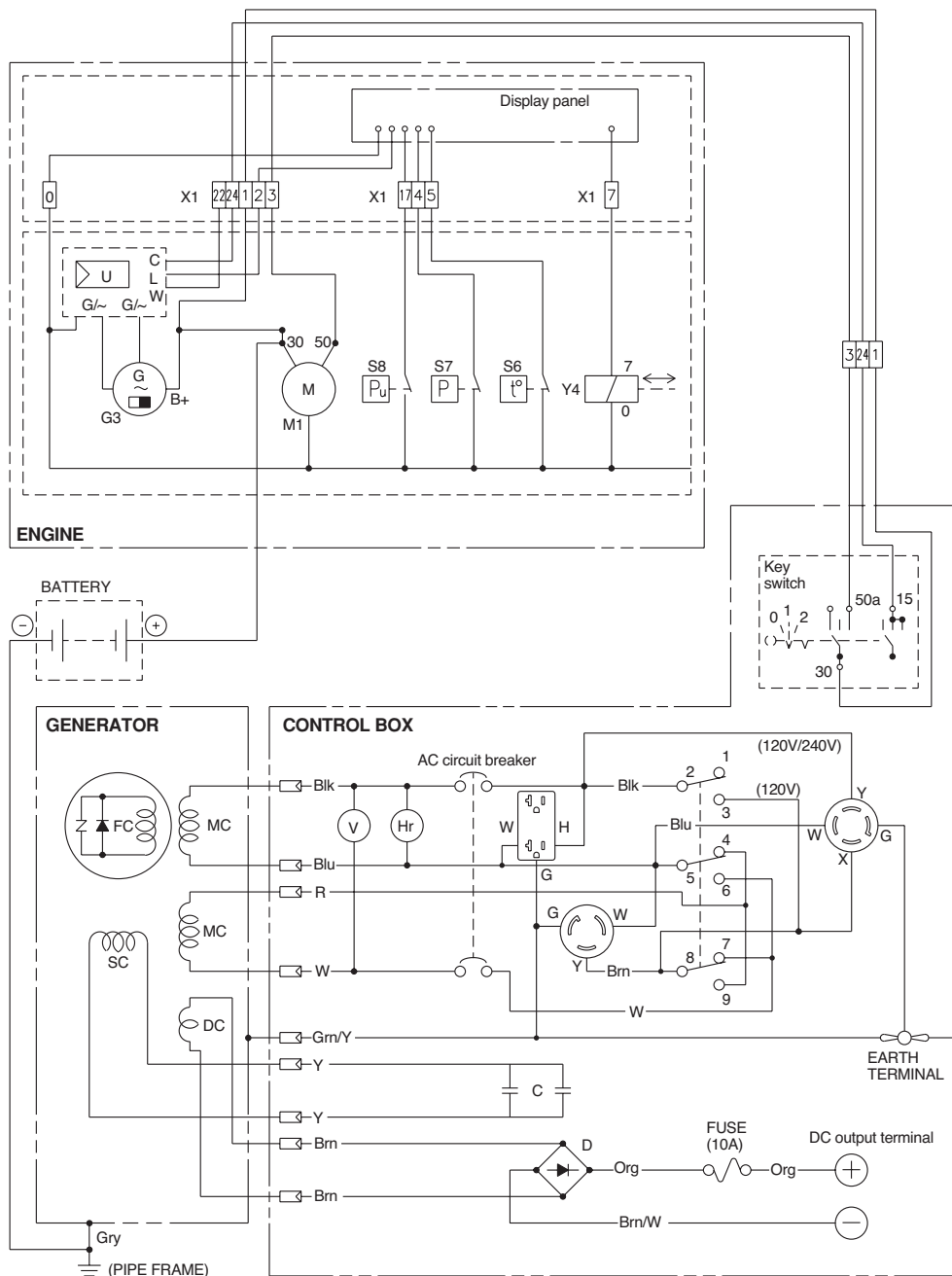

### Wiring color cord

Blk : Black	Org : Orange	W : White	Brn/W : Brown/White
R : Red	Brn : Brown	Gry : Gray	
Blu : Blue	Y : Yellow	Grn/Y : Green/Yellow	

# RGD5000H (60Hz-120/240V)

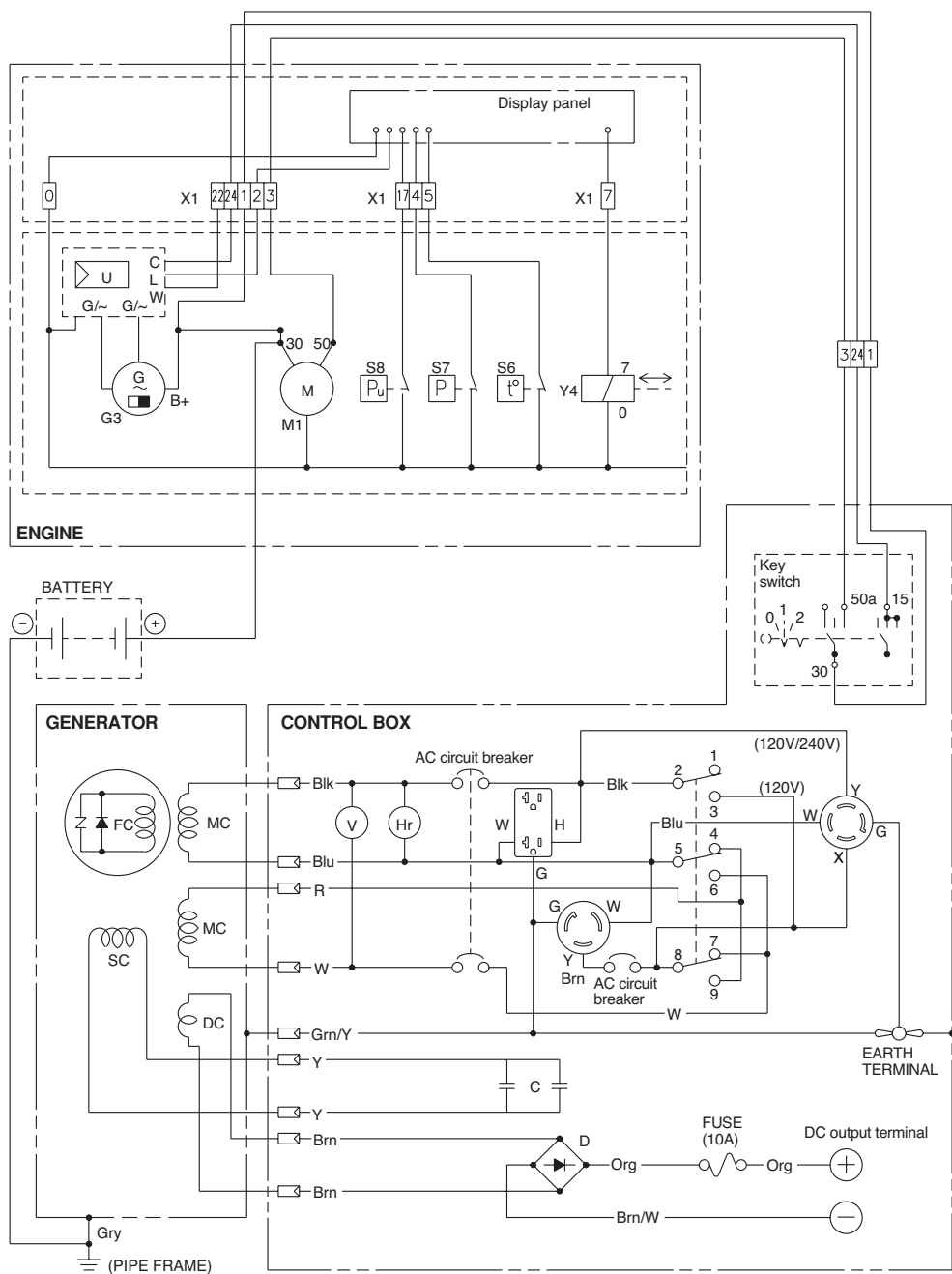

**Wiring color cord**

Blk : Black	Org : Orange	W : White	Brn/W : Brown/White
R : Red	Brn : Brown	Gry : Gray	
Blu : Blue	Y : Yellow	Grn/Y : Green/Yellow	

ISSUE EMD-GU2359



**SUBARU**

**FUJI HEAVY INDUSTRIES LTD.  
INDUSTRIAL PRODUCTS COMPANY**

4-410 ASAHI, KITAMOTO-SHI, SAITAMA, 364-8511, JAPAN  
TEL:+81-48-593-7798, FAX:+81-48-593-7946  
<http://www.fhi.co.jp/robin/>

PRINTED IN JAPAN  
April 2007

## Free Manuals Download Website

<http://myh66.com>

<http://usermanuals.us>

<http://www.somanuals.com>

<http://www.4manuals.cc>

<http://www.manual-lib.com>

<http://www.404manual.com>

<http://www.luxmanual.com>

<http://aubethermostatmanual.com>

Golf course search by state

<http://golfingnear.com>

Email search by domain

<http://emailbydomain.com>

Auto manuals search

<http://auto.somanuals.com>

TV manuals search

<http://tv.somanuals.com>