

Robin Industrial Engines®

SERVICE MANUAL

Models

EY15V, EY20V

1193S104



ROBIN AMERICA, INC.
ROBIN TO WISCONSIN ROBIN
ENGINE MODEL CROSS REFERENCE LIST

ROBIN

WISCONSIN ROBIN

SIDE VALVE

EY08	W1-080
EY15	W1-145
EY15V	W1-145V
EY20	W1-185
EY20V	W1-185V
EY23	W1-230
EY28	W1-280
EY35	W1-340
EY40	W1-390
EY45V	W1-450V
EY21	EY21W
EY44	EY44W
EY18-3	EY18-3W
EY25	EY25W
EY27	EY27W

OVERHEAD VALVE

EH11	WO1-115
EH12	WO1-120
EH15	WO1-150
EH17	WO1-170
EH21	WO1-210
EH25	WO1-250
EH30	WO1-300
EH30V	WO1-300V
EH34	WO1-340
EH34V	WO1-340V
EH43V	WO1-430V

TWO CYCLE

EC13V	WT1-125V
-------	----------

DIESEL

DY23	WRD1-230
DY27	WRD1-270
DY30	WRD1-300
DY35	WRD1-350
DY41	WRD1-410

CONTENTS

<i>Section</i>	<i>Title</i>	<i>Page</i>
1.	SPECIFICATIONS	1
2.	PERFORMANCE	2
2-1	Maximum Output	2
2-2	Continuous Rated Output	2
2-3	Maximum Torque and Fuel Consumption Ratio at Max. Output	2
3.	FEATURES	3
4.	GENERAL DESCRIPTION of ENGINE CONSTRUCTION	4
4-1	Cylinder, Crankcase	4
4-2	Main Bearing Cover	4
4-3	Crankshaft	4
4-4	Connecting Rod and Piston	5
4-5	Camshaft	5
4-6	Valve Arrangement	5
4-7	Cylinder Head	6
4-8	Governor	6
4-9	Cooling	6
4-10	Lubrication	6
4-11	Ignition	7
4-12	Carburetor	7
4-13	Air Cleaner	7
4-14	Sectional View of Engine	8
5.	DISASSEMBLY and REASSEMBLY	12
5-1	Preparation and Suggestion	12
5-2	Special Tools	12
5-3	How To Disassemble	14
5-4	How To Reassemble	18
6.	MAGNETO	28
6-1	Magneto	28
6-2	Breaker Point Adjustment	28
6-3	Timing Adjustment	29
6-4	Magneto Trouble Shooting	30
6-5	Solid State Ignition	30

<i>Section</i>	<i>Title</i>	<i>Page</i>
7.	GOVERNOR ADJUSTMENT	31
8.	CARBURETOR	33
8-1	Operation and Construction	33
8-2	Disassembly and Reassembly	34
9.	BRAKE-IN OPERATION of REASSEMBLED ENGINE	36
10.	ROBIN SOLID STATE IGNITION ENGINE	37
10-1	Features	37
10-2	Basic Theory of T.I.C.	37
11.	TROUBLE SHOOTING	38
11-1	Starting Difficulties	38
11-2	Engine Misfires	39
11-3	Engine Stops	39
11-4	Engine Overheat	39
11-5	Engine Knocks	40
11-6	Engine Backfires through Carburetor	40
12.	INSTALLATION	41
12-1	Installing	41
12-2	Ventilation	41
12-3	Exhaust Gas Discharge	41
12-4	Power Transmission to Driven Machines	41
12-5	Wiring	42
13.	CHECKS and CORRECTIONS	43
14.	TABLE of CORRECTION STANDARDS	44
15.	MAINTENANCE and STORING	49
15-1	Daily Checks and Maintenance	49
15-2	Every 20 Hours Checks and Maintenance	49
15-3	Every 50 Hours (10 days) Checks and Maintenance	49
15-4	Every 100 ~ 200 Hours (Monthly) Checks and Maintenance	49
15-5	Every 500 ~ 600 Hours (Semiannual) Checks and Maintenance	50
15-6	Every 1000 Hours (Yearly) Checks and Maintenance	50
15-7	Preparation for Long Abeyance	50

1. SPECIFICATIONS

Model	EY15V	EY20V
Type	Air-Cooled, 4-Cycle, Vertical Shaft, Single Cylinder Gasoline Engine	
Bore x Stroke (in)	63 mm x 46 mm (2.48" x 1.81")	67 mm x 52 mm (2.64" x 2.05")
Piston Displacement (cu. in)	143 cc (8.73 cu. in)	183 cc (11.17 cu. in)
Compression Ratio	6.3	
Continuous Rated Output (HP/rpm)	2.2/3,000 2.7/3,600	3/3,000 3.5/3,600
Max. Output (HP/rpm)	3.5/3,600	4.6/3,600
Max. Torque (kg-m/rpm)	0.7/2,800	0.95/2,800
Rotation	Counter-clockwise facing to P.T.O. shaft	
Cooling System	Forced Air Cooling	
Lubrication	Splashing Type	
Lubricant	Automobile Oil Class SC	
Carburetor	Horizontal Draft, Flat Type	
Fuel	Automobile Gasoline	
Fuel Consumption Ratio (gr/HP-h)	280 at continuous rated output operation	
Fuel Feed	Gravity Type	
Fuel Tank Capacity	Approx. 1.5 liter (0.4 U.S. gal.)	
Reduction Ratio	-	
Speed Governor	Centrifugal Flyweight Type	
Ignition System	Flywheel Magneto Type (Solid State Ignition is available as option.)	Flywheel Magneto Type (Solid State Ignition is standard.)
Spark Plug	NGK BM4A	
Starting System	Recoil Starter (Rope Type is available, if required.)	
Dry weight (lbs.)	12.7 kg (28 lbs.)	14.5 kg (31.9 lbs.)
Length (in)	371 mm (14.6")	383 mm (15.08")
Dimensions Width (in)	305 mm (12.0")	311 mm (12.24")
Height (in)	344 mm (13.5")	356 mm (14.02")

2. PERFORMANCE

2-1 MAXIMUM OUTPUT

The maximum output of an engine is such standard power as developed by the engine, after its initial break-in period with all the moving parts properly worn in, when operating with a fully open throttle valve. Therefore, a new engine may not develop the maximum output in the beginning because the moving parts are not in a properly worn-in condition.

2-2 CONTINUOUS RATED OUTPUT

The continuous rated output of an engine is such power as developed by that engine when running continuously at an optimum speed, and most favorable from the viewpoint of engine life and fuel consumption ratio, with the governor in operation. It is suggested, therefore, that when designing a driving system for any mechanism, with this engine as prime mover, the continuous power requirement of that mechanism be kept below the continuous rated output specified.

2-3 MAXIMUM TORQUE and FUEL CONSUMPTION RATIO at MAXIMUM OUTPUT

These mean the maximum torque of the output shaft and fuel consumption ratio at the maximum output of an engine.

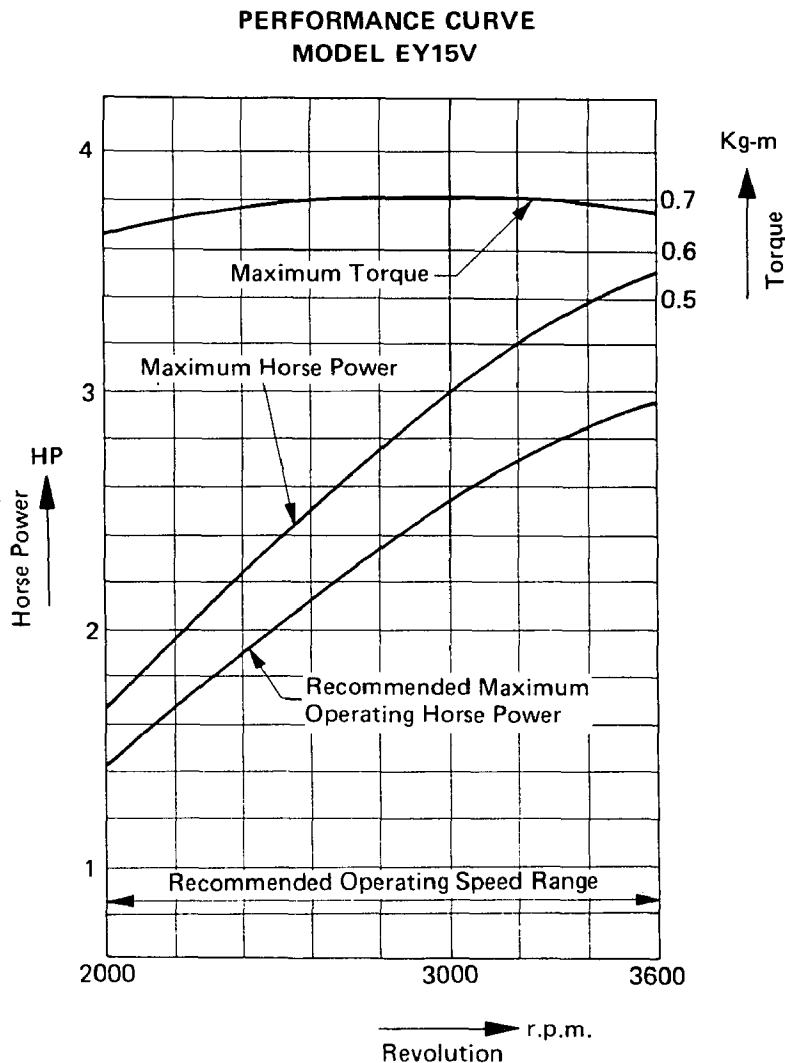

PERFORMANCE CURVE
MODEL EY20V

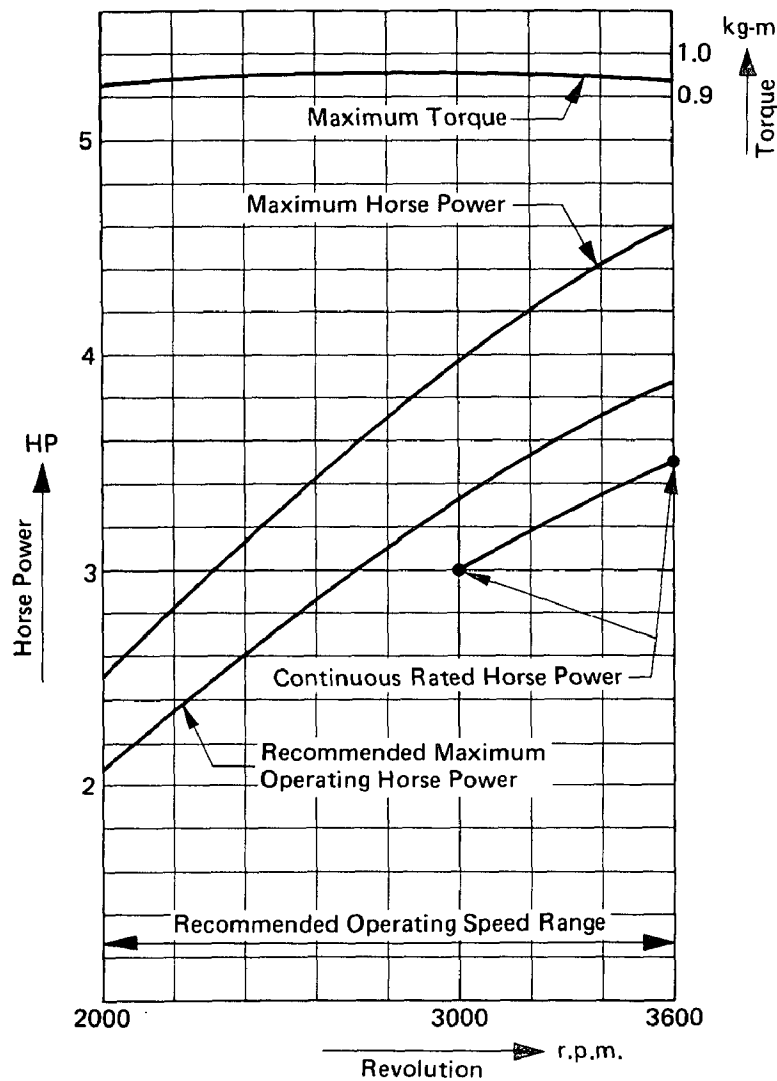

3. FEATURES

1. Compact, lightweight, durable, powerful 4-cycle air-cooled engine embodying ingenious design techniques and skilful workmanship.
2. Simple construction, smart appearance, maximum easiness of start owing to automatic decompression device
3. For EY15V engine Pointless Solid State ignition system is newly adopted for preventing poor igniting as option, and EY20V engine is equipped with Pointless Solid State ignition system as standard specifications.
4. Reliable prime mover for variety of purposes with smooth speed control by a governor under varying load conditions.
5. Economical because fuel consumption is very low.
6. Great versatility in installation by adopting recoil starter with eight different rope-pull directions and oil drain available at bottom and carburetor side of engine, as standard specifications.

4. GENERAL DESCRIPTION of ENGINE CONSTRUCTION

4-1 CYLINDER, CRANKCASE

The cylinder and crankcase are single piece aluminum die casting. The cylinder liner, made of special cast iron, is built into the aluminum casting. The intake and exhaust ports are located on one side of the cylinder, and are also inserted into the casting. The crankcase is separable on the output shaft side, where the main bearing cover is attached to it. (See Fig. 1.)

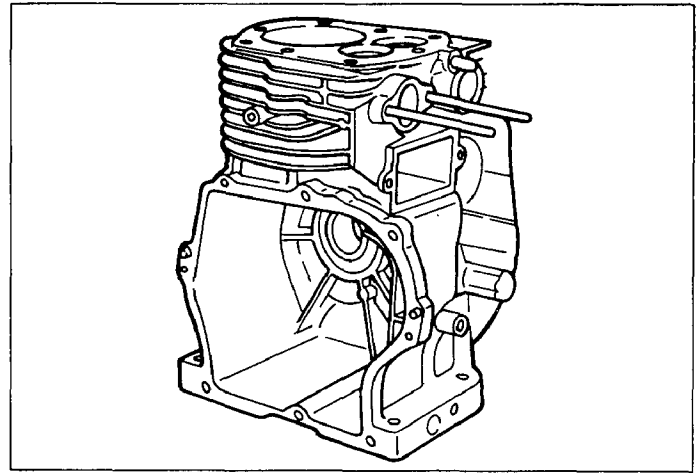

Fig. 1

4-2 MAIN BEARING COVER

The main bearing cover made of aluminum die casting is built onto the output shaft side of the crankcase so that the inside of the engine can readily be checked by simply removing the cover. It is provided with a flange and boss for directly mounting on the machines. Two oil drains are also available. (See Fig. 2 and Fig. 3.)

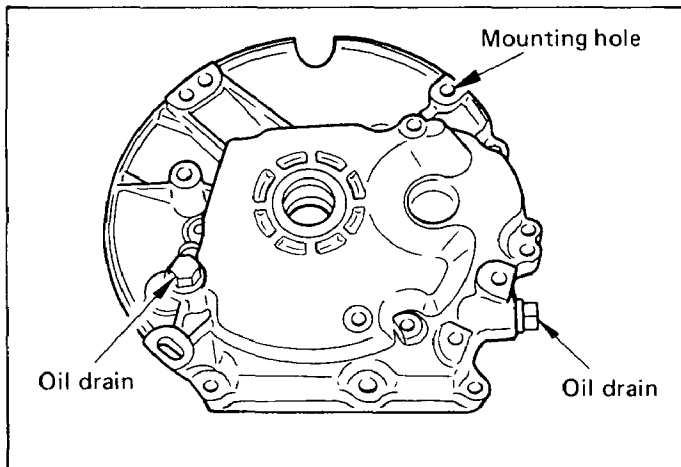

Fig. 2

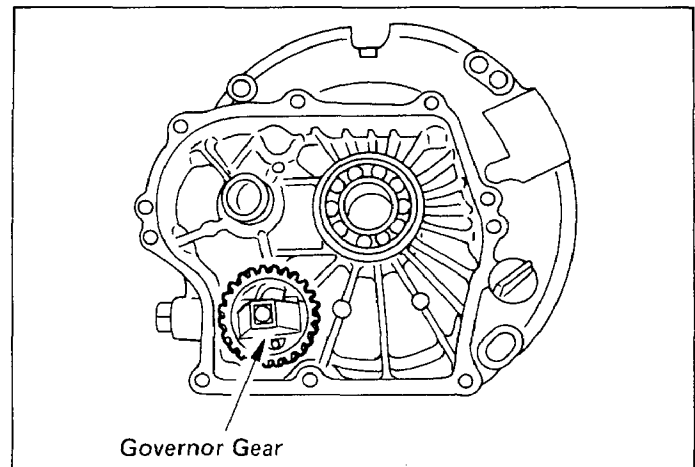

Fig. 3

4-3 CRANKSHAFT

The crankshaft is forged of carbon steel, and the crankpin is induction-hardened. It has a crank gear and a oil scraper press-fitted on the output end. (See Fig. 4.)

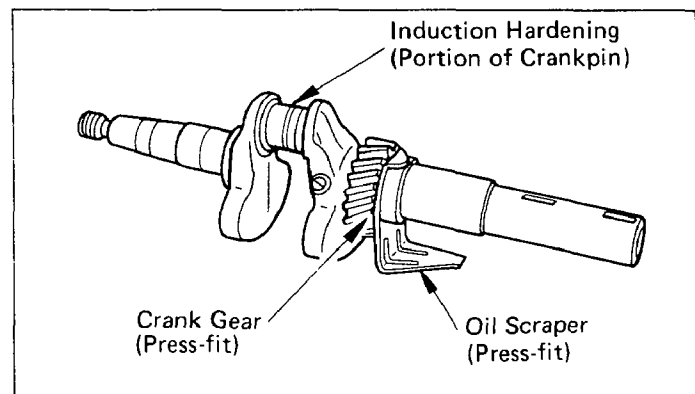

Fig. 4

4-4 CONNECTING ROD and PISTON

The connecting rod is forged of aluminum alloy, which itself serves as bearings at both the large and small ends.

The piston is cast of aluminum alloy, and has grooves for receiving two compression rings and one oil ring. (See Fig. 5.)

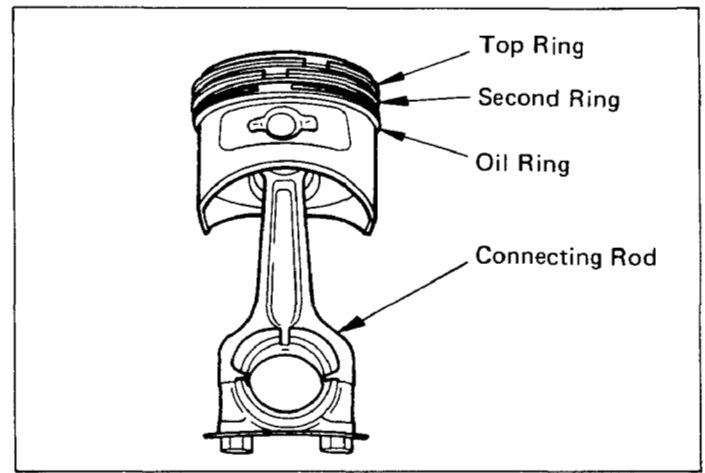

Fig. 5

4-5 CAMSHAFT

The camshafts are integrally built with a cam gear of special cast iron, and have intake and exhaust cams. Also the camshafts have aluminum plain bearing attached to both ends. (No ball bearing is used.)

(See Fig. 6.)

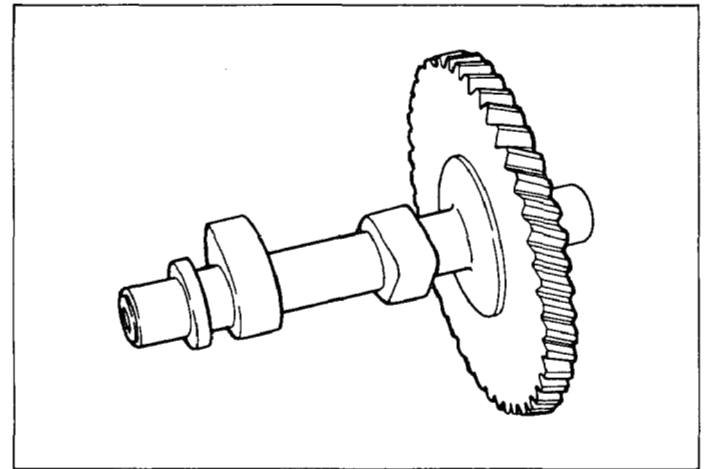

Fig. 6

4-6 VALVE ARRANGEMENT

The exhaust valve is located upstream of the cooling air with the result that the exhaust valve is intensively cooled for improved engine durability. The inner side of the valve head is reinforced with hard alloy fused to it for added durability. (See Fig. 7.)

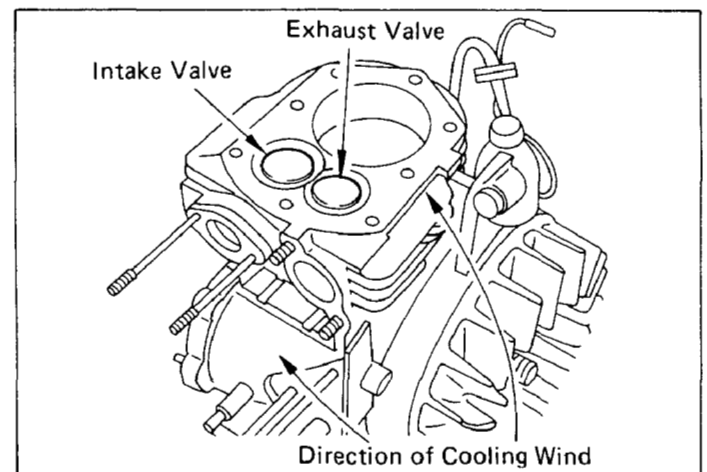

Fig. 7

4-7 CYLINDER HEAD

The cylinder head is an aluminum die casting, and forms a Ricardo type combustion chamber with ample area for high combustion efficiency.

(See Fig. 8.)

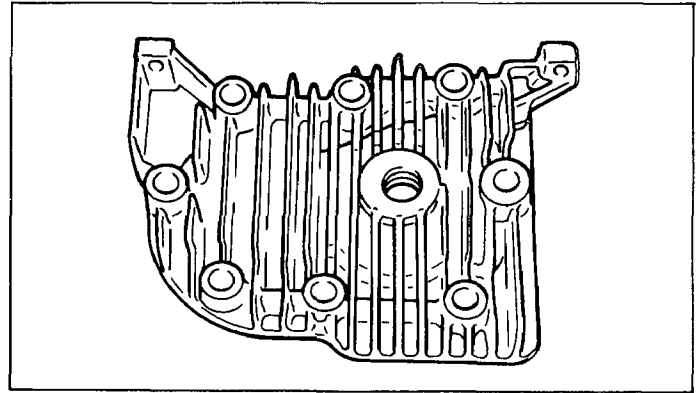

Fig. 8

4-8 GOVERNOR

The governor is a centrifugal flyweight type which permits constant operation at the selected speed against load variations. Governor gear is installed on the bearing cover without fail, and it engages with the cam gear after reassembling.

(See Fig. 9.)

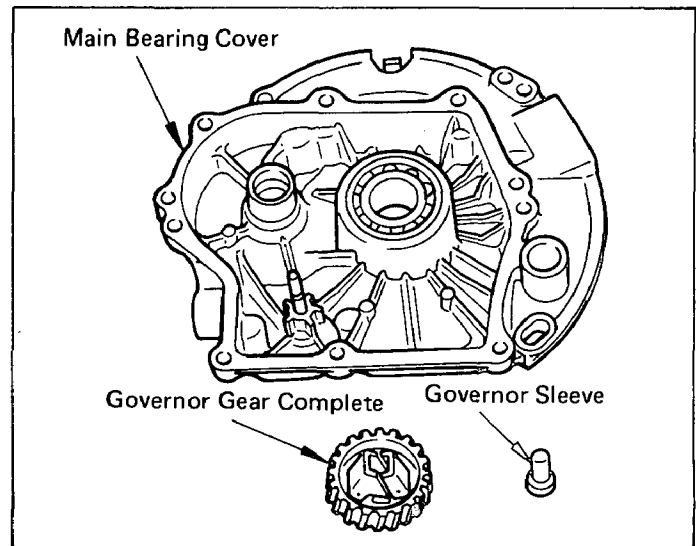

Fig. 9

4-9 COOLING

The cooling fan serving also as a flywheel cools the cylinder and cylinder head by forced air cooling. Cylinder baffles is provided for guiding the cooling air.

4-10 LUBRICATION

The rotating and sliding parts are being lubricated by scooping and splashing the oil in the crankcase with the oil scraper attached to the crankshaft.

(See Fig. 10.)

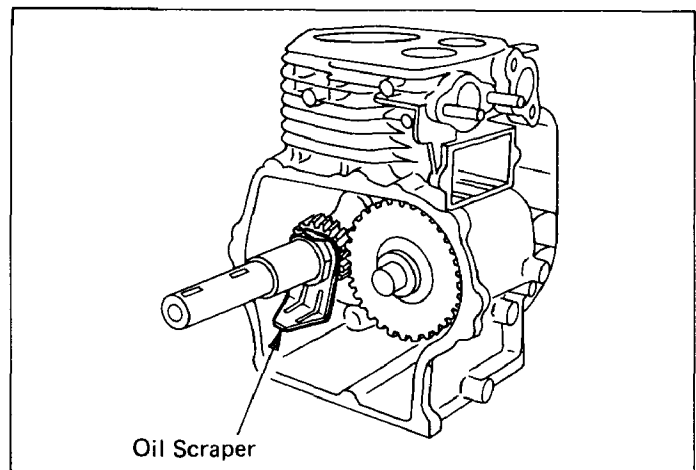

Fig. 10

4-11 IGNITION

The ignition system is a flywheel magneto type with ignition timing set at 23° before TDC. The magneto is composed of a flywheel and ignition coil. The flywheel serving also as a fan is mounted directly on the crankshaft, and the ignition coil in the crankcase. (For further details, refer to Section the Magneto.) (See Fig. 11 and Fig. 12.)

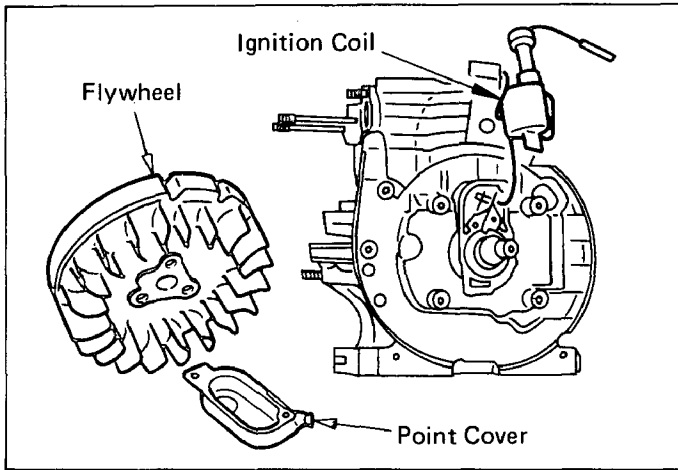

Fig. 11

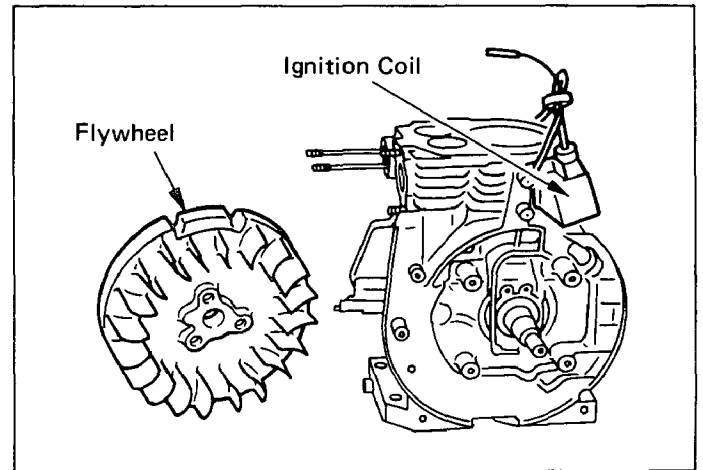

Fig. 12

4-12 CARBURETOR

A horizontal draft carburetor is employed. It has been carefully set after thorough tests to assure satisfactory start up, acceleration, fuel consumption, output performance, etc.

For construction and other details, refer to the Section on Carburetor Construction, Disassembly and Reassembly.

(See Fig. 13.)

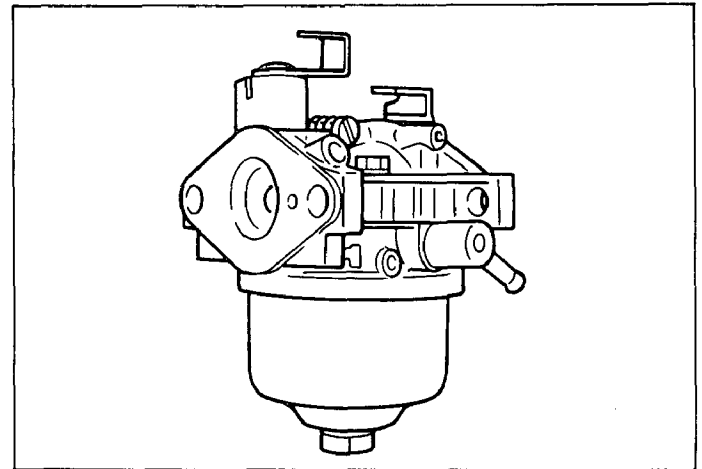

Fig. 13

4-13 AIR CLEANER

The air cleaner of the standard type engine is an oblong type using a sponge element.

(See Fig. 14.)

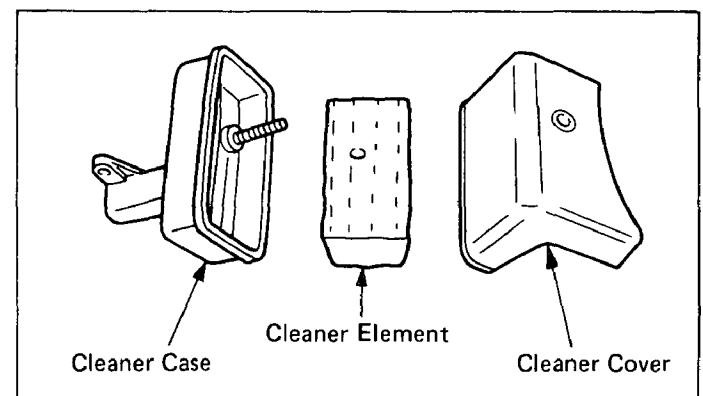
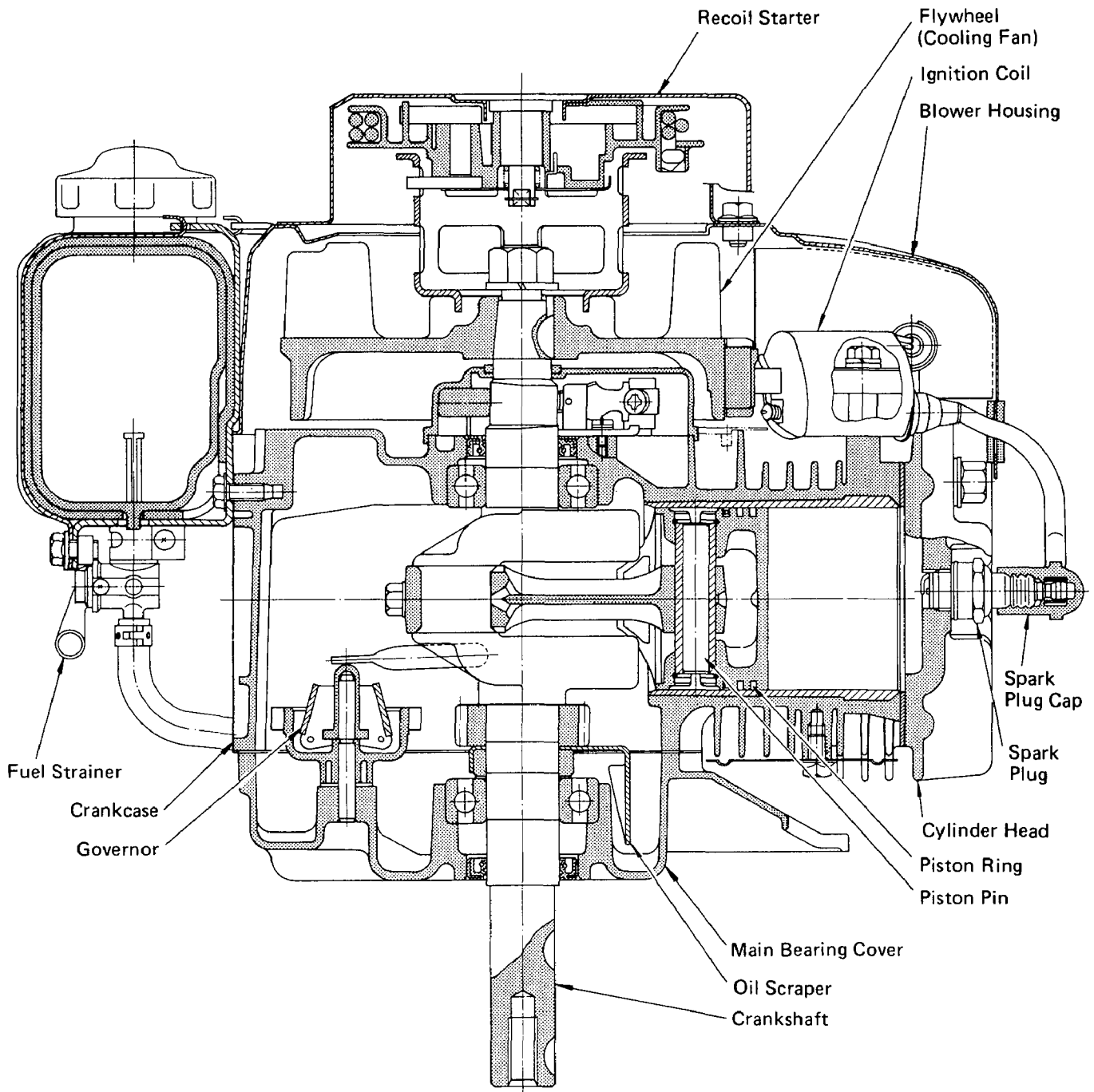
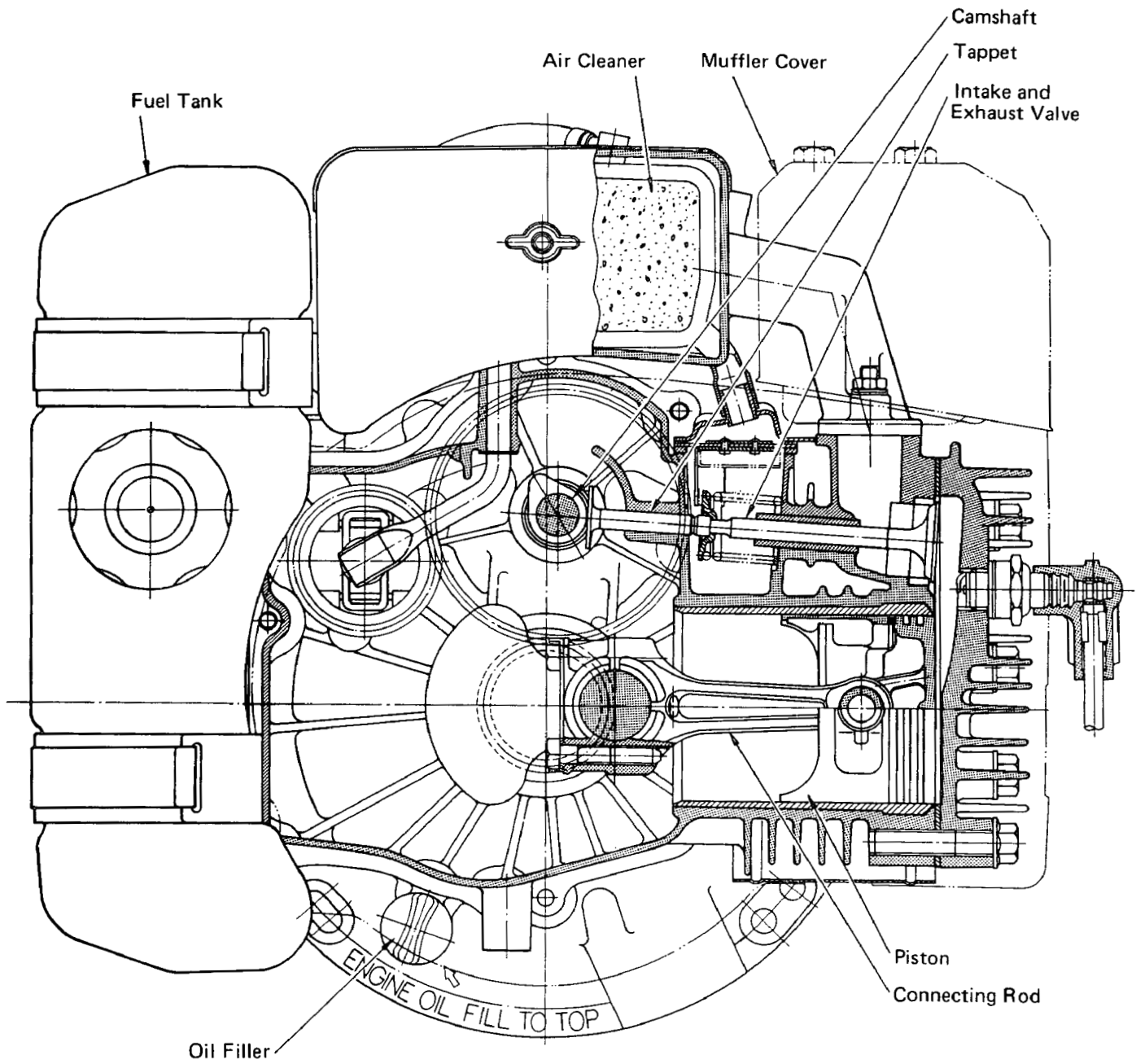

Fig. 14

4-14 SECTIONAL VIEW of ENGINE



MODEL EY15V



MODEL EY15V

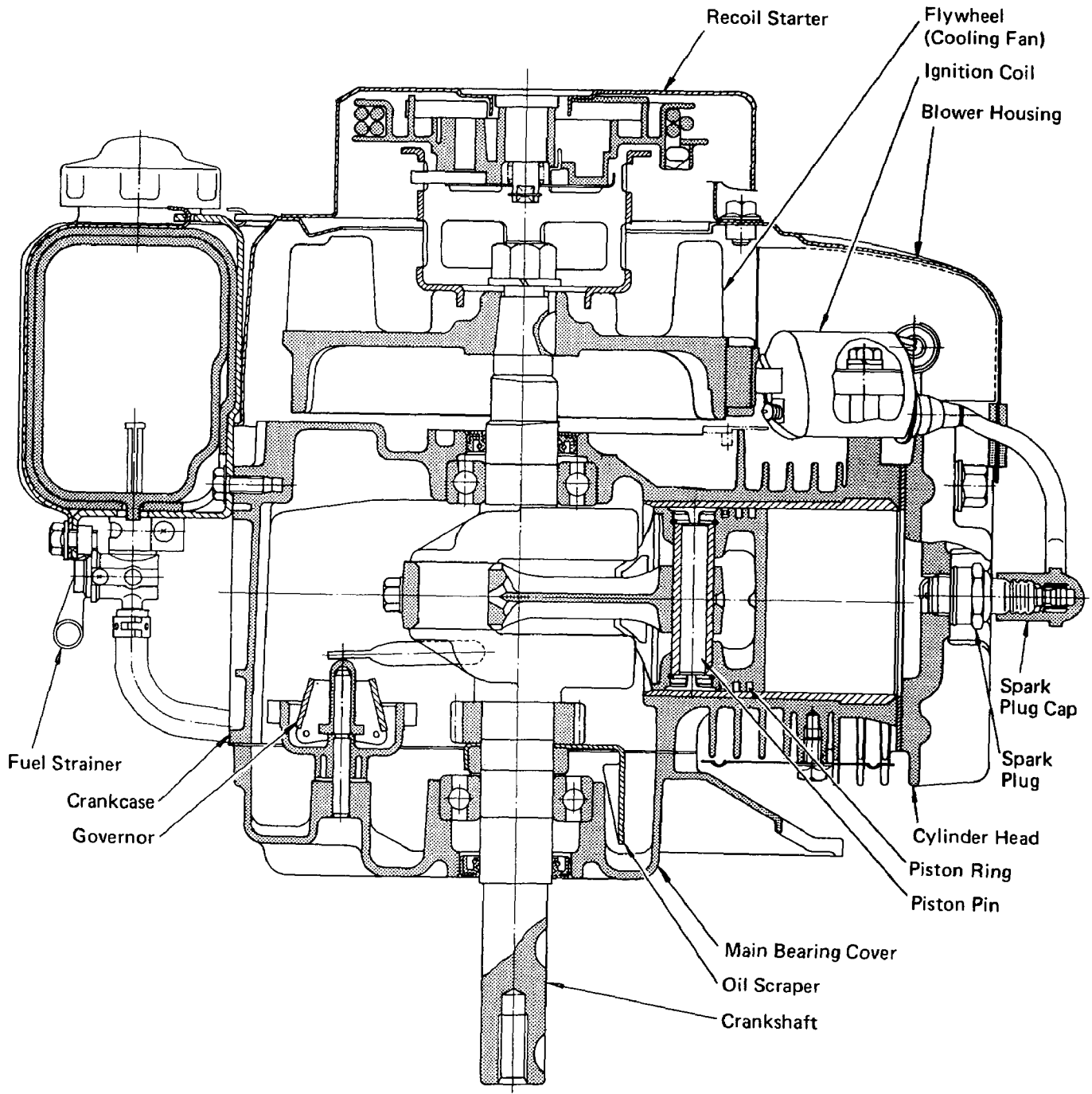

MODEL EY20V

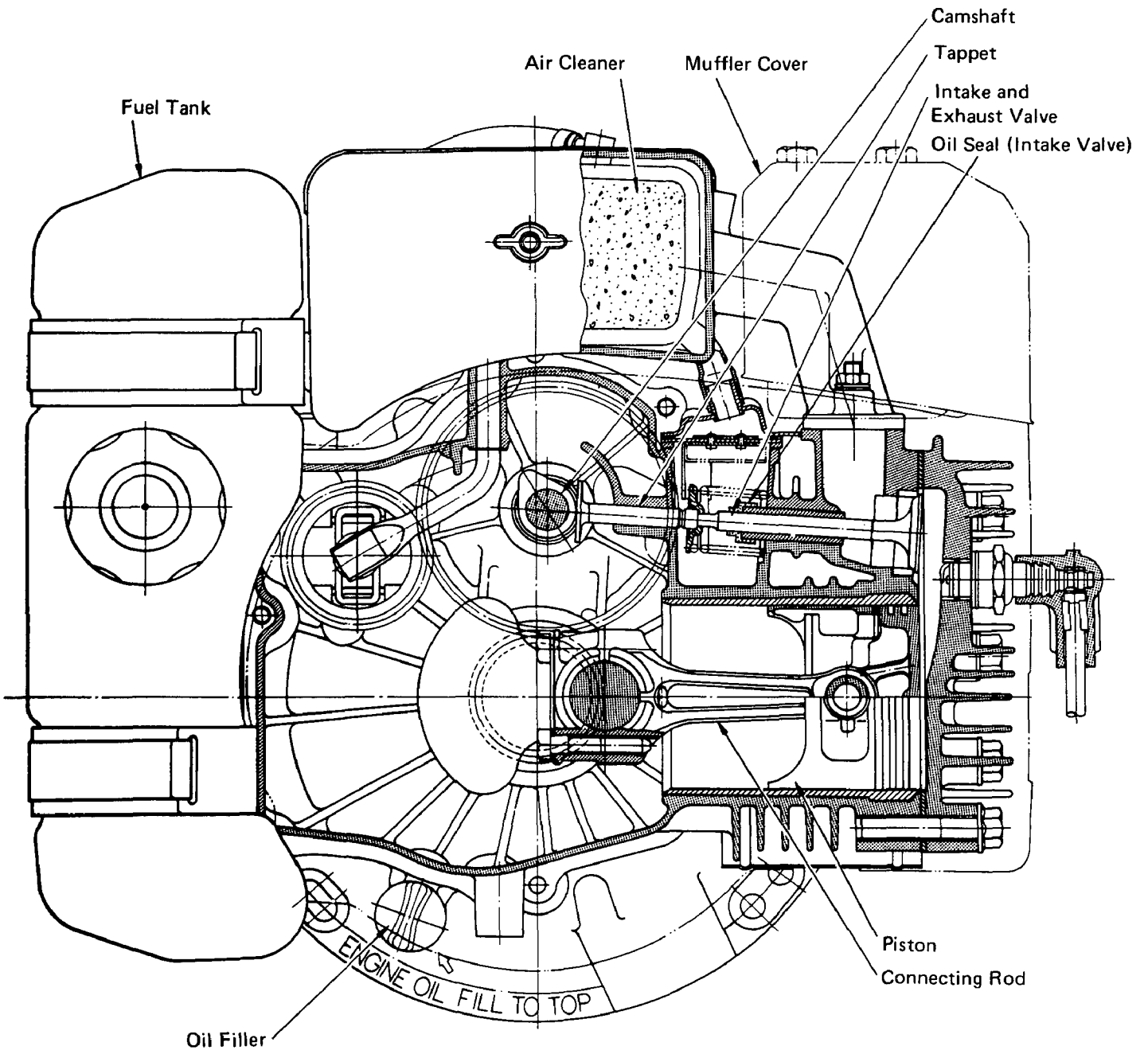

MODEL EY20V

5. DISASSEMBLY and REASSEMBLY

5-1 PREPARATIONS and SUGGESTIONS

- 1) When disassembling the engine, remember well the locations of individual parts so that they can be reassembled correctly. If you are uncertain of identifying some parts, it is suggested that tags be attached to them.
- 2) Have boxes ready to keep disassembled parts by group.
- 3) To prevent missing and misplacing, temporarily assemble each group of disassembled parts.
- 4) Carefully handle disassembled parts, and clean them with washing oil.
- 5) Use the correct tools in the correct way.

5-2 SPECIAL TOOLS

For your reference, the following shows special tools of Robin Engine for Disassembly, Measuring and Inspection Instruments.

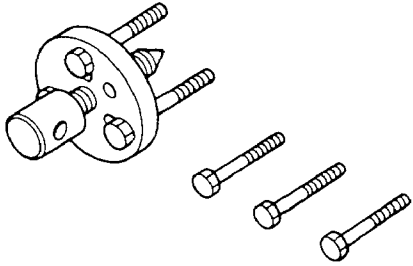
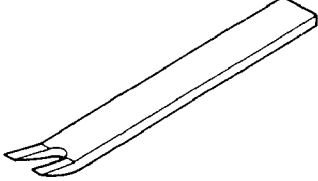
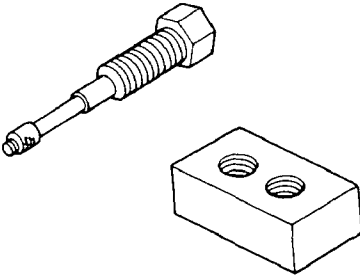
Part No.	Tool	Use	Applicable Model	Shape
209 95004 07	Flywheel Puller (with bolt)	For pulling off Flywheel	EY10, 13, 14 EY15, 18, 20 EY25, 27, 33 EY35, 40, 44 EC05, 07, 10 EC17, 25, 37	
207 95003 07	Valve Spring Retainer	For mounting and dismounting Valve Spring Retainer and Retainer Lock	EY10, 13, 14 EY15, 18, 20 EY25, 27, 33 EY35, 40, 44	
205 95001 07	Valve Guide Puller	For pulling off Valve guide	EY13, 14	

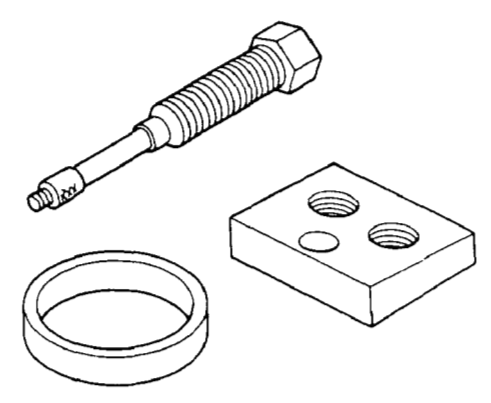
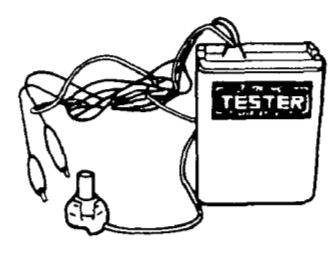
Part No.	Tool	Use	Applicable Model	Shape
206 95001 07	Valve Guide Puller	For pulling off Valve guide	EY18	
227 95001 07			EY15, 20	
207 95001 07			EY25, 27	
M-20248	Timing Tester	For adjusting timing	EY10, 13, 14 EY15, 18, 20 EY25, 27, 33 EY35, 40, 44 EC03, 04, 05 EC07, 10, 17 EC25, 37	

5-3 HOW TO DISASSEMBLE

*Length of the bolt indicates the length from the bolt head bottom surface to the threaded end.

Order	Item	Procedures	Remarks	Tool
1	Recoil starter	(1) Remove the recoil starter. 6φ × 8 mm bolt: 4 pcs.		10 mm box spanner
2	Fuel tank	(1) Close the fuel cock. (2) From the carburetor disconnect the fuel pipe between the fuel strainer and carburetor on the side of the carburetor. (3) Remove the tank band and fuel tank from the fuel tank bracket. 6φ × 12 mm bolt: 2 pcs.		10 mm box spanner 10 mm box spanner
3	Muffler and muffler cover	(1) Remove the muffler and muffler cover from the cylinder portion of the crankcase. 8φ × 100 mm bolt: 2 pcs. (EY15V) 8φ × 106 mm bolt: 2 pcs. (EY20V)	Note that the EY20V has 2 sheets of gasket and 1 sheet of flange between the muffler and cylinder.	12 mm box spanner or 12 mm spanner
4	Air cleaner	(1) Remove the air cleaner cover and element. (2) Loosen the intake manifold mounting nut. 6φ nut: 2 pcs. (3) Remove the air cleaner case from the carburetor and fuel tank bracket. 6φ nut: 2 pcs. 6φ × 14 mm bolt: 1 pce. (4) Disconnect the breather pipe.	Air cleaner is fastened together with the carburetor.	10 mm box spanner
5	Governor lever and the relative parts	(1) Remove the choke lever from the fuel tank bracket and remove the choke rod from the carburetor. Special bolt: 1 pce. (2) Remove the governor lever from the governor lever shaft. 6φ × 25 mm bolt: 1 pce. (3) Remove the governor rod and rod spring from the carburetor. (4) Remove the governor spring from the speed control lever.	Special bolt Just loosen the bolt, unnecessary to the	14 mm box spanner or 14 mm spanner 10 mm box spanner
6	Carburetor	(1) Remove the carburetor from the intake manifold.		
7	Intake manifold	(1) Remove the intake manifold from the cylinder portion of the crankcase. 6φ nut: 2 pcs.		10 mm box spanner
8	Fuel tank bracket	(1) Remove the fuel tank bracket from the crankcase. 6φ × 14 mm self-tapping bolt: 2 pcs. 6φ × 10 mm bolt: 2 pcs.		10 mm box spanner

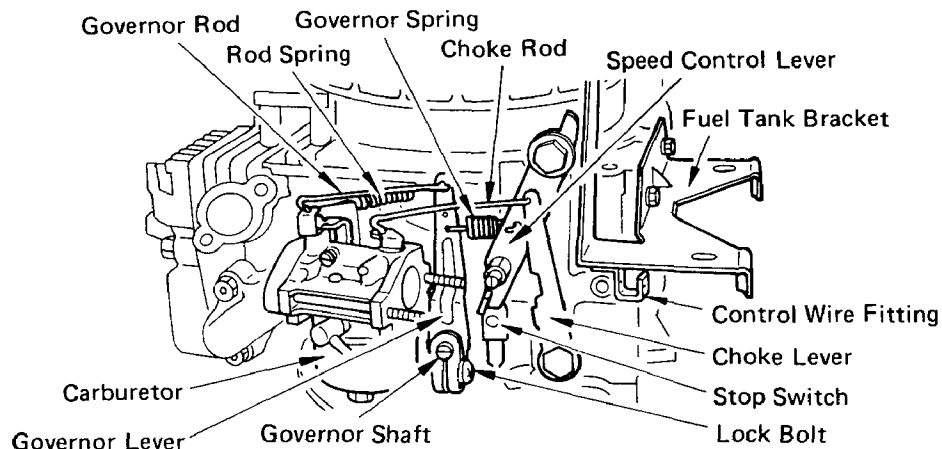

Fig. 15

Order	Item	Procedures	Remarks	Tool
9	Starting pulley	(1) Remove the starting pulley from the flywheel. 14φ nut: 1 pce. Fit a box or socket wrench over the flywheel nut, and strike it hard with a hammer to remove the 14 mm nut and spring washer.	Be careful to damage the blades of the flywheel with a driver and the like. Strike counterclockwise with a hammer. (See Fig. 16.)	19 mm box spanner or socket wrench
10	Flywheel	(1) Remove the flywheel from the crankshaft.	Fit the flywheel puller as per Fig. 17, turn the center bolt clockwise and pull out the flywheel.	

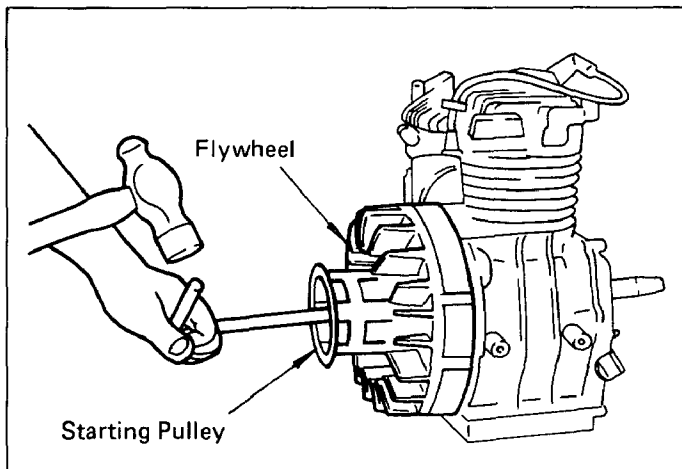

Fig. 16

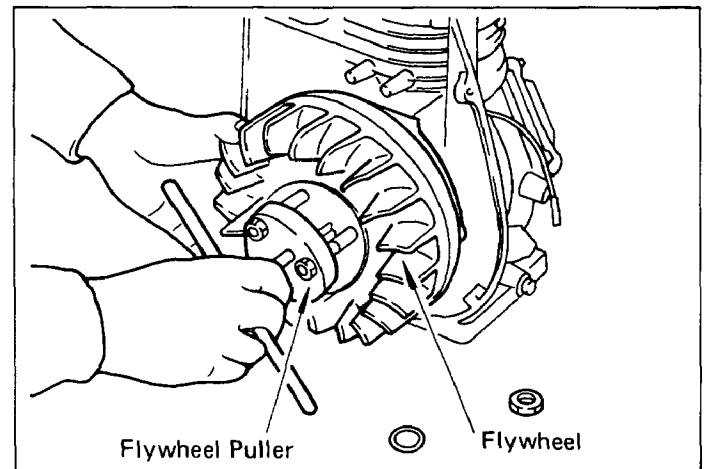
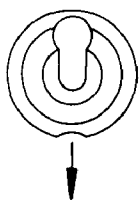

Fig. 17

Order	Item	Procedures	Remarks	Tool
11	Ignition coil	(1) Remove the ignition plug cap from the ignition plug; and remove the ignition coil from the crankcase.	Sems bolt	10 mm box spanner
12	Ignition plug	(1) Remove the ignition plug from the cylinder head.		19 mm box spanner
13	Cylinder head	(1) Remove the 8 mm bolt and remove the cylinder head from the crankcase. 8φ × 40 mm bolt: 8 pcs. (2) Remove the cylinder head gasket from the crnkcase.		12 mm box spanner

Order	Item	Procedures	Remarks	Tool
14	Intake and exhaust valve	<ol style="list-style-type: none"> (1) Remove the inner and outer tappet covers from the crankcase. 6φ × 12 mm bolt: 2 pcs. (2) Pull out the intake and exhaust valves. (3) Remove the valve spring and the valve retainer. 	<p>Put the notch on the outer circumference of the spring retainer on this side.</p> <p>Hook the medium size (-) driver at the dent (lower side) of the spring retainer and pull out the valves, while pulling the spring retainer toward you.</p> <p>(See Fig. 18.)</p>	<p>10 mm box spanner</p>  <p>The front is this side. (-) driver</p>
15	Main bearing cover	<ol style="list-style-type: none"> (1) From the crankcase remove the bolt fastening the main bearing cover. 6φ × 30 mm bolt: 8 pcs. (2) Remove the cover, lightly tapping the cover evenly with a plastic hammer. 	<p>Sems bolt</p> <p>Be careful not to damage the oil seal.</p> <p>(See Fig. 19.)</p>	<p>10 mm box spanner</p>

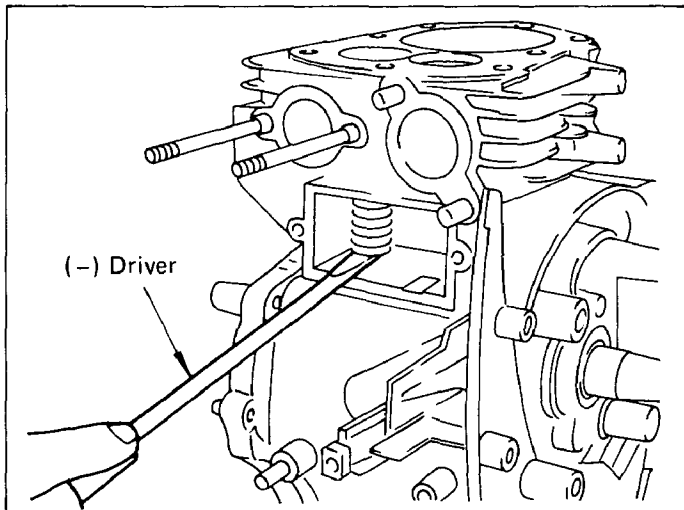

Fig. 18

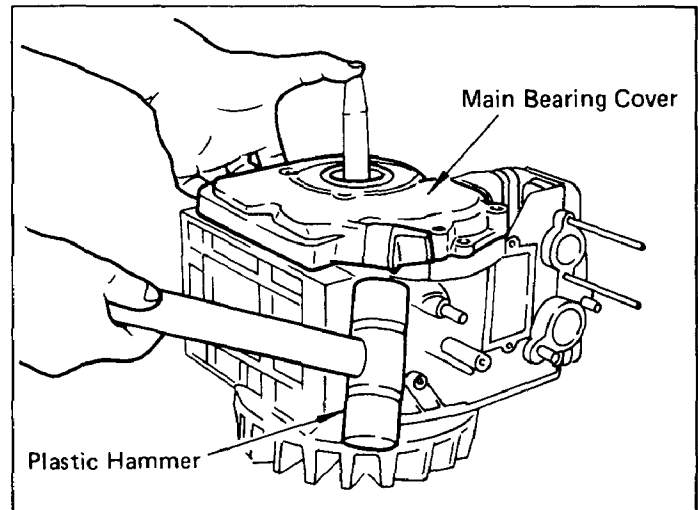

Fig. 19

Order	Item	Procedures	Remarks	Tool
16	Camshaft	(1) Remove the camshaft from the crankcase.	To prevent the tappets from falling or damaging, place the crankcase on the side. (See Fig. 20.)	
17	Tappet	(1) Remove the tappets from the crankcase.	Before removing put a mark of intake or exhaust on each tappet.	

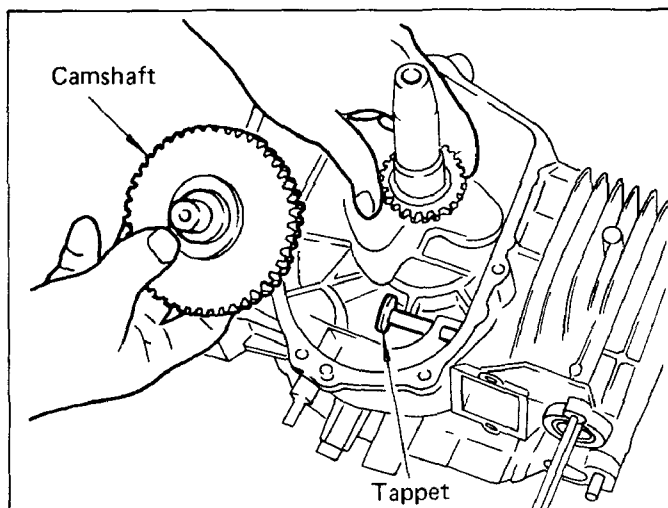

Fig. 20

Order	Item	Procedures	Remarks	Tool
18	Connecting rod and piston	<ol style="list-style-type: none"> (1) Scrape off carbon and other foreign deposits from the upper parts of the cylinder and piston, and then straighten out the bent tabs of the lock washers on the connecting rod, and remove two pieces of the bolt. (2) Remove the lock washers and connecting rod cap from the crankshaft. (3) Turn the crankshaft until the piston is raised up to the highest position, push the connecting rod up, and remove the piston out of the top of the cylinder. 		10 mm box spanner or 10 mm spanner
19	Piston and piston pin	<ol style="list-style-type: none"> (1) Remove the two clips, pull out the piston pin, and take the piston off from the small end of the connecting rod. (2) Spread the open ends of the piston rings and remove them from the piston. 	Be careful not to damage the inside of the small end of the connecting rod. Be careful not to break the rings by spreading too much.	
20	Crankshaft	<ol style="list-style-type: none"> (1) Remove the woodruff key (for the magneto). (2) Lightly hammer the magneto end of the crankshaft, and pull it out of the crankcase. 	Be careful not to damage the rings by spreading too much.	

5-4 HOW TO REASSEMBLE

● Precaution in reassembling

- 1) Every and each part should be cleaned thoroughly. Especially, pay utmost care and attention to the cleanliness of the piston, cylinder, crankshaft, connecting rod and bearings.
- 2) Scrape completely off carbons from the cylinder head and the upper part of the piston; especially the carbon adhered in the groove of the piston ring should be carefully and completely taken out.
- 3) Carefully check the lip portion of every oil seal. If faulty one is found, replace it without any hesitation. Apply enough oil to the lip portion of the oil seal when reassembling.
- 4) Replace all the gaskets with new ones.
- 5) Replace the key, pin, bolt, nuts, etc. with new one, if necessary.
- 6) Whenever tightening torque is specified, conform to the specified figures.
- 7) Apply oil to the revolutionary parts and friction surfaces, when reassembling.
- 8) Check and adjust the clearances of various portions and then reassemble.
- 9) When some main portions are assembled in the course of reassembling, turn or move the gadgets by hand and pay attention to the frictional noise and resistance.

● Sequence and precautions in reassembling

5-4-1 CRANKSHAFT

- 1) Fit the oil seal guide onto the end of the crankshaft, and insert the crankshaft into the crankcase as shown in Fig. 21.

Note: In case of not using the oil seal guide, be careful not to damage the oil seal lip.

- 2) Put woodruff key (for magneto) in place.

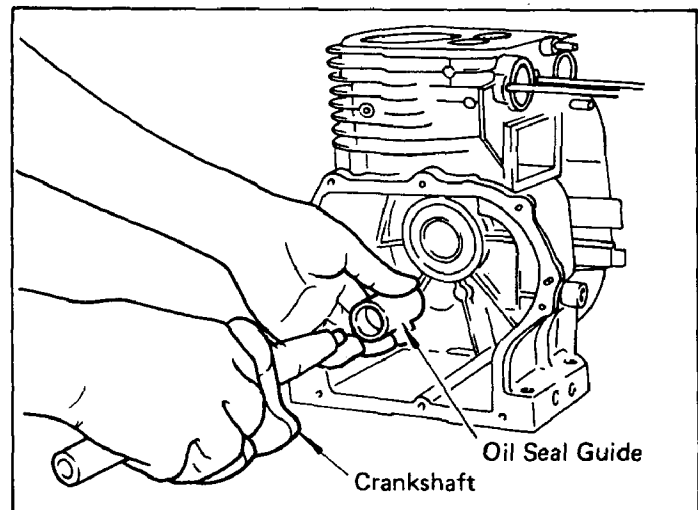
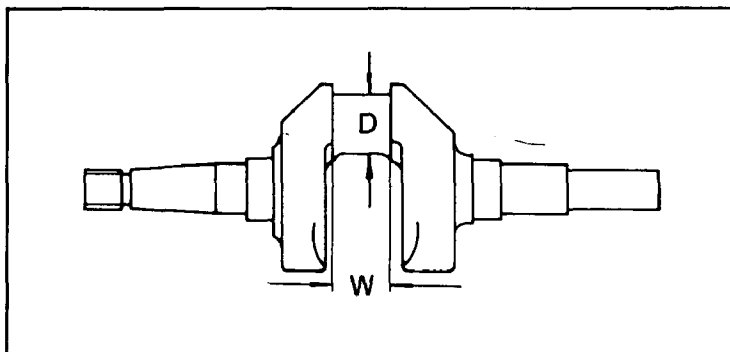

Fig. 21

3) Dimensions of Crankshaft Pin



		EY15V	EY20V
D (Crankshaft pin Dia.)		24 dia. $\begin{matrix} -0.037 \\ -0.050 \end{matrix}$	26 dia. $\begin{matrix} -0.037 \\ -0.050 \end{matrix}$
W (Crankshaft pin Width)		23 $\begin{matrix} +0.1 \\ 0 \end{matrix}$	24 $\begin{matrix} +0.1 \\ 0 \end{matrix}$
PISTON TO CYLINDER AT PISTON SKIRT THRUST FACE		0.020L ~ 0.059L	
PISTON RING GAP	TOP, SECOND	0.2L ~ 0.4L	0.05L ~ 0.25L
	OIL	0.2L ~ 0.4L	0.05L ~ 0.25L
PISTON RING SIDE CLEARANCE IN GROOVES	TOP RING	0.090L ~ 0.135L	0.050L ~ 0.095L
	SECOND RING	0.060L ~ 0.105L	0.010L ~ 0.055L
	OIL RING	0.010L ~ 0.065L	0.010L ~ 0.065L
CONNECTING ROD TO CRANK PIN	DIA	0.037L ~ 0.063L	
	SIDE	0.1L ~ 0.3L	
CONNECTING ROD TO PISTON		0.010L ~ 0.029L	
PISTON PIN TO PISTON		0.009T ~ 0.010L	

L: Loose, T: Tight

Fig. 22

5-4-2 PISTON and PISTON RING

- 1) If no ring expander is available, install the rings by placing the open ring ends over the first land of the piston and spreading the rings only far enough to slip them over the correct ring grooves.

Note: Pay attention not to break the rings by twisting. Install the oil ring first followed by the second ring and then top ring. Meantime, the surfaces of the second ring and the top ring with carved marks are to be faced up.

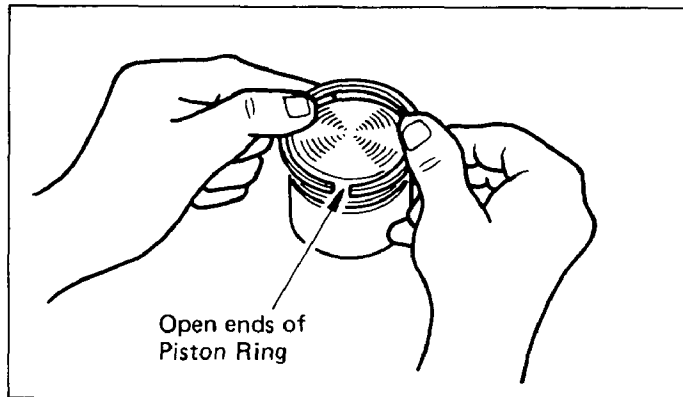

Fig. 23

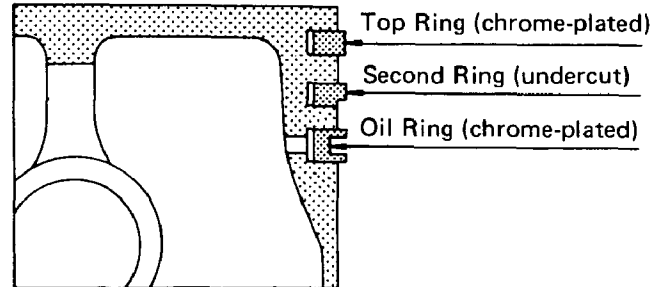



Fig. 24

- 2) Reassemble the piston and connecting rod by means of the piston pin.

Note: Apply enough oil to the small top end of the connecting rod. Be sure to place clips on both ends of the piston pin.

- 3) When installing the connecting rod into place, hold piston rings with the ring guide as shown in Fig. 25 (if no ring guide is available, keep pressing the piston ring with finger tips and gently strike the top of the piston with a wooden piece or the like to push it in), and check that the symbol  or mark MA on the connecting rod is in the direction of the flywheel magneto.

Note: Apply enough oil to the piston rings, connecting rod plain bearings and cylinder wall before reassembling.

Note: The open ends of the piston rings must be 90° apart from one another on the piston periphery.

Note: The clearance between the piston and cylinder must be measured at the piston skirt thrust surface.

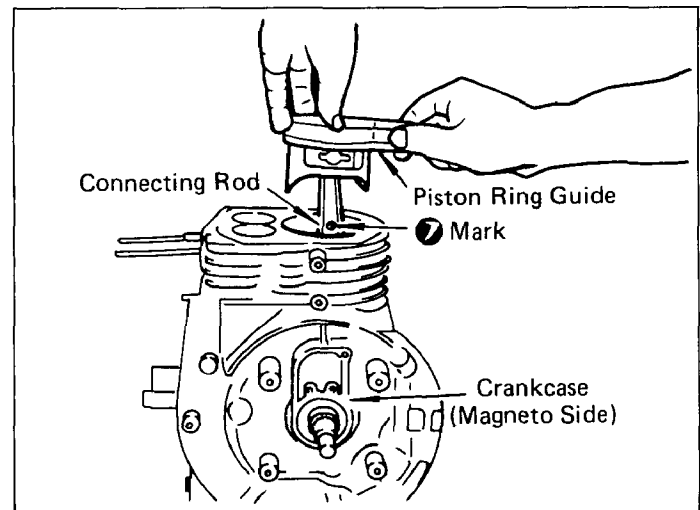

Fig. 25

5-4-3 CONNECTING ROD

- 1) Turn the crankshaft to the bottom dead center, lightly hammer the piston head until the connecting rod contacts the crankpin, and assemble.
- 2) When reassembling the connecting rod cap, match the alignment projection mark on the rod. (See Fig. 26.)

Note: Use new lock washers, and bend the tabs securely.

Note: After reassembly, confirm that the connecting rod moves lightly.

Note: Connecting rod cap tightening torque:

EY15V 90 ~ 115 kg-cm

EY20V 170 ~ 200 kg-cm

Note: For the piston, piston ring and rod clearance, see Fig. 22.

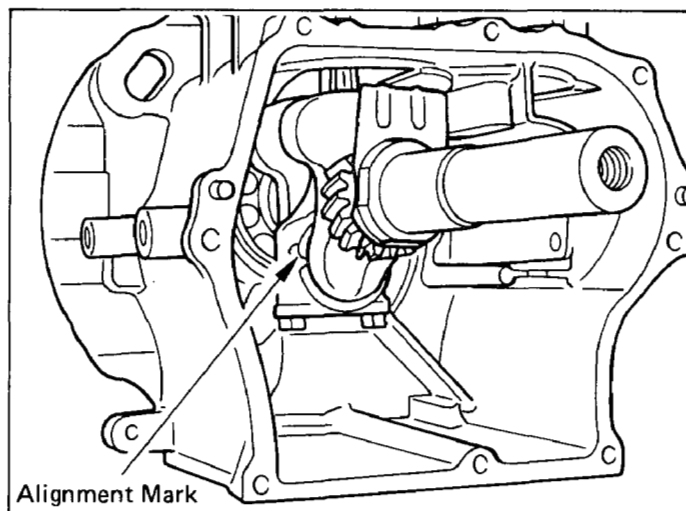

Fig. 26

5-4-4 TAPPET and CAMSHAFT

Insert the tappets back into their holes first, and then mount the camshaft.

Note: Align the timing mark at the root of a tooth of the cam gear with the one on the crank gear. If the valve timing is wrong, the engine cannot operate properly or at all. (See Fig. 27.)

Note: If the intake valve and exhaust valve were assembled contrarily each other, the tappet clearance cannot be kept correctly.

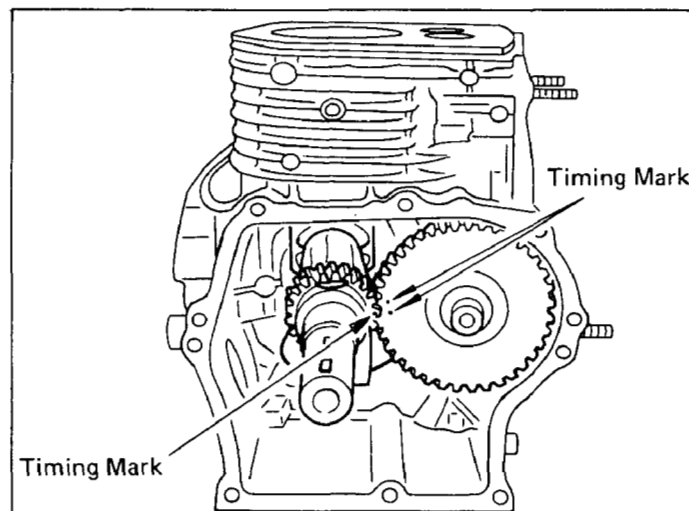

Fig. 27

5-4-5 MAIN BEARING COVER

Install the main bearing cover to the crankcase.

Note: As the governor gear is mounted on the main bearing cover side, install the main bearing cover while checking that it meshes with the teeth of the cam gear. (See Fig. 28.) Meantime, if the oil seal need be replaced, press-fit a new oil seal before installing the main bearing cover.

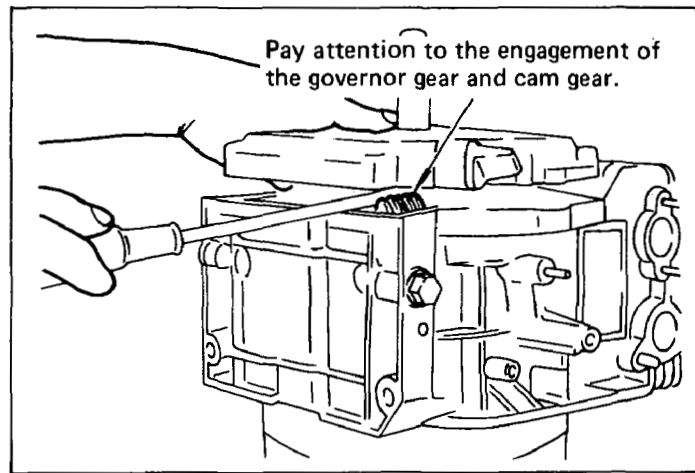

Fig. 28

Note: When installing main bearing cover, apply oil to the bearing and oil seal lip. Fit the oil seal guide over the crankshaft to protect the oil seal lip from damage. Then place the main bearing cover on.

Check the crankshaft if its side clearance is 0 ~ 0.2 mm; and if not, adjust it with the adjusting shim. (See Fig. 29.)

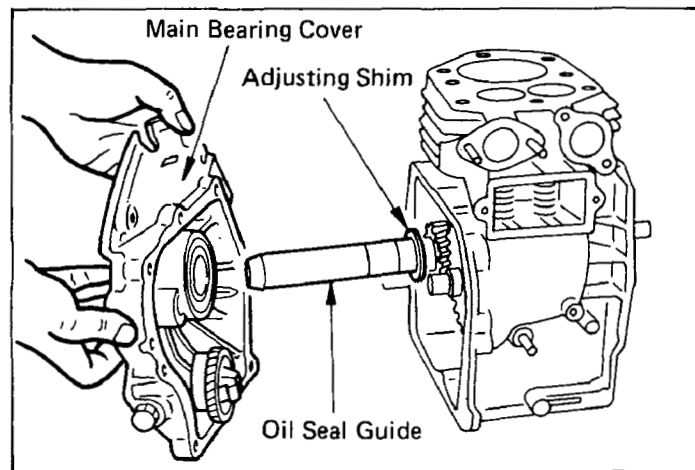

Fig. 29

*Note: Main bearing cover tightening torque:
80 ~ 100 kg-cm*

Note: Fig. 30 shows one of the methods measuring the crankshaft side clearance between the machined face of the crankcase and adjusting collar. As a paper packing is used on the machined face of the crankcase, adjust the clearance by taking this thickness of 0.22 mm into account. (See Fig. 30.)

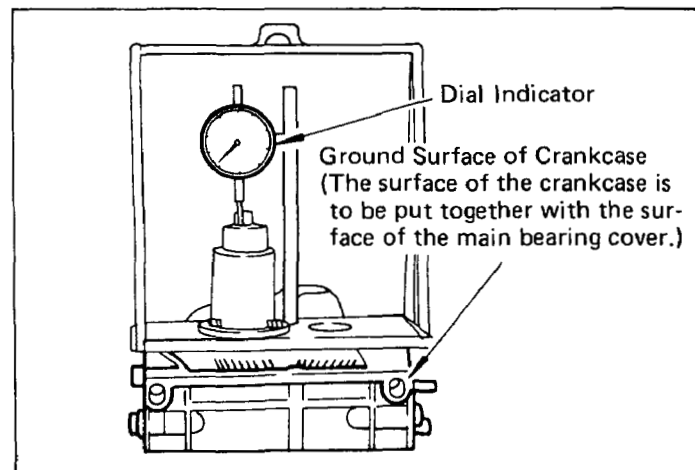

Fig. 30

5-4-6 INTAKE and EXHAUST VALVES

Remove carbon and gum deposits from the valves, valve seats, intake and exhaust ports and valve guides.

Note: If the valve face is dented or warped, replace the valves with new ones.

Note: If there is an excessive clearance between the valve guide and valve stem, replace the valve guide with a spare. For replacing, pull out the valve guide, using the valve guide puller and bolts as shown in Fig. 31, and press-fit a new valve guide into place.

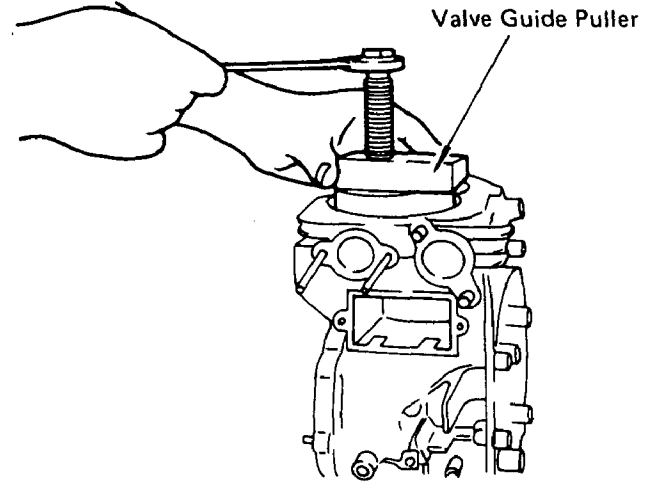
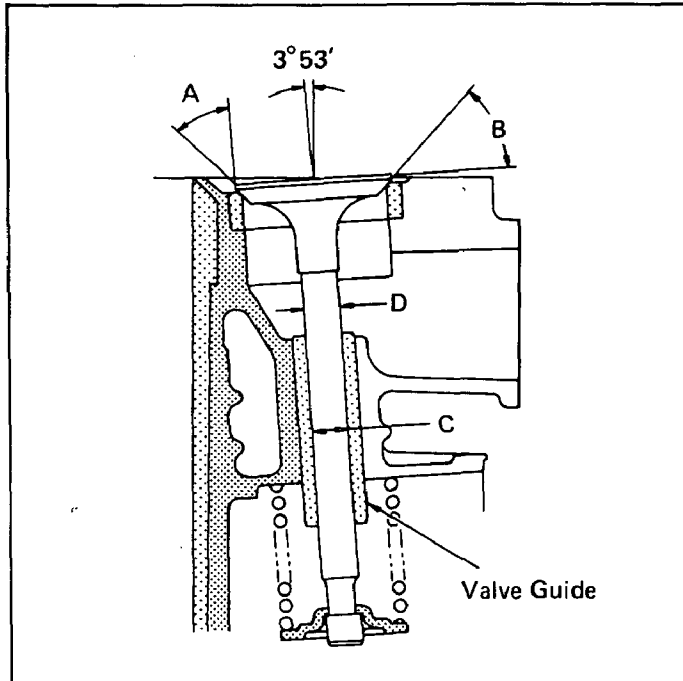

Fig. 31

VALVE and VALVE GUIDE CLEARANCE

		EY15V	EY20V
A—VALVE FACE ANGLE		45°	
B—SEAT ANGLE		45°	
C—GUIDE INSIDE DIA.		6.5 dia. $\begin{matrix} +0.022 \\ 0 \end{matrix}$	
D—VALVE STEM OUTSIDE DIA	INTAKE	6.5 dia. $\begin{matrix} -0.025 \\ -0.040 \end{matrix}$	
	EXHAUST	6.5 dia. $\begin{matrix} -0.056 \\ -0.078 \end{matrix}$	
MAXIMUM ALLOWABLE CLEARANCE BETWEEN C & D	INTAKE	0.025L ~ 0.062L	
	EXHAUST	0.056L ~ 0.100L	

L: LOOSE

Fig. 32

5-4-7 TAPPET ADJUSTMENT

Lower the tappet all the way down, push the valve, and insert a feeler gauge between the valve and tappet stem to measure the clearance. (See Fig. 33.)

Note: The correct tappet clearance for both intake and exhaust valve is 0.1 mm \pm 0.02 mm as measured when the engine is cold.

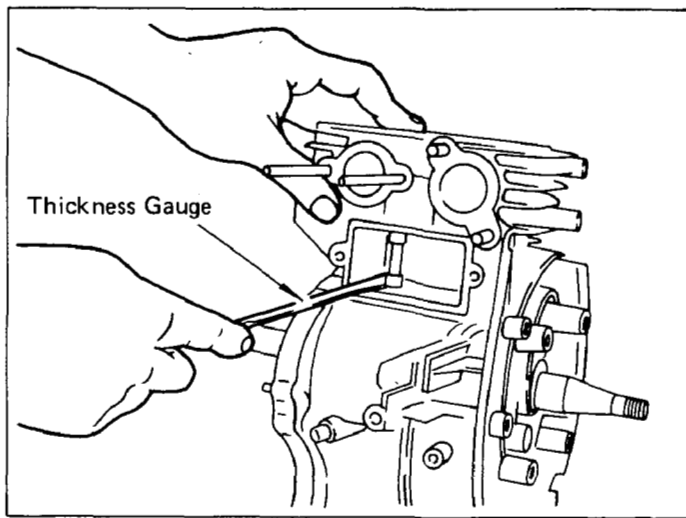

Fig. 33

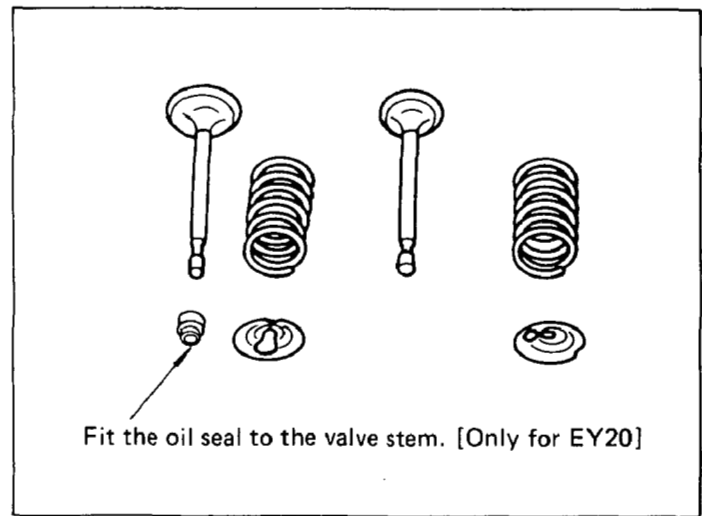

Fig. 34

Note: If the clearance is smaller than specified, slightly grind the top of the valve stem, and measure it again. On the contrary, if the clearance is too large, replace the valve with new one, and polish its contact surface with a compound to obtain a good fit. Then adjust the clearance.

Note: After the tappet clearance adjustment, install the valve spring retainers, and turn the crankshaft, and measure the tappet clearance once again if it is correct.

Note: [Only for EY20V] After the tappet clearance adjustment, fit the oil seal to the intake valve stem.

Note: INSTALLATION of SPRING RETAINERS

Place the notch on the outer circumference of the retainer toward this side and insert the retainer, like pushing in, using a special tool. (This special tool is used for EY18 and other models.) If a driver is used, insertion may be easier.

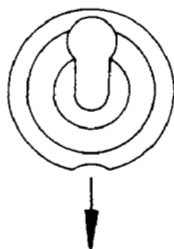

Front should be this side.

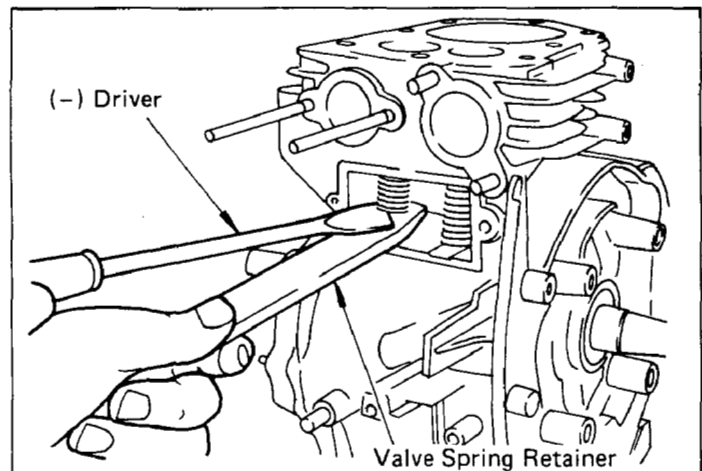

Fig. 35

5-4-8 CYLINDER HEAD

Remove carbon from the cylinder head, particularly its combustion chamber, and make clean the cooling fins. Also check the head for distortion.

Note: Replace the cylinder head gasket with a new one.

Note: DISTINCTION between the GASKET of EY15V and EY20V

The pitch of the holes for the bolts fastening cylinder head and the outer circumference dimensions of the gasket for EY15V and EY20V are same. However, the inner dimensions are different each other. The gasket for EY15V has a red mark while the gasket for EY20V has a green mark.

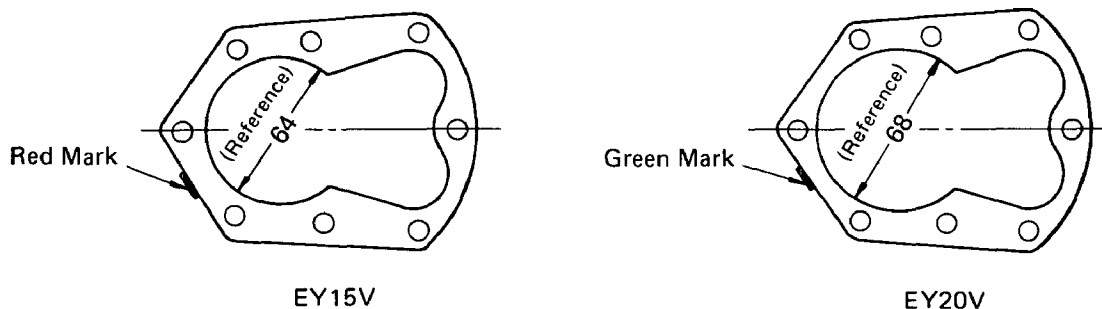

Fig. 36

Note: Cylinder head tightening torque: 220 ~ 260 kg-cm

Note: DISCRIMINATION of CYLINDER HEAD

As stated above, the pitch of the holes of cylinder head is common to both EY15V and EY20V. For enabling to discriminate the cylinder head of EY15V from that of EY20V, an embossed mark 15 is given to the former, while no embossed mark is given to the latter.

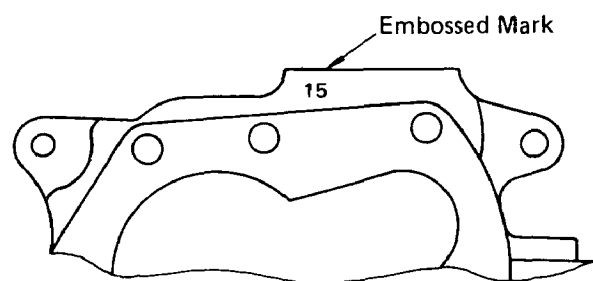

Fig. 37

5-4-9 IGNITION PLUG

Tightening torque of the ignition plug: 120 ~ 150 kg-cm

5-4-10 IGNITION COIL, FLYWHEEL and STARTER PULLEY

1) Temporarily fasten the ignition coil to the crankcase, and install the flywheel to the crankshaft. Starting pulley is fastened together with the flywheel.

Note: Before installing, wipe out oil from the crankshaft and the tapered portion of the flywheel.

Note: Flywheel tightening torque: 600 ~ 650 kg-cm

- 2) After measuring the air gap between the ignition coil and flywheel, retighten the ignition coil.
(See Fig. 38.)

Air gap: 0.5 mm

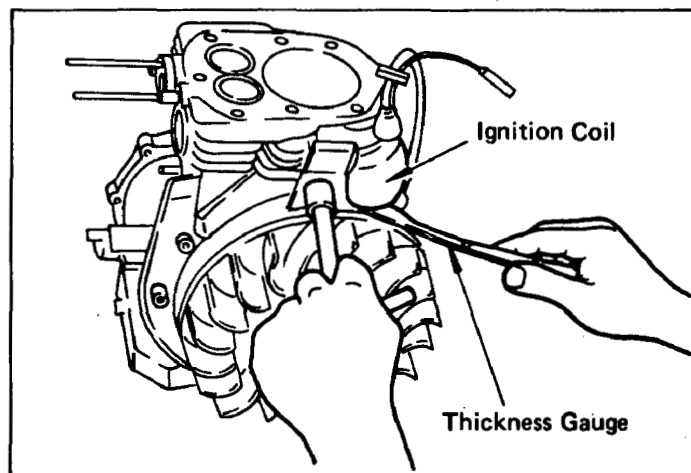

Fig. 38

5-4-11 FUEL TANK BRACKET

With four pieces of the bolt fasten the fuel tank bracket to the crankcase.

Note: *DISTICTION* between FUEL TANK BRACKET of EY15V and THAT of EY20V:

For enabling to discriminate the fuel tank bracket of EY20V from that of EY15V, an embossed mark 20 is given to the former, while no embossed mark is given to the latter.

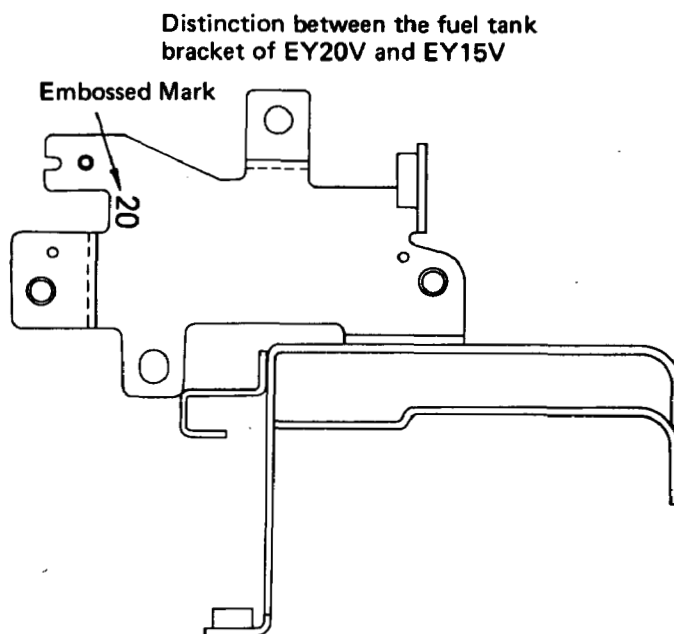

Fig. 39

5-4-12 INTAKE MANIFOLD

To the cylinder portion of the crankcase install the gasket and temporarily fasten the intake manifold. Then install in the order of the gasket, insulator, gasket and carburetor.

Note: *DISTINCTION* between INTAKE MANIFOLD of EY15V and THAT of EY20V:

For enabling to discriminate the intake manifold of EY20V from that of EY15V, an embossed mark 20 is given to the former, while no embossed mark is given to the latter.

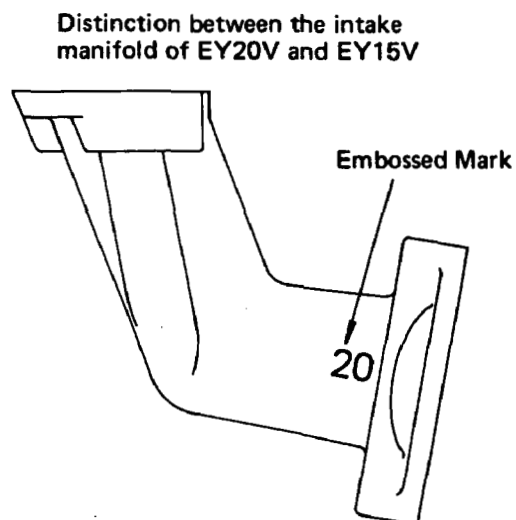

Fig. 40

5-4-13 CARBURETOR and ITS RELATIVE PARTS

- 1) Connect the carburetor throttle lever with the connecting link, and mount them onto the governor shaft.
- 2) Connect the speed control lever to the governor lever with the governor spring, and mount it onto the fuel tank bracket.
- 3) Connect the choke lever to the carburetor with the choke rod, and mount onto the fuel tank bracket.

5-4-14 AIR CLEANER

Mount the air cleaner to the intake manifold with two pieces of 6 mm nut and tighten the intake manifold mounting 6 mm nut. Then fasten air cleaner mounting 6 mm bolt to the fuel tank bracket.

5-4-15 FAN COVER and FUEL TANK

Intall the fan cover and fuel tank.

5-4-16 MUFFLER

With one piece of bolt fasten the muffler cover to the muffler and with two pieces of bolt fasten the muffler to the crankcase.

5-4-17 RECOIL STARTER

With 4 pices of $6\phi \times 8$ mm bolt fasten the recoil starter.

Note: It is feared that the bolt longer than 8 mm may damage the blades.

6. MAGNETO

6-1 MAGNETO

The spark for ignition is furnished by a magneto assembly. The magneto consists of a flywheel, ignition coil and contact breaker assembly (including condenser), of which flywheel is mounted on crankshaft and ignition coil contact breaker are mounted in crankcase directly. The EY20V type engine normally incorporates a solid state ignition system (T.I.C.) described in 6.5 "SOLID STATE IGNITION."

6-2 BREAKER POINT ADJUSTMENT (Fig. 41)

The breaker points, which are mounted in the crankcase inside the flywheel should be checked twice a season or whenever the ignition spark becomes weak. If there is an evidence of pitting or pyramidding, the breaker points must be corrected, and then it becomes necessary to readjust the gap to its proper clearance.

The normal breaker point opening (point gap) is 0.35 mm at full separation. Since the spark timing of 23° is regulated by the point opening, use a timing light to obtain an accurate spark advance. (Refer to "6-3 TIMING ADJUSTMENT.")

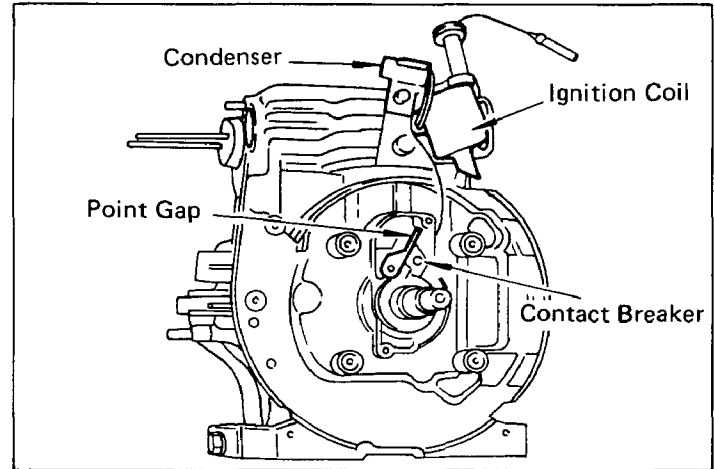

Fig. 41

To adjust breaker point opening, remove starting pulley, blower housing and flywheel from the engine and proceed as follows: (See Fig. 41.)

- 1) Remove the breaker cover from the contact breaker.
- 2) Turn the crankshaft over until the breaker arm comes in contact with the high point of the breaker cam. (Maximum point opening: 0.35 mm)
- 3) Loosen the contact support plate lock screw just enough so that breaker can be moved.
- 4) Insert a 0.35 mm feeler gauge between the points.

Caution: Adjust the breaker point gap without opening it more than 2 mm, otherwise rated heel-pressing force may not be obtained due to the bending of contact breaker arm.

- 5) Apply a screw driver to adjust tab and move the contact support plate just enough so that a slight drag is felt while sliding the feeler gauge from the gap between the points.
- 6) Tighten the lock screw and recheck the breaker point gap.
- 7) Pull a strip of 8 ~ 10 mm wide white paper through the closed points to remove oil and dust on the point surfaces.

Caution: When inserting a sheet of paper, never open the breaker point gap more than 2 mm.

- 8) Mount the flywheel, blower housing and starting pulley on the engine after adjustment.

6-3 TIMING ADJUSTMENT (See Figs. 42, 43 and 44.)

The spark is timed to occur at 23° before the piston reaches TDC on the compression stroke. This spark advance of 23° is controlled by the breaker point opening and this advance is obtained when the breaker point opening is adjusted according to the **BREAKER POINT ADJUSTMENT** to its proper point opening. However, the advance timing is more accurately adjusted through the following procedures using a timing tester as shown in Fig. 43.

Note: Refer to section "4-11 IGNITION" and "4-13 CHECKS and CORRECTIONS."

6-3-1 ALIGNMENT MARK for TIMING ADJUSTMENT (See Fig. 42.)

For timing adjustment, the following alignment marks are provided as shown in Fig. 42.

- * "M" mark and line on the crankcase
- * "P" mark and line on the flywheel cooling fan

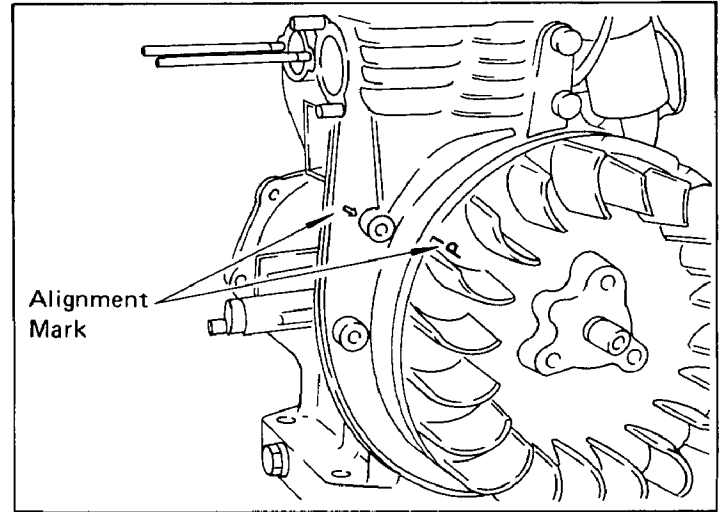

Fig. 42

6-3-2 TIMING ADJUSTMENT with TIMING TESTER

- 1) Disconnect the stop switch lead wires and the coil primary wire.
- 2) Remove the blower housing from the engine.
- 3) Connect the timing tester lead with red rubber cap to the coil primary wire and ground the lead with black rubber cap to the crankcase. (See Fig. 43.)

While the points are open, the buzzer within tester remains ringing and when the points are closed, the tester remains silent. (See Fig. 43.)

- 4) Turn the flywheel slowly until alignment mark on the flywheel is in the line with alignment mark on the crankcase.

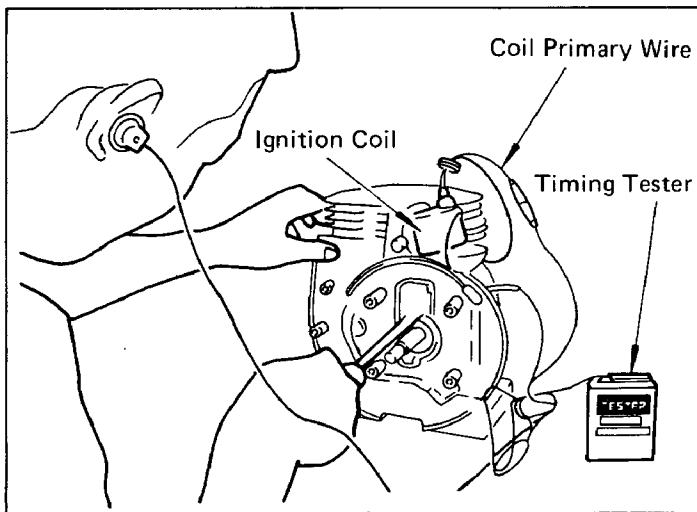

Fig. 43

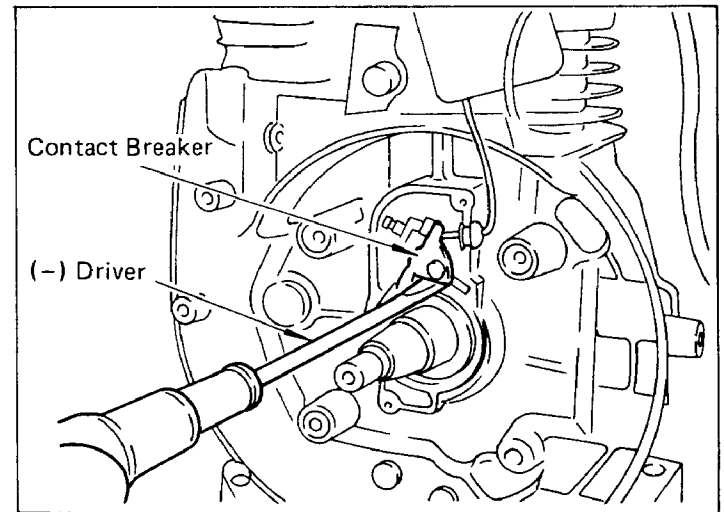

Fig. 44

- 5) Remove the flywheel without turning crankshaft at all.
- 6) Loosen the lock screw of the breaker point support plate so that the breaker point can be rotated.
- 7) By rotating the support plate of the breaker point, find the exact point when the buzzer within timing tester starts ringing from being silent. (See Figs. 43 and 44.)
- 8) Put the flywheel back and check by rotating flywheel slowly. If the buzzer in timing tester starts ringing when line mark on the flywheel is in the line with line mark on the crankcase. When the line marks are in alignment, the timing is correct.
- 9) If the timing mark lines are not in alignment, then readjust the point opening according to the **BREAKER POINT ADJUSTMENT**, by removing the flywheel and repeat the checking procedure 3) through 5).
- 10) After completing the timing adjustment remount the blower housing and connect the coil primary lead to the stop switch.

6-4 MAGNETO TROUBLESHOOTING

When the engine does not start or starts with difficulty, or when its operation is unstable, the following tests will clarify if they are caused by a defect in the magneto.

- 1) Check ignition cable for possible corrosion, broken, worn insulator or loose connection.
- 2) Check the sparking as described later in this section.
- 3) Check if the breaker points require cleaning, or adjusting or not. If the points are badly corroded or pitted, condenser may have to be replaced too.
Refer to "BREAKER POINT ADJUSTMENT."
- 4) If no spark takes place, replace ignition coil.

*SPARK TESTING

Remove spark plug from cylinder head and place it on blower housing, with the ignition cable connected to it.

Crank the engine several times by starting pulley and observe the spark in the spark gap of spark plug. If the spark is strong, the ignition system can be eliminated as the source of trouble.

If the spark is weak or there is no spark at all, repeat the checks according to the procedures 1) through 3) above.

The correct electrode gap is 0.6 ~ 0.7 mm. (Refer to section "13. CHECKS and CORRECTIONS.")

6-5 SOLID STATE IGNITION

The following solid state ignition systems are available as optional part of EY15V; and to EY20V engine these systems are equipped as standard parts.

T.I.C. (TRANSISTOR IGNITION CIRCUIT)

On the outside of the flywheel, an ignition coil is installed, which is so-called outer coil type. This is equipped to the standard type engine, and the excitor coil (primary-excitation) is available as an optional part. (The flywheel is for common use.) (See Fig. 52.)

7. GOVERNOR ADJUSTMENT

Model EY15V and EY20V employ a centrifugal flyweight type governor. The governor is mounted on the governor gear, and the throttle valve of the carburetor is automatically regulated by a lever which is connected to the governor in order to maintain constant engine speed against load variations.

The adjustment procedure of the governor is as follows: (See Fig. 45.)

- 1) Turn the speed control lever towards high speed, and confirm that the carburetor throttle valve is fully opened.

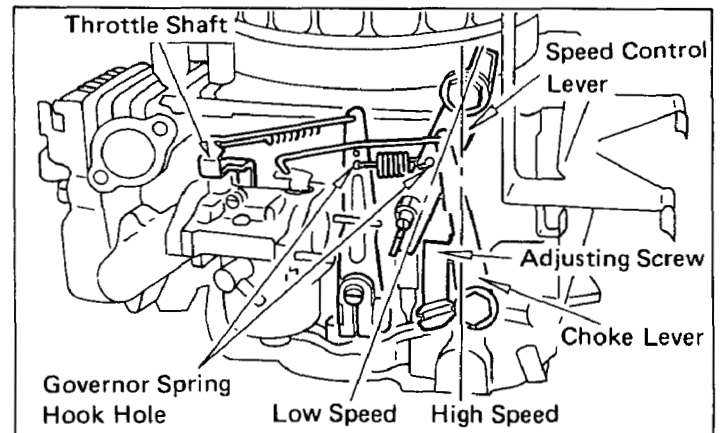
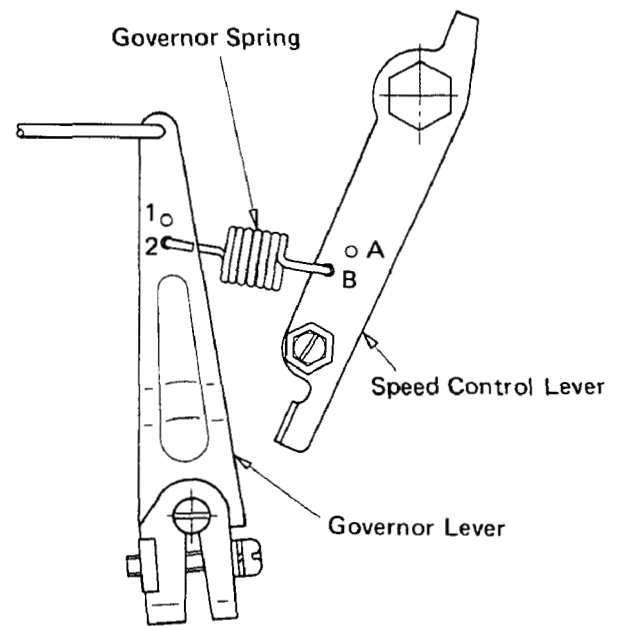

Fig. 45

- The point where the governor spring is to be hooked

For EY15V the governor spring is to be hooked at the points 2 ↔ A, while it is to be hooked at the points 2 ↔ B for EY20V. (See Fig. 46.)

Note: The governor lever for EY20V has an embossed mark 20, while the lever of EY15V has no mark on it.



Hooking Points
(Common to 3000, 3600 ~ 3800 rpm)

Fig. 46

The Dimensions of the governor spring to be hooked are different each other according to the engine revolution.

- Discrimination according to the dimensions:

EY15V, EY20V (3600 ~ 3800 rpm)

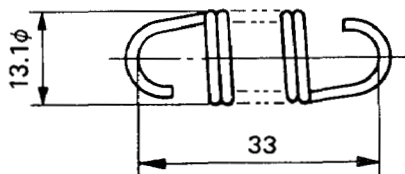

EY15V, EY20V (3000 rpm)

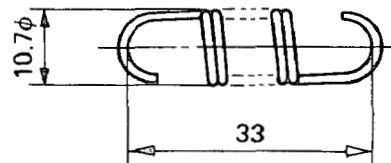

Fig. 47

- 2) With a screwdriver in the groove of the governor shaft, turn it "clockwise" fully until the governor shaft no longer moves, and then lock the governor lever to the governor shaft with the governor lever tightening bolt. (See Fig. 48.)

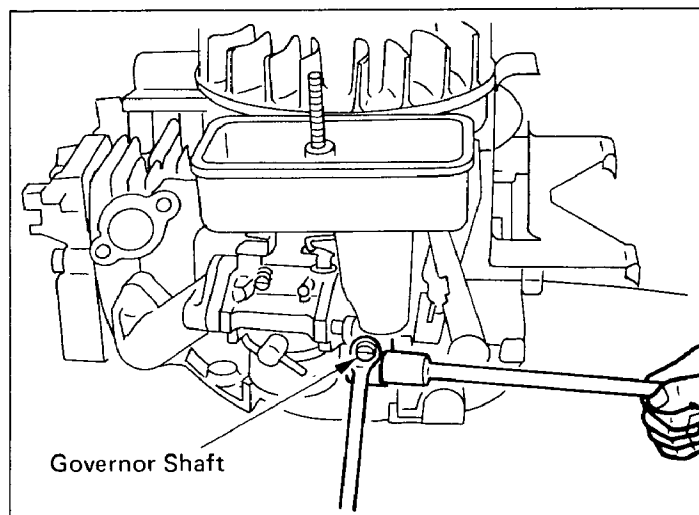

Fig. 48

8. CARBURETOR

8-1 OPERATION and CONSTRUCTION (See Figs. 49 and 50.)

8-1-1 FLOAT SYSTEM

The float chamber is located just below the carburetor body and, with a float and a needle valve, maintains a constant fuel level during engine operation.

The fuel flows from the fuel tank into the float chamber through needle valve. When the fuel rises to a specific level, the float rises; and when its buoyancy and fuel pressure are balanced, the needle valve closes to shut off the fuel, thereby keeping the fuel at the reference level.

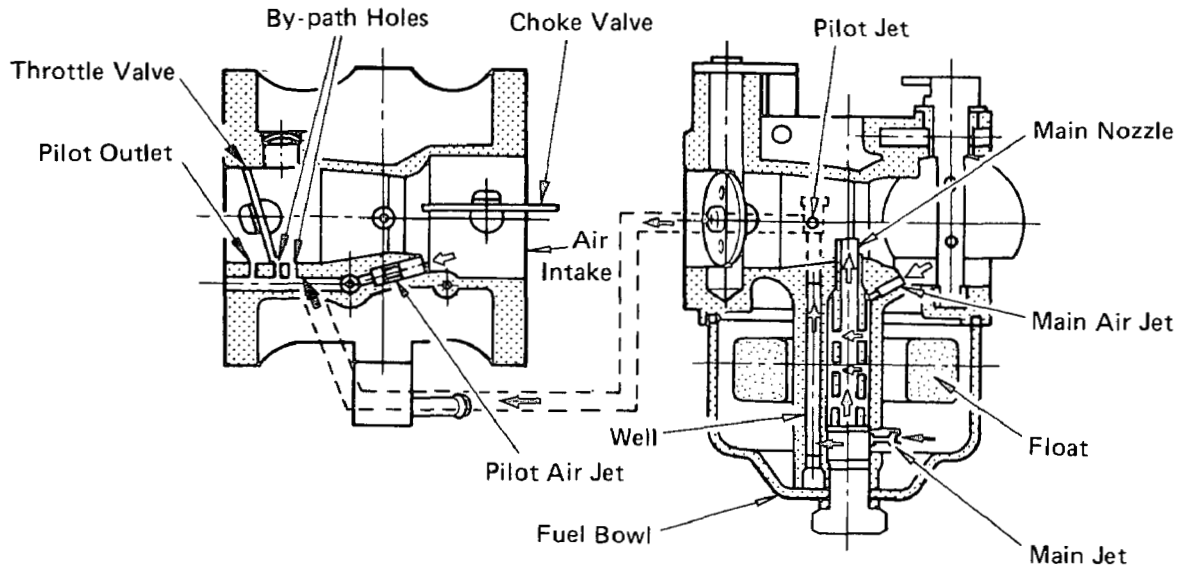

Fig. 49

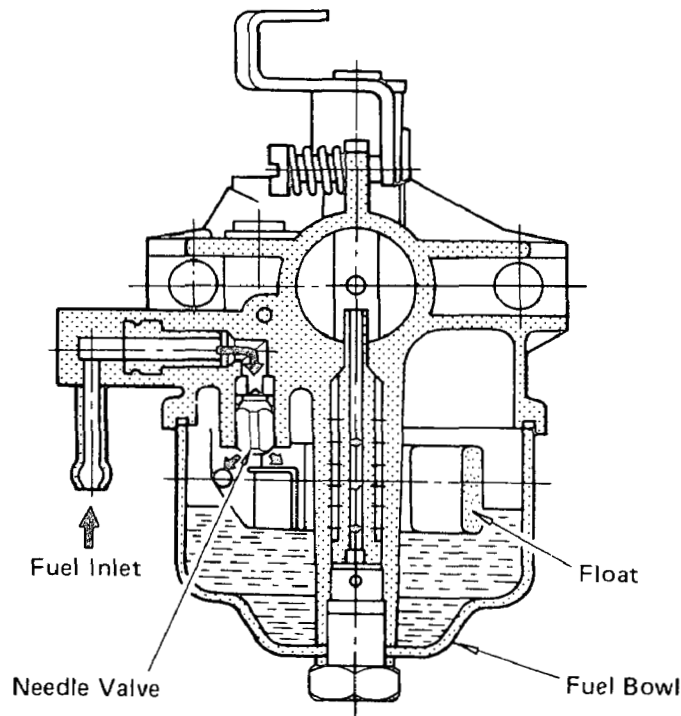

Fig 50

8-1-2 PILOT SYSTEM

The pilot system feeds the fuel to the engine during idling and low-speed operation.

The fuel is fed through the main jet to the pilot jet, where it is metered, and mixed with the air metered by the pilot air jet.

The fuel-air mixture is fed to the engine through the pilot outlet and the by-pass.

During engine idling, the fuel is mainly fed from the pilot outlet.

8-1-3 MAIN SYSTEM

The main system feeds the fuel to the engine during medium- and high-speed operation.

The fuel is metered by the main jet and fed to the main nozzle. The air metered by the main air jet is mixed with the fuel through the bleed holes in the main nozzle, and the mixture is atomized out of the main bore. It is mixed again with the air taken through the air cleaner into an optimum fuel-air mixture, which is supplied to the engine.

8-1-4 CHOKE

The choke is used for easy start in the cold season. When the recoil starter is pulled with a closed choke, the negative pressure applied to the main nozzle increases and draws much fuel accordingly; thus easily start up the engine.

8-2 DISASSEMBLY and REASSEMBLY

Apart from mechanical failures, most of carburetor troubles are caused by an incorrect mixing ratio, which may arise mainly due to a clogged up air or fuel passage in jets, or fuel level variations. In order to assure proper flow of air and fuel, the carburetor must be kept clean at all times. The carburetor disassembly and reassembly procedures are as follows: (See Fig. 51.)

8-2-1 THROTTLE SYSTEM

- 1) Remove the Philips screw (33) and throttle valve (28), and pull out the throttle shaft (29).
- 2) The spring (30) can be taken out by removing the throttle stop screw (31).

*Exercise care not to damage throttle valve ends.

8-2-2 CHOKE SYSTEM

- 1) Remove the Philips screw (22) and choke valve (23), and pull out the choke shaft (24).
- 2) When reassembling the choke shaft, make sure that the cutout in the choke valve faces the main air jet.

Meantime, when reassembling set the rings (26) and (27) at the right position.

8-2-3 PILOT SYSTEM

- 1) Remove the pilot jet (32), using correct tool to avoid damage to it.
- 2) Reassembly
Tighten the pilot jet securely. Otherwise, the fuel may leak, causing engine malfunction.

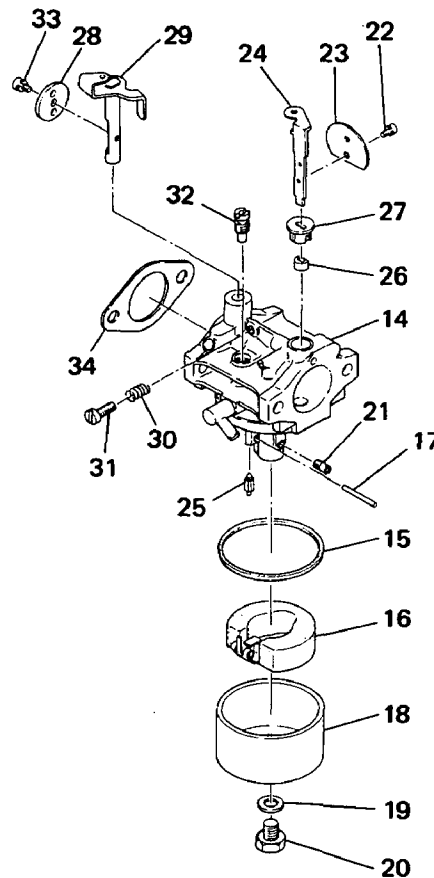

Fig. 51

8-2-4 MAIN SYSTEM

- 1) Remove the bolt (20) and take out float chamber body (18).
- 2) Remove the main jet (21) from the body (14)
- 3) Reassembly
 - a) Fasten the main jet securely to the body. Otherwise, the fuel may become too rich and cause engine malfunction.
 - b) The bolt tightening torque is 70 kg-cm.

8-2-5 FLOAT SYSTEM

- 1) Pull out the float pin (17) and remove the float (16) and needle valve (25). If the needle valve need be replaced, replace it with rubber needle.
Caution: When cleaning the jets, use neither a drill nor a wire (because of possible damage of the orifice which will adversely affect fuel flow). Be sure to use compressed air to blow them clean.
- 2) When removing the needle valve and flots, gently tap the reverse side using the rod more slender than the float pin and remove because the float pin is calked to the carburetor body.

9. BREAK-IN OPERATION of REASSEMBLED ENGINE

An overhauled engine must be operated at low speed break-in the parts. A thorough break-in is indispensable particularly when the cylinder, piston, piston rings or valves are replaced with new ones. The recommended break-in schedule is shown below.

LOAD		SPEED	TIME
EY15V	EY20V		
NO LOAD		2,500 rpm	10 minutes
NO LOAD		3,000 rpm	10 minutes
NO LOAD		3,600 rpm	10 minutes
1.35 HP	1.75 HP	3,600 rpm	30 minutes
2.7 HP	3.5 HP	3,600 rpm	60 minutes

10. ROBIN SOLID STATE IGNITION ENGINE

10-1 FEATURES

Model EY15V can employ as option a pointless igniton system, called Solid State Ignition, which is the circuit breaker type ignition device, utilizing the power transistor as an element for controlling electric current. This system is outer coil type without pulser and is called T.I.C. (Transistor ignition circuit type). To the EY20V this T.I.C. is equipped as standard parts.

Being different from the breaker point type ignition system, this brand-new system is completely free from such troubles as starting-up failure owing to dirty, burnt or oxidized point surface, lowering of ignition efficiency being caused by moisture, rough surface of breaker point and incorrect timing resultant from worn mechanical parts.

10-2 BASIC THEORY of T.I.C. (See Fig. 52.)

T.I.C. (Transistor ignition type) consists of the flywheel and ignition coil with built-in transistor; and its basic theory is as follows:

- 1) Revolution of the flywheel generates electricity on the primary side of the ignition coil, and the electric current **A** runs. **A** makes the power transistor "ON" and the electric current **B** passes.
- 2) The flywheel goes round further, and at the time of ignition the electric current **C** runs, then the electric current **D** runs to the signal transistor, by which the electric current **B**, passing through the power transistor, is abruptly cut; and as a result, the high voltage electricity is generated on the secondary side of the ignition coil and it sparks at the plug.

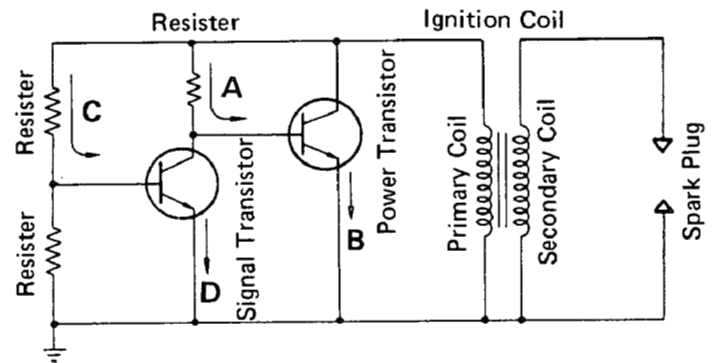

Fig. 52

11. TROUBLE-SHOOTING

The following three conditions must be satisfied for satisfactory engine start.

1. The cylinder filled with a proper fuel-air mixture.
2. An appropriate compression in the cylinder.
3. Good sparks at the correct time to ignite the mixture.

The engine cannot be started unless these three conditions are met. There are also other factors which make engine start difficult, e.g., a heavy load on the engine when it is about to start at low speed, and a high back pressure due to a long exhaust pipe, just to say a few.

The most common causes of engine troubles are given below.

11-1 STARTING DIFFICULTIES

11-1-1 FUEL SYSTEM

- 1) No gasoline in the fuel tank; or the fuel cock is closed.
- 2) The carburetor is not choked enough, particularly when the engine is cold.
- 3) Water, dust or gum in the gasoline block flow of the fuel to the carburetor.
- 4) Inferior grade gasoline or poor quality gasoline is not gasified enough to produce the correct fuel-air mixture.
- 5) The carburetor needle valve is held open by dirt or gum. This trouble can be detected as the fuel flows out of the carburetor when the engine is idling. (Overflow)
This trouble may be remedied, depending on cases, by lightly tapping the float chamber with the grip of a screwdriver or the like.
- 6) If the carburetor overflows, excessive fuel runs into the cylinder when starting the engine, making the fuel-air mixture too rich to burn. If this happens, remove the spark plug, and turn the starting pulley a few turns in order to let the rich fuel-air mixture out of the spark plug hole into the atmosphere. Keep the carburetor choke open during this operation. Dry the spark plug well, screw it into place, and try to start again.
- 7) When the engine is cold, pull the carburetor knob to let the gasoline flow into the carburetor.

11-1-2 COMPRESSION SYSTEM

If starting difficulties and loss of power are not due to the fuel system or ignition system, the followings must be checked for possible lack of compression.

- 1) Engine inside is completely dried up because of a long period of non-operation.
- 2) Loose or broken spark plug. This causes a hissing noise made by mixture gas running out of cylinder in compression stroke during cranking.
- 3) Damaged head gasket or loose cylinder head. A similar hissing noise is produced during compression stroke.
- 4) Incorrect Tappet Clearance

If the correct compression is not obtained even after remedying the above, disassemble the engine and check further as follows:

- a) Valve stuck open due to carbon or gum on the valve stem.
- b) If the piston rings are stuck on the piston, remove the piston and connecting rod from the engine, and clean, remedy or replace the parts.

11-1-3 ELECTRICAL SYSTEM

Check the followings for lack of sparks.

- 1) Leads of the ignition coil, spark plug or contact breaker disconnected.
- 2) Ignition coil damaged and shorted.
- 3) Spark plug cable wet or soaked with oil.
- 4) Spark plug dirty or wet.
- 5) Spark plug electrode gap incorrect.
- 6) Spark plug electrodes in contact with each other.
- 7) Contact breaker point pitted or fused.
- 8) Breaker arm stuck.
- 9) Condenser leaking or grounded.
- 10) Incorrect spark timing.

11-2 ENGINE MIFIRES.

- 1) Incorrect spark plug electrode gap. Adjust it to anywhere between 0.6 and 0.7 mm.
- 2) Ignition cable worn and leaking.
- 3) Sparks weak.
- 4) Ignition wire connections loose.
- 5) Pitted or worn breaker points.
- 6) Water in gasoline.
- 7) Insufficient compression.

11-3 ENGINE STOPS.

- 1) Fuel tank empty. Water, dirt, gum, etc. in gasoline.
- 2) Vapor lock, i. e., gasoline evaporating in the fuel lines due to overheat around the engine.
- 3) Vapor lock in the fuel lines or carburetor due to the use of too volatile winter gas in the hot season.
- 4) Air vent hole in the fuel tank cap plugged.
- 5) Bearing parts seized due to lack of oil.
- 6) Magneto or ignition coil faulty.

11-4 ENGINE OVERHEATS.

- 1) Crankcase oil level low. Add oil immediately.
- 2) Spark timing incorrect.
- 3) Low grade gasoline is used, or engine is overloaded.
- 4) Cooling air circulation restricted.
- 5) Cooling air path misdirected causes loss of cooling efficiency.
- 6) Cylinder head cooling fins clogged up with dirt.
- 7) Engine operated in an enclosed space without fresh supply of cooling air.
- 8) Exhaust gas discharge restricted, or carbon deposits in the combustion chamber.
- 9) Engine running on low-octane gasoline detonates due to heavy load at low speed.

11-5 ENGINE KNOCKS.

- 1) Low-quality gasoline.
- 2) Engine operating under heavy load at low speed.
- 3) Carbon or lead deposits in the cylinder head.
- 4) Spark timing incorrect.
- 5) Loose connecting rod bearing due to wear.
- 6) Loose piston pin due to wear.
- 7) Causes of engine overheat.

11-6 ENGINE BACKFIRES through CARBURETOR.

- 1) Water or dirt in gasoline, or low-grade gasoline.
- 2) Intake valve stuck.
- 3) Valves overheated, or red-hot carbon particles in the combustion chamber.
- 4) Engine cold.

12. INSTALLATION

Engine life, ease of maintenance and inspection, frequency of checks and repairs, and operating cost all depend on the way in which the engine is installed. Carefully observe the following instructions for installing the engine.

12-1 INSTALLING

When mounting the engine, carefully examine its position, the method of connecting it to a load (machine), the foundation, and the method of supporting the engine.

When determining its mounting position, in particular, make sure that gasoline and oil can easily be supplied and checked, the spark plug can easily be checked, the air cleaner can easily be serviced, and that the oil can easily be discharged.

12-2 VENTILATION

Fresh air is necessary for cooling the engine and burning the fuel.

In case where the engine is operated under a hood or in a small room, temperature rise in the engine room can cause vapor lock, oil deterioration, increased oil consumption, loss of power, piston seizure, shorter engine life, etc., making it impossible to operate the engine properly. It is necessary, therefore, to provide a duct or baffle to guide cooling air to the engine to prevent recirculation of the hot air used for engine cooling, and temperature rise of the load (machine).

Take steps as necessary to keep the engine room temperature below 50°C even in the hottest period of the year.

12-3 EXHAUST GAS DISCHARGE

Exhaust gas is noxious. When operating the engine indoors, be sure to discharge the exhaust gas outdoors. If a long exhaust pipe is used in such a case, the internal resistance increases causing loss of engine power. Thus pipe inside diameter must increase in proportion to exhaust pipe length.

Exhaust pipe: Less than 3 m long, pipe inside diameter 25 mm,
Less than 5 m long, pipe inside diameter 30 mm.

12-4 POWER TRANSMISSION to DRIVEN MACHINES

12-4-1 BELT DRIVE

Take the following notes into consideration.

- * V-belts are preferable to flat belts.
- * The driving shaft of the engine must be parallel to the driven shaft of the load.
- * The driving pulley of the engine must be in line with the driven pulley of the load.
- * Install the engine pulley as close to the engine as possible.
- * If possible, span the belt horizontally.
- * Disengage the load when starting the engine.

If no clutch is used, use a belt tension pulley or the like.

12-4-2 FLEXIBLE COUPLING

When using a flexible coupling, runout and misalignment between the driven shaft and engine shaft must be minimized. Runout and misalignment tolerance are specified by the coupling manufacturer.

12-5 WIRING

Wire as shown in the wiring diagram below.

[BREAKER POINT IGNITION TYPE]

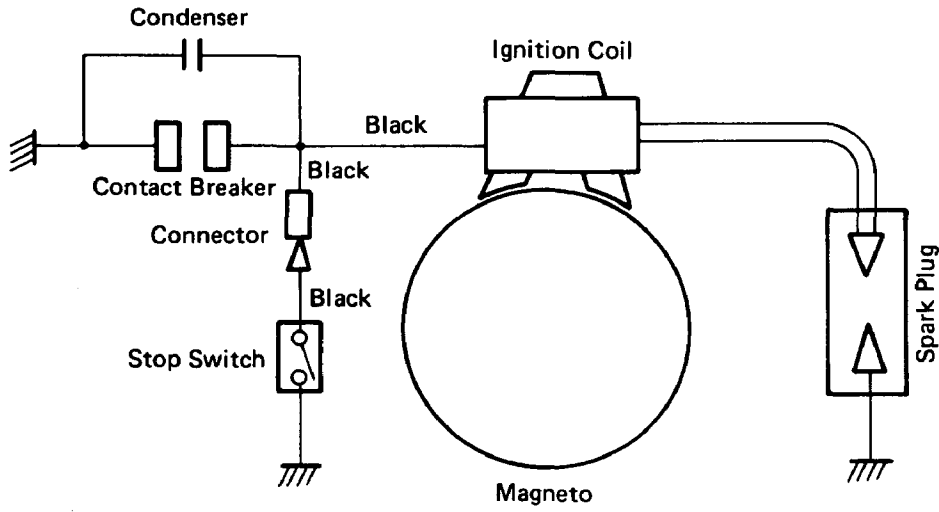

Fig. 53

[SOLID STATE IGNITION TYPE]

T.I.C. (Standard)

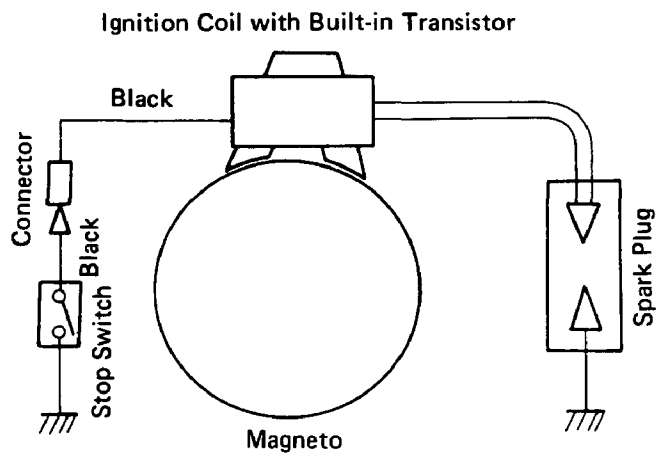

Fig. 54

13. CHECKS and CORRECTIONS

After disassembling and cleaning the engine, check and repair, if necessary, according to the correction table. The correction table applies whenever the engines are repaired. It is important for the servicemen to be familiar with the contents of this table. Correct maintenance is recommended by observing the correction standards specified.

The meanings of the terms used in the correction table are as follows:

- 1) **Correction**
Repair, adjustment or replacement of any engine parts.
- 2) **Correction Limit**
The limit on wear, damage or functional deterioration of engine parts beyond which normal engine performance cannot be expected without repairing such parts.
- 3) **Use Limit**
The limit beyond which parts can no longer be used in respect of performance or strength.
- 4) **Standard Dimensions**
The design dimensions of new parts minus tolerance.
- 5) **Correction Tolerance**
Tolerance on the dimensions of engine parts refinished or adjusted.

14. TABLE of CORRECTION STANDARDS

ITEM	ENGINE MODEL	STANDARD SIZE	CORRECTION		USE LIMIT	REMARKS	TOOL	CORRECTION METHOD	
			TOLERANCE	LIMIT					
Flatness of cylinder head	EY15 EY20	Less than 0.1	0.1	0.15			Surface plate, Feeler	Correct	
Cylinder	Bore	EY15	S.T.D. 63 dia.	Dif. between max. & min. +0.019 0	0.15	0.65	Cylinder gauge	Boring	
		EY20	67 dia.						
	Roundness	EY15 EY20		0.01					
	Cylindricity	EY15 EY20		0.015					
	Valve seat contact width	EY15 EY20		1.2~1.5	2.5				Correct
	Valve guide I.D.	EY15 EY20	6.5φ	+0.022 0	0.15	0.15			At middle portion
Piston	O.D. at skirt, in thrust direction (incl. over size) B 0.25 C 0.5	EY15	S.T.D. 62.98 dia. B 63.23 dia. C 63.48 dia.	0 -0.02	-0.1	-0.1	Micro-meter	Replace	
		EY20	S.T.D. 66.98 dia. B 67.23 dia. C 67.48 dia.						
	Width of ring groove	EY15 EY20	Top, 2nd 2	+0.025 0	0.15	0.15	Vernier calipers	Replace	
		EY15 EY20	Oil 2.8	+0.035 0					
	Piston pin hole	EY15 EY20	14 dia.	+0.002 -0.009	0.035	0.035	Cylinder gauge		
	Clearance between piston and cylinder	EY15 EY20		0.020~0.059	0.025	0.25	Max. cylinder dia. and piston dia. at skirt in thrust direction	Cylinder gauge, Micro-meter	Replace
	Clearance between piston ring and ring groove	EY15	Top 2nd Oil	0.090~0.135 0.060~0.105 0.010~0.065	0.15	0.15	Feeler gauge	Replace	
EY20		Top 2nd Oil	0.050~0.095 0.010~0.055 0.010~0.065						
Fit between piston and piston pin	EY15 EY20		-0.009~0.010	0.06L	0.06L	Cylinder gauge, Micro-meter			
Piston Ring	Ring gap	EY15	Top 2nd Oil	0.20 ~ 0.40	1.5	1.5	Feeler gauge	Replace	
		EY20	Top 2nd Oil						0.05 ~ 0.25
	Ring width	EY15	Top 2.0 2nd 2.0 Oil 2.8	-0.090~-0.110 -0.060~-0.080 -0.010~-0.030	-0.1	-0.1	Micro-meter	Replace	
EY20	Top 2.0 2nd 2.0 Oil 2.8	-0.050~-0.070 -0.010~-0.030 -0.010~-0.030							

ITEM	ENGINE MODEL	STANDARD SIZE	CORRECTION		USE LIMIT	REMARKS	TOOL	CORRECTION METHOD
			TOLERANCE	LIMIT				
Piston pin O.D.	EY15 EY20	14φ	0 ~ -0.008	-0.04	-0.04		Micro-meter	Replace
Connecting Rod	Large end I.D.	EY15	24 dia.	+0.013 0	0.1	0.1	Cylinder gauge	Replace
		EY20	26 dia.					
	Clearance between rod large end I.D. and crankpin	EY15 EY20		0.037~0.063	0.2	0.2	Cylinder gauge, Micro-meter	Replace
	Small end I.D.	EY15 EY20	14φ	0.010~0.021	0.08	0.08	Cylinder gauge	Replace
	Clearance between small end I.D. and piston pin	EY15 EY20		0.010~0.029	0.12	0.12	Cylinder gauge, Micro-meter	Replace
	Large end side clearance	EY15 EY20		0.1 ~ 0.3	1.0	1.0	Feeler gauge	Re-machine or Replace
	Parallelism between large end and small end bores	EY15 EY20		0.05	0.1	0.1	Test bar and Dial gauge	Re-machine or Replace
	Distance between large end and small end bores	EY15	83	±0.1		0.15		
EY20		91						
Crankshaft	Crankpin O.D.	EY15	24 dia.	-0.037 -0.050	0.15	0.5	Micro-meter	Re-machine or Replace
		EY20	26 dia.					
	Crankpin O.D. roundness	EY15 EY20		Less than 0.005			Micro-meter	
	Crankpin O.D. cylindricity	EY15 EY20		Less than 0.005			Micro-meter	
	Crankpin O.D. parallelism	EY15 EY20		Less than 0.008			Dial gauge	
Crankshaft journal O.D.	EY15	Drive s. 25 dia.	-0.003 -0.012	-0.05	-0.05		Micro-meter	Replace
		Mag. s. 25 dia.						
	EY20	Drive s. 25 dia.						
		Mag. s. 25 dia.						
Camshaft	Cam lobe height	EY15	24.95	±0.1	-0.25	-0.25	Micro-meter	Replace
		EY20	28.8					
	Journal O.D.	EY15 EY20	Drive s. 15 dia. Mag. s. 15 dia.	-0.016~-0.027	-0.05	-0.05	Micro-meter	Replace

ITEM	ENGINE MODEL	STANDARD SIZE	CORRECTION		USE LIMIT	REMARKS	TOOL	CORRECTION METHOD	
			TOLERANCE	LIMIT					
Valve spring	Free length	EY15 EY20	37		-1.5		Vernier calipers	Replace	
	Squareness	EY15 EY20				1.0	For total length	Square	Replace
Intake & Exhaust Valves	Valve stem O.D.	EY15	Intake 6.5 dia. Exhaust 6.5 dia.	-0.025~-0.040 -0.056~-0.078	-0.15		Micro-meter	Replace	
		EY20	Intake 6.5 dia. Exhaust 6.5 dia.	-0.025~-0.040 -0.056~-0.078					
	Clearance between stem and guide	EY15	Intake Exhaust	0.025 ~ 0.062 0.056 ~ 0.100	0.3	0.3	At middle	Cylinder gauge	Replace
		EY20	Intake Exhaust	0.025 ~ 0.062 0.056 ~ 0.100					
	Tappet clearance	EY15 EY20		When cold 0.10 ± 0.02	below 0.05 above 0.25			Feeler gauge	Correct
	Clearance between groove and retainer	EY15 EY20		0.1 ~ 0.3	0.5	0.5		Feeler gauge	Replace
Stem end length	EY15	Intake 5.9 Exhaust 5.9		-1.0	-1.0		Vernier calipers	Replace	
	EY20	Intake 6.2 Exhaust 6.4							
Tappet	Total length	EY15	35.6	+0.06 ~ 0	-0.5	-0.5	Vernier calipers	Replace	
		EY20	41.7						
Clearance between stem and guide	EY15 EY20		0.013 ~ 0.037	0.2	0.2				
Electric Device	Spark plug	EY15 EY20	NGK BM4A						
	Spark gap	EY15 EY20		0.6 ~ 0.7	1		Feeler gauge	Adjust or replace	
	Spark timing	EY15 EY20	23° before T.D.C.	± 2°	± 5°		Timing tester	Adjust	
	Point opening	EY15 EY20	0.35	± 0.05	± 0.1		Contact breaker spanner	Adjust	

ITEM	MODEL	HP/rpm	CORRECTION LIMIT	REMARKS
Max. Output	EY15	3.5/3600	Below 110% of rated output	
	EY20	4.6/3600		
Continuous Rated Output	EY15	2.2/3000		
	EY20	3/3000		

ITEM	MODEL	liter/hr	CORRECTION PRECISENESS	CORRECTION PROCEDURE
Fuel Consumption	EY15	1.1	135% of the standard value and up	3600 rpm at continuous rated output
	EY20	1.2		

ITEM	MODEL	cc/hr	USE LIMIT cc/hr	REMARKS
Lubricant Consumption	EY15	10	50	
	EY20	15		

ITEM	MODEL	ℓ	REMARKS
Fixed quantity of Lubricant	EY15	0.56	
	EY20		

☆Use the SC or higher grade engine oil.

ITEM	MODEL	Comparison between oil viscosity and temperature	REMARKS
Specified Lubricant Quality	EY15	Single grade	When the peripheral temperature is below -20°C , use the oil of viscosity and quality fitted to the local conditions.
			When the peripheral temperature is more than 40°C , use the oil of viscosity and quality fitted to the local conditions.
	EY20	Multi-grade	The oil consumption is apt to increase, when used under high peripheral temperature, so it is necessary to check every day.

-20 -10 0 10 20 30 40°C

• If quality and quantity of the engine oil become lower or less, burning might be caused.

ITEM	MODEL	FREQUENCY OF OIL CHANGE
Oil Change	EY15 EY20	First time: Change oil after 20 hours operation. Second Time and Thereafter: Change oil every 50 hours operation.

ITEM	MODEL	kg/cm ² /rpm	CORRECTION LIMIT	TOOL	REMARKS
Cylinder pressure	EY15	5/400	70% of normal value and down	Pressure gauge	Reference value Crankshaft Rev.
	EY20	6/400			

ITEM	MODEL	rpm	TOOL	REMARKS
Min. accelerating revolution	EY15	1600	Tachometer	
	EY20			

	ITEM	MODEL	kg-cm	ft-lb	TOOL	REMARKS
Tightening Torque	Cylinder head bolts	EY15	220 ~ 260			Torque wrench
		EY20				
	Connecting rod bolts	EY15	90 ~ 115			Torque wrench
		EY20	170 ~ 200			
	Magneto clamp nuts	EY15 EY20	600 ~ 650			Torque wrench
Main bearing cover bolts	EY15 EY20	80 ~ 100			Torque wrench	
Spark plug	EY15 EY20	120 ~ 150			Torque wrench	

15. MAINTENANCE and STORING

The following maintenance jobs apply when the engine is operated correctly under normal conditions. The indicated maintenance intervals are by no means guarantees for maintenance free operations during these intervals.

For example, if the engine is operated in extremely dusty conditions, the air cleaner should be cleaned every day instead of every 50 hours.

15-1 DAILY CHECKS and MAINTENANCE

Checks and maintenance	Reasons for requiring them
Remove dust from whatever parts which accumulated dust.	The governor linkage is especially susceptible to dust.
Check external fuel leakage. If any, retighten or replace.	Not only wasteful but also dangerous
Check screw tightening. If any loose one is found, re-tighten.	Loose screws and nuts will result in vibration accidents.
Check oil level in crankcase and add up as necessary.	If the engine is operated without sufficient oil, it will fail.

15-2 EVERY 20 HOURS CHECKS and MAINTENANCE

Checks and maintenance	Reasons for requiring them
Change crankcase oil.	To remove run-in wear particles

15-3 EVERY 50 HOURS (10 DAYS) CHECKS and MAINTENANCE

Checks and maintenance	Reasons for requiring them
Change crankcase oil.	Contaminated oil accelerates wear.
Clean air cleaner.	Clogged air cleaner harms engine operation.
Check spark plug. If contaminated, wash in gasoline or polish with emery paper.	Output power is reduced and starting is made difficult.

15-4 EVERY 100 ~ 200 HOURS (MONTHLY) CHECKS and MAINTENANCE

Checks and maintenance	Reasons for requiring them
Clean fuel filter and fuel tank.	The engine will be out of order.
Clean contact breaker points.	The engine output drops.

15-5 EVERY 500 ~ 600 HOURS (SEMIANNUAL) CHECKS and MAINTENANCE

Checks and maintenance	Reasons for requiring them
Remove cylinder head and remove carbon deposit.	The engine will be out of order.
Disassemble and clean carburetor.	

15-6 EVERY 1000 HOURS (YEARLY) CHECKS and MAINTENANCE

Checks and maintenance	Reasons for requiring them
Perform overhauls, clean, correct or replace parts.	The engine output drops and become out of order.
Change piston rings.	
Replace fuel pipe once a year.	To prevent from danger caused by the fuel leakage.

15-7 PREPARATION for LONG ABEYANCE

- 1) Perform the above 15-1 and 15-2 maintenance jobs.
- 2) Drain fuel from the fuel tank and carburetor float chamber.
- 3) To prevent rust in the cylinder bore, apply oil through the spark plug hole and turn the crankshaft several turns by hand. Reinstall the plug.
- 4) Turn the starting pulley by hand and leave it where the resistance is the heaviest.
- 5) Clean the engine outside with oiled cloth.
- 6) Put a vinyl or other cover over the engine and store the engine in dry place.











Robin America, Inc.

940 Lively Blvd., Wood Dale, IL 60191 • Tel: (708) 350-8200 • Fax: (708) 350-8212

Free Manuals Download Website

<http://myh66.com>

<http://usermanuals.us>

<http://www.somanuals.com>

<http://www.4manuals.cc>

<http://www.manual-lib.com>

<http://www.404manual.com>

<http://www.luxmanual.com>

<http://aubethermostatmanual.com>

Golf course search by state

<http://golfingnear.com>

Email search by domain

<http://emailbydomain.com>

Auto manuals search

<http://auto.somanuals.com>

TV manuals search

<http://tv.somanuals.com>