

Robin Industrial Engines®

SERVICE MANUAL

Models

EY33-2, EY44-2

1193S107



CONTENTS

<i>Section</i>	<i>Title</i>	<i>Page</i>
1.	SPECIFICATIONS	1
2.	PERFORMANCE	2
2-1.	Maximum output	2
2-2.	Continuous Rated Output	2
2-3.	Maximum Torque and Fuel Consumption Ratio at Max. Output	2
3.	FEATURES	3
4.	GENERAL DESCRIPTION of ENGINE CONSTRUCTION	4
4-1.	Sectional View of Engine	4
4-2.	Crankcase	6
4-3.	Main Bearing Cover	6
4-4.	Crankshaft	6
4-5.	Connecting Rod and Piston	6
4-6.	Camshaft	6
4-7.	Cylinder and Cylinder Head	6
4-8.	Valve Arrangement	6
4-9.	Balancer	6
4-10.	Governor	7
4-11.	Cooling	7
4-12.	Lubrication	7
4-13.	Ignition	7
4-14.	Carburetor	7
4-15.	Air Cleaner	7
4-16.	Selenium Rectifier	7
5.	INSTALLATION	8
5-1.	Mounting	8
5-2.	Ventilation	8
5-3.	Exhaust Gas Evacuation	8
5-4.	Fuel System	8
5-5.	Power Transmission to Driven Machines	8
5-6.	Wiring	9
6.	DISASSEMBLY and REASSEMBLY	10
6-1.	Preparations and Suggestions	10
6-2.	Special Tools	10
6-3.	Disassembly and Reassembly Procedures	11

7. MAGNETO	18
7-1. Magneto	18
7-2. Breaker Point Adjustment	18
7-3. Timing Adjustment	18
7-4. Magneto Service Instructions	19
8. GOVERNOR ADJUSTMENT	21
9. CARBURETOR	22
9-1. Operation and Construction	22
9-2. Disassembly and Reassembly	23
9-3. Adjustment	23
10. RUN-IN OPERATION OF ENGINE after REASSEMBLY	25
11. TROUBLE SHOOTING	26
11-1. Starting Difficultes	26
11-2. Engine Misses	27
11-3. Engine Stops	27
11-4. Engine Overheats	27
11-5. Engine Knocks	28
11-6. Engine Backfires Through Carburetor	28
12. CHECKS and CORRECTIONS	29
13. MAINTENANCE and STORING	35
13-1. Daily Checks and Maintenance	35
13-2. Every 20 Hours Checks and Maintenance	35
13-3. Every 50 Hours (10 days) Checks and Maintenance	35
13-4. Every 100~200 Hours (Monthly) Checks and Maintenance	35
13-5. Every 500~600 Hours (Semianual) Checks and Maintenance	36
13-6. Every 1000 Hours (Yearly) Checks and Maintenance	36
13-7. Preparation for Long Abeyance	36

Model		EY33-2				EY44-2			
		EY33-2D	EY33-2DS	EY33-2B	EY33-2BS	EY44-2D	EY44-2DS	EY44-2B	EY44-2BS
Type		Air-Cooled, 4-Cycle, Single-Cylinder, Horizontal P.T.O. shaft							
Bore x Stroke (in)		78mm x 68mm (3.07 x 2.68)				90mm x 68mm (3.54 x 2.68)			
Piston Displacement (cu.in)		325 cc (19.83)				433 cc (26.4)			
Compression Ratio		6.0							
Output	Continuous	6.5 HP/3,600 r.p.m.		6.5 HP/1,800 r.p.m.		8 HP/3,600 r.p.m.		8 HP/1,800 r.p.m.	
	Max.	8 HP/3,600 r.p.m.		8 HP/1,800 r.p.m.		10.5HP/3,600 r.p.m.		10.5HP/1,800 r.p.m.	
Max. Torque		1.7 kg-m/2,800 r.p.m.		3.4 kg-m/1,400 r.p.m.		2.3 kg-m/2,600 r.p.m.		4.6 kg-m/1,300 r.p.m.	
Direction of Rotation		Counter-clockwise, viewed from driving shaft side							
Cooling System		Forced Air Cooling							
Valve Arrangement		Side-Valve Type							
Lubrication		Splashing Type							
Lubricant		Mobile Oil SAE #20, #30 or 10W-30							
Carburetor		Horizontal Draft, Float Type							
Fuel		Automobile Gasoline							
Fuel Consumption Ratio		290 g/HP-h at 6.5 HP/3,600 r.p.m.		290 g/HP-h at 6.5 HP/1,800 r.p.m.		290 g/HP-h at 8 HP/3,600 r.p.m.		290 g/HP-h at 8 HP/1,800 r.p.m.	
Fuel Feed System		Gravity Type							
Fuel Tank Capacity		Approx. 7.5 liters (1.98 U.S.gal.)							
Speed Reduction		—————		1/2 Gear Type		—————		1/2 Gear Type	
Ignition System		Flywheel Magneto							
Spark Plug		NGK B-6HS							
Lighting Capacity		12V ~ 16V, 15W (Available if required)							
Starting Method		Rope Type	Electric Starter	Rope Type	Electric Starter	Rope Type	Electric Starter	Rope Type	Electric Starter
Dry Weight (lbs.)		38 kg (84)	43 kg (95)	38 kg (84)	43 kg (95)	41 kg (90)	46 kg (101)	41 kg (90)	46 kg (101)
Dimensions	Length (in)	378mm (14.88)				386mm (15.20)			
	Width (in)	432mm (17.01)	452mm (17.80)	432mm (17.01)	452mm (17.80)	463mm (18.23)	476mm (18.74)	463mm (18.23)	476mm (18.74)
	Height (in)	533mm (20.98)				544 mm (21.42)			

2. PERFORMANCE

2-1 MAXIMUM OUTPUT

The maximum output of an engine is such standard power as developed by that engine, after its initial run-in period with all the moving parts properly worn-in, when operating with the fully open throttle valve. Therefore, it follows that a new engine may not develop this maximum output in the beginning, because moving parts are not in a properly worn-in condition.

2-2 CONTINUOUS RATED OUTPUT

The continuous rated output of an engine is such power as developed by that engine when running at an optimum speed most favorable from the point of view of engine life and fuel consumption ratio. Therefore, it follows that when designing a driving system for any mechanism, with a model EY33-2 or EY44-2 engine, as a prime mover, the continuous power requirement of that mechanism must be kept below the continuous rated output specified.

2-3 MAXIMUM TORQUE AND FUEL CONSUMPTION RATIO AT MAX. OUTPUT

The maximum torque of an engine is that driving torque of the driving shaft at which the engine is driving an external load while the engine is developing its max. output. The fuel consumption ratio at max. output is that fuel consumption ratio of an engine while that engine is running at the max. output.

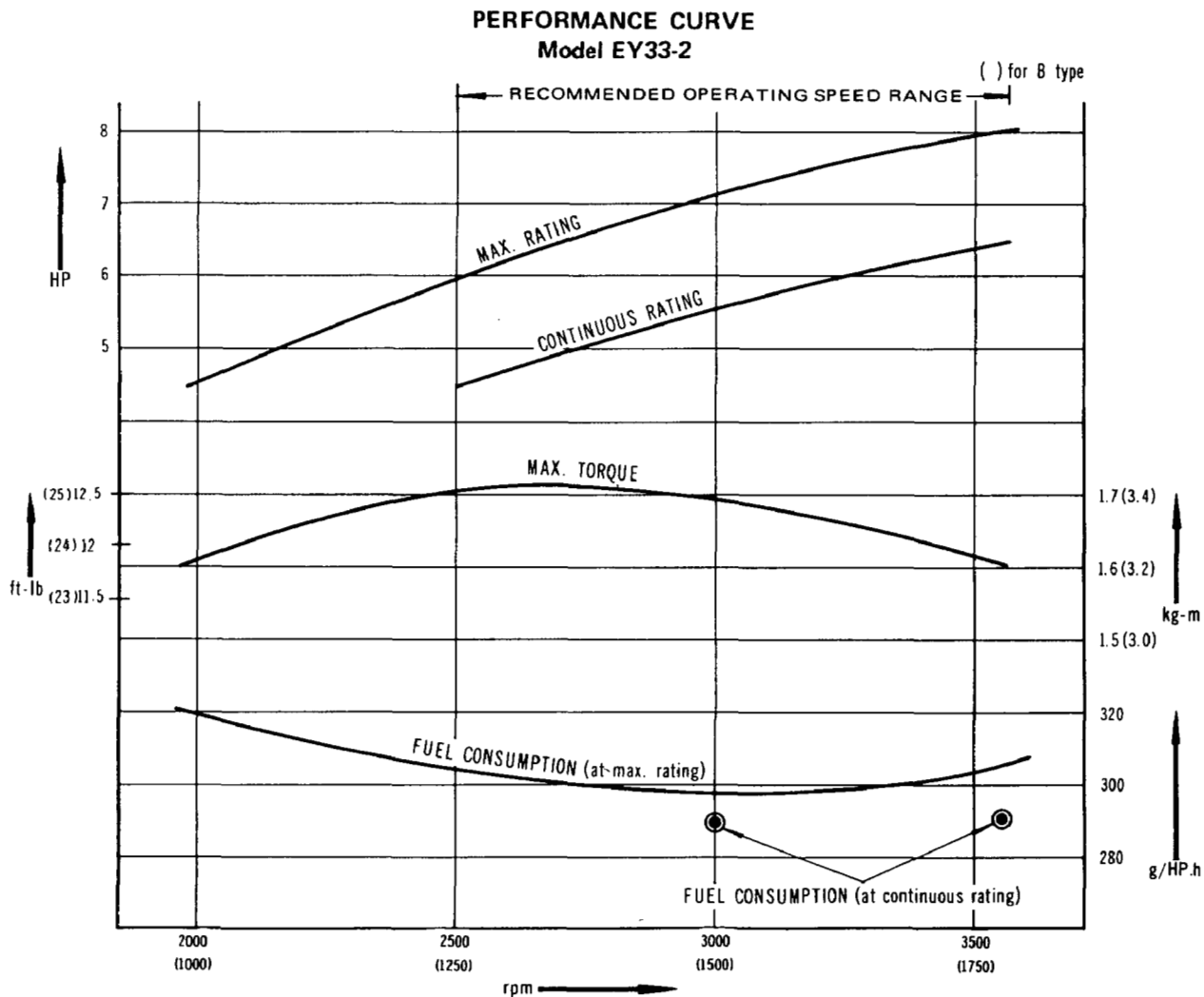

3. FEATURES

1. A compact, lightweight, and highly durable 4-cycle air-cooled EY-series with high output, embodying ingenious design and advanced machining techniques.
2. Simple construction, good appearance, plus easy start-up.
3. Smooth speed control functions of governor guarantees stable operation under various load conditions over a wide range of applications.
4. Economical advantage with minimized fuel consumption.
5. Since power can be taken in any direction simply by pulling the belt, and the feed and drain oil work can also be done easily in two directions of engine, the engine is easily coupled with operating machines.
6. The use of dynamic balancer reduces vibrations to such an extent as in a two-cylinder engine.

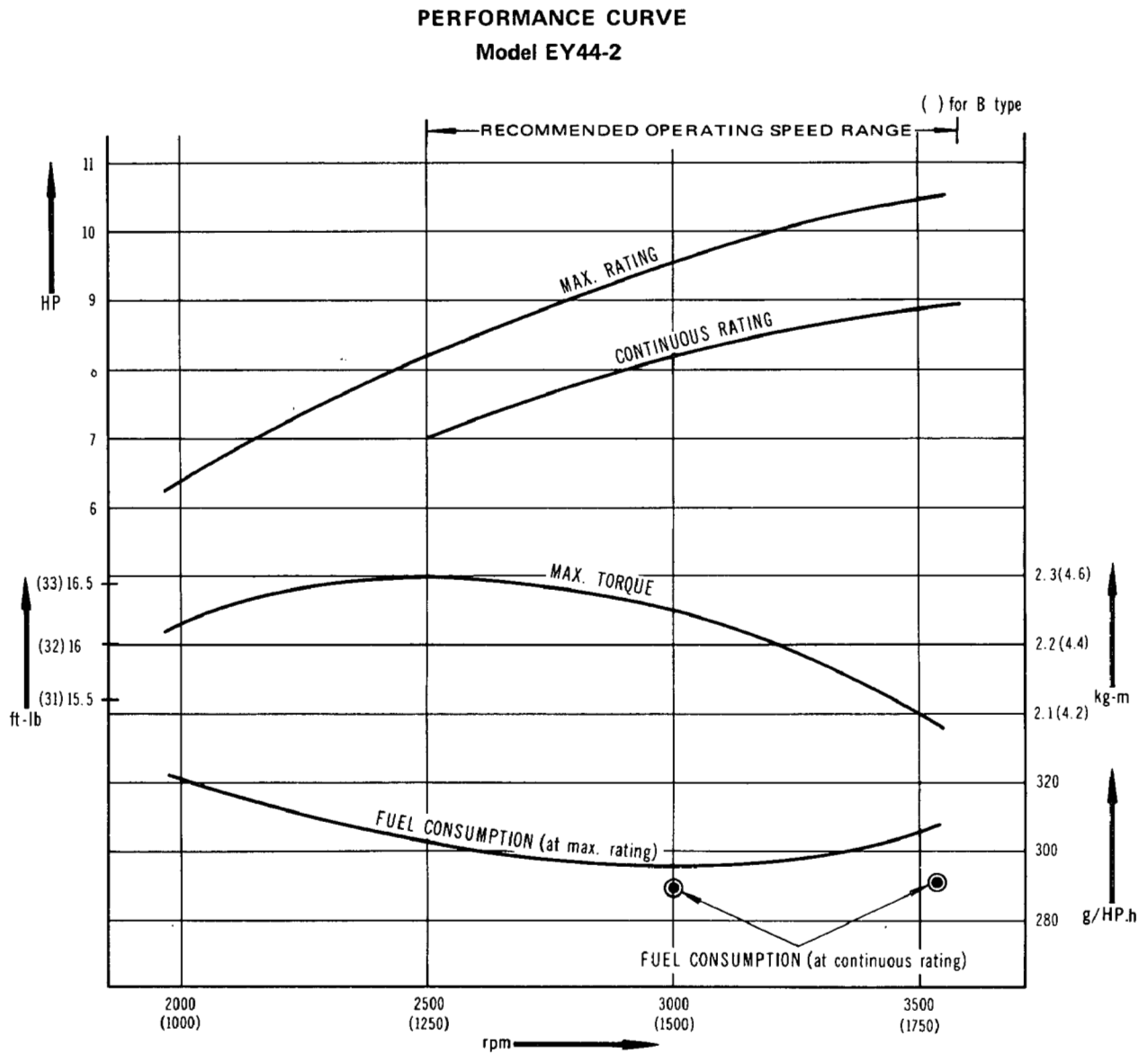

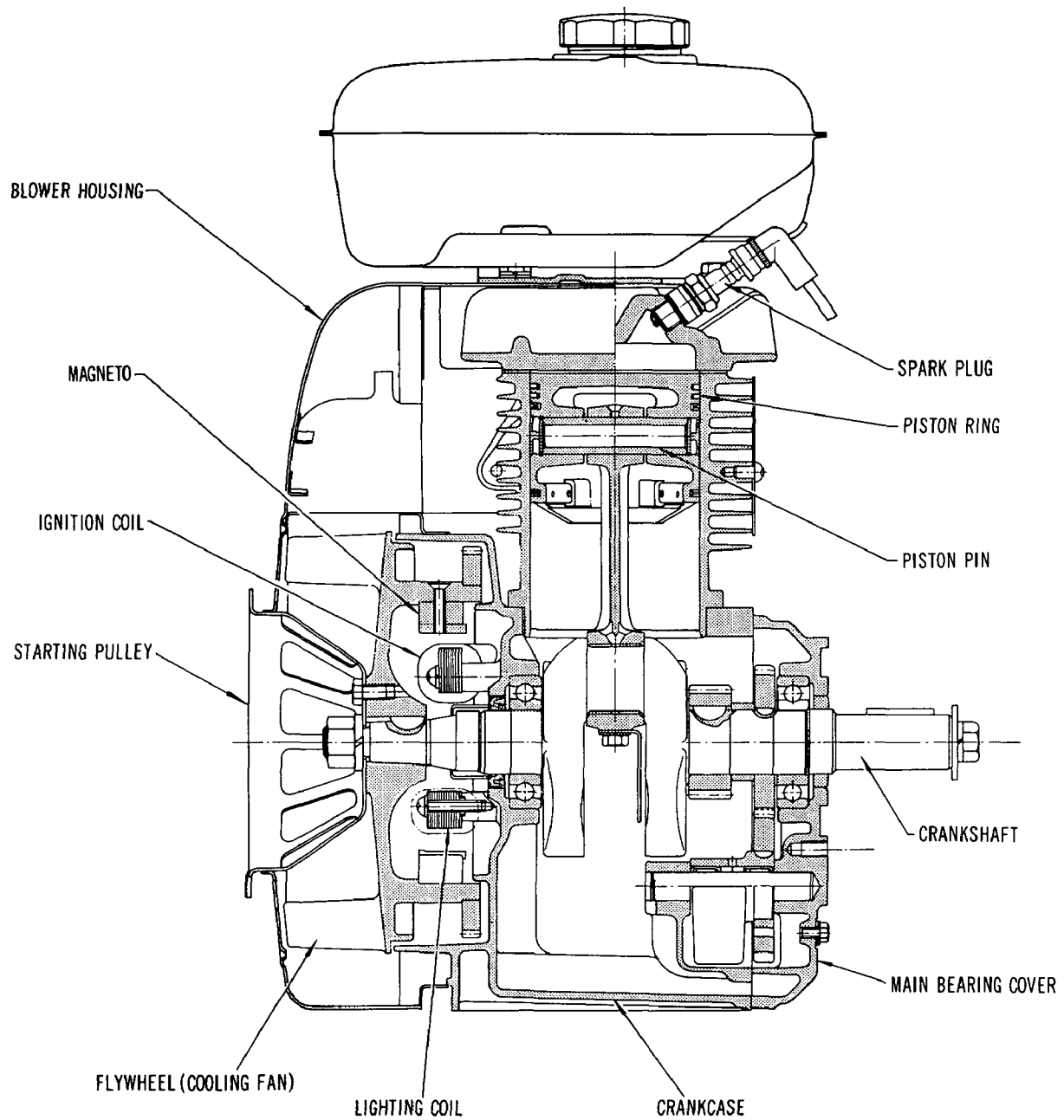

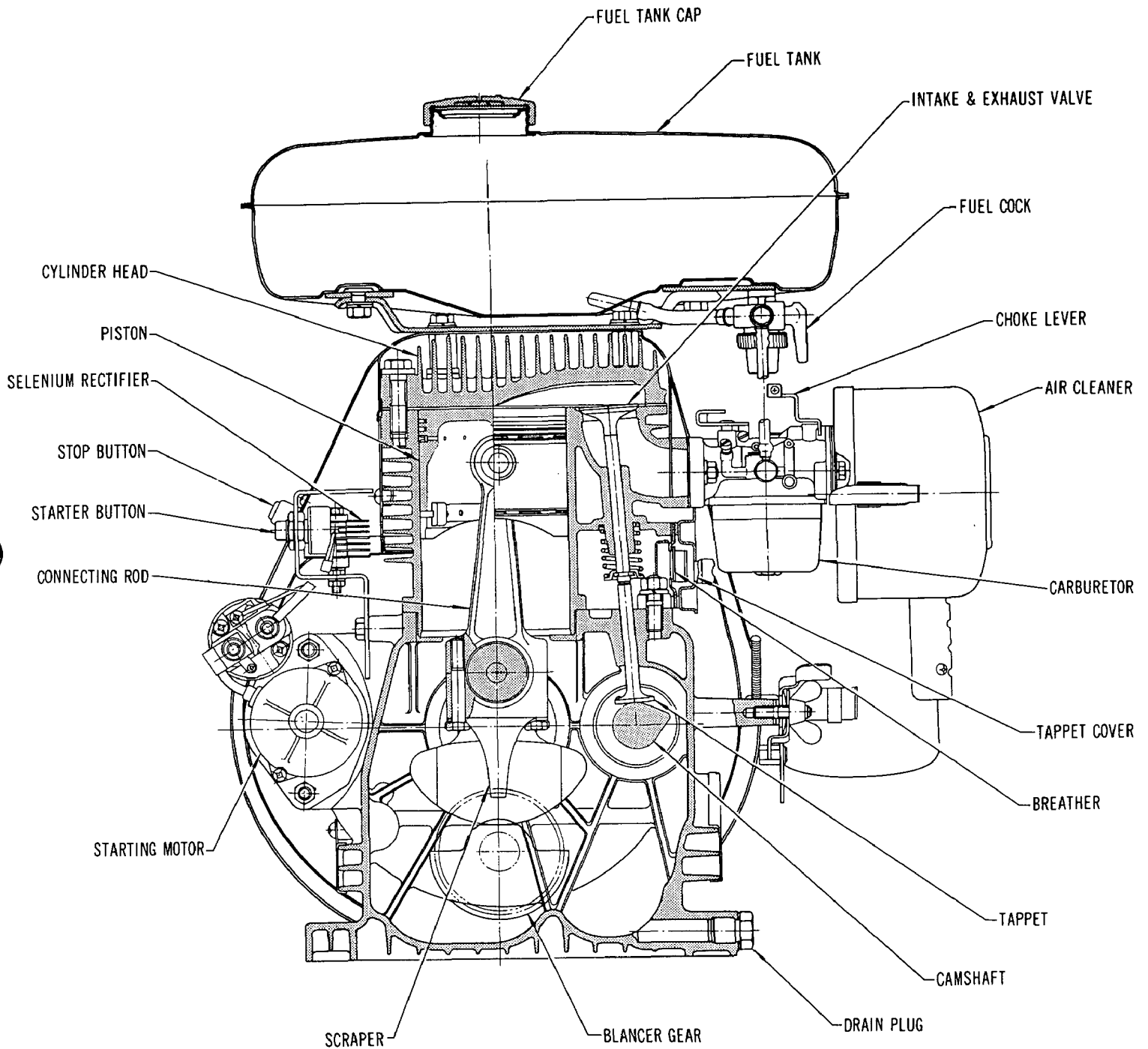

4-2 CRANKCASE

The crankcase is made of aluminum die-cast and separable on driving shaft side with main bearing cover assembled. Provided on blower side are two ball bearings, each supporting the crankshaft and camshaft.

4-3 MAIN BEARING COVER

The aluminum die-cast main bearing cover on the driving shaft side allows easy access to the engine interior for inspection simply by removing it. The flange and boss permit direct coupling of operating machines such as generators, pumps, etc. The oil inlets which also serve as oil gauges can be mounted on driving shaft side of Models EY33-2B and EY-44-2B. The force-fit balancer shaft and balancer holder mounting boss assure easy mounting of the balancer mechanism.

4-4 CRANKSHAFT

The crankshaft is machined from carbon steel forging with an induction hardened crank pin. The breaker cam is provided on blower side, while crankshaft gear and balancer gear are force-fit on driving side.

4-5 CONNECTING ROD and PISTON

The connecting rod is machined from aluminum alloy forging, and forged alloy itself serves as bearing metal at both ends. (Model EY44-2 employs aluminum metal on the large end.)

An oil scraper is provided on the large end for the purpose of splashing lubricating oil. The piston is machined from aluminum alloy casting and provided with grooves for two compression rings, one oil rings, and one skirt ring.

The EY44-2 piston has an offset structure at the piston pin center so as to reduce striking sound of piston.

4-6 CAMSHAFT

The carbon steel forging camshaft incorporates integral intake and exhaust cams plus a force-fit cam gear. The B-type camshaft also serves as driving shaft and it is driven at half the crankshaft speed.

4-7 CYLINDER and CYLINDER HEAD

The cylinder is made of special cast iron and provided with many fins for assuring excellent cooling effects. The cylinder head is made of aluminum alloy casting. The Ricardo type combustion chamber with a sufficient area assures high combustion efficiency. The spark plug is tilted to facilitate fuel tank mounting.

4-8 VALVE ARRANGEMENT

The exhaust valve is positioned in the upstream of the cooling air so that it is intensively cooled down for improved durability of engine.

4-9 BALANCER

An unbalanced inertia force produced due to crankshaft and piston connecting rod in the vertical and lateral directions balanced by balancer which rotates at a ratio of 1:1 in the direction opposite to crankshaft, so that vibrations due to unbalanced inertia force are reduced.

4-10 GOVERNOR

The centrifugal flyweight type governor assures constant-speed operation at selected speed, irrespective of load fluctuations.

4-11 COOLING

The cooling fan which also serves as a flywheel forcibly feeds cooling air to the cylinder head with the aid of cylinder baffles and head cover.

4-12 LUBRICATION

The rotating and sliding parts are lubricated by scooping and splashing oil in crankcase with oil scraper attached to connecting rod.

4-13 IGNITION

The ignition system is of flywheel magneto type with ignition timing set at 23° before TDC. The magneto is composed of a flywheel, an ignition coil, a breaker, and lighting (charging) coil. The flywheel (serving also as a fan) is mounted on crankcase, while the other elements are directly assembled in crankcase (For details, refer to the MAGNETO section).

4-14 CARBURETOR

A horizontal draft carburetor is employed. Its setting has been carefully after thorough tests to achieve best start-up, acceleration, fuel consumption, output, and other performance. For other details, see the CARBURETOR section.

4-15 AIR CLEANER

An impinge type semi-wet air cleaner catches dust particles in the air by means of felt in dust case. The air is then cleaned by passing through a filter element.

4-16 SELENIUM RECTIFIER

The selenium rectifier serves to rectify the AC current generated by AC charging coil of magneto into DC current to charge battery when a starting motor is combined.

5. INSTALLATION

Since the installation method affects the service life, ease of maintenance, frequency of check and repair, and operating costs of engine, the following contents should be carefully examined before installing your engine.

For details, refer to the separate "SALES MANUAL"—Engineering Information—.

5-1 MOUNTING

When installing the engine, its mounting position, coupling conditions with operating machines, and anchoring or supporting methods must be carefully examined. Particularly when determining its mounting position, due care should be taken to assure the convenience of such routines as replenishment and checking of fuel and oil, checking of spark plug and breaker points, maintenance of air cleaner, and oil drainage.

5-2 VENTILATION

The engine must be supplied with fresh air for cooling and fuel combustion. If engine is operated with a cover or in a small room, the engine room is heated, causing vapor lock, deterioration of oil, increase of oil consumption, power reduction, seizure, loss of engine life, and thus proper engine operation can be expected no longer.

It is therefore necessary to provide a cooling air duct and a baffle plate for the purpose of preventing insufficient circulation of heated air after cooling engine and or temperature-rise of operating machines.

The temperature of engine compartment should be kept below 40°C even in mid-summer.

5-3 EXHAUST GAS EVACUATION

Since the exhaust gas from engine is toxic, it must be exhausted outside if engine is operated indoors.

As the output power of an engine is considerably influenced by the length of exhaust duct, its diameter must be increased in proportion to its length.

5-4 FUEL SYSTEM

When fuel tank is separated from engine, it must be located so that its bottom surface lies within 5~50cm (2''~20'') above the fuel joint of carburetor. If the fuel tank is installed too low, fuel is not fed properly, and if it is too high, the carburetor may overflow.

For fuel piping, carefully examine it for heat conductivity, diameter, bending, and leakage through fittings so as to eliminate air lock and vapor lock.

It is recommended to minimize piping length. The standard ID of fuel pipe is 4~5mm ($\frac{5}{32}$ ''~ $\frac{13}{64}$ '').

5-5 POWER TRANSMISSION to DRIVEN MACHINES

5-5-1 BELT DRIVE

Be careful with the following items.

- *Use a V-belt rather than a flat belt.
- *Set the driving shaft of engine and the driven shaft of driven machine in parallel with each other.
- *Align the driving pulley of engine and the driven pulley of driven machine correctly with each other.
- *Mount the driving pulley as nearer to the engine as possible.

*Span the belt horizontally, if possible.

*Disconnect load from engine before starting it. Use a tension pulley or other means if a clutch is not available.

5-5-2 FLEXIBLE COUPLING

When a flexible coupling is employed, minimize runout and mis-alignment between driven shaft and engine driving shaft. For these tolerance, observe maker's instructions.

5-6 WIRING

- JIS CB104 female terminal
- ▶ JIS CA104 male terminal
- ⊙ JIS LA 104 or LA108 plate terminal
- - - - - The dotted parts are not supplied with the engine.

5-6-1 ROPE STARTING ENGINE

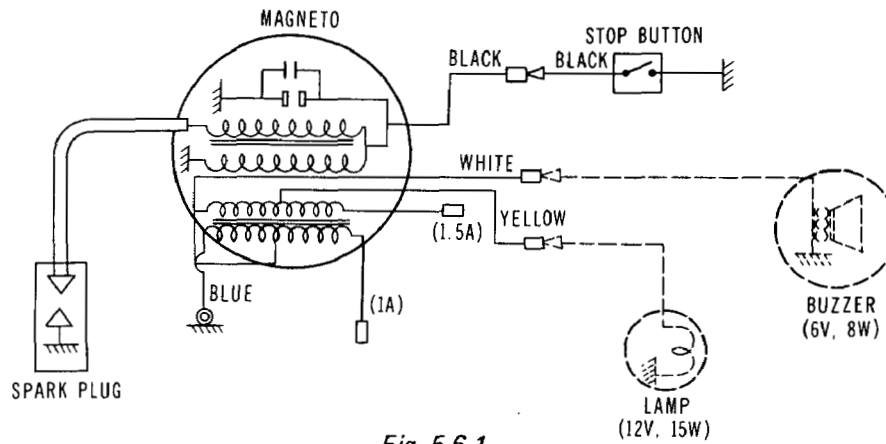

Fig. 5-6-1

5-6-2 ENGINE with STARTING MOTOR

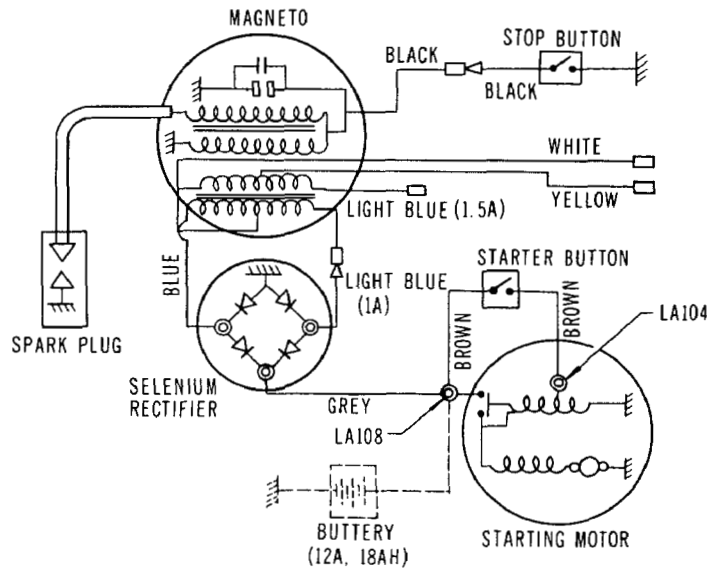

Fig. 5-6-2

6. DISASSEMBLY and REASSEMBLY

6-1 PREPARATIONS and SUGGESTIONS

- 1) When disassembling engine, carefully note mounting positions and methods of respective parts in order to be able to reassemble them correctly. Tag parts, if there is a possibility of confusion.
- 2) Prepare several boxes to keep parts belonging to respective groups together.
- 3) In order to prevent missing or misplacing, group related parts together, tentatively assembling them immediately after disassembling each sub-assembly.
- 4) Carefully handle parts, and clean them with washing oil after disassembling.
- 5) Use correct tools in correct ways.
- 6) Standard tools to be prepared for disassembling.
 - a) Work Bench
 - b) Washing Pan
 - c) Disassembling Tools
 - d) Washing Oil (Kerosene or Gasoline), Mobile Oil
 - e) Emery Paper, Cloth
- 7) Drain fuel and oil without fail before disassembly.

To drain oil, unscrew the oil drain plug located on the side of crankcase on carburetor side by turning it counter-clockwise.
- 8) Clamp cylinder head, cylinder main bearing cover, connecting rod, spark plug, and flywheel with specified torque when reassembling them.
- 9) Replace all the packings and gaskets with new ones when reassembling.
- 10) Wash parts with new gasoline or washing oil, and blow them with compressed air before reassembling.
- 11) Apply mobile oil to the rotating and sliding parts.
- 12) Be careful not to contaminate parts with dust during reassembling.
- 13) Tighten bolts, nuts, and screws to correct torque readings specified. If small screws are tightened too strongly, they may be broken.
- 14) After reassembling, turn the moving parts by hand, and check them for signs of abnormal friction, noises, or looseness.

6-2 SPECIAL TOOLS

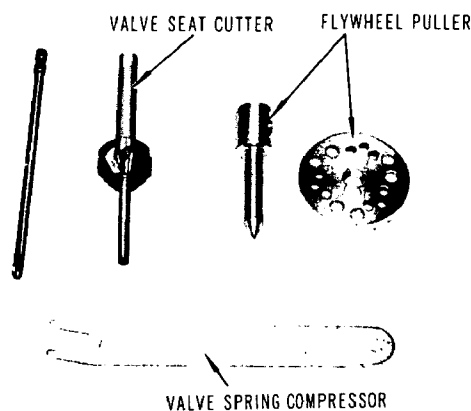

Fig. 6-2

Description	Part No.	Q'ty
Flywheel Puller	209 99010 07 (Y790-350)	1
Bolt	001 65085 00	3
Valve Spring Compressor	209 99011 07 (Y790-282)	1
Valve Seat Cutter (45°)	209 99012 07	1
Pilot Stem	(H640-118)	1

6-3 DISASSEMBLY and REASSEMBLY PROCEDURES

6-3-1 FUEL TANK and TANK BRACKET

- 1) Disconnect fuel pipe between fuel strainer and carburetor from carburetor.
- 2) Detach fuel tank from its mounting bracket (8mm nut × 4).
- 3) Detach bracket and head cover from cylinder head (8mm bolt × 2).

In reassembly;

It is recommended to replace fuel pipe with new one before reassembly.

CAUTION: REPLACE FULE PIPE WITH NEW ONE ONCE EVERY YEAR.

6-3-2 BLOWER HOUSING and CYLINDER BAFFLE

- 1) Disconnect primary coil wire from stop button wire.
- 2) Take off muffler cover and blower housing from crankcase, and baffle from cylinder head.
(6mm bolt × 36mm screw × 4).
- 3) Remove baffle from cylinder block. (6mm screw × 2).

6-3-3 AIR CLEANER

- 1) Remove air cleaner cover and element.
- 2) Detach bottom plate of air cleaner from carburetor by loosening two 6mm bolts.
(Also, detach the choke button from the carburetor chocke lever)
- 3) Disconnect breather pipe.

In reassembly;

Put air cleaner element in gasoline and sufficiently wash it while shaking until dust is completely removed. After washing, dry the element thoroughly and apply mixture oil (gasoline and mobile oil mixed at a ratio of 4:1), before reassembly.

6-3-4 MUFFLER

Remove muffler from cylinder part of crankcase (8mm nut × 2, 8mm bolt × 2).

6-3-5 GOVERNOR LEVER and CARBURETOR

- 1) Detach governor lever from governor lever shaft (6mm nut × 1).
- 2) Detach governor rod and rod spring from carburetor.
- 3) Remove carburetor from cylinder part of crankcase (EY33-2: 6mm nut × 2, EY44-2: 8mm nut × 2).

In reassembly:

Refer to "8. GOVERNOR ADJUSTMENT" section.

6-3-6 STARTING PULLEY and FLYWHEEL (magneto)

- 1) Remove 3 pieces mounting bolts to detach starting pulley from flywheel.
- 2) Remove flywheel from crankshaft.
Insert a socket wrench or box wrench into an 18mm nut, and give the wrench a sharp blow with a soft hammer. Remove nut and spring washer.
- 3) Attach flywheel puller to flywheel as shown in Fig. 6-3-1, and turn center bolt clockwise until flywheel becomes loose enough to be removed.
- 4) Disconnect high tension cable of ignition coil from spark plug, disconnect cable clip from crankcase, and then, remove ignition coil from crankcase (6mm x 25mm screw x 2).
- 5) Remove cable clip from lighting coil cable, and detach lighting coil from crankcase (6mm x 30mm screw x 2).
- 6) Remove breaker cover, and then remove contact breaker and condenser from crankcase.

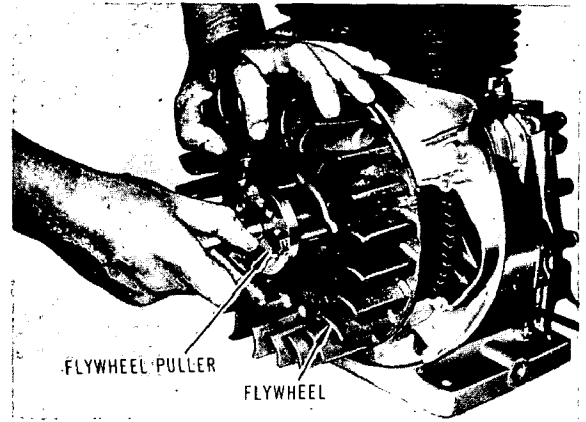

Fig. 6-3-1

In reassembly;

Refer to "7-2 BREAKER POINT ADJUSTMENT" and "7-3 TIMING ADJUSTMENT".

6-3-7 CYLINDER HEAD and SPARK PLUG

- 1) Detach spark plug from cylinder head.
- 2) Detach cylinder head and gasket from cylinder by loosening 10mm nut.

In reassembly;

- 1) Remove carbon from combustion chamber and also remove dirt from the vicinity of cooling fins of cylinder head. Check head face for distortion. Replace cylinder head, if needed.
- 2) Replace gasket with new one.
- 3) Clamping torque of cylinder head is 450~500 kg-cm (32.5~36 ft-lbs).

NOTE: Leave spark plug detached temporarily to facilitate engine rotation during timing adjustment. When mounting finally, tighten it 250~300 kg-cm (18~21.7 ft-lbs).

6-3-8 INTAKE and EXHAUST VALVE

- 1) Detach inner and outer tappet cover from cylinder block (6mm bolt x 2).
- 2) Detach retainer locks and valves by lifting valve spring using a valve spring retainer. Proceed in the same way both for intake valve and exhaust valve. (Fig. 6-3-2)
Then, remove valve springs and spring retainers.

CAUTION: DO NOT DAMAGE GASKET SURFACE OF TAPPET CHAMBER WITH THE COMPRESSOR TOOL.

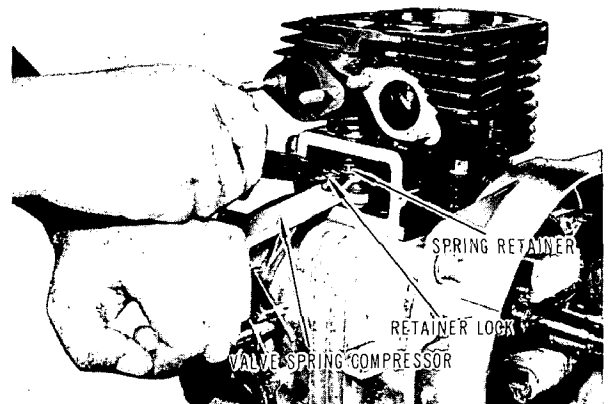

Fig. 6-3-2

In reassembly;

- 1) Clean carbon and gum deposits from the valves, seats, ports and valve stem holes.
- 2) Replace valves, if badly burned, pitted or warped.
- 3) Correct the valve seat by using 45° seat cutter tool as illustrated in Fig. 6-3-3. The seat should be finished to 1.2~1.5mm (.04~.05 inch) in width.
- 4) Cylinder block should be replaced if valve stem clearance becomes excessive. Refer to Fig. 6-3-4 for clearance specifications and proper assembly.
- 5) After correcting valve seats, lap valves in place until a uniform ring will show entirely around the face of the valve. Clean valves, and wash block thorough with a hot solution of soap and water. Wipe cylinder walls with clean lint free rags and light engine oil.

CAUTION: DO NOT ASSEMBLE VALVE SPRINGS AND SPRING RETAINERS AFTER ADJUSTING TAPPET CLEARANCE.

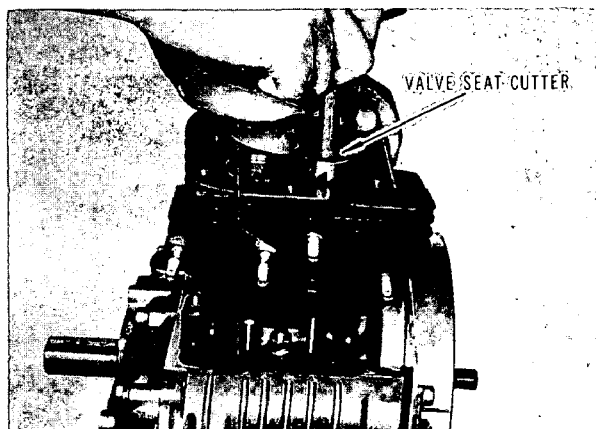
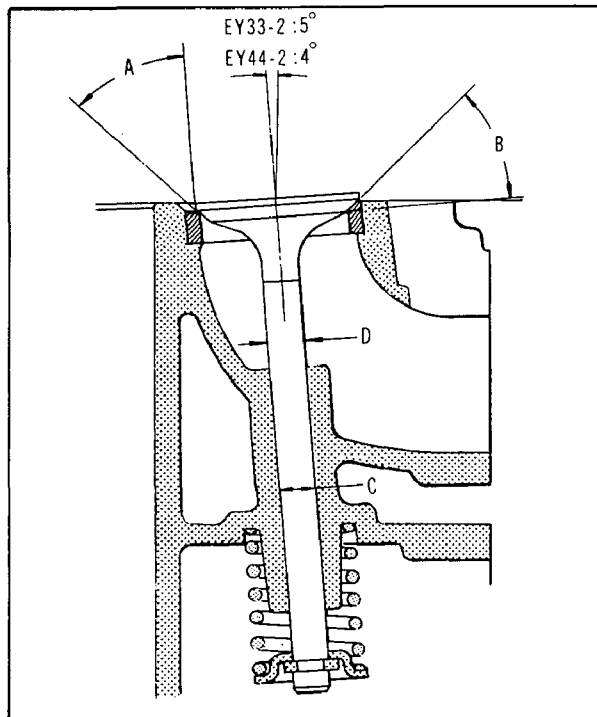

Fig. 6-3-3



VALVE and VALVE STEM HOLE CLEARANCE

A – VALVE FACE ANGLE		45°
B – SEAT ANGLE		45°
C – GUIDE INSIDE DIA.		8 DIA. $\begin{matrix} +0.036 \\ 0 \end{matrix}$ (.316''/.315'')
D – VALVE STEM DIA.	INTAKE	8 DIA. $\begin{matrix} -0.030 \\ -0.055 \end{matrix}$ (.316''/.313'')
	EXHAUST	8 DIA. $\begin{matrix} -0.090 \\ -0.110 \end{matrix}$ (.319''/.311'')
MAXIMUM ALLOWABLE CLEARANCE BETWEEN C and D	INTAKE	0.030~0.091 (.0012''~.0036'')
	EXHAUST	0.090~0.146 (.0035''~.0057'')

Fig. 6-3-4

6) ADJUSTING TAPPET CLEARANCE (Fig. 6-3-5)

- * Rotate crankshaft until tappet is in its lowest position, hold valve down and insert feeler gauge between valve and tappet stem. The clearance for both intake and exhaust, with engine cold.

0.13~0.17mm (0.0051" to 0.0067")

- * If clearance is less than specified, slightly grind valve stem and measure it again.
- * If clearance is larger than specified, sink valve seat to adjust clearance.
- * After clearance adjustment, assemble valve springs and valve retainers, and secure them in place with retainer locks. Check tappet clearance again for proper adjustment by turning crankshaft.

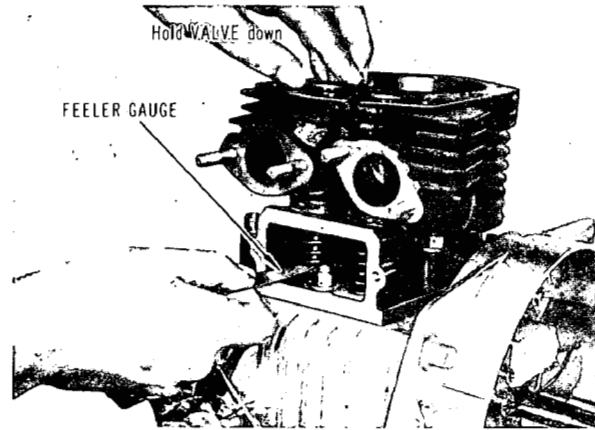

Fig. 6-3-5

6-3-9 CYLINDER BLOCK

Detach cylinder by loosening one 8mm and five 10mm nuts.

In reassembly;

- 1) Remove from upper surface of cylinder, carbon deposit which otherwise may damage piston when piston moves.
- 2) Insert a doubling plate between piston skirt and crankcase, and set piston to the cylinder center so that piston will not move easily. (Fig. 6-3-6).
- 3) Stagger the piston ring gaps 90° apart around piston.
- 4) Apply oil to piston ring and cylinder walls sufficiently.

NOTE: Use new cylinder gasket.

- 5) Check if piston moves smoothly after reassembly.

Clamping torque of cylinder is as shown below.

8mm nut 170~190 kg-cm (12.3~13.7 ft-lbs.)

10mm nut 350~400 kg-cm (25.3~29 ft-lbs.)

6-3-10 MAIN BEARING COVER

- 1) Unscrew 6mm bolt located just below crankshaft on driving shaft side of main bearing cover and 8 pieces bolts for mounting main bearing cover.
- 2) After setting crankshaft to the upper dead point of piston, insert a 4mm rod through 6mm screw hole to fix crankshaft as shown in Fig. 6-3-7. Then, evenly tap around the periphery of bearing cover with a soft hammer until cover breaks free from crankcase.

CAUTION: BE CAREFUL NOT TO DAMAGE OIL SEAL.

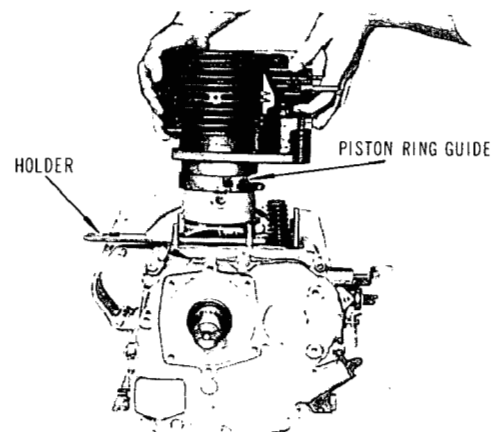

Fig. 6-3-6

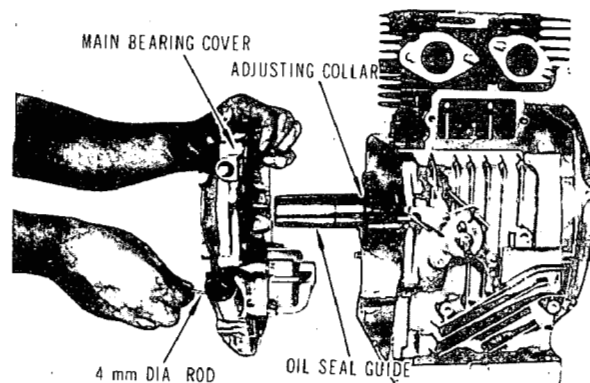

Fig. 6-3-7

In reassembly;

- 1) When reassembling main bearing cover, assemble governor lever shaft and governor arm before reinstalling them into crankcase.

NOTE: If replacement of oil seal is required, force-fit new oil seal before reassembly.

- 2) When reassembling main bearing cover, apply oil to bearing surfaces, gear train, tappets, and oil seal lips, and form a thin film of oil on main bearing cover face. Mount an oil seal guide onto crankshaft to prevent damage to oil seal lips.

NOTE: Turn crankshaft to TDC, and lock the balancer driven gear by inserting a 4mm dia. rod thru the plug hole and into a hole in the balancer driven gear (Fig 6-3-8)

- 3) Check if side clearance of crankshaft is 0~0.2mm, and adjust it using adjusting collar, if needed.
- 4) Clamping torque of mounting bolts for main bearing cover is 170~190 kg-cm (12.3~13.7 ft-lbs.).

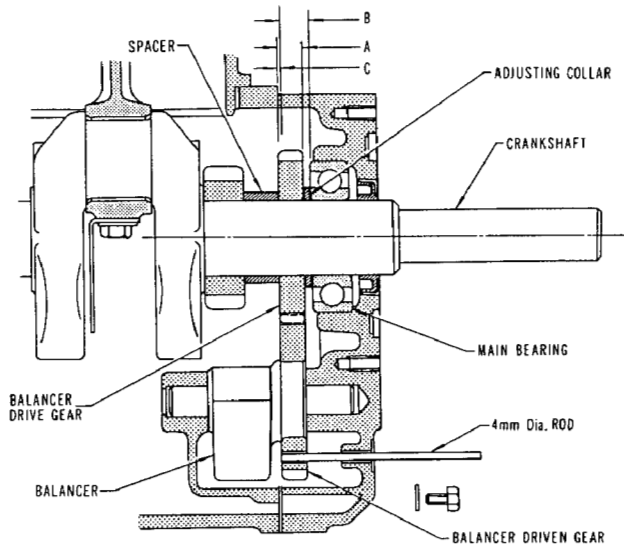

Fig. 6-3-8

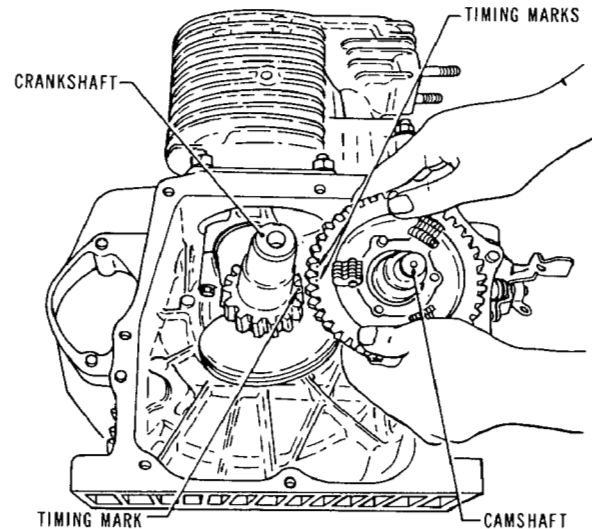

Fig. 6-3-9

6-3-11 CAMSHAFT and TAPPET

- 1) To prevent tappets from falling out and being damaged when camshaft is removed, turn crankcase over on its side as shown in Fig. 6-3-9. Push tappets inward to clear cam lobes, and remove camshaft.

- 2) Withdraw tappets.

NOTE: Mark them so that they can be reinstalled in the same holes.

In reassembly;

- 1) Put tappets back in their corresponding hole first and then mount camshaft.

CAUTION: DON'T FORGET TO MOUNT GOVERNOR SLEEVE ON CAMSHAFT.

- 2) Timing marks on camshaft gear and crankshaft gear must be matched up. If valve timing is off, engine will not function properly or may not run at all.

NOTE: Mount camshaft so that the marked tooth on crankshaft gear is between the two marked teeth of the camshaft gear. (Fig. 6-3-9)

6-3-12 CONNECTING ROD and PISTON

- 1) Straighten out the bent tabs of rod lock washer and remove bolts from connecting rod.
- 2) Remove oil scraper, lock washer and connecting rod cap from crankshaft.
- 3) Remove piston from connecting rod by detaching two clips, and then removing piston pin.
- 4) Remove piston rings from piston by widening open ends.

In reassembly;

• PISTON RING (See Fig. 6-3-10)

- 1) Use a ring expander tool to prevent ring from becoming distorted or broken when installing onto piston.

If an expander tool is not available, install rings by placing the open end of the ring on first land of piston. Spread ring only far enough to slip over piston and into correct groove, being careful not to distort ring. (Fig. 6-3-10)

NOTE: With or without expander tool, assemble bottom ring first and work upward, installing top ring last.

- 2) Assemble two pistons while facing maker's mark toward piston top.

CAUTION:

1. BE CAREFUL NOT TO BROKEN THE RING.
2. MOUNT SECOND RING WITH SCRAPER EDGE DOWN OTHERWISE OIL PUMPING AND EXCESSIVE OIL CONSUMPTION MAY RESULT. Refer to Fig. 6-3-11 for correct placement of rings.

• PISTON and CONNECTING ROD

Assemble piston and connecting rod using piston pin with clips mounted to both ends of piston pin.

NOTES:

1. Measure the clearance between cylinder and piston on thrust surface at skirt before assembly.
If worn out severer than specified, replace it.
2. Since the piston pin center of piston for EY44-2 is offset from the center of piston by about 6 mm, set piston to the match mark scribed at the top of piston. In case of Models B and D, set BF and DF marks to the  mark on the side of connecting rod before reassembly.

• ASSEMBLY of CONNECTING ROD

- 1) Assemble connecting rod so that the  mark on its side faces flywheel side.
- 2) Apply oil to large and small ends of connecting rod and crank pin sufficiently.
- 3) Assemble the connecting rod cap matching the marks on connecting rod.
- 4) Mount new lock washers and them without fail.

CAUTION: ASSEMBLE OIL SCRAPER WITHOUT FAIL, SO THAT THE TAB FACES TOWARD FLYWHEEL.

(When engine is operated while tilting it toward the PTO shaft side, assemble oil scraper tab on main bearing cover side.)

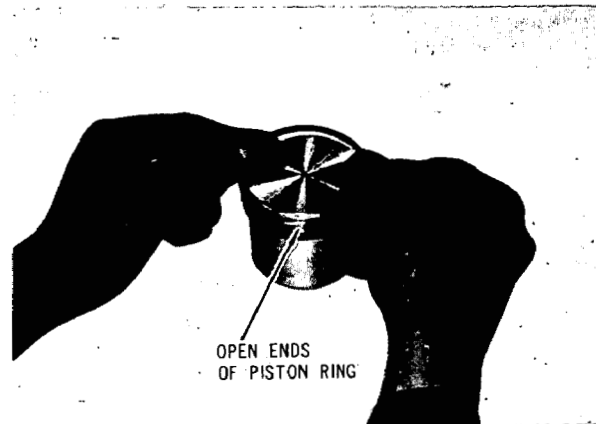

Fig. 6-3-10

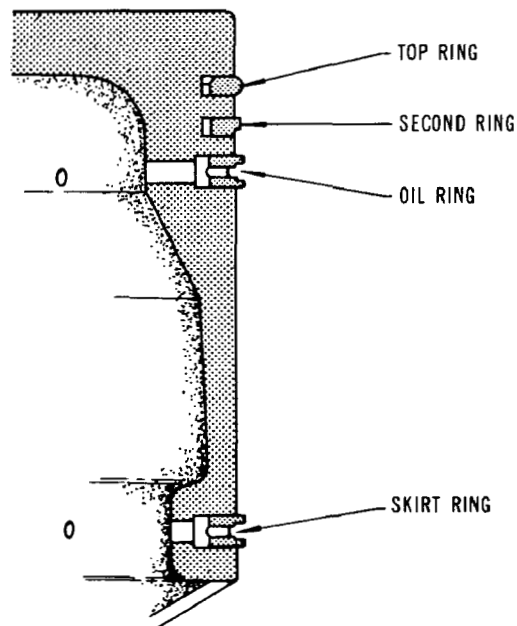

Fig. 6-3-11

5) Check if connecting rod moves smoothly after reassembly.

Clamping torque of connecting rod cap is 250~300 kg-cm (18~21.7 ft-lbs).

		EY33-2	EY44-2
D (crankshaft pin Dia.)		32 DIA. ± 0.008 (1.2598")	35 DIA. ± 0.008 (1.3779")
W (crankshaft pin Width)		27 ± 0.1 (1.0630")	30 ± 0.1 (1.1811")
PISTON TO CYLINDER AT PISTON SKIRT THRUST FACE (CLEARANCE)		0.150L~0.189L (.0059"L~.0074"L)	0.155L~0.177L (.0061"L~.0070"L)
PISTON RING GAP (CLEARANCE)	TOP RING SECOND RING OIL RING	0.05L~0.25L (.0020"L~.0098"L)	0.05L~0.25L (.0020"L~.0098"L)
	SKIRT RING	0.2L~0.4L (.0079"L~.0157"L)	0.3L~0.5L (.0118"L~.0197"L)
PISTON RING SIDE CLEARANCE IN GROOVES (CLEARANCE)	TOP RING	0.03L~0.07L (.0012"L~.0028"L)	0.03L~0.07L (.0012"L~.0028"L)
	SECOND RING		
	OIL RING		
	SKIRT RING		
CONNECTING ROD TO CRANK PIN (CLEARANCE)	DIA.	0.080L~0.112L (.0031"L~.0044"L)	0.040L~0.107L (.0016"L~.0042"L)
	SIDE	0.2L~0.5L (.0079"L~.0197"L)	0.2L~0.5L (.0079"L~.0197"L)
CONNECTING ROD TO PISTON PIN (CLEARANCE)		0.027L~0.046L (.0011"L~.0018"L)	0.025L~0.047L (.0010"L~.0019"L)
PISTON PIN TO PISTON (CLEARANCE)		0.009T~0.010L (.00035"T~.00039"L)	0.011T~0.011L (.0004"T~.0004"L)

6-3-13 CRANKSHAFT (Fig. 6-3-13)

- 1) Remove flywheel woodruff key.
- 2) Pull crankshaft out from open end of crankcase and take care not to damage the oil seal.

If necessary, loosen shaft by tapping lightly at flywheel end with a soft hammer.

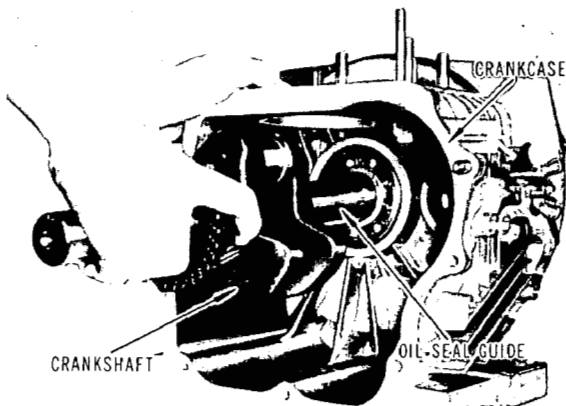

Fig. 6-3-13

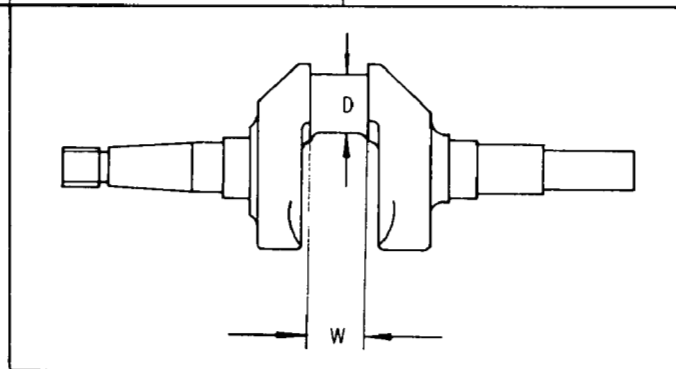

Fig. 6-3-12

7. MAGNETO

7-1 MAGNETO

In Models EY33-2 and EY44-2, ignition spark is furnished by a magneto.

The magneto is composed of the flywheel, ignition coil, lighting (charging) coil, breaker assembly (including condenser).

The flywheel is mounted on crankshaft, while ignition coil, lighting coil, and breaker assembly are directly assembled to crankcase.

7-2 BREAKER POINT ADJUSTMENT

The breaker points are mounted inside flywheel and directly assembled to crankcase. Check breaker points whenever ignition spark becomes weak. If there is evidence of pitting or pyramidding, the breaker points must be corrected and then, it becomes necessary to readjust the gap to its proper clearance (0.35mm, 0.014 inch).

The normal breaker point opening is 0.35mm at full separation. Since spark timing is regulated by point opening, use a timing light to obtain an accurate spark advance. To adjust the breaker point opening, remove starting pulley and flywheel from engine and observe following procedures. (see Fig. 7-2)

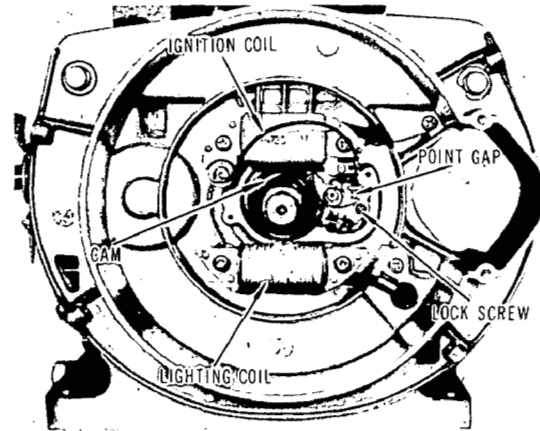

Fig. 7-2

- 1) Remove point cover from crankcase.
- 2) Turn the crankshaft until breaker arm comes in contact with the highest point of breaker cam (maximum point opening of 0.35mm).
- 3) Loosen contact support plate lock screw just enough to move bracket.
- 4) Insert a 0.35mm feeler gauge between points.
- 5) Apply a screwdriver to adjusting tab, and move contact support plate just enough to obtain specified gap, while opening and closing points.
- 6) Clamp the setscrew of contact support plate, and check the point gap again.
- 7) Pull a strip of 8 to 10mm wide white paper through closed points to remove dust and oil.
- 8) After adjustment, assemble the point cover, flywheel, and starting pulley to engine.

7-3 TIMING ADJUSTMENT

The spark is timed to occur 23° before the piston reaches TDC on the compression stroke. This spark advance of 23° is controlled by the breaker point opening and this advance is obtained when the breaker point opening is adjusted according to the BREAKER POINT ADJUSTMENT to 0.35mm (0.014 inch).

However, the advance timing is more accurately adjusted through the following procedures using a timing light as shown in Fig. 7-3-2.

For timing adjustment, the following alignment marks are provided:

- D type: D mark at lower left crankcase (see Fig. 7-3-1)
M mark and slit on flywheel circumference
- B type: B mark at upper left crankcase
M mark and slit on flywheel circumference.

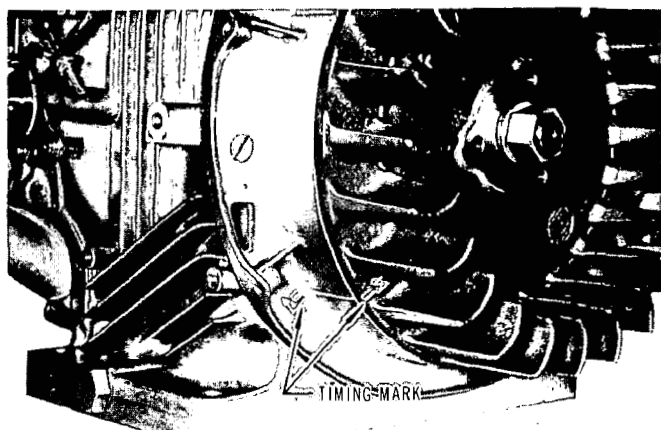

Fig. 7-3-1

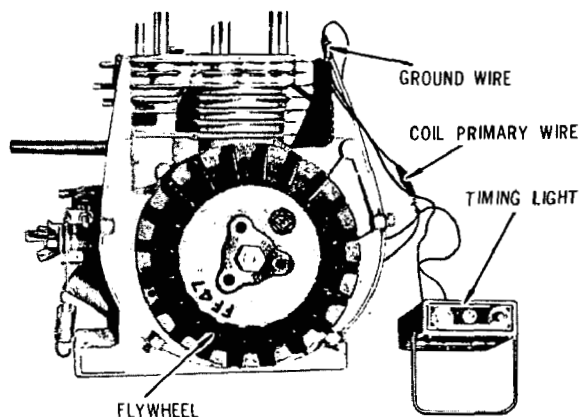

Fig. 7-3-2

For timing adjustment, the following procedures using a timing light: (See Fig. 7-3-2)

- 1) Disconnect the stop button lead wires and the coil primary wire.
 - 2) Remove blower housing from engine.
 - 3) Connect one of the timing light leads to the coil primary wire and ground the other lead to crankcase. (see Fig. 7-3-1)
While the points are open, the light remains on and when the points are closed, the light is extinguished.
 - 4) Turn flywheel slowly counter-clockwise (D type engines) or clockwise (B type engines) until the light extinguishes.
 - 5) Then, turn flywheel very slowly clockwise (D type engines) or counter-clockwise (B type engines) and stop immediately the moment the light lights up. Check if the slit on the flywheel is in the time with the mark on the crankcase. When the mark line is in alignment, the timing is correct.
 - 6) If the timing mark lines are not in alignment, then re-adjust the point opening according to the BREAKER POINT ADJUSTMENT, by removing the flywheel and repeat the checking procedures 3) through 5).
- After completing the timing adjustment, re-mount the blower housing and connect the coil primary lead to the stop button.

7-4 MAGNETO SERVICE INSTRUCTIONS

When engine does not start or starts with difficulty or when its operation is unstable, observe following tests to see if such a defect is caused by a defect in magneto.

- 1) Check ignition coil for looseness, corrosion, breakage, or abrasion.
- 2) Check sparking referring to "CHECKING THE IGNITION SPARK", given below.
- 3) Check if breaker points require cleaning or adjustment. If they are contaminated, corroded, or pitted, replace them. (Condenser may have to be replaced in this case) See "BREAKER POINT ADJUSTMENT".
- 4) If no spark takes place, replace ignition coil.

* CHECKING IGNITION SPARK

Remove spark plug from cylinder head and place it on cylinder head fin after connecting ignition cable to it. Crank engine several times by starting pulley, and check if plug gap spark is strong or weak.

If spark is weak, check it according to steps 1)~3) above. Correct plug gap is 0.6 to 0.7mm (.0236"~.0276").

8. GOVERNOR ADJUSTMENT

EY33-2 and EY44-2 employ a centrifugal flyweight type governor which is mounted on a cam gear to automatically regulate throttle valve of carburetor by mean of a lever, so that the engine speed is kept constant irrespective of load fluctuations.

For adjustment, observe following procedures. (see Fig. 8-1)

- 1) Connect carburetor throttle lever and governor lever with connecting rod, and mount them onto governor shaft.
- 2) Connect governor lever and control lever with governor spring and install control lever to crankcase.
- 3) Turn control lever counterclockwise until carburetor throttle valve is fully open. Lock control lever with butterfly nut.
- 4) With a screwdriver inserted into groove of governor shaft, turn it fully clockwise or counter-clockwise until lever shaft no longer moves, and then lock governor lever to governor shaft by tightening clamp nut.

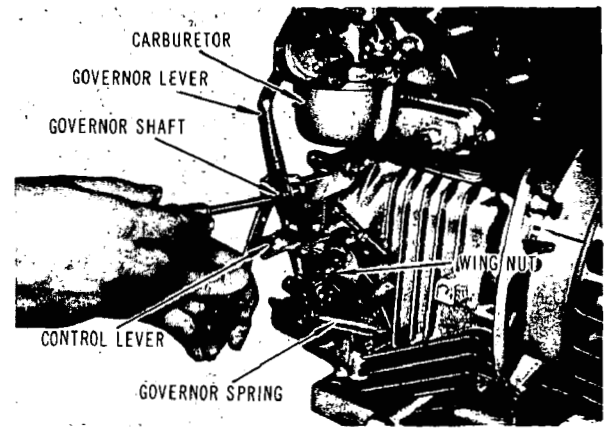

Fig. 8-1

9. CARBURETOR

9-1 OPERATION and CONSTRUCTION (see Figs. 9-1-1 and 9-1-2)

9-1-1 FLOAT SYSTEM

The float chamber is located just below carburetor main body and serves to maintain the fuel level at a constant height by a joint action of float (F) and needle valve (NV) incorporated. The fuel flows from the fuel tank into float chamber via needle valve, which is kept open while the fuel level is low, but closed when the fuel level reaches a predetermined level causing the float to move up.

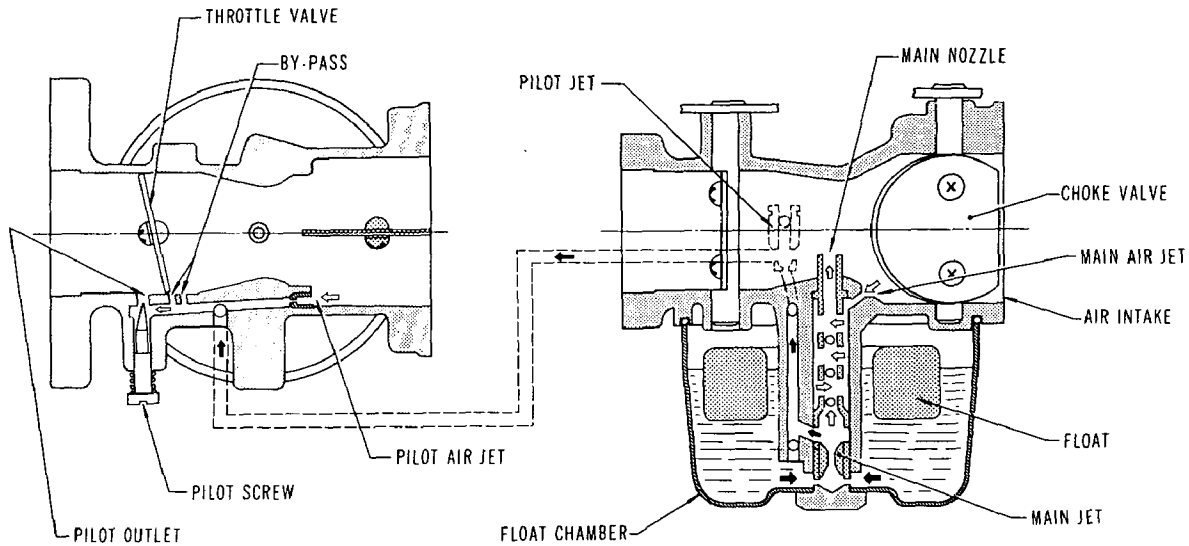

Fig. 9-1-1

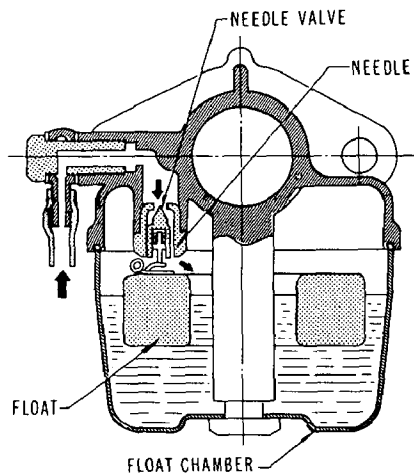

Fig. 9-1-2

9-1-2 PILOT SYSTEM

This pilot system feeds fuel to engine during idle and low speed operation.

The fuel fed through main jet (MJ) is measured by pilot jet (PJ), mixed with air measured by pilot air jet (PAJ), regulated by pilot screw, and then fed to engine through pilot outlet (PO) and bypass (BP).

The fuel is mainly fed from pilot outlet (PO) during idling.

9-1-3 MAIN SYSTEM

This system feeds fuel to engine during medium and high-speed operation.

The air measured by main air jet (MAJ) is mixed into fuel through bleed holes of main nozzle (MN) and discharged to main bore (MB) as atomized fuel where it is mixed with intake air through air cleaner to become an optimum air-fuel mixture to be supplied to engine.

9-1-4 CHOKE SYSTEM

The choke system serves to facilitate start-up in cold season. When engine is cranked with choke (C) closed, the negative pressure to main nozzle (MN) increases to introduce fuel in large quantities to make start-up easy.

9-2 DISASSEMBLY and REASSEMBLY

Besides mechanical failures, most troubles are caused by incorrect mixing ratio.

The most common causes of such incorrect fuel-air mixtures are clogged jets, restricted air and fuel passages, and variations in fuel level. In order to obtain the full performance of carburetor, it is necessary to keep air cleaner and carburetor clean so that air and fuel flow without any restriction.

Observe following disassembly and reassembly procedures. (See Fig. 9-2)

9-2-1 THROTTLE SYSTEM

- 1) Remove Philips-screw (11), remove throttle valve (15), and then pull out throttle shaft (16).
- 2) Detach spring (7) by unscrewing throttle stop screw (8).

9-2-2 CHOKE SYSTEM

- 1) Unscrew Philips-screw (11), remove choke valve (9), pull out choke shaft (10), and then remove choke ball (12) and choke spring (13).
- 2) When reassembling choke shaft, place the notch of choke valve on main air jet side.

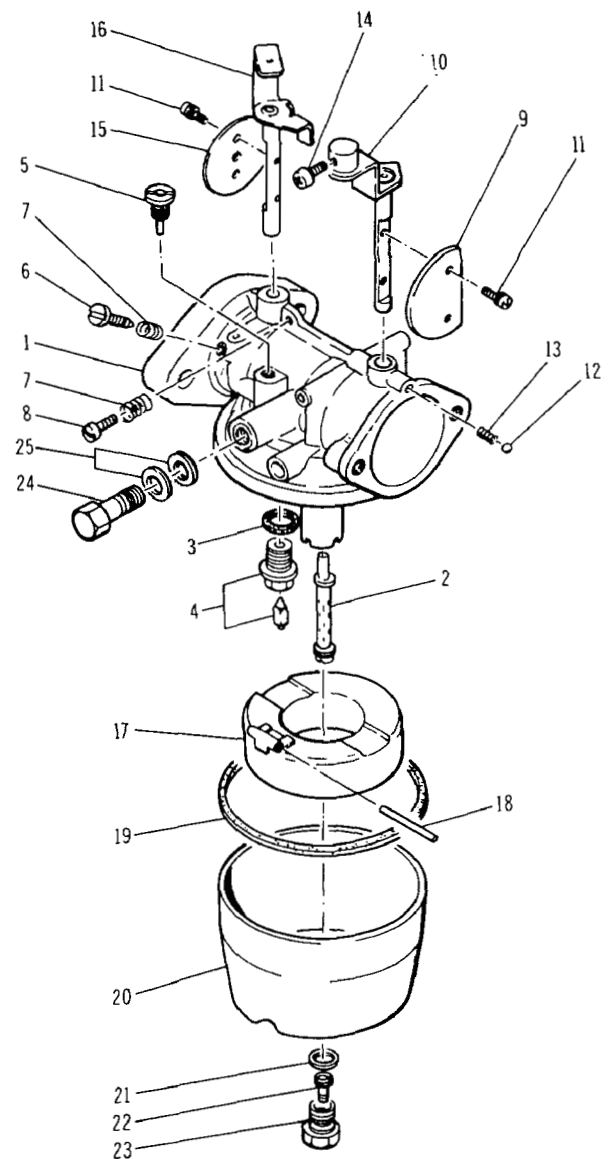

Fig. 9-2

9-2-3 PILOT SYSTEM

- 1) Remove pilot jet (5) using a suitable tool while taking care not to damage it.
- 2) Detach pilot screw (6) and spring (7).

In reassembly;

- 1) Clamp pilot jet securely, otherwise fuel leaks, causing engine failures.
- 2) If the tapered portion of pilot screw is deformed, replace it with new one. Avoid clamping it too tightly.

9-2-4 MAIN SYSTEM

- 1) Detach main jet holder (23), and remove float chamber body (20).
- 2) Detach main jet (22) from main jet holder (23).
- 3) Remove main nozzle (2) from carburetor main body.

In reassembly;

- 1) Clamp main jet to main jet holder securely, otherwise the fuel mixture is too rich, and an engine disorder may result.
- 2) Tighten main jet holder to a clamping torque of 70~80 kg-cm (5.1~5.8 ft-lbs.).

9-2-5 FLOAT SYSTEM

After pulling out float pin (18), detach float (17) and needle valve (4).

In reassembly;

When replacing needle valve, replace it together with valve seat without fail.

CAUTION: AVOID USING A DRILL OR A WIRE WHEN CLEANING JETS, OTHERWISE THE ORIFICE MAY BE DAMAGED, CAUSING UNFAVORABLE EFFECTS TO FUEL FLOW. USE COMPRESSED AIR WITHOUT FAIL.

9-3 ADJUSTMENT

- 1) Adjust pilot screw by turning it counter-clockwise by 1-1/2 turn (EY33-2) or 1-3/4 turn (EY44-2) after fully closing it once. Avoid clamping pilot screw excessively, otherwise needle point may broken.
- 2) Turn throttle top screw clockwise until the specified idling speed of 1,200rpm is obtained. If this speed exceeds 1,200rpm, turn throttle top screw counter-clockwise.
- 3) Make final adjustments with air cleaner mounted and also engine at normal operating temperature.

10. RUN-IN OPERATION OF ENGINE after REASSEMBLY

An overhauled engine must be carefully run-in to get proper engine surface conditions on newly installed parts. A thorough run-in operation is indispensable particularly when cylinder, piston, piston rings, or valves are replaced.

The recommended run-in schedule is as tabulated below.

LOAD		SPEED	TIME
EY33-2	EY44-2		
No load	No load	2500 r.p.m.	10 minutes
No load	No load	3000 r.p.m.	10 minutes
No load	No load	3600 r.p.m.	10 minutes
3.25 HP	4 HP	3600 r.p.m.	30 minutes
6.5 HP	8 HP	3600 r.p.m.	60 minutes

11. TROUBLE SHOOTING

For a satisfactory starting and running conditions of a gasoling engine, the following three requirements must be met:

1. The cylinder filled with a proper fuel-air mixture.
2. An appropriate compression in the cylinder.
3. Good spark at correct time to ignite the mixture.

If all three requirements are not met simultaneously, an engine can not be started. There are also other factors such as heavy load at starting and too long exhaust pipe causing high back pressure, which contribute to hard starting. The most common causes of engine troubles are given below.

11-1 STARTING DIFFICULTIES

11-1-1 FUEL SYSTEM

- 1) No gasoline in fuel tank, or fuel cock closed.
- 2) Carburetor insufficiently choked, especially when engine is cold.
- 3) Water, dirt or gum in gasoline hindering flow of fuel to carburetor.
- 4) Inferior or poor grade gasoline not vaporizing satisfactorily to produce correct fuel mixture.
- 5) Needle valve in carburetor held open by dirt or gum. This condition is ascertained by a continuous fuel drip from the carburetor during idling.

Sometimes, this trouble is remedied by lightly tapping the float chamber with a screw driver handle or the like.

- 6) Due to carburetor flooding, too much fuel introduced in the cylinder through cranking, making the mixture too rich to be ignited.

When this happens, remove spark plug and turn the engine over several times with starting pulley to evacuate over-rich mixture through the plug hole. Keep carburetor choke open during this operation. Dry spark plug thoroughly and reinstall, and try to start again.

11-1-2 COMPRESSION SYSTEM

When the fuel system and the ignition system are eliminated as the cause of starting difficulties and loss of power, the following are to be checked for possible lack of compression.

- 1) Cylinder dry after long interruption of operation.
- 2) Loose or broken spark plug. In this case, a hissing noise is audible, during cranking, made by escaping mixture gas in compression stroke.
- 3) Damaged head gasket or slack cylinder head tightening. A similar hissing noise is produced during compression stroke.
- 4) Tappet clearance incorrect. (See "6-3-8, 6) ADJUSTING TAPPET CLEARANCE")

If the compression is not recovered after correcting the above faults, the engine must be partly dismantled and the following must be checked.

- 1) Valve stuck open due to carbon or gum on valve stem.
- 2) Piston rings stuck in piston due to carbon accumulation. Remove piston and connecting rod from engine and clean, correct or replace parts.

11-1-3 ELECTRIC SYSTEM

When there is no spark, the following must be checked.

- 1) Disconnected cable leading to ignition coil, spark plug or contact breaker.
- 2) Broken ignition coil winding, causing short circuit.
- 3) Wet or oil soaked spark plug cable.
- 4) Dirty or wet spark plug.
- 5) Incorrect spark plug electrode gap.
- 6) Short connection of spark plug electrodes.
- 7) Pitted or fused breaker points.
- 8) Sticking breaker arm.
- 9) Leaking or grounded condenser.
- 10) Incorrect ignition timing.

11-2 ENGINE MISSES

- 1) Incorrect spark plug electrode gap.
- 2) Worn and leaking ignition cable.
- 3) Weak spark.
- 4) Loose connections in ignition wire.
- 5) Pitted or worn breaker points.
- 6) Gasoline containing water.
- 7) Poor compression.

11-3 ENGINE STOPS

- 1) Fuel tank empty. Gasoline contaminated with water, dirt or gum.
- 2) Gasoline vaporized in fuel lines due to excessive heating around engine. (Vapor lock)
- 3) Vapor lock in fuel lines or carburetor due to the use of too volatile winter gas in the hot season.
- 4) Air vent hole in fuel tank cap plugged.
- 5) Seizure in rotating or sliding pairs in engine due to lack of oil.
- 6) Ignition troubles.

11-4 ENGINE OVERHEATS

- 1) Crankcase oil supply low. Replenish immediately.
- 2) Incorrect spark timing.
- 3) Low grade gasoline is used.
Engine overloaded.
- 4) Restriction of cooling air circulation.
- 5) Cooling air partly misdirected causing loss to cooling efficiency.
- 6) Cylinder head cooling fins blocked with dirt.
- 7) Engine operated in closed space without fresh supply of cooling air.

- 8) Restriction of exhaust gas outlet.
Carbon deposit in combustion space.
- 9) Engine detonating due to low octane gasoline with heavy load at low speed.

11-5 ENGINE KNOCKS

- 1) Gasoline of poor quality or low octane rating.
- 2) Engine operating under heavy load at low speed.
- 3) Carbon or lead deposits in cylinder head.
- 4) Incorrect spark timing.
- 5) Loose or burnt out connecting rod bearing.
- 6) Worn or loose piston pin.
- 7) Engine overheated.

11-6 ENGINE BACKFIRES THROUGH CARBURETOR

- 1) Water or dirt in gasoline or poor grade of gasoline.
- 2) Sticky intake valve.
- 3) Overheated valves, or hot carbon particles in engine.
- 4) Engine cold.

12. CHECKS and CORRECTIONS

After dismantling and cleaning the engine parts, check them, and if necessary, correct them, according to the correction table.

The correction table applies whenever the engines are repaired. Its contents should be thoroughly understood by those who undertake the repairing. Its specifications must be abided by to effect correct maintenance.

Below, terms employed in the correction table are explained.

1) CORRECTION

All operations performed on the engine parts for the purpose of improving or recovering the engine performance, consisting of repair, readjustment, and replacement.

2) STANDARD SIZE

Design dimension of the part without the tolerance.

3) CORRECTION TOLERANCE

Tolerance on the re-finished part dimension or on the readjustment dimension.

4) CORRECTION LIMIT

Limit on the part and adjustment, beyond which any dimensional and functional change, due to wear, burn and other causes will adversely affect the normal engine performance.

5) USE LIMIT

Limit, beyond which the part is no longer usable, due to defects in function or strength.

6) All dimensions in the CORRECTION TABLE are give in millimeter, except where otherwise specified.

CORRECTION TABLE

ITEM	ENGINE MODEL	STANDARD SIZE	CORRECTION		USE LIMIT	REMARKS	TOOL	CORRECTION METHOD	
			TOLERANCE	LIMIT					
Flatness of cylinder head	EY33-2		0.05	0.15			Surface plate, Feeler	Correct	
	EY44-2								
Cylinder	Bore	EY33-2	78φ	+0.029 -0.010	0.15	0.65	Cylinder gauge	Boring	
		EY44-2	90φ	+0.057 -0.035					
	Roundness	EY33-2		0.01					
		EY44-2							
	Cylindricity	EY33-2		0.015					
		EY44-2							
Valve seat contact width	EY33-2 EY44-2		1.2~1.5			Seat cutter	Correct		
Valve guide I.D.	EY33-2 EY44-2	8φ	+0.036 0	0.15	0.15	At middle portion	Cylinder gauge	Replace	
Piston	O.D. at skirt, in thrust direction (inch. over size)	EY33-2	STD 77.87 0.25 } * 78.11 0.50 } * 78.36	0 -0.02	-0.1	-0.1	* Mark over size	Micro-meter	Replace
		EY44-2	STD 89.89 0.25 } * 90.14 0.50 } * 90.30						
	Width of ring groove	EY33-2	Top 2.5	+0.04 +0.02	0.15	0.15		Vernier calipers	Replace
		EY44-2	Oil SKIRT 4.0						
	Piston pin hole	EY33-2	18φ	+0.002 -0.009	0.035	0.035		Cylinder gauge	Replace
		EY44-2	20φ	+0.002 -0.011					
	Clearance between piston and cylinder	EY33-2		0.150~0.189	0.3	0.3	Max. cylinder dia. and piston dia. at skirt in thrust direction	Cylinder gauge, Micro-meter	Replace
EY44-2			0.115~0.177						
Clearance between piston ring and ring groove	EY33-2 EY44-2		0.03~0.07	0.15	0.15		Feeler gauge	Replace	
Fit between piston & piston pin	EY33-2		0.009T~0.010L	0.06L	0.06L		Cylinder gauge Micro-Meter	Replace	
	EY44-2		0.011T~0.011L						
Piston Ring	Ring gap	EY33-2	Top 0.05~0.25	1.5	1.5		Micro-meter	Replace	
		EY44-2	Oil SKIRT 0.3~0.5						
Ring width	EY33-2	Top 2.5	-0.01 -0.03	-0.1	-0.1		Micro-meter	Replace	
	EY44-2	Oil SKIRT 4.0							

ITEM	ENGINE MODEL	STANDARD SIZE	CORRECTION		USE LIMIT	REMARKS	TOOL	CORRECTION METHOD
			TOLERANCE	LIMIT				
Piston pin O.D.	EY33-2	18φ	0 -0.008	-0.03	-0.03		Micro- meter	Replace
	EY44-2	20φ	0 -0.009					
Connecting Rod	Large end I.D.	EY33-2	32φ	+0.016 -0	0.1	0.1	Cylinder gauge	Replace
		EY44-2						
	Clearance between rand large end I.D. and crankpin	EY33-2		0.080~0.112	0.2	0.2		Replace
		EY44-2		0.040~0.107				
	Small end I.D.	EY33-2	18φ	+0.038 +0.027	0.08	0.08	Cylinder gauge	Replace
		EY44-2	20φ	+0.038 +0.025				
	Clearance between small end I.D. and piston pin	EY33-2		0.027~0.046	0.12	0.12	Cylinder gauge, Micro- meter	Replace
		EY44-2		0.025~0.047				
	Large end side clearance	EY33-2		0.2~0.5	1.0	1.0	Feeler gauge	Re-machine or Replace
	EY44-2							
Parallelism between large end and	EY33-2		0.06	0.1	0.1	Test bar & Dial indicator	Re-machine or Replace	
EY44-2								
Distance between large end and small end bores	EY33-2	123			0.15			
	EY44-2	132						
Crankshaft	Crankpin O.D.	EY33-2	32φ	-0.080 -0.096	0.15	0.5	Micro- meter	Re-machine or Replace
		EY44-2	35φ	-0.080 -0.066				
	Crankpin O.D. roundness	EY33-2		0.005			Micro- meter	
	Crankpin O.D. cylindricity	EY33-2		0.005			Micro- meter	
		EY44-2						
Crankpin O.D. parallelism	EY33-2		0.01			Dial indicator		
Crankshaft journal O.D.	EY33-2	Drive S. 35φ	-0.003 -0.014			Micro- meter	Replace	
	EY44-2	Mag. S. 35φ	0 -0.011					
Camshaft	Cam lobe height	EY33-2	35	±0.1	-0.25	-0.25	Micro- meter	Replace
		EY44-2						
	Journal O.D.	EY33-2	Drive S. 30φ Mag. S. 25φ	-0.003 -0.012	0.05	0.05	Micro- meter	Replace

ITEM	ENGINE MODEL	STANDARD SIZE	CORRECTION		USE LIMIT	REMARKS	TOOL	CORRECTION METHOD	
			TOLERANCE	LIMIT					
Carnshaft	Journal O.D.	EY44-2	Drive S. 35φ	-0.003 -0.014	0.05	0.05		Micro-meter	Replace
			Mag. S. 25φ	-0.003 -0.012					
Valve spring	Free length	EY33-2 EY44-2	46		-1.5	-1.5		Vernier calipers	Replace
	Squareness	EU33-2 EY44-2				1.0	For total length	Square	Replace
Intake & Exhaust Valves	Valve stem O.D.	EY33-2	Intake 8φ	-0.030 -0.055	-0.15			Micro-meter	Replace
		EY44-2	Exhaust 8φ	-0.090 -0.110					
	Clearance between stem and guide	EY33-2	Intake	0.030~0.091	0.3	0.3	At middle	Cylinder gauge	Replace
		EY44-2	Exhaust	0.090~0.146					
	Tappet clearance	EY33-2 EY44-2		0.13~0.17	0.05 0.25			Feeler	Correct
	Clearance between groove and retainer	EY33-2 EY44-2		0.04~0.15	0.5	0.5		Feeler	Correct
Stem end length		EY33-2 EY44-2	4.75		-0.5	-0.5		Vernier calipers	Replace
Tappet	Total length	EY33-2	67.5	±0.05	-0.5	-0.5		Vernier calipers	Replace
		EY44-2	77.5						
	Clearance between stem and guide	EY33-2 EY44-2		0.025~0.062	0.2	0.2		Cylinder gauge & Micro-meter	Replace
Carburetor	Main jet unscrew	EY33-2	Fixed				#95		
		EY44-2					#125		
	Pilot screw unscrew	EY33-2	1½	±1/4					
		EY44-2	1%						
Electric Device	Spark plug	EY33-2 EY44-2	NGK B-6HS						
	Spark gap	EY33-2 EY44-2		0.6~0.7	1.0			Feeler	Adjust or Replace
	Spark timing	EY33-2 EY44-2	23° before T.D.C.	±3°	±5°			Timing tester	Adjust
	Point opening	EY33-2 EY44-2	0.35		±0.05	±0.1			Contact breaker spanner

ITEM	MODEL	HP/rpm	CORRECTION LIMIT	REMARKS
Max. Output	EY33-2	8.0/3,600	Below 110% of rated output	
	EY44-2	10.0/3,600		
Continuous Rated Output	EY33-2	6/3,600		
	EY44-2	8/3,600		

ITEM	MODEL	liter/hr	CORRECTION LIMIT	REMARKS
Fuel Consumption	EY33-2	3.1	up 135% Standard Consumption	at Continuous Rated Output
	EY44-2	3.6		

ITEM	MODEL	cc/hr	USE LIMIT cc/hr	REMARKS
Lubricant Consumption	EY33-2	30	60	
	EY44-2	40	80	

ITEM	MODEL	liter	REMARKS
Specified Lubricant Quality	EY33-2	1.4	Use the class SC or higher grade Mobile Oil Below -10°C (14°F) SAE 10W-30 -10°C (14°F) ~ 20°C (68°F) SAE #20 20°C (68°F) ~ 40°C (104°F) SAE #30
	EY44-2		

ITEM	MODEL	FREQUENCY OF OIL CHANGING
Oil Change	EY33-2	First Time: Change oil after 20 hours operation. Second Time and Thereafter: Change oil every 50 hours operation
	EY44-2	

ITEM	MODEL	kg/cm ² /rpm	CORRECTION LIMIT	TOOL
Compression Pressure	EY33-2	5.0/500	70% of normal value	Pressure gauge
	EY44-2			

ITEM	MODEL	rpm	TOOL	REMARKS
Min. accelerating revolution	EY33-2	1,150	Tachometer	
	EY44-2			

	ITEM	MODEL	kg-cm	ft-lb	TOOL	REMARKS
Tightening Torque	Cylinder head clamp nuts	EY33-2	450~500	32.5~36	Torque wrench	
		EY44-2				
	Connecting rod bolts	EY33-2	250~300	18~21.7	Torque wrench	
		EY44-2				
	Magneto clamp nuts	EY33-2	800~1,000	57.9~72.3	Torque wrench	
EY44-2						
Main bearing cover bolts	EY33-2	170~190	12.3~13.7	Torque wrench		
	EY44-2					
Spark plug	EY33-2	250~300	18~21.7	Torque wrench		
	EY44-2					

13. MAINTENANCE and STORING

The following maintenance jobs apply when the engine is operated correctly under normal conditions. The indicated maintenance intervals are by no means guarantees for maintenance free operations during these intervals.

For example, if the engine is operated in extremely dusty conditions, the air cleaner should be cleaned every day, instead of every 50 hours.

13-1 DAILY CHECKS and MAINTENANCE

Checks and maintenance	Reasons for requiring them
Remove dust from whatever parts which accumulated dust.	The governor linkage is especially susceptible to dust.
Check external fuel leakage. If any, retighten or replace.	Not only wasteful but also dangerous.
Check screw tightening. If any loose one is found, re-tighten.	Loose screws and nuts will result in vibration accidents.
Check oil level in crankcase and add up as necessary	If the engine is operated without sufficient oil, it will fail.

13-2 EVERY 20 HOURS CHECKS and MAINTENANCE

Checks and maintenance	Reasons for requiring them
Change crankcase oil	To remove run-in wear particles.

13-3 EVERY 50 HOURS (10 DAY) CHECKS and MAINTENANCE

Checks and maintenance	Reasons for requiring them
Change crankcase oil	Contaminated oil acceralates wear.
Clean air cleaner	Clogged air cleaner harms engine operation.
Check spark plug. If contaminated, wash in gasouine or polish with emery paper.	Output power is reduced and starting is made difficult.

13-4 EVERY 100 – 200 HOURS (MONTHLY) CHECKS and MAINTENANCE

Checks and maintenance	Reasons for requiring them
Clean fuel filter and fuel tank.	The engine will be out of order
Clean contact breaker points.	The engine output drops.

13-5 EVERY 500 – 600 HOURS (SEMIANUAL) CHECKS and MAINTENANCE

Checks and maintenance	Reasons for requiring them
Remove cylinder head and remove carbon deposit.	The engine will be out of order.
Disassemble and clean carburetor.	

13-6 EVERY 1000 HOURS (YEARLY) CHECKS and MAINTENANCE

Checks and maintenance	Reasons for requiring them
Perform overhauls, clean correct or replace parts.	The engine output drops and become out of order.
Change piston rings	

13-7 PREPARATION for LONG ABEYANCE

- 1) Perform the above 13-1 and 13-2 maintenance jobs.
- 2) Drain fuel from the fuel tank and carburetor float chamber.
- 3) To prevent rust in the cylinder bore, apply oil through the spark plug hole and turn the crankshaft several turns by hand. Re-install the plug.
- 4) Turn the starting pulley by hand and leave it where the resistance is the heaviest.
- 5) Clean the engine outside with oiled cloth.
- 6) Put a vinyl or other cover over the engine and store the engine in dry place.



Robin Engine



Robin Engine



Robin America, Inc.

940 Lively Blvd., Wood Dale, IL 60191 • Tel: (708) 350-8200 • Fax: (708) 350-8212

Free Manuals Download Website

<http://myh66.com>

<http://usermanuals.us>

<http://www.somanuals.com>

<http://www.4manuals.cc>

<http://www.manual-lib.com>

<http://www.404manual.com>

<http://www.luxmanual.com>

<http://aubethermostatmanual.com>

Golf course search by state

<http://golfingnear.com>

Email search by domain

<http://emailbydomain.com>

Auto manuals search

<http://auto.somanuals.com>

TV manuals search

<http://tv.somanuals.com>