

# TASCAM

TEAC Professional Division

D00966100B

# GA-30CD

## Instrument Amplifier

**OWNER'S MANUAL**

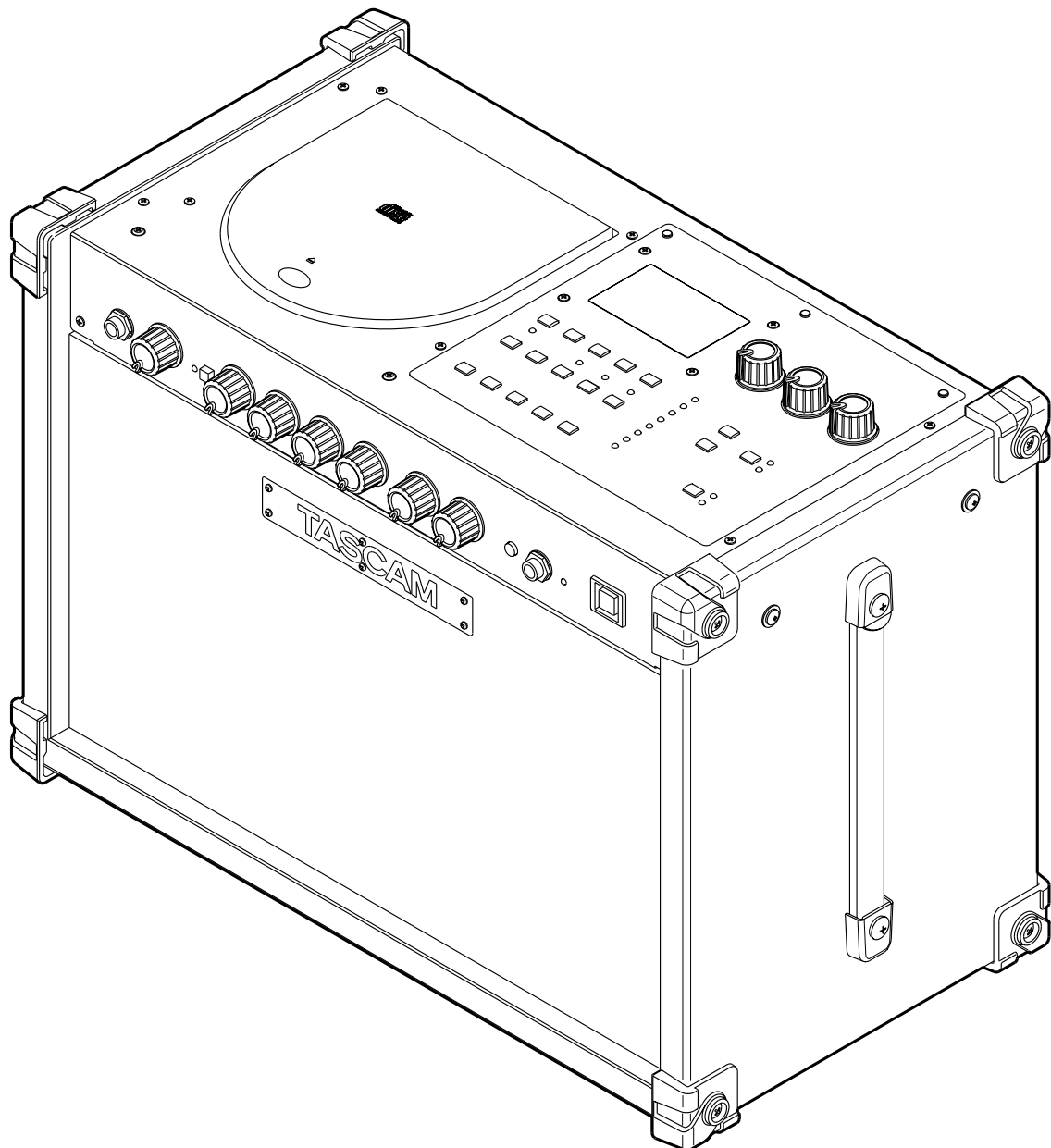

# IMPORTANT SAFETY PRECAUTIONS



**CAUTION**  
RISK OF ELECTRIC SHOCK  
DO NOT OPEN



**CAUTION: TO REDUCE THE RISK OF ELECTRIC SHOCK, DO NOT REMOVE COVER (OR BACK). NO USER-SERVICEABLE PARTS INSIDE. REFER SERVICING TO QUALIFIED SERVICE PERSONNEL.**



The lightning flash with arrowhead symbol, within equilateral triangle, is intended to alert the user to the presence of uninsulated "dangerous voltage" within the product's enclosure that may be of sufficient magnitude to constitute a risk of electric shock to persons.



The exclamation point within an equilateral triangle is intended to alert the user to the presence of important operating and maintenance (servicing) instructions in the literature accompanying the appliance.

This appliance has a serial number located on the rear panel. Please record the model number and serial number and retain them for your records.

Model number \_\_\_\_\_

Serial number \_\_\_\_\_

**WARNING: TO PREVENT FIRE OR SHOCK HAZARD, DO NOT EXPOSE THIS APPLIANCE TO RAIN OR MOISTURE.**

For U.S.A.

## TO THE USER

This equipment has been tested and found to comply with the limits for a Class B digital device, pursuant to Part 15 of the FCC Rules. These limits are designed to provide reasonable protection against harmful interference in a residential installation. This equipment generates, uses, and can radiate radio frequency energy and, if not installed and used in accordance with the instruction manual, may cause harmful interference to radio communications.

However, there is no guarantee that interference will not occur in a particular installation. If this equipment does cause harmful interference to radio or television reception, which can be determined by turning the equipment off and on, the user is encouraged to try to correct the interference by one or more of the following measures.

- a) Reorient or relocate the receiving antenna.
- b) Increase the separation between the equipment and receiver.
- c) Connect the equipment into an outlet on a circuit different from that to which the receiver is connected.
- d) Consult the dealer or an experienced radio/TV technician for help.

## CAUTION

Changes or modifications to this equipment not expressly approved by TEAC CORPORATION for compliance could void the user's authority to operate this equipment.

In North America use only 120V power supply.

# IMPORTANT SAFETY INSTRUCTIONS

- 1 Read these instructions.
  - 2 Keep these instructions.
  - 3 Heed all warnings.
  - 4 Follow all instructions.
  - 5 Do not use this apparatus near water.
  - 6 Clean only with dry cloth.
  - 7 Do not block any ventilation openings. Install in accordance with the manufacturer's instructions.
  - 8 Do not install near any heat sources such as radiators, heat registers, stoves, or other apparatus (including amplifiers) that produce heat.
  - 9 Do not defeat the safety purpose of the polarized or grounding-type plug. A polarized plug has two blades with one wider than the other. A grounding type plug has two blades and a third grounding prong. The wide blade or the third prong are provided for your safety. If the provided plug does not fit into your outlet, consult an electrician for replacement of the obsolete outlet.
  - 10 Protect the power cord from being walked on or pinched particularly at plugs, convenience receptacles, and the point where they exit from the apparatus.
  - 11 Only use attachments/accessories specified by the manufacturer.
  - 12 Use only with the cart, stand, tripod, bracket, or table specified by the manufacturer, or sold with the apparatus. When a cart is used, use caution when moving the cart/apparatus combination to avoid injury from tip-over.
- Do not expose this apparatus to drips or splashes.
  - Do not place any objects filled with liquids, such as vases, on the apparatus.
  - Do not install this apparatus in a confined space such as a book case or similar unit.
  - The apparatus should be located close enough to the AC outlet so that you can easily grasp the power cord plug at any time.
  - An apparatus with Class I construction shall be connected to an AC outlet with a protective grounding connection.
  - Batteries (battery pack or batteries installed) should not be exposed to excessive heat such as sunshine, fire or the like.
  - Excessive sound pressure from earphones and headphones can cause hearing loss.
  - The apparatus draws nominal non-operating power from the AC outlet with its STANDBY/ON in the Standby position.



- 13 Unplug this apparatus during lightning storms or when unused for long periods of time.
- 14 Refer all servicing to qualified service personnel. Servicing is required when the apparatus has been damaged in any way, such as power-supply cord or plug is damaged, liquid has been spilled or objects have fallen into the apparatus, the apparatus has been exposed to rain or moisture, does not operate normally, or has been dropped.

# Safety Information

This product has been designed and manufactured according to FDA regulations "title 21, CFR, chapter 1, subchapter J, based on the Radiation Control for Health and Safety Act of 1968", and is classified as a class 1 laser product. There is no hazardous invisible laser radiation during operation because invisible laser radiation emitted inside of this product is completely confined in the protective housings. The label required in this regulation is shown at ①.

①

For U.S.A.

## CERTIFICATION

THIS PRODUCT COMPLIES WITH DHHS RULES 21 CFR SUBCHAPTER J APPLICABLE AT DATE OF MANUFACTURE

TEAC CORPORATION  
3-7-3 NAKA-CHO, MUSASHINO-SHI, TOKYO, JAPAN  
MANUFACTURED **DTA**

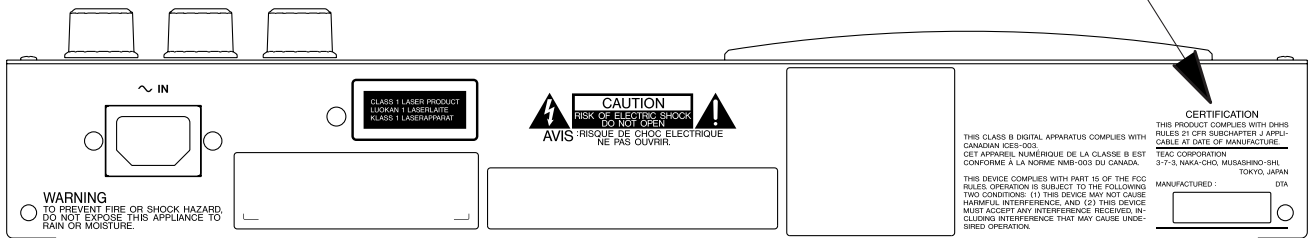

## CAUTION

- DO NOT REMOVE THE PROTECTIVE HOUSING USING A SCREWDRIVER.
- USE OF CONTROLS OR ADJUSTMENTS OR PERFORMANCE OF PROCEDURES OTHER THAN THOSE SPECIFIED HEREIN MAY RESULT IN HAZARDOUS RADIATION EXPOSURE.
- IF THIS PRODUCT DEVELOPS TROUBLE, CONTACT YOUR NEAREST QUALIFIED SERVICE PERSONNEL, AND DO NOT USE THE PRODUCT IN ITS DAMAGED STATE.
- WHEN USING THE GA-30CD, USE ONLY THE SUPPLIED POWER CABLE.
- CLASS 1M INVISIBLE LASER RADIATION WHEN OPEN AND INTERLOCKS DEFEATED. DO NOT VIEW DIRECTLY WITH OPTICAL INSTRUMENTS.

The GA-30CD uses either a SONY or a SAMSUNG transport.

### Optical pickup:

Type: KSM-900AAA  
Manufacturer: SONY Corporation  
Laser output: Less than 1 mW on the objective lens  
Wavelength: 775 to 816 nm

Type: CMS-M93BG6  
Manufacturer: Samsung Electro-Mechanics Co., Ltd.  
Laser output: Less than 0.4 mW on the objective lens  
Wavelength: 760 to 800 nm

<b>1 – Introduction</b> .....	6	<b>6 – Using the CD trainer</b> .....	16
Main features of the GA-30CD .....	6	Playing CDs .....	16
Supplied accessories .....	6	Changing the time display mode .....	16
Understanding this manual .....	6	Repeat playback of a selected loop .....	16
Handling of compact discs .....	7	Stopping loop playback .....	16
Beware of condensation .....	7	All track or single track repeat playback .....	16
Precautions for placement and use .....	7	Setting the tempo .....	16
<b>2 – Part names and functions</b> .....	8	Turning tempo control ON and OFF .....	17
Front panel .....	8	Changing tempo without changing key .....	17
Top Panel .....	9	Adjusting the key .....	17
CD Trainer Section .....	9	Turning key adjustment ON and OFF .....	17
Effects Section .....	10	Canceling guitar sounds .....	17
Rear panel .....	11	Setting the Guitar Cancel function .....	17
CD Trainer LCD .....	11	<b>7 – Tuner, oscillator and metronome</b> .....	18
<b>3 – Connections</b> .....	12	Using the tuner .....	18
Guitar connection .....	12	Calibrating the tuning frequency .....	18
Headphones connection .....	12	Tuning in chromatic mode .....	18
External sound source connection .....	12	Tuning in guitar mode .....	18
<b>4 – Using the guitar amp</b> .....	13	Using the oscillator .....	18
Adjusting the volume and tone quality .....	13	Using the metronome .....	18
Procedures to shape the guitar tone .....	13	<b>8 – Changing settings</b> .....	19
<b>5 – Using effects</b> .....	14	Playback mode selection .....	19
Effects .....	14	Tuner settings .....	19
Selecting effects and setting parameters .....	14	Tuner speaker output .....	19
Restoring the factory effect presets .....	14	Initializing effect banks .....	19
Effect controls .....	14	<b>9 – Specifications</b> .....	20
Choosing the output .....	15	Guitar amplifier .....	20
Reverb .....	15	CD Trainer .....	20
Effect banks .....	15	Physical .....	20
Changing banks .....	15	Block diagram .....	21
		Dimensional drawing .....	21

# 1 – Introduction

Thank you for purchasing a TASCAM GA-30CD instrument amplifier. This guitar amp has 30 watts of total output from the 6.5-inch center speaker and two 3-inch stereo speakers. TASCAM's unique NeoTube technology and the high-quality built-in effects give you the freedom to craft guitar tones without needing additional external effects. You can also practice along with your favorite music, play prerecorded backing

tracks during performances and otherwise use the built-in CD player as you like.

Please study this manual thoroughly before using the amp so that you understand how to use it properly. We hope that with this knowledge you will enjoy using the GA-30CD and all of its features for many years. After you have finished reading this manual, please keep it in a safe place for future reference.

---

## Main features of the GA-30CD

---

### Guitar amp

- 15W output, 6.5-inch (16.5 cm) center speaker
- 3-band EQ allows flexible tone-shaping
- Boost circuit allows you to switch between clean and overdrive sounds with the press of a button

### DSP effects

- Two built-in TASCAM DSP effect units provide a reverb and a choice of stereo delay, panning delay, flanger, phaser, chorus, tremolo, auto-wah, or pitch shifter effects
- Effects can be output from the center speaker or from the left and right side speakers for spacious sounds

### CD Trainer

- Popular TASCAM CD Trainer built in
- Playback pitch and tempo freely controllable
- Variable Speed Audition (VSA) allows playback speed to be changed without changing the pitch
- Speed adjustment from -50% to +16%
- Pitch adjustment up or down 6 semitones
- Guitar Cancel function allows specified frequency and stereo ranges to be cut during playback
- Loop playback allows repetition of a selected passage
- Independent stereo amp (7.5W + 7.5W) and two 3-inch (7.6-cm) side speakers provide clear playback
- Built-in guitar tuner for easy tuning
- Built-in metronome and oscillator

### Other features

- Stereo line input jack for connection of external sound sources
- Headphone jack

---

## Supplied accessories

---

In addition to this manual, the GA-30CD has been packed with the items listed to the right.

Contact your TASCAM supplier if any of these items are missing.

- AC power cable..... 1
- Warranty ..... 1

---

## Understanding this manual

---

We use the following conventions in this manual:

- The names of keys and controls are given in the following typeface: **REVERB**.
- Messages shown in the alphanumeric portion of the LCD are given in the following typeface: **TMOD**.
- If a preset indicator in the display (i.e. one that cannot change, but is either on or off) is shown, this is given as follows: **TEMPO**.
- Selectable values (e.g. values of dB) and ON and OFF selections are shown in the following typeface: **CHR**. (e.g. **VBR>ON**)

- The GA-30CD has keys that function differently depending on whether they are pressed briefly (less than half a second) or pressed and held (more than half a second). In this manual, instructions to press a key, for example, “press **VSA**,” refer to brief presses, while instructions to “press and hold the key” or, for example, “press and hold **OSC**” refer to long presses.
- The CD Trainer Control LCD usually shows the elapsed track time, remaining track time or total remaining CD time. In this manual, this is referred to as the “time display.”

## Handling of compact discs

The GA-30CD has been designed for the playback of CD-DA (standard audio) format discs. In addition to ordinary 3-inch and 3-inch CDs, it can also play properly recorded CD-R and CD-RW discs.

- Always place CDs in the tray with their labeled sides facing upward.
- To remove a disc from its case, press down on the center of the disc holder, then lift the disc out, holding it carefully by the edges.

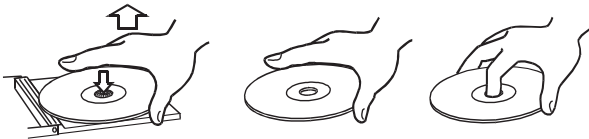

- Avoid getting fingerprints on the signal side (the non-label side). Grime and dust may cause skipping, so keep discs clean and store them in their cases when not being played. To clean the signal side of a disc, wipe gently with a soft dry cloth from the center towards the outside edge.



- Do not use any record spray, anti-static solutions, benzene, paint thinner or other chemical agents to clean CDs as they could damage the delicate playing surface. This may cause CDs to become unplayable.
- Discs should be returned to their cases after use to avoid serious scratches that could cause the laser pickup to “skip.”

- Keep discs away from direct sunlight, and places of high heat and humidity. If left in such places, warping could result.
- Do not affix any labels or stickers to the label side of the disc. Do not write on the disc with ballpoint pens.
- Do not use cracked discs.
- Only use circular compact discs. Avoid using non-circular promotional discs, etc.

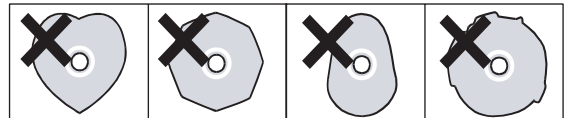

- The GA-30CD cannot play CD-R/RW discs that are not finalized.
- Several record companies have released music discs that use Copy Control and other copy-protection systems in an effort to prevent piracy. Since some of these discs do not comply with the CD specifications, the GA-30CD may not be able to play them.
- After opening the CD player cover, if the CD is still spinning, wait until it has stopped before removing it.

### CAUTION

*Using commercially available CD stabilizers or printable recordable discs with this player will damage the mechanism and cause it to malfunction.*

*Never use a disc that has had a stabilizer mounted to it. The residual adhesive may cause the disc to stick to the turntable of the GA-30CD. If it sticks to the turntable, you will need a technician to get it out.*

## Beware of condensation

If the unit (or a compact disc) is moved from a cold to a warm place, or used after a sudden temperature change, there is a danger of condensation; vapor in the air could condense on the internal mechanism, making correct

operation impossible. To prevent this, or if this occurs, let the player sit for one or two hours at the new room temperature before using

## Precautions for placement and use

Do not place the unit in the following types of places. Placement in such locations may cause malfunction or reduce sound quality.

- Unstable places or places with frequent vibrations
- Near windows or in direct sunlight
- Near heating devices or other extremely hot places
- Extremely cold places
- Damp or poorly ventilated places

Placing this amplifier near another power amplifier or another device with a large transformer can cause hum.

Adjust the distance and angle between the devices if this occurs.

Operation of the GA-30CD near a television or radio may cause color distortion on the television screen or noise in the radio signal. If this occurs, move the GA-30CD farther away.

Use of mobile phones and other wireless devices near the GA-30CD may cause the amp to produce noise during use or when calls are made or received. If this occurs, turn off the device or move it away from the GA-30CD.



# 2 – Part names and functions

## Front panel

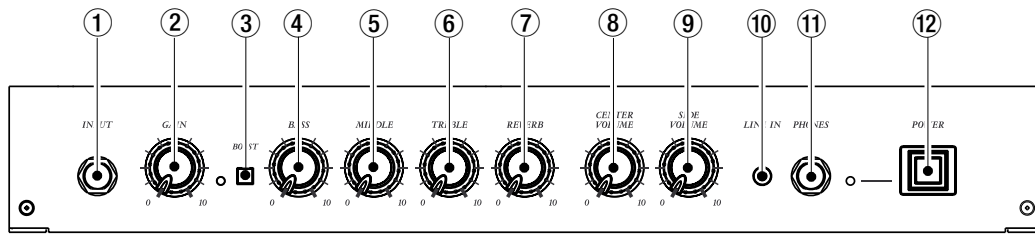

### ① INPUT jack

Plug your guitar into this high impedance jack using an ordinary guitar cable.

### ② GAIN knob

Change the input gain to adjust the volume of the guitar signal.

### ③ BOOST switch

Turns the internal distortion circuit ON and OFF.

OFF: The input guitar sound is heard clearly without distortion. The GAIN knob changes the input signal volume.

ON: The activated distortion circuit produces a more powerful guitar sound. When ON, the indicator to the left of the BOOST switch lights. The GAIN knob changes both volume and the amount of distortion.

### ④ BASS knob

Adjust low frequencies.

### ⑤ MIDDLE knob

Adjust mid-range frequencies.

### ⑥ TREBLE knob

Adjust high frequencies.

### ⑦ REVERB knob

Adjust the reverb signal output level.

The signal from the guitar preamp is sent to the built-in reverb and output through the **Center** speaker.

### ⑧ CENTER VOLUME knob

Adjust the volume of the total output signal sent to the center speaker (6.5-inch). In addition to the guitar preamp output, the effects output can also be sent to the center speaker.

### ⑨ SIDE VOLUME knob

Adjust the volume of the total output signal sent to the two side speakers (3-inch). In addition to the CD Trainer output, the effects output can also be sent to the side speakers.

#### NOTE

The **SIDE VOLUME** level is set to play CDs that have low overall volume at a sufficient volume level. For this reason, some CDs that have a loud overall volume may sound distorted when played back through the amp's speakers or attached headphones at a high level. If this happens, please adjust the **SIDE VOLUME** to stop the CD sound from distorting.

### ⑩ LINE IN stereo mini jack

Connect an external line level (-20 dBu) signal from a synthesizer, guitar preamp, MD player or other device. The signal from the external device is output through the side speakers and its volume is controlled by the **SIDE VOLUME knob**.

### ⑪ PHONES jack

Connect standard stereo headphones to this 1/4" jack to listen to CDs or practice alone.

Outputs the mix of **CENTER VOLUME** and **SIDE VOLUME** signals along with the input signal from the **LINE IN** jack.

#### NOTE

When the **PHONES** jack is in use, the GA-30CD will not output sound from its speakers.

### ⑫ POWER switch

Press to turn the power ON and OFF.

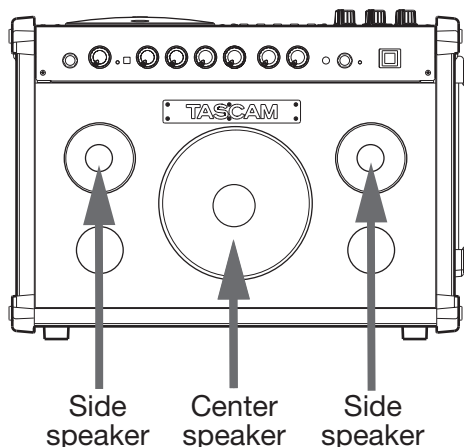



## 2 – Part names and functions

### Top Panel

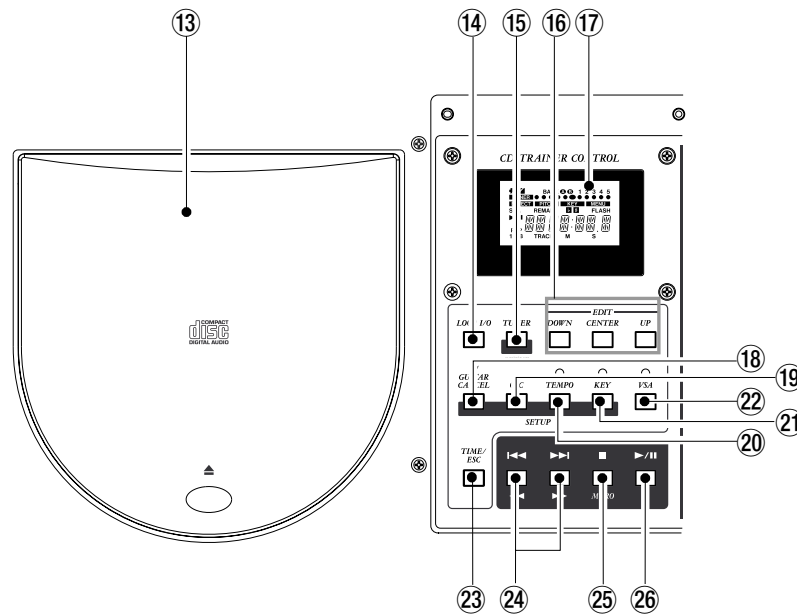

### CD Trainer section

In addition to standard CD player functions, the CD Trainer also has a tuner, a metronome, an oscillator and other features.

#### 13 CD player cover

Lightly press the ▲ mark at the front of the cover to open the player.

#### 14 LOOP I/O key

Use for loop playback.

Press this key to set the loop IN point (starting point) for the currently playing or paused CD. Press this key again to set the OUT point (ending point) and start loop playback automatically.

When IN and OUT points are set, press and hold this key to turn loop playback between the IN and OUT points ON and OFF.

When IN and OUT points are not set, press and hold this key to turn single track or all track repeat ON and OFF. (See “Repeat playback of a selected loop” and “All track or single track repeat playback” on page 16.)

#### 15 TUNER/SETUP key

Press this key to turn the tuner ON and OFF. Make detailed tuner settings using the Setup menu. (See “Using the tuner” on page 18.)

Press and hold this key to open the Setup menu to adjust the time display mode as well as other functions, including tuner settings. Once in the Setup menu, press this key to cycle through setting items. (See the “Changing settings” chapter on page 19.)

#### 16 Setting adjustment keys

Use the three setting change keys to adjust settings.

**DOWN:** Reduce values, flatten the pitch or shift the stereo position to the left.

**CENTER:** Restore the default value, cancel pitch changes or reset the stereo position to the center.

**UP:** Increase values, sharpen the pitch or shift the stereo position to the right.

#### 17 CD Trainer LCD

Shows information about CD playback, etc.

#### 18 GUITAR CANCEL key

Press this key to turn Guitar Cancel ON and OFF. The indicator lights when ON and blinks when in setup mode. Press and hold this key to open the Guitar Cancel setting menu. In this menu, press this key to cycle through setting items. (See “Canceling guitar sounds” on page 17.)

#### 19 OSC key

Press this key to start the oscillator and output an adjustable pitch signal from the side speakers. (See “Using the oscillator” on page 18.)

Press and hold this key to access the Calibration menu and set the standard tuning frequency. (See “Calibrating the tuning frequency” on page 18.)

## 2 – Part names and functions

### 20 TEMPO key

Press this key to turn tempo control ON and OFF. The indicator above the key lights when ON and blinks when settings are being adjusted. Press and hold this key to open the Tempo setting menu. (See “Setting the tempo” on page 16.)

### 21 KEY key

Press this key to turn key adjustment ON and OFF. The indicator above the key lights when ON and blinks when settings are being adjusted. Press and hold this key to enter the Key setting menu. (See “Adjusting the key” on page 17.)

### 22 VSA key

Press this key to activate Variable Speed Audition (VSA). The indicator above the key lights when ON. When ON, VSA keeps the original pitch of the music even when the tempo is changed.

### 23 TIME/ESC key

When a time is displayed, press this key to change the time display mode.

When using a menu, press this key to return to the time display.

### 24 Track skip and search keys (◀◀/◀, ▶/▶▶)

Press ◀◀/◀ and ▶/▶▶ during CD playback to skip to previous or later tracks.

Press these keys when playback is stopped to select a track to play. (Press **PLAY** (▶) to start playback.)

To fast forward during CD playback, press and hold ▶/▶▶. To rewind, press and hold ◀◀/◀.

Fast-forward and rewind speed gradually increases as long as the key is held down.

### 25 STOP (■)/MTRO key

Press to stop CD playback. Press and hold this key to open the Metronome menu. (See “Using the metronome” on page 18.)

### 26 PLAY/PAUSE key (▶/||)

Press to start playback of a stopped or paused CD or pause a playing CD.

## Effects Section

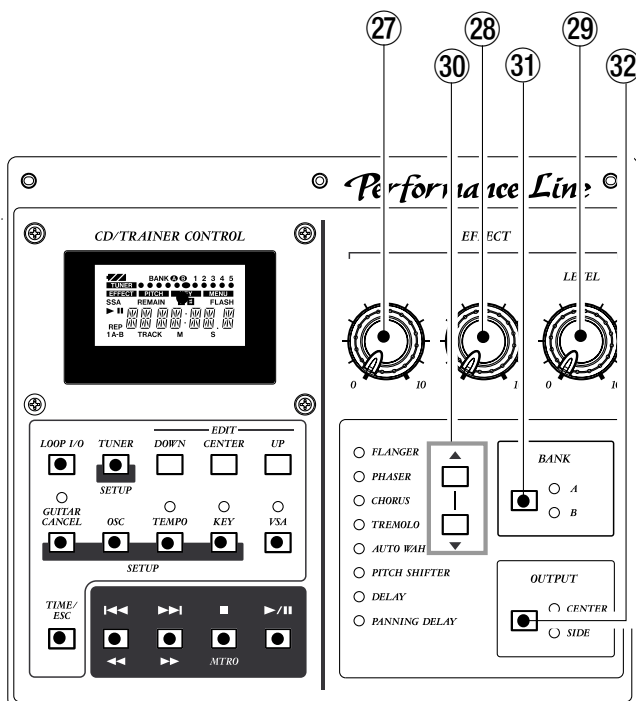

### 27 EFFECT Knob 1

Adjust the first parameter of the selected effect. (See “Using effects” on page 14.)

### 28 EFFECT Knob 2

Adjust the second parameter of the selected effect. (See “Using effects” on page 14.)

### 29 EFFECT LEVEL Knob

Adjust the amount of the effect or the feedback level of the selected effect.

### 30 Effect selection keys (▲, ▼)

Use these to select one of the effects – delay, panning delay, flanger, phaser, chorus, tremolo, auto-wah or pitch shifter. The indicator lights next to the selected effect. When no effect is selected, no indicators light.

### 31 Bank selection key

Select from the effects preset banks. (See “Changing banks” on page 15.)

The indicator lights next to the selected bank.

### 32 OUTPUT key

Press this key to select the effect signal output – the center speaker, the side speakers or all three speakers. Each time you press this key, the output destination setting changes and one or both of the indicators (**CENTER**, **SIDE**) lights to show the selected speakers.

## 2 – Part names and functions

### Rear panel

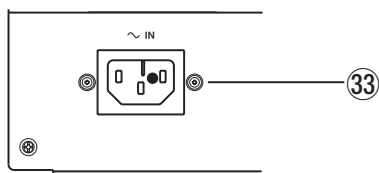

#### ③③ ~ IN

Use the supplied power cord to connect the amp to an AC power outlet. Confirm that the voltage matches that marked on the rear panel of your GA-30CD amp.

### CD Trainer LCD

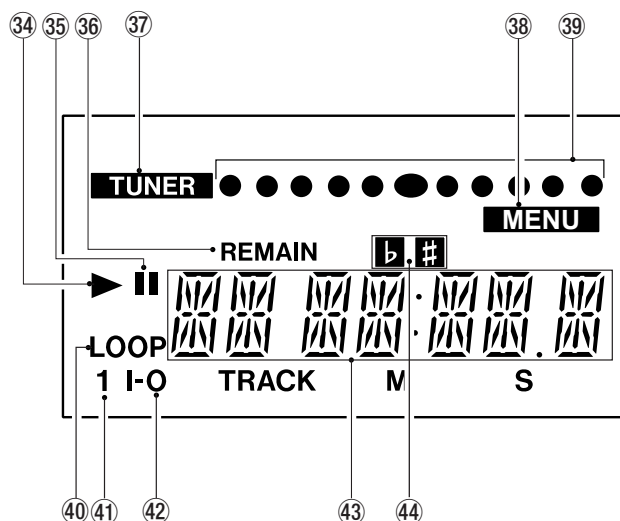

#### ③④ PLAY indicator

Appears during playback.

#### ③⑤ PAUSE indicator

Appears when playback is paused.

#### ③⑥ REMAIN indicator

When no track number appears, this indicates that the remaining time of the entire CD is being shown on the time display. When the track number also appears, this indicates that the remaining time of the currently playing track is being shown. (See “Changing the time display mode” on page 16.)

#### ③⑦ TUNER indicator

Appears when the tuner is in use. (See “Using the tuner” on page 18.)

#### ③⑧ SET UP/MENU indicator

Blinks when the Setup menu is active. (See “Changing settings” on page 19.)

#### NOTE

US models show the indicator **MENU** in this position while European models show the indicator **SETUP**. The function is the same.

#### ③⑨ Tuning meter

Shows pitch during tuning. The center is the correct pitch. The more the indicator lights to the left, the flatter the pitch and the more it lights to the right the sharper the pitch.

#### ④① LOOP indicator

Appears when set to loop playback (ALL/SGL). (See “Repeat playback of a selected loop” on page 16.)

#### ④② 1

Appears when set to single (SGL) repeat playback.

#### ④③ I-O

Blinks when the loop repeat IN point is set and lights when the OUT point is set.

#### ④④ Track number/time display

Shows the currently selected track number (above **TRACK**) and time during playback in minutes (**M**) and seconds (**S**). Also provides information when making various settings.

#### ④⑤ #, b

Shows pitch when key adjustment is ON.

#### NOTE

Some models show these symbols as white on a black background. The function is the same.

## 3 – Connections

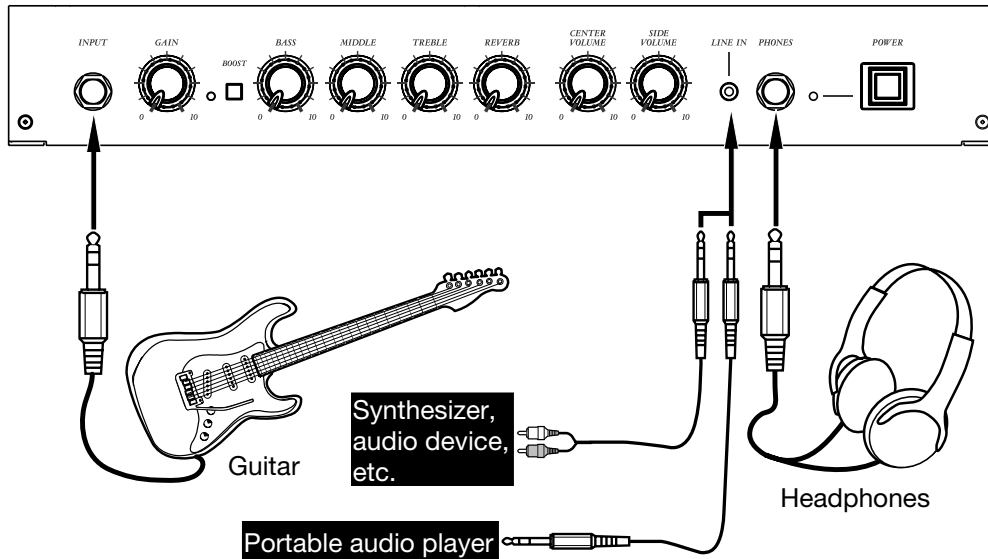

---

### Guitar connection

Connect a guitar to the **INPUT** jack.

Turn the **CENTER VOLUME** and **SIDE VOLUME** knobs to 0 position before connecting.

---

### Headphones connection

Connect stereo headphones to the **PHONES** jack to listen through headphones. Connection to the **PHONES** jack mutes the GA-30CD speakers.

---

### External sound source connection

Connect a synthesizer, audio equipment or other device to the **LINE IN** jack to output its sound through the GA-30CD's speakers. The external sound source signal is sent to the side speakers and the **SIDE VOLUME** knob adjusts its volume.

#### **WARNING**

*Be careful when attaching external sound sources, as very loud signals, especially at low frequencies, may damage the GA-30CD's speakers or permanently harm your hearing.*

## 4 – Using the guitar amp

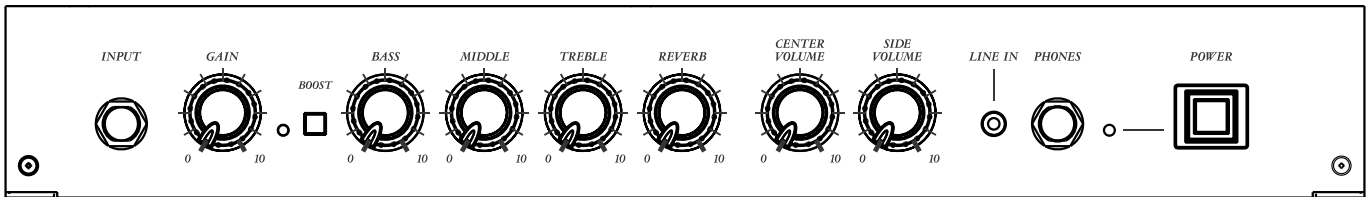

### Adjusting the volume and tone quality

The GA-30CD has a built-in boost circuit for creating distorted sounds. Push the **BOOST** switch to turn this circuit ON. The indicator to the left of the switch lights when it is active.

When the **BOOST** switch is OFF, the guitar input signal is output as an undistorted sound.

The **GAIN** knob always adjusts the guitar input volume, but when the **BOOST** switch is ON, this knob also adjusts the amount of distortion.

The **CENTER VOLUME** knob adjusts the total output volume from the 6.5-inch center speaker, including the output of both the guitar amp and any active effect.

Adjust the **BASS**, **MIDDLE** and **TREBLE** knobs to alter the tone quality (frequency characteristics) further.

#### NOTE

*The **CENTER VOLUME** knob adjusts the overall volume of the output signal sent to the center speaker (6.5-inch). If an effect is used, it will be output along with the guitar amp output.*

*The **BASS**, **MIDDLE** and **TREBLE** knobs reduce the levels of frequencies in specific ranges. At 10, a knob does not cut its frequency band at all while at 0, it cuts its band to the maximum effect.*

### Procedures to shape the guitar tone

- 1 Turn the **CENTER VOLUME** and **SIDE VOLUME** knobs down to 0 (all the way to the left).
- 2 Connect a guitar.
- 3 Turn the **BASS**, **MIDDLE** and **TREBLE** knobs to 10 (all the way to the right).
- 4 Turn the **GAIN** knob to the middle (pointing up).
- 5 Turn up the **CENTER VOLUME** gradually while playing the guitar until you reach the desired volume.
- 6 Shape the tone by adjusting the **GAIN**, **BASS**, **MIDDLE** and **TREBLE** knobs and turning the **BOOST** switch ON or OFF.
- 7 Choose an effect (see “Selecting Effects and setting Parameter” on page 14) and adjust the three effect knobs to shape the tone further.
- 8 Adjust the **CENTER VOLUME** and **SIDE VOLUME** knobs as necessary to achieve the volume balance that you desire.

Of course, you can adjust the knobs in any order that you like, but we recommend that you always turn the **GAIN** and **VOLUME** knobs down before starting and before connecting a guitar.

# 5 – Using effects

The GA-30CD has built-in effects (top panel) and reverb (front panel). The guitar signal passes through the preamp, including **GAIN**, **BASS**, **MIDDLE** and **TREBLE** tone adjustments, before being processed by the effects.

## Effects

### Selecting effects and setting parameters

Use the effect selection (**▲**, **▼**) keys to the left of the effect parameter table to choose an effect – delay, panning delay, flanger, phaser, chorus, tremolo, auto-wah, pitch shifter – or turn the effects OFF.

The effect indicators to the left of the effect names show the active effect. No indicators light when the effects are OFF. Use the three **EFFECTS** knobs (**1**, **2** and **LEVEL**) above the effect parameter table to adjust the parameter amounts. Refer to the chart below for details.

### Restoring the factory effect presets

To restore the effects to their factory settings, use the FXRS item in the Setup menu. (See “Initializing effect banks” on page 19 for details.)

## Effect controls

Effect	1	2	LEVEL
FLANGER	<b>SPEED</b> Set modulation frequency (0.1 – 10 Hz).	<b>DEPTH</b> Set modulation depth.	<b>FEEDBACK LEVEL</b> Set feedback level.
PHASER	<b>SPEED</b> Set modulation frequency (0.2 – 20 Hz).	<b>RESONANCE</b> Set resonance amount.	<b>LEVEL</b> Set effect amount.
CHORUS	<b>SPEED</b> Set modulation frequency (0.1 – 10 Hz).	<b>DEPTH</b> Set modulation depth.	<b>LEVEL</b> Set effect amount.
TREMOLO	<b>SPEED</b> Set modulation frequency (0.2 – 20 Hz).	<b>WAVE TYPE</b> Set modulation wave shape. 0 is triangle, center is sin, and 10 is sawtooth.	<b>DEPTH</b> Set effect amount. Set higher to increase modulation amplitude.
AUTO WAH	<b>SENSITIVITY</b> Set Auto Wah sensitivity.	<b>Q</b> Set filter characteristic. Set higher to increase the effect.	Not used. (Automatically set to maximum.)
PITCH SHIFTER	<b>PITCH</b> Set pitch shift amount up to $\pm 1$ octave. The center position is 0.	<b>FINE</b> Set pitch shift amount up to $\pm 50$ cents. The center position is 0.	<b>LEVEL</b> Set effect amount.
DELAY	<b>DELAY TIME</b> Set delay time (10 ms – 1.1 sec).	<b>FEEDBACK LEVEL</b> Set feedback level.	<b>LEVEL</b> Set effect amount.
PANNING DELAY	<b>DELAY TIME</b> Set delay time (10 ms – 1.1 sec). Sent to L and R side speakers alternately.	<b>FEEDBACK LEVEL</b> Set feedback level.	<b>LEVEL</b> Set effect amount.

---

## Choosing the output

You can choose the speaker(s) that output the effect signal. Press **OUTPUT** to cycle through the settings. Either or both the **CENTER** and **SIDE** indicators light according to the setting. However, the side speakers cannot be selected for the Auto-wah effect.

**CENTER:** Effect signal is output by the center speaker along with the dry guitar signal (standard setting).

**SIDE:** Effect signal is output by the side speakers. Sending the dry guitar signal and the effect signal to different speakers can create a unique spacious sound.

**CENTER + SIDE:** The effect is output by the center speaker and the side speakers. Set the balance using the **SIDE** and **CENTER VOLUME** knobs.

### NOTE

*Output speaker selection greatly changes the sound. Adjust the tone quality as you switch between output settings to achieve a sound you like.*

---

## Reverb

The GA-30CD's built-in reverb simulates a classic guitar amp spring reverb.

Use the **REVERB** knob to adjust the reverb signal output level.

The knob position always determines the reverb setting. It is not saved with banks.

---

## Effect banks

The GA-30CD has 2 banks (A and B) to store effects and reverb settings.

Bank settings are stored in built-in memory each time a parameter is adjusted or the bank is changed.

When the unit is new, the A bank is set to **CHORUS** and the B bank is set to **DELAY**. If you use the **FXRS** item in the Setup menu, these effects and their settings will be reset. (See "Initializing effect banks" on page 19 for details.)

---

## Changing banks

Use the bank selection key to change between banks A and B. You can recall different types of effects by switching banks.

The indicator lights next to the active bank (A or B).

The effect settings made with the knobs are automatically saved to the active bank, so no special operation is necessary to save your changes.

The effect settings of a bank match the previously saved state when recalled, so the knob positions may not show the current parameter values. In such cases, moving a knob will immediately cause the knob setting to effect the parameter.

### NOTE

*When a bank is recalled, the indicator will show the selected bank, but the position of the effect knobs (1, 2 and **LEVEL**) will not change, therefore they will not match the bank settings. Move any knob to change the associated parameter value to the knob's current position.*



# 6 – Using the CD trainer

## Playing CDs

- 1 Press **▲** at the front of the CD player cover lightly to open it.
- 2 Place a CD in the tray and close the cover.
- 3 Press **▶/||** to start playback.  
Press **■** to stop playback.  
Press **▶/||** to pause playback.

Use **◀◀(◀◀)** and **▶▶(▶▶)** to skip between tracks and search through them. Press briefly to skip to another track or press and hold to search a track.

### NOTE

*Opening the cover stops playback.*

## Changing the time display mode

Press **TIME/ESC** to cycle through the three time display modes to the right.

- Elapsed time (track number, time)

- Remaining track time (**REMAIN** indicator, track number, time)
- Remaining disc time (**REMAIN** indicator, time)

## Repeat playback of a selected loop

Follow these procedures to repeat playback of a selected part of a disc (loop playback).

- 1 Press **LOOP I/O** when a CD is playing or paused to set the loop **IN** point (starting point). The **I-0** indicator on the LCD blinks.

- 2 Press **LOOP I/O** again to set the loop ending point and start loop playback between the **IN** and **OUT** points. The **I-0** indicator appears on the LCD during loop playback.

## Stopping loop playback

Press **LOOP I/O** to stop loop playback, resume normal playback and erase the **IN** and **OUT** point settings. To retain the loop **IN** and **OUT** points, press and hold **LOOP I/O** when turning loop playback **ON** and **OFF**.

## All track or single track repeat playback

Repeat playback of the current track or all tracks on the disc is possible.

- 1 In the **Setup** menu, use the **PLAY** item to select all track loop (**ALL**) or single track loop (**SGL**). The default setting is **ALL**. (See "Changing settings" on page 19.)
- 2 Press and hold **LOOP I/O** to start all track or single track loop playback according to the above **PLAY** setting.

- Press **■** to stop playback.

- Press and hold **LOOP I/O** to stop loop playback and resume normal playback.

### NOTE

*Pressing **LOOP I/O** when **IN** and **OUT** points are set will erase these settings.*

## Setting the tempo

Follow these procedures to set the tempo.

- 1 Press and hold **TEMPO** to open the tempo setting screen opens. The indicator above the **TEMPO** key blinks.
- 2 Use the **DOWN**, **CENTER** and **UP** keys to adjust the tempo.
- 3 Press **TIME/ESC** after completing the setting to return to the time display.

Changing the tempo value from 0 turns tempo control **ON**, and playback speed adjusts to the new tempo. The indicator above the **TEMPO** key lights when this function is **ON** and set at a value other than 0.

The tempo setting amount depends on whether Variable Speed Audition (**VSA**) is **ON** or **OFF**. (See "Changing tempo without changing key" on page 17.)

When **VSA** is **ON**, the possible settings are: -50, -32, -16, -12, -8, -4, 0, +4, +8, +12, +16 (%).

When **VSA** is **OFF**, adjustment can be made freely between -50% and +16%.

### NOTE

*If the tempo value was set while **VSA** is **OFF**, turning **VSA ON** changes the tempo value to the nearest of the above settings.*

## 6 – Using the CD trainer

### Turning tempo control ON and OFF

Press **TEMPO** to turn tempo control ON and OFF.

The set tempo value is stored even when tempo control

is OFF. The next time it is turned ON, playback will occur at the last set tempo value.

### Changing tempo without changing key

Turn ON the GA-30CD's Variable Speed Audition (VSA) function to change the tempo of a track without changing its key.

Press the **VSA** key to turn this function ON and OFF. When it is ON, the indicator above the **VSA** key lights.

Turning VSA ON and OFF also turns tempo control ON and OFF.

#### NOTE

*When the tempo is changed widely, the sound may be heard as double.*

### Adjusting the key

- 1 Press and hold **KEY** to show the key setting screen. The indicator above the **KEY** key blinks, and the current setting with **KEY** indicator appear on the LCD.
- 2 Change the key using the **DOWN**, **CENTER** and **UP** keys. The key can be raised or lowered up to 6 semitones (♭6–#6).  
**Changing the key (to any value besides 0) turns key adjustment ON and playback changes accordingly. The indicator above the KEY key lights when this function is ON.**
- 3 Press **KEY** again to make fine pitch adjustments.

- 4 Use the **DOWN**, **CENTER** and **UP** keys to adjust the pitch in cents (1/100 semitone).
- 5 Press **TIME/ESC** to finish making the setting and return to the menu.

#### NOTE

*When the key is changed widely, the sound may be heard as it is trembling.*

*Even if no key change is made in step 2 above (the value is set to 0), fine adjustment in step 3 turns key adjustment ON.*

### Turning key adjustment ON and OFF

Press **KEY** to turn key adjustment ON and OFF. The key setting value is retained even when turned OFF.

When key adjustment is turned ON again, the set key value affects playback.

### Canceling guitar sounds

Use the Guitar Cancel function to cut the sound of recorded guitars during CD playback.

Press **GUITAR CANCEL** to turn the Guitar Cancel function ON and OFF. The indicator above the **GUITAR CANCEL** key lights when this function is ON.

#### NOTE

*Depends on the condition of recorded audio, the Guitar Cancel function may not be able to fully cancel guitar sounds. In such case, as well as other instruments' sounds, setting the cancellation effect may help to reduce the guitar sounds (see "Setting the Guitar Cancel function" below).*

### Setting the Guitar Cancel function

Use these procedures to adjust the stereo region and frequency range of the cancellation effect.

- 1 Press and hold the **GUITAR CANCEL** key. **PART** appears on the LCD.
- 2 While listening to the playback, use the **DOWN**, **CENTER** and **UP** keys, to select the stereo region (L10 – R10) that reduces the guitar sound the most.
- 3 Press the **GUITAR CANCEL** key again. **RNGE** appears on the LCD.
- 4 While listening to the playback, use the **DOWN**, **CENTER** and **UP** keys to select the frequency range (MID or ALL) that reduces the guitar sound

**most effectively. ALL will cut out high and low sounds from other instruments in the same stereo position.**

- 5 Press **TIME/ESC** to finish making the setting and return to the menu.

#### NOTE

*The values set here are retained even when the Guitar Cancel function is turned OFF. When it is turned ON again, the previously made settings will be applied to playback again.*

*The Guitar Cancel function can not be used with the audio recorded in mono, also this function may not be effective to the guitar sounds with many effects.*

# 7 – Tuner, oscillator and metronome

## Using the tuner

The GA-30CD has a built-in guitar tuner with 2 modes –chromatic mode and guitar mode. In chromatic mode (the default setting), the GA-30CD automatically detects the input signal pitch. Guitar mode helps you tune

strings to standard guitar tuning. (See the “Changing settings” chapter on page 19 for details on setting the tuner mode and sound output.)

## Calibrating the tuning frequency

The standard tuning frequency (A4) can be adjusted.

- 1 Press and hold **OSC** to start calibration. **CAL** appears on the LCD.
- 2 Use the **DOWN** and **UP** keys to adjust the standard tuning frequency from 435 Hz to 445 Hz. Press

the **CENTER** key to restore the default setting of 440 Hz.

- 3 Press **OSC** or **ESC** to finish calibration and return to time display.

## Tuning in chromatic mode

- 1 Connect a guitar and press **TUNER**. **TUNER** appears on the LCD along with the tuning meter shown to the right. Play the guitar string you want to tune. The LCD will show the name of the closest note.
- 2 Tune the guitar roughly until the note that you want to tune to appears on the LCD.
- 3 Tune until only the meter's large central dot lights. If the pitch is too low (flat), the dots left of the center light. If the pitch is too high (sharp), the

dots right of the center light. More dots light as the string goes further out of tune.

- 4 When finished tuning, press **TIME/ESC** to return to the time display.



## Tuning in guitar mode

- 1 Connect a guitar and press **TUNER**. **TUNER** appears on the LCD along with the tuning meter. **6E** appears on the right side of the LCD, indicating that it is set to tune the 6th string.
- 2 Use the **DOWN** and **UP** keys to choose the string (**1E**, **2B**, **3G**, **4D**, **5A** or **6E**) you want to tune.

- 3 Tune the string until only the large dot at the center of the meter lights.
- 4 When finished tuning, press **TIME/ESC** to return to the time display.

## Using the oscillator

Use the built-in oscillator to output a sine wave through the speakers. This wave can be set to any note in a 3-octave range between C3 and B5.

- 1 Press the **OSC** key. **OSC** appears on the LCD and the oscillator starts.
- 2 Use the **DOWN** and **UP** keys to set the generated pitch. The default setting is **A4**. The selected pitch (**C3–B5**) appears on the screen.

- 3 Press **TIME/ESC** to finish making the setting and return to the time display.

Use the **SIDE VOLUME** knob to adjust the level of the oscillator.

### NOTE

The oscillator's standard tuning frequency depends on the calibration setting. (See “Calibrating the tuning frequency” above.)

## Using the metronome

Follow these procedures to set the tempo and the number of beats per measure for the GA-30CD's built-in metronome.

- 1 Press and hold **■/MTRO** to open the Metronome menu. As the metronome is still **OFF**, **METRO: OFF** is shown on the LCD.
- 2 Use the **DOWN** and **UP** keys to adjust the tempo in a range of 40–220 bpm (beats per minute). Adjusting the tempo turns the metronome **ON**.

- 3 Press **■/MTRO** briefly. Use the **DOWN** and **UP** keys to adjust the number of beats per measure between 2 and 6.

- 4 Press **TIME/ESC** when finished using the metronome to return to the time display.

Use the **SIDE VOLUME** knob to adjust the level of the metronome.

## 8 – Changing settings

Change the following GA-30CD settings by pressing and holding **TUNER/SETUP** to open the **SETUP (MENU)** screen.

- Playback mode selection
- Tuner mode selection
- Tuner speaker output ON and OFF
- Initialize effect bank settings

Press **TUNER/SETUP** again to cycle through the setting items. Use the **DOWN** and **UP** keys to adjust the values for each item and the **CENTER** key to restore the default setting.

Press **TIME/ESC** to finish making settings and close the **SETUP (MENU)** screen.

These settings are saved automatically.

---

### Playback mode selection

---

Use the **PLAY** item to select whether all tracks on a disc (**ALL**) are played or only the currently selected track (**SGL**) is played when using the loop playback function. The default setting is **ALL**.

---

### Tuner settings

---

Use the **TMOD** item to set the tuner mode. (See “Using the tuner” on page 18.)

**CHR**: chromatic mode (default setting)

**GTR**: guitar mode

---

### Tuner speaker output

---

Use the **TOUT** item to set whether or not the guitar signal outputs through the center speaker when the tuner is turned on. The default setting is **OFF**.

---

### Initializing effect banks

---

Use the **FXRS** item to restore all effect banks to their factory settings.

**NO** appears on the LCD when you choose the **FXRS** item. Press the **DOWN** or **UP** key and **YES** will appear. Press and hold the **CENTER** key to restore all effect banks to their factory settings.

After initialization is complete, **DONE** appears on the LCD and the time display reappears.

#### **CAUTION**

*Initializing effect banks erases all the preset bank settings that have been made. Use this function only if you are sure that you want to overwrite these settings with the factory defaults.*

# 9 – Specifications

## Guitar amplifier

### Rated output

CENTER	15 W (RMS into 8 $\Omega$ )
SIDE	7.5 W (RMS into 8 $\Omega$ ) x 2

### Speakers

CENTER	6.5-inch
SIDE	3-inch x 2

### Inputs

GUITAR INPUT	Unbalanced 1/4" (6.3 mm) jack
Standard input level	-10 dBu
Input impedance	1.0 M $\Omega$
LINE INPUTS	1/8" (3.5 mm) stereo minijack
Standard input level	-20 dBu
Input impedance	>7 k $\Omega$

### Output

HEADPHONES	1/4" (6.3 mm) stereo phone jack
Output	> 20 mW + 20 mW (into 32 $\Omega$ )

### Built-in effects (mono/stereo)

Types	Delay, panning delay, flanger, phaser, chorus, tremolo, auto-wah, pitch shifter, reverb
Presets	2

## CD Trainer

Playable discs	8-cm/12-cm CD, CD-R, CD-RW (audio CDs only)
DA	16-bit
Digital signal processing	32-bit

### Playback characteristics

Frequency characteristics	20 – 20,000 Hz +1.0/-3.0 dB
Dynamic range	> 80 dB
S/N ratio	> 80 dB
THD	< 0.1%

## Physical

Power	USA/Canada 120 VAC, 60 Hz; UK/Europe 230 VAC, 50 Hz; Australia 240 VAC, 50 Hz
Power consumption	36 W
Dimensions (W x H x D)	484 x 352 x 260 mm (19.1 x 13.9 x 10.2 inches)
Weight	13.8 kg (30.4 lbs.)

# 9 – Specifications

## Block diagram

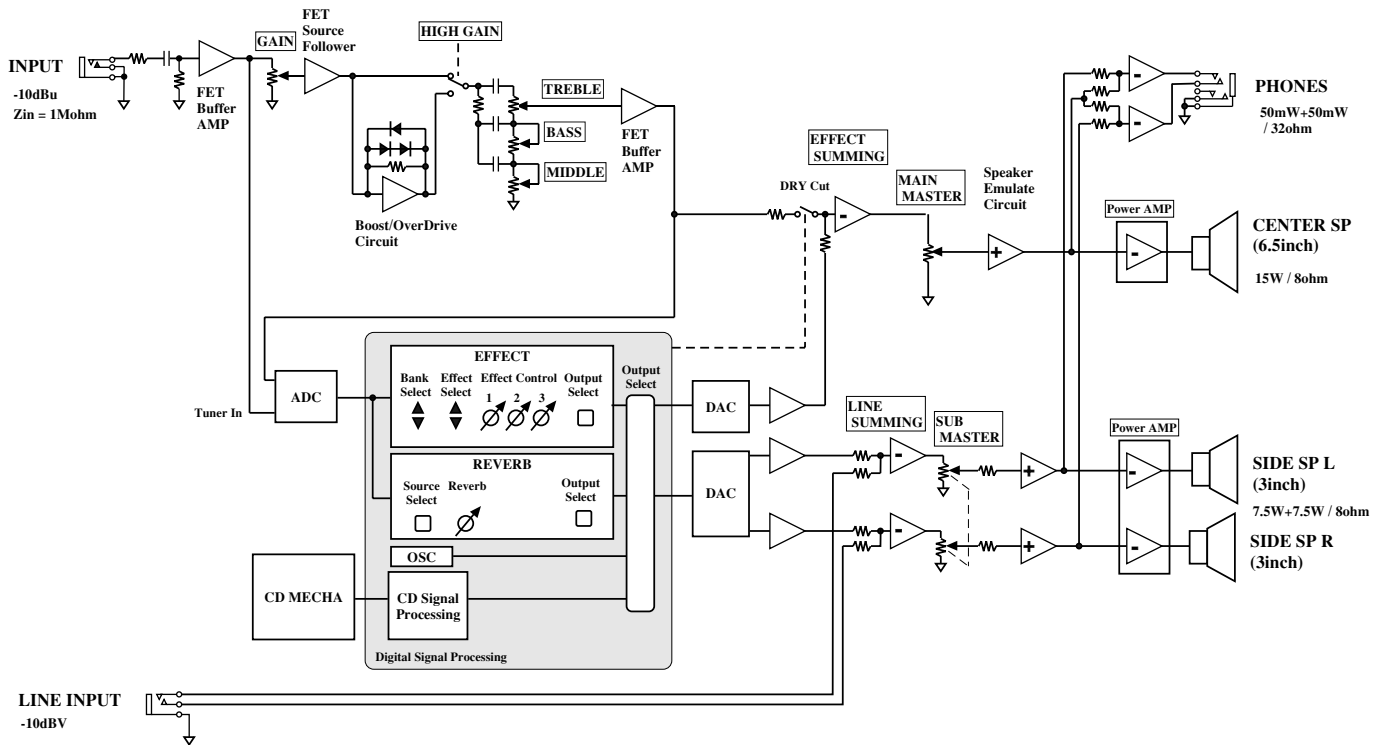

## Dimensional drawing

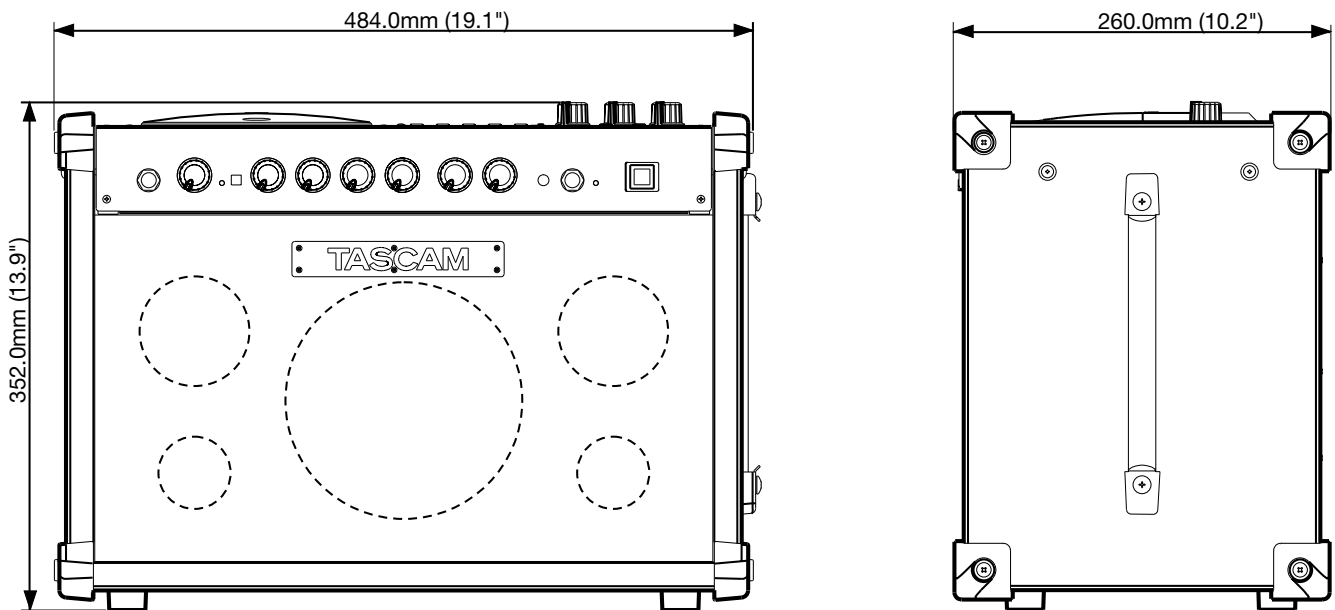







# **TASCAM**

**TEAC Professional Division**

# **GA-30CD**

## **TEAC CORPORATION**

Phone: +81-422-52-5082  
3-7-3 Nakacho, Musashino-shi, Tokyo 180-8550 Japan

[www.tascam.com](http://www.tascam.com)

---

## **TEAC AMERICA, INC.**

Phone: +1-323-726-0303  
7733 Telegraph Road, Montebello, California 90640 USA

[www.tascam.com](http://www.tascam.com)

---

## **TEAC CANADA LTD.**

Phone: +1905-890-8008 Facsimile: +1905-890-9888  
5939 Wallace Street, Mississauga, Ontario L4Z 1Z8, Canada

[www.tascam.com](http://www.tascam.com)

---

## **TEAC MEXICO, S.A. De C.V**

Phone: +52-555-581-5500  
Campesinos No. 184, Colonia Granjes Esmeralda, Delegacion Iztapalapa CP 09810 Mexico DF

[www.tascam.com](http://www.tascam.com)

---

## **TEAC UK LIMITED**

Phone: +44-8451-302511  
Unit 19 & 20, The Courtyards, Hatters Lane Watford, Hertfordshire WD18 8TE U.K.

[www.tascam.co.uk](http://www.tascam.co.uk)

---

## **TEAC EUROPE GmbH**

Phone: +49-611-71580  
Bahnstrasse 12, 65205 Wiesbaden-Erbenheim, Germany

[www.tascam.de](http://www.tascam.de)

---

Printed in China

## Free Manuals Download Website

<http://myh66.com>

<http://usermanuals.us>

<http://www.somanuals.com>

<http://www.4manuals.cc>

<http://www.manual-lib.com>

<http://www.404manual.com>

<http://www.luxmanual.com>

<http://aubethermostatmanual.com>

Golf course search by state

<http://golfingnear.com>

Email search by domain

<http://emailbydomain.com>

Auto manuals search

<http://auto.somanuals.com>

TV manuals search

<http://tv.somanuals.com>