

TASCAM

TEAC Professional Division

PA-30

Dual Power Amplifier

OWNER'S MANUAL

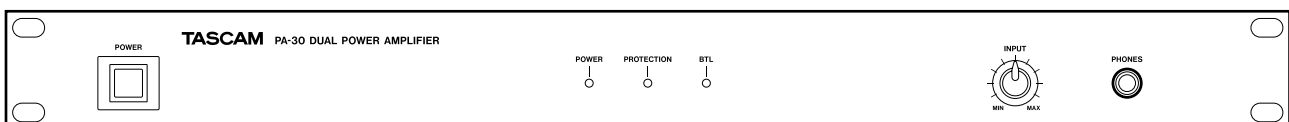

Introduction

The TASCAM PA-30 is a high-performance professional audio power amplifier for nearfield studio monitoring and low-level sound reinforcement. In stereo mode, the PA-30 delivers 30 watts per channel continuously into an 8 ohm load - with no more than 0.05% total harmonic distortion. For applications requiring higher output power, the unit may be operated in BTL (Balanced Transformerless) mode - also known as 'bridged' operation - and will deliver a full 60 watts continuously into 8 ohms (see the 'BTL Operation' section of this manual on page 9). In either mode, it exhibits a flat frequency response characteristic from 20 Hz to 20 kHz (+0, -1dB), with very low residual hum and noise.

For maximum flexibility, the PA-30 is equipped with both XLR-type balanced and RCA-type unbalanced input connectors. These accommodate nominal input signal operating levels of +4 dBm and -10 dBV, respectively essentially eliminating the necessity for external compensating pads or gain stages. A single, continuously variable INPUT LEVEL control attenuates input signals so the unit's sensitivity can be calibrated to the gain structure of the source equipment. The PA-30 is designed and built to provide years of trouble-free service with little or no maintenance. Its well built power transformer easily handles continuous full-power operation, and all power semiconductor circuits are mounted on a large convection-cooled heatsink.

Multiple resettable electronic protection circuits guard against destructive turn-on transients, output overload, DC offsets and output shorts.

While the PA-30 is almost indestructible, it has been engineered to be easy to service. Like all TASCAM professional products, it is backed by a worldwide network of TASCAM dealers and TEAC authorized TASCAM service centers.

Connection and operation of the PA-30 is simple and straightforward. This manual presents a detailed description of the unit's features, along with basic connection instructions and specifications. Please take a few moments to study it before connecting and operating your PA-30 Power Amplifier.

TABLE OF CONTENTS

Introduction.....	2
Important Safety Instructions	3
Summary of Operating Precautions.....	4
Features.....	5
Connection & Installation.....	7
BTL Operation.....	9
Specifications.....	10



CAUTION
RISK OF ELECTRIC SHOCK
DO NOT OPEN



CAUTION: TO REDUCE THE RISK OF ELECTRIC SHOCK, DO NOT REMOVE COVER (OR BACK). NO USER-SERVICEABLE PARTS INSIDE. REFER SERVICING TO QUALIFIED SERVICE PERSONNEL.



The lightning flash with arrowhead symbol, within an equilateral triangle, is intended to alert the user to the presence of uninsulated "dangerous voltage" within the product's enclosure that may be of sufficient magnitude to constitute a risk of electric shock to persons.



The exclamation point within an equilateral triangle is intended to alert the user to the presence of important operating and maintenance (servicing) instructions in the literature accompanying the appliance.

This appliance has a serial number located on the rear panel. Please record the model number and serial number and retain them for your records.

Model number _____
Serial number _____

WARNING: TO PREVENT FIRE OR SHOCK HAZARD, DO NOT EXPOSE THIS APPLIANCE TO RAIN OR MOISTURE.

IMPORTANT SAFETY INSTRUCTIONS

- 1) Read these instructions.
- 2) Keep these instructions.
- 3) Heed all warnings.
- 4) Follow all instructions.
- 5) Do not use this apparatus near water.
- 6) Clean only with dry cloth.
- 7) Do not block any ventilation openings. Install in accordance with the manufacturer's instructions.
- 8) Do not install near any heat sources such as radiators, heat registers, stoves, or other apparatus (including amplifiers) that produce heat.
- 9) Do not defeat the safety purpose of the polarized or grounding-type plug. A polarized plug has two blades with one wider than the other. A grounding type plug has two blades and a third grounding prong. The wide blade or the third prong are provided for your safety. If the provided plug does not fit into your outlet, consult an electrician for replacement of the obsolete outlet.
- 10) Protect the power cord from being walked on or pinched particularly at plugs, convenience receptacles, and the point where they exit from the apparatus.
- 11) Only use attachments/accessories specified by the manufacturer.
- 12) Use only with the cart, stand, tripod, bracket, or table specified by the manufacturer, or sold with the apparatus. When a cart is used, use caution when moving the cart/apparatus combination to avoid injury from tip-over.



- 13) Unplug this apparatus during lightning storms or when unused for long periods of time.
- 14) Refer all servicing to qualified service personnel. Servicing is required when the apparatus has been damaged in any way, such as power-supply cord or plug is damaged, liquid has been spilled or objects have fallen into the apparatus, the apparatus has been exposed to rain or moisture, does not operate normally, or has been dropped.

- Do not expose this apparatus to drips or splashes.
- Do not place any objects filled with liquids, such as vases, on the apparatus.
- Do not install this apparatus in a confined space such as a book case or similar unit.
- The apparatus draws nominal non-operating power from the AC outlet with its POWER switch in the off position.

Summary of Operating Precautions

- Do not use the PA-30 if the power cord appears frayed or broken.
- Do not spill liquids into or on the PA-30 chassis. If the chassis becomes wet, allow it to dry thoroughly before reconnecting the unit.
- Allow sufficient space at the top, and bottom of the PA-30 to permit a flow of cooling air. Keep the unit away from radiators or others that produce heat.
- Never connect the PA-30 outputs to a battery, power supply or other voltage source. Do not short the output hot terminals together.
- The minimum allowable load impedance on each PA-30 output is 8 ohms in stereo mode or BTL mode. Connecting loads of lower impedance will result in current limiting and/or activation of the protection circuits.
- Before operating the PA-30, be certain that the MODE switch is set in accordance with the desired operational mode and output connection configuration (see the 'BTL Operation' section of this manual, page 9).
- Any unauthorized internal modification to the PA-30 will invalidate the warranty, and may result in hazardous conditions. Refer all servicing to a TEAC authorized TASCAM service center.
- Connect the PA-30 only to properly wired AC outlets. Make certain that the voltage is correct for the version of the unit that you are using (110 to 120 volts at 60 Hz for domestic USA).

AC Power Connection

The PA-30 requires a reliable source of single-phase power at 110 to 120 volts AC, 60 Hz (domestic US version). It has a two-prong, ungrounded AC cord, and may be connected to either two-prong or three-prong outlets.

If you have any doubt about the wiring of the outlet that you wish to use, it is wise to test it before making connections. Simple plug-in testers are available from a variety of electronics and hardware stores.

If an outlet appears to require repairs, consult a qualified electrician - and *don't use it*. An improperly-wired outlet may present a serious shock hazard. For reference, Figure 1 shows the characteristics of a properly wired US standard three-prong wall outlet.

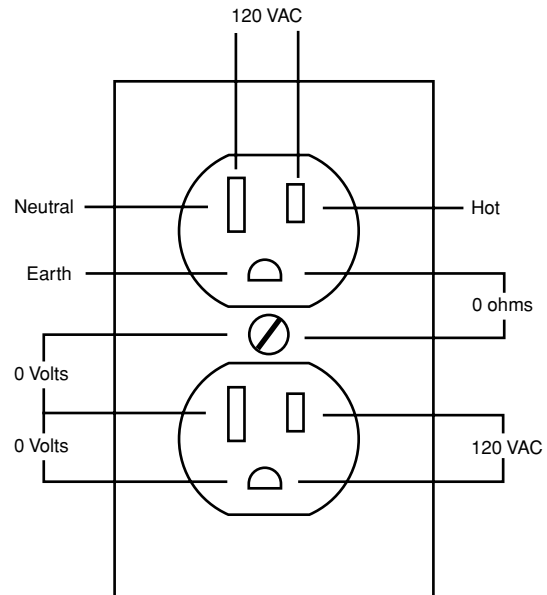

Figure 1. Standard wall Receptacle

Voltage Conversion

Be sure to unplug the power cord from the AC outlet before repositioning the voltage converter switch.

- 1) Locate the voltage selector on the rear panel.
- 2) Using a flat-bladed screwdriver, set to the appropriate 120 V or 230 V position according to your area.

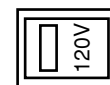

Figure 2. Voltage Selector

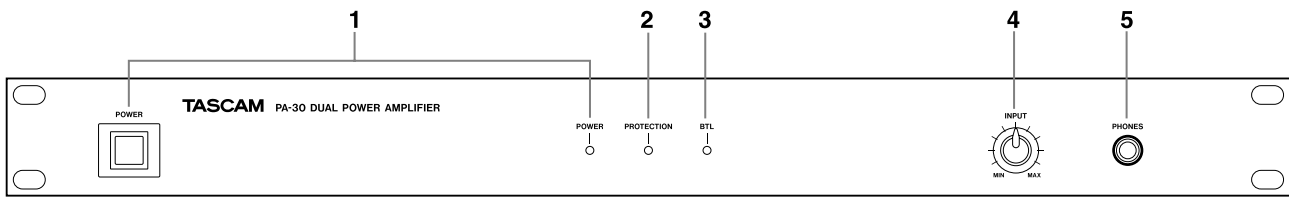

Figure 3. PA-30 FRONT PANEL

1. POWER Switch and Indicator

A two-position rocker-type switch controls power to the unit. Depressing the upper surface of the switch turns the amplifier on; depressing the lower surface turns it off. The green LED Power indicator will light whenever the unit is on and is connected to a properly functioning source of power.

2. PROTECTION Indicator

The red LED Protection indicator remains off whenever the PA-30 is turned on and is operating normally.

If an overload, short circuit, DC offset or other problem triggers the internal electronic protection circuitry, the unit shuts down and the Protection indicator lights. Once the PA-30 is turned off and the fault condition is cleared, the Protection circuit will automatically reset, and normal operation can be resumed (provided that the fault has not damaged the unit).

If the Protection indicator lights when the PA-30 is first switched on, turn the Power switch OFF and recheck all of your connections before resetting power.

3. BTL Indicator

The orange LED BTL indicator will light whenever the MODE switch (on rear panel) is in the 'BTL (MONO)' position.

4. INPUT LEVEL Control

A single rotary variable attenuator sets the input sensitivity of the PA-30 Amplifier. The degree of attenuation varies from zero loss (maximum sensitivity) at the 'MAX' position to infinite loss at the 'MIN' position.

5. PHONES Jack

This Tip/Ring/Sleeve 1/4" phone jack accommodates 8 ohms or higher impedance stereo headphones.

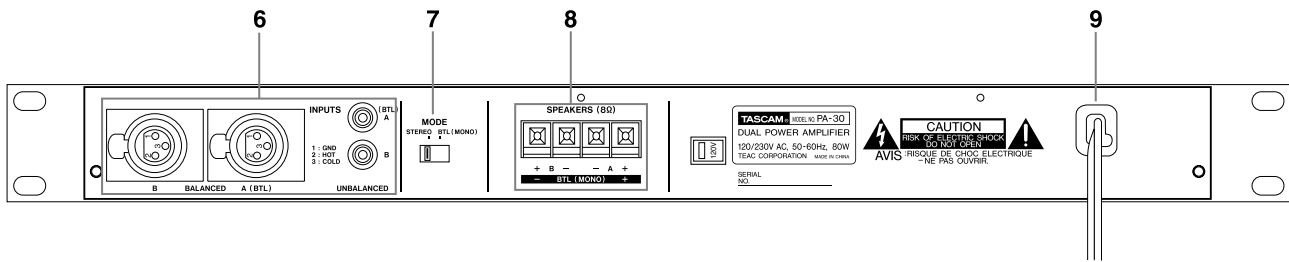

Figure 4. PA-30 REAR PANEL

6. INPUTS (A & B, XLR & RCA Type)

Two input connectors are provided for each channel: one RCA (phono) jack and one XLR-type female connector. Either connector may be used on a given channel, but both connectors for a single channel should not be used simultaneously.

Both inputs present a high impedance, and cause no appreciable loading to source outputs. Input sensitivity is -10 dBV (0.3 volt RMS) at the RCA inputs, and $+1.3$ dBu (0.9 volt RMS) at the XLR inputs, for rated output (with Input Level control at maximum). Pin assignments are as follows:

XLR-type

Pin 1 = common
Pin 2 = 'high'(+)
Pin 3 = 'low'(-)

RCA-type

Shell = common
Tip = 'high'(+)

Virtually any line-level source may be connected to these inputs. (Refer to the 'Connection and Installation' section for further details.)

7. MODE switch

A single two-position slide switch (on rear panel) selects either monophonic BTL (Balanced Transformerless, also known as 'bridged', with switch set to BTL) or stereo operation (with switch set to STEREO).

If the MODE switch is not correctly set, damage to the loudspeakers or to the PA-30 may result. For a complete explanation of use of the MODE switch, consult the section on 'BTL Operation' on page 9 of this manual.

8. SPEAKERS (A & B)

A pair of color-coded locking terminals is provided for output connections to each channel of the PA-30. They will accommodate stripped bare wire, or tinned wire ends. The minimum allowable load impedance for each output is 8 ohms.

The actual output connection configuration will vary depending upon the mode of operation selected and the number and type of loudspeakers used. Please refer to the sections on 'BTL Operation' and 'Output Connections' before making connections to the PA-30 outputs.

9. Mains Power Cord

The inlet for AC power to the PA-30 is a two-prong ungrounded plug (rear panel mounted). The PA-30 requires 120/230 volts AC at 50/60 Hz. It draws 8 watts at idle, and 130 watts at full rated output.

Input Connections

Before making connections to the PA-30 signal inputs, find the nominal output level of your signal source (this information is usually given in the Specifications section of the instruction manual). Equipment operating at -10 dBV should be connected to the RCA (phono) inputs, while $+4$ dBm equipment will operate best if connected to the XLR-type inputs. (Low-level signal such as an electric guitar or phonograph cartridge will require an external preamplifier.)

Components that operate at -10 dBV normally feature either RCA or 1/4-inch phone output connectors, presenting an unbalanced (two-connection) drive. Standard connecting cables and adapters may be used with such equipment. If you are making your own cables, refer to Figure 5 for wiring details.

From Source Equipment

To PA-30 RCA Input

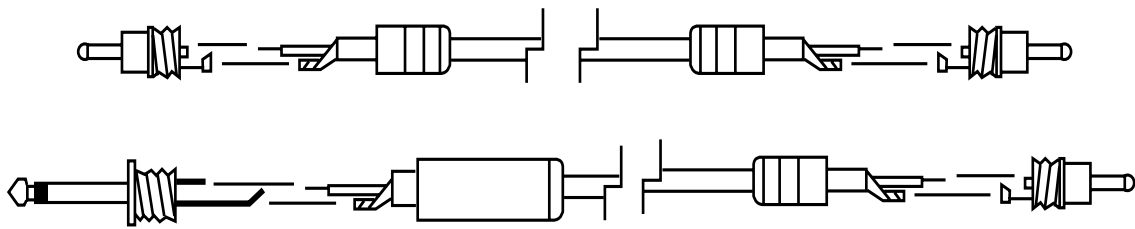

Figure 5. Connections to the PA-30 -10 dBV Input

Professional $+4$ dBm components, on the other hand, may feature either 1/4-inch phone or XLR-type output connectors, presenting either an unbalanced or a balanced drive. In some cases, standard microphone cables may be used for such equipment; in others, special cables or adapters may be required.

Figure 6 shows the recommended wiring configurations for a few standard $+4$ dBm output types. Refer

to this figure when determining the types of cables and adapters to use in connecting to the PA-30 XLR inputs. Take care to observe the polarity conventions indicated; input polarity reversals may cause acoustical phase cancellation, resulting in unnatural sound.

From Source Equipment

To PA-30 XLR Input

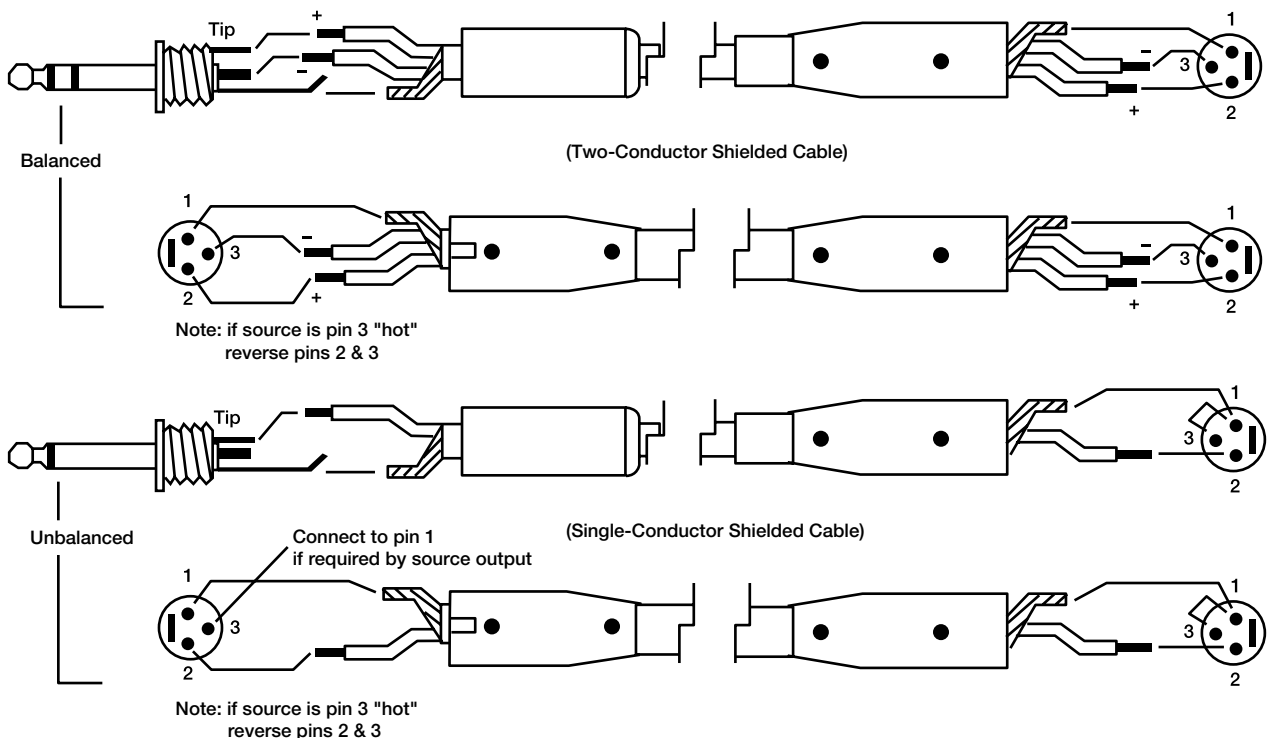

Figure 6. Connections to the PA-30 $+4$ dBm Input

Connection and Installation

Output Connections

Each channel of the PA-30 will drive a minimum load impedance of 8 ohms. Connecting a load of lower impedance will result in current limiting and may trigger the Protection circuits to shut down the amplifier.

Figure 7 shows a normal stereo-mode connection of two individual speakers to the PA-30 outputs. When making loudspeaker connections, always be sure to maintain correct polarity; if you wire the speakers out of phase with one another, you will get acoustical phase cancellations.

There are two basic methods for connecting multiple speakers to a single amplifier output: series connection and parallel connection. Loudspeakers connected in series present a higher net impedance than any single unit alone. Parallel connection, by contrast, lowers the net load impedance. Sometimes, the two methods are

combined to obtain an optimum load impedance. Figure 8 shows what happens to the net load impedance when multiple loudspeakers are connected in various ways. (In all cases, it is assumed that all speakers in a given system have the same impedance.)

Generally, only parallel connection is used in professional audio, for two fundamental reasons. First, if one of the speakers in a parallel system fails, the others will still function. (Remember those old Christmas lights that all went out the minute one bulb failed? They were connected in series.) Second, parallel connection results in a lower net impedance. The closer the load impedance gets to the allowable minimum for the amplifier, the more efficiently is the amplifier's power capability used, since the lower load impedance draws more current from the output stage.

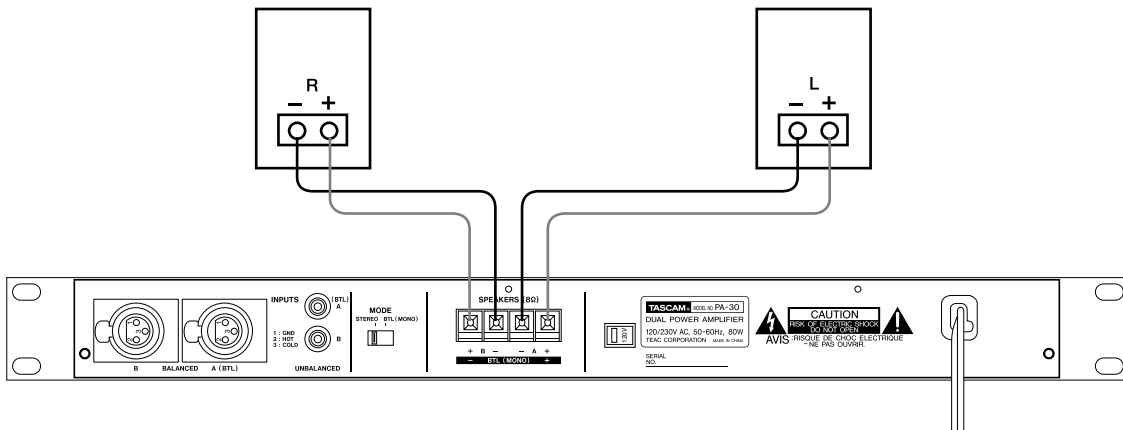

Figure 7. Typical Stereo Output Connection

Each Unit	Two In Series	Three In Series	Four In Series
4 OHMS	8 OHMS	12 OHMS	16 OHMS
8 OHMS	16 OHMS	24 OHMS	32 OHMS
16 OHMS	32 OHMS	48 OHMS	64 OHMS

Each Unit	Two In Parallel	Three In Parallel	Four In Parallel	Four In Series/Parallel
4 OHMS	(2 OHMS)	(1.33 OHMS)	(1 OHM)	(4 OHMS)
8 OHMS	(4 OHMS)	(2.66 OHMS)	(2 OHMS)	8 OHMS
16 OHMS	8 OHMS	(5.33 OHMS)	(4 OHMS)	16 OHMS

Note: Impedances shown in brackets are too low for the amplifier. Do not use three loudspeaker configurations.

Figure 8. Connecting Multiple Loudspeakers

The PA-30 rear panel includes a switch that selects either normal stereo mode or a special mode termed BTL (Balanced Transformerless). The setting of this switch determines the maximum power available to the load from the PA-30, and also decisively affects how the load is connected to the amplifier. This section explains the BTL mode, and describes how to use it.

Theory of Operation

BTL mode (also called 'bridged' mode) uses both channels of the PA-30 to form a single monophonic amplifier with significantly higher power capability. If your loudspeakers can handle the increased power, BTL mode will give you more headroom - resulting in undistorted reproduction of program peaks and significantly greater 'punch' from your system.

When the MODE switch is in the 'BTL (MONO)' position, only the Channel A input is active; the Channel B input is disabled, and signals present at either of the Channel B input connectors are ignored by the amplifier. The signal at the Channel A input is amplified and sent to both outputs of the PA-30, *but the polarity of Channel B is reversed with respect to Channel A*. In other words, the two channels are intentionally out of phase.

The single load (remember, BTL is a monophonic, or single-channel, mode) is wired across the two channel output 'hot' (red) terminals, and the black output terminals are left unconnected. The minimum allowable load impedance is 8 ohms (not 4 ohms, as is the case in stereo mode), and the available power to the load is 50 watts continuous (at 8 ohms).

BTL mode is electrically identical to push-pull transmission at line level (the signal level is simply much higher): the two channel outputs deliver the same absolute signal voltage, but with opposite polarities. So, when the Channel A output is at +10 volts, for example, the Channel B output is at -10 volts. The difference between the two (which is the total voltage across the load) is then 20 volts.

The voltage across the load is thus effectively doubled – which doubles the power.

Notice there is a crucial difference between BTL mode and what is normally termed 'mono' in the HiFi world. When we select 'mono' on a HiFi preamp or integrated amplifier, what we intend - and what we get - is the same signal from both speakers *with the same polarity*. It is very important to understand the distinction between this and BTL mode, because if two speakers are connected to the PA-30 in a normal stereo configuration and the MODE switch is set to 'BTL', the system still works but the two speakers are out of phase. This will cause acoustical cancellations at low frequencies, resulting in poor sound quality. In rare cases, it can even cause a woofer to blow out!

Connections

Before changing the position of the MODE switch or making any input and output connections, turn OFF the PA-30. To select BTL operation, move the MODE switch to the 'BTL (MONO)' position.

Figure 9 illustrates the connections for BTL mode. The input signal is connected to the Channel A input, using either the -10 dBV (RCA) or the +4 dBm (XLR) connector. The Channel B input is left unconnected.

The load is connected across the two output 'hot' (red) terminals, and the black terminals are left unconnected. Be sure to observe correct output polarity: Channel A is positive, and Channel B is negative. Note that the minimum permissible load impedance in BTL mode is 8 ohms.

Connecting loads with a lower impedance will result in current limiting, and may trigger the Protection circuits to shut down the amplifier.

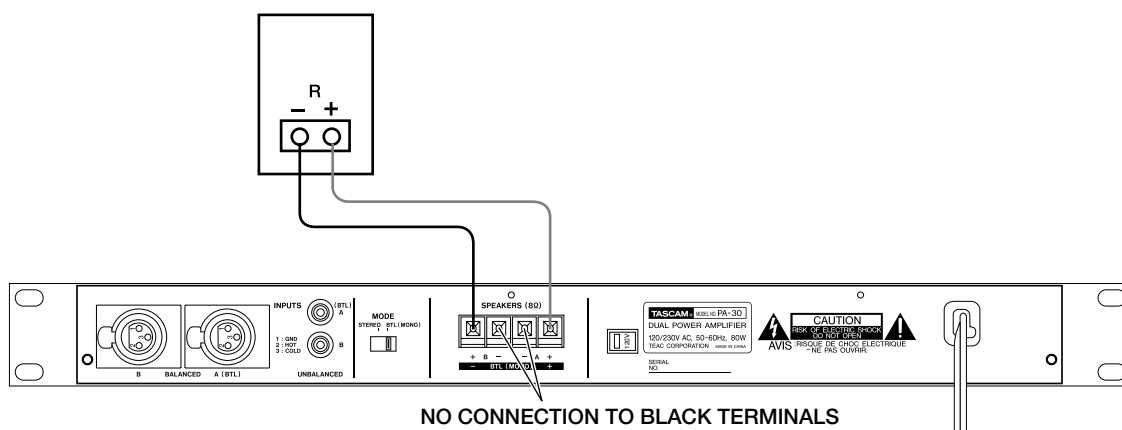

Figure 9. BTL Mode Connection

Specifications

Output power at 8 ohms, (1 kHz):

30 Watts minimum RMS per channel in stereo mode, both channels driven. (0.05% THD)

60 Watts minimum RMS in BTL (monophonic) mode. (0.08% THD)

Total Harmonic Distortion (1 kHz):

0.05% (30 Watts 8 ohms, STEREO)

0.08% (60 Watts 8 ohm, BTL)

Intermodulation Distortion:

Less than 0.2%, 70Hz: 7kHz (4:1)

Frequency Response:

20 Hz to 20 kHz, +0, 1 dB at rated power output.

Damping Factor:

80 minimum, 8 ohm load. 20 Hz to 20 kHz.

Input Impedance and Sensitivity:

-10dBV (0.3 volt RMS) for rated output, 15 kohm unbalanced at RCA input.

+1.3 dBu (0.9 volts RMS) for rated output, 40 kohm balanced at XLR input.

Hum and Noise:

85 dB below rated output.

Minimum Load Impedance:

8 ohms per channel, stereo mode.

8 ohms, BTL mode.

Protection Circuits:

DC balance voltage protector; electronic output power overload protector

Semiconductor Complement:

9 transistors, 8 diodes, 2 integrated circuits, 3 LEDs.

Power Requirements:

120/230 volts, 50/60 Hz, AC switchable;

8 Watts at idle, 130 Watts at rated output.

Weight:

4.5 kg net; 5.5 kg in shipping carton.

Physical Dimensions:

2.1" (54 mm) high, 19" (482 mm) wide, 10.9" (276 mm) deep.

NOTES:

Specifications subject to change without notice.

0 dBV is referenced to 1 volt RMS.

0 dBu is referenced to 0.775 volt RMS.

TASCAM

TEAC Professional Division

PA-30

TEAC CORPORATION

Phone: (0422) 52-5082

3-7-3, Nakacho, Musashino-shi, Tokyo 180-8550, Japan

TEAC AMERICA, INC.

Phone: (323) 726-0303

7733 Telegraph Road, Montebello, California 90640

TEAC CANADA LTD.

Phone: 905-890-8008 Facsimile: 905-890-9888

5939 Wallace Street, Mississauga, Ontario L4Z 1Z8, Canada

TEAC MEXICO, S.A. De C.V

Phone: 5-851-5500

Campeminos 184, Col. Granjes Esmeralda. CP 09810, Mexico DF

TEAC UK LIMITED

Phone: 01923-819699

5 Marlin House, Croxley Business Park, Watford, Hertfordshire. WD1 8TE, U.K.

TEAC DEUTSCHLAND GmbH

Phone: 0611-71580

Bahnstrasse 12, 65205 Wiesbaden-Erbenheim, Germany

TEAC FRANCE S. A.

Phone: 01.42.37.01.02

17 Rue Alexis-de-Tocqueville, CE 005 92182 Antony Cedex, France

TEAC BELGIUM NV/SA

Phone: 0031-162-510210

Oeverkruid 15, NL-4941 VV Raamsdonksveer, Netherlands

TEAC NEDERLAND BV

Phone: 0162-510210

Oeverkruid 15, NL-4941 VV Raamsdonksveer, Netherlands

TEAC AUSTRALIA PTY.,LTD. A.B.N. 80 005 408 462

Phone: (03) 9644-2442

106 Bay Street, Port Melbourne, Victoria 3207, Australia

TEAC ITALIANA S.p.A.

Phone: 02-66010500

Via C. Cantù 11, 20092 Cinisello Balsamo, Milano, Italy

Free Manuals Download Website

<http://myh66.com>

<http://usermanuals.us>

<http://www.somanuals.com>

<http://www.4manuals.cc>

<http://www.manual-lib.com>

<http://www.404manual.com>

<http://www.luxmanual.com>

<http://aubethermostatmanual.com>

Golf course search by state

<http://golfingnear.com>

Email search by domain

<http://emailbydomain.com>

Auto manuals search

<http://auto.somanuals.com>

TV manuals search

<http://tv.somanuals.com>