

## VHLE SERIES

### SUPER STEAMER, ELECTRIC BOILER

### TWO OR THREE COMPARTMENT MODELS



- VHL2E (S) (P)** 2 compartments
- VHL3E (S) (P)** 3 compartments

#### STANDARD FEATURES

- 6 psi pressure steam cooker.
- Cooker body is 8 gauge satin finish type 304 stainless steel exterior. Doors have a removable aluminum alloy inner liner with full perimeter gasket and sealed by turning a "T" type handle. The door cannot be opened when the steamer is on.
- Automatic timed compartment controls with 60 minute timer add the suffix "S" to the model number.
- Lift-out stainless steel wire Adapt-A-Pan™ supports eight 2½", six 4" or four 6" deep food pans (one for 2 compartments) (two for 3 compartments) and one manual pull out shelf.
- Water fall front edge compartment interior bottom to lip out at front.
- Steamer mounted on 28" high base cabinet with stainless steel frame, front full height doors, slip-off stainless steel sides and aluminized rear panel with 6" adjustable legs with flanged feet for anchoring.
- 24 KW electric steam boiler builds 2.3 BHP. Includes CSD-1 compliant high pressure limit switch (15 psi), low water cut-off, automatic water fill, automatic boiler blowdown, 15 psi pressure relief valve and 15 psi kettle connection.
- Service connections include ½" cold water connection for boiler feed and ½" cold water condenser and 1¼" drain connection.
- One year limited parts and labor warranty.



#### SPECIFICATIONS:

Gas fired boiler Super Steamer, Vulcan-Hart Model No. (VHL2E) (VHL3E). 6 psi pressure steam cooker. Cooker body is 8 gauge satin finish type 304 stainless steel exterior. Doors have a removable aluminum alloy inner liner with full perimeter gasket and sealed by turning a "T" type handle. The door cannot be opened while the steamer is on. Automatic timed compartment controls with 60 minute timer, add the suffix "S" to the model number. Lift-out stainless steel wire Adapt-A-Pan™ supports eight 2½", six 4", or four 6" deep food pans (one for 2 compartments)(two for 3 compartments) and one manual pull out shelf. Water fall compartments interior bottom to lip out at front. Steamer mounted on 28" high base cabinet with stainless steel frame, front full height doors, slip-off stainless steel sides and aluminized rear panel with 6" adjustable legs with flanged feet for anchoring. 24 KW steam boiler builds 2.3 BHP. Includes CSD-1 compliant high pressure limit switch (15 psi), low water cut-off, automatic water fill, automatic boiler blowdown, 15 psi pressure relief valve and 15 psi kettle connection. Service connections include: ½" water connection for boiler feed and ½" cold water condenser and 1¼" drain connection.

#### Exterior dimensions:

VHL2E: 36"w x 35⅞"d x 65"h.

VHL3E: 36"w x 35⅞"d x 80"h.

#### **SPECIFY TYPE OF GAS WHEN ORDERING.**

#### **SPECIFY ALTITUDE WHEN ABOVE 2,000 FT.**

UL listed. UL classified to Canadian safety standards. Classified by U L to NSF Std. #4. Meets ASME code.

#### OPTIONS

- PreVent™, automatic load compensated timed, combination pressure and free venting cooking with automatic exhaust, add the suffix "P" to the model number.
- 36 KW, 208 or 240 volt, 60 Hz, 3 phase.
- 42 KW, 208 volt, 60 Hz, 3 phase.
- 48 KW, 240 volt, 60 Hz, 3 phase.
- Correction facility package:
  - a. Cabinet door with hasp (lock by others).
  - b. Security type tamper resistant fasteners.
  - c. Control cover (lock by others).
- Mount and interconnect boiler base with kettle at factory. Includes steam supply piping. Shipped on one skid.
- Second year extended limited parts and labor warranty.

#### ACCESSORIES

- Interconnecting steam supply plumbing kit.
- Manual sliding shelf (Qty. \_\_\_\_).
- Removable 12 x 20 sliding shelf (Qty. \_\_\_\_).
- Adapt-A-Pan™ support (Qty. \_\_\_\_).
- Water treatment system.

### SERVICE CONNECTIONS:



**ELECTRICAL CONNECTION:** Junction box for electrical connection for boiler heat and controls.



**DRAIN:** Condenser box, compartment and boiler, 1 1/2" NPT. (Provide an open air type drain within 12" of condenser box and for best results at a distance so that steam vapors will not enter the steamer from underneath the control area. Do not connect solidly to any drain connections.)



**COLD WATER CONNECTION:** 1/2" NPT for boiler feed. Inlet water pressure between 20 and 80 psi.



**COLD WATER CONNECTION:** 1/2" NPT for condensate box. Inlet water pressure between 20 and 80 psi.

**WATER:** For swing faucet, (single) (dual) temperature 1/4" IPS tailpiece.



**STEAM TAKE-OFF CONNECTION:** 3/4" NPT.

Total Conn. KW	NOMINAL AMPS PER LINE					
	Three Phase				Single Phase	
	208	240	480	380/50/60, 4 wire	208	240
24	66.0	58	29	31	116	100
36	99.9	86.6	43.3	46	N/A	N/A
42	118	N/A	N/A	N/A	N/A	N/A
48	N/A	116	58	62	N/A	N/A

### NOTE:

- Dimensions which locate the above connections have a tolerance of + or -3" (+ or -75 mm).
- Installation of backflow preventers, vacuum breakers and other specific code requirements is the responsibility of the owner and installer. It is the responsibility of the owner and installer to comply with local codes.
- Plastic drains are not recommended due to inherent limited temperatures of the plastic. Boiler purge temperatures may exceed 180°F. The installer may be required to provide means to reduce boiler purge water temperature to be that of the condensate temperature of 140°F or less.
- This appliance is manufactured for commercial installation only and is not intended for home use.

### WATER QUALITY STATEMENT:

The fact that a water supply is potable is no guarantee that it is suitable for steam generation. Your water supply must be within these general guidelines:

<b>SUPPLY PRESSURE</b>	20 - 60 psig
<b>HARDNESS*</b>	less than 3 grains
<b>SILICA</b>	less than 13 ppm
<b>TOTAL CHLORIDE</b>	less than 4.0 ppm
<b>pH RANGE</b>	7-8
<b>UN-DISSOLVED SOLIDS</b>	less than 5 microns
* 17.1 ppm = 1 grain of hardness	

Other factors affecting steam generation are iron content, amount of chloridation and dissolved gases. Water supplies vary from state to state and from locations within a state. Therefore it is necessary that the local water treatment specialist be consulted before the installation of any steam generating equipment.

### PAN CAPACITIES (Per compartment)

MODEL	1" deep	2 1/2" deep	4" deep	18"x26"x1"
VHLE	16	8	6	6

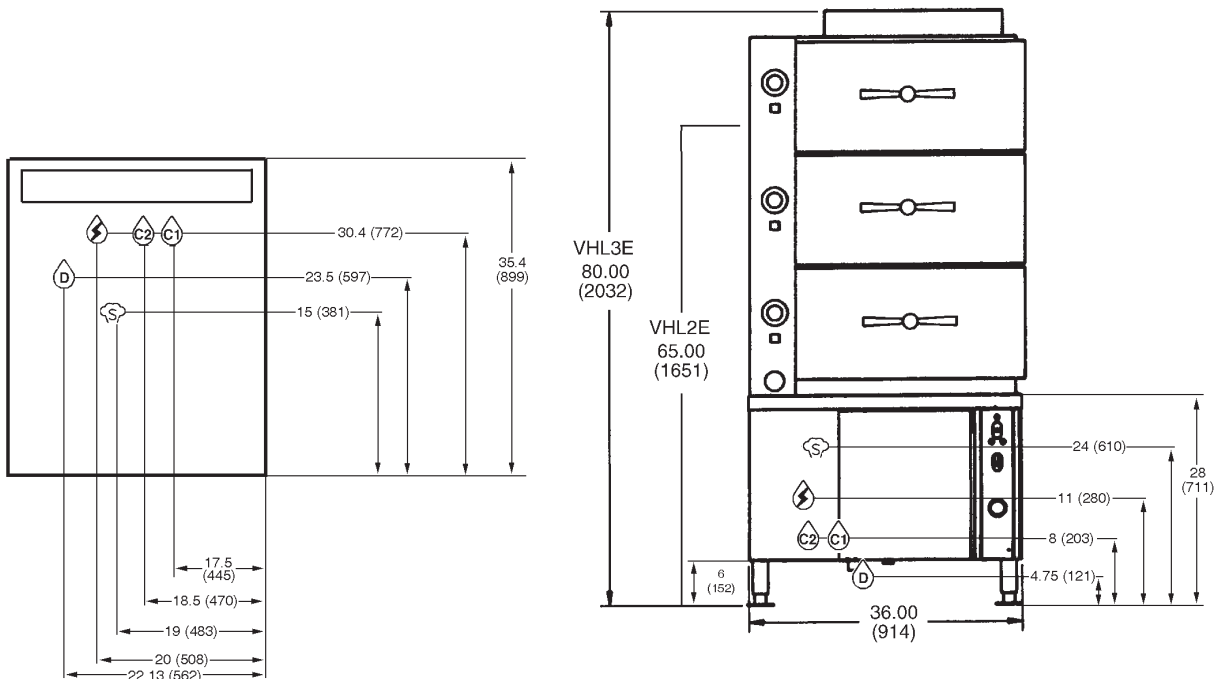

**NOTE:** In line with its policy to continually improve its products, Vulcan-Hart Company reserves the right to change materials and specifications without notice.

## Free Manuals Download Website

<http://myh66.com>

<http://usermanuals.us>

<http://www.somanuals.com>

<http://www.4manuals.cc>

<http://www.manual-lib.com>

<http://www.404manual.com>

<http://www.luxmanual.com>

<http://aubethermostatmanual.com>

Golf course search by state

<http://golfingnear.com>

Email search by domain

<http://emailbydomain.com>

Auto manuals search

<http://auto.somanuals.com>

TV manuals search

<http://tv.somanuals.com>