



INSTRUCTION MANUAL

9 SPEED DRILL PRESS

Item# 7149
Model # ZJ4116QA



PLEASE READ AND SAVE ALL INSTRUCTIONS TO ENSURE THE SAFE AND EFFECTIVE USE OF THIS TOOL.

TABLE OF CONTENTS

Index	P. 1
Important Safety Instructions	P. 2
Safety Instruction for Drill Press	P. 3 - 7
General Safety Rules	P. 8, 9
List of Main Parts	P. 10
Tech. Specifications, Contents of Packaging	P. 11
Assembly and Operation	P. 12 - 16
Maintenance	P. 17
Trouble Shooting	P. 17, 18
Service Center	P. 18
Warranty Information	P. 19
Warranty Card	P. 20



IMPORTANT SAFETY INSTRUCTIONS

PLEASE READ THESE INSTRUCTIONS CAREFULLY TO ENSURE THE SAFE AND EFFECTIVE USE OF THIS TOOL.

WARNING: READ ALL INSTRUCTIONS. Failure to follow the IMPORTANT SAFEGUARDS listed BELOW, and other basic safety precautions, may result in serious personal injury.

1. KEEP TRANSPARENT CHUCK GUARDS IN PLACE and in working order.
2. REMOVE ADJUSTING KEYS AND WRENCHES. Form habit of checking to see that keys and adjusting wrenches are removed from tool before turning it on.
3. KEEP WORK AREA CLEAN. Cluttered areas and benches invite accidents.
4. DON'T USE IN DANGEROUS ENVIRONMENT. Don't use power tools in damp or wet locations, or expose them to rain. Keep work area well lit.
5. KEEP CHILDREN AWAY. All visitors should be kept at a safe distance from work area.
6. MAKE WORKSHOP CHILDPROOF with padlocks, master switches, or by removing starter keys.
7. DON'T FORCE TOOL. Drill Press will do the job better, and safer at the rate for which it was designed.
8. USE RIGHT TOOL. Don't force tool or attachment to do a job for which it was not designed.
9. USE PROPER EXTENSION CORD. Make sure your extension cord is in good condition. When using an extension cord, be sure to use one heavy enough to carry the current your product will draw. An undersized cord will cause a drop in line voltage resulting in loss of power and overheating.
10. WEAR PROPER APPAREL. Do not wear loose clothing, gloves, neckties, rings, bracelets, or other jewelry which may get caught in moving parts. Non-slip footwear is recommended. Wear protective hair covering to contain long hair.
11. ALWAYS USE SAFETY GLASSES. Also use face or dust mask if cutting operation is dusty. Everyday eyeglasses only have impact resistant lenses, they are NOT safety glasses.
12. SECURE WORK. Use clamps or a vise to hold work when practical. It's safer than using your hand and it frees both hands to operate tool.
13. DON'T OVERREACH. Keep proper footing and balance at all time.
14. MAINTAIN TOOLS WITH CARE. Keep tools sharp and clean for best and safest performance. Follow instructions for lubricating and changing accessories.
15. DISCONNECT TOOLS before servicing and when changing accessories, such as blades, bits, cutters, and the like.
16. REDUCE THE RISK OF UNINTENTIONAL STARTING. Make sure switch is in off position before plugging in.
17. NEVER STAND OR LEAN ON TOOL. Serious injury could occur if the tool is tipped or if the cutting tool is unintentionally contacted.

SAVE THESE INSTRUCTIONS!

18. CHECK DAMAGED PARTS. Before further use of the tool, a guard or other part that is damaged should be carefully checked to determine that it will operate properly and

perform its intended function. Check for alignment of moving parts, binding of moving parts, breakage of parts, mounting, and any other conditions that may affect its operation. A guard or other part that is damaged should be properly repaired or replaced.

19. DIRECTION OF FEED. Feed work into a blade or cutter against the direction of rotation of the blade or cutter only.
20. NEVER LEAVE TOOL RUNNING UNATTENDED. TURN POWER OFF and unplug from power supply. Don't leave tool until it comes to a complete stop.

SAFETY INSTRUCTIONS FOR DRILL PRESS

Safety is a combination of common sense, staying alert and knowing how your drill press works. Read and save this manual to understand this drill press.

When Installing or Moving the Drill Press

Reduce the Risk of Dangerous Environment

- Use the drill press in a dry, indoor place protected from rain.
- Keep work area well lit.

Reduce the Risk of Injury from Unexpected Drill Press Movement

If there is any tendency of the drill press to tilt or move during any use, bolt it to the floor. Make sure to leave adequate room to fully open the belt guard. If the workpiece is too large to easily support with one hand, provide an auxiliary support.

- To reduce the risk of injury from electrical shock, make sure your fingers do not touch the plug's metal prongs when plugging in or unplugging the drill press.
- **Never Stand or Lean on Tool.** Serious injury could occur if the tool tips or you accidentally hit the cutting tool. Do not store anything above or near the tool where anyone might stand on the tool to reach for tools above them.

Before Each Use

Inspect Your Drill Press

- To reduce the risk of injury from accidental starting, turn the switch off, unplug the drill press, and remove the switch key before raising the guard, changing the cutting tool, changing the setup, or adjusting anything. Make sure switch is in OFF position before plugging in.
- Check for alignment of moving parts, binding of moving parts, breakage of parts, drill press stability, and any other conditions that may affect the way the drill press works.
- If any part is missing, bent or broken in any way, or any electrical part does not work properly, turn the drill press off and unplug the drill press.
- Replace damaged or missing parts before using the drill press again.
- Remove adjusting keys and wrenches. Form a habit of checking for and removing keys and adjusting wrenches from table top before turning drill press on.
- Make sure all clamps and locks are tight and no parts have excessive play.

Use Only Accessories Designed For This Drill Press To Reduce The Risk of Serious Injury From Thrown Broken Parts Or Workpieces

- When cutting large diameter holes:
 - Clamp the workpiece firmly to the table. Otherwise the cutting may grab and spin it at high speed.

- Use only one piece, cup-type, hole cutters.
- **Do not** use fly cutters or multi-part hole cutters as they can come apart or become unbalance in use.
- Keep speed below 1500rpm.
- Drum sanders must **never** be operated on this drill press at a speed greater than 1800rpm.
- Do not install or use any drill that exceed 7" in length or extends 6" below the chuck jaws. They can suddenly bend outward or break.
- Do not use wire wheels, router bits, shaper cutters, circle (fly) cutters or rotary planers on this drill press.

Kickback

- Kickback is the grabbing of the workpiece by the rotating tool. The workpiece can be thrown at a very high speed in the direction of rotation. **This Can Cause Serious Injury.** To reduce the possibility of injury from kickback:
 - Clamp the workpiece firmly to the table whenever possible.
 - Buffing or sanding wheels or drums should be contacted on the side moving away from you, not the side moving toward you.
 - Use only recommended accessories and follow the instructions supplied with the accessory.

This drill press has 9 speeds as listed below:

335 RPM	568 RPM	715 RPM
752 RPM	944 RPM	1200 RPM
1890 RPM	2280 RPM	2815 RPM

See inside of guard for specific placement of belt on pulleys.

Think Safety

Safety is a combination of operator common sense and alertness at all times when the drill press is being used.

WARNING: Do not allow familiarity (gained from frequent use of your drill press) to become commonplace. Always remember that a careless fraction of a second is sufficient to inflict severe injury.

Plan Your Work

- Don't force the tool. Drill Press will do the job better and safer at the rate for which it was designed.
 - Use the right tool. Don't force tool or attachment to do a job it was not designed to do.
 - If any part of your drill press is missing, malfunctioning, has been damaged or broken, such as the motor switch, or other operating control, a safety device or the power cord, turn the drill press off and unplug it until the particular part is properly repaired or replaced.
 - Never place your fingers in a position where they could contact the drill or other cutting tool if the workpiece should unexpectedly shift or your hand should slip.
 - To reduce the risk of injury from parts thrown by the spring, follow instructions exactly as given and shown in adjusting spring tension of quill.
-
- To prevent the workpiece from being torn from your hands, spinning of the tool, shattering the tool or being thrown, always properly support your work so it won't shift or bind on the tool:
 - Always position backup material (use beneath the workpiece) to contact the left

- side of the column.
- Whenever possible, position the workpiece to contact the left side of the column
 - If it is too short to the table, use table slots or clamping ledge around the outside edge of the table.
 - When using a drill press vise, always fasten it to a table.
 - Never do any work “Freehand” (hand holding workpiece rather than supporting it on the table), except when polishing.
 - Securely lock head to column, table support to column and table to table support before operating drill press.
 - Never move the head or table while the tool is running.
 - Before starting the operation, jog the motor switch to make sure the drill or other cutting tool does not wobble or cause vibration.
 - If a workpiece overhangs the table such that it will fall or tip if not held, clamp it to the table or provide auxiliary support.
 - Use fixtures for unusual operations to adequately hold, guide and position workpiece.
 - Use the spindle speed recommended for the specific operation and workpiece material.
- Never climb on the drill press table, it could break or pull the entire drill press down on you.
 - Turn the motor switch off, unplug from power supply, and put away the switch key when leaving the drill press.
 - To reduce the risk of injury from thrown work or tool contact, do not perform layout, assembly or setup work on the table while the cutting tool is rotating.
 - Don't overreach. Keep proper footing and balance at all times.
 - Maintain tools with care. Keep tools sharp and clean for best and safest performance. Follow instructions for lubricating and changing accessories.

Plan Ahead to Protect Your Eyes, Hands, Face and Ears Dress for Safety

- Do not wear loose clothing, gloves, neckties or jewelry (rings, wrist watches). They can get caught and draw you into moving parts.
- Wear non-slip footwear.
- Tie back long hair.
- Roll long sleeves above the elbow.
- Noise levels vary widely. To reduce the risk of possible hearing damage, wear ear plugs or muffs when using drill press for hours at a time.
- Always wear safety glasses. Any power tool can throw foreign objects into the eyes. This can result in permanent eye damage. Everyday eyeglasses have only impact resistant lenses. They are not safety glasses.
- For dusty operations, wear a dust mask along with safety goggles.

Reduce the Risk of Accidental Starting

- Make sure switch is “OFF” before plugging drill press into a power outlet.

Keep Children Away

- Keep all visitors at safe distance from the drill press.
- Make sure bystanders are clear of the drill press and workpiece.

Before Leaving the Drill Press

- Turn the drill press off.

- Wait for tool bit to stop spinning.
- Unplug the drill press.
- Make workshop child-proof. Lock the shop. Disconnect master switches. Remove the yellow switch key. Store it away from children and others not qualified to use the tool.

Electrical Requirements

General Electrical Connections

DANGER: To reduce the risk of electrocution:

1. Use only identical replacement parts when servicing. Servicing should be performed by a qualified service technician.
2. Do not use in rain or where floor is wet.

This tool is intended for indoor residential use only.

WARNING: Do not permit fingers to touch the terminals of plug when installing or removing the plug to or from the outlet.

Grounding Instructions

110-120 Volt, 60Hz. Tool Information

NOTE: The plug supplied on your tool may not fit into the outlet you are planning to use. Your local electrical code may require slightly different power cord plug connections. If these differences exist refer to and make the proper adjustments per your local code before your tool is plugged in and turned on.

In the event of a malfunction or breakdown, grounding provides a path of least resistance for electric current to reduce the risk of electric shock. This tool is equipped with an electric cord having an equipment grounding conductor and a grounding plug, as shown. The plug must be plugged into a matching outlet that is properly installed and grounded in accordance with all local codes and ordinances.

Do not modify the plug provided. If it will not fit the outlet, have the proper outlet installed by a qualified electrician.

A temporary adapter may not be used with this item.

WARNING: If not properly grounded, this tool can cause an electrical shock, particularly when used in damp locations, in proximity to plumbing, or out of doors. If an electrical shock occurs there is the potential of a secondary hazard, such as your hands hitting the cutting tool.

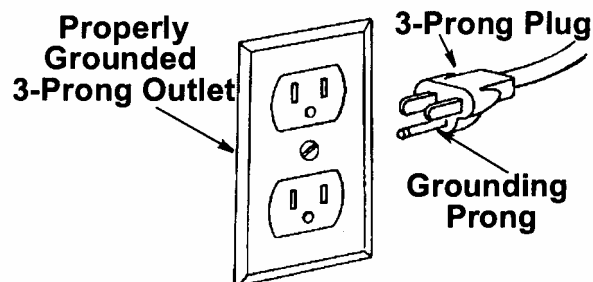

Wire Sizes

NOTE: Make sure the proper extension cord is used and is in good condition. The use of any extension cord will cause some loss of power. To keep this to a minimum and to prevent overheating and motor burnout, use the table as below to determine the minimum wire size (A.W.G.) extension cord.

Use only 3-wire extension cords which have 3-prong grounding type plugs and 3-pole receptacles which accept the tools plug.

Extension Cord Length	Gauge (A.W.G.)
0-25	12
25-50	10

SAVE THESE INSTRUCTIONS!

GENERAL SAFETY RULES

WARNING! Read, understand and save all instructions. Failure to follow all instructions listed below may result in electric shock, fire or serious personal injury. The warnings, cautions, and instructions discussed in this instruction manual cannot cover all possible conditions and situations that may occur. It must be understood by the operator that common sense and caution are a factor which cannot be built into this product, but must be supplied by the operator.

SAVE ALL INSTRUCTIONS!

WORK AREA

1. Keep your work area clean and well organized. Cluttered benches and dark areas invite accidents.
2. Do not operate power tools in explosive atmospheres, such as in the presence of flammable liquids, gases, or dust. Power tools create sparks which may ignite the dust or fumes.
3. Keep bystanders, children and visitors away while operating a power tool. Distractions can cause you to lose control.

ELECTRICAL SAFETY

Do not abuse the cord. Never use the cord to carry the tool. Keep cord away from heat, oil, sharp edges or moving parts. Replace damaged cords immediately. Damaged cords may create a risk of fire.

PERSONAL SAFETY

1. Stay alert, watch what you are doing and use common sense when operating a power tool. Do not use tool while tired or under the influence of drugs, alcohol or medication. A moment of inattention while operating power tools may result in serious personal injury.
2. Dress properly. Do not wear loose clothing or jewelry. Contain long hair. Keep your hair, clothing and gloves away from moving parts. Wear protective goggles when operating the machine. It is recommended to wear protective goggles, gloves, sturdy non-slipping shoes and an apron.
3. Avoid accidental starting. Be sure switch is in OFF position before connecting to a power outlet. Carrying tools with your finger on the switch when the switch is ON invites accidents. Disconnect tool from power outlet before carrying out any work on the machine.
4. Remove adjusting wrench before turning the tool on. A wrench or a key that is left attached to a rotating part of the tool may result in personal injury
5. Do not overreach. Keep proper footing and balance at all times. Proper footing and balance enables better control of the tool in unexpected situations.
6. Use safety equipment. Always wear eye protection. Dust mask, non-skid safety shoes, hard hat, or hearing protection must be used for appropriate conditions.



TOOL USE AND CARE

1. Use clamps or other practical way to secure and support the work piece to a stable platform. Holding the work by hand or against your body is unstable and may lead to loss of control.
2. Do not force tool. Use the correct tool for your application. The correct tool will do the job better and safer at the rate for which it is designed.
3. Do not use tool if switch does not turn ON or OFF. Any tool that cannot be controlled

- with a switch is dangerous and must be repaired.
4. Place the switch in locked or OFF position before making any adjustments, changing accessories or storing the tool. Such preventive safety measures reduce the risk of starting the tool accidentally.
 5. Store idle tools out of reach of children and other untrained persons. Tools are dangerous in the hands of untrained users. They should be kept away from work area.
 6. Maintain tools with care. Keep cutting tools sharp and clean. Properly maintained tools, with sharp cutting edges are less likely to bind and are easier to control.
 7. Check for misalignment or binding of moving parts, breakage of parts and any other condition that may affect the tools operation. If damaged, have the tool serviced before using. Many accidents are caused by poorly maintained tools.
 8. Use only accessories that are recommended by the manufacturer for your model. Accessories that may be suitable for one tool may become hazardous when used on another tool.

SERVICE

1. Tool service must be performed only by qualified repair personnel. Service or maintenance performed by unqualified personnel could result in a risk of injury.
2. When servicing a tool, use only identical replacement parts. Follow instructions in the maintenance section of this manual. Use of unauthorized parts or failure to follow Maintenance Instructions may create a risk of electric shock or injury.

SAVE THESE INSTRUCTIONS!

LIST OF MAIN PARTS

Before attempting to use, familiarize yourself with all the operating features and safety requirements of your drill press.

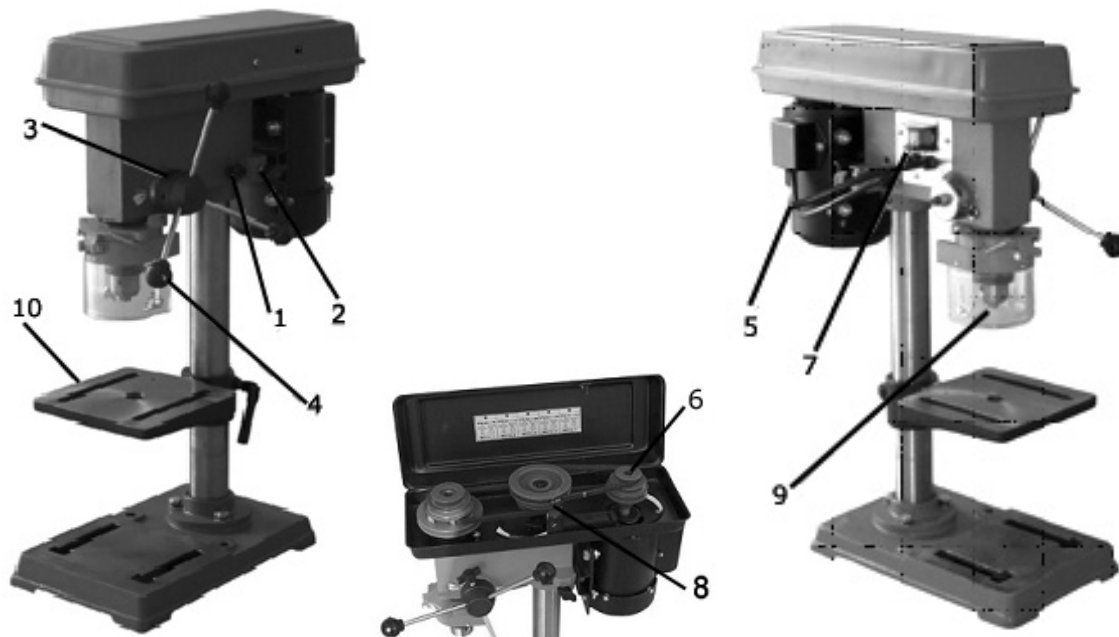

- 1. Belt tension lever** - The belt tension lever is used to release or tighten belt tension.
- 2. Belt tension knob** - Belt tension knobs on both sides of the pulley housing lock the belt tension lever in place.
- 3. Depth gauge** - A depth gauge is located between the pulley housing and operating handles to aid drilling at desired depth.
- 4. Operating handles** - Operating handles raise and lower the chuck and bit during the drilling operation.
- 5. Motor** - Equipped with an industrial duty, induction motor for long lasting, smooth performance.
- 6. Pulley and belts** - Nine spindle speeds can be obtained by adjusting the position of the belts on the pulleys to allow drilling of a variety of materials (i.e. wood, plastic or metal).
- 7. Safety switch and switch key** – Your drill press has an easy access power switch. To lock in the OFF position, remove the switch key. Place the key in a location inaccessible to children and others not qualified to use the tool.
- 8. Pulley** - The drill press has three pulleys to obtain 9 different speeds.
- 9. Chuck guard** - A transparent chuck guard will help protect hands from the rotating drill bit during the drilling operation.
- 10. Worktable** - For added versatility, the worktable can be tilted. The slotted worktable and base allows easy application of clamping devices.

TECHNICAL SPECIFICATIONS:

Model Number	ZJ4116QA
Rating Voltage	120 Volts, 60Hz, AC
Chuck Size	5/8"
Net Weight	46.2 Lbs
Number Speeds	9
Spindle Stroke	2"
Spindle Taper	MT2

CONTENTS OF PACKAGING

Check all loose parts from the box with the list below. Assemble according to the instruction on the following pages.

1. Drill press head and motor
2. Column and base flange
3. Base
4. Table
5. Chuck guard
6. Bolts for base and column
7. Chuck
8. Chuck key
9. Operating handles
10. 3mm and 4mm wrench

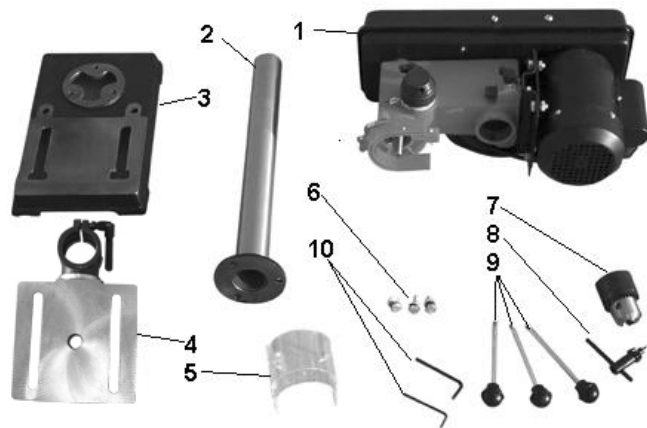

If any of the above items are missing, please contact our service department at 1-888-367-7373 (<http://wwwk.wk-usa.com>) for replacement.

WARNING! To prevent accidental starting that could cause possible serious personal injury, assemble all parts to your drill press before connecting it to power supply. Drill press should never be connected to power supply when you are assembling parts, making adjustments, installing or removing drill bit, or when not in use.

- Carefully remove all parts from the carton and place the drill press on a level work surface. Separate and check against the list of loose parts.

WARNING! If any parts are missing, do not operate this tool until the missing parts are replaced. Failure to do so could result in serious personal injury.

- Do not discard the packing materials until the drill press has been carefully inspected, all parts identified, and drill press has been satisfactorily operated.

Note: If any parts are damaged or missing, do not attempt to plug in the power cord and turn the switch on until the damaged or missing parts are obtained and are installed correctly.

ASSEMBLY AND OPERATION

Warning! For your own safety, do not connect the drill press to the power source until the machine is completely assembled and the entire instruction manual has been read and understood.

Assembly

1. Assemble the column (A) Fig. 4, to drill press base (B) as shown, using the three hex head cap screws (C).

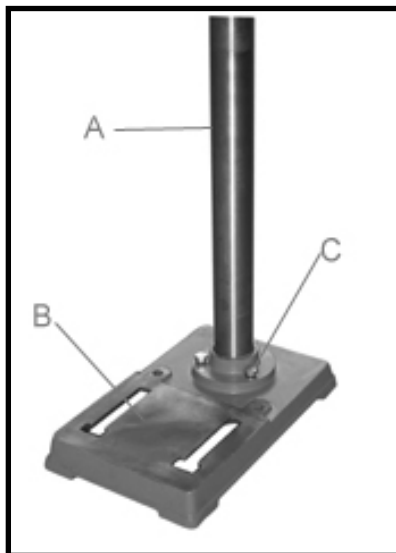

Fig. 4

2. Place the table (D) Fig. 5, on the drill press column (A) as shown.

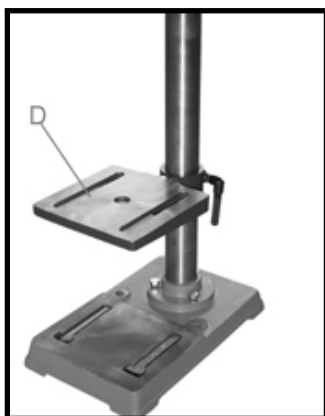

Fig. 5

3. Thread stud on clamp handle (E) Fig. 6, into hole in rear of table bracket as shown.

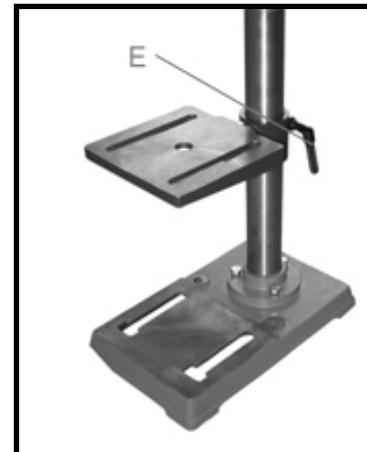

Fig. 6

4. Place the drill press head (F), onto the column (A) as far as it will go. Align head (A) Fig 7A, to table (B), and base (C). Tighten the two head locking screws (G) Fig. 7 with wrench supplied.

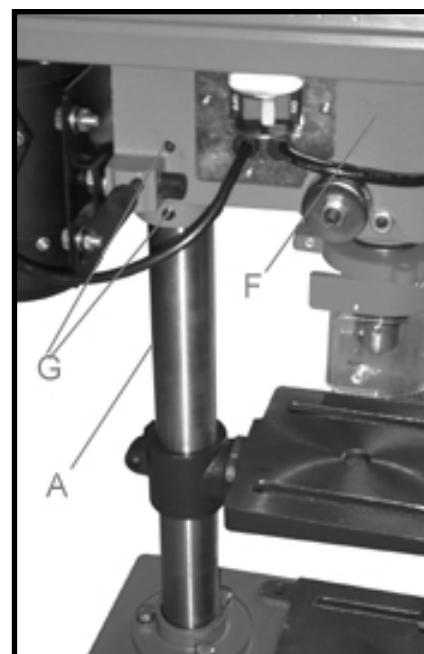

Fig. 7

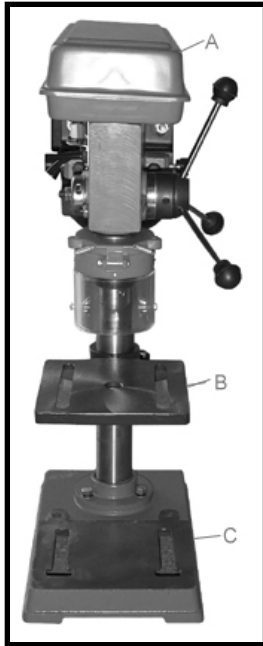

Fig. 7A

5. Thread the three pinion shaft handles (H) Fig. 8, into the three holes located in the handles holder (J) as shown.

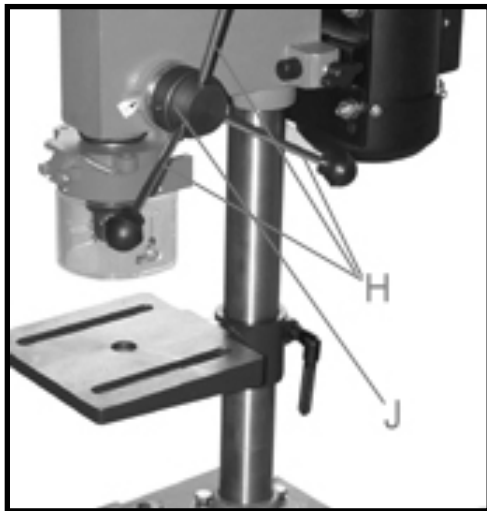

Fig. 8

6. **IMPORTANT:** Make certain the spindle taper (K) Fig. 9, and tapered hole in the chuck (L) are clean and free of any grease, lacquer or rust preventive coatings. Carefully follow the manufacturer's safety rules concerning its use.

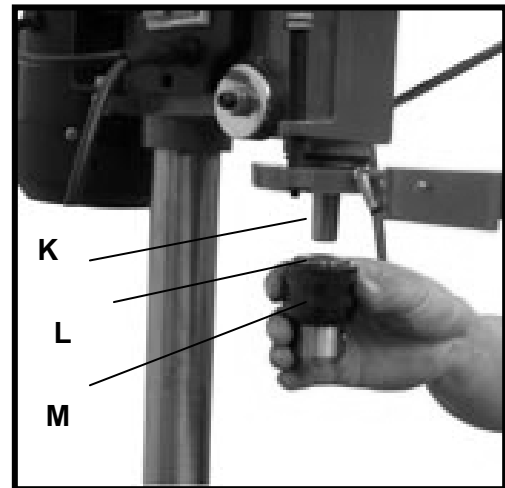

Fig. 9

7. **IMPORTANT:** Open the chuck jaws as wide as possible by turning the chuck sleeve (M) Fig. 10.
8. Holding chuck on taper of spindle, tap with a soft tip hammer (N) or a block of wood and hammer to set chuck, as shown in Fig. 10. **IMPORTANT:** To avoid damage to the chuck, NEVER drive the chuck onto the spindle with a metal hammer.

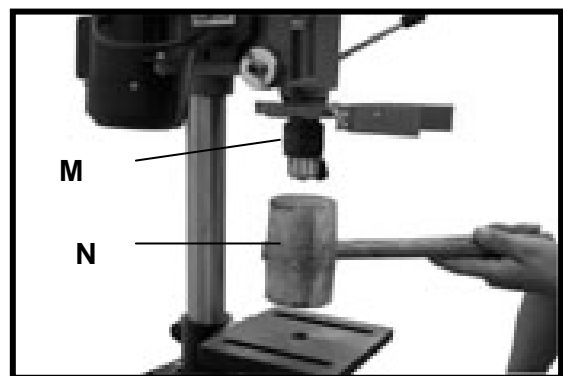

Fig. 10

Fastening drill press to supporting surface

If during operation there is any tendency for the machine to tip over, slide or walk on the supporting surface, the machine base must be secured to the supporting surface with bolts, through the two holes (A) Fig. 11, located in the machine base.

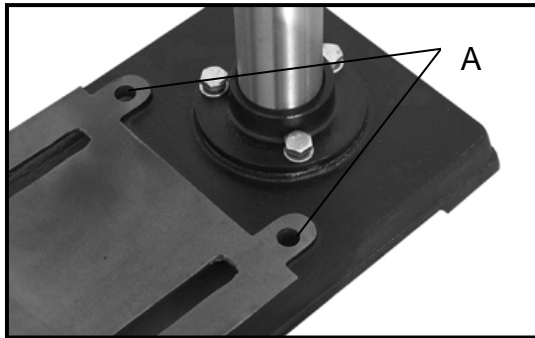

Fig. 11

Table adjustments

1. The table can be raised or lowered on the drill press column by loosening the table clamp handle (A) Fig. 12. Move the table to the desired position on the column and tighten table clamp handle (A).

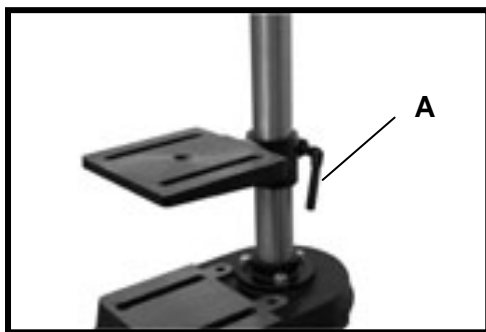

Fig. 12

2. The table can be tilted right or left.



Fig. 13

Changing speeds and adjusting belt tension

Note: A belt positioning speed chart (E) Fig. 14, is located on the inside top cover of the drill press.

1. Disconnect machine from power source.
2. Lift up the belt and pulley cover (A) Fig. 14.
3. Release belt tension by loosening tension knob (B) Fig. 14, and pushing the motor (D) toward the front of the drill press.
4. While holding the motor toward the front of the drill press, position the belt (C) on the desired steps of the motor and spindle pulleys, as shown in Fig. 14.



Fig. 14

5. After the belt is positioned on the desired steps the motor and spindle pulleys, push motor (D) Fig. 14, away from the drill press head until the belt is properly tensioned and tighten tension knob (B). The belt should be just tight enough to prevent slipping. Excessive tension will reduce the life of the belt, pulleys and bearings. Correct tension is obtained when the belt (C) can be flexed about 1 inch out of line midway between the pulleys using light finger pressure.

Operation

Your drill press is to be used with drill bits with a shank 1/2 inch or less in diameter. The following will give the inexperienced operator a start on common drill press operations. Use scrap material for practice to get a feel of the machine before attempting regular work.

Installing and removing drill press

1. Disconnect machine from power source.
2. Insert smooth end of drill bit (A) Fig. 15, into chuck (B), as far as it will go, and then back the bit out 1.5mm, or up to the flutes for small bits.
3. Make certain that the drill bit (A) Fig. 15, is centered in the chuck (B) before tightening the chuck with the key (C).
4. Turn the chuck key (C) Fig. 15, clockwise to tighten and counterclockwise to loosen the chuck jaws.

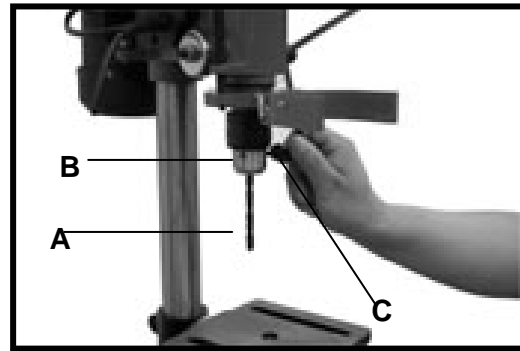

Fig. 15

5. Tighten all three chuck jaws to secure the drill bit sufficiently so that it does not slip while drilling.
6. Make sure chuck key (C) Fig. 15, is removed from chuck before starting drill press.

Correct drilling speeds

Factors which determine the best speed to use are: kind of material being worked, size of hole, type of drilling cutter, and quality of cut desired.

Warning: Use the recommended speed for the drill press bit and workpiece material.

Using vise for clamping the workpiece

1. Take out the 2-1/2" vise from the packaging, and put it on the work table.
2. Use four bolts to fasten the vice on the work table, and adjust the position of vice on the work table at the desired position when operating.

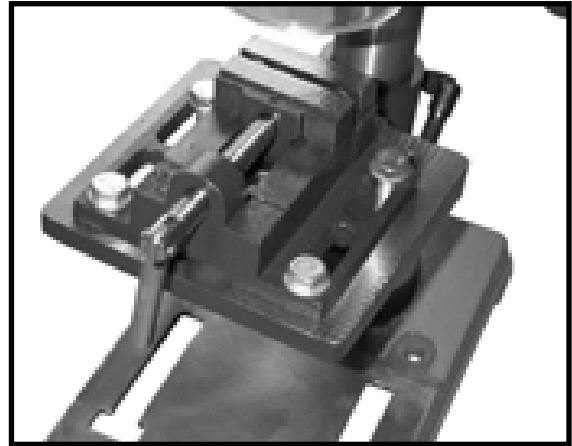

FIG.16

Adjusting Feeding Depth

1. Mark the depth of the hole on the side of the workpiece.
2. Loosen the depth scale lock screw.
3. With the switch to the off position, bring the drill bit down until the tip of the bit is even with the mark on the side of the workpiece. (Fig 17)
4. Turn the depth scale counter-clockwise until it stops moving,
5. Tighten the depth scale lock screw.
6. The drill bit will now stop at the desired depth until the depth scale is readjusted.

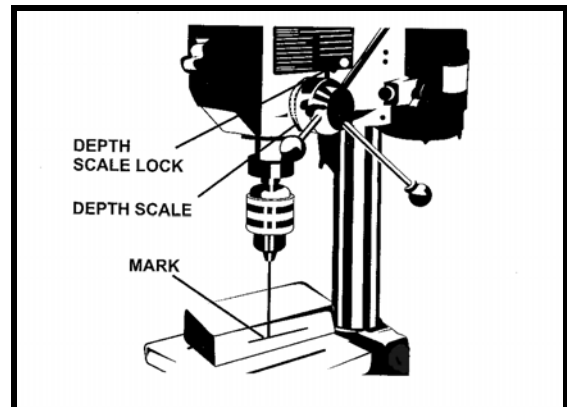

FIG.17

MAINTENANCE

WARNING:

When servicing use only identical replacement parts. Use of any other parts may create a hazard or cause product damage.

WARNING

To avoid serious personal injury make sure the drill press is turned OFF and the cord is unplugged from the power source before performing any maintenance or adjustment.

GENERAL MAINTENANCE

After using your drill press, clean it completely and lubricate all sliding and moving parts. Apply a light coat of automotive type paste wax to the table and column to help keep the surfaces clean.

LUBRICATION

The ball bearings in the quill and V-belt pulley are permanently lubricated. To lubricate the spindle, pull quill down to maximum depth and oil moderately once every three months. Oil all slide bars lightly every two months. If cranking becomes difficult, grease bracket lightly.

TROUBLE SHOOTING

TROUBLE	PROBABLE CAUSE	REMEDY
Noisy operation	A) Incorrect belt tension B) Dry spindle C) Loose pulley D) Loose belt E) Bad bearing	A) Adjust tension B) Remove spindle/quill assembly and lubricate C) Tighten pulley D) Adjust belt tension E) Replace bearing
Excessive drill wobble	A) Loose chuck B) Worn spindle shaft or bearing C) Bad chuck	A) Tighten by pressing chuck down against table B) Replace spindle shaft or bearing C) Replace chuck
Motor won't start	A) Power supply B) Motor connection C) Switch connections D) Motor windings burned E) Bad switch	A) Check power cord B) Check motor connection C) Check switch connections D) Replace motor E) Replace speed
Drill binds in workpiece	A) Excessive pressure on feed handle B) Loose belt C) Loose drill D) Speed too fast	A) Apply less pressure B) Check belt tension C) Tighten drill with key D) Change speed
Drill burns or smokes	A) Incorrect speed slow down RPM B) Chips are not discharging C) Dull drill or not cut properly for material D) Needs lubrication E) Feed pressure wrong	A) Refer to speed chart B) Clean drill C) Clean sharpness and taper D) Use lubrication while drilling E) Apply less pressure
Table difficult to raise	A) Needs lubrication B) Bent rack C) Table lock tightened	A) Lubricate with light oil B) Straighten rack C) Loosen clamp

SERVICE CENTER

If you have any question in regards to the operation of this power tool or are in need of a spare part please contact our service center at:

Wachsmuth & Krogmann, Inc.

Tel: 1-888-367-7373

(Business hours Mon-Fri 9:00am - 4:00pm CT)

Website: <http://www.wk-usa.com>



ENVIRONMENTAL PROTECTION

If the tool should no longer work at all, please make sure that it is disposed in an environmentally friendly way, by handing it into a public collection point. Please do not put it with your household waste.

LIMITED WARRANTY

Thank you for purchasing a top quality **KingCraft** product. This **9 Speed Benchtop Drill Press tem #7149** was tested and meets our stringent quality standards. This product is warranted to be free from manufacturing defects in original materials, including original parts, and workmanship until **June 20, 2006** or 1 year with proof of purchase.

The warranty is void if the defect is due to accidental damage, misuse, abuse, neglect, improper repair or alteration by unauthorized persons or failure to follow operation instructions provided with the product. This warranty does not apply to commercial use.

The warranty is non-transferable and applies only to the original purchase and does not extend to subsequent owners of the product. Liability under this warranty is limited to repair, replacement or refund. In no event shall liability exceed the purchase price paid by the purchaser of the product. Under no circumstances shall there be liability for any loss, direct, indirect, incidental, special or consequential damage arising out of in connection with use of this product. This warranty is valid only in the United States of America. This Warranty gives you specific legal rights. However you may have other rights that vary from state to state. Some states do not allow limitation on implied warranties or exclusion of consequential damages therefore these restrictions may not apply to you.

In case you find the product to be defective please send it within the warranty period to our service center. To avoid transport damages please send the product in the original packaging. In return you will either receive your repaired item, a new product or a refund. Please fill out the Warranty Card and send it together with the product and purchase receipt

To arrange pick-up of the defective item please call our service center:

Wachsmuth & Krogmann Inc.

Tel: 1-888-367-7373 (Business hours Mon-Fri 9:00am-4:00 pm CT)

Website: <http://www.wk-usa.com>

**123 Sivert Court,
Bensenville, IL 60106,
USA**

WARRANTY INFORMATION

WARRANTY CARD

KingCraft

9 Speed Benchtop Drill Press, item # 7149, model # ZJ4116QA

In case you find this product to be defective please send it within the warranty period to our service center. To avoid transport damages please send the product in the original packaging. In return you will receive your repaired item, a new product or a refund.

This product is warranted to be free from manufacturing defects in original materials, including original parts, and workmanship until **June 20, 2006** or 1 year with proof of purchase.

Please fill in your details below and send it together with the product and purchase receipt. Please read the Limited Warranty conditions mentioned in this instruction manual.

Customer Name	
Street	
City	
State	
ZIP Code	
Purchase Date	
Description of Defect :	

To arrange pick-up of the defective item please call our service center:

Wachsmuth & Krogmann Inc.
Tel: 1-888-367-7373 (Business hours Mon-Fri 9:00am-4:00 pm CT)
Website: <http://www.wk-usa.com>
123 Sivert Court,
Bensenville, IL 60106,
USA

PLEASE DETACH THIS SECTION AND RETURN IT WITH YOUR PRODUCT

WARRANTY CARD



Free Manuals Download Website

<http://myh66.com>

<http://usermanuals.us>

<http://www.somanuals.com>

<http://www.4manuals.cc>

<http://www.manual-lib.com>

<http://www.404manual.com>

<http://www.luxmanual.com>

<http://aubethermostatmanual.com>

Golf course search by state

<http://golfingnear.com>

Email search by domain

<http://emailbydomain.com>

Auto manuals search

<http://auto.somanuals.com>

TV manuals search

<http://tv.somanuals.com>