



# SUMMIT<sup>®</sup> 670<sup>™</sup>

56203 US 02/01/10

US ENGLISH

## PARTS LIST • LISTE DES PIÈCES • LISTA DE PIEZAS

**Catch Pan Holder**  
Sostenedor del plato recolector  
Support de l'égouttoir

1

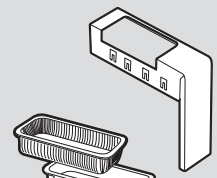

**Catch Pan**  
Plato recolector  
Egouttoir

1



**Cooking Grate**  
Parrilla de cocción  
Grille de cuisson

3

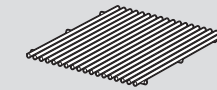

**Warming Rack**  
Rejilla para calentar  
Grille de maintien au chaud

1

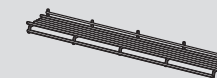

**Battery Housing**  
Compartimiento de las baterías  
Logement des piles

1

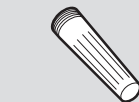

**Rotisserie Fork**  
Horquilla del asador giratorio  
Fourche de la rôtissoire

4



**Rotisserie Spit**  
Espetón del asador giratorio  
Brûche de la rôtissoire

1



**Rotisserie Motor**  
Motor del asador giratorio  
Moteur de la rôtissoire

1

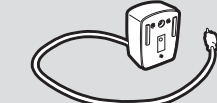

**Drip Tray**  
Bandeja de goteo  
Plateau de recueil des gouttes

1

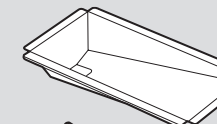

**Flavorizer<sup>®</sup> Bar**  
Barras Flavorizer<sup>®</sup>  
Barre Flavorizer<sup>®</sup>

12



**Smoker Bar**  
Barra del ahumador  
Barre du fumoir

1

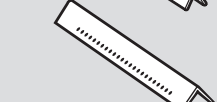

**Smoker Box**  
Caja del ahumador  
Boîtier du fumoir

1

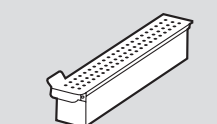

**Side Burner Table**  
Mesa del quemador lateral  
Tablette du brûleur latéral

1

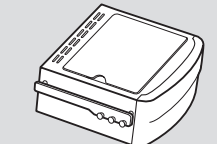

**Side Table**  
Mesa lateral  
Tablette latérale

1

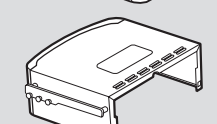

**Hardware:**  
Herrajes:  
Matériel:

**a**

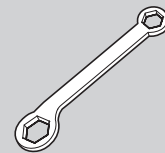

**Wrench - 1**  
Llave - 1  
Clé - 1

**b**



**Nylon Washer - 4**  
Arandela de nilón - 4  
Rondelle de nylon - 4

**c**



**Truss Head Screw**  
( $\frac{1}{4}$  - 20 x  $\frac{5}{8}$  inch) - 4  
Tornillo de cabeza segmentada (Tornillo  $\frac{1}{4}$  - 20 x  $\frac{5}{8}$  pulgadas) - 4  
Vis à tête bombée large de ( $\frac{1}{4}$  - 20 x  $\frac{5}{8}$  pouces) - 4

**d**



**Screw - 3**  
Tornillo - 3  
Vis - 3

**e**

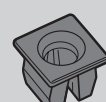

**Plastic Plug - 3**  
Tapón plástico - 3  
Bouchon en plastique - 3

## ASSEMBLY INSTRUCTIONS • INSTRUCCIONES DE MONTAJE • INSTRUCTIONS DE MONTAGE



**TOOLS NEEDED:**  
**HERRAMIENTAS REQUERIDAS:**  
**OUTILS NECESSAIRES:**

3-

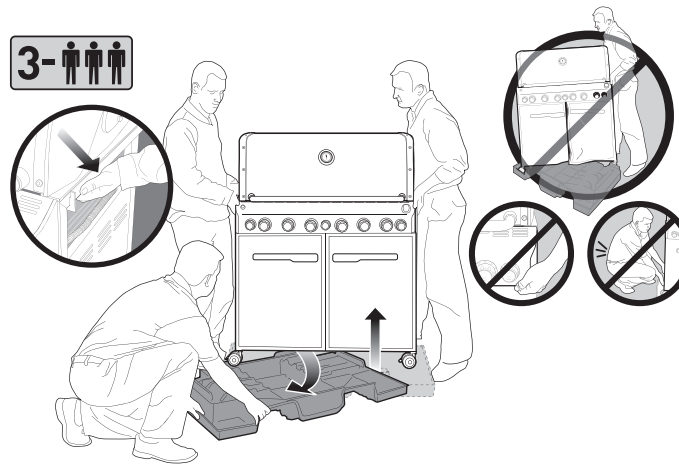

**⚠ IMPORTANT: TO PROPERLY ALIGN FRAME AND DOORS, ASSEMBLE GRILL ON A FLAT AND LEVEL SURFACE.**

**⚠ IMPORTANTE: PARA ALINEAR CORRECTAMENTE EL BASTIDOR Y LAS PUERTAS, ARME LA BARBACOA SOBRE UNA SUPERFICIE PLANA Y HORIZONTAL.**

**⚠ IMPORTANT: POUR ALIGNER CORRECTEMENT LE CHASSIS ET LES PORTES, ASSEMBLEZ LE GRILL SUR UNE SURFACE PLANE ET A NIVEAU.**

- Adjust doors, if necessary
- Si fuese necesario, ajuste la puerta
- Ajustez la porte si nécessaire

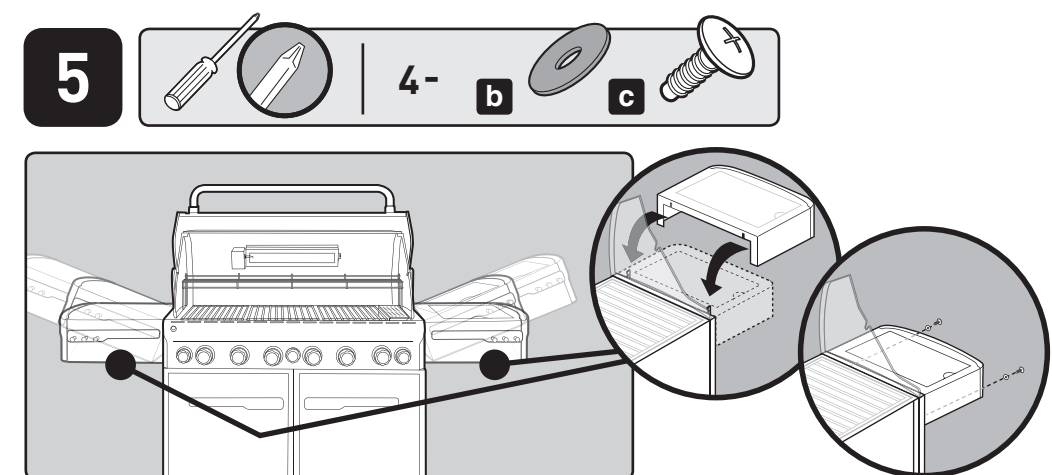
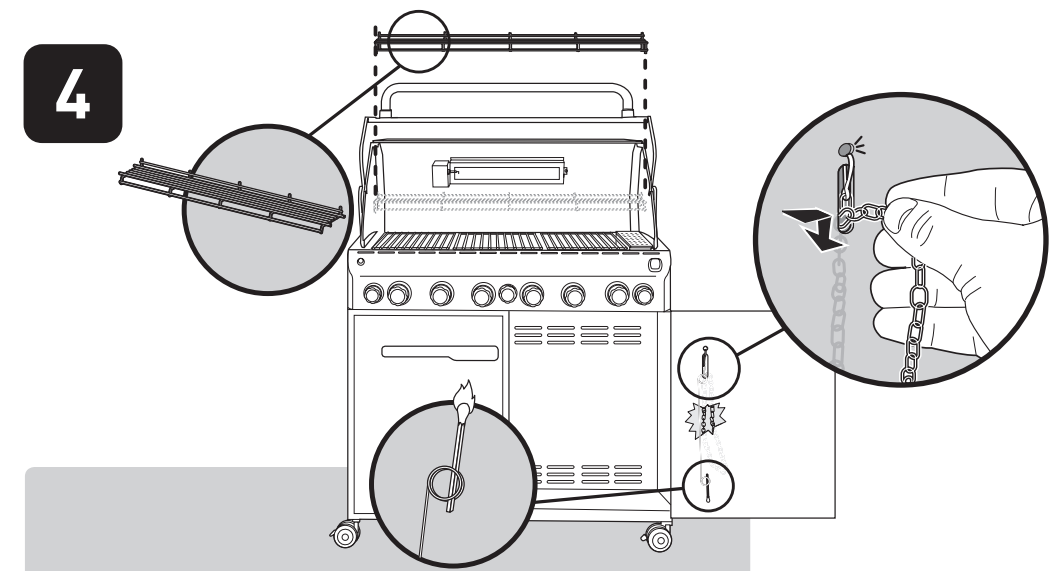
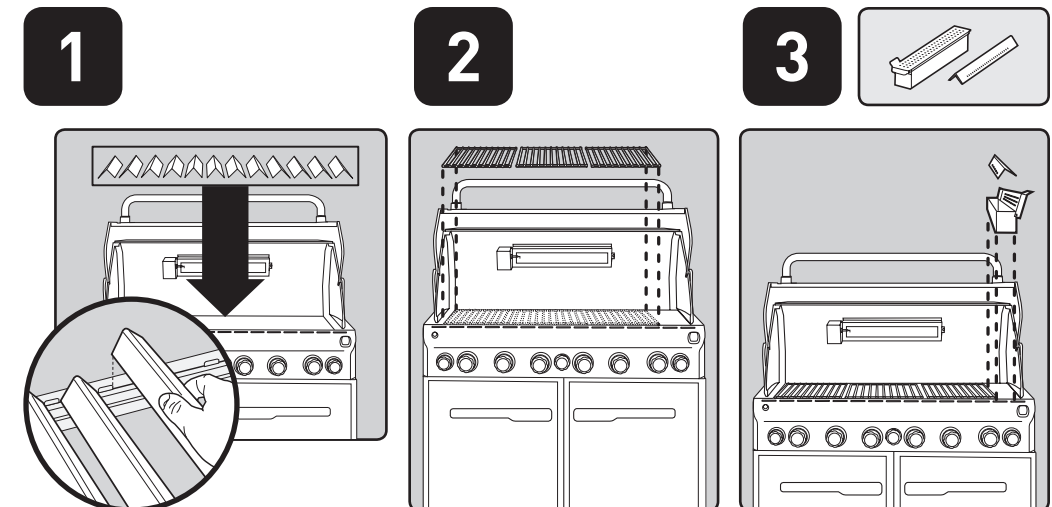
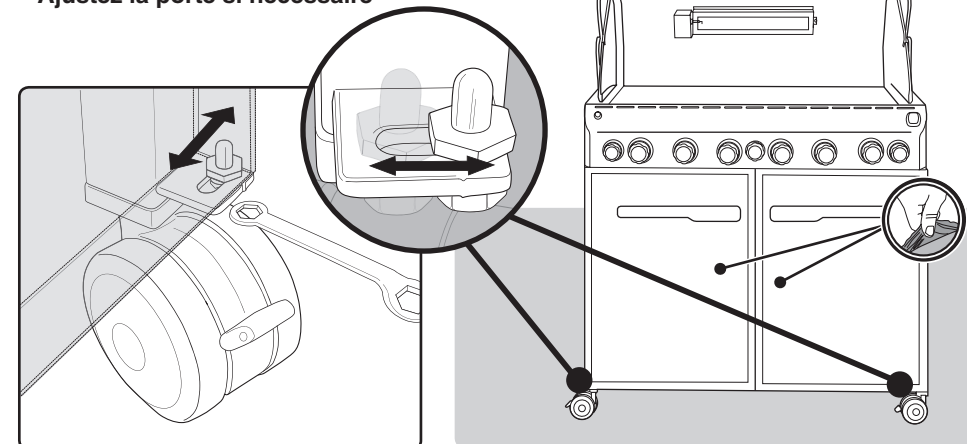



**Hardware:**  
Herrajes:  
Matériel:

**a**

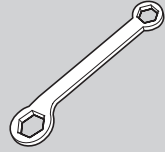

**Wrench - 1**  
Llave - 1  
Clé - 1

**b**



**Nylon Washer - 4**  
Arandela de nilón - 4  
Rondelle de nylon - 4

**c**



**Truss Head Screw**  
(1/4 - 20 x 5/8 inch) - 4  
Tornillo de cabeza segmentada (Tornillo 1/4 - 20 x 5/8 pulgadas) - 4  
Vis à tête bombée large de (1/4 - 20 x 5/8 pouces) - 4

**d**



**Screw - 3**  
Tornillo - 3  
Vis - 3

**e**

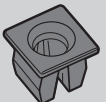

**Plastic Plug - 3**  
Tapón plástico - 3  
Bouchon en plastique - 3



**Before installing component, remove protective film from the stainless steel part.**

**Antes de instalar el componente, retire la película protectora de la pieza de acero inoxidable.**

**Avant d'installer le composant, retirez la pellicule protectrice de la pièce en acier inoxydable.**

**6**

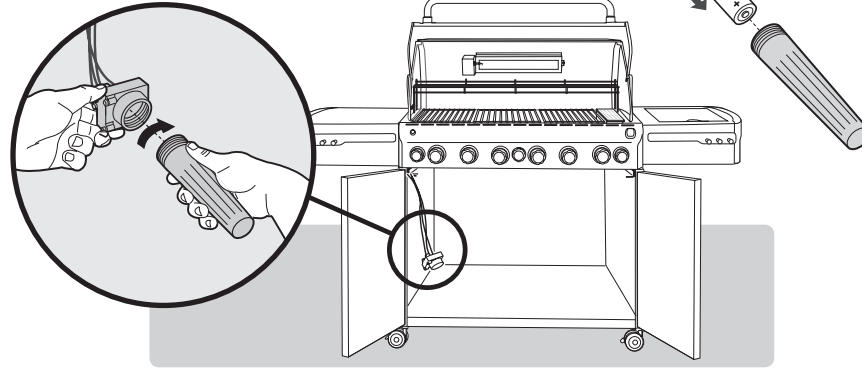
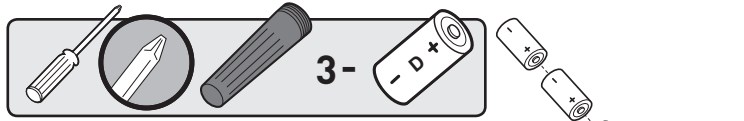

**Requires 3 "D" alkaline batteries (Included).** Use alkaline batteries only. Do not mix old and new batteries or different types of batteries (standard, alkaline or rechargeable).

**Requiere 3 baterías alcalinas "D" (incluidas).** Use solamente baterías alcalinas. No mezcle baterías nuevas con viejas o diferentes tipos de baterías entre sí (normales, alcalinas o recargables).

**Fonctionne avec 3 piles alcalines "D" (Fournies).** Utilisez des piles alcalines uniquement. Ne mélangez pas des piles usagées et des piles neuves ou différents types de piles (ordinaires, alcalines ou rechargeables).

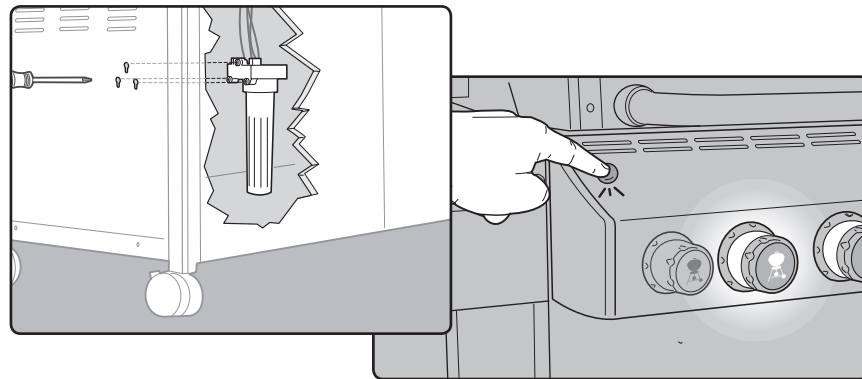

**7**

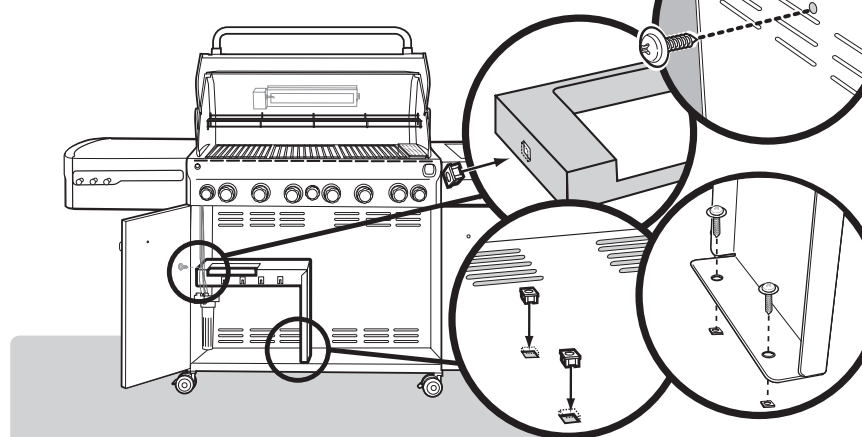

**8**

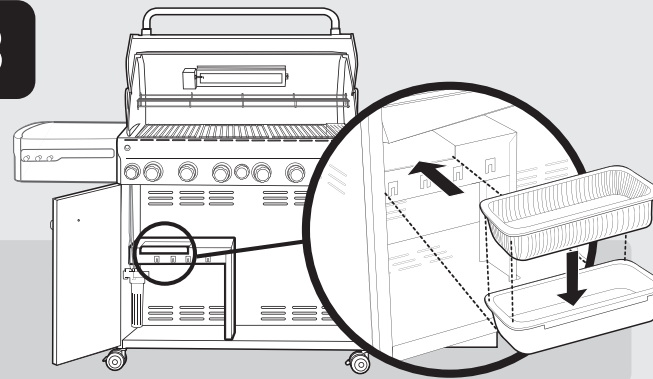

**9**

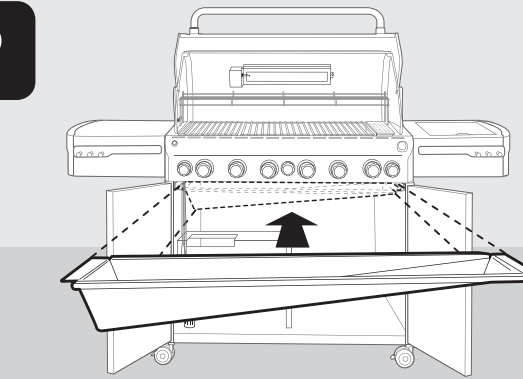

**10**

**See Operating Guide for complete retractable rotisserie operating instructions.**

Consulte la Guía del Propietario para las instrucciones completas acerca del asador giratorio retráctil.

Voir le Mode d'emploi pour des instructions complètes concernant l'utilisation de la rôtisserie rétractable.

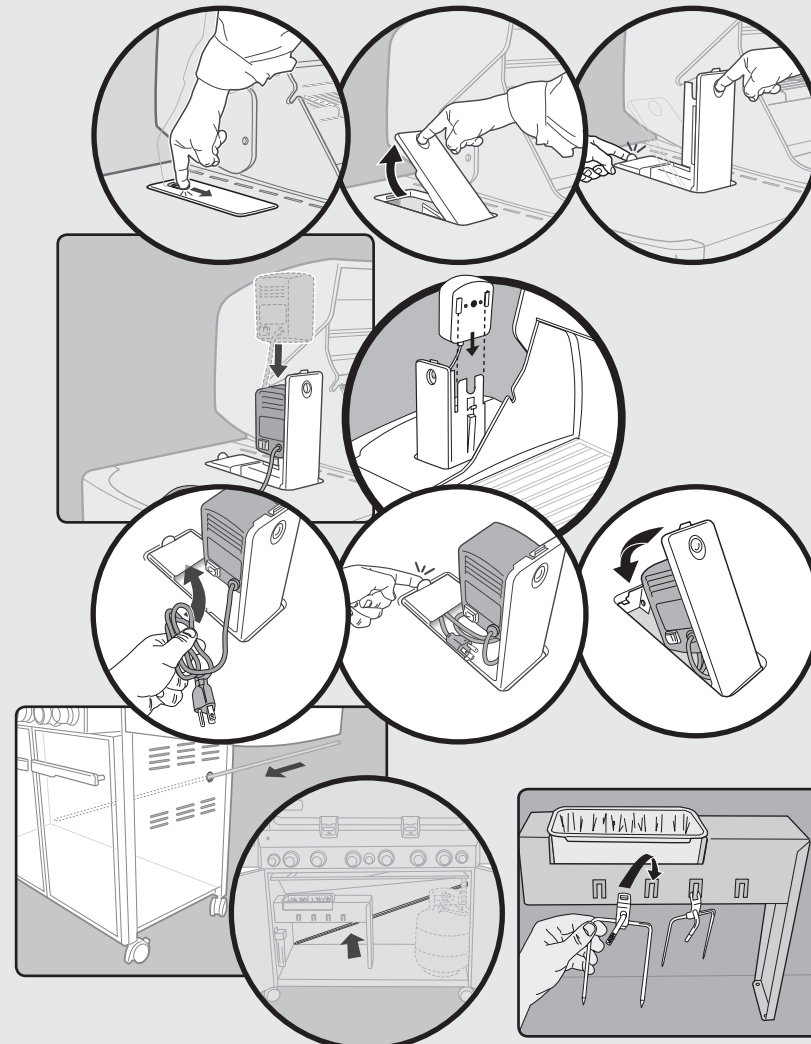

**11**

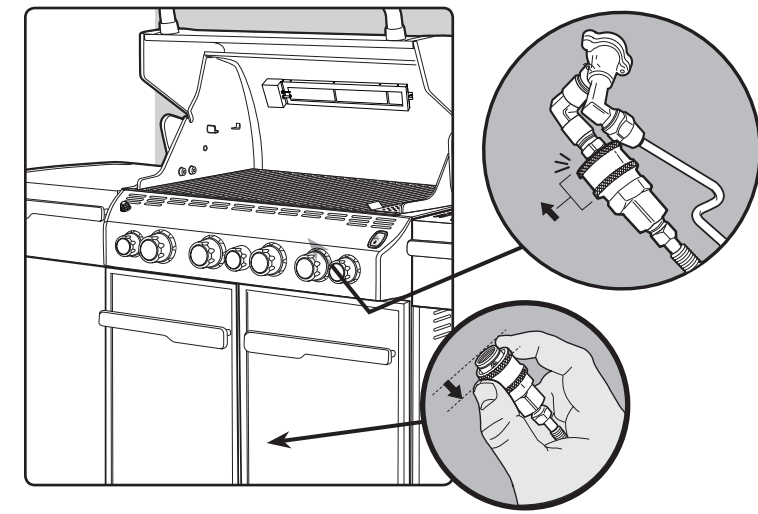

**12**

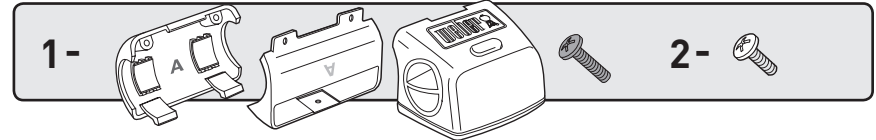

The Weber Grill Out™ Handle Light has a "Tilt Sensor": Lid up - ON / Lid Closed - OFF. The power button (a) activates or deactivates the "Tilt Sensor." For daytime use, deactivate the sensor by pressing power button (a).

La Lámpara de Asa Weber Grill Out™ tiene un "sensor de inclinación": tapa abierta - ENCENDIDA / tapa cerrada - APAGADA. El botón de encendido (a) activa o desactiva al "sensor de inclinación". Para uso durante el día, desactive al sensor pulsando el botón de encendido (a).

La Lampe de poignée Weber Grill Out™ est pourvue d'un "Décteur Tilt" : Couvercle relevé - MARCHÉ / Couvercle fermé - ARRET (OFF). Le bouton d'alimentation électrique (a) active ou désactive le "Décteur Tilt." Pour une utilisation pendant la journée, veuillez désactiver le détecteur en appuyant sur le bouton d'alimentation électrique (a).

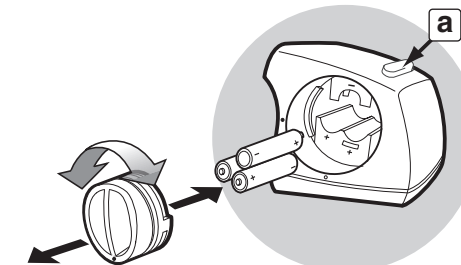

Requires 3 "AAA" alkaline batteries (not included)  
Fonctionne avec 3 piles alcalines "AAA" (non fournies)  
Requiere 3 baterías alcalinas "AAA" (no están incluidas)

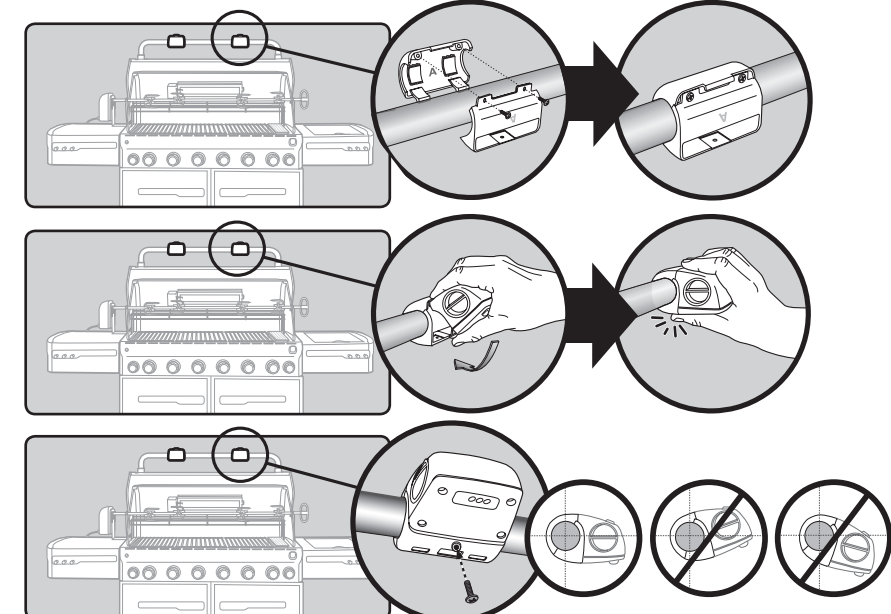

## Free Manuals Download Website

<http://myh66.com>

<http://usermanuals.us>

<http://www.somanuals.com>

<http://www.4manuals.cc>

<http://www.manual-lib.com>

<http://www.404manual.com>

<http://www.luxmanual.com>

<http://aubethermostatmanual.com>

Golf course search by state

<http://golfingnear.com>

Email search by domain

<http://emailbydomain.com>

Auto manuals search

<http://auto.somanuals.com>

TV manuals search

<http://tv.somanuals.com>