



TELEDYNE

ADVANCED POLLUTION INSTRUMENTATION

A Teledyne Technologies Company

INSTRUCTION MANUAL

MODEL 360E CARBON DIOXIDE ANALYZER

© TELEDYNE INSTRUMENTS
ADVANCED POLLUTION INSTRUMENTATION DIVISION
9480 CARROLL PARK DRIVE
SAN DIEGO, CA 92121-5201
USA

Toll-free Phone: 800-324-5190
Phone: 858-657-9800
Fax: 858-657-9816
Email: api-sales@teledyne.com
Website: <http://www.teledyne-api.com/>

Copyright 2008 Teledyne Advanced Pollution
Instrumentation





04584 REV. C8
DCN 5341
06 March 2009

THIS PAGE IS INTENTIONALLY LEFT BLANK

SAFETY MESSAGES

Your safety and the safety of others is very important. We have provided many important safety messages in this manual. Please read these messages carefully.

A safety message alerts you to potential hazards that could hurt you or others. Each safety message is associated with a safety alert symbol. These symbols are found in the manual and inside the instrument. The definition of these symbols is described below:

	GENERAL SAFETY HAZARD: Refer to the instructions for details on the specific hazard.
	CAUTION: Hot Surface Warning
	CAUTION: Electrical Shock Hazard
	TECHNICIAN SYMBOL: All operations marked with this symbol are to be performed by qualified maintenance personnel only.

CAUTION

The analyzer should only be used for the purpose and in the manner described in this manual. If you use the analyzer in a manner other than that for which it was intended, unpredictable behavior could ensue with possible hazardous consequences.

TABLE OF CONTENTS

1. M360E DOCUMENTATION	1
1.1. Using This Manual	1
2. SPECIFICATIONS, APPROVALS AND WARRANTY	3
2.1. Specifications	3
2.2. CE Mark Compliance	4
2.3. Warranty	4
3. GETTING STARTED	7
3.1. Unpacking and Initial Set Up	7
3.1.1. M360 Layout	9
3.1.2. Electrical Connections	12
3.1.2.1. Power Connection	12
3.1.2.2. Output Connections	13
3.1.2.3. Connecting the Status Outputs	14
3.1.2.4. Connecting the Control Inputs	15
3.1.2.5. Connecting the Serial Ports	16
3.1.2.6. Connecting to a LAN or the Internet	16
3.1.2.7. Connecting to a Multidrop Network	16
3.1.3. Pneumatic Connections:	16
3.1.3.1. Basic Pneumatic Connections	16
3.1.3.2. Connections with Internal Valve Options Installed	20
3.1.3.3. Pneumatic Connections to M360E in Multipoint Calibration Applications	22
3.1.4. Setting the internal Purge Air Pressure	22
3.2. Initial Operation	23
3.2.1. Startup	23
3.2.2. Warm Up	24
3.2.3. Warning Messages	24
3.2.4. Functional Check	26
3.3. Initial Calibration Procedure	27
3.3.1. Initial O ₂ Sensor Calibration Procedure	30
3.3.1.1. O ₂ Calibration Setup	30
3.3.1.2. O ₂ Calibration Method	30
4. FREQUENTLY ASKED QUESTIONS	35
4.1. FAQ's	35
4.2. Glossary	36
5. OPTIONAL HARDWARE AND SOFTWARE	39
5.1. Rack Mount Kits (Options 20a, 20b & 21)	39
5.2. Current Loop Analog Outputs (Option 41)	39
5.2.1. Converting Current Loop Analog Outputs to Standard Voltage Outputs	40
5.3. Expendable Kits (Options 42C, 42D and 43)	40
5.4. Calibration Valves Options	41
5.4.1. Zero/Span/Shutoff Valve (Option 50)	41
5.4.2. Zero/Span/Shutoff with External CO ₂ Scrubber (Option 51)	42
5.4.3. Zero/Span Valve (Option 52)	42
5.4.4. Zero/Span Valve with External CO ₂ Scrubber (Option 53)	44
5.5. Communication Options	44
5.5.1. RS232 Modem Cable (Option 60)	44
5.5.2. RS-232 Multidrop (Option 62)	44
5.5.3. Ethernet (Option 63)	45
5.6. Oxygen Sensor (OPT 65)	46
5.6.1. Theory of Operation	46
5.6.1.1. Paramagnetic measurement of O ₂	46
5.6.1.2. Operation within the M360E Analyzer	46
5.6.1.3. Pneumatic Operation of the O ₂ Sensor	47
5.7. Additional Manuals	48
5.7.1. Printed Manuals (Option 70)	48
5.7.2. Manual on CD (Part number 045840200)	48
5.8. Extended Warranty (Options 92 & 93)	48
5.9. Special Software Features	48
5.9.1. Dilution Ratio Option	48
5.9.2. Maintenance Mode Switch	49
5.9.3. Second Language Switch	49

6. OPERATING INSTRUCTIONS	51
6.1. Overview of Operating modes	51
6.2. Sample Mode	52
6.2.1. Test Functions	52
6.2.2. Warning Messages	55
6.3. Calibration Mode	56
6.4. SETUP MODE	57
6.5. SETUP → CFG: Viewing the Analyzer's Configuration Information	58
6.6. SETUP → ACAL: Automatic Calibration	58
6.7. SETUP → DAS: Using the Data Acquisition System (iDAS)	59
6.7.1. iDAS Structure	59
6.7.1.1. iDAS Channels	60
6.7.1.2. iDAS Parameters	61
6.7.1.3. iDAS Triggering Events	62
6.7.2. Default iDAS Channels	62
6.7.2.1. Viewing iDAS Data and Settings	65
6.7.2.2. Editing iDAS Data Channels	66
6.7.2.3. Trigger Events	67
6.7.2.4. Editing iDAS Parameters	68
6.7.2.5. Sample Period and Report Period	70
6.7.2.6. Number of Records	72
6.7.2.7. RS-232 Report Function	73
6.7.2.8. Compact Report	73
6.7.2.9. Starting Date	73
6.7.2.10. Disabling/Enabling Data Channels	74
6.7.2.11. HOLDOFF Feature	74
6.7.3. Remote iDAS Configuration	75
6.8. SETUP → RNGE: Analog Output Reporting Range Configuration	77
6.8.1. Physical Range versus Analog Output Reporting Ranges	77
6.8.2. Reporting Range Modes	78
6.8.3. Single Range mode (SNGL)	79
6.8.4. Dual Range Mode (DUAL)	80
6.8.5. Auto Range Mode (AUTO)	81
6.8.6. Range Units	82
6.8.7. Dilution Ratio	83
6.9. SETUP → PASS: Password Feature	84
6.10. SETUP → CLK: Setting the Internal Time-of-Day Clock	85
6.11. SETUP → MORE → COMM: Using the Analyzer's Communication Ports	86
6.11.1. Analyzer ID	86
6.11.2. COMM Port Default Settings	87
6.11.3. RS-485 Configuration of COM2	89
6.11.4. DTE and DCE Communication	90
6.11.5. COMM Port Communication Modes	91
6.11.6. Ethernet Card Configuration	93
6.11.6.1. Ethernet Card COM2 Communication Modes and Baud Rate	93
6.11.6.2. Configuring the Ethernet Interface Option using DHCP	93
6.11.6.3. Manually Configuring the Network IP Addresses	96
6.11.6.4. Changing the Analyzer's HOSTNAME	98
6.11.7. Multidrop RS-232 Set Up	99
6.11.8. COM Port Baud Rate	101
6.11.9. COM Port Testing	102
6.12. SETUP → MORE → VARS: Internal Variables (VARS)	103
6.13. SETUP → MORE → DIAG: Using the Diagnostics Functions	105
6.13.1. Accessing the Diagnostic Features	106
6.13.2. Signal I/O	106
6.13.3. Analog Output Step Test	107
6.13.4. Analog I/O Configuration	108
6.13.4.1. Analog Output Signal Type and Range Span Selection	110
6.13.4.2. Analog Output Calibration Mode	110
6.13.4.3. Manual Analog Output Calibration and Voltage Adjustment	112
6.13.4.4. Current Loop Output Adjustment	114
6.13.4.5. AIN Calibration	116
6.13.5. Electric Test	117
6.13.6. Dark Calibration Test	118
6.13.7. Pressure Calibration	119

- 6.13.8. Flow Calibration 120
- 6.13.9. Test Channel Output 121
- 6.14. SETUP →MORE → ALRM: Using the Gas Concentration Alarms 122
 - 6.14.1. Setting the Concentration Alarm Limits 122
- 6.15. Remote Operation of the Analyzer 123
 - 6.15.1. Remote Operation Using the External Digital I/O 123
 - 6.15.1.1. Status Outputs 123
 - 6.15.1.2. Control Inputs 125
 - 6.15.2. Remote Operation Using the External Serial I/O 126
 - 6.15.2.1. Terminal Operating Modes 126
 - 6.15.2.2. Help Commands in Terminal Mode 126
 - 6.15.2.3. Command Syntax 127
 - 6.15.2.4. Data Types 127
 - 6.15.2.5. Status Reporting 128
 - 6.15.2.6. Remote Access by Modem 129
 - 6.15.2.7. COM Port Password Security 130
 - 6.15.2.8. APICOM Remote Control Program 131
 - 6.15.3. Additional Communications Documentation 131
 - 6.15.4. Using the M360E with a Hessen Protocol Network 132
 - 6.15.4.1. General Overview of Hessen Protocol 132
 - 6.15.4.2. Hessen COMM Port Configuration 132
 - 6.15.4.3. Activating Hessen Protocol 133
 - 6.15.4.4. Selecting a Hessen Protocol Type 133
 - 6.15.4.5. Setting The Hessen Protocol Response Mode 134
 - 6.15.4.6. Hessen Protocol Gas ID 134
 - 6.15.4.7. Setting Hessen Protocol Status Flags 135
 - 6.15.4.8. Instrument ID Code 136
- 7. CALIBRATION PROCEDURES 137**
 - 7.1. Before Calibration 137
 - 7.1.1. Zero Air and Span Gas 137
 - 7.1.2. Calibration Gas Traceability 138
 - 7.1.3. Data Recording Devices 138
 - 7.2. Manual Calibration without Zero/Span Valves 138
 - 7.3. Manual Calibration Checks 141
 - 7.4. Manual Calibration with Zero/Span Valves 141
 - 7.5. Manual Calibration Checks with Zero/Span Valves 146
 - 7.5.1. Zero/Span Calibration on Auto Range or Dual Ranges 147
 - 7.5.2. Use of Zero/Span Valves with Remote Contact Closure 148
 - 7.6. Automatic Zero/Span Cal/Check (AutoCal) 148
 - 7.6.1. AutoCal with Auto or Dual Reporting Ranges Modes Selected 151
 - 7.7. Calibration Quality 151
- 8. EPA PROTOCOL CALIBRATION 153**
- 9. MAINTENANCE SCHEDULE & PROCEDURES 155**
 - 9.1. Maintenance Schedule 155
 - 9.2. Predicting Failures Using the Test Functions 158
 - 9.3. Maintenance Procedures 159
 - 9.3.1. Replacing the Sample Particulate Filter 159
 - 9.3.2. Rebuilding the Sample Pump 159
 - 9.3.3. Performing Leak Checks 160
 - 9.3.3.1. Vacuum Leak Check and Pump Check 160
 - 9.3.3.2. Pressure Leak Check 160
 - 9.3.4. Performing a Sample Flow Check 161
 - 9.3.5. Cleaning the Optical Bench 161
 - 9.3.6. Cleaning Exterior Surfaces of the M360E 161
- 10. THEORY OF OPERATION 163**
 - 10.1. Measurement Method 163
 - 10.1.1. Beer's Law 163
 - 10.1.2. Measurement Fundamentals 163
 - 10.1.3. Gas Filter Correlation 164
 - 10.1.3.1. The GFC Wheel 164
 - 10.1.3.2. The Measure Reference Ratio 165
 - 10.1.4. Interference and Signal to Noise Rejection 166
 - 10.1.4.1. Ambient CO₂ Interference Rejection 167
 - 10.2. Pneumatic Operation 168

10.2.1. Sample Gas Flow	168
10.2.2. Flow Rate Control	169
10.2.2.1. Critical Flow Orifice	169
10.2.3. Purge Gas Pressure Control	170
10.2.4. Particulate Filter	170
10.2.5. Pneumatic Sensors	170
10.2.5.1. Sample Pressure Sensor	170
10.2.5.2. Sample Flow Sensor	170
10.3. Electronic Operation	171
10.3.1. Overview	171
10.3.2. CPU	173
10.3.3. Optical Bench & GFC Wheel	173
10.3.3.1. Temperature Control	173
10.3.3.2. IR Source	173
10.3.3.3. GFC Wheel	174
10.3.3.4. IR Photo-Detector	175
10.3.4. Synchronous Demodulator (Sync/Demod) Assembly	175
10.3.4.1. Overview	175
10.3.4.2. Signal Synchronization and Demodulation	176
10.3.4.3. Sync/Demod Status LED's	177
10.3.4.4. Photo-Detector Temperature Control	178
10.3.4.5. Dark Calibration Switch	178
10.3.4.6. Electric Test Switch	178
10.3.5. Relay Board	178
10.3.5.1. Status LED's	179
10.3.5.2. I ² C Watch Dog Circuitry	180
10.3.6. Mother Board	180
10.3.6.1. A to D Conversion	180
10.3.6.2. Sensor Inputs	180
10.3.6.3. Thermistor Interface	181
10.3.6.4. Analog Outputs	181
10.3.6.5. Internal Digital I/O	182
10.3.6.6. External Digital I/O	182
10.3.7. I ² C Data Bus	182
10.3.8. Power Supply/ Circuit Breaker	183
10.4. Interface	184
10.4.1. Front Panel Interface	184
10.4.1.1. Analyzer Status LED's	185
10.4.1.2. Keyboard	185
10.4.1.3. Display	185
10.4.1.4. Keyboard/Display Interface Electronics	186
10.5. Software Operation	188
10.5.1. Adaptive Filter	188
10.5.2. Calibration - Slope and Offset	189
10.5.3. Measurement Algorithm	189
10.5.4. Temperature and Pressure Compensation	189
10.5.5. Internal Data Acquisition System (iDAS)	190
11. TROUBLESHOOTING & REPAIR PROCEDURES	191
11.1. General Troubleshooting Hints	191
11.1.1. Interpreting WARNING Messages	192
11.1.2. Fault Diagnosis with TEST Functions	194
11.1.3. Using the Diagnostic Signal I/O Function	196
11.1.4. Internal Electronic Status LED's	197
11.1.4.1. CPU Status Indicator	197
11.1.4.2. Sync Demodulator Status LED's	197
11.1.4.3. Relay Board Status LED's	198
11.2. Gas Flow Problems	200
11.2.1. M360E Internal Gas Flow Diagrams	200
11.2.2. Typical Sample Gas Flow Problems	202
11.2.2.1. Flow is Zero	202
11.2.2.2. Low Flow	203
11.2.2.3. High Flow	203
11.2.2.4. Displayed Flow = "XXXX"	203
11.2.2.5. Actual Flow Does Not Match Displayed Flow	203
11.2.2.6. Sample Pump	204

11.2.3. Poor or Stopped Flow of Purge Gas	204
11.3. Calibration Problems	204
11.3.1. Miscalibrated.....	204
11.3.2. Non-Repeatable Zero and Span	205
11.3.3. Inability to Span – No SPAN Key.....	205
11.3.4. Inability to Zero – No ZERO Key.....	205
11.4. Other Performance Problems	206
11.4.1. Temperature Problems	206
11.4.1.1. Box or Sample Temperature	206
11.4.1.2. Bench Temperature	206
11.4.1.3. GFC Wheel Temperature.....	207
11.4.1.4. IR Photo-Detector TEC Temperature.....	207
11.4.2. Excessive Noise	208
11.5. Subsystem Checkout.....	209
11.5.1. AC Mains Configuration.....	209
11.5.2. DC Power Supply	209
11.5.3. I ² C Bus.....	210
11.5.4. Keyboard/Display Interface.....	210
11.5.5. Relay Board	211
11.5.6. Sensor Assembly.....	211
11.5.6.1. Sync/Demodulator Assembly.....	211
11.5.6.2. Opto Pickup Assembly.....	212
11.5.6.3. GFC Wheel Drive.....	212
11.5.6.4. IR Source.....	212
11.5.6.5. Pressure/Flow Sensor Assembly	212
11.5.7. Motherboard	213
11.5.7.1. A/D Functions	213
11.5.7.2. Analog Outputs: Voltage	213
11.5.7.3. Analog Outputs: Current Loop	214
11.5.7.4. Status Outputs	215
11.5.7.5. Control Inputs – Remote Zero, Span	215
11.5.8. CPU	216
11.5.9. RS-232 Communications	216
11.5.9.1. General RS-232 Troubleshooting	216
11.5.9.2. Troubleshooting Analyzer/Modem or Terminal Operation.....	217
11.6. Repair Procedures.....	218
11.6.1. Repairing Sample Flow Control Assembly.....	218
11.6.2. Removing/Replacing the GFC Wheel	219
11.6.3. Disk-On-Chip Replacement Procedure.....	220
12. A PRIMER ON ELECTRO-STATIC DISCHARGE.....	221
12.1. How Static Charges are Created.....	221
12.2. How Electro-Static Charges Cause Damage.....	222
12.3. Common Myths About ESD Damage	223
12.4. Basic Principles of Static Control.....	223
12.4.1. General Rules.....	223
12.4.2. Basic anti-ESD Procedures for Analyzer Repair and Maintenance	225
12.4.2.1. Working at the Instrument Rack.....	225
12.4.2.2. Working at an Anti-ESD Work Bench.....	225
12.4.2.3. Transferring Components from Rack to Bench and Back	226
12.4.2.4. Opening Shipments from Teledyne Instruments Customer Service.....	226
12.4.2.5. Packing Components for Return to Teledyne Instruments Customer Service.....	227

LIST OF APPENDICES

APPENDIX A - VERSION SPECIFIC SOFTWARE DOCUMENTATION

- APPENDIX A-1: M360E Software Menu Trees, Revision G.4
- APPENDIX A-2: Setup Variables For Serial I/O, Revision G.4
- APPENDIX A-3: Warnings and Test Functions, Revision G.4
- APPENDIX A-4: M360E Signal I/O Definitions, Revision G.4
- APPENDIX A-5: M360E iDAS Functions, Revision G.4
- APPENDIX A-6: Terminal Command Designators, Revision G.4

APPENDIX B - M360E SPARE PARTS LIST

APPENDIX C - REPAIR QUESTIONNAIRE - M360E

APPENDIX D - ELECTRONIC SCHEMATICS

LIST OF FIGURES

Figure 3-1:	Front Panel Layout.....	9
Figure 3-2:	Rear Panel Layout	9
Figure 3-3:	Assembly Layout.....	10
Figure 3-4:	Optical Bench Layout.....	11
Figure 3-5:	M360E Internal Gas Flow.....	11
Figure 3-6:	Pneumatic Connections–Basic Configuration–Using Bottled Span Gas	17
Figure 3-7:	Pneumatic Connections–Basic Configuration–Using Gas Dilution Calibrator	18
Figure 3-8:	Pneumatic Connections–M360E with Zero/Span/Shutoff Valves (OPT 50).....	20
Figure 3-9:	Pneumatic Connections–M360E with Zero/Span/Shutoff Valves and External Zero Air Scrubber (OPT 51)	20
Figure 3-10:	Pneumatic Connections–M360E with Zero/Span Valves (OPT 52)	21
Figure 3-11:	Pneumatic Connections–M360E with Zero/Span Valves with External Zero air Scrubber (OPT 53).....	21
Figure 3-12:	Example of Pneumatic Set up for Multipoint Calibration of M360.....	22
Figure 3-13:	O ₂ Sensor Calibration Set Up	30
Figure 5-1:	Current Loop Option Installed on the Motherboard	39
Figure 5-2:	Internal Pneumatic Flow – Zero/Span/Shutoff Valves OPT 50 & 51	42
Figure 5-3:	Internal Pneumatic Flow – Zero/Span OPT 52 & 53.....	43
Figure 5-4:	M360E Multidrop Card	44
Figure 5-5:	M360E Ethernet Card	45
Figure 5-6:	M360E Rear Panel with Ethernet Installed	45
Figure 5-2:	Oxygen Sensor - Principle of Operation	46
Figure 5-3:	M360E – Internal Pneumatics with O ₂ Sensor Option 65	47
Figure 6-1:	Front Panel Display.....	51
Figure 6-3:	Viewing M360E TEST Functions	54
Figure 6-3:	Viewing and Clearing M360E WARNING Messages.....	56
Figure 6-4:	Default iDAS Channels Setup	63
Figure 6-5:	APICOM user interface for configuring the iDAS.....	75
Figure 6-6:	iDAS Configuration Through a Terminal Emulation Program.....	76
Figure 6-7:	Analog Output Connector Pin Out	77
Figure 6-8:	Back Panel connector Pin-Outs for COM1 & COM2 in RS-232 mode.....	87
Figure 6-9:	CPU connector Pin-Outs for COM1 & COM2 in RS-232 mode.....	88
Figure 6-10:	CPU card Locations of RS-232/485 Switches, Connectors and Jumpers.....	89
Figure 6-11:	Back Panel connector Pin-Outs for COM2 in RS-485 mode.....	90
Figure 6-12:	CPU connector Pin-Outs for COM2 in RS-485 mode.....	90
Figure 6-13:	Location of JP2 on RS232-Multidrop PCA (option 62)	99
Figure 6-14:	RS232-Multidrop PCA Host/Analyzer Interconnect Diagram.....	100
Figure 6-15:	Setup for Calibrating Analog Voltage Outputs	113
Figure 6-16:	Setup for Calibrating Current Outputs.....	114
Figure 6-17:	Status Output Connector.....	123
Figure 6-18:	Control Inputs.....	125

Figure 6-19: APICOM Remote Control Program Interface.....	131
Figure 7-1: Pneumatic Connections–Basic Configuration–Using Bottled Span Gas.....	138
Figure 7-2: Pneumatic Connections–Basic Configuration–Using Gas Dilution Calibrator.....	139
Figure 7-3: Pneumatic Connections–M360E with Zero/Span/Shutoff Valves (OPT 50).....	142
Figure 7-4: Pneumatic Connections–M360E with Zero/Span/Shutoff Valves and External Zero Air Scrubber (OPT 51).....	142
Figure 7-5: Pneumatic Connections–M360E with Zero/Span Valves (OPT 52).....	143
Figure 7-6: Pneumatic Connections–M360E with Zero/Span Valves with External Zero air Scrubber (OPT 53).....	143
Figure 9-1: Sample Particulate Filter Assembly.....	159
Figure 10-1: Measurement Fundamentals.....	164
Figure 10-2: GFC Wheel.....	164
Figure 10-3: Measurement Fundamentals with GFC Wheel.....	165
Figure 10-4: Affect of CO ₂ in the Sample on CO ₂ MEAS & CO ₂ REF.....	166
Figure 10-5: Effects of Interfering Gas on CO ₂ MEAS & CO ₂ REF.....	166
Figure 10-6: Chopped IR Signal.....	167
Figure 10-7: Internal Pneumatic Flow – Basic Configuration.....	168
Figure 10-8: Flow Control Assembly & Critical Flow Orifice.....	169
Figure 10-9: 360E Electronic Block Diagram.....	172
Figure 10-10: GFC Light Mask.....	174
Figure 10-11: Segment Sensor and M/R Sensor Output.....	175
Figure 10-12: 360E Sync / Demod Block Diagram.....	176
Figure 10-13: Sample & Hold Timing.....	177
Figure 10-14: Location of relay board Status LED's.....	180
Figure 10-15: Power Distribution Block Diagram.....	183
Figure 10-16: Interface Block Diagram.....	184
Figure 10-17: M360E Front Panel Layout.....	184
Figure 10-18: Keyboard and Display Interface Block Diagram.....	186
Figure 10-19: Basic Software Operation.....	188
Figure 11-1: Viewing and Clearing Warning Messages.....	192
Figure 11-2: Example of Signal I/O Function.....	196
Figure 11-3: CPU Status Indicator.....	197
Figure 11-4: Sync/Demod Board Status LED Locations.....	198
Figure 11-5: Relay Board Status LEDs.....	198
Figure 11-7: M360E – Basic Internal Gas Flow.....	200
Figure 11-6: Internal Pneumatic Flow OPT 50– Zero/Span/Shutoff Valves.....	201
Figure 11-8: Internal Pneumatic Flow – Zero/Span OPT 52 & 53.....	201
Figure 11.9: M360E – Internal Pneumatics with O ₂ Sensor Option 65.....	202
Figure 11-10: Critical Flow Restrictor Assembly Disassembly.....	218
Figure 11-11: Opening the GFC Wheel Housing.....	219
Figure 11-12: Removing the GFC Wheel.....	220
Figure 12-1: Triboelectric Charging.....	221
Figure 12-2: Basic anti-ESD Work Station.....	223

LIST OF TABLES

Table 2-1: Model 360E Basic Unit Specifications.....	3
Table 3-1: M360E Analog Output Pin Outs.....	13
Table 3-2: M360E Status Output Pin Outs.....	14
Table 3-3: M360E Control Input Pin Outs.....	15
Table 3-4: Model 360E Rear Panel Pneumatic Connections.....	17
Table 3-5: Front Panel Display During System Warm-Up.....	24
Table 3-6: Possible Warning Messages at Start-Up.....	25
Table 5-1: Zero/Span Valve Operating States for Options 50 & 51.....	41
Table 5-2: Zero/Span Valve Operating States for Options 52 & 53.....	43
Table 6-1: Analyzer Operating modes.....	52
Table 6-2: Test Functions Defined.....	53

Table 6-3:	List of Warning Messages.....	55
Table 6-4:	Primary Setup Mode Features and Functions.....	57
Table 6-5:	Secondary Setup Mode Features and Functions.....	57
Table 6-6:	Front Panel LED Status Indicators for iDAS.....	59
Table 6-7:	iDAS Data Channel Properties.....	60
Table 6-8:	iDAS Data Parameter Functions.....	61
Table 6-9:	Password Levels.....	84
Table 6-10:	COMM Port Communication modes.....	91
Table 6-11:	Ethernet Status Indicators.....	93
Table 6-12:	LAN/Internet Configuration Properties.....	94
Table 6-13:	Internet Configuration Keypad Functions.....	98
Table 6-14:	Variable Names (VARS) Revision B.3.....	103
Table 6-15:	M360E Diagnostic (DIAG) Functions.....	105
Table 6-16:	DIAG - Analog I/O Functions.....	108
Table 6-17:	Analog Output Voltage Ranges.....	108
Table 6-18:	Analog Output Current Loop Range.....	109
Table 6-19:	Analog Output Pin Assignments.....	109
Table 6-20:	Voltage Tolerances for Analog Output Calibration.....	112
Table 6-21:	Current Loop Output Calibration with Resistor.....	115
Table 6-22:	Test Parameters Available for Analog Output A4.....	121
Table 6-23:	CO ₂ Concentration Alarm Default Settings.....	122
Table 6-24:	Status Output Pin Assignments.....	124
Table 6-25:	Control Input Pin Assignments.....	125
Table 6-26:	Terminal Mode Software Commands.....	126
Table 6-27:	Command Types.....	127
Table 6-28:	Serial Interface Documents.....	131
Table 6-29:	RS-232 Communication Parameters for Hessen Protocol.....	132
Table 6-30:	Teledyne Instruments Hessen Protocol Response Modes.....	134
Table 6-31:	Default Hessen Status Bit Assignments.....	135
Table 7-1:	AUTOCAL Modes.....	148
Table 7-2:	AutoCal ATTRIBUTE Setup Parameters.....	148
Table 7-3:	Calibration Data Quality Evaluation.....	151
Table 9-1:	M360E Maintenance Schedule.....	156
Table 9-2:	M360E Test Function Record.....	157
Table 9-3:	Predictive uses for Test Functions.....	158
Table 10-1:	Sync/Demod Status LED Activity.....	177
Table 10-2:	Relay Board Status LED's.....	179
Table 10-3:	Front Panel Status LED's.....	185
Table 11-1:	Warning Messages - Indicated Failures.....	193
Table 11-2:	Test Functions - Indicated Failures.....	195
Table 11-3:	Sync/Demod Board Status Failure Indications.....	197
Table 11-4:	I ² C Status LED Failure Indications.....	198
Table 11-5:	Relay Board Status LED Failure Indications.....	199
Table 11-6:	DC Power Test Point and Wiring Color Codes.....	209
Table 11-7:	DC Power Supply Acceptable Levels.....	210
Table 11-8:	Relay Board Control Devices.....	211
Table 11-9:	Opto Pickup Board Nominal Output Frequencies.....	212
Table 11-10:	Analog Output Test Function - Nominal Values Voltage Outputs.....	214
Table 11-11:	Analog Output Test Function - Nominal Values Current Outputs.....	214
Table 11-12:	Status Outputs Check.....	215
Table 12-1:	Static Generation Voltages for Typical Activities.....	221
Table 12-2:	Sensitivity of Electronic Devices to Damage by ESD.....	222

User Notes

1. M360E DOCUMENTATION

Thank you for purchasing the Model 300E Gas Filter Correlation Carbon monoxide Analyzer!

The documentation (part number 04584) for this instrument is available in several different formats:

- Printed format, or;
- Electronic format on a CD-ROM.

The electronic manual is in Adobe® Systems Inc. "Portable Document Format". The Adobe® Acrobat Reader® software, which is necessary to view these files, can be downloaded for free from the internet at <http://www.adobe.com/>.

The electronic version of the manual has many advantages:

- Keyword and phrase search feature
- Figures, tables and internet addresses are linked so that clicking on the item will display the associated feature or open the website.
- A list of chapters as well as thumbnails of each page is displayed to the left of the text.
- Entries in the table of contents are linked to the corresponding locations in the manual.
- Ability to print s (or all) of the manual

Additional documentation for the Model 360E CO₂ Analyzer is available from Teledyne Instruments' website at <http://www.teledyne-api.com/manuals/>

- APICOM software manual, part number 03945
- Multi-drop manual, part number 01842
- DAS Manual, part number 02837.

1.1. Using This Manual

This manual has the following data structures:

1.0 TABLE OF CONTENTS:

Outlines the contents of the manual in the order the information is presented. This is a good overview of the topics covered in the manual. There is also a list of tables, a list of figures and a list of appendices. In the electronic version of the manual, clicking on any of these table entries automatically views that section.

2.0 SPECIFICATIONS AND WARRANTY

This section contains a list of the analyzer's performance specifications, a description of the conditions and configuration under which EPA equivalency was approved and Teledyne Instruments Incorporated's warranty statement.

3.0 GETTING STARTED:

A concise set of instructions for setting up, installing and running your analyzer for the first time.

4.0 FAQ:

Answers to the most frequently asked questions about operating the analyzer.

5.0 OPTIONAL HARDWARE & SOFTWARE

A description of optional equipment to add functionality to your analyzer.

6.0 OPERATION INSTRUCTIONS

This section includes step-by-step instructions for operating the analyzer and using its various features and functions.

7.0 CALIBRATION PROCEDURES

General information and step by step instructions for calibrating your analyzer.

8.0 EPA PROTOCOL CALIBRATION

Because CO₂ is not declared a criteria air pollutant by the US EPA, EPA equivalency is not required for this type of analyzer. Therefore no special calibration methods are needed to satisfy EPA requirements.

9.0 INSTRUMENT MAINTENANCE

Description of certain preventative maintenance procedures that should be regularly performed on you instrument to keep it in good operating condition. This section also includes information on using the iDAS to record diagnostic functions useful in predicting possible component failures before they happen.

10.0 THEORY OF OPERATION

An in-depth look at the various principals by which your analyzer operates as well as a description of how the various electronic, mechanical and pneumatic components of the instrument work and interact with each other. A close reading of this section is invaluable for understanding the instrument's operation.

11.0 TROUBLESHOOTING:

This section includes pointers and instructions for diagnosing problems with the instrument, such as excessive noise or drift, as well as instructions on performing repairs of the instrument's major subsystems.

APPENDICES:

For easier access and better updating, some information has been separated out of the manual and placed in a series of appendices at the end of this manual. These include: software menu trees, warning messages, definitions of iDAS & serial I/O variables, spare parts list, repair questionnaire, interconnect listing and drawings, and electronic schematics.

NOTE

Throughout this manual, words printed in capital, bold letters, such as SETUP or ENTR represent messages as they appear on the analyzer's front panel display.

NOTE

The flowcharts in this manual contain typical representations of the analyzer's display during the various operations being described. These representations are not intended to be exact and may differ slightly from the actual display of your instrument.

User Notes

2. SPECIFICATIONS, APPROVALS AND WARRANTY

2.1. Specifications

Table 2-1: Model 360E Basic Unit Specifications

Min/Max Range (Physical Analog Output)	In 1ppb increments from 50ppb to 2 000ppm, dual ranges or auto ranging
Measurement Units	ppb, ppm, $\mu\text{g}/\text{m}^3$, mg/m^3 , %(user selectable)
Zero Noise	< 0.1 ppm (RMS)
Span Noise	< 1% of reading (RMS)
Lower Detectable Limit ¹	< 0.2 ppm ¹
Zero Drift (24 hours)	<0.25 ppm ¹
Zero Drift (7 days)	<0.5 ppm ¹
Span Drift (7 Days)	1% of reading above 50 PPM ¹
Linearity	1% of full scale
Precision	0.5% of reading
Temperature Coefficient	< 0.1% of Full Scale per °C
Voltage Coefficient	< 0.05% of Full Scale per V
Lag Time	10 sec
Rise/Fall Time	95% in <60 sec
Sample Flow Rate	800cm ³ /min. \pm 10% O ₂ Sensor option adds 120 cm ³ /min to total flow though when installed;
Temperature Range	5-40°C
Humidity Range	0 - 95% RH, non-condensing
Dimensions H x W x D	7" x 17" x 23.5" (178 mm x 432 mm x 597 mm)
Weight, Analyzer	38 lbs. (17 kg); add 1 lbs (0.5 kg) for IZS
AC Power Rating	100 V, 50/60 Hz (3.25A); 115 V, 60 Hz (3.0 A); 220 – 240 V, 50/60 Hz (2.5 A)
Environmental	Installation category (over-voltage category) II; Pollution degree 2
Analog Outputs	Three (3) Outputs
Analog Output Ranges	0.1V, 1 V, 5 V, 10 V, 2-20 or 4-20 mA isolated current loop. All Ranges with 5% Under/Over Range
Analog Output Resolution	1 part in 4096 of selected full-scale voltage
Status Outputs	8 Status outputs - opto-isolated; including 2 alarm outputs
Control Inputs	6 Control Inputs, 3 defined, 3 spare
Serial I/O	One (1) RS-232; One (1) RS-485 Baud Rate : 300 – 115200: Optional Ethernet Interface
Alarm outputs	2 opto-isolated alarms outputs with user settable alarm limits
Certifications	CE: EN61010-1:90 + A1:92 + A2:95, EN61326 - Class A
¹ At constant temperature and voltage.	

2.2. CE Mark Compliance

Emissions Compliance

The Teledyne Instruments Model 360E Gas Filter Correlation CO₂ Analyzer was tested and found to be fully compliant with:

EN61326 (1997 w/A1: 98) Class A, FCC Part 15 Subpart B section 15.107 Class A, ICES-003 Class A (ANSI C63.4 1992) & AS/NZS 3548 (w/A1 & A2; 97) Class A.

Tested on 11-29-2001 at CKC Laboratories, Inc., Report Number CE01-249.

Safety Compliance

The Teledyne Instruments Model 360E Gas Filter Correlation CO₂ Analyzer was tested and found to be fully compliant with:

IEC 61010-1:90 + A1:92 + A2:95,

Tested on 02-06-2002 at Nemko, Report Number 2002-012219.

2.3. Warranty

WARRANTY POLICY (02024D)

Prior to shipment, T-API equipment is thoroughly inspected and tested. Should equipment failure occur, T-API assures its customers that prompt service and support will be available.

COVERAGE

After the warranty period and throughout the equipment lifetime, T-API stands ready to provide on-site or in-plant service at reasonable rates similar to those of other manufacturers in the industry. All maintenance and the first level of field troubleshooting is to be performed by the customer.

NON-API MANUFACTURED EQUIPMENT

Equipment provided but not manufactured by T-API is warranted and will be repaired to the extent and according to the current terms and conditions of the respective equipment manufacturer's warranty.

GENERAL

During the warranty period, T-API warrants each Product manufactured by T-API to be free from defects in material and workmanship under normal use and service. Expendable parts are excluded.

If a Product fails to conform to its specifications within the warranty period, API shall correct such defect by, in API's discretion, repairing or replacing such defective Product or refunding the purchase price of such Product.

The warranties set forth in this section shall be of no force or effect with respect to any Product: (i) that has been altered or subjected to misuse, negligence or accident, or (ii) that has been used in any manner other than in accordance with the instruction provided by T-API, or (iii) not properly maintained.

THE WARRANTIES SET FORTH IN THIS SECTION AND THE REMEDIES THEREFORE ARE EXCLUSIVE AND IN LIEU OF ANY IMPLIED WARRANTIES OF MERCHANTABILITY, FITNESS FOR PARTICULAR PURPOSE OR OTHER WARRANTY OF QUALITY, WHETHER EXPRESSED OR IMPLIED. THE REMEDIES SET FORTH IN THIS SECTION ARE THE EXCLUSIVE REMEDIES FOR BREACH OF ANY WARRANTY CONTAINED HEREIN. API SHALL NOT BE LIABLE FOR ANY INCIDENTAL OR CONSEQUENTIAL DAMAGES ARISING OUT OF OR RELATED TO THIS AGREEMENT OF T-API'S PERFORMANCE HEREUNDER, WHETHER FOR BREACH OF WARRANTY OR OTHERWISE

Terms and Conditions

All units or components returned to Teledyne Instruments Incorporated should be properly packed for handling and returned freight prepaid to the nearest designated Service Center. After the repair, the equipment will be returned, freight prepaid.

User Notes

3. GETTING STARTED

3.1. Unpacking and Initial Set Up



CAUTION

To avoid personal injury, always use two persons to lift and carry the Model 360E.

1. Verify that there is no apparent external shipping damage. If damage has occurred, please advise the shipper first, then Teledyne Instruments.
2. Included with your analyzer is a printed record of the final performance characterization performed on your instrument at the factory. This record, titled Final Test and Validation Data Sheet (P/N 04596) is an important quality assurance and calibration record for this instrument. It should be placed in the quality records file for this instrument.
3. Carefully remove the top cover of the analyzer and check for internal shipping damage.
 - Remove the set-screw located in the top, center of the Front panel.
 - Remove the 2 screws fastening the top cover to the unit (one per side towards the rear).
 - Slide the cover backwards until it clears the analyzer's front bezel.
 - Lift the cover straight up.

NOTE

Some versions of the 360E CO₂ Analyzer may have a spring loaded fastener at the top center of the rear panel and as many as eight screws (four per side) fastening the top cover to the chassis.

NOTE

Printed circuit assemblies (PCAs) are sensitive to electro-static discharges too small to be felt by the human nervous system. Failure to use ESD protection when working with electronic assemblies will void the instrument warranty.

See Chapter 12 for more information on preventing ESD damage.



CAUTION

Never disconnect PCAs, wiring harnesses or electronic subassemblies while under power.

4. Inspect the interior of the instrument to make sure all circuit boards and other components are in good shape and properly seated.

5. Check the connectors of the various internal wiring harnesses and pneumatic hoses to make sure they are firmly and properly seated.
6. Verify that all of the optional hardware ordered with the unit has been installed. These are listed on the paperwork accompanying the analyzer.
7. **VENTILATION CLEARANCE:** Whether the analyzer is set up on a bench or installed into an instrument rack, be sure to leave sufficient ventilation clearance.

AREA	MINIMUM REQUIRED CLEARANCE
Back of the instrument	4 in.
Sides of the instrument	1 in.
Above and below the instrument	1 in.

- Various rack mount kits are available for this analyzer. See Section [Rack Mount Option](#) 5.1 of this manual for more information.

3.1.1. M360 Layout

Figure 3-1 shows the front panel layout of the analyzer. Figure 3-2 shows the rear panel configuration with optional zero-air scrubber mounted to it and two optional fittings for the IZS option.

Figure 3-3 shows a top-down view of the analyzer. The shown configuration includes the Ethernet board, IZS option, zero-air scrubber and an additional sample dryer. See Chapter 5 for optional equipment.

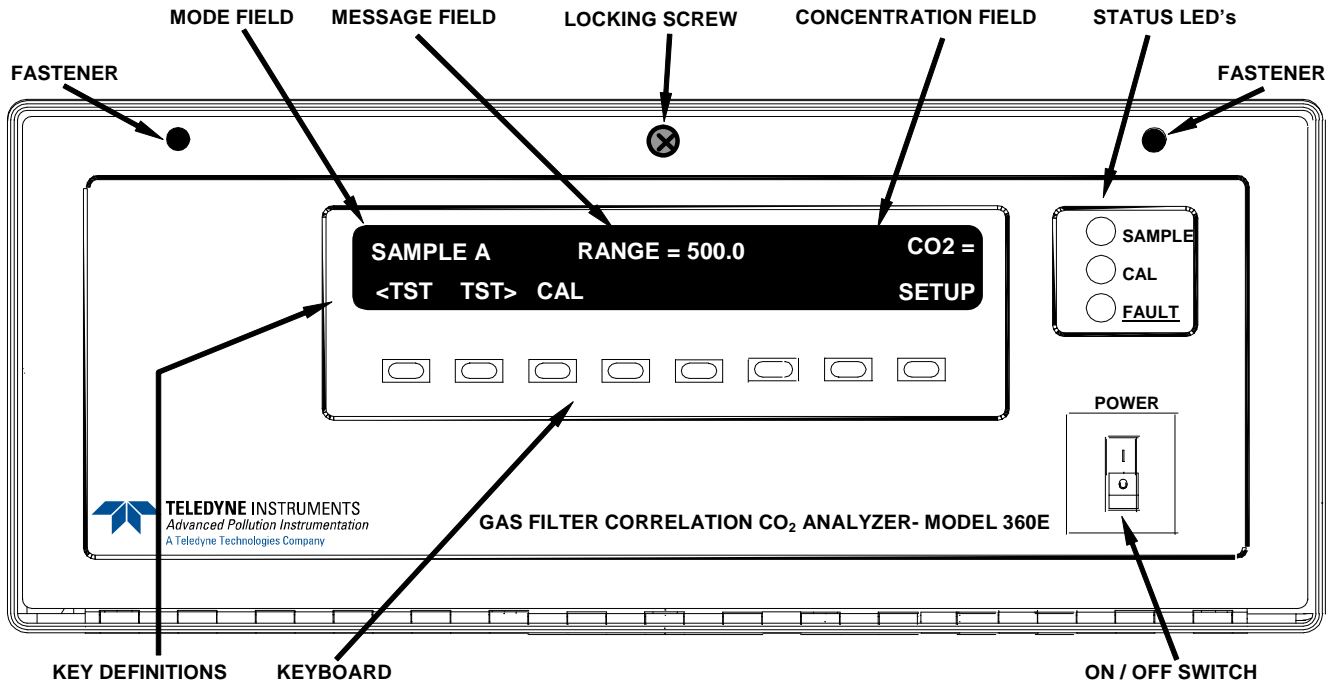

Figure 3-1: Front Panel Layout

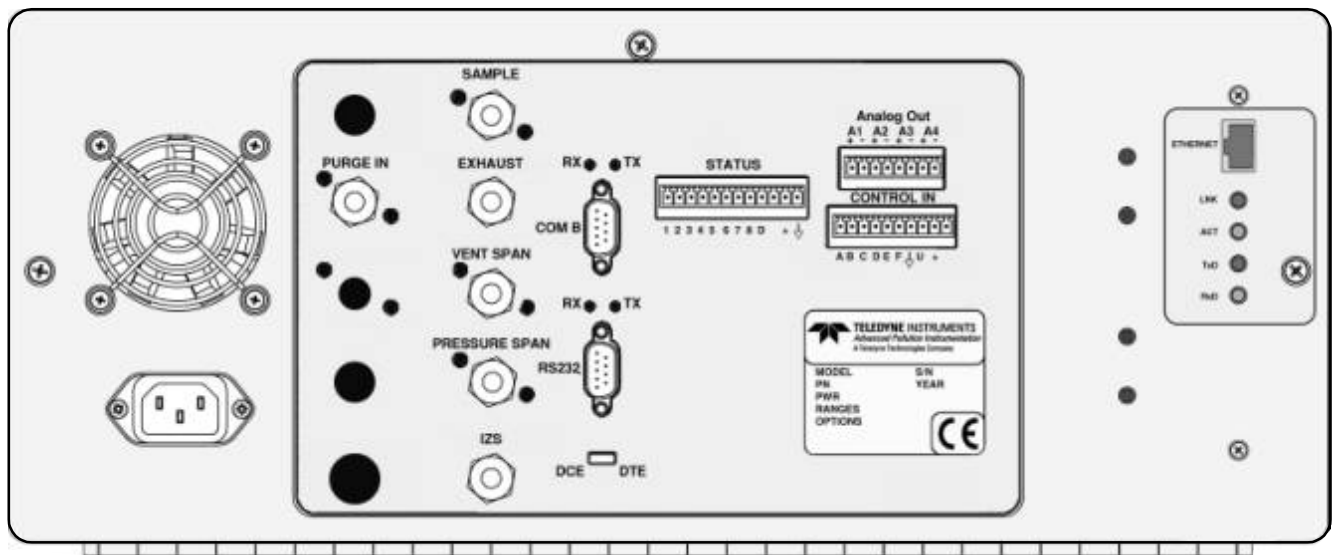

Figure 3-2: Rear Panel Layout

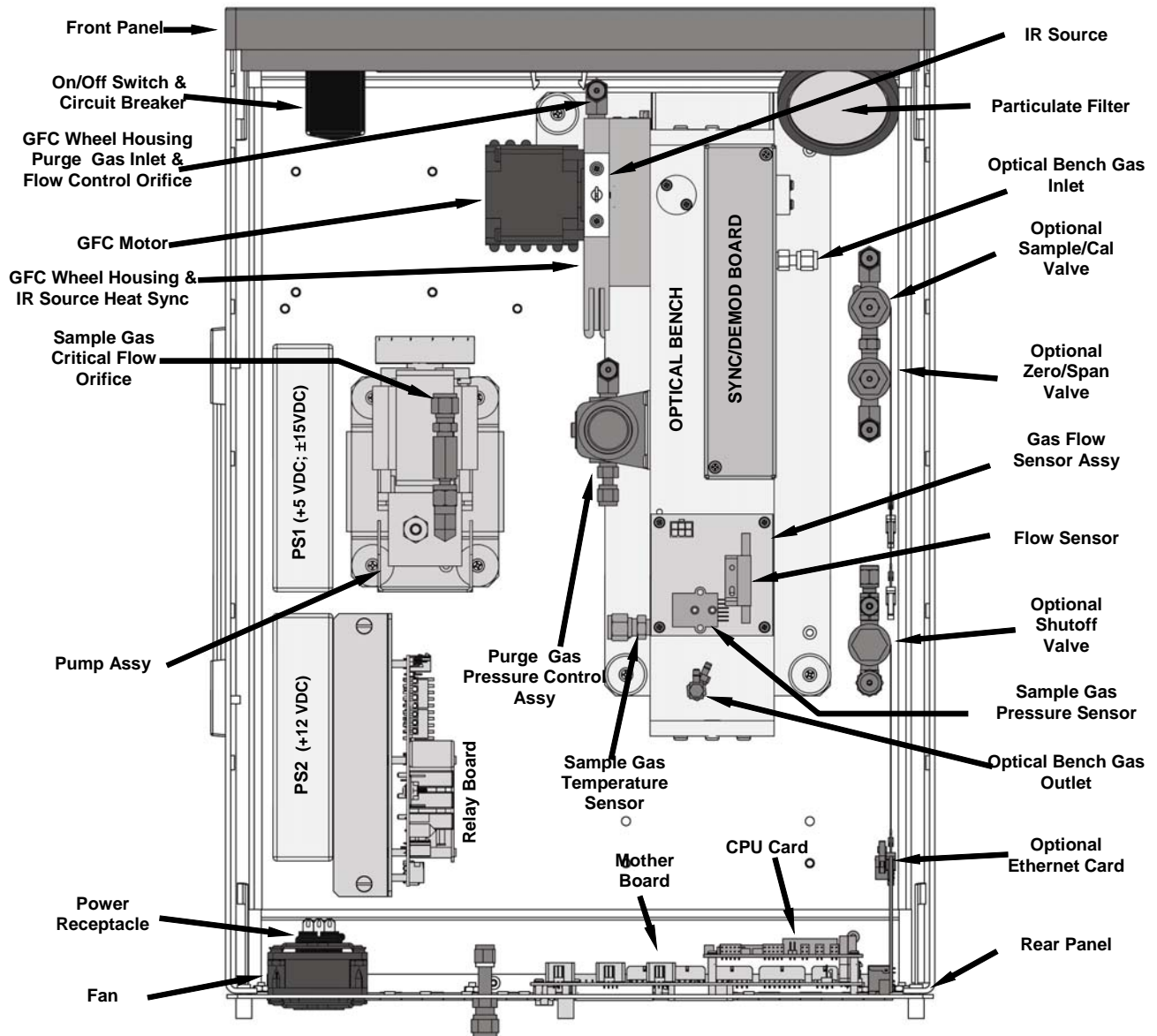

Figure 3-3: Assembly Layout

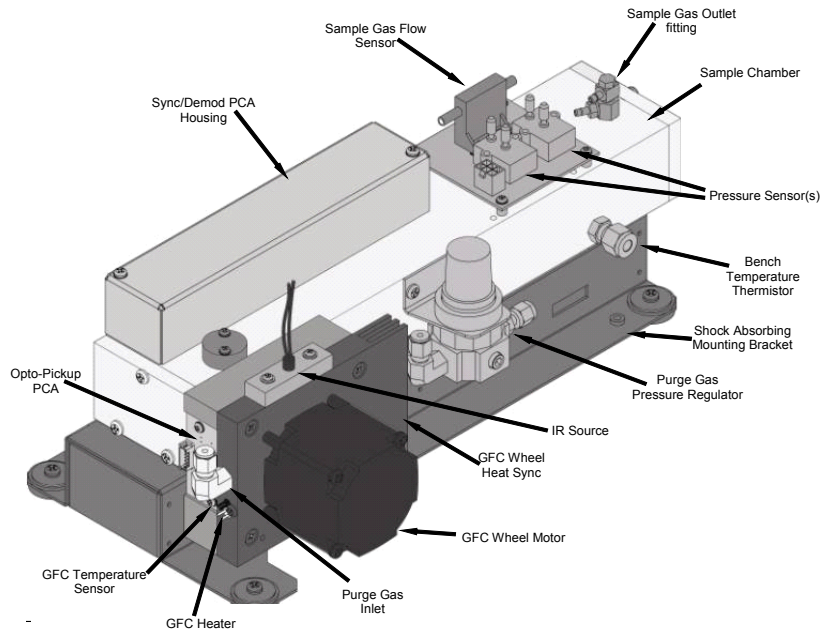

Figure 3-4: Optical Bench Layout

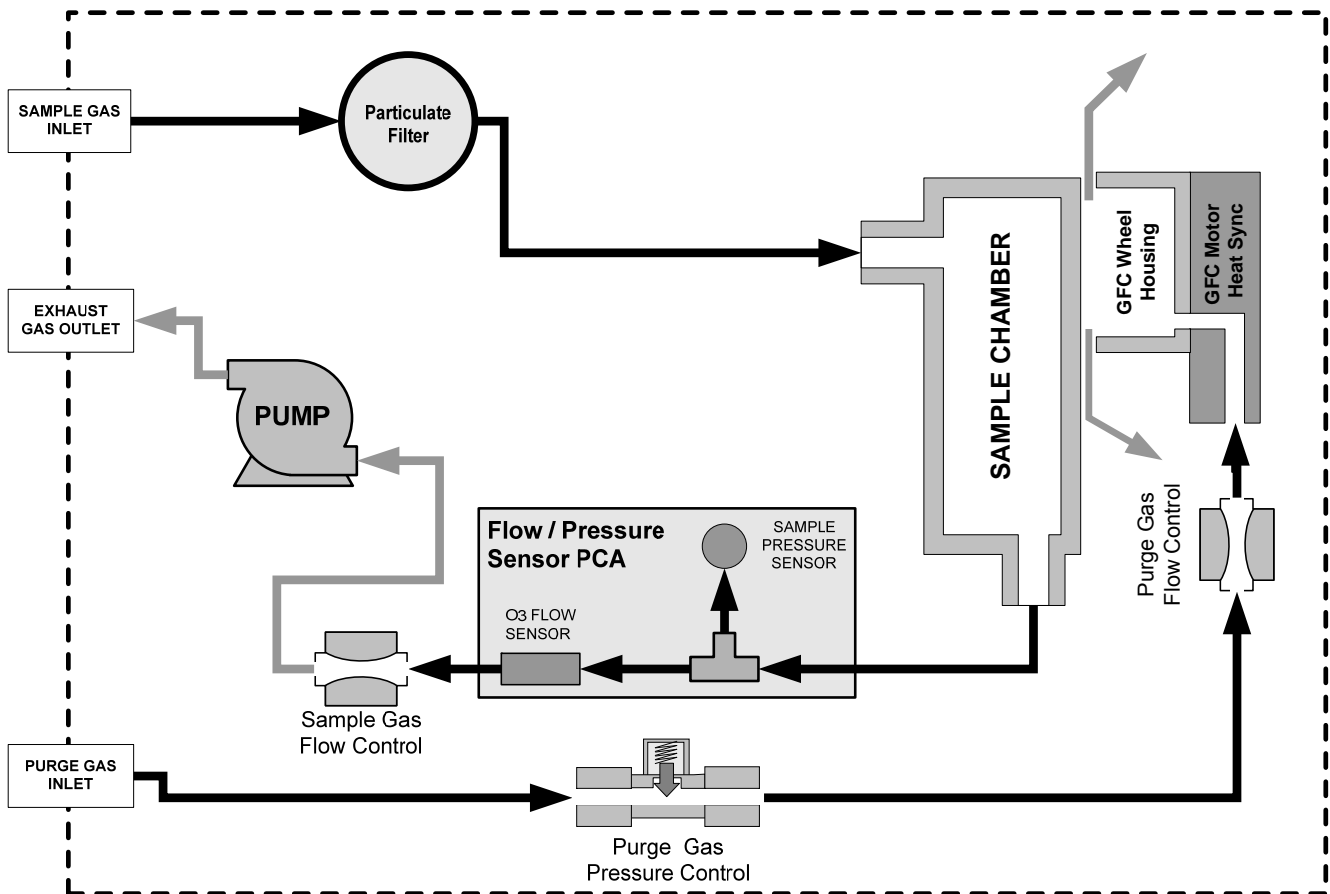



Figure 3-5: M360E Internal Gas Flow

3.1.2. Electrical Connections

3.1.2.1. Power Connection

Attach the power cord to the analyzer and plug it into a power outlet capable of carrying at least 10 A current at your AC voltage and that it is equipped with a functioning earth ground.

	<p style="text-align: center;">CAUTION</p> <p>Check the voltage and frequency label on the rear panel of the instrument (See Figure 3-2 for compatibility with the local power before plugging the M360E into line power.</p> <p style="text-align: center;">Do not plug in the power cord if the voltage or frequency is incorrect.</p>
---	---

	<p style="text-align: center;">CAUTION</p> <p>Power connection must have functioning ground connection.</p> <p style="text-align: center;">Do not defeat the ground wire on power plug.</p> <p style="text-align: center;">Turn off analyzer power before disconnecting or connecting electrical subassemblies.</p> <p style="text-align: center;">Do not operate with cover off.</p>
---	--

The M360E analyzer can be configured for both 100-130 V and 210-240 V at either 50 or 60 Hz. To avoid damage to your analyzer, make sure that the AC power voltage matches the voltage indicated on the rear panel serial number label and that the frequency is between 47 and 63 Hz.

3.1.2.2. Output Connections

The M360E is equipped with several analog output channels accessible through a connector on the back panel of the instrument. The standard configuration for these outputs is mVDC. An optional current loop output is available for each.

When the instrument is in its default configuration, channels A1 and A2 output a signal that is proportional to the CO₂ concentration of the sample gas. Either can be used for connecting the analog output signal to a chart recorder or for interfacing with a data logger.

Output A3 is only used on the Model 360E if the optional O₂ sensor is installed.

Channel A4 is special. It can be set by the user (see Section 6.13.9) to output any one of the parameters accessible through the <TST TST> keys of the units sample display.

To access these signals attach a strip chart recorder and/or data-logger to the appropriate analog output connections on the rear panel of the analyzer.

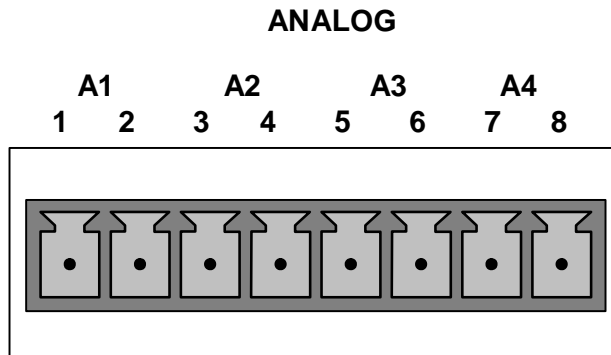

Pin-outs for the analog output connector at the rear panel of the instrument are:

Table 3-1: M360E Analog Output Pin Outs

PIN	ANALOG OUTPUT	VDC SIGNAL	MADC SIGNAL
1	A1	V Out	I Out +
2		Ground	I Out -
3	A2	V Out	I Out +
4		Ground	I Out -
7	A3 (Only used if O ₂ sensor is installed)	V Out	I Out +
8		Ground	I Out -
5	A4	V Out	I Out +
6		Ground	I Out -

- The default analog output voltage setting of the 360E CO₂ Analyzer is 0 – 5 VDC with a range of 0 – 500 ppm.
- TO change these settings, see Sections 6.13.4 and 6.8 respectively.

3.1.2.3. Connecting the Status Outputs

If you wish utilize the analyzer's status outputs to interface with a device that accepts logic-level digital inputs, such as programmable logic controllers (PLC's) they are accessed via a 12-pin connector on the analyzer's rear panel labeled STATUS.

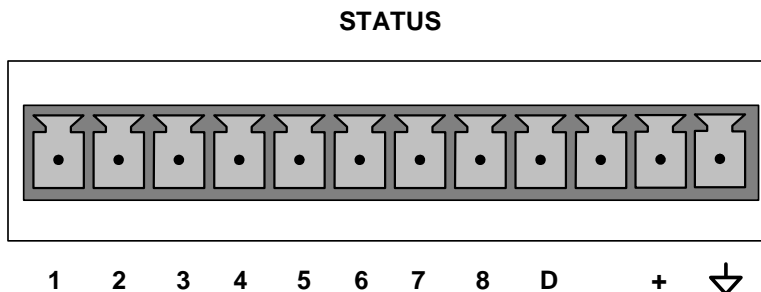

NOTE

Most PLC's have internal provisions for limiting the current the input will draw. When connecting to a unit that does not have this feature, external resistors must be used to limit the current through the individual transistor outputs to $\leq 50\text{mA}$ ($120\ \Omega$ for 5V supply).

The pin assignments for the status outputs can be found in the table below:

Table 3-2: M360E Status Output Pin Outs

OUTPUT #	STATUS DEFINITION	CONDITION
1	SYSTEM OK	On if no faults are present.
2	CONC VALID	On if CO ₂ concentration measurement is valid. If the CO ₂ concentration measurement is invalid, this bit is OFF.
3	HIGH RANGE	On if unit is in high range of DUAL or AUTO range modes.
4	ZERO CAL	On whenever the instruments ZERO point is being calibrated.
5	SPAN CAL	On whenever the instruments SPAN point is being calibrated.
6	DIAG MODE	On whenever the instrument is in DIAGNOSTIC mode.
7	ALARM1	On whenever the measured CO ₂ concentration is above the set point for ALM1
8	ALARM2	On whenever the measured CO ₂ concentration is above the set point for ALM2
D	EMITTER BUSS	The emitters of the transistors on pins 1-8 are bussed together.
+	DC POWER	+ 5 VDC
⚡	Digital Ground	The ground level from the analyzer's internal DC power supplies.

3.1.2.4. Connecting the Control Inputs

If you wish to use the analyzer to remotely activate the zero and span calibration modes, several digital control inputs are provided through a 10-pin connector labeled CONTROL IN on the analyzer's rear panel.

There are two methods for energizing the control inputs. The internal +5V available from the pin labeled "+" is the most convenient method. However, if full isolation is required, an external 5 VDC power supply should be used.

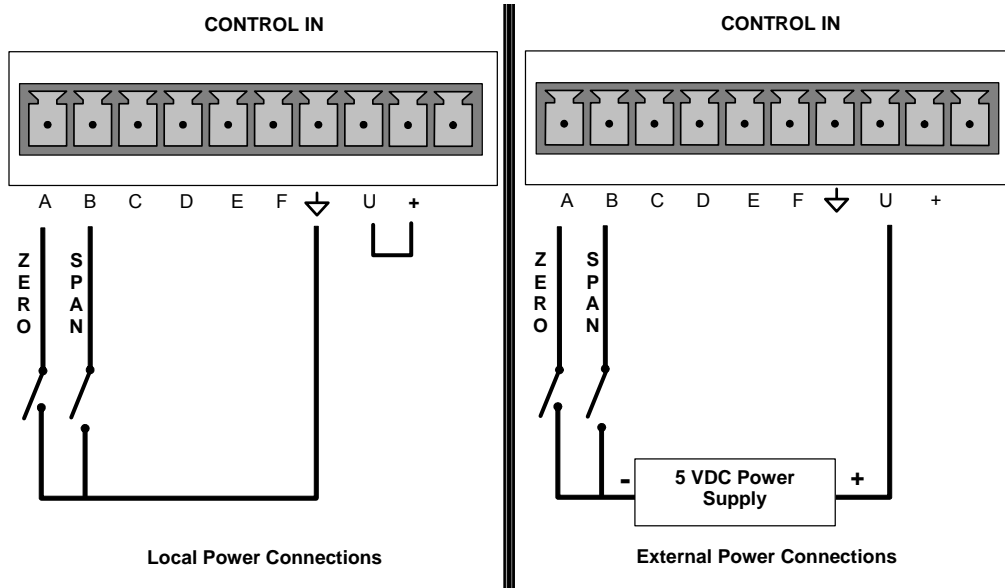

The pin assignments for the digital control inputs can be found in the table below:

Table 3-3: M360E Control Input Pin Outs

INPUT #	STATUS DEFINITION	ON CONDITION
A	REMOTE ZERO CAL	The Analyzer is placed in Zero Calibration mode. The mode field of the display will read ZERO CAL R.
B	REMOTE SPAN CAL	The Analyzer is placed in Span Calibration mode. The mode field of the display will read SPAN CAL R.
C	SPARE	
D	SPARE	
E	SPARE	
F	SPARE	
⏚	Digital Ground	May be connected to the ground of the data logger/recorder.
U	Pull-up supply for inputs	Input pin for +5 VDC required to activate pins A – F. This can be from an external source or from the "+" pin of the instruments STATUS connector.
+	Internal +5V Supply	Internal source of +5V which can be used to actuate control inputs when connected to the U pin.

3.1.2.5. Connecting the Serial Ports

If you wish to utilize either of the analyzer's two serial interface COMM ports, refer to Section 6.11 of this manual for instructions on their configuration and usage.

3.1.2.6. Connecting to a LAN or the Internet

If your unit has a Teledyne Instruments Ethernet card (Option 63), plug one end into the 7' CAT5 cable supplied with the option into the appropriate place on the back of the analyzer (see Figure 5-5 in Section 5.5.3) and the other end into any nearby Ethernet access port.

NOTE:

The M360E firmware supports dynamic IP addressing or DHCP.

If your network also supports DHCP, the analyzer will automatically configure its LAN connection appropriately,

If your network does not support DHCP, see Section 6.11.6.3 for instructions on manually configuring the LAN connection.

3.1.2.7. Connecting to a Multidrop Network

If your unit has a Teledyne Instruments RS-232 multidrop card (Option 62), see Section 6.11.7 for instructions on setting it up.

3.1.3. Pneumatic Connections:

3.1.3.1. Basic Pneumatic Connections

CAUTION

In order to prevent dust from getting into the gas flow channels of your analyzer, it was shipped with small plugs inserted into each of the pneumatic fittings on the back panel.

Make sure that all of these dust plugs are removed before attaching exhaust and supply gas lines.

Figures 3-3 and 3-4 illustrate the most common configurations for gas supply and exhaust lines to the Model 360E Analyzer. Figure 3-5 illustrates the internal gas flow of the instrument in its basic configuration.

Please refer to Figure 3-2 for pneumatic connections at the rear panel and Table 3-4 for nomenclature.

NOTE

Sample and calibration gases should only come into contact with PTFE (Teflon), FEP, glass, stainless steel or brass.

Table 3-4: Model 360E Rear Panel Pneumatic Connections

REAR PANEL LABEL	FUNCTION
SAMPLE	Connect a gas line from the source of sample gas here. Calibration gasses are also inlet here on units without zero/span/shutoff valve or IZS options installed.
EXHAUST	Connect an exhaust gas line of not more than 10 meters long here.
PRESSURE SPAN	On units with zero/span/shutoff valve options installed, connect a gas line to the source of calibrated span gas here.
VENT SPAN	Span gas vent outlet for units with zero/span/shutoff valve options installed. Connect an exhaust gas line of not more than 10 meters long here.
IZS	Internal zero air scrubber. On units with zero/span/shutoff valve options installed but NO internal zero air scrubber, attach a gas line to the source of zero air here.
PURGE IN	This inlet supplies purge air to the GFC wheel housing (see Section 10.2.3) Connect a source of dried air that has been scrubbed of CO ₂ .

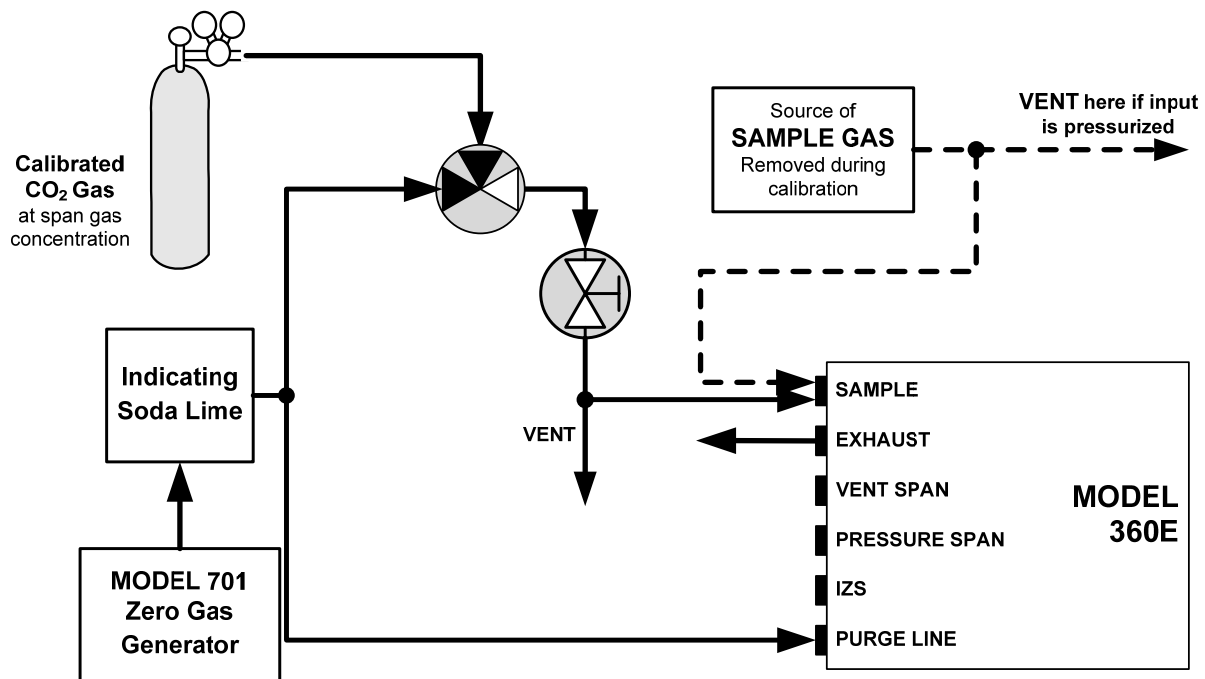

Figure 3-6: Pneumatic Connections—Basic Configuration—Using Bottled Span Gas

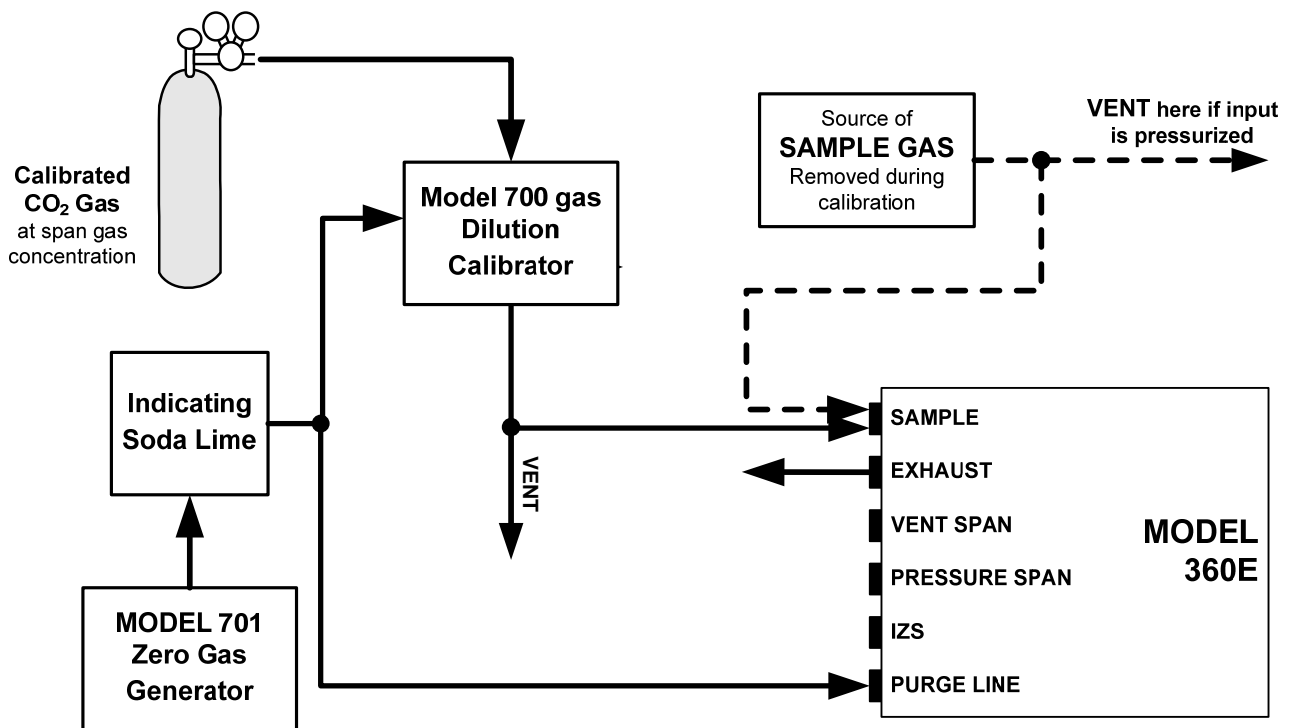

Figure 3-7: Pneumatic Connections—Basic Configuration—Using Gas Dilution Calibrator

1. Attach a sample inlet line to the sample inlet port. The SAMPLE input line should not be more than 2 meters long.

NOTE

Ideally, the pressure of the sample gas should be at ambient pressure (0 psig).
Maximum pressure of sample gas should not exceed 1.5 in-Hg over ambient.

In applications where the sample gas is received from a pressurized manifold, a vent must be placed as shown to equalize the sample gas with ambient atmospheric pressure before it enters the analyzer.

This vent line must be:

- At least 0.2m long
- No more than 2m long and vented outside the shelter or immediate area surrounding the instrument.

2. Attach sources of zero air and span gas (see Figures 3-3 through 3-8 inclusive).
 - Span Gas is a gas specifically mixed to match the chemical composition of the type of gas being measured at near full scale of the desired measurement range.

In the case of CO₂ measurements made with the Teledyne Instruments Model 360E Analyzer it is recommended that you use a gas calibrated to have a CO₂ content equaling 80% of the range of compositions being measured.

EXAMPLE: If the application is to measure between 0 ppm and 500 ppm, an appropriate Span Gas would be 400 ppm. If the application is to measure between 0 ppm and 100 ppm, an appropriate Span Gas would be 80 ppm.

- Span Gas can be purchased in pressurized canisters or created using Dynamic Dilution Calibrator such as the Teledyne Instruments Model 700 and a source of dried air scrubbed of CO₂ such as a Teledyne Instruments Model 701 Zero Air Generator in combination with a canister of indicating soda lime (such as Teledyne Instruments P/N 037600000).
- Zero Air is similar in chemical composition to the Earth's atmosphere but scrubbed of all components that might affect the analyzer's readings.

In the case of CO₂ measurements this means less than 0.1 ppm of CO₂ and Water Vapor (when dew point <-15°C). Zero Air can be purchased in pressurized canisters or created using a Teledyne Instruments Model 701 Zero Air Generator in combination with a canister of indicating soda lime (such as Teledyne Instruments P/N 037600000).

3. Attach an exhaust line to the exhaust outlet port.

- The exhaust from the pump and vent lines should be vented to atmospheric pressure using maximum of 10 meters of ¼" PTEF tubing.



CAUTION

Venting should be outside the shelter or immediate area surrounding the instrument.

4. Attach a source of dried air scrubbed of CO₂ to the purge inlet port.

NOTE

The minimum gas pressure of the source of purge air should be 7.5 psig.

If the source of the purge air is shared by a Teledyne Instruments M700 (as shown in figure 3-7) the minimum gas pressure should be 25 psig and should not exceed 35 psig.

5. Once the appropriate pneumatic connections have been made, check all pneumatic fittings for leaks using a procedure similar to that defined in Section 9.3.3.

3.1.3.2. Connections with Internal Valve Options Installed

Figures 3-8 through 3-11 show the proper pneumatic connections for M360E's with various optional internal valve sets installed.

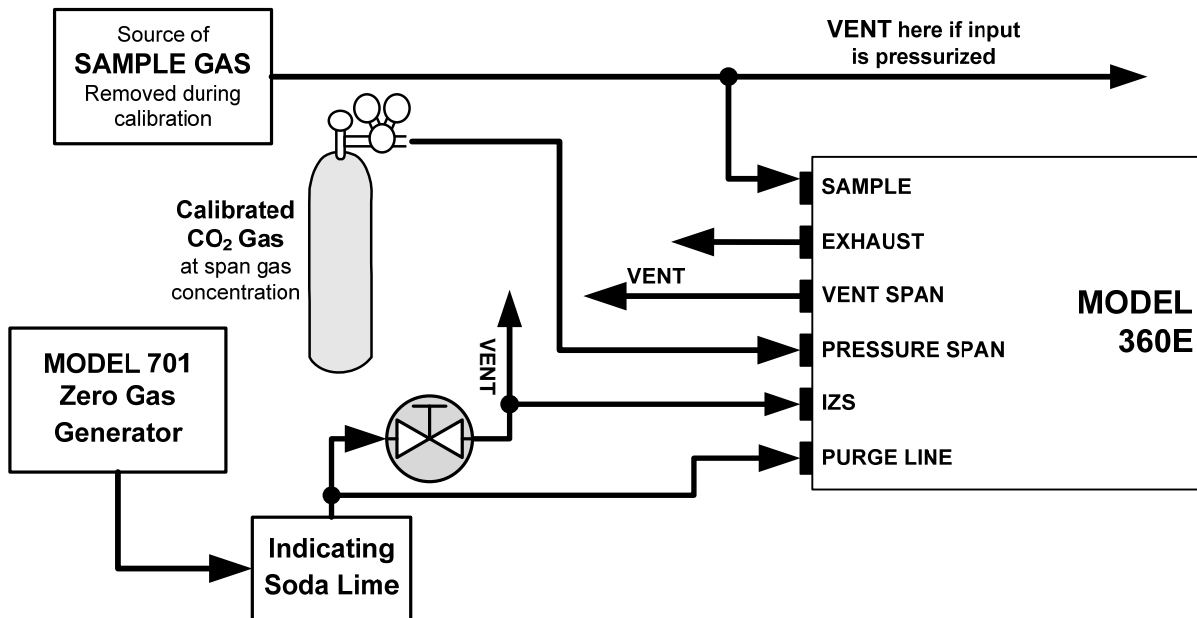

Figure 3-8: Pneumatic Connections—M360E with Zero/Span/Shutoff Valves (OPT 50)

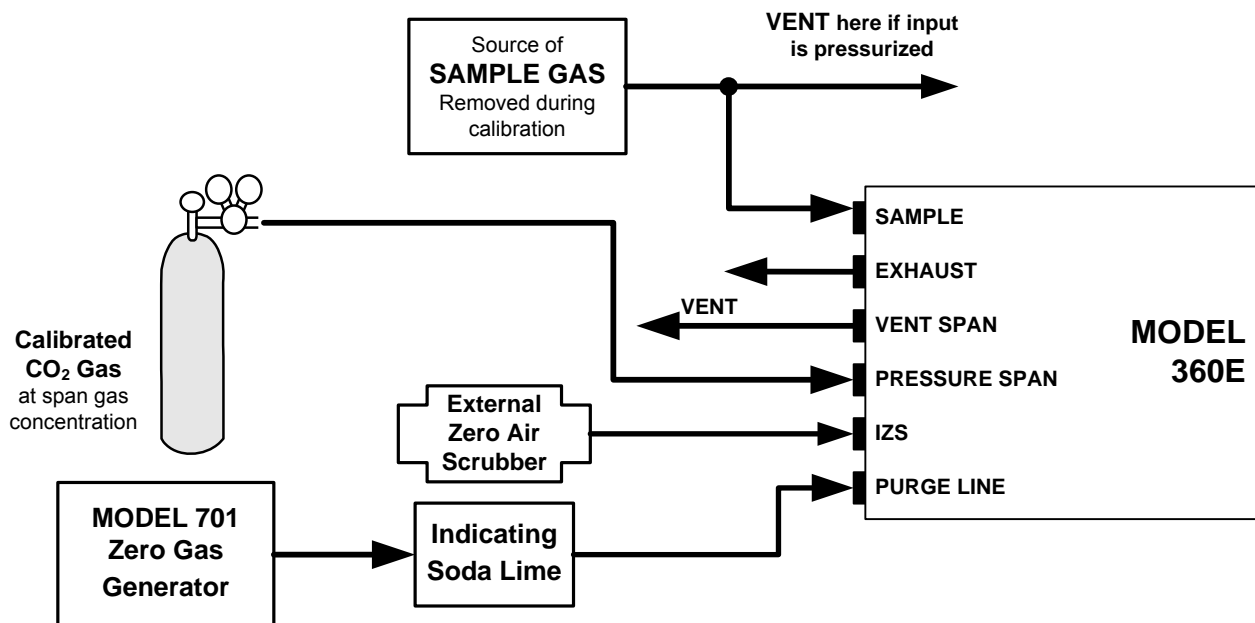

Figure 3-9: Pneumatic Connections—M360E with Zero/Span/Shutoff Valves and External Zero Air Scrubber (OPT 51)

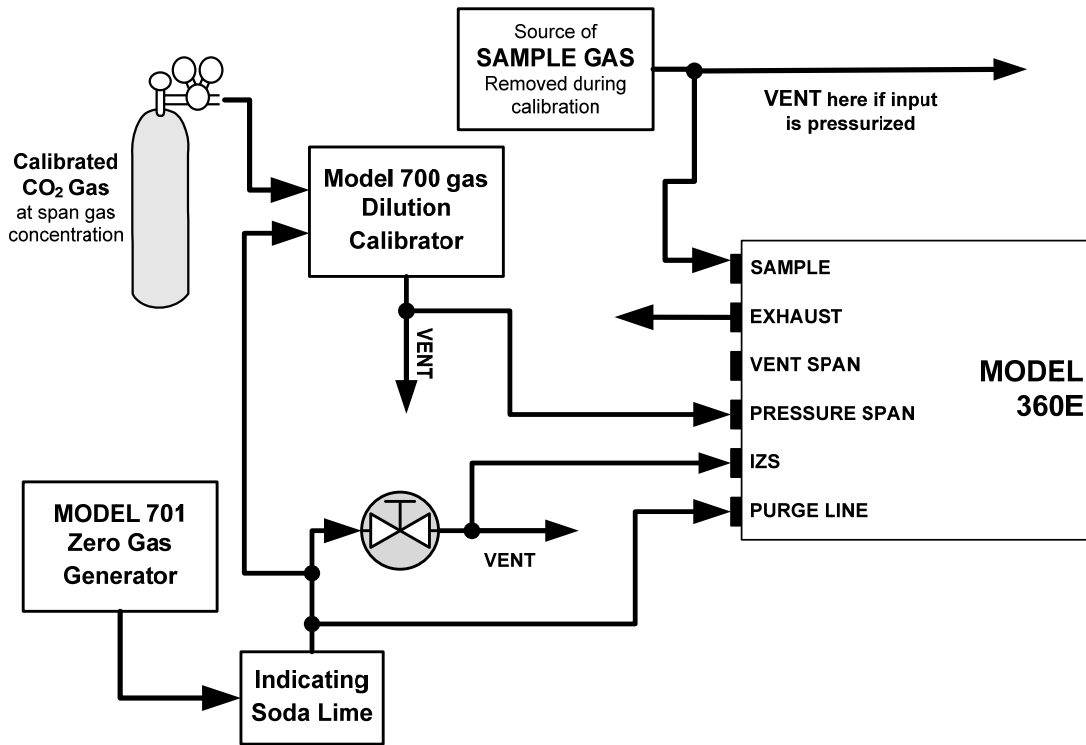

Figure 3-10: Pneumatic Connections—M360E with Zero/Span Valves (OPT 52)

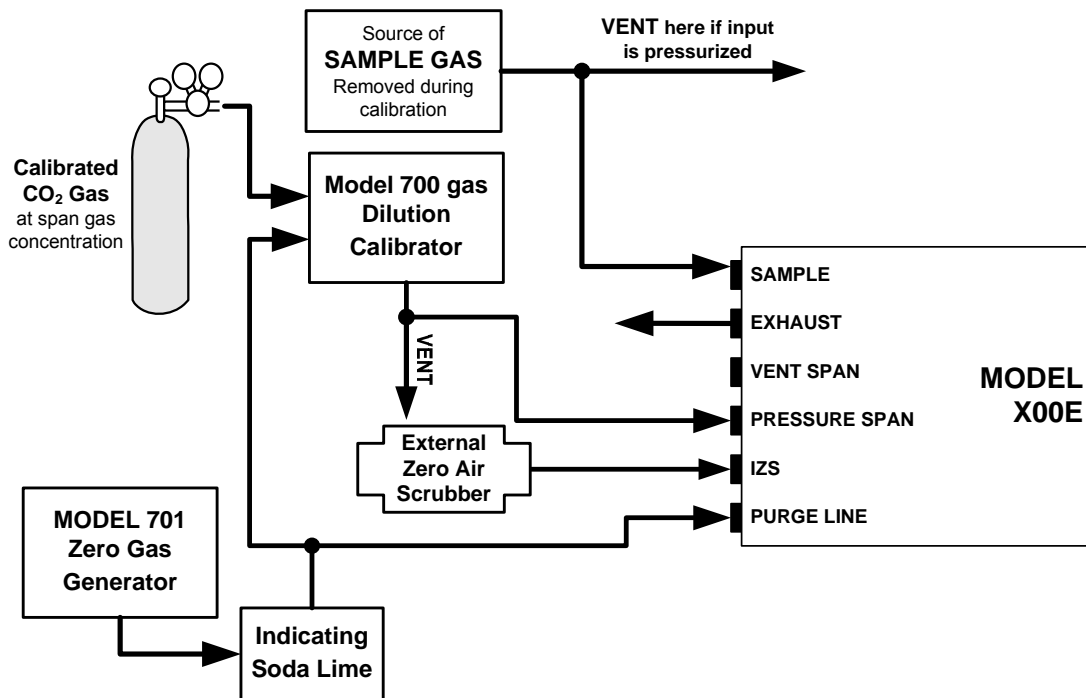

Figure 3-11: Pneumatic Connections—M360E with Zero/Span Valves with External Zero air Scrubber (OPT 53)

3.1.3.3. Pneumatic Connections to M360E in Multipoint Calibration Applications

Some applications may require multipoint calibration checks where span gas of several different concentrations is needed. We recommend using high-concentration, certified, calibration gas supplied to the analyzer through a Gas Dilution Calibrator such as a Teledyne Instruments Model 700. This type of calibrator precisely mixes Span Gas and Zero Air to produce any concentration level between 0 ppm and the concentration of the calibrated gas.

Figure 3-12 depicts the pneumatic set up in this sort of application of a Model 360E CO₂ Analyzer with zero/span/shutoff valve option 50 installed (a common configuration for this type of application).

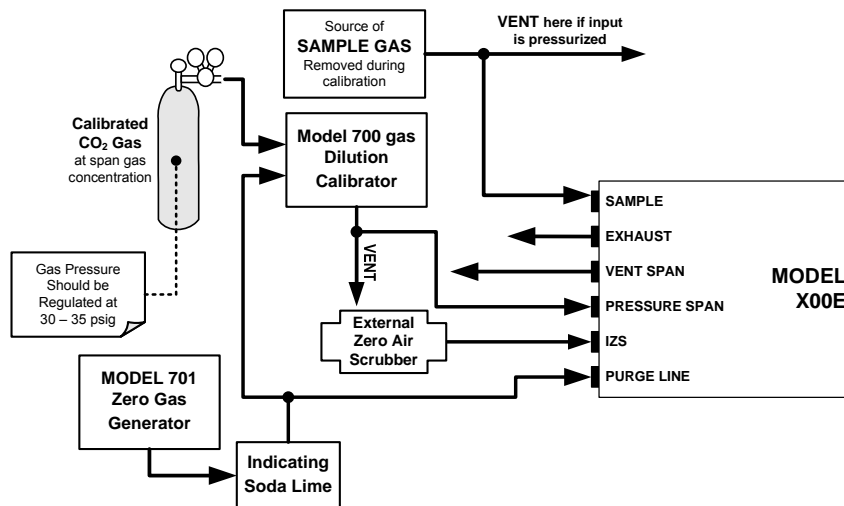

Figure 3-12: Example of Pneumatic Set up for Multipoint Calibration of M360

3.1.4. Setting the internal Purge Air Pressure.

In order to maintain proper purge air flow through the GFC wheel housing a manually adjustable pressure regulator is provided (see Figures 3-3 and 3-5). This regulator includes two output ports. One is used to supply purge air to the GFC wheel. The other may be used to attach a pressure gauge.

To adjust the internal purge air pressure of the M360E:

1. Turn off the instrument.
2. Remove the source of zero air attached to the purge line inlet port at the back of the analyzer.
3. Remove the analyzer's top cover.
4. Remove the cap from the second, unused, output port on the pressure regulator.
5. Attach a pressure gauge capable of measuring in the 5-10 psig range with 0.5 psig resolution to the port.
6. Turn the instrument on.
7. Make sure the zero air supply to the analyzer's purge line inlet is supplying gas at a stable pressure above 7.5 psig.
8. Adjust the M360E's pressure regulator until the attached gauge reads 7.5 psig.
9. Turn off the instrument.
10. Remove the source of zero air attached to the purge line inlet port at the back of the analyzer.
11. Remove the pressure gauge and reattach the end cap removed in step 4 above.
12. Replace the analyzer's top cover.

3.2. Initial Operation

If you are unfamiliar with the M360E theory of operation, we recommend that you read Chapter 10. For information on navigating the analyzer’s software menus, see the menu trees described in Appendix A.1.

NOTE

The analyzer’s cover must be installed to ensure that the temperatures of the GFC wheel and absorption cell assemblies are properly controlled.

3.2.1. Startup

After electrical and pneumatic connections are made, turn on the instrument. The pump, exhaust fan and PMT cooler fan should start immediately. The display should immediately display a single, horizontal dash in the upper left corner of the display. This will last approximately 30 seconds while the CPU loads the operating system.

Once the CPU has completed this activity it will begin loading the analyzer firmware and configuration data. During this process, string of messages will appear on the analyzer’s front panel display:

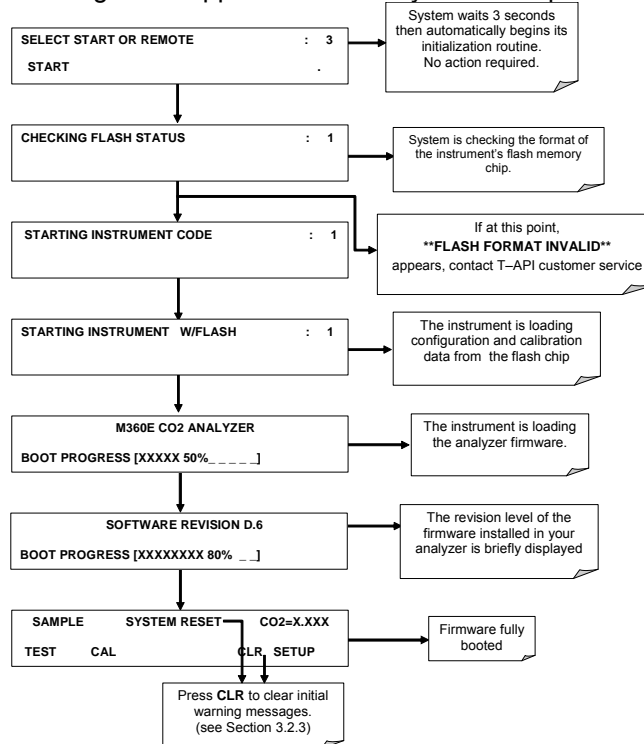

The analyzer should automatically switch to **SAMPLE** mode after completing the boot-up sequence and start monitoring CO₂ gas.

3.2.2. Warm Up

The M360E requires about 30 minutes warm-up time before reliable CO₂ measurements can be taken. During that time, various portions of the instrument's front panel will behave as follows. See Figure 3-1 for locations.

Table 3-5: Front Panel Display During System Warm-Up

Name	Color	Behavior	Significance
Concentration Field	N/A	Displays current, compensated CO ₂ Concentration	N/A
Mode Field	N/A	Displays blinking "SAMPLE"	Instrument is in sample mode but is still in the process of warming up.
STATUS LED's			
Sample	Green	On	Unit is operating in sample mode; front panel display is being updated. Flashes On/Off when adaptive filter is active
Cal	Yellow	Off	The instrument's calibration is not enabled.
Fault	Red	Blinking	The analyzer is warming up and hence out of specification for a fault-free reading. Various warning messages will appear.

3.2.3. Warning Messages

Because internal temperatures and other conditions may be outside specified limits during the analyzer's warm-up period, the software will suppress most warning conditions for 30 minutes after power up. If warning messages persist after the 30 minutes warm up period is over, investigate their cause using the troubleshooting guidelines in Chapter 11 of this manual.

To view and clear warning messages, press:

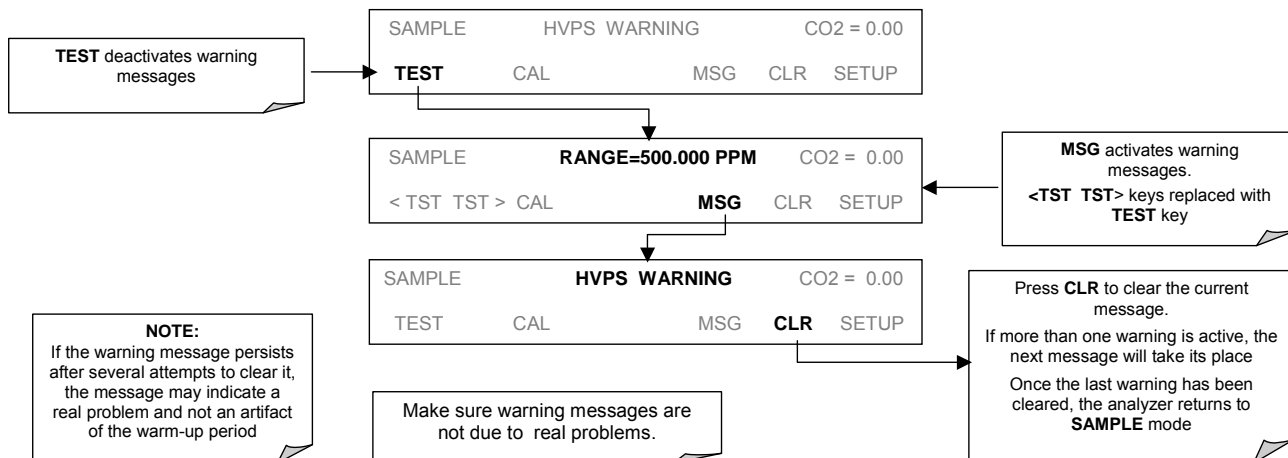

Table 3-6 lists brief descriptions of the warning messages that may occur during start up.

Table 3-6: Possible Warning Messages at Start-Up

MESSAGE	MEANING
ANALOG CAL WARNING	The instrument's A/D circuitry or one of its analog outputs is not calibrated.
BENCH TEMP WARNING	The Temperature of the optical bench is outside the specified limits.
BOX TEMP WARNING	Remote span calibration failed while the dynamic span feature was set to turned on
CANNOT DYN SPAN	Remote zero calibration failed while the dynamic zero feature was set to turned on
CANNOT DYN ZERO	Configuration was reset to factory defaults or was erased.
CONC ALRM1 WARNING	Concentration alarm 1 is enabled and the measured CO ₂ level is ≥ the set point.
CONC ALRM2 WARNING	Concentration alarm 2 is enabled and the measured CO ₂ level is ≥ the set point.
CONFIG INITIALIZED	Configuration storage was reset to factory configuration or erased.
DATA INITIALIZED	iDAS data storage was erased.
O2 CELL TEMP WARN	O ₂ sensor cell temperature outside of warning limits.
PHOTO TEMP WARNING	The temperature of the IR photometer is outside the specified limits.
REAR BOARD NOT DET	The CPU is unable to communicate with the motherboard.
RELAY BOARD WARN	The firmware is unable to communicate with the relay board.
SAMPLE FLOW WARN	The flow rate of the sample gas is outside the specified limits.
SAMPLE PRESS WARN	Sample gas pressure outside of operational parameters.
SAMPLE TEMP WARN	The temperature of the sample gas is outside the specified limits.
SOURCE WARNING	The IR source may be faulty.
SYSTEM RESET	The computer was rebooted.
WHEEL TEMP WARNING	The Gas Filter Correlation wheel temperature is outside the specified limits.

3.2.4. Functional Check

1. After the analyzer's components has warmed up for at least 30 minutes, verify that the software properly supports any hardware options that were installed.
2. Check to make sure that the analyzer is functioning within allowable operating parameters. Appendix C includes a list of test functions viewable from the analyzer's front panel as well as their expected values. These functions are also useful tools for diagnosing performance problems with your analyzer (Section 11.1.2). The enclosed Final Test and Validation Data sheet (part number 04307) lists these values before the instrument left the factory.

To view the current values of these parameters press the following key sequence on the analyzer's front panel. Remember until the unit has completed its warm up these parameters may not have stabilized.

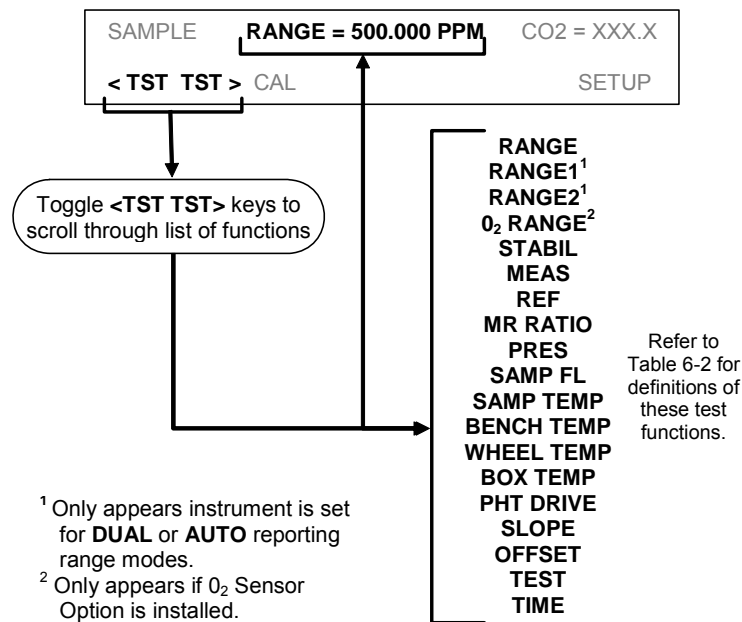

3. If your analyzer has an Ethernet card (Option 63) installed and your network is running a dynamic host configuration protocol (DHCP) software package, the Ethernet option will automatically configure its interface with your LAN. However, it is a good idea to check these settings to make sure that the DHCP has successfully downloaded the appropriate network settings from your network server (See Section 6.11.6.2).

If your network is not running DHCP, you will have to configure the analyzer's interface manually (See Section 6.11.6.3).

3.3. Initial Calibration Procedure

The next task is to calibrate the analyzer.

To perform the following calibration you must have sources for zero air and span gas available for input into the sample port on the back of the analyzer. See Section 3.1.3 for instructions for connecting these gas sources.

While it is possible to perform this procedure with any range setting we recommend that you perform this initial checkout using the 500 ppm range.

	<p>NOTE</p> <p>The following procedure assumes that the instrument does not have any of the available Zero/Span Valve Options installed.</p> <p>See Section 7.4 for instructions for calibrating instruments possessing Z/S valve options.</p>
---	---

1. Set the Analog Output Range of the M360E

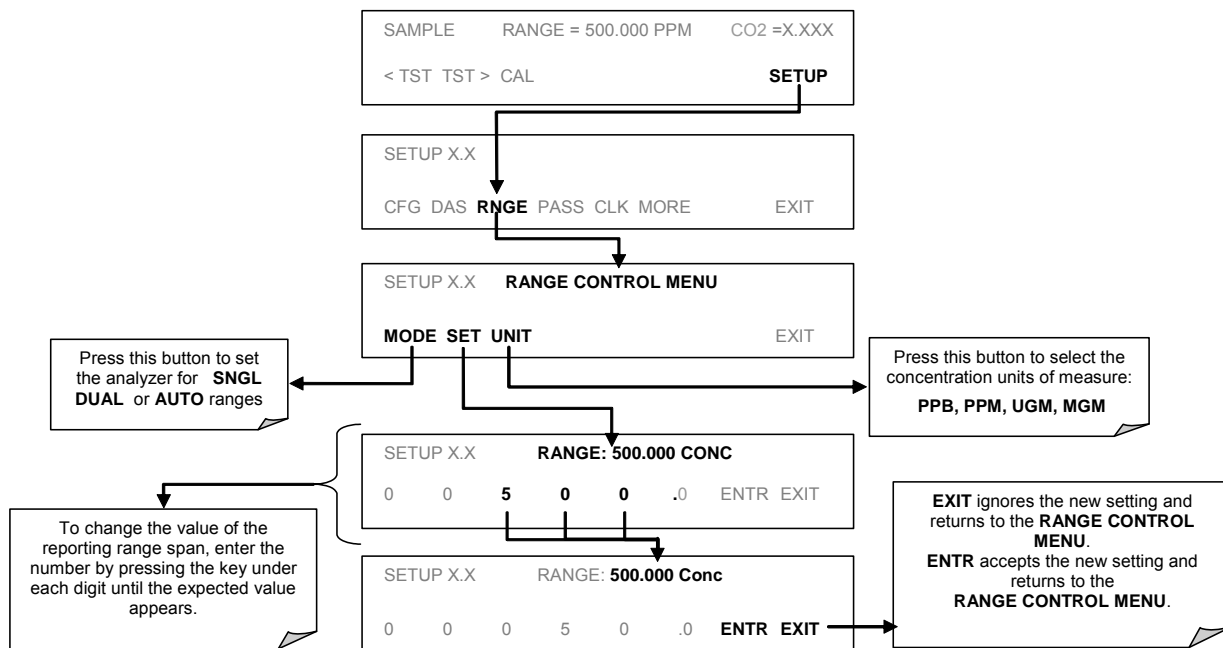

2. Set the expected CO₂ span gas concentration

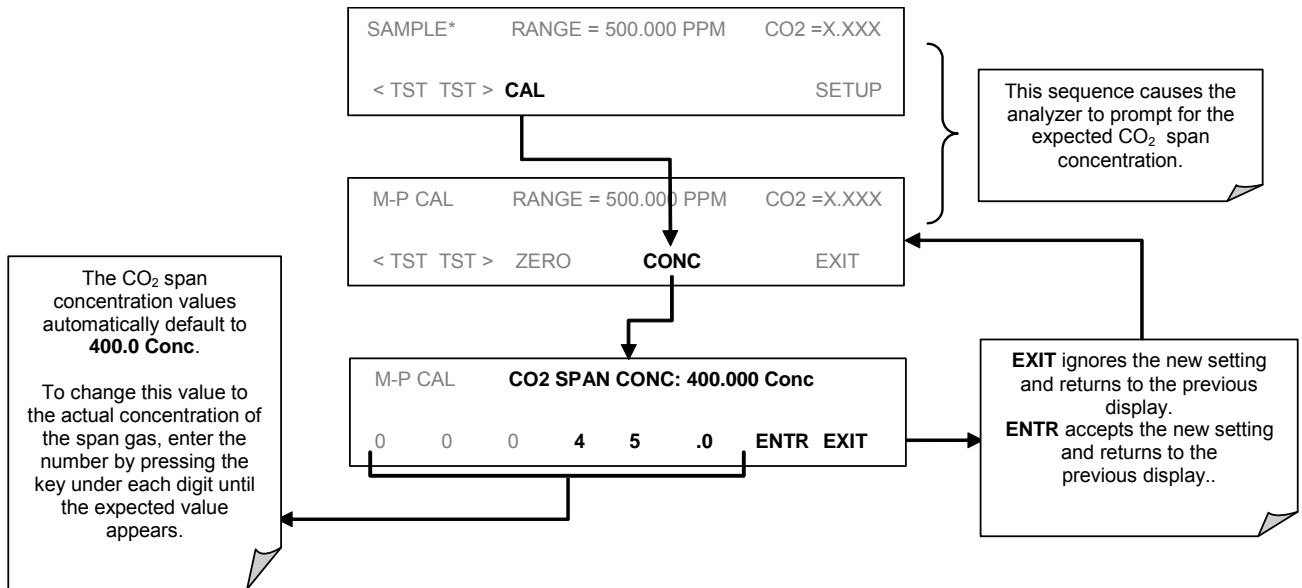

NOTE

For this Initial Calibration it is important to independently verify the precise CO₂ Concentration Value of the SPAN gas.

If the source of the Span Gas is from a Calibrated Bottle, use the exact concentration value printed on the bottle.

3. Perform the Zero/Span Calibration Procedure

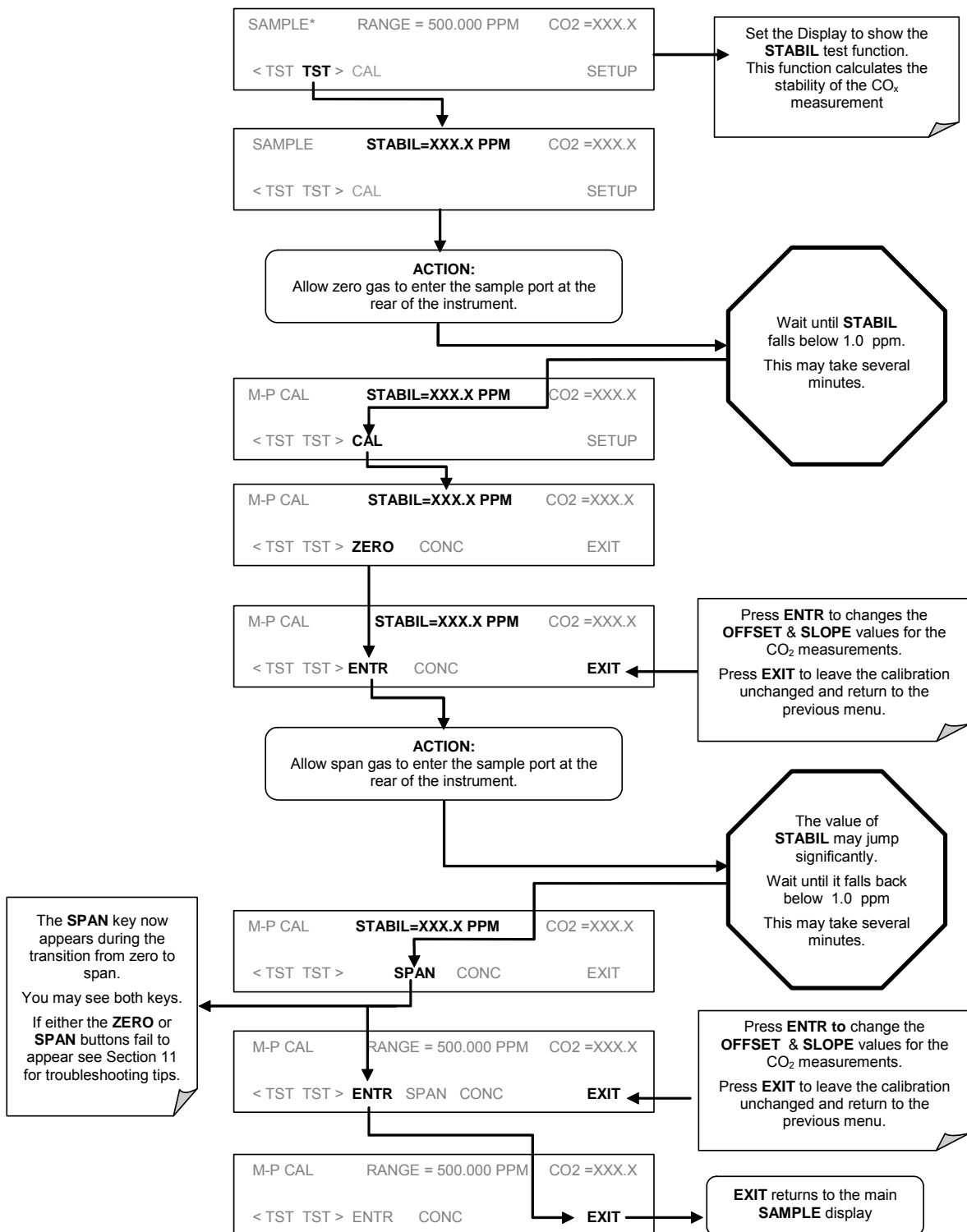

3.3.1. Initial O₂ Sensor Calibration Procedure

If your instrument has an O₂ sensor option installed that should be calibrated as well.

3.3.1.1. O₂ Calibration Setup

The pneumatic connections for calibrating are as follows:

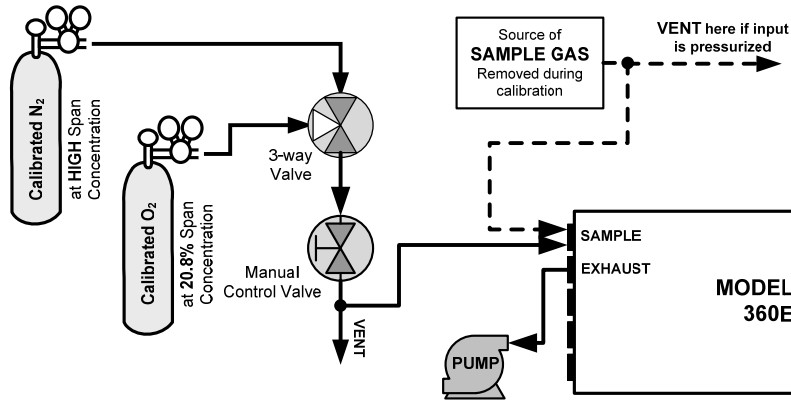

Figure 3-13: O₂ Sensor Calibration Set Up

O₂ SENSOR ZERO GAS: Teledyne Instruments' recommends using pure N₂ when calibration the zero point of your O₂ sensor option.

O₂ SENSOR SPAN GAS: Teledyne Instruments' recommends using 21% O₂ in N₂ when calibration the span point of your O₂ sensor option.

3.3.1.2. O₂ Calibration Method

STEP 1 – SET O₂ SPAN GAS CONCENTRATION :

Set the expected O₂ span gas concentration.

This should be equal to the percent concentration of the O₂ span gas of the selected reporting range (default factory setting = 20.8%; the approximate O₂ content of ambient air).

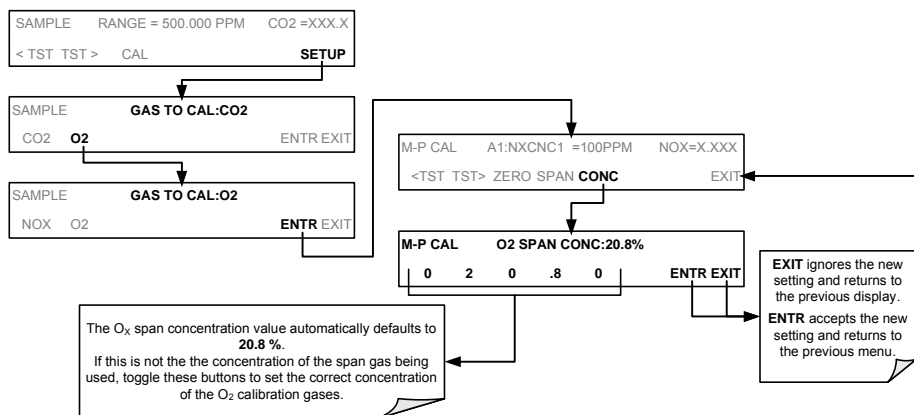

STEP 2 – ACTIVATE O₂ SENSOR STABILITY FUNCTION

To change the stability test function from NO_x concentration to the O₂ sensor output, press:

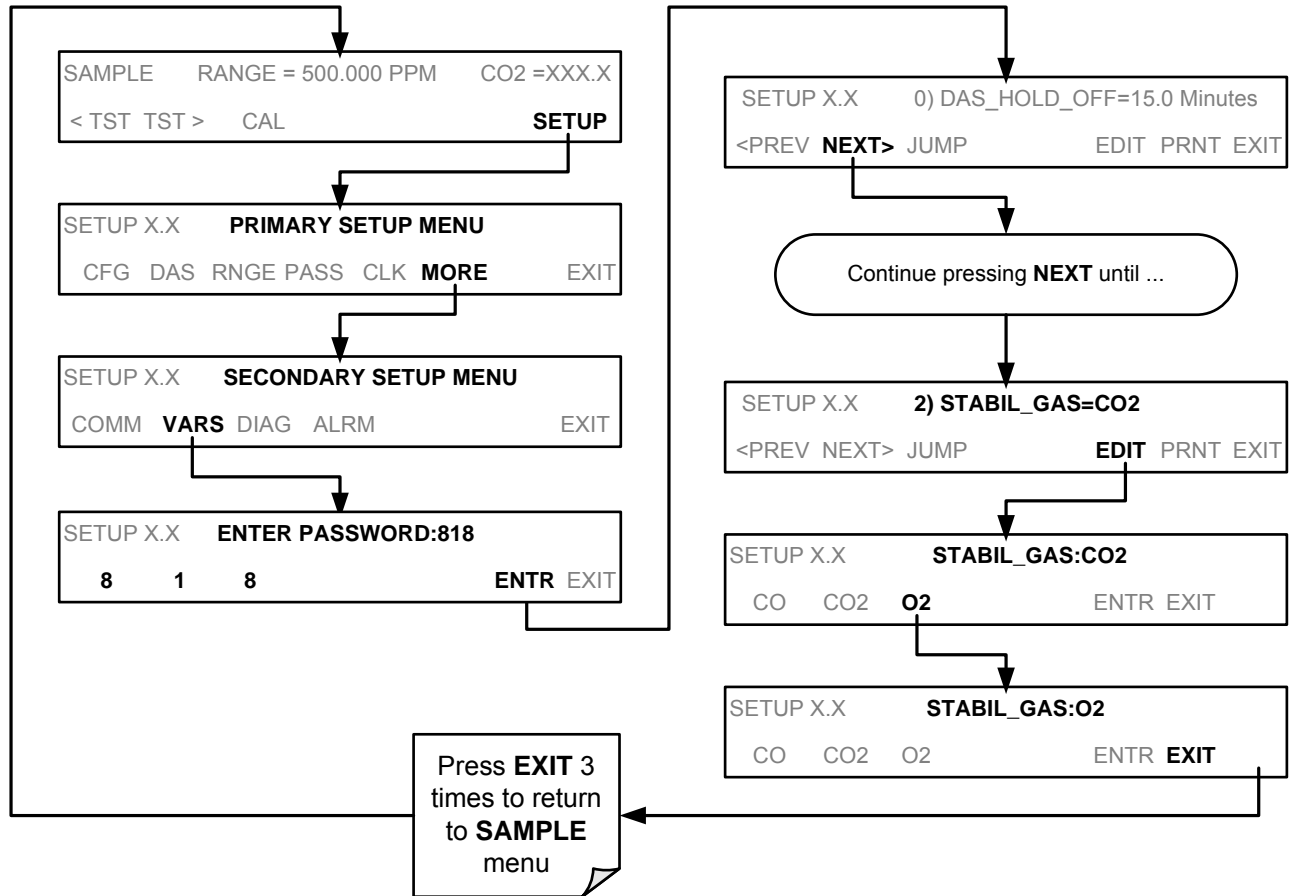

NOTE

Use the same procedure to reset the STB test function to CO₂ when the O₂ calibration procedure is complete.

STEP 4 – O₂ Zero/Span Calibration:

To perform the zero/span calibration procedure:

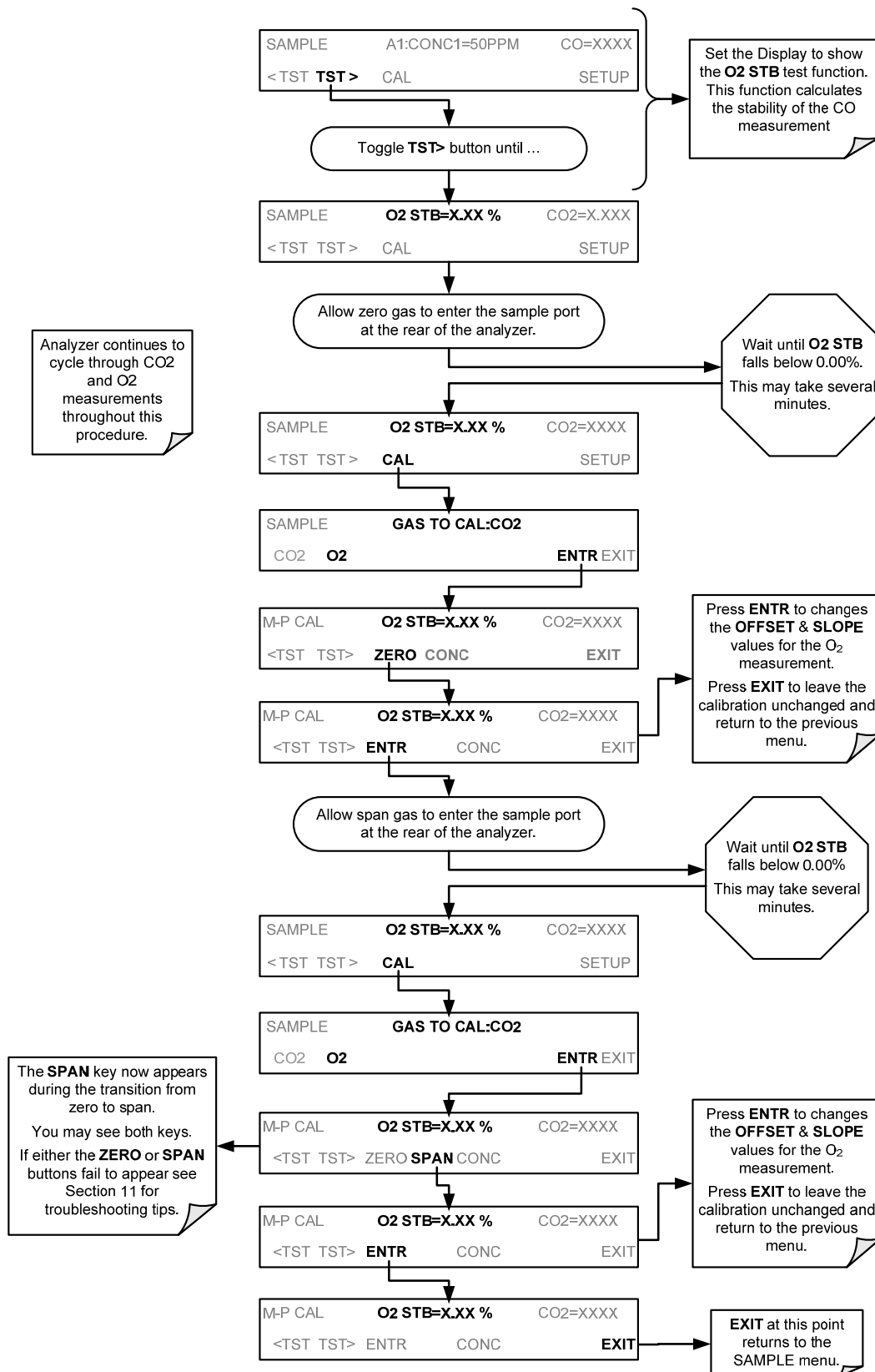

The Model 360E Analyzer is now ready for operation

NOTE

Once you have completed the above set-up procedures, please fill out the Quality Questionnaire that was shipped with your unit and return it to Teledyne Instruments.

This information is vital to our efforts in continuously improving our service and our products.

THANK YOU.

User Notes

4. FREQUENTLY ASKED QUESTIONS

4.1. FAQ's

The following is a list from the Teledyne Instruments' Customer Service Department of the most commonly asked questions relating to the Model CO₂ Analyzer.

Q: How do I get the instrument to zero / Why is the zero key not displayed?

A: See Section 11.3.4 Inability to zero.

Q: How do I get the instrument to span / Why is the span key not displayed?

A: See Section 11.3.3 Inability to span.

Q: Why does the **ENTR** key sometimes disappear on the Front Panel Display?

A: During certain types of adjustments or configuration operations, the **ENTR** key will disappear if you select a setting that is nonsensical (such as trying to set the 24-hour clock to 25:00:00) or out of the allowable range for that parameter (such as selecting an iDAS Holdoff period of more than 20 minutes).

Once you adjust the setting in question to an allowable value, the **ENTR** key will re-appear.

Q: Is there an optional midpoint calibration?

A: There is an optional mid point linearity adjustment; however, midpoint adjustment is applicable only to applications where CO₂ measurements are expected above 100 ppm. Call Teledyne Instruments' Service Department for more information on this topic.

Q: How do I make the display and data logger analog input agree?

A: This most commonly occurs when an independent metering device is used besides the data logger/recorded to determine gas concentration levels while calibrating the analyzer. These disagreements result from the analyzer, the metering device and the data logger having slightly different ground levels.

Both the electronic scale and offset of the analog outputs can be adjusted (see Section 6.13.4.3). Alternately, use the data logger itself as the metering device during calibrations procedures.

Q: How do I perform a leak check?

A: See Section 9.3.3.

Q: How do I measure the sample flow?

A: Sample flow is measured by attaching a calibrated rotameter, wet test meter, or other flow-measuring device to the sample inlet port when the instrument is operating. The sample flow should be 800 cm³/min ±10%. See Section 9.3.4.

Q: How long does the IR source last?

A: Typical lifetime is about 2-3 years.

Q: Where is the sintered filter/sample flow control orifice?

A: These components are located inside the flow control assembly that is attached to the inlet side of the sample pump, see Figure 3-3. See Section 11.6.1 for instructions on disassembly and replacement.

Q: How do I set up a SEQUENCE to run a nightly calibration check?

A: The setup of this option is located in Section 7.6.

Q: How do I set the analog output signal range and offset?

A: Instructions for this can be found in Section 6.13.4 which describes analog I/O configuration.

Q: What is the averaging time for an M360E?

A: The default averaging time, optimized for ambient pollution monitoring, is 150 seconds for stable concentrations and 10 seconds for rapidly changing concentrations; See Section 10.5.1 for more information. However, it is adjustable over a range of 0.5 second to 200 seconds (please contact customer service for more information).

4.2. Glossary

APICOM – Name of a remote control program offered by Teledyne-API to its customers

ASSY - acronym for *Assembly*

cm³ - metric abbreviation for *cubic centimeter*. Same as the obsolete abbreviation “cc”.

Chemical formulas used in this document:

- CO₂ – carbon dioxide
- H₂O – water vapor
- O₂ - molecular oxygen
- O₃ - ozone

DAS - acronym for *data acquisition system*, the old acronym of iDAS.

DIAG - acronym for *diagnostics*, the diagnostic settings of the analyzer

DHCP: acronym for *dynamic host configuration protocol*. A protocol used by LAN or Internet servers to automatically set up the interface protocols between themselves and any other addressable device connected to the network.

DOC - *Disk On Chip*, the analyzer's central storage area for analyzer firmware, configuration settings and data. This is a solid state device without mechanically moving parts that acts as a computer hard disk drive under → DOS with disk label “C”. DOC chips come with 8 Mb in the E-series analyzer standard configuration but are available in larger sizes.

DOS - *Disk Operating System*. The E-series analyzers uses DR DOS

EEPROM - also referred to as a FLASH chip.

FLASH - flash memory is non-volatile, solid-state memory.

GFC – Acronym for *Gas Filter Correlation*.

I²C bus - a clocked, bi-directional, serial bus for communication between individual analyzer components

IC – Acronym for *Integrated Circuit*, a modern, semi-conductor circuit that can contain many basic components such as resistors, transistors, capacitors etc in a miniaturized package used in electronic assemblies.

iDAS - acronym for *internal data acquisition system*

IP – acronym for *internet protocol*

LAN - acronym for *local area network*

LED - acronym for *light emitting diode*

PCA - acronym for *printed circuit assembly*, the → PCB with electronic components, ready to use.

PCB - acronym for *printed circuit board*, the bare board without electronic components

PLC – Acronym for *programmable logic controller*, a device that is used to control instruments based on a logic level signal coming from the analyzer

PFA – Acronym for Per-Fluoro-Alkoxy, an inert polymer. One of the polymers that *du Pont* markets as *Teflon*[®] (along with FEP and PTFE).

PTFE – Acronym for Poly-Tetra-Fluoro-Ethylene, a very inert polymer material used to handle gases that may react on other surfaces. One of the polymers that *du Pont* markets as *Teflon*[®] (along with FEP and PFA).

PVC – Acronym for *Poly Vinyl Chloride*, a polymer used for downstream tubing in the M360E.

RS-232 - an electronic communications type of a serial communications port

RS-485 - an electronic communications type of a serial communications port

TCP/IP - acronym for *transfer control protocol / internet protocol*, the standard communications protocol for Ethernet devices.

VARS - acronym for *variables*, the variables settings of the analyzer

User Notes

5. OPTIONAL HARDWARE AND SOFTWARE

This includes a brief description of the hardware and software options available for the Model 360E Gas Filter Correlation Carbon Dioxide Analyzer. For assistance with ordering these options please contact the Sales department of Teledyne – Advanced Pollution Instruments at:

TOLL-FREE: 800-324-5190
FAX: 858-657-9816
TEL: 858-657-9800
E-MAIL: apisales@teledyne.com
WEB SITE: www.teledyne-api.com

5.1. Rack Mount Kits (Options 20a, 20b & 21)

OPTION NUMBER	DESCRIPTION
OPT 20A	Rack mount brackets with 26 in. chassis slides.
OPT 20B	Rack mount brackets with 24 in. chassis slides.
OPT 21	Rack mount brackets only

Each of these options permits the Analyzer to be mounted in a standard 19" x 30" RETMA rack.

5.2. Current Loop Analog Outputs (Option 41)

This option adds isolated, voltage-to-current conversion circuitry to the analyzer’s analog outputs. This option may be ordered separately for any of the analog outputs; it can be installed at the factory or added later. Call T-API sales for pricing and availability.

The current loop option can be configured for any output range between 0 and 20 mA. Information on calibrating or adjusting these outputs can be found in Section 6.13.4.4.

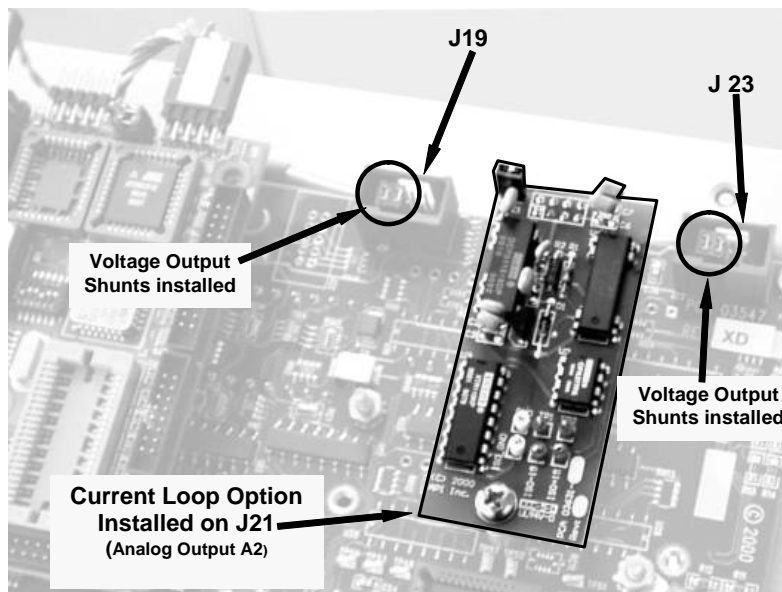

Figure 5-1: Current Loop Option Installed on the Motherboard

5.2.1. Converting Current Loop Analog Outputs to Standard Voltage Outputs.

NOTE

Servicing or handling of circuit components requires electrostatic discharge protection, i.e. ESD grounding straps, mats and containers. Failure to use ESD protection when working with electronic assemblies will void the instrument warranty.

See Chapter 12 for more information on preventing ESD damage.

To convert an output configured for current loop operation to the standard 0 to 5 VDC output operation:

4. Turn off power to the analyzer.
5. If a recording device was connected to the output being modified, disconnect it.
6. Remove the top cover
 - Remove the set screw located in the top, center of the rear panel
 - Remove the screws fastening the top cover to the unit (four per side).
 - Lift the cover straight up.
7. Disconnect the current loop option PCA from the appropriate connector on the motherboard (see Figure 5-1).
8. Place a shunt between the leftmost two pins of the connector (see Figure 5-1).
 - 6 spare shunts (P/N CN0000132) were shipped with the instrument attached to JP1 on the back of the instruments keyboard and display PCA
9. Reattach the top case to the analyzer.
10. The analyzer is now ready to have a voltage-sensing, recording device attached to that output

5.3. Expendable Kits (Options 42C, 42D and 43)

OPTION NUMBER	DESCRIPTION
OPT 42C	1 year's supply of replacement of 47mm dia. particulate filters
OPT 42D	1 full replacement's volume of indicating soda-lime for the external CO ₂ scrubber included with options 51 & 53 (approximate active lifetime: 1 year)
OPT 43	Options 42 C & 42D

5.4. Calibration Valves Options

There are four available options involving Zero/Span/Shutoff valves. From an operational and software standpoint, all of the options are the same, only the source of the span and zero gases are different.

5.4.1. Zero/Span/Shutoff Valve (Option 50)

This option requires that both zero air and span gas be supplied from external sources. It is specifically designed for applications where span gas will be supplied from a pressurized bottle of calibrated CO₂ gas. A critical flow control orifice, internal to the instrument ensures that the proper flow rate is maintained. An internal vent line, isolated by a shutoff valve ensures that the gas pressure of the span gas is reduced to ambient atmospheric pressure. Normally zero air would be supplied from zero air modules such as a Teledyne Instruments Model 701.

In order to ensure that span gas does not migrate backwards through the vent line and alter the concentration of the span gas, a gas line not less than 2 meters in length should be attached to the vent span outlet on the rear panel of the analyzer. To prevent the buildup of back pressure, this vent line should not be greater than 10 meters in length.

The following table describes the state of each valve during the analyzer's various operational modes.

Table 5-1: Zero/Span Valve Operating States for Options 50 & 51

MODE	VALVE	CONDITION
SAMPLE (Normal State)	Sample/Cal	Open to SAMPLE inlet
	Zero/Span	Open to IZS inlet
	Shutoff Valve	Closed
ZERO CAL	Sample/Cal	Open to ZERO/SPAN valve
	Zero/Span	Open to IZS inlet
	Shutoff Valve	Closed
SPAN CAL	Sample/Cal	Open to ZERO/SPAN valve
	Zero/Span	Open to SHUTOFF valve
	Shutoff Valve	Open to PRESSURE SPAN Inlet

The minimum span gas flow rate required for this option is 800 cm³/min.

The state of the zero/span valves can also be controlled:

- Manually from the analyzer's front panel by using the **SIGNAL I/O** controls located under the **DIAG** Menu (Section 6.13.2),
- By activating the instrument's AutoCal feature (Section 7.6),
- Remotely by using the external digital control inputs (Section 6.15.1.2 and Section 7.5.2), or;
- Remotely through the RS-232/485 serial I/O ports (see Appendix A-6 for the appropriate commands).

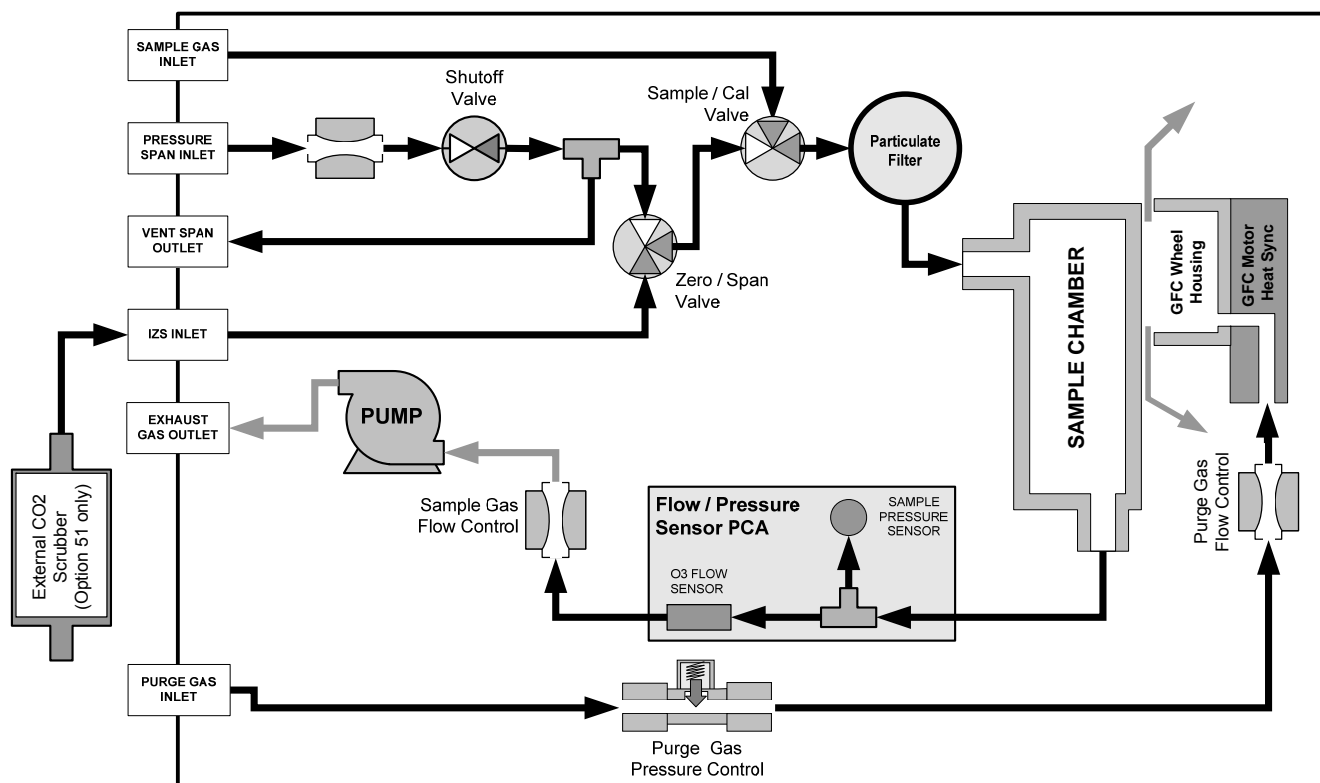

Figure 5-2: Internal Pneumatic Flow – Zero/Span/Shutoff Valves OPT 50 & 51

5.4.2. Zero/Span/Shutoff with External CO₂ Scrubber (Option 51)

Option 51 is operationally and pneumatically identical to Option 50 above (See Section 5.4.1), except that the zero air is generated by an externally mounted zero air scrubber filled with indicating soda-lime that changes color from white to pink as it becomes saturated.

5.4.3. Zero/Span Valve (Option 52)

This valve option is intended for applications where zero air is supplied by a zero air generator like the Teledyne Instruments Model 701 and span gas are being supplied by Gas Dilution Calibrator like the Teledyne Instruments Model 700 or 702. Internal zero/span and sample/cal valves control the flow of gas through the instrument, but because the calibrator limits the flow of span gas no shutoff valve is required.

In order to ensure that span gas does not migrate backwards through the vent line and alter the concentration of the span gas, a gas line not less than 2 meters in length should be attached to the vent span outlet on the rear panel of the analyzer. To prevent the buildup of back pressure, this vent line should not be greater than 10 meters in length.

The following table describes the state of each valve during the analyzer's various operational modes.

Table 5-2: Zero/Span Valve Operating States for Options 52 & 53

Mode	Valve	Condition
SAMPLE (Normal State)	Sample/Cal	Open to SAMPLE inlet
	Zero/Span	Open to IZS inlet
ZERO CAL	Sample/Cal	Open to ZERO/SPAN valve
	Zero/Span	Open to IZS inlet
SPAN CAL	Sample/Cal	Open to ZERO/SPAN valve
	Zero/Span	Open to PRESSURE SPAN inlet

The minimum span gas flow rate required for this option is 800 cm³/min.

The state of the zero/span valves can also be controlled:

- Manually from the analyzer's front panel by using the **SIGNAL I/O** controls located under the **DIAG** Menu (Section 6.13.2),
- By activating the instrument's AutoCal feature (Section 7.6),
- Remotely by using the external digital control inputs (Sections 6.15.1.2 and 7.5.2), or
- Remotely through the RS-232/485 serial I/O ports (see Appendix A-6).

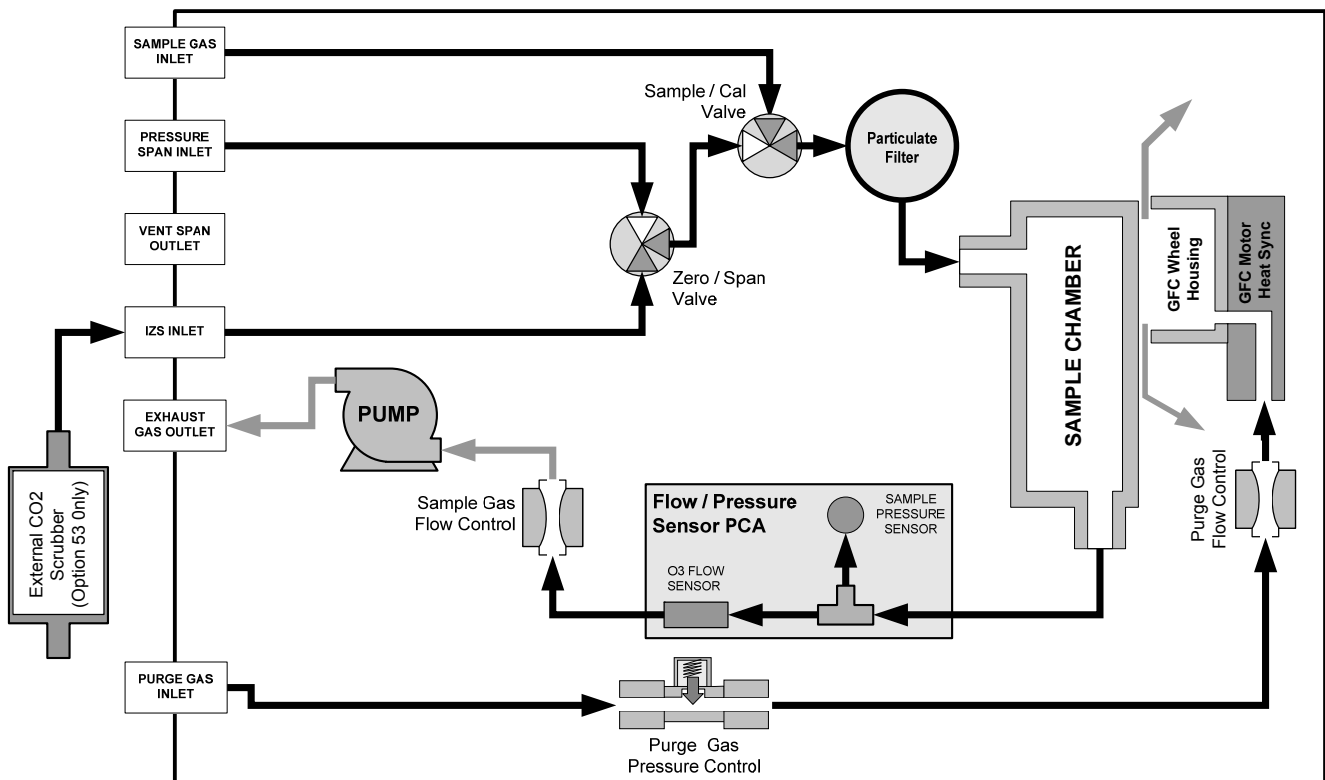

Figure 5-3: Internal Pneumatic Flow – Zero/Span OPT 52 & 53

5.4.4. Zero/Span Valve with External CO₂ Scrubber (Option 53)

Option 53 is operationally and pneumatically identical to Option 52 above (See Section 5.4.3), except that the zero air is generated by an externally mounted zero air scrubber filled with indicating soda-lime that changes color from white to pink as it becomes saturated.

5.5. Communication Options

5.5.1. RS232 Modem Cable (Option 60)

The analyzer can have come standard with a shielded, straight-through DB-9F to DB-9F cable of about 1.8 m length, which should fit most computers of recent build. This cable can be ordered as Option 60.

Option 60A consists of a shielded, straight-through serial cable of about 1.8 m length to connect the analyzer's COM1 port to a computer, a code activated switch or any other communications device that is equipped with a DB-25 female connector. The cable is terminated with one DB-9 female connector and one DB-25 male connector. The DB-9 connector fits the analyzer's COM1 port.

Some older computers or code activated switches with a DB-25 serial connector will need a different cable or an appropriate adapter.

5.5.2. RS-232 Multidrop (Option 62)

The multidrop option is used with any of the RS-232 serial ports to enable communications of up to eight analyzers with the host computer over a chain of RS-232 cables via the instrument's COM1 Port. It is subject to the distance limitations of the RS 232 standard.

The option consists of a small printed circuit assembly, which is plugs into to the analyzer's CPU card (see Figure 5-4) and is connected to the RS-232 and COM2 DB9 connectors on the instrument's back panel via a cable to the motherboard. One option 62 is required for each analyzer along with one 6' straight-through, DB9 male → DB9 Female cable (P/N WR0000101).

This option can be installed in conjunction with the Ethernet option (Option 63) allowing the instrument to communicate on both types of networks simultaneously. For more information on using and setting up this option (See Section 6.11.7)

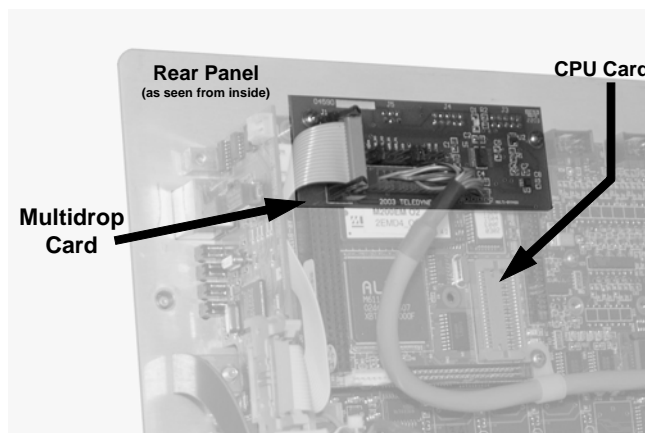

Figure 5-4: M360E Multidrop Card

5.5.3. Ethernet (Option 63)

When installed, this option is electronically connected to the instrument's COM2 serial port making that port no longer available for RS-232/RS-485 communications through the COM2 connector on the rear panel. The option consists of a Teledyne Instruments designed Ethernet card (see Figure 5-5), which is mechanically attached to the instrument's rear panel (see Figure 5-6). A 7-foot long CAT-5 network cable, terminated at both ends with standard RJ-45 connectors, is included as well. Maximum communication speed is limited by the RS-232 port to 115.2 kBaud.

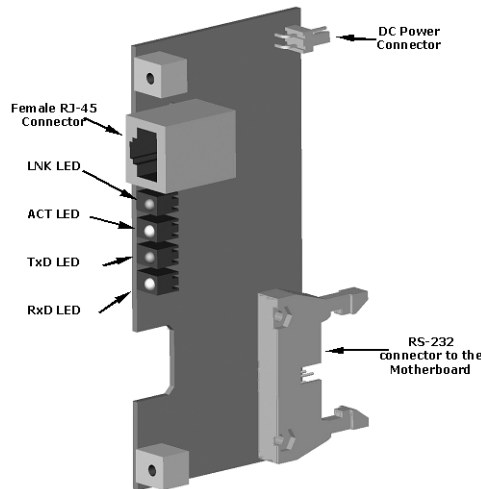

Figure 5-5: M360E Ethernet Card

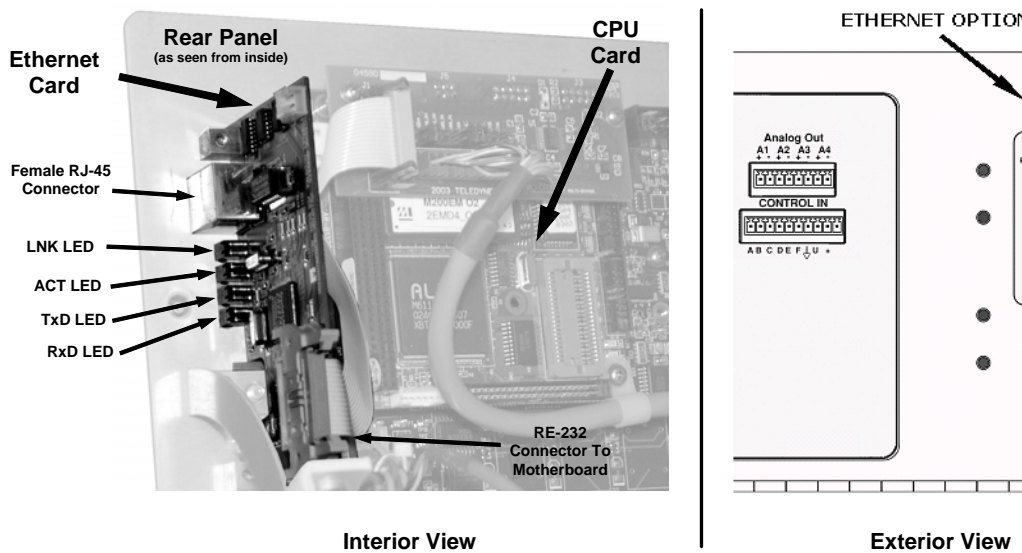

Figure 5-6: M360E Rear Panel with Ethernet Installed

This option can be installed in conjunction with the RS-2323 multidrop (option 62) allowing the instrument to communicate on both types of networks simultaneously. For more information on using and setting up this option. See Section 6.11.6)

5.6. Oxygen Sensor (OPT 65)

5.6.1. Theory of Operation

5.6.1.1. Paramagnetic measurement of O₂

The oxygen sensor used in the M360E analyzer utilizes the fact that oxygen is attracted into strong magnetic field; most other gases are not, to obtain fast, accurate oxygen measurements.

The sensor's core is made up of two nitrogen filled glass spheres, which are mounted on a rotating suspension within a magnetic field (Figure 5-7). A mirror is mounted centrally on the suspension and light is shone onto the mirror that reflects the light onto a pair of photocells. The signal generated by the photocells is passed to a feedback loop, which outputs a current to a wire winding (in effect, a small DC electric motor) mounted on the suspended mirror.

Oxygen from the sample stream is attracted into the magnetic field displacing the nitrogen filled spheres and causing the suspended mirror to rotate. This changes the amount of light reflected onto the photocells and therefore the output levels of the photocells. The feedback loop increases the amount of current fed into the winding in order to move the mirror back into its original position. The more O₂ present, the more the mirror moves and the more current is fed into the winding by the feedback control loop.

A sensor measures the amount of current generated by the feedback control loop which is directly proportional to the concentration of oxygen within the sample gas mixture (see Figure 5-7).

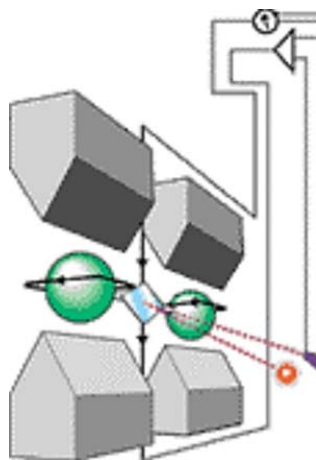

Figure 5-2: Oxygen Sensor - Principle of Operation

5.6.1.2. Operation within the M360E Analyzer

The oxygen sensor option is transparently integrated into the core analyzer operation. All functions can be viewed or accessed through the front panel, just like the functions for CO₂

- The O₂ concentration is displayed in the upper right-hand corner, alternating with CO₂ concentration.
- Test functions for O₂ slope and offset are viewable from the front panel along with the analyzer's other test functions.
- O₂ sensor calibration is performed via the front panel **CAL** function and is performed in a nearly identical manner as the standard CO₂ calibration. See Section 3.3.1 for more details.
- Stability of the O₂ sensor can be viewed via the front panel (see Section 3.3.2.1).
- A signal representing the currently measured O₂ concentration is available.

The O₂ concentration range is 0-100% (user selectable) with 0.1% precision and accuracy and is available to be output via the instrument's analog output channel **A3** (See Section 6.13.4).

The temperature of the O₂ sensor is maintained at a constant 50° C by means of a PID loop and can be viewed on the front panel as test function **O2 TEMP**.

The O₂ sensor assembly itself does not have any serviceable parts and is enclosed in an insulated canister.

5.6.1.3. Pneumatic Operation of the O₂ Sensor

- Pneumatically, the O₂ sensor is connected to the bypass manifold and draws a flow of about 120 cm³/min in addition to the normal sample flow rate and is separately controlled with its own critical flow orifice. Figure 5-8 shows the internal pneumatics of the M360E with the O₂ Sensor installed.

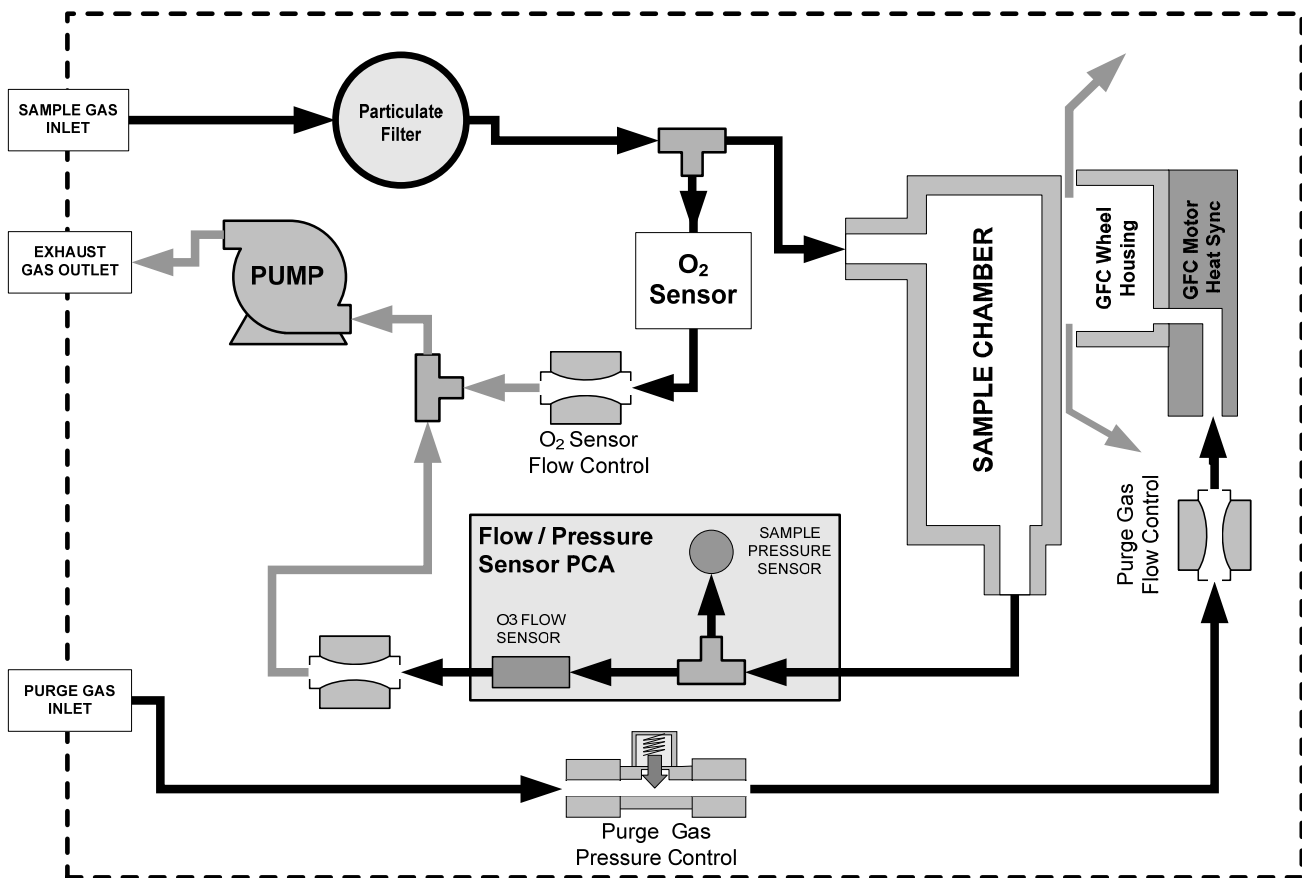

Figure 5-3: M360E – Internal Pneumatics with O₂ Sensor Option 65

5.7. Additional Manuals

5.7.1. Printed Manuals (Option 70)

Additional printed copies of this manual are available from Teledyne Instruments

5.7.2. Manual on CD (Part number 045840200)

This operator's manual is also available on CD. The electronic document is stored in Adobe Systems Inc. Portable Document Format (PDF) and is viewable with Adobe Acrobat Reader[®] software, downloadable for free at <http://www.adobe.com/>

The CD version of the manual has many advantages:

- Fully searchable text.
- Hypertext links for figures, tables, table of contents and embedded references for quick access of individual manual portions.
- A list of thumbnails, chapters and s displayed at the left of the text.
- Internet links embedded in the manual will take you to the corresponding web site (requires an internet connection).

5.8. Extended Warranty (Options 92 & 93)

Two options are available for extending Teledyne Instruments' standard warranty (Section 2.3). Both options have to be specified upon ordering the analyzer.

OPTION NUMBER	DESCRIPTION
OPT 92	Extends warranty to cover a two (2) year period from the date of purchase.
OPT 93	Extends warranty to cover a five (5) year period from the date of purchase.

5.9. Special Software Features

5.9.1. Dilution Ratio Option

The Dilution Ration Option is a software option that is designed for applications where the Sample gas is diluted before being analyzed by the Model 360E. Typically this occurs in Continuous Emission Monitoring (CEM) applications where the quality of gas in a smoke stack is being tested and the sampling method used to remove the gas from the stack dilutes the gas.

Once the degree of dilution is known, this feature allows the user to add an appropriate scaling factor to the analyzer's CO₂ concentration calculation so that the Measurement Range and concentration values displayed on the instrument's Front Panel Display and reported via the Analog and Serial Outputs reflect the undiluted values.

Instructions for using the dilution ratio option can be found in Section 6.8.7.

5.9.2. Maintenance Mode Switch

API's instruments can be equipped with a switch that places the instrument in maintenance mode. When present, the switch accessed by opening the hinged front panel and is located on the rearward facing side of the display/keyboard driver PCA; on the left side; near the particulate filter.

When in maintenance mode the instrument ignores all commands received via the COMM ports that alter the operation state of the instrument. This includes all calibration commands, diagnostic menu commands and the reset instrument command. The instrument continues to measure concentration and send data when requested.

This option is of particular use for instruments connected to multidrop or Hessen protocol networks.

5.9.3. Second Language Switch

API's instruments can be equipped with switch that activates an alternate set of display message in a language other than the instruments default language. When present, the switch accessed by opening the hinged front panel and is located on the rearward facing side of the display/keyboard driver PCA; on the right side.

To activate this feature, the instrument must also have a specially programmed Disk on Chip containing the second language.

User Notes

6. OPERATING INSTRUCTIONS

To assist in navigating the analyzer's software, a series of menu trees can be found in Appendix A-1 of this manual.

NOTES

The flow charts appearing in this contain typical representations of the analyzer's display during the various operations being described. These representations may differ slightly from the actual display of your instrument.

The **ENTR** key may disappear if you select a setting that is invalid or out of the allowable range for that parameter, such as trying to set the 24-hour clock to 25:00:00. Once you adjust the setting to an allowable value, the **ENTR** key will re-appear.

6.1. Overview of Operating modes

The M360E software has a variety of operating modes. Most commonly, the analyzer will be operating in **SAMPLE** mode. In this mode, a continuous read-out of the CO₂ concentration is displayed on the front panel and output as an analog voltage from rear panel terminals, calibrations can be performed, and **TEST** functions and **WARNING** messages can be examined.

The second most important operating mode is **SETUP** mode. This mode is used for performing certain configuration operations, such as for the iDAS system, the reporting ranges, or the serial (RS-232/RS-485/Ethernet) communication channels. The **SET UP** mode is also used for performing various diagnostic tests during troubleshooting.

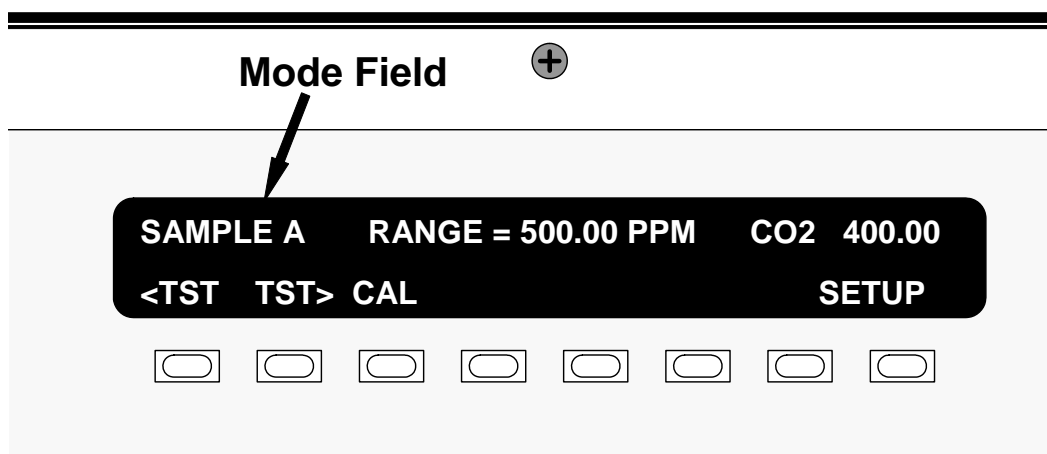

Figure 6-1: Front Panel Display

The mode field of the front panel display indicates to the user which operating mode the unit is currently running.

Besides **SAMPLE** and **SETUP**, other modes the analyzer can be operated in are:

Table 6-1: Analyzer Operating modes

MODE	MEANING
DIAG	One of the analyzer's diagnostic modes is being utilized (See Section 6.13).
M-P CAL	This is the basic, multi-point calibration mode of the instrument and is activated by pressing the CAL key.
SAMPLE	Sampling normally, flashing indicates adaptive filter is on.
SAMPLE A	Indicates that unit is in SAMPLE Mode and AUTOCAL feature is activated.
SETUP ¹	SETUP mode is being used to configure the analyzer (CO ₂ sampling will continue during this process).
SPAN CAL A	Unit is performing span cal procedure initiated automatically by the analyzer's AUTOCAL feature.
SPAN CAL M	Unit is performing span cal procedure initiated manually by the user.
SPAN CAL R	Unit is performing span cal procedure initiated remotely via the RS-232, RS-4485 or digital i/o control inputs.
ZERO CAL A	Unit is performing zero cal procedure initiated automatically by the analyzer's AUTOCAL feature.
ZERO CAL M	Unit is performing zero cal procedure initiated manually by the user.
ZERO CAL R	Unit is performing zero cal procedure initiated remotely via the RS-232, RS-4485 or digital I/O control inputs.

¹ The revision of the Teledyne Instruments software installed in this analyzer will be displayed following the word **SETUP**. E.g. "SETUP G.4"

Finally, the various **CAL** modes allow calibration of the analyzer. Because of its importance, this mode is described separately in Chapter 7.

6.2. Sample Mode

This is the analyzer's standard operating mode. In this mode the instrument is analyzing the gas in the sample chamber, calculating CO₂ concentration and reporting this information to the user via the front panel display, the analog outputs and, if set up properly, the RS-232/485/Ethernet ports.

NOTE

A value of "XXXX" displayed in the CO₂ Concentration field means that the M/R ratio is invalid because CO₂ REF is either too high (> 4950 mVDC) or too low (< 1250 VDC).

6.2.1. Test Functions

A series of test functions is available at the front panel while the analyzer is in **SAMPLE** mode. These parameters provide information about the present operating status of the instrument and are useful during troubleshooting (Section 11.1.2). They can also be recorded in one of the iDAS channels (Section 6.7) for data analysis. To view the test functions, press one of the **<TST TST>** keys repeatedly in either direction.

Table 6-2: Test Functions Defined

PARAMETER	DISPLAY TITLE	UNITS	MEANING
Range	RANGE RANGE1 ¹ RANGE2 ¹	PPB, PPM, UGM, MGM	The full scale limit at which the reporting range of the analyzer is currently set. THIS IS NOT the Physical Range of the instrument. See Section 6.8.1 for more information.
O ₂ Range	O2 RANGE	%	The range setting for the O ₂ Sensor
Stability	STABIL	PPB, PPM UGM, MGM	Standard deviation of CO ₂ concentration readings. Data points are recorded every ten seconds using the last 25 data points.
CO ₂ Measure	MEAS	MV	The demodulated, peak IR detector output during the measure portion of the CFG Wheel cycle.
CO ₂ Reference	REF	MV	The demodulated, peak IR detector output during the reference portion of the CFG wheel cycle.
Measurement / Reference Ratio	MR Ratio	-	The result of CO2 MEAS divided by CO2 REF . This ratio is the primary value used to compute CO ₂ concentration. The value displayed is not linearized.
Sample Pressure	PRES	In-Hg-A	The absolute pressure of the Sample gas as measured by a pressure sensor located inside the sample chamber.
Sample Flow	SAMPLE FL	cc/min	Sample mass flow rate. This is computed from the differential between the pressures measured up-stream and down-stream of the sample critical flow orifice pressures.
Sample Temperature	SAMP TEMP	°C	The temperature of the gas inside the sample chamber.
Bench Temperature	BENCH TEMP	°C	Optical bench temperature.
Wheel Temperature	WHEEL TEMP	°C	Filter wheel temperature.
Box Temperature	BOX TEMP	°C	The temperature inside the analyzer chassis.
O ₂ Cell Temperature ²	O2 CELL TEMP²	°C	O ₂ sensor cell temperature.
Photo-detector Temp. Control Voltage	PHT DRIVE	mV	The drive voltage being supplied to the thermoelectric coolers of the IR photo-detector by the sync/demod Board.
Slope	SLOPE	-	The sensitivity of the instrument as calculated during the last calibration activity. The SLOPE parameter is used to set the span calibration point of the analyzer.
Offset	OFFSET	-	The overall offset of the instrument as calculated during the last calibration activity. The OFFSET parameter is used to set the zero point of the analyzer response.
O ₂ Sensor Slope ₂	O2 SLOPE	-	O ₂ slope, computed during zero/span calibration.
O ₂ Sensor Offset ₂	O2 OFFSET	-	O ₂ offset, computed during zero/span calibration.
Test channel output signal	TEST	mV, mA	Displays the signal level of the TEST analog output channel. Only appears when the TEST channel has been activated.
Current Time	TIME	-	The current time. This is used to create a time stamp on iDAS readings, and by the AUTOCAL feature to trigger calibration events.

¹ Only appears when the instrument's reporting range mode is set for **DUAL** or **AUTO**

² Only appears when the optional O₂ sensor is installed.

To view the TEST Functions press the following Key sequence:

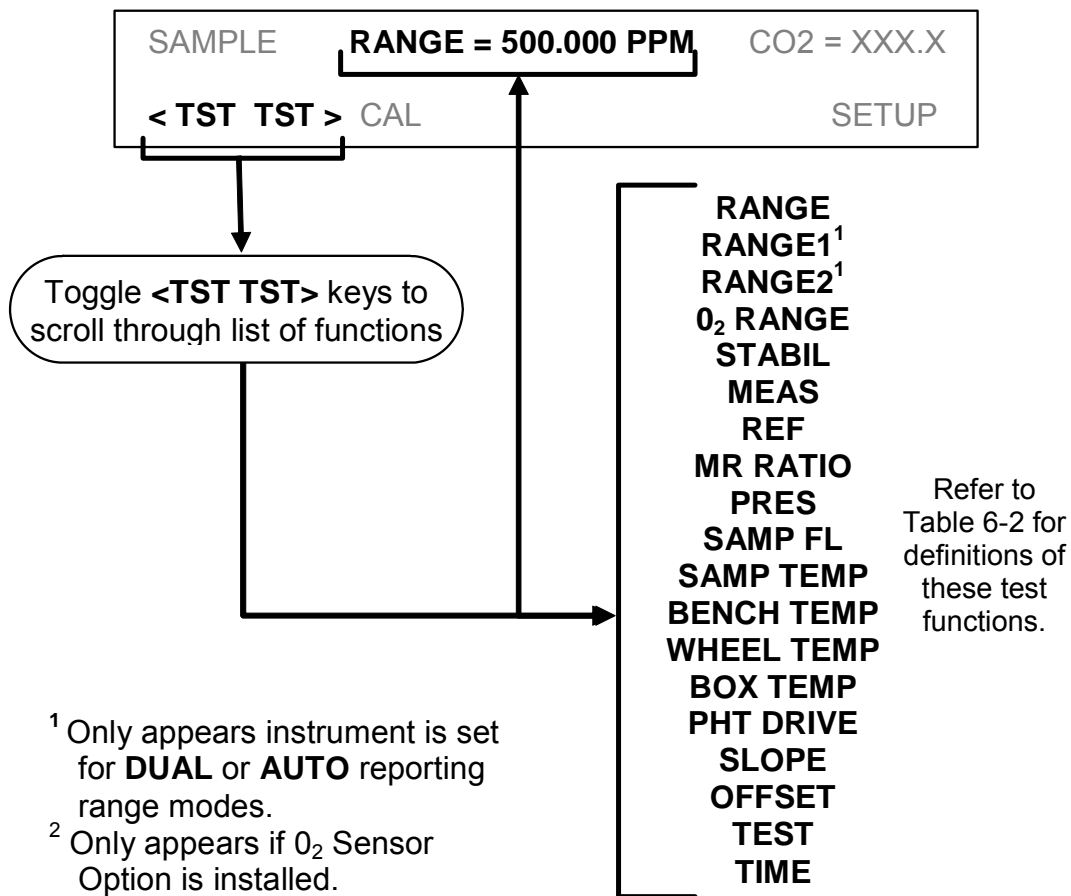

Figure 6-3: Viewing M360E TEST Functions

NOTE

A value of "XXXX" displayed for any of the TEST functions indicates an out-of-range reading or the analyzer's inability to calculate it.

All pressure measurements are represented in terms of absolute pressure. Absolute, atmospheric pressure is 29.92 in-Hg-A at sea level. It decreases about 1 in-Hg per 300 m gain in altitude. A variety of factors such as air conditioning and passing storms can cause changes in the absolute atmospheric pressure.

6.2.2. Warning Messages

The most common instrument failures will be reported as a warning on the analyzer's front panel and through the COM ports. Section 11.1.1 explains how to use these messages to troubleshoot problems. Section 3.2.3 shows how to view and clear warning messages.

Table 6-3 lists all warning messages for the current version of software.

Table 6-3: List of Warning Messages

MESSAGE	MEANING
ANALOG CAL WARNING	The instrument's A/D circuitry or one of its analog outputs is not calibrated.
BENCH TEMP WARNING	The Temperature of the optical bench is outside the specified limits.
BOX TEMP WARNING	Remote span calibration failed while the dynamic span feature was set to turned on
CANNOT DYN SPAN	Remote zero calibration failed while the dynamic zero feature was set to turned on
CANNOT DYN ZERO	Configuration was reset to factory defaults or was erased.
CONC ALRM1 WARNING	Concentration alarm 1 is enabled and the measured CO ₂ level is ≥ the set point.
CONC ALRM2 WARNING	Concentration alarm 2 is enabled and the measured CO ₂ level is ≥ the set point.
CONFIG INITIALIZED	Configuration storage was reset to factory configuration or erased.
DATA INITIALIZED	iDAS data storage was erased.
O2 CELL TEMP WARN	O ₂ sensor cell temperature outside of warning limits.
PHOTO TEMP WARNING	The temperature of the IR photometer is outside the specified limits.
REAR BOARD NOT DET	The CPU is unable to communicate with the motherboard.
RELAY BOARD WARN	The firmware is unable to communicate with the relay board.
SAMPLE FLOW WARN	The flow rate of the sample gas is outside the specified limits.
SAMPLE PRESS WARN	Sample gas pressure outside of operational parameters.
SAMPLE TEMP WARN	The temperature of the sample gas is outside the specified limits.
SOURCE WARNING	The IR source may be faulty.
SYSTEM RESET	The computer was rebooted.
WHEEL TEMP WARNING	The Gas Filter Correlation wheel temperature is outside the specified limits.

To view and clear warning messages

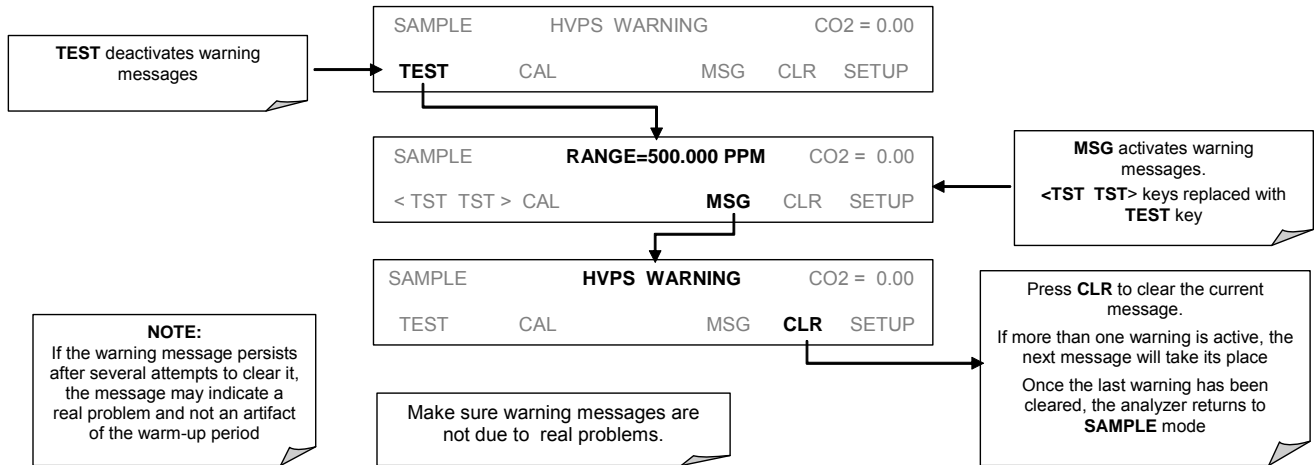

Figure 6-3 Viewing and Clearing M360E WARNING Messages

6.3. Calibration Mode

Pressing the **CAL** key switches the M360E into multi-point calibration mode. In this mode, the user can calibrate the instrument or check the instruments calibration with the use of calibrated zero or span gases.

If the instrument includes either the zero/span valve option or IZS option, the display will also include **CALZ** and **CALS** keys. Pressing either of these keys also puts the instrument into multipoint calibration mode.

- The **CALZ** key is used to initiate a calibration of the zero point.
- The **CALS** key is used to calibrate the span point of the analyzer. It is recommended that this span calibration is performed at 90% of full scale of the analyzer's currently selected reporting range.

Because of their critical importance and complexity, calibration operations are described in detail in Chapter 7 of this manual. For more information concerning the zero/span, zero/span/shutoff and IZS valve options, See Section 5.4.

6.4. SETUP MODE

The **SETUP** mode contains a variety of choices that are used to configure the analyzer's hardware and software features, perform diagnostic procedures, gather information on the instruments performance and configure or access data from the internal data acquisition system (iDAS). For a visual representation of the software menu trees, refer to Appendix A-1.

The areas access under the Setup mode are:

Table 6-4: Primary Setup Mode Features and Functions

MODE OR FEATURE	KEYPAD LABEL	DESCRIPTION	MANUAL SECTION
Analyzer Configuration	CFG	Lists key hardware and software configuration information	6.5
Auto Cal Feature	ACAL	Used to set up and operate the AutoCal feature. Only appears if the analyzer has one of the internal valve options installed	7.6
Internal Data Acquisition (iDAS)	DAS	Used to set up the iDAS system and view recorded data	6.7
Analog Output Reporting Range Configuration	RNGE	Used to configure the output signals generated by the instruments Analog outputs.	6.8
Calibration Password Security	PASS	Turns the calibration password feature ON/OFF	6.9
Internal Clock Configuration	CLK	Used to Set or adjust the instrument's internal clock	6.10
Advanced SETUP features	MORE	This button accesses the instruments secondary setup menu	See Table 6-5

Table 6-5: Secondary Setup Mode Features and Functions

MODE OR FEATURE	KEYPAD LABEL	DESCRIPTION	MANUAL SECTION
External Communication Channel Configuration	COMM	Used to set up and operate the analyzer's various external I/O channels including RS-232; RS 485, modem communication and/or Ethernet access.	6.11 & 6.15
System Status Variables	VARS	Used to view various variables related to the instruments current operational status	6.12
System Diagnostic Features	DIAG	Used to access a variety of functions that are used to configure, test or diagnose problems with a variety of the analyzer's basic systems	6.13
CO ₂ Concentration Alarms	ALRM	Used to activate the analyzer's two gas concentration status alarms and set the alarm limits	6.14

NOTE

Any changes made to a variable during one of the following procedures is not acknowledged by the instrument until the ENTR Key is pressed

If the EXIT key is pressed before the ENTR key, the analyzer will beep alerting the user that the newly entered value has been lost.

6.5. SETUP → CFG: Viewing the Analyzer's Configuration Information

Pressing the CFG key displays the instrument configuration information. This display lists the analyzer model, serial number, firmware revision, software library revision, CPU type and other information. Use this information to identify the software and hardware when contacting customer service. Special instrument or software features or installed options may also be listed here.

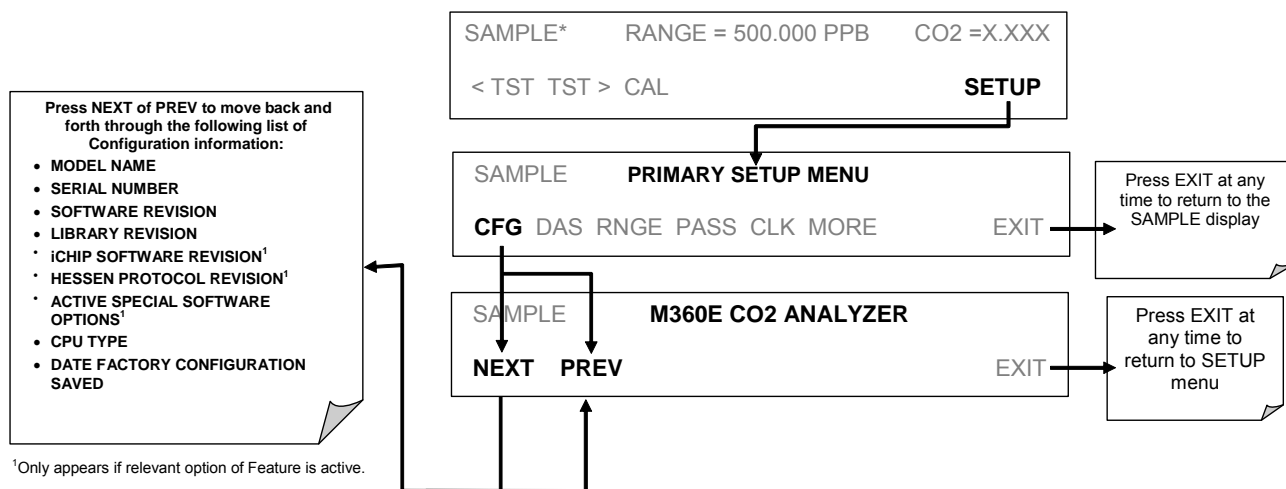

6.6. SETUP → ACAL: Automatic Calibration

Instruments with one of the internal valve options installed can be set to automatically run calibration procedures and calibration checks. These automatic procedures are programmed using the submenus and functions found under the **ACAL** menu.

A menu tree showing the **ACAL** menu's entire structure can be found in Appendix A-1 of this manual.

Instructions for using the **ACAL** feature are located in the Section 7.6 of this manual along with all other information related to calibrating the M360E analyzer.

6.7. SETUP → DAS: Using the Data Acquisition System (iDAS)

The M360E analyzer contains a flexible and powerful, internal data acquisition system (iDAS) that enables the analyzer to store concentration and calibration data as well as a host of diagnostic parameters. The iDAS of the M360E can store up to about one million data points, which can, depending on individual configurations, cover days, weeks or months of valuable measurements. The data are stored in non-volatile memory and are retained even when the instrument is powered off. Data are stored in plain text format for easy retrieval and use in common data analysis programs (such as spreadsheet-type programs).

The iDAS is designed to be flexible, users have full control over the type, length and reporting time of the data. The iDAS permits users to access stored data through the instrument's front panel or its communication ports. Using APICOM, data can even be retrieved automatically to a remote computer for further processing.

The principal use of the iDAS is logging data for trend analysis and predictive diagnostics, which can assist in identifying possible problems before they affect the functionality of the analyzer. The secondary use is for data analysis, documentation and archival in electronic format.

To support the iDAS functionality, Teledyne Instruments offers APICOM, a program that provides a visual interface for remote or local setup, configuration and data retrieval of the iDAS (Section 6.7). The APICOM manual, which is included with the program, contains a more detailed description of the iDAS structure and configuration.

The M360E is configured with a basic iDAS configuration, which is enabled by default. New data channels are also enabled by default but each channel may be turned off for later or occasional use. Note that iDAS operation is suspended while its configuration is edited through the front panel. To prevent such data loss, it is recommended to use the APICOM graphical user interface for iDAS changes.

The green SAMPLE LED on the instrument front panel, which indicates the analyzer status, also indicates certain aspects of the iDAS status:

Table 6-6: Front Panel LED Status Indicators for iDAS

LED STATE	iDAS Status
OFF	System is in calibration mode. Data logging can be enabled or disabled for this mode. Calibration data are typically stored at the end of calibration periods, concentration data are typically not sampled, diagnostic data should be collected.
BLINKING	Instrument is in hold-off mode, a short period after the system exits calibrations. iDAS channels can be enabled or disabled for this period. Concentration data are typically disabled whereas diagnostic should be collected.
ON	Sampling normally.

The iDAS can be disabled only by disabling or deleting its individual data channels.

6.7.1. iDAS Structure

The iDAS is designed around the feature of a "record". A record is a single data point of one parameter, stored in one (or more) data channels and generated by one of several triggering event. The entire iDAS configuration is stored in a script, which can be edited from the front panel or downloaded, edited and uploaded to the instrument in form of a string of plain-text lines through the communication ports.

iDAS data are defined by the PARAMETER type and are stored through different triggering EVENTS in data CHANNELS, which relate triggering events to data parameters and define certain operational functions related to the recording and reporting of the data.

6.7.1.1. iDAS Channels

The key to the flexibility of the iDAS is its ability to store a large number of combinations of triggering events and data parameters in the form of data channels. Users may create up to 20 data channels and each channel can contain one or more parameters. For each channel one triggering event is selected and up to 50 data parameters, which can be the same or different between channels. Each data channel has several properties that define the structure of the channel and allow the user to make operational decisions regarding the channel (Table 6-7).

Table 6-7: iDAS Data Channel Properties

PROPERTY	DESCRIPTION	DEFAULT	SETTING RANGE
NAME	The name of the data channel.	"NONE"	Up to 6 letters and digits (more with APICOM, but only the first six are displayed on the front panel).
TRIGGERING EVENT	The event that triggers the data channel to measure and store its data parameters. See APPENDIX A-5 for a list of available triggering events.	ATIMER	See Appendix A-5 For a complete list.
NUMBER & PARAMETER LIST	A User-configurable list of data types to be recorded in any given channel. See APPENDIX A-5 for a list of available parameters	1 – DETMES	See Appendix A-5 For a complete list.
STARTING DATE	The starting date when a channel starts collecting data	01-JAN-03	Any actual date in the past or future.
SAMPLE PERIOD	The amount of time between each data point that is averaged into one mean reported every REPORT PERIOD.	000:01:00	000:00:01 to 366:23:59 (Days:Hours:Minutes)
REPORT PERIOD	The amount of time between each channel data point.	000:01:00	000:00:01 to 366:23:59 (Days:Hours:Minutes)
NUMBER OF RECORDS	The number of reports that will be stored in the data file. Once the specified limit has been exceeded, the oldest data are over-written to make space for new data.	100	1 to 1 million, limited by available storage space.
RS-232 REPORT	Enables the analyzer to automatically report channel values to the RS-232 ports.	OFF	OFF or ON
CHANNEL ENABLED	Enables or disables the channel. Provides a convenient means to temporarily disable a data channel.	ON	OFF or ON
CAL HOLD OFF	Disables sampling of data parameters while instrument is in calibration mode. When enabled here – there is also a length of the DAS HOLD OFF after calibration mode, which is set in the VARS menu.	OFF	OFF or ON (Section 6.7.2.11.)

6.7.1.2. iDAS Parameters

Data parameters are types of data that may be measured and stored by the iDAS. For each Teledyne Instruments analyzer model, the list of available data parameters is different, fully defined and not customizable. Appendix A-5 lists firmware specific data parameters for the M360E. iDAS parameters include things like CO₂ concentration measurements, temperatures of the various heaters placed around the analyzer, pressures and flows of the pneumatic subsystem and other diagnostic measurements as well as calibration data such as slope and offset.

Most data parameters have associated measurement units, such as mV, ppb, cm³/min, etc., although some parameters have no units. With the exception of concentration readings, none of these units of measure can be changed. To change the units of measure for concentration readings See Section 6.8.6.

Note

iDAS does not keep track of the unit of each concentration value and iDAS data files may contain concentrations in multiple units if the unit was changed during data acquisition.

Each data parameter has user-configurable functions that define how the data are recorded:

Table 6-8: iDAS Data Parameter Functions

FUNCTION	EFFECT
PARAMETER	Instrument-specific parameter name.
SAMPLE MODE	INST: Records instantaneous reading. AVG: Records average reading during reporting interval. MIN: Records minimum (instantaneous) reading during reporting interval. MAX: Records maximum (instantaneous) reading during reporting interval. SDEV: Records the standard deviation of the data points recorded during the reporting interval.
PRECISION	Decimal precision of parameter value (0-4).
STORE NUM. SAMPLES	OFF: stores only the average (default). ON: stores the average and the number of samples in each average for a parameter. This property is only useful when the AVG sample mode is used. Note that the number of samples is the same for all parameters in one channel and needs to be specified only for one of the parameters in that channel.

Users can specify up to 50 parameters per data channel (the M360E provides about 30 parameters). However, the number of parameters and channels is ultimately limited by available memory.

6.7.1.3. iDAS Triggering Events

Triggering events define when and how the iDAS records a measurement of any given data channel. Triggering events are firmware-specific and a complete list of Triggers for this model analyzer can be found in Appendix A-5. The most commonly used triggering events are:

- **ATIMER**: Sampling at regular intervals specified by an automatic timer. Most trending information is usually stored at such regular intervals, which can be instantaneous or averaged.
- **EXITZR, EXITSP, SLPCHG** (exit zero, exit span, slope change): Sampling at the end of (irregularly occurring) calibrations or when the response slope changes. These triggering events create instantaneous data points, e.g., for the new slope and offset (concentration response) values at the end of a calibration. Zero and slope values are valuable to monitor response drift and to document when the instrument was calibrated.
- **WARNINGS**: Some data may be useful when stored if one of several warning messages appears such as **WTEMPW** (GFC wheel temperature warning) or **PPRESW** (purge pressure warning). This is helpful for trouble-shooting by monitoring when a particular warning occurred.

6.7.2. Default iDAS Channels

A set of default Data Channels has been included in the analyzer's software for logging CO₂ concentration and certain predictive diagnostic data. These default channels include but are not limited to:

CONC: Samples CO₂ concentration at one minute intervals and stores an average every hour with a time and date stamp. Readings during calibration and calibration hold off are not included in the data. By default, the last 800 hourly averages are stored.

PNUMTC: Collects sample flow and sample pressure data at five minute intervals and stores an average once a day with a time and date stamp. This data is useful for monitoring the condition of the pump and critical flow orifice (sample flow) and the sample filter (clogging indicated by a drop in sample pressure) over time to predict when maintenance will be required. The last 360 daily averages (about 1 year) are stored.

CALDAT: Logs new slope and offset every time a zero or span calibration is performed. This Data Channel also records the instrument readings just prior to performing a calibration. This information is useful for performing predictive diagnostics as part of a regular maintenance schedule (See Section 9.1).

STBZRO: Logs the concentration stability, the electronic output of the IR detector of the most recent measure phase and the measure/reference ratio every time the instrument exits the zero calibration mode. Data from the last 200 zero calibrations is stored. A time and date stamp is recorded for every data point logged. This information is useful for performing predictive diagnostics as part of a regular maintenance schedule (See Section 9.1).

STBSPN: Logs the electronic output of the IR detector of the most recent measure phase and the measure/reference ratio every time the instrument exits span calibration mode. Data from the last 200 zero calibrations is stored. A time and date stamp is recorded for every data point logged. This information is useful for performing predictive diagnostics as part of a regular maintenance schedule (See Section 9.1).

TEMP: Samples the analyzer's bench temperature, box temperature and PHT cooler drive voltage every five minutes and records an average once every six hours. Data from the last 400 averaging periods is recorded. A time and date stamp is recorded for every data point logged. This information is useful for performing predictive diagnostics as part of a regular maintenance schedule (See Section 9.1).

Note

The CALDAT, STBZRO and STBSPN channels collect data based on events (e.g. a calibration operation) rather than a timed interval. This does not represent any specific length of time since it is dependent on how often calibrations are performed.

Triggering Events and Data Parameters/Functions for these default channels are:

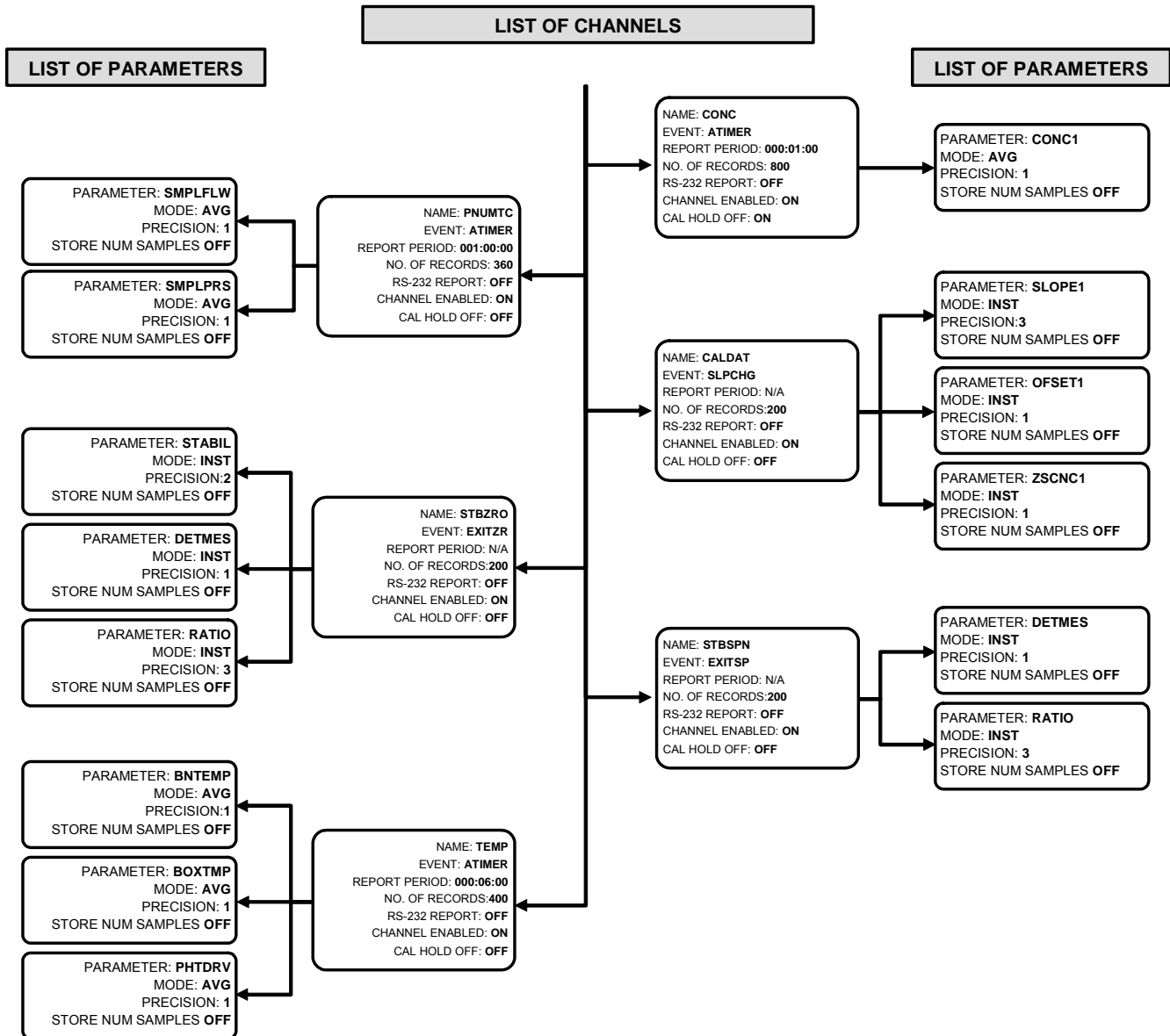

Figure 6-4: Default iDAS Channels Setup

These default Data Channels can be used as they are, or they can be customized from the front panel to fit a specific application. They can also be deleted to make room for custom user-programmed Data Channels.

Appendix A-5 lists the firmware-specific iDAS configuration in plain-text format. This text file can either be loaded into APICOM and then modified and uploaded to the instrument or can be copied and pasted into a terminal program to be sent to the analyzer.

NOTE

Sending an iDAS configuration to the analyzer through its COM ports will replace the existing configuration and will delete all stored data. Back up any existing data and the iDAS configuration before uploading new settings.

These default Data Channels can be used as they are, or they can be customized from the front panel to fit a specific application. They can also be deleted to make room for custom user-programmed Data Channels.

Appendix A-5 lists the firmware-specific iDAS configuration in plain-text format. This text file can either be loaded into APICOM and then modified and uploaded to the instrument or can be copied and pasted into a terminal program to be sent to the analyzer.

NOTE

Sending an iDAS configuration to the analyzer through its COM ports will replace the existing configuration and will delete all stored data. Back up any existing data and the iDAS configuration before uploading new settings.

6.7.2.1. Viewing iDAS Data and Settings

iDAS data and settings can be viewed on the front panel through the following keystroke sequence.

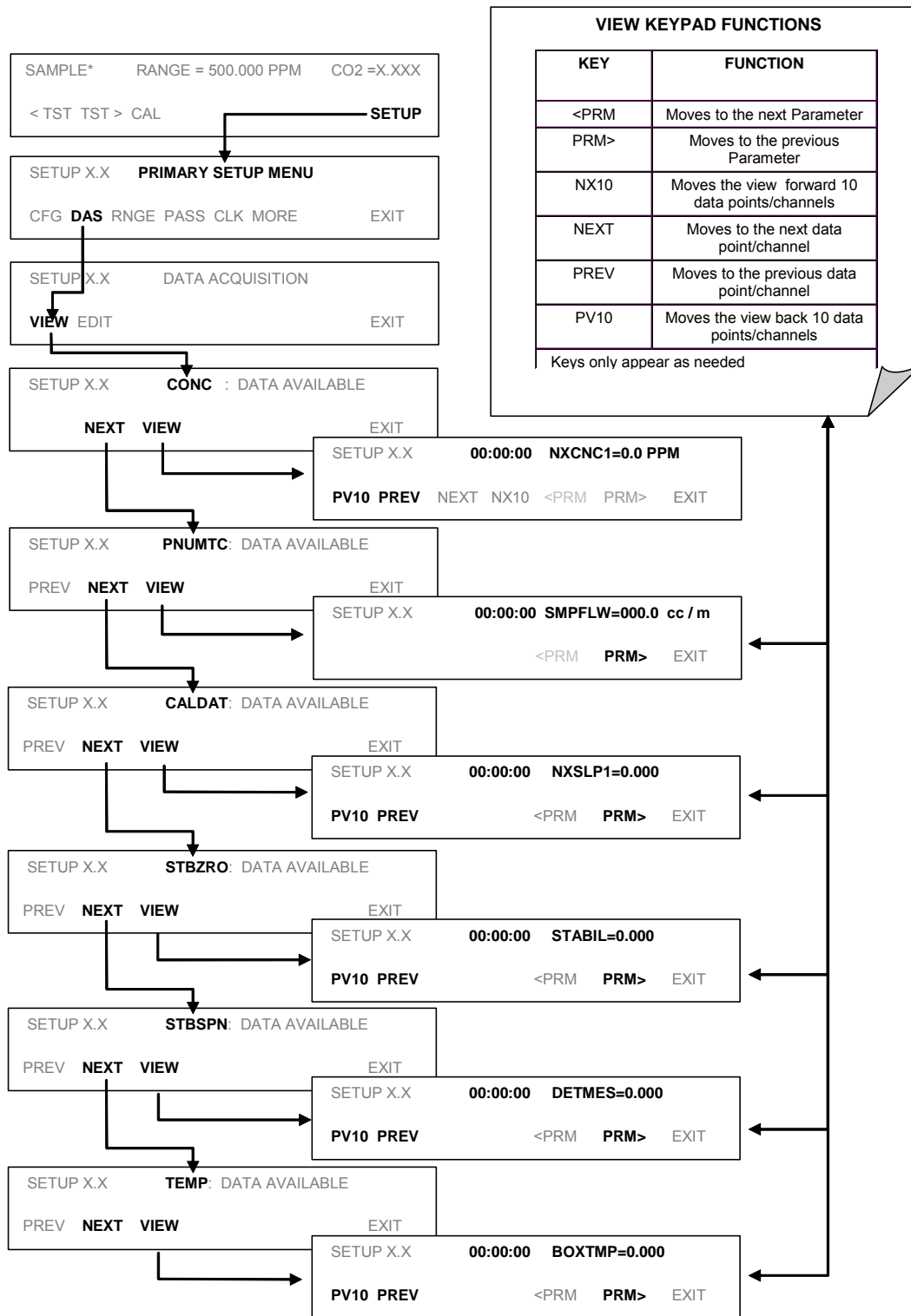

6.7.2.2. Editing iDAS Data Channels

iDAS configuration is most conveniently done through the APICOM remote control program. The following list of key strokes shows how to edit using the front panel.

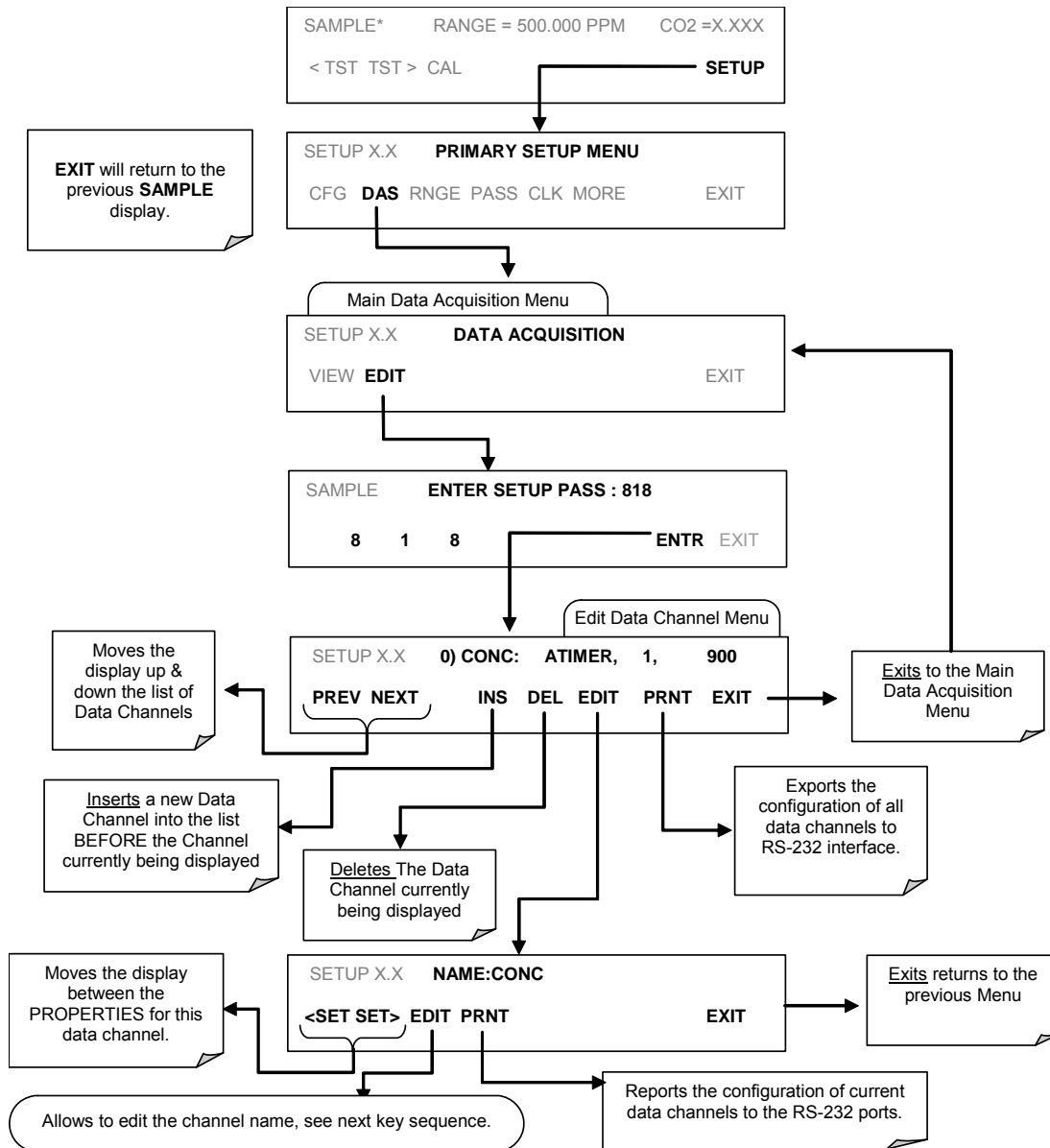

When editing the data channels, the top line of the display indicates some of the configuration parameters. For example, the display line:

0) CONC: ATIMER, 4, 800

translates to the following configuration:

Channel No.: 0
 NAME: CONC
 TRIGGER EVENT: ATIMER
 PARAMETERS: Four parameters are included in this channel
 EVENT: This channel is set up to record 800 data points.

To edit the name of a data channel, follow the above key sequence and then press:

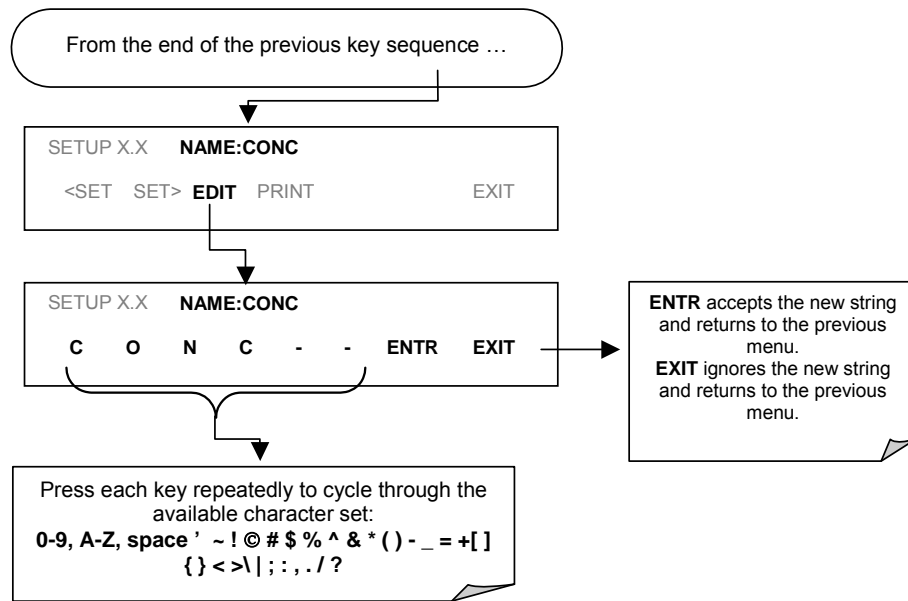

6.7.2.3. Trigger Events

To edit the list of data parameters associated with a specific data channel, press:

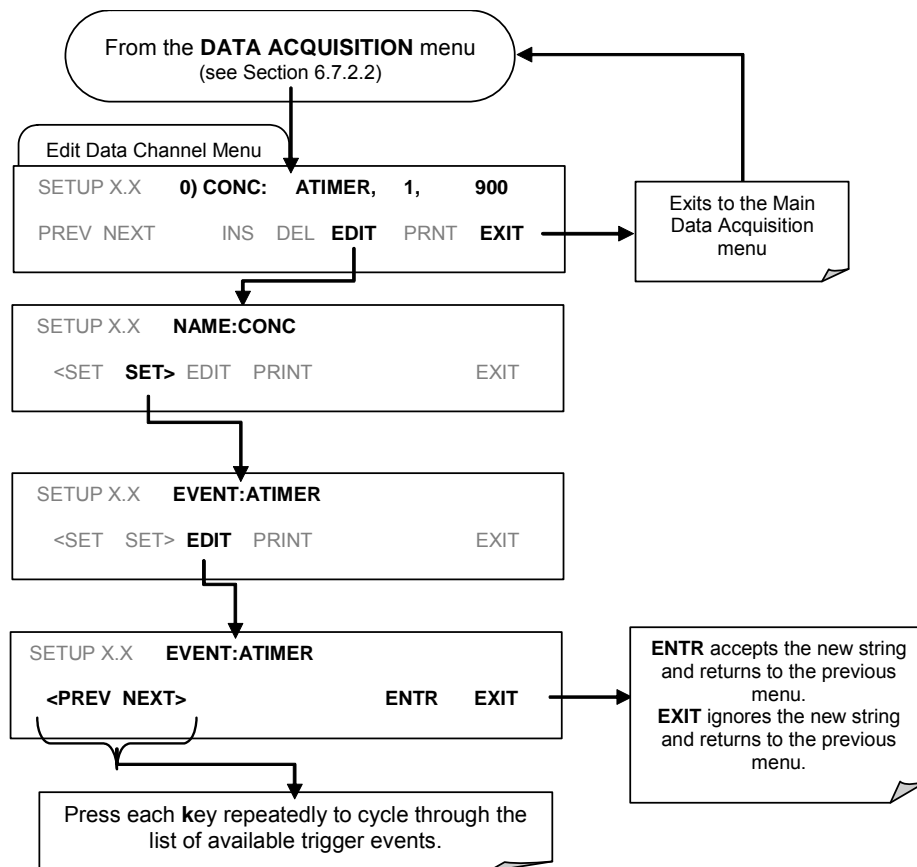

6.7.2.4. Editing iDAS Parameters

Data channels can be edited individually from the front panel without affecting other data channels. However, when editing a data channel, such as during adding, deleting or editing parameters, all data for that particular channel will be lost, because the iDAS can store only data of one format (number of parameter columns etc.) for any given channel. In addition, an iDAS configuration can only be uploaded remotely as an entire set of channels. Hence, remote update of the iDAS will always delete all current channels and stored data.

To modify, add or delete a parameter, follow the instruction shown in Section 6.7.2.2 then press:

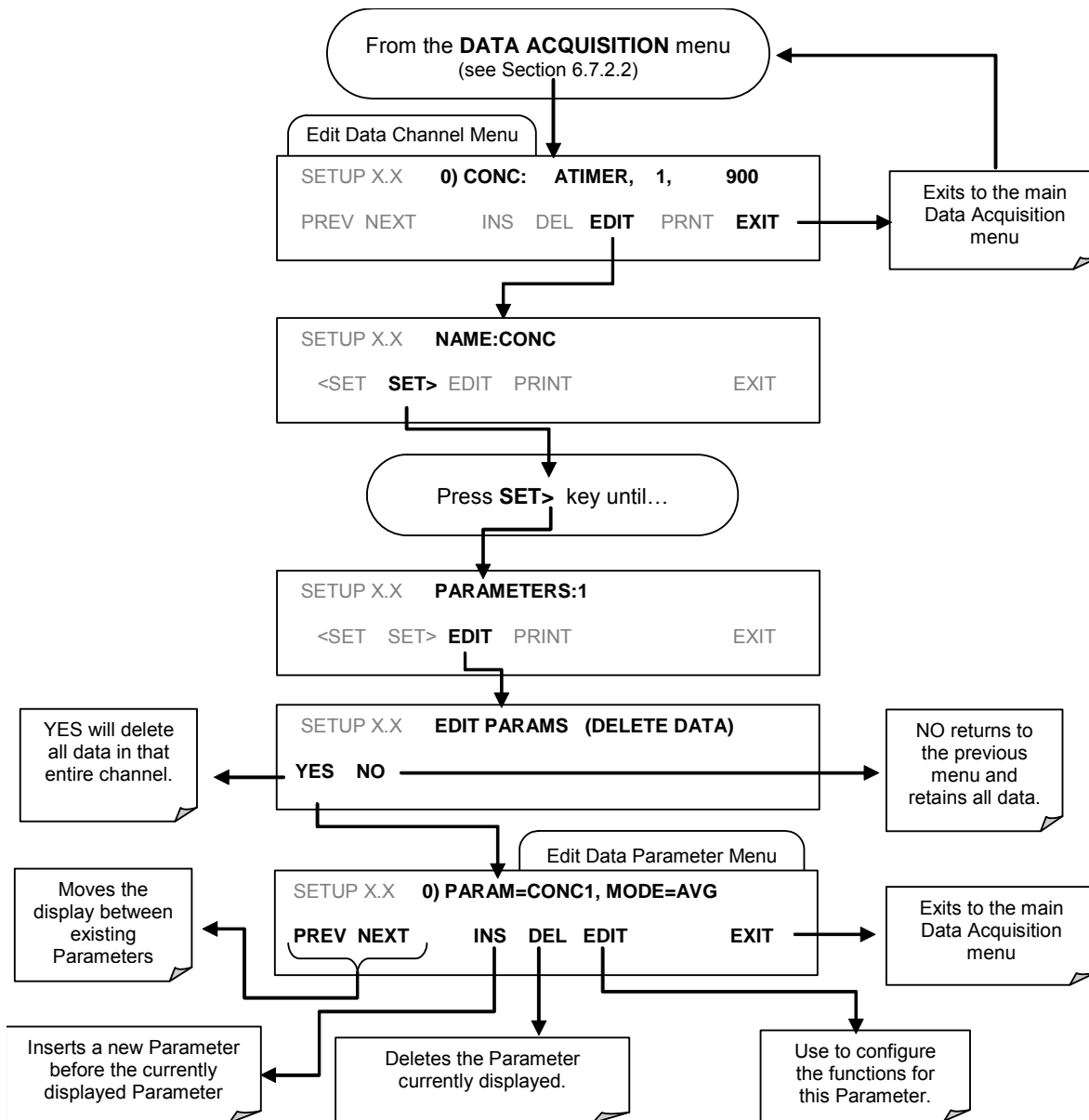

To configure a specific data parameter, press:

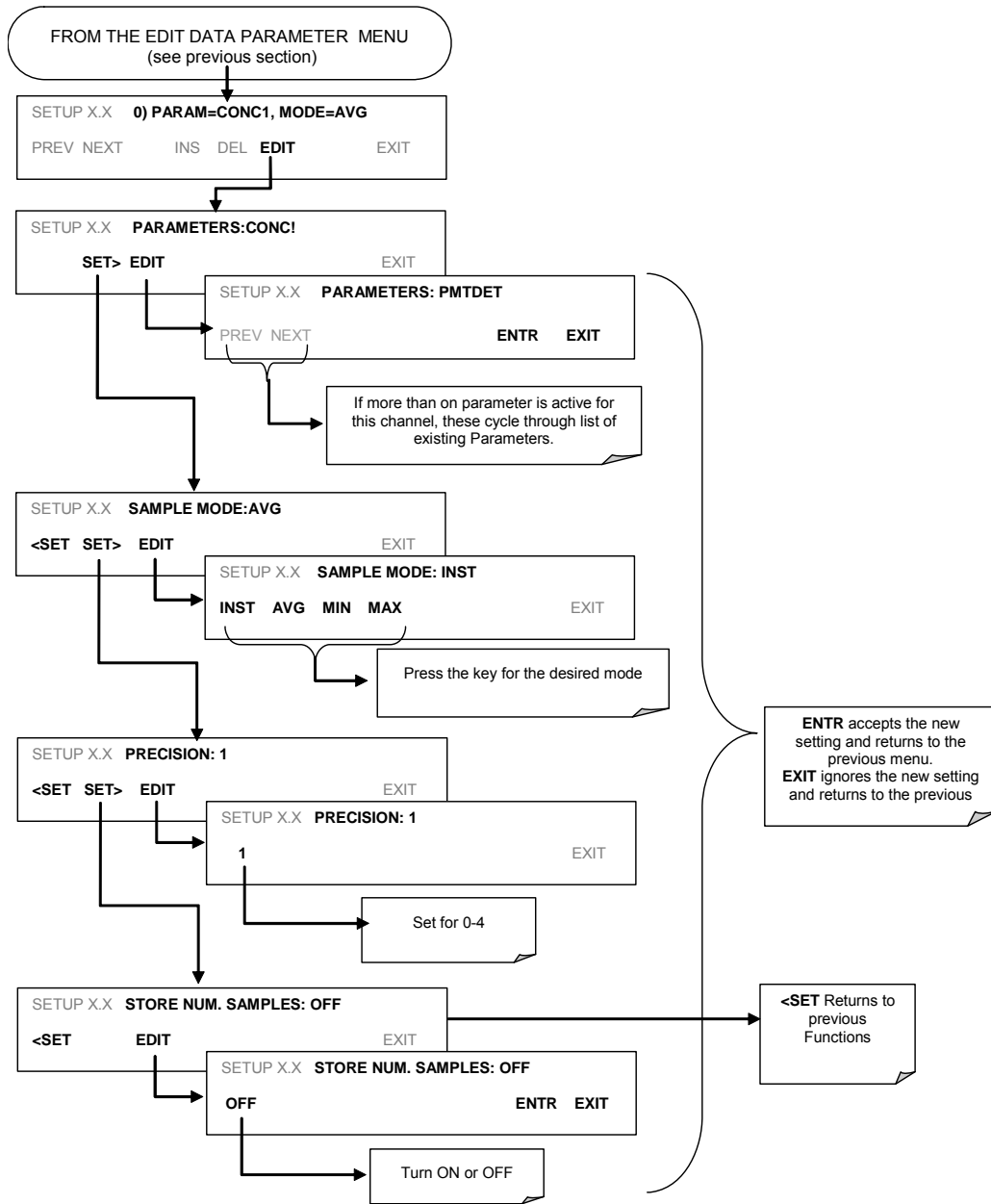

6.7.2.5. Sample Period and Report Period

The iDAS defines two principal time periods by which sample readings are taken and permanently recorded:

- **SAMPLE PERIOD:** Determines how often iDAS temporarily records a sample reading of the parameter in volatile memory. The **SAMPLE PERIOD** is set to one minute by default and generally cannot be accessed from the standard iDAS front panel menu, but is available via the instruments communication ports by using APICOM or the analyzer's standard serial data protocol.

SAMPLE PERIOD is only used when the iDAS parameter's sample mode is set for **AVG, MIN** or **MAX**.

- **REPORT PERIOD:** Sets how often the sample readings stored in volatile memory are processed, (e.g. average, minimum or maximum are calculated) and the results stored permanently in the instruments Disk-on-Chip as well as transmitted via the analyzer's communication ports. The **REPORT PERIOD** may be set from the front panel.

If the **INST** sample mode is selected the instrument stores and reports an instantaneous reading of the selected parameter at the end of the chosen **REPORT PERIOD**

In **AVG, MIN** or **MAX** sample modes, the settings for the **SAMPLE PERIOD** and the **REPORT PERIOD** determine the number of data points used each time the average, minimum or maximum is calculated, stored and reported to the COMM ports. The actual sample readings are not stored past the end of the of the chosen **REPORT PERIOD**.

Also, the **SAMPLE PERIOD** and **REPORT PERIOD** intervals are synchronized to the beginning and end of the appropriate interval of the instruments internal clock.

- If **SAMPLE PERIOD** were set for one minute the first reading would occur at the beginning of the next full minute according to the instrument's internal clock.
- If the **REPORT PERIOD** were set for of one hour the first report activity would occur at the beginning of the next full hour according to the instrument's internal clock.

EXAMPLE: Given the above settings, if iDAS were activated at 7:57:35 the first sample would occur at 7:58 and the first report would be calculated at 8:00 consisting of data points for 7:58. 7:59 and 8:00.

During the next hour (from 8:01 to 9:00) the instrument will take a sample reading every minute and include 60 sample readings.

When the **STORE NUM. SAMPLES** feature is turned on the instrument will also store how many sample readings were used for the **AVG, MIN** or **MAX** calculation but not the readings themselves.

REPORT PERIODS IN PROGRESS WHEN INSTRUMENT IS POWERED OFF

If the instrument is powered off in the middle of a **REPORT PERIOD**, the samples accumulated so far during that period are lost. Once the instrument is turned back on, the iDAS restarts taking samples and temporarily them in volatile memory as part of the **REPORT PERIOD** currently active at the time of restart. At the end of this **REPORT PERIOD** only the sample readings taken since the instrument was turned back on will be included in any **AVG, MIN** or **MAX** calculation. Also, the **STORE NUM. SAMPLES** feature will report the number of sample readings taken since the instrument was restarted.

To define the **REPORT PERIOD**, follow the instruction shown in Section 6.7.2.2 then press:

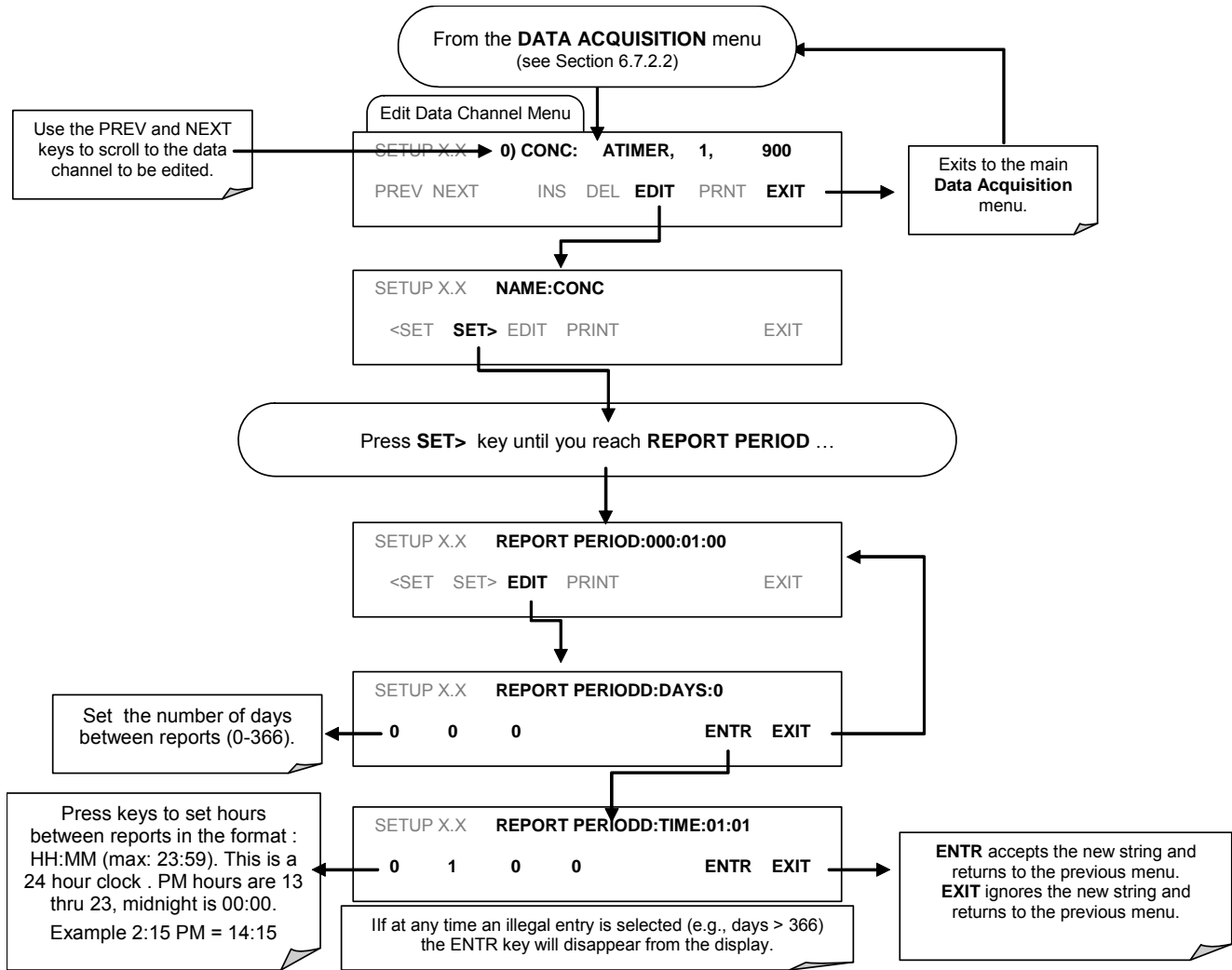

6.7.2.6. Number of Records

The number of data records in the M360E is limited to about a cumulative one million data points in all channels (one megabyte of space on the disk-on-chip). However, the actual number of records is also limited by the total number of parameters and channels and other settings in the iDAS configuration. Every additional data channel, parameter, number of samples setting etc. and will reduce the maximum amount of data points somewhat. In general, however, the maximum data capacity is divided amongst all channels (max: 20) and parameters (max: 50 per channel).

The iDAS will check the amount of available data space and prevent the user from specifying too many records at any given point. If, for example, the iDAS memory space can accommodate 375 more data records, the ENTR key will disappear when trying to specify more than that number of records. This check for memory space may also make an upload of an iDAS configuration with APICOM or a Terminal program fail, if the combined number of records would be exceeded. In this case, it is suggested to either try from the front panel what the maximum number of records can be or use trial-and-error in designing the iDAS script or calculate the number of records using the DAS or APICOM manuals. To set the number of records for one channel from the front panel, press SETUP-DAS-EDIT-ENTR and the following key sequence.

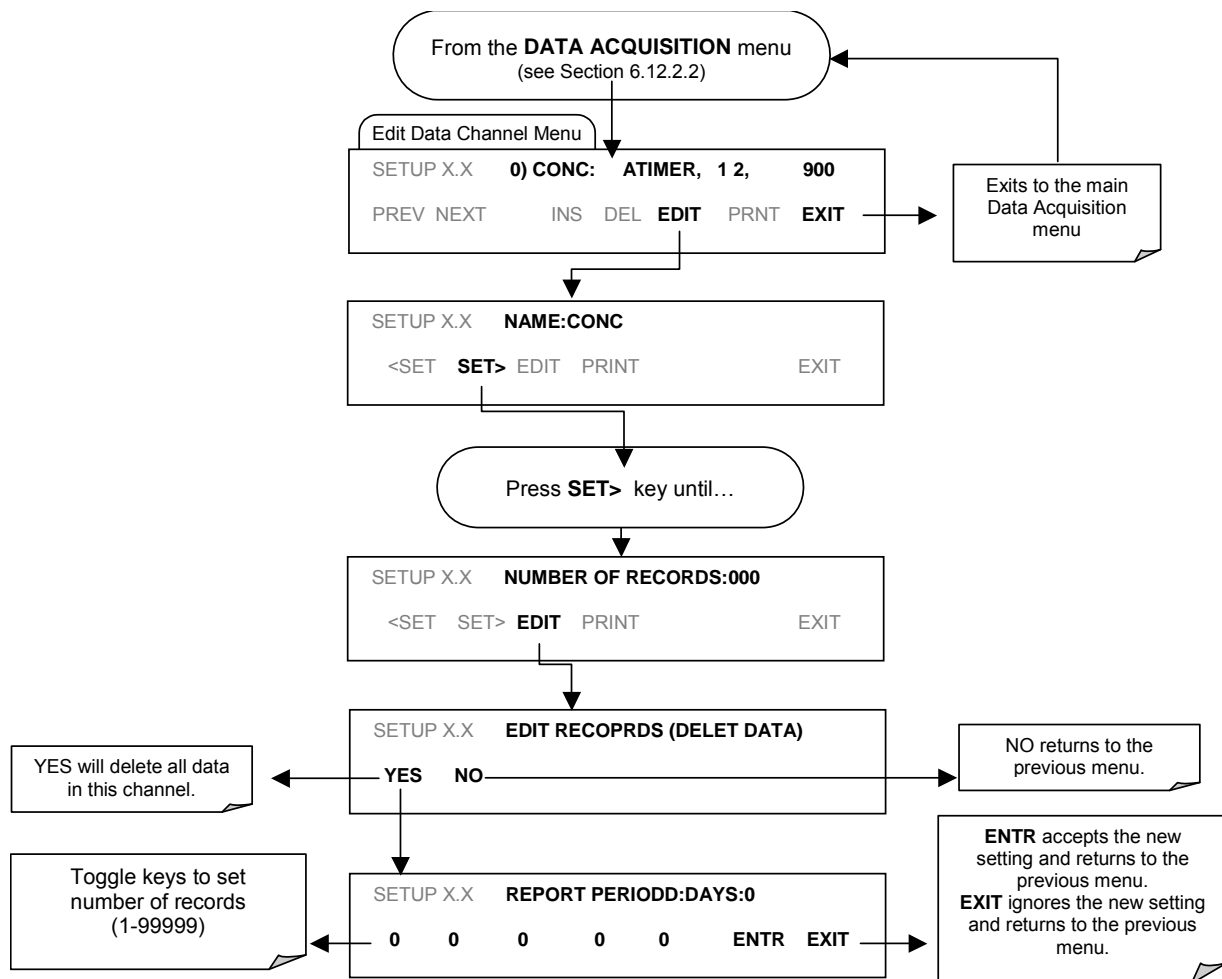

6.7.2.7. RS-232 Report Function

The M360E iDAS can automatically report data to the communications ports, where they can be captured with a terminal emulation program or simply viewed by the user.

To enable automatic COM port reporting, follow the instruction shown in Section 6.7.2.2 then press:

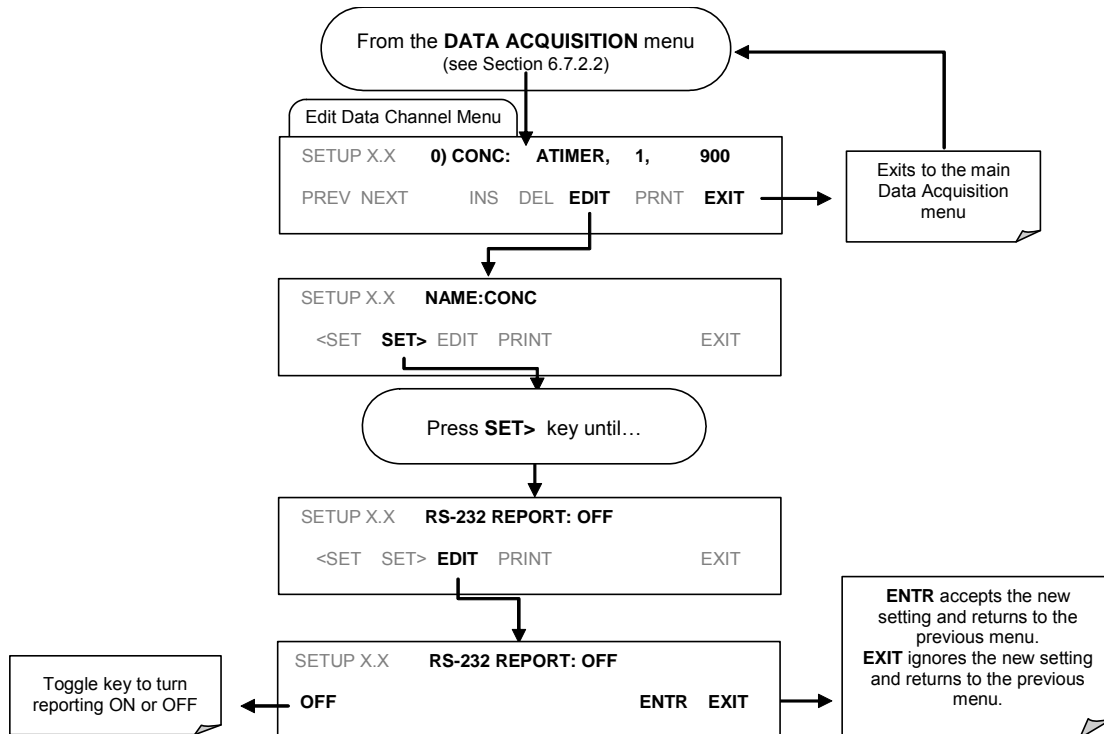

6.7.2.8. Compact Report

When enabled, this option avoids unnecessary line breaks on all RS-232 reports. Instead of reporting each parameter in one channel on a separate line, up to five parameters are reported in one line.

6.7.2.9. Starting Date

This option allows to specify a starting date for any given channel in case the user wants to start data acquisition only after a certain time and date. If the **Starting Date** is in the past, the iDAS ignores this setting.

6.7.2.10. Disabling/Enabling Data Channels

Data channels can be temporarily disabled, which can reduce the read/write wear on the disk-on-chip. The ALL_01 channel of the M360E, for example, is disabled by default.

To disable a data channel, follow the instruction shown in Section 6.7.2.2 then press:

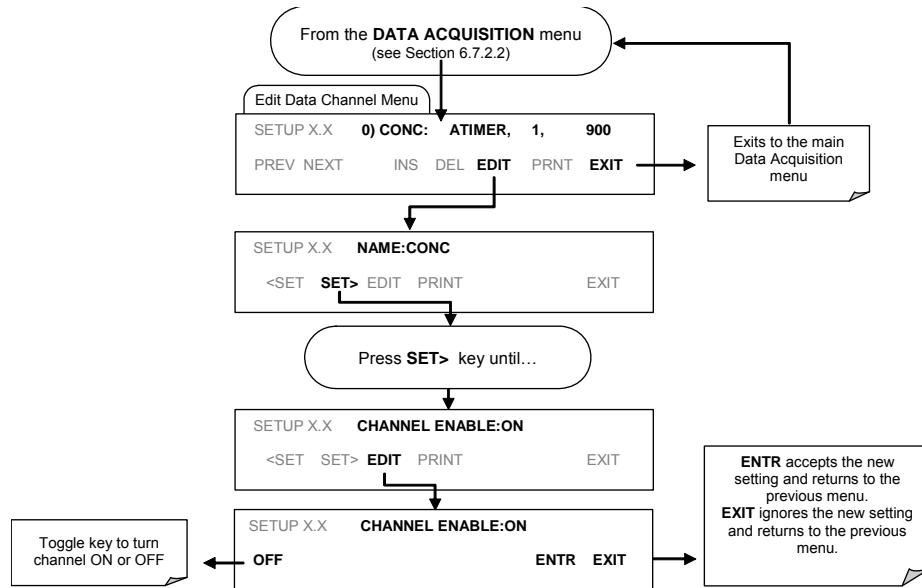

6.7.2.11. HOLDOFF Feature

The iDAS HOLDOFF feature allows to prevent data collection during calibrations and during the DAS_HOLD OFF period enabled and specified in the VARS (Section 6.12). To enable or disable the HOLDOFF, follow the instruction shown in Section 6.7.2.2 then press:

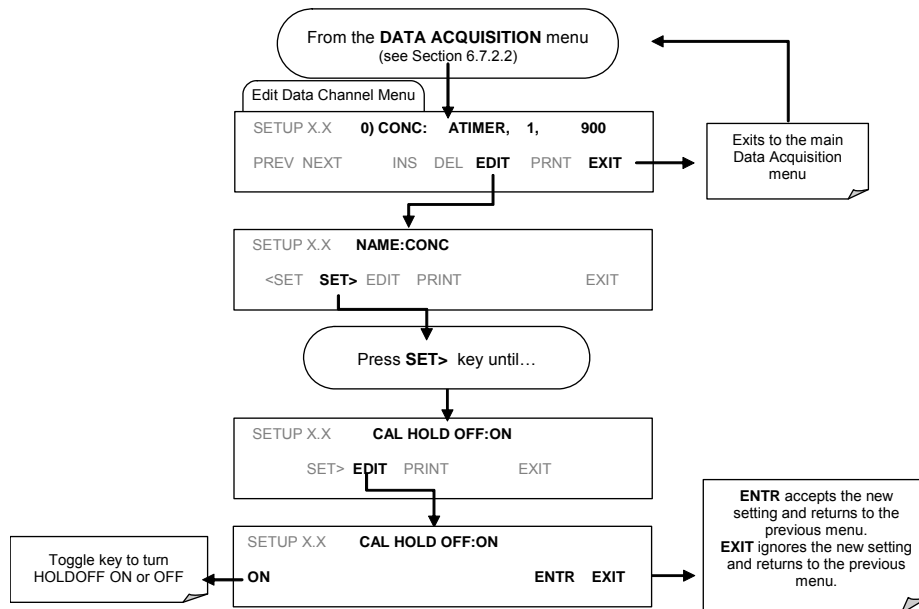

6.7.3. Remote iDAS Configuration

Editing channels, parameters and triggering events as described in this can be performed via the APICOM remote control program using the graphic interface shown in Figure 6-5. Refer to Section 6.15 for details on remote access to the M360E analyzer.

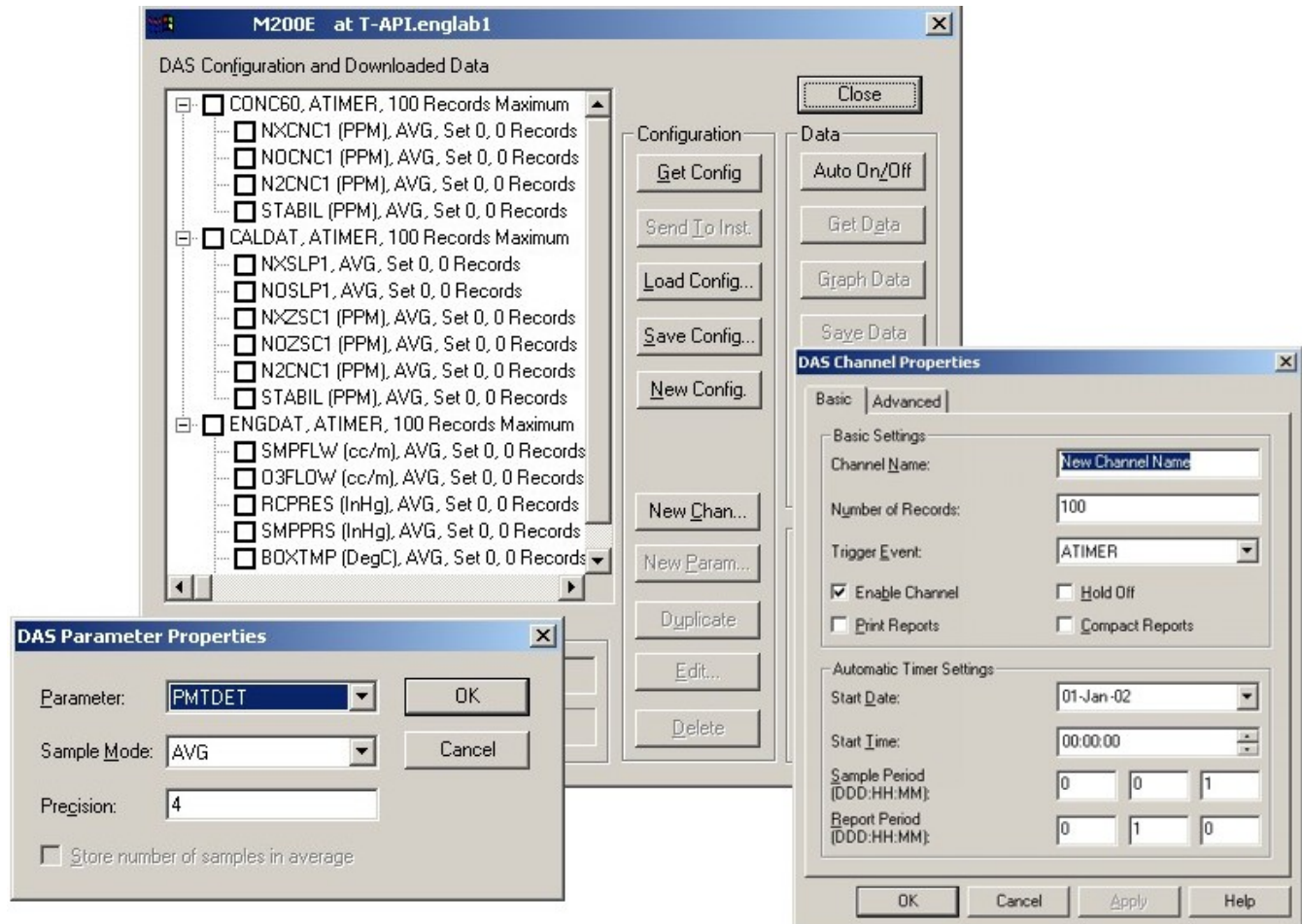
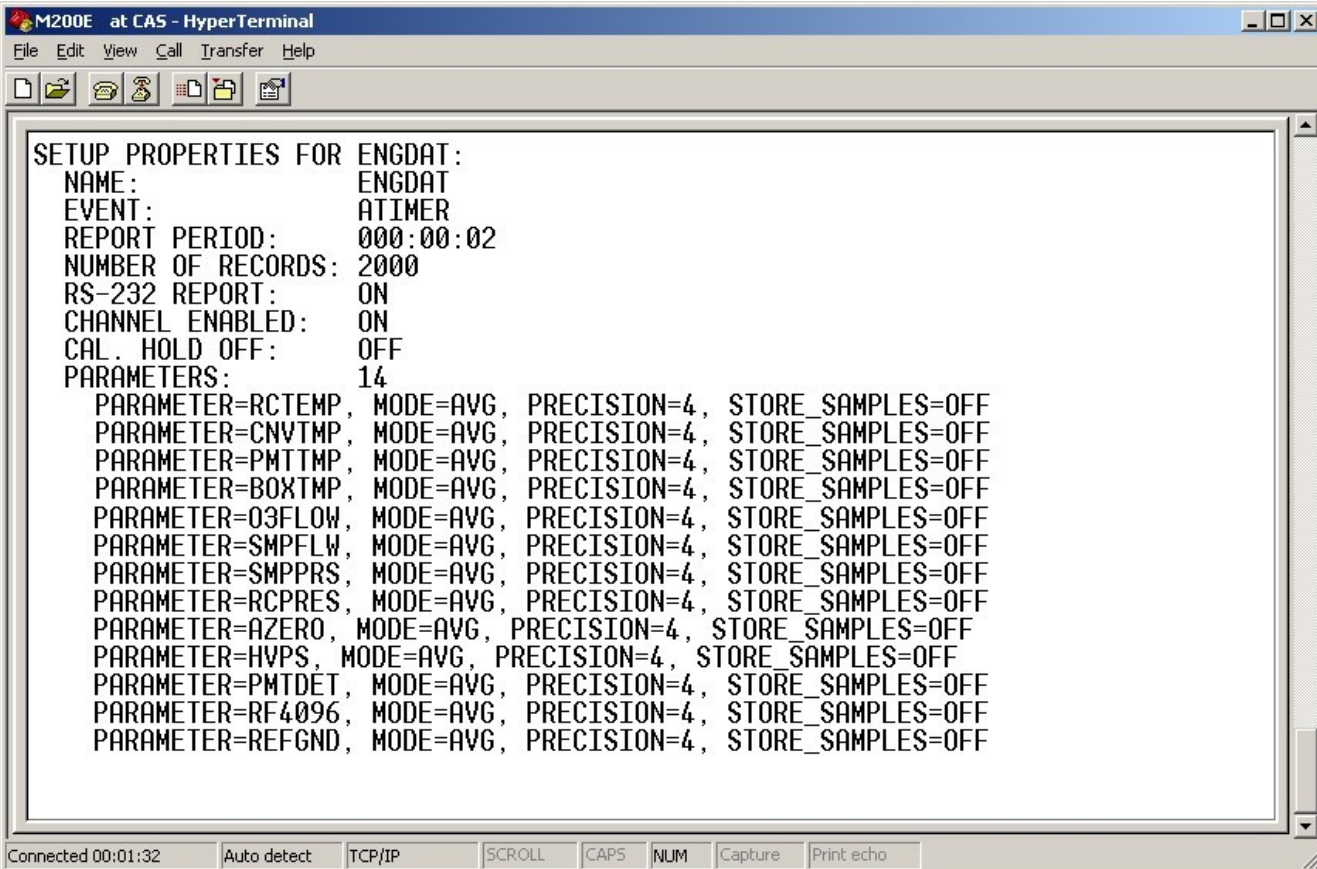

Figure 6-5: APICOM user interface for configuring the iDAS.

Once an iDAS configuration is edited (which can be done offline and without interrupting DAS data collection), it is conveniently uploaded to the instrument and can be stored on a computer for later review, alteration or documentation and archival. Refer to the APICOM manual for details on these procedures. The APICOM user manual (Teledyne Instruments part number 039450000) is included in the APICOM installation file, which can be downloaded at <http://www.teledyne-api.com/software/apicom/>.

Although Teledyne Instruments recommends the use of APICOM, the iDAS can also be accessed and configured through a terminal emulation program such as HyperTerminal (Figure 6-6). However, all configuration commands must be created following a strict syntax or be pasted in from of a text file, which was edited offline and then uploaded through a specific transfer procedure.



The screenshot shows a HyperTerminal window titled "M200E at CAS - HyperTerminal". The window displays the following configuration for channel "ENG DAT":

```
SETUP PROPERTIES FOR ENG DAT:
NAME: ENG DAT
EVENT: ATIMER
REPORT PERIOD: 000:00:02
NUMBER OF RECORDS: 2000
RS-232 REPORT: ON
CHANNEL ENABLED: ON
CAL. HOLD OFF: OFF
PARAMETERS: 14
PARAMETER=RCTEMP, MODE=AVG, PRECISION=4, STORE_SAMPLES=OFF
PARAMETER=CNVTMP, MODE=AVG, PRECISION=4, STORE_SAMPLES=OFF
PARAMETER=PMTTMP, MODE=AVG, PRECISION=4, STORE_SAMPLES=OFF
PARAMETER=BOXTMP, MODE=AVG, PRECISION=4, STORE_SAMPLES=OFF
PARAMETER=O3FLOW, MODE=AVG, PRECISION=4, STORE_SAMPLES=OFF
PARAMETER=SMPFLW, MODE=AVG, PRECISION=4, STORE_SAMPLES=OFF
PARAMETER=SMPPRS, MODE=AVG, PRECISION=4, STORE_SAMPLES=OFF
PARAMETER=RCPRES, MODE=AVG, PRECISION=4, STORE_SAMPLES=OFF
PARAMETER=AZERO, MODE=AVG, PRECISION=4, STORE_SAMPLES=OFF
PARAMETER=HVPS, MODE=AVG, PRECISION=4, STORE_SAMPLES=OFF
PARAMETER=PMTDET, MODE=AVG, PRECISION=4, STORE_SAMPLES=OFF
PARAMETER=RF4096, MODE=AVG, PRECISION=4, STORE_SAMPLES=OFF
PARAMETER=REFGND, MODE=AVG, PRECISION=4, STORE_SAMPLES=OFF
```

The status bar at the bottom of the window shows "Connected 00:01:32" and several control buttons: "Auto detect", "TCP/IP", "SCROLL", "CAPS", "NUM", "Capture", and "Print echo".

Figure 6-6: iDAS Configuration Through a Terminal Emulation Program.

Both procedures are best started by downloading the default iDAS configuration, getting familiar with its command structure and syntax conventions, and then altering a copy of the original file offline before uploading the new configuration.

CAUTION

Whereas the editing, adding and deleting of iDAS channels and parameters of one channel through the front-panel keyboard can be done without affecting the other channels, uploading an iDAS configuration script to the analyzer through its communication ports will erase all data, parameters and channels by replacing them with the new iDAS configuration. Backup of data and the original iDAS configuration is advised before attempting any iDAS changes.

6.8. SETUP → RNGE: Analog Output Reporting Range Configuration

The analyzer has three active analog output signals, accessible through a connector on the rear panel.

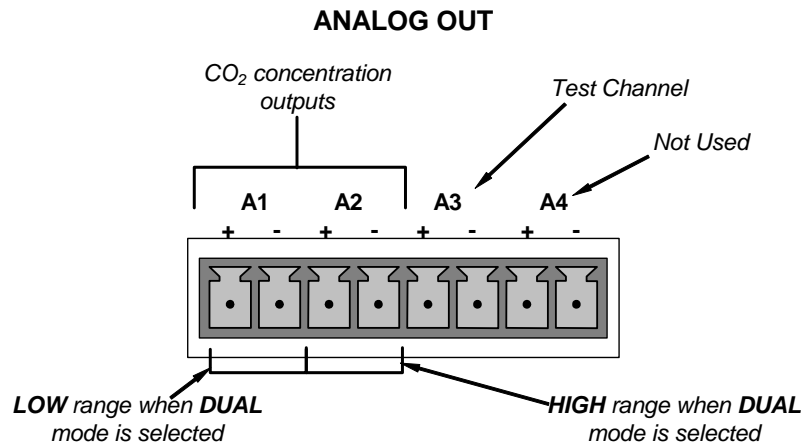

Figure 6-7: Analog Output Connector Pin Out

All three outputs can be configured either at the factory or by the user for full scale outputs of 0.1 VDC, 1VDC, 5VDC or 10VDC. Additionally **A1** and **A2** may be equipped with optional 0-20 mADC current loop drivers and configured for any current output within that range (e.g. 0-20, 2-20, 4-20, etc.). The user may also adjust the signal level and scaling of the actual output voltage or current to match the input requirements of the recorder or data logger (See Section 6.13.4).

The **A1** and **A2** channels output a signal that is proportional to the CO₂ concentration of the sample gas. Several modes are available which allow them to operate independently or be slaved together (See Section 6.7). The user may also select between a variety of reporting range spans (See Sections 6.8.3, 6.8.4 and 6.8.5).

EXAMPLE:

A1 OUTPUT: Output Signal = 0-5 VDC representing 0-1000 ppm concentration values

A2 OUTPUT: Output Signal = 0 – 10 VDC representing 0-500 ppm concentration values.

Output **A3** is only active if the O₂ sensor option is installed. In this case a signal representing the currently measured O₂ concentration is output on this channel.

The output, labeled **A4** is special. It can be set by the user (See Section 6.13.9) to output several of the test functions accessible through the <TST TST> keys of the units sample display.

6.8.1. Physical Range versus Analog Output Reporting Ranges

Functionally, the Model 360E Gas Filter Correlation CO₂ Analyzer has one hardware Physical Range that is capable of determining CO₂ concentrations between 50 ppb and 2,000 ppm. This architecture improves reliability and accuracy by avoiding the need for extra, switchable, gain-amplification circuitry. Once properly calibrated, the analyzer's front panel will accurately report concentrations along the entire span of its 50 ppb and 2,000 ppm physical range.

Because, most applications use only a small part of the analyzer's physical range, the width of the Model 360E's physical range can create data resolution problems for most analog recording devices. For example, in an application where the expected concentration of CO₂ is typically less than 500 ppm, the full scale of expected values is only 25% of the instrument's 2,000 ppm physical range. Unmodified, the corresponding output signal would also be recorded across only 25% of the range of the recording device.

The M360E solves this problem by allowing the user to select a scaled reporting range for the analog outputs that only includes that portion of the physical range relevant to the specific application. Only the reporting range of the analog outputs is scaled, the physical range of the analyzer and the readings displayed on the front panel remain unaltered.

6.8.2. Reporting Range Modes

The M360E provides three analog output range modes to choose from.

- Single range (**SNGL**) mode sets a single maximum range for the analog output. If single range is selected (See Section 6.78.3) both outputs are slaved together and will represent the same measurement span (e.g. 0-50 ppm), however their electronic signal levels may be configured for different ranges (e.g. 0-10 VDC vs. 0-.1 VDC – See Section 6.9.4.1).

Dual range (**DUAL**) allows the A1 and A2 outputs to be configured with different measurement spans (See Section 6.8.4) as well as separate electronic signal levels (See Section 6.9.4.1).

- Auto range (**AUTO**) mode gives the analyzer the ability to output data via a low range and high range. When this mode is selected (See Section 6.8.5) the M360E will automatically switch between the two ranges dynamically as the concentration value fluctuates.

Range status is also output via the external digital I/O status outputs (See Section 6.15.1.1).

To select the Analog Output Range Type press:

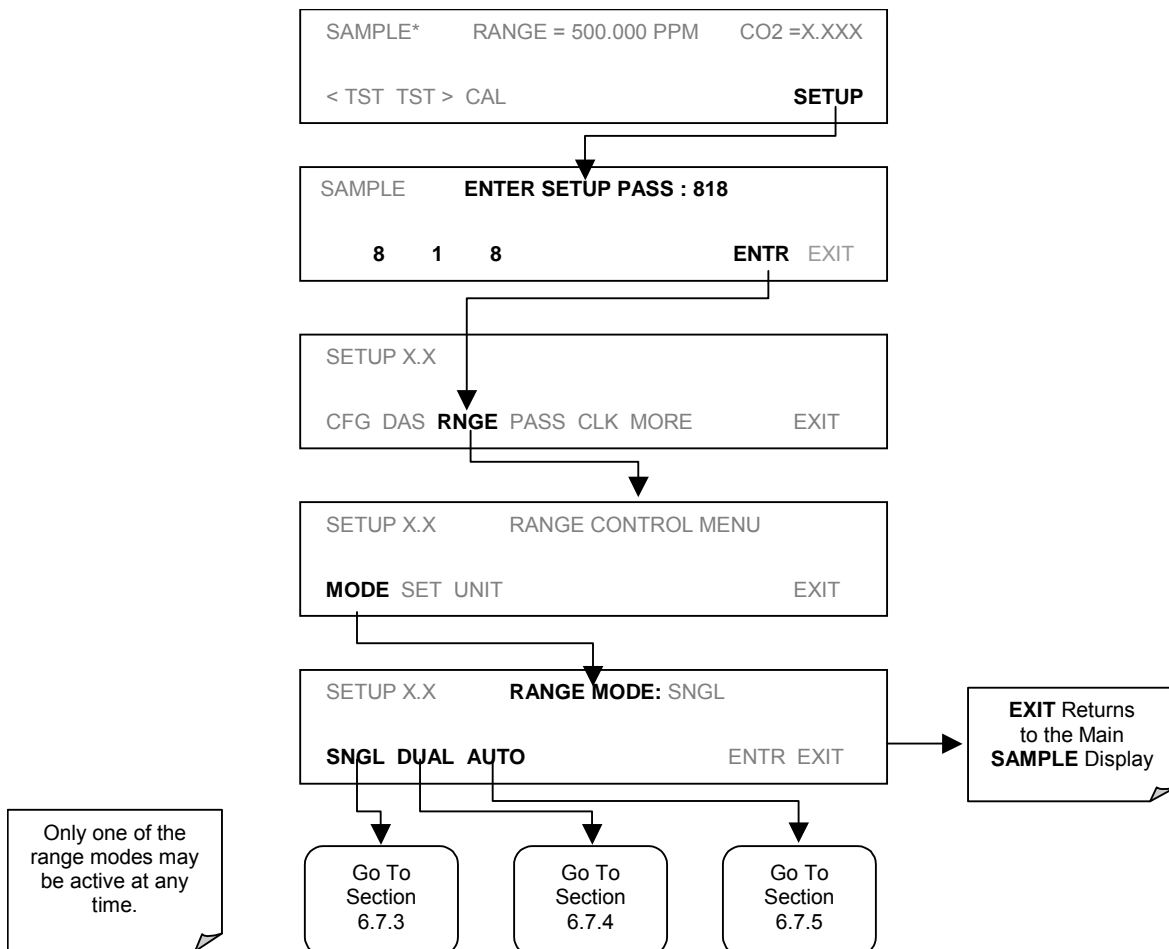

NOTE

Upper span limit setting for the individual range modes are shared. Resetting the span limit in one mode also resets the span limit for the corresponding range in the other modes as follows:



6.8.3. Single Range mode (SNGL)

This is the default reporting range mode for the analyzer. In single range mode both **A1** and **A2** are set to the same reporting range. This reporting range can be any value between 50 ppb and 2 000 ppm.

While the two outputs always have the same reporting range, the span, signal offset and scaling of their electronic signals may be configured for differently (e.g., **A1** = 0-10 V; **A2** = 0-0.1 V). See Section 6.13.4 for instructions on adjusting these parameters.

To select **SNGL** range mode and to set the upper limit of the range, press:

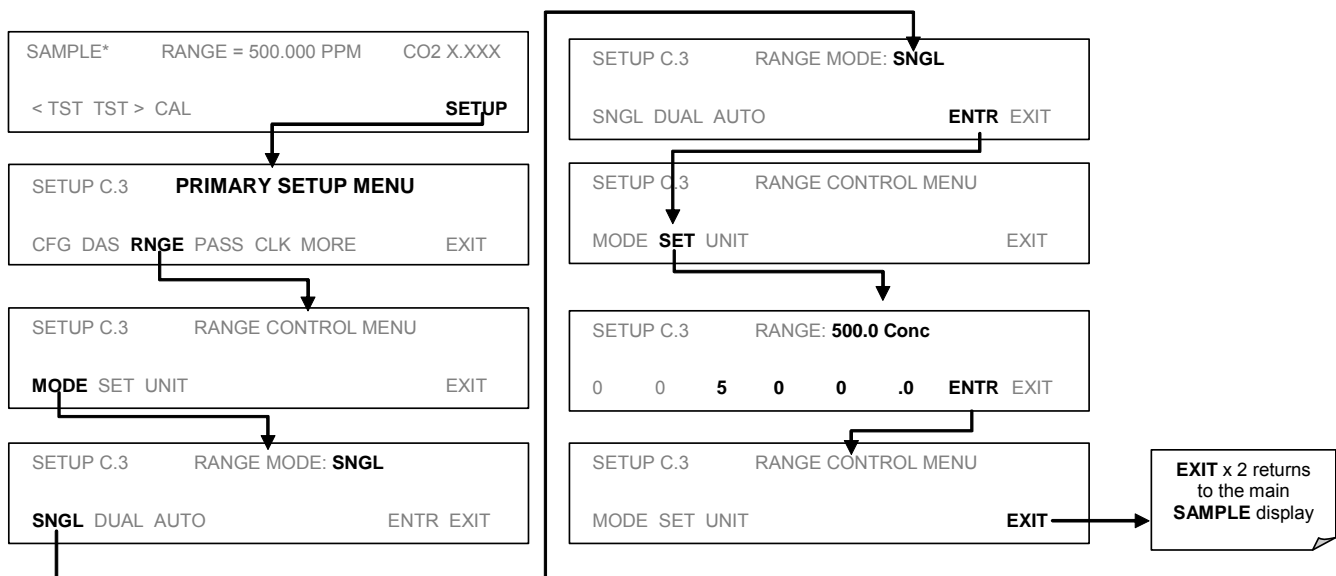

6.8.4. Dual Range Mode (DUAL)

Selecting Dual Range mode allows the **A1** and **A2** outputs to be configured with different reporting ranges. The analyzer software calls these two ranges low and high. The low range setting corresponds with the analog output labeled **A1** on the Rear Panel of the instrument. The high Range Setting corresponds with the **A2** output. While the software names these two ranges low and high, they do not have to be configured that way. For example: The low range can be set for a span of 0-1000 ppm while the high range is set for 0-500 ppm.

In **DUAL** range mode the **RANGE** test function displayed on the front panel will be replaced by two separate functions:

- **RANGE1**: The range setting for the **A1** output.
- **RANGE2**: The range setting for the **A2** output.

To set the ranges press following keystroke sequence

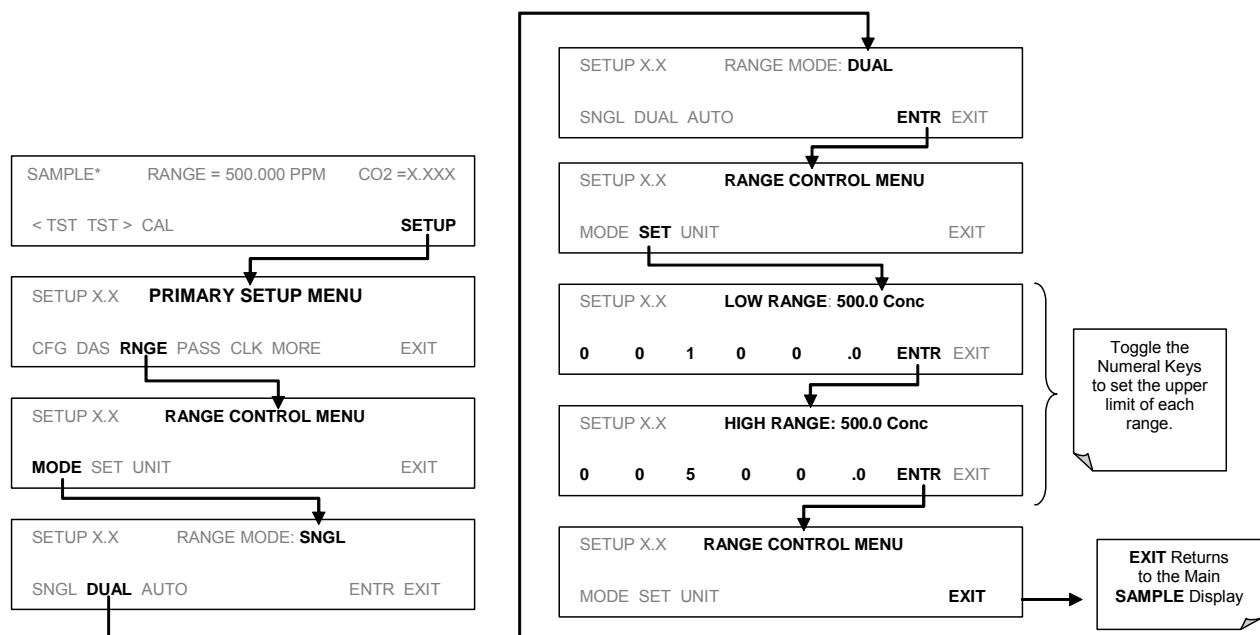

When the instrument's range mode is set to **DUAL** the concentration field in the upper right hand corner of the display alternates between displaying the low range value and the high range value. The concentration currently being displayed is identified as follows: C1 = Low (or **A1**) and C2 = High (or **A2**).

NOTE

In DUAL range mode the LOW and HIGH ranges have separate slopes and offsets for computing CO₂ concentration.

The two ranges must be independently calibrated.

6.8.5. Auto Range Mode (AUTO)

In **AUTO** range mode, the analyzer automatically switches the reporting range between two user-defined ranges (low and high). The unit will switch from low range to high range when the CO₂ concentration exceeds 98% of the low range span. The unit will return from high range back to low range once both the CO₂ concentration falls below 75% of the low range span.

In **AUTO** Range mode the instrument reports the same data in the same range on both the **A1** and **A2** outputs and automatically switches both outputs between ranges as described above. Also, the **RANGE** test function displayed on the front panel will automatically switch to show which range is in effect.

The high/low range status is also reported through the external, digital status outputs (Section 6.15.1.1).

To set individual ranges press the following keystroke sequence.

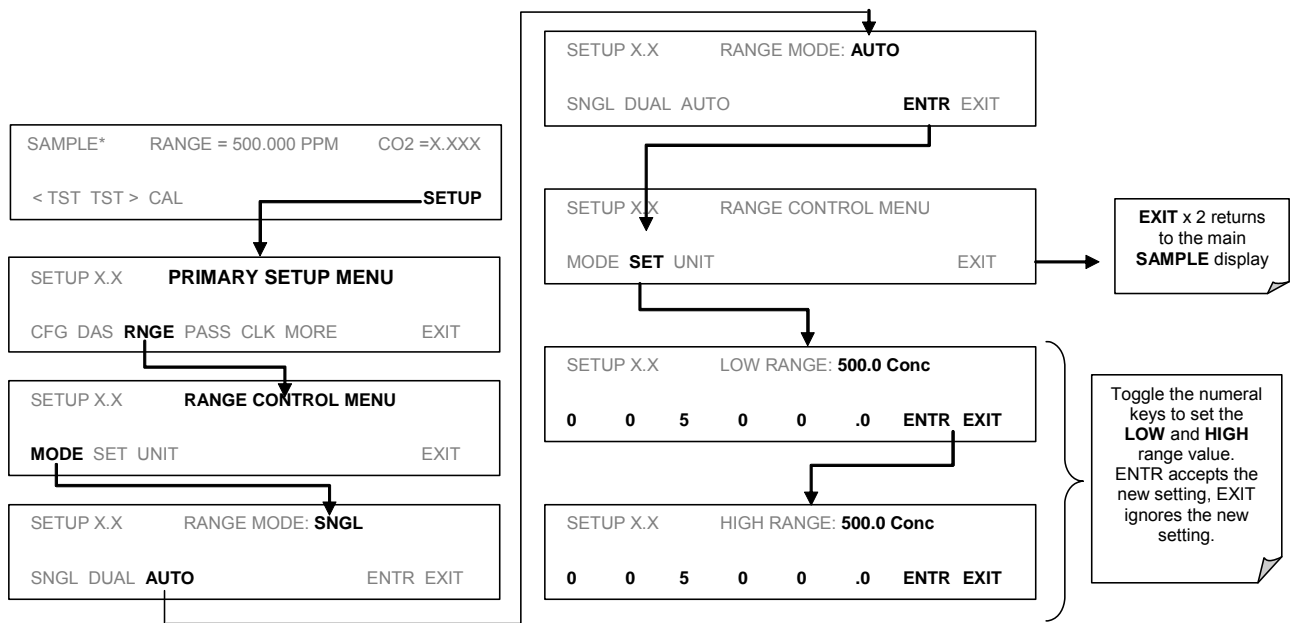

CAUTION

In AUTO range mode the LOW and HIGH ranges have separate slopes and offsets for computing CO₂ concentration.

The two ranges must be independently calibrated.

NOTE

Avoid accidentally setting the low range of the instrument with a higher span limit than the high range. This will cause the unit to stay in the low reporting range perpetually and defeat the function of the AUTO range mode.

6.8.6. Range Units

The M360E can display concentrations in parts per billion (10^9 mols per mol, **PPB**), parts per million (10^6 mols per mol, **PPM**), micrograms per cubic meter ($\mu\text{g}/\text{m}^3$, **UG**), milligrams per cubic meter (mg/m^3 , **MG**) or percent (volume CO_2 /volume sample gas, %). Changing units affects all of the display, analog outputs, COM port and iDAS values for all reporting ranges regardless of the analyzer's range mode.

NOTE

Concentrations displayed in mg/m^3 and $\mu\text{g}/\text{m}^3$ use 0°C , 760 mmHg for Standard Temperature and Pressure (STP). Consult your local regulations for the STP used by your agency.

Conversion factors from volumetric to mass units are:
 CO_2 : $\text{ppb} \times 1.96 = \mu\text{g}/\text{m}^3$; $\text{ppm} \times 1.96 = \text{mg}/\text{m}^3$

To change the concentration units:

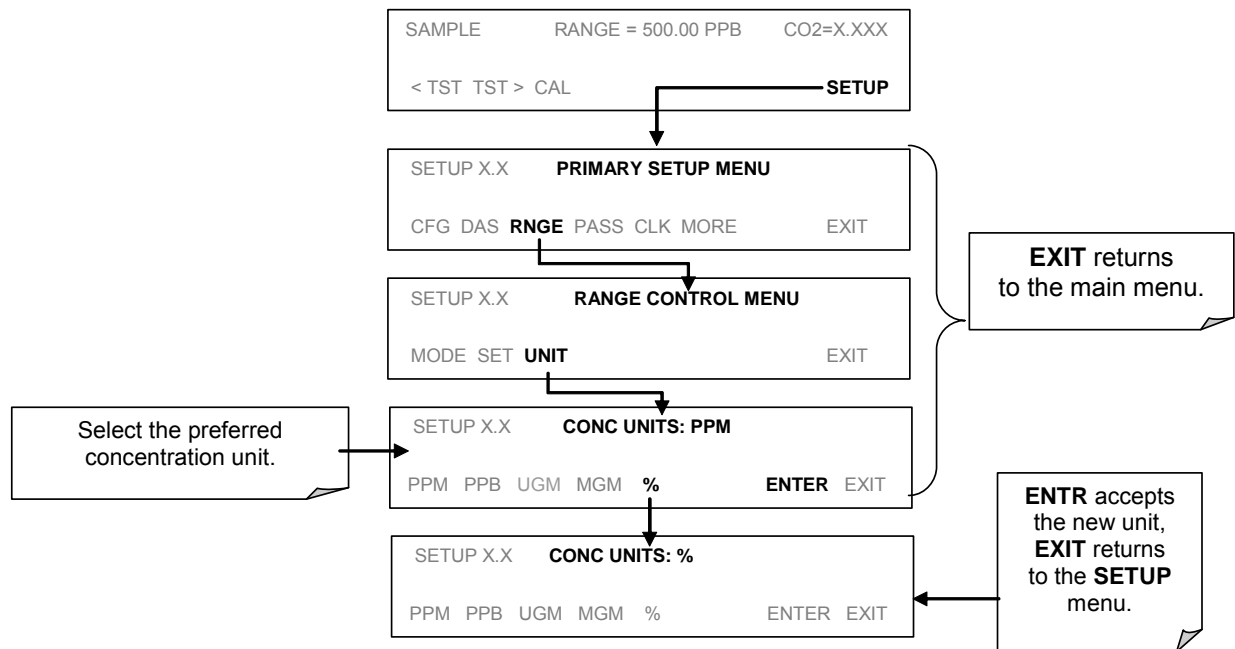

NOTE

Once the units of measurement have been changed the unit MUST be recalibrated, as the "expected span values" previously in effect will no longer be valid. Simply entering new expected span values without running the entire calibration routine is not sufficient.

6.8.7. Dilution Ratio

The dilution ratio is a software option that allows the user to compensate for any dilution of the sample gas before it enters the sample inlet. Using the dilution ratio option is a 4-step process:

1. Select reporting range units: Follow the procedure in Section 6.8.6.
2. Select the range: Use the procedures in Sections 6.8.2 – 6.8.5. Make sure that the **SPAN** value entered is the maximum expected concentration of the undiluted calibration gas and that the span gas is either supplied through the same dilution inlet system as the sample gas or has an appropriately lower actual concentration. For example, with a dilution set to 100, a 10 ppm gas can be used to calibrate a 1000 ppm sample gas if the span gas is not routed through the dilution system. On the other hand, if a 1000 ppm span gas is used, it needs to pass through the same dilution steps as the sample gas.
3. Set the dilution factor as a gain (e.g., a value of 20 means 20 parts diluting gas and 1 part of sample gas):

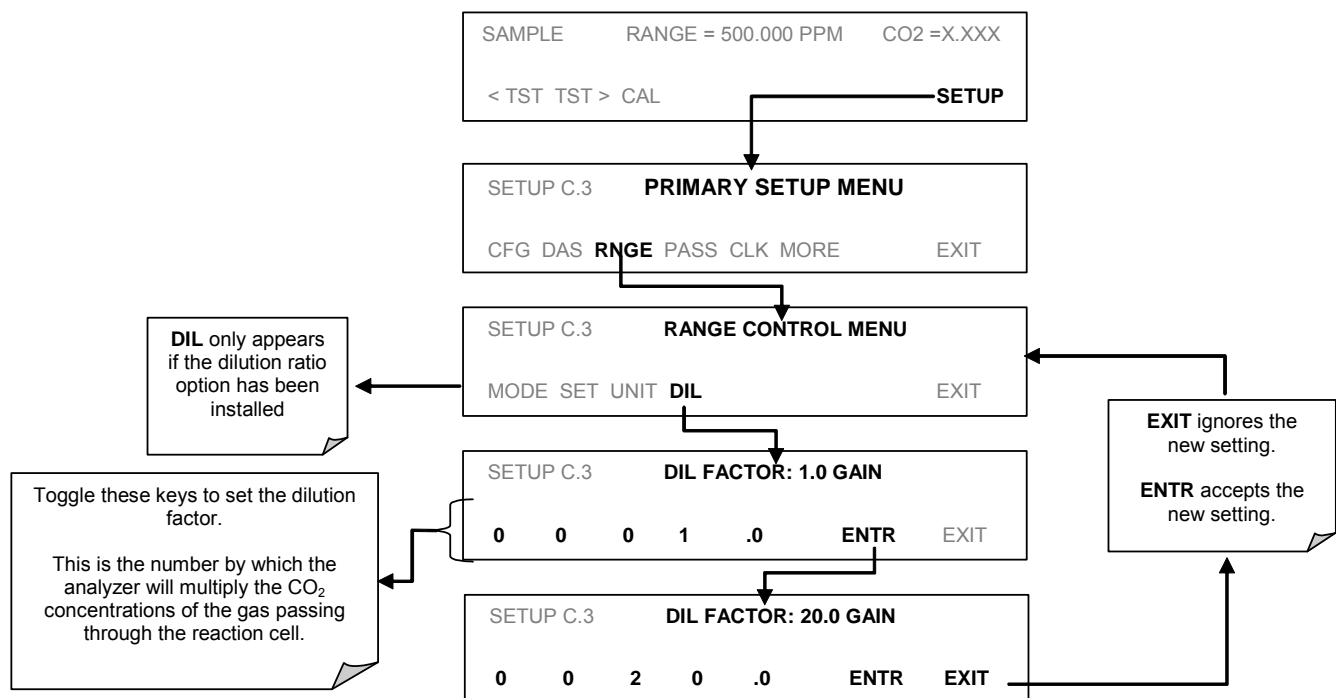

The analyzer multiplies the measured gas concentrations with this dilution factor and displays the result.

NOTE

Once the above settings have been entered, the instrument needs to be recalibrated using one of the methods discussed in Chapter 7.

6.9. SETUP → PASS: Password Feature

The M360E provides password protection of the calibration and setup functions to prevent unauthorized adjustments. When the passwords have been enabled in the **PASS** menu item, the system will prompt the user for a password anytime a password-protected function is requested.

There are three levels of password protection, which correspond to operator, maintenance, and configuration functions. Each level allows access to all of the functions in the previous level.

Table 6-9: Password Levels

PASSWORD	LEVEL	MENU ACCESS ALLOWED
No password	Operator	TEST, MSG, CLR
101	Maintenance	CAL, CALZ, CALS
818	Configuration	SETUP, VARS, DIAG

To enable or disable passwords, press the following keystroke sequence:

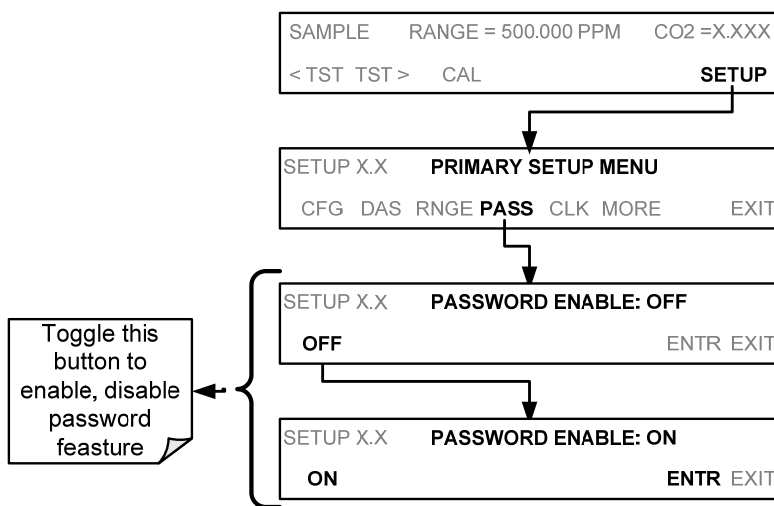

Example: If all passwords are enabled, the following keypad sequence would be required to enter the SETUP menu:

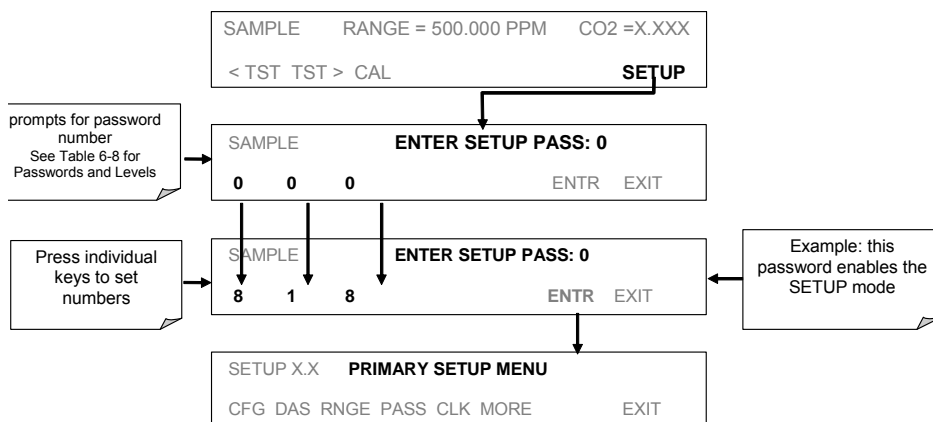

Note that the instrument still prompts for a password when entering the VARS and DIAG menus, even if passwords are disabled, but it displays the default password (818) upon entering these menus. The user only has to press ENTR to access the password-protected menus but does not have to enter the required number code.

6.10. SETUP → CLK: Setting the Internal Time-of-Day Clock

The M360E has a time of day clock that supports the AutoCal timer, time of day TEST function, and time stamps on most COM port messages. To set the time-of-day, press:

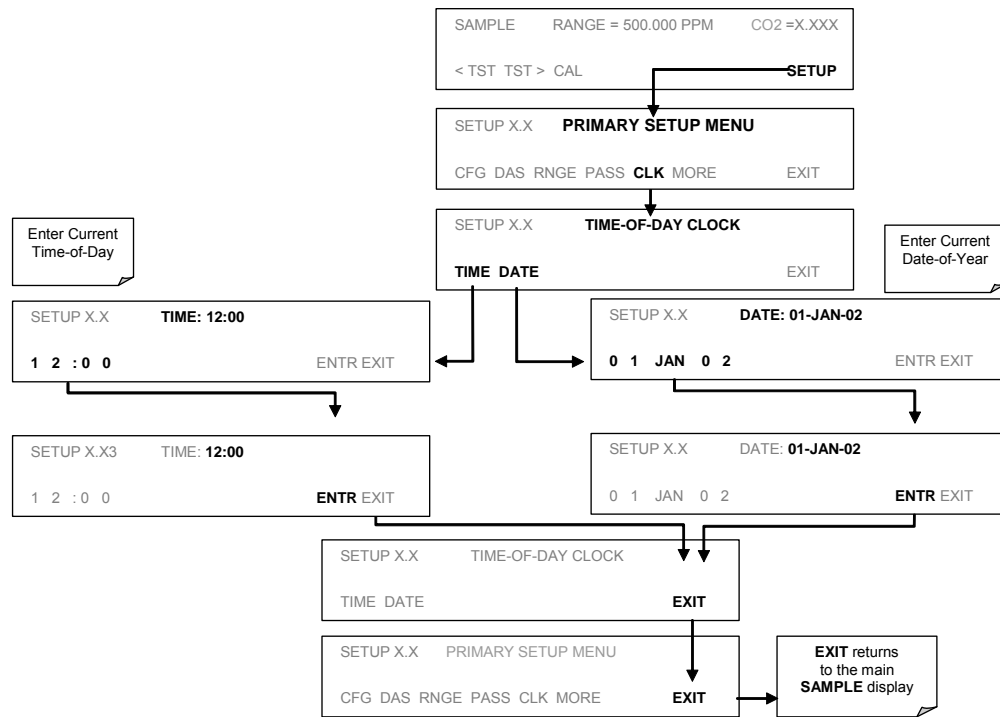

In order to compensate for CPU clocks which run faster or slower, you can adjust a variable called **CLOCK_ADJ** to speed up or slow down the clock by a fixed amount every day. To change this variable, press:

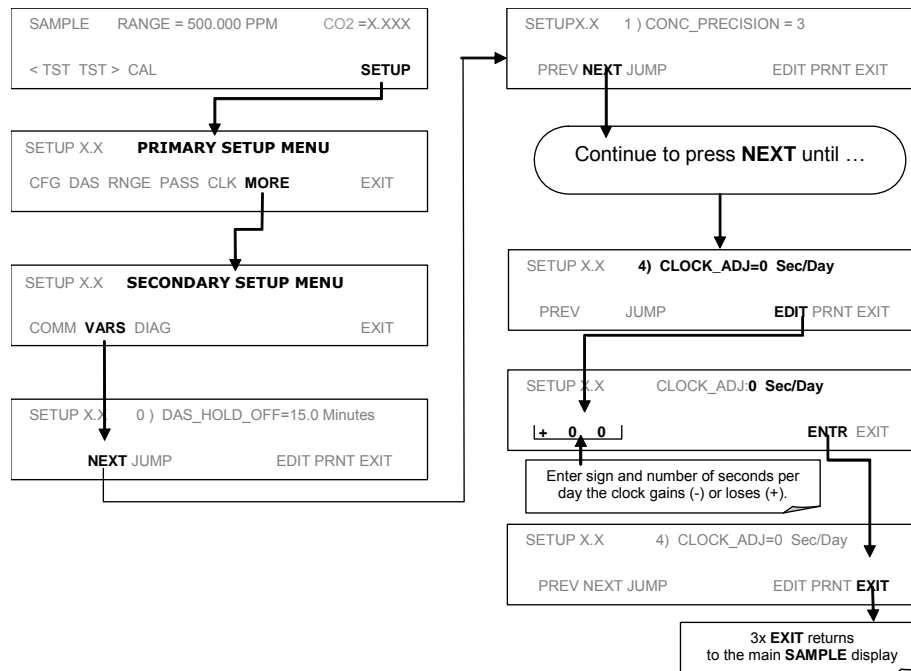

6.11. SETUP → MORE → COMM: Using the Analyser's Communication Ports

The M360E is equipped with two serial communication ports located on the rear panel (Figure 3-2). Both ports operate similarly and give the user the ability to communicate with, issue commands to, and receive data from the analyzer through an external computer system or terminal. By default, both ports operate on the RS-232 protocol.

- The COM1 port can also be configured to operate in single or RS-232 multidrop mode (option 62; See Section 5.5.2 and 6.11.7).
- The COM2 port can be configured for standard RS-232 operation, half-duplex RS-485 communication or for access via an LAN by installing the Teledyne Instruments Ethernet interface card (option 63; See Section 5.5.3 and 6.11.6).

A code-activated switch (CAS), can also be used on either port to connect typically between 2 and 16 send/receive instruments (host computer(s) printers, data loggers, analyzers, monitors, calibrators, etc.) into one communications hub. Contact Teledyne Instruments sales for more information on CAS systems.

6.11.1. Analyzer ID

Each type of Teledyne Instruments analyzer is configured with a default ID code. The default ID code for all M360M analyzers is **360**. The ID number is only important if more than one analyzer is connected to the same communications channel such as when several analyzers are on the same Ethernet LAN (See Section 6.11.6); in a RS-232 multidrop chain (See Section 6.11.7) or operating over a RS-485 network (See Section 6.11.3). If two analyzers of the same model type are used on one channel, the ID codes of one or both of the instruments needs to be changed so

To edit the instrument's ID code, press:

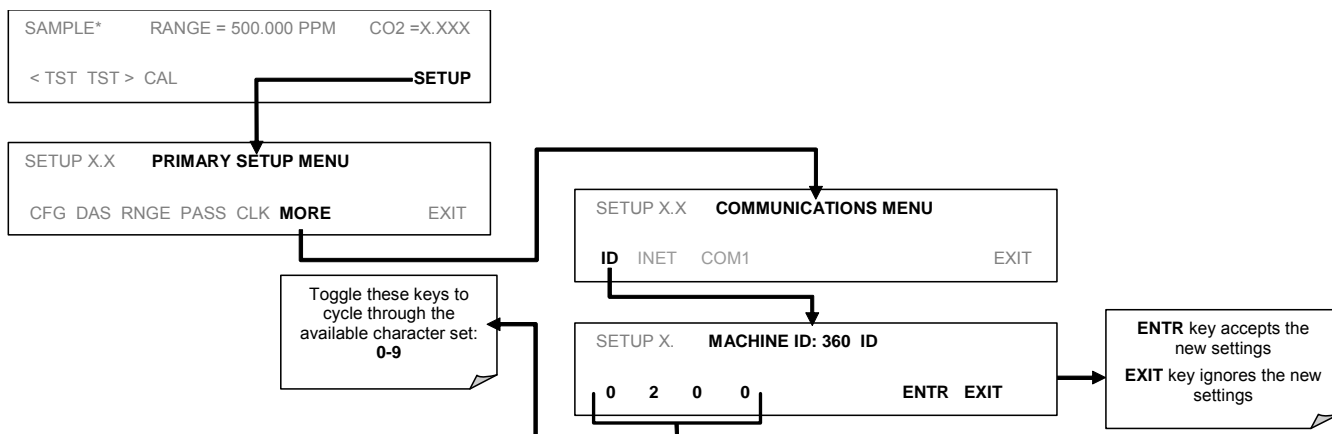

The ID number is only important if more than one analyzer is connected to the same communications channel (e.g., a multi-drop setup). Different models of Teledyne Instruments analyzers have different default ID numbers, but if two analyzers of the same model type are used on one channel (for example, two M360E's), the ID of one instrument needs to be changed.

The ID can also be used for to identify any one of several analyzers attached to the same network but situated in different physical locations.

6.11.2. COMM Port Default Settings

Received from the factory, the analyzer is set up to emulate a DCE or modem, with pin 3 of the DB-9 connector designated for receiving data and pin 2 designated for sending data.

- **COM1:** RS-232 (fixed) DB-9 male connector.
 - **Baud rate:** 19200 bits per second (baud).
 - **Data Bits:** 8 data bits with 1 stop bit.
 - **Parity:** None.
- **COM2:** RS-232 (configurable), DB-9 female connector.
 - **Baud rate:** 115000 bits per second (baud).
 - **Data Bits:** 8 data bits with 1 stop bit.
 - **Parity:** None.

NOTE

Cables that appear to be compatible because of matching connectors may incorporate internal wiring that make the link inoperable. Check cables acquired from sources other than Teledyne Instruments for pin assignments before using.

In its default configuration, the M360E analyzer has two available RS-232 Com ports accessible via 2 DB-9 connectors on the back panel of the instrument. The COM1 connector is a male DB-9 connector and the COM2 is a female DB9 connector.

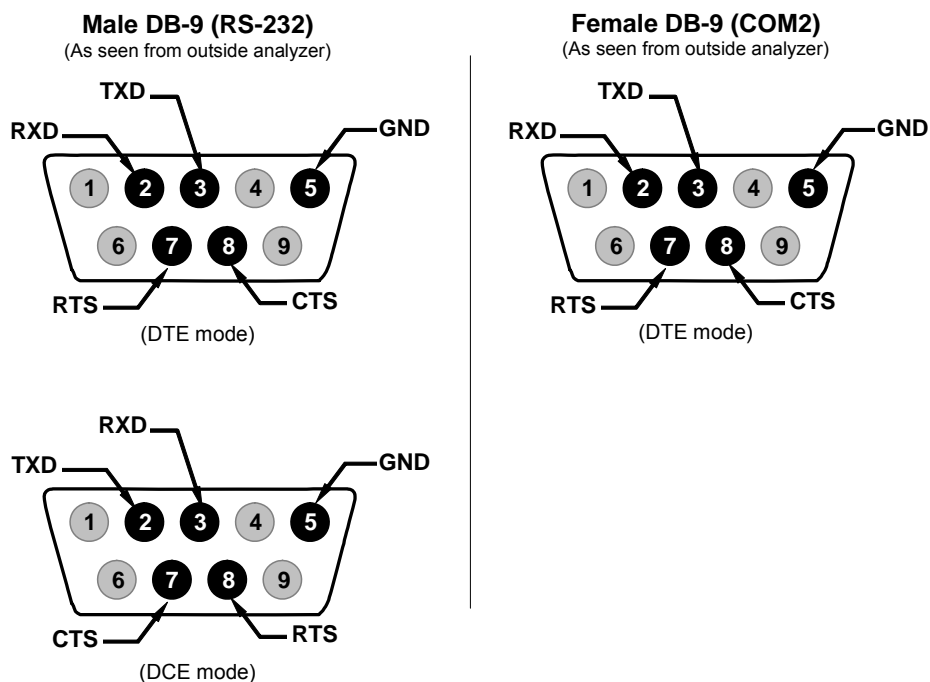

Figure 6-8: Back Panel connector Pin-Outs for COM1 & COM2 in RS-232 mode.

The signals from these two connectors are routed from the motherboard via a wiring harness to two 10-pin connectors on the CPU card, CN3 (COM1) and CN4 (COM2).

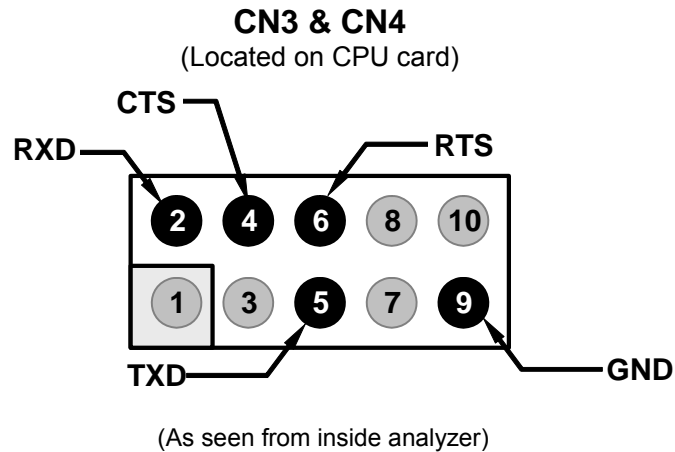

Figure 6-9: CPU connector Pin-Outs for COM1 & COM2 in RS-232 mode.

Teledyne Instruments offers two mating cables, one of which should be applicable for your use.

- Part number WR000077, a DB-9 female to DB-9 female cable, 6 feet long. Allows connection of COM1 with the serial port of most personal computers. Also available as Option 60 (See Section 5.5.1).
- Part number WR000024, a DB-9 female to DB-25 male cable. Allows connection to the most common styles of modems (e.g. Hayes-compatible) and code activated switches.

Both cables are configured with straight-through wiring and should require no additional adapters.

To assist in properly connecting the serial ports to either a computer or a modem, there are activity indicators just above the RS-232 port. Once a cable is connected between the analyzer and a computer or modem, both the red and green LEDs should be on. If the lights for COM 1 are not lit, use small switch on the rear panel to switch it between DTE and DCE modes (See Section 6.11.4). If both LEDs are still not illuminated, check the cable for proper wiring.

6.11.3. RS-485 Configuration of COM2

As delivered from the factory, COM2 is configured for RS-232 communications. This port can be re-configured for operation as a non-isolated, half-duplex RS-485 port capable of supporting up to 32 instruments with a maximum distance between the host and the furthest instrument being 4000 feet. If you require full-duplex or isolated operation, please contact Teledyne Instruments Customer Service.

- To reconfigure COM2 as an RS-285 port set switch 6 of SW1 to the ON position (see Figure 6-10).
- The RS-485 port can be configured with or without a 150 Ω termination resistor. To include the resistor, install jumper at position JP3 on the CPU board (see Figure 6-10). To configure COM2 as an un-terminated RS-485 port leave JP3 open.

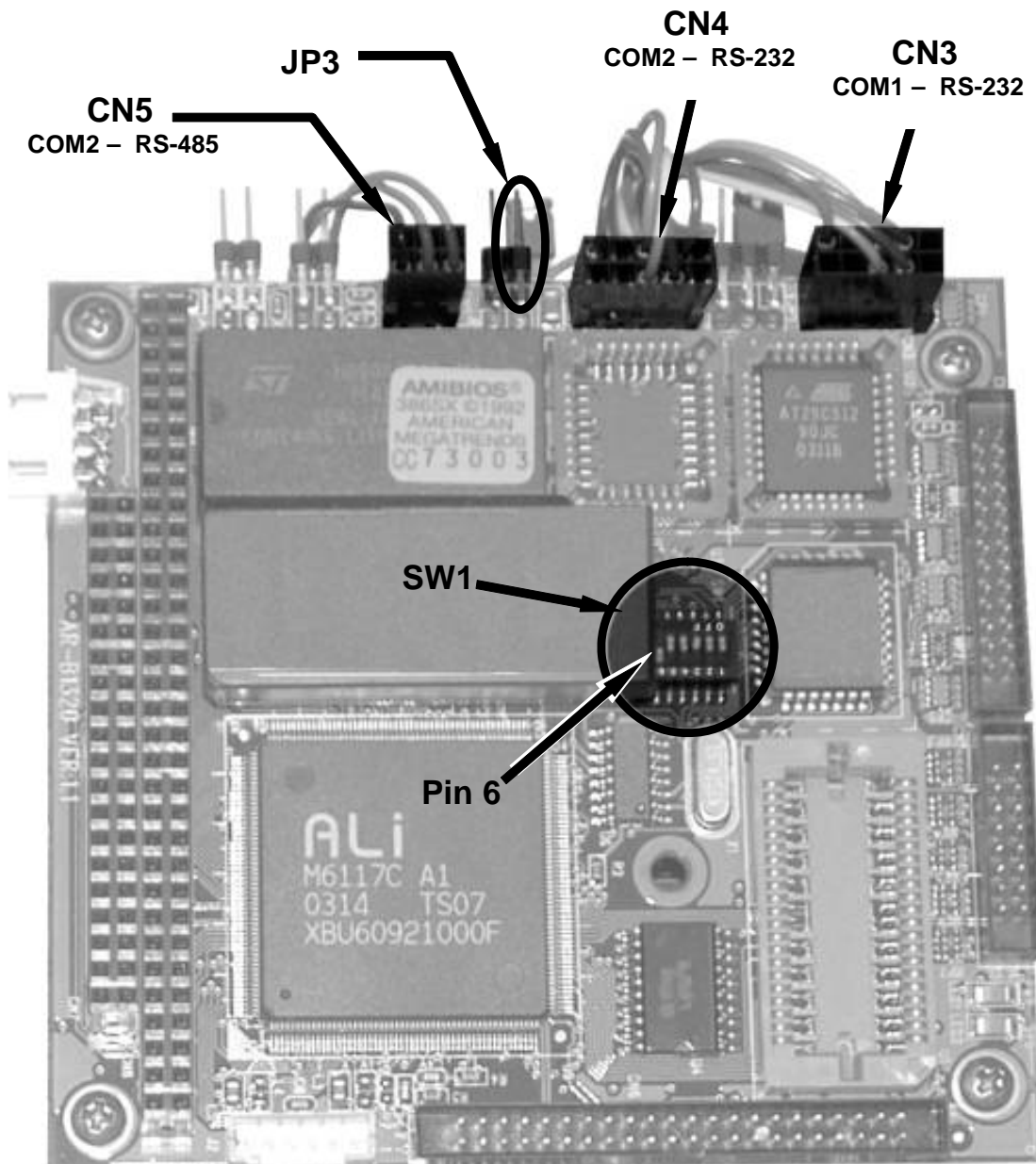

Figure 6-10: CPU card Locations of RS-232/486 Switches, Connectors and Jumpers

When COM2 is configured for RS-485 operation the port uses the same female DB-9 connector on the back of the instrument as when Com2 is configured for RS-232 operation, however, the pin assignments are different.

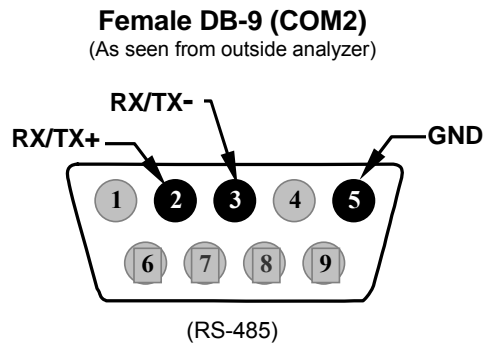

Figure 6-11: Back Panel connector Pin-Outs for COM2 in RS-485 mode.

The signal from this connector is routed from the motherboard via a wiring harness to a 6-pin connector on the CPU card, CN5.

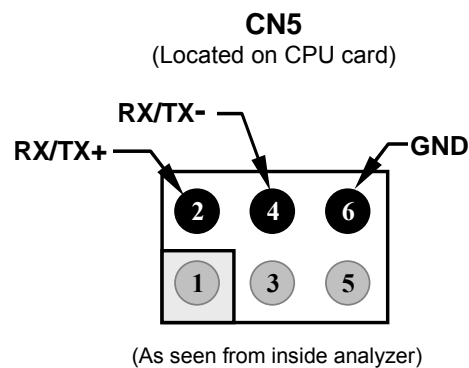

Figure 6-12: CPU connector Pin-Outs for COM2 in RS-485 mode.

6.11.4. DTE and DCE Communication

RS-232 was developed for allowing communications between data terminal equipment (DTE) and data communication equipment (DCE). Basic terminals always fall into the DTE category whereas modems are always considered DCE devices. The difference between the two is the pin assignment of the Data Receive and Data Transmit functions. DTE devices receive data on pin 2 and transmit data on pin 3; DCE devices receive data on pin 3 and transmit data on pin 2.

To allow the analyzer to be used with terminals (DTE), modems (DCE) and computers (which can be either), a switch mounted below the serial ports on the rear panel allows the user to switch between the two functions.

6.11.5. COMM Port Communication Modes

Each of the analyzer's serial ports can be configured to operate in a number of different modes, listed in Table 6-10 which can be combined by adding the mode ID numbers. For example, quiet mode, computer mode and internet-enabled mode would carry a combined mode ID of 11, the standard configuration on the M360E **COM2** port. Note that each COM port needs to be configured independently.

Table 6-10: COMM Port Communication modes

MODE ¹	ID	DESCRIPTION
QUIET	1	Quiet mode suppresses any feedback from the analyzer (iDAS reports, and warning messages) to the remote device and is typically used when the port is communicating with a computer program such as APICOM. Such feedback is still available but a command must be issued to receive them.
COMPUTER	2	Computer mode inhibits echoing of typed characters and is used when the port is communicating with a computer program, such as APICOM.
SECURITY	4	When enabled, the serial port requires a password before it will respond. The only command that is active is the help screen (? CR).
HESSEN PROTOCOL	16	The Hessen communications protocol is used in some European countries. Teledyne Instruments part number 02252 contains more information on this protocol.
E, 7, 1	2048	When turned on this mode switches the COMM port settings from No parity; 8 data bits; 1 stop bit to Even parity; 7 data bits; 1 stop bit
RS-485	1024	Configures the COM2 Port for RS-485 communication. RS-485 mode has precedence over multidrop mode if both are enabled.
MULTIDROP PROTOCOL	32	Multidrop protocol allows a multi-instrument configuration on a single communications channel. Multidrop requires the use of instrument IDs.
ENABLE MODEM	64	Enables to send a modem initialization string at power-up. Asserts certain lines in the RS-232 port to enable the modem to communicate.
ERROR CHECKING ²	128	Fixes certain types of parity errors at certain Hessen protocol installations.
XON/XOFF HANDSHAKE ²	256	Disables XON/XOFF data flow control also known as software handshaking.
HARDWARE HANDSHAKE	8	Enables CTS/RTS style hardwired transmission handshaking. This style of data transmission handshaking is commonly used with modems or terminal emulation protocols as well as by Teledyne Instrument's APICOM software.
HARDWARE FIFO ²	512	Improves data transfer rate when on of the COMM ports.
COMMAND PROMPT	4096	Enables a command prompt when in terminal mode.

¹ Modes are listed in the order in which they appear in the **SETUP → MORE → COMM → COM[1 OR 2] → MODE** menu

² The default sting for this feature is **ON**. Do not disable unless instructed to by Teledyne Instruments Customer Service personnel.

Press the following keys to select a communication mode for a one of the COMM Ports, such as the following example where **HESSEN PROTOCOL** mode is enabled:

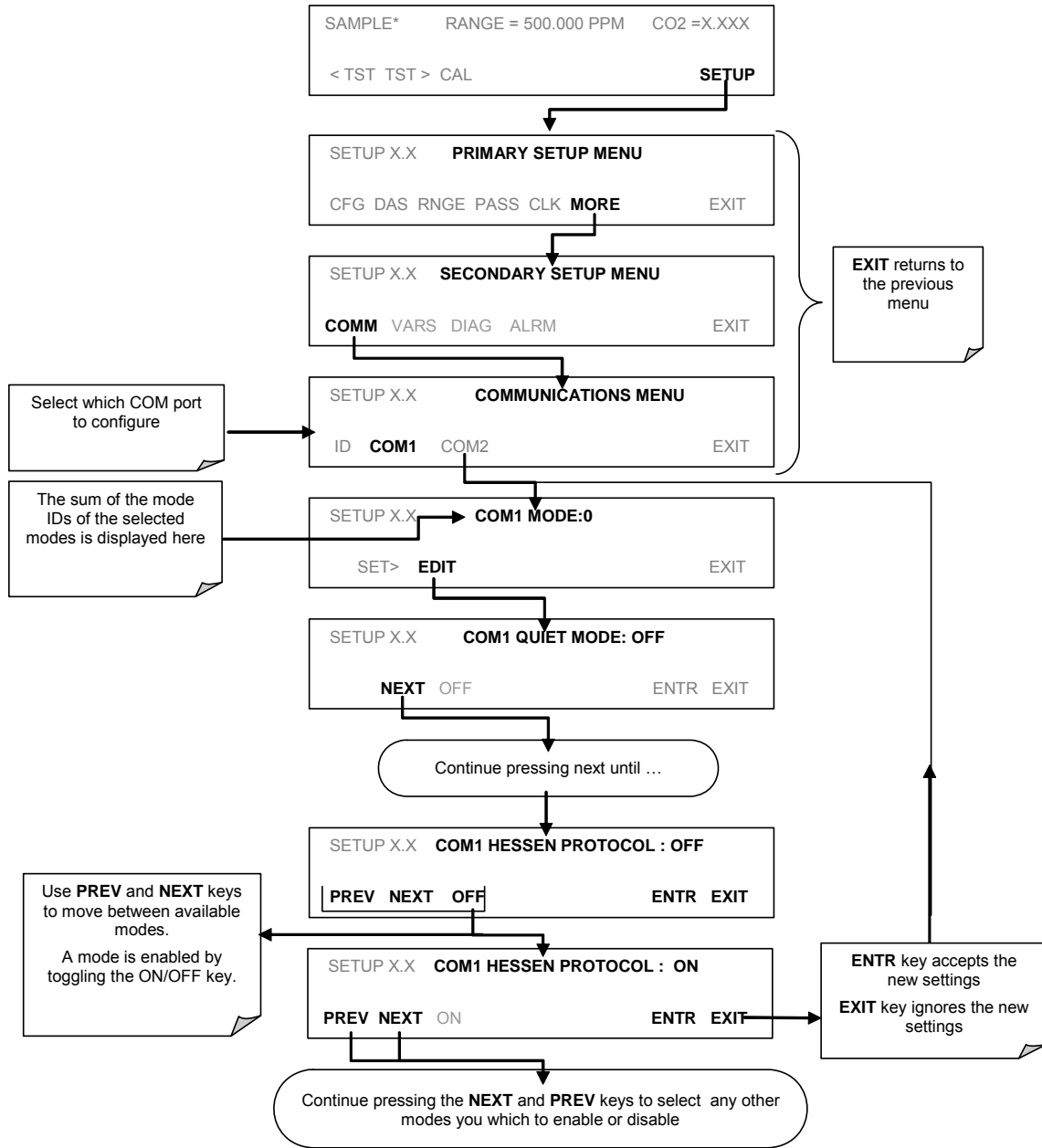

6.11.6. Ethernet Card Configuration

When equipped with the optional Ethernet interface, the analyzer can be connected to any standard 10BaseT Ethernet network via low-cost network hubs, switches or routers. The interface operates as a standard TCP/IP device on port 3000. This allows a remote computer to connect through the internet to the analyzer using APICOM, terminal emulators or other programs.

The firmware on board the Ethernet card automatically sets the communication modes and baud rate (115 200 kBaud) for the **COM2** port. Once the Ethernet option is installed and activated, the **COM2** submenu is replaced by a new submenu, **INET**. This submenu is used to manage and configure the Ethernet interface with your LAN or Internet Server(s).

The card has four LEDs that are visible on the rear panel of the analyzer, indicating its current operating status.

Table 6-11: Ethernet Status Indicators

LED	FUNCTION
LNK (green)	ON when connection to the LAN is valid.
ACT (yellow)	Flickers on any activity on the LAN.
TxD (green)	Flickers when the RS-232 port is transmitting data.
RxD (yellow)	Flickers when the RS-232 port is receiving data.

6.11.6.1. Ethernet Card COM2 Communication Modes and Baud Rate

The firmware on board the Ethernet card automatically sets the communication modes for the COM2 port. The baud rate is also automatically set at 115 200 kBaud.

6.11.6.2. Configuring the Ethernet Interface Option using DHCP

The Ethernet option for you M360E uses Dynamic Host Configuration Protocol (DHCP) to automatically configure its interface with your LAN. This requires your network servers also be running DHCP. The analyzer will do this the first time you turn the instrument on after it has been physically connected to your network. Once the instrument is connected and turned on it will appear as an active device on your network without any extra set up steps or lengthy procedures.

Should you need to, the Ethernet configuration properties are viewable via the analyzer's front panel See Table 6-12.

Table 6-12: LAN/Internet Configuration Properties

PROPERTY	DEFAULT STATE		DESCRIPTION
DHCP STATUS	On	Editable	This displays whether the DHCP is turned ON or OFF.
INSTRUMENT IP ADDRESS	Configured by DHCP	EDIT key disabled when DHCP is ON	This string of four packets of 1 to 3 numbers each (e.g. 192.168.76.55.) is the address of the analyzer itself.
GATEWAY IP ADDRESS	Configured by DHCP	EDIT key disabled when DHCP is ON	A string of numbers very similar to the Instrument IP address (e.g. 192.168.76.1.) that is the address of the computer used by your LAN to access the Internet.
SUBNET MASK	Configured by DHCP	EDIT key disabled when DHCP is ON	Also a string of four packets of 1 to 3 numbers each (e.g. 255.255.252.0) that defines that identifies the LAN the device is connected to. All addressable devices and computers on a LAN must have the same subnet mask. Any transmissions sent devices with different assumed to be outside of the LAN and are routed through gateway computer onto the Internet.
TCP PORT	3000	Editable	This number defines the terminal control port by which the instrument is addressed by terminal emulation software, such as Internet or Teledyne Instruments' APICOM.
HOST NAME	M360E	Editable	The name by which your analyzer will appear when addressed from other computers on the LAN or via the Internet. While the default setting for all Teledyne Instruments M360E analyzers is "m360e" the host name may be changed to fit customer needs.
¹ Do not change the setting for this property unless instructed to by Teledyne Instruments Customer Service personnel.			

NOTE

It is a good idea to check these settings the first time you power up your analyzer after it has been physically connected to the LAN/Internet to make sure that the DHCP has successfully downloaded the appropriate information from you network server(s).

If the gateway IP, instrument IP and the subnet mask are all zeroes (e.g. "0.0.0.0"), the DCHP was not successful.

**You may have to manually configure the analyzer's Ethernet properties.
See your network administrator.**

To view the above properties, press:

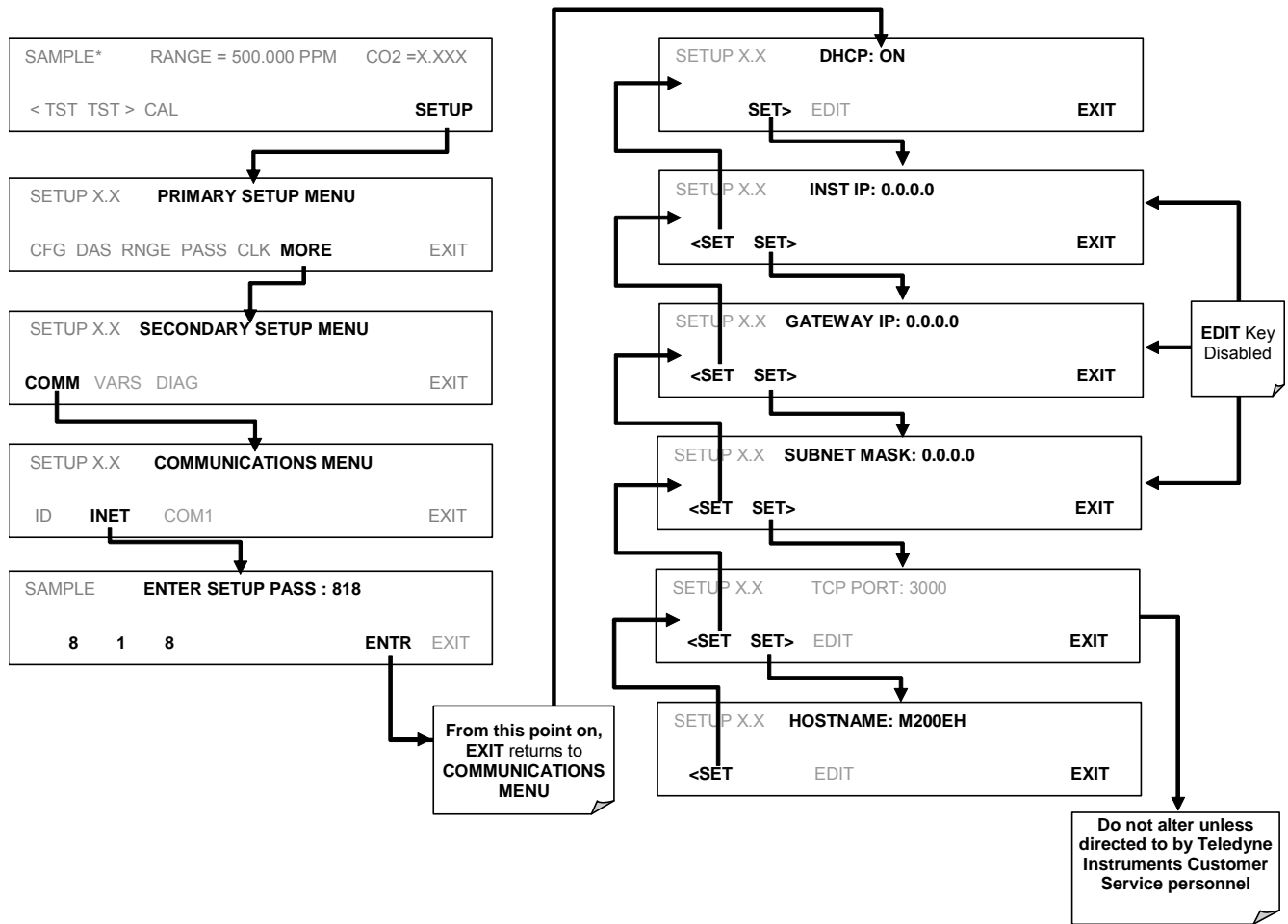

6.11.6.3. Manually Configuring the Network IP Addresses

There are several circumstances when you may need to manually configure the interface settings of the analyzer's Ethernet card. The **INET** sub-menu may also be used to edit the Ethernet card's configuration properties

- Your LAN is not running a DHCP software package,
- The DHCP software is unable to initialize the analyzer's interface;
- You wish to program the interface with a specific set of IP addresses that may not be the ones automatically chosen by DHCP.

Editing the Ethernet Interface properties is a two step process.

STEP 1: Turn DHCP OFF: While DHCP is turned **ON**, the ability to manually set **INSTRUMENT IP**, **GATEWAY IP** and **SUBNET MASK** is disabled

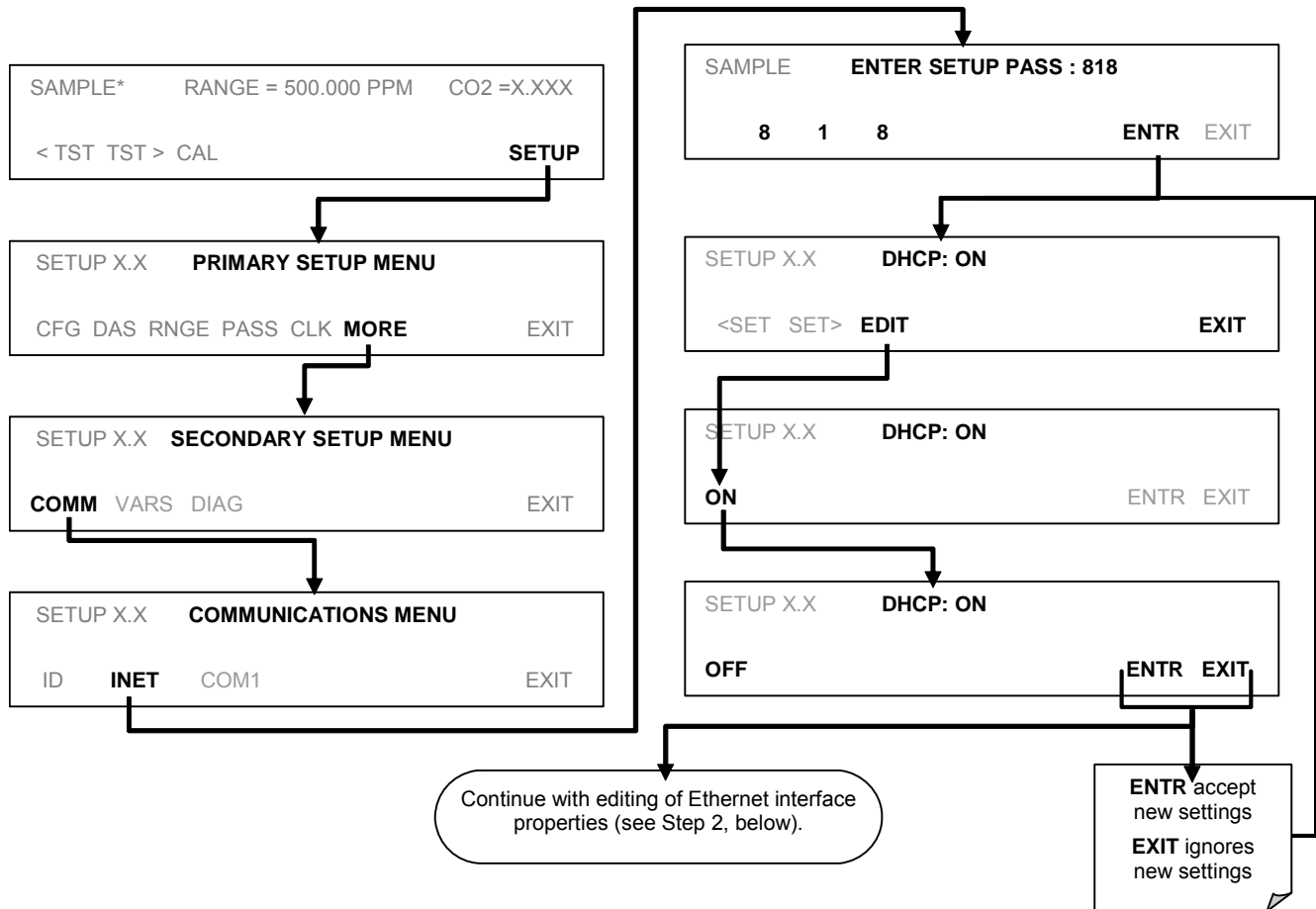

STEP 2: Configure the **INSTRUMENT IP**, **GATEWAY IP** and **SUBNET MASK** addresses by pressing:

Internet Configuration Keypad Functions

KEY	FUNCTION
[0]	Press this key to cycle through the range of numerals and available characters ("0-9" & ".").
<CH CH>	Moves the cursor one character left or right.
DEL	Deletes a character at the cursor location.
ENTR	Accepts the new setting and returns to the previous menu.
EXIT	Ignores the new setting and returns to the previous menu.

Some keys only appear as needed.

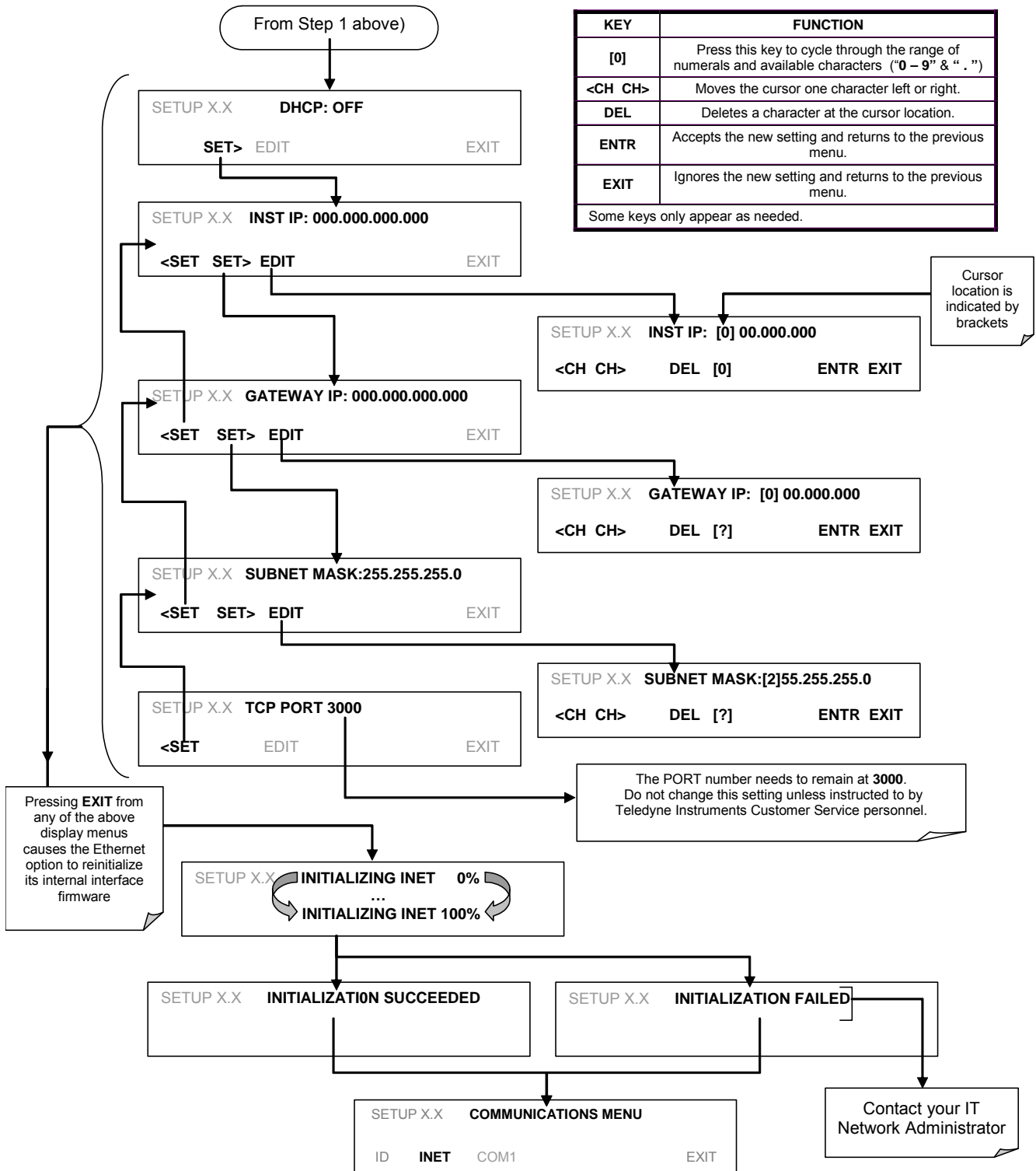

6.11.6.4. Changing the Analyzer's HOSTNAME

The **HOSTNAME** is the name by which the analyzer appears on your network. The default name for all Teledyne Instruments Model 360E analyzers is **M360E**. To change this name (particularly if you have more than one Model 360E analyzer on your network), press.

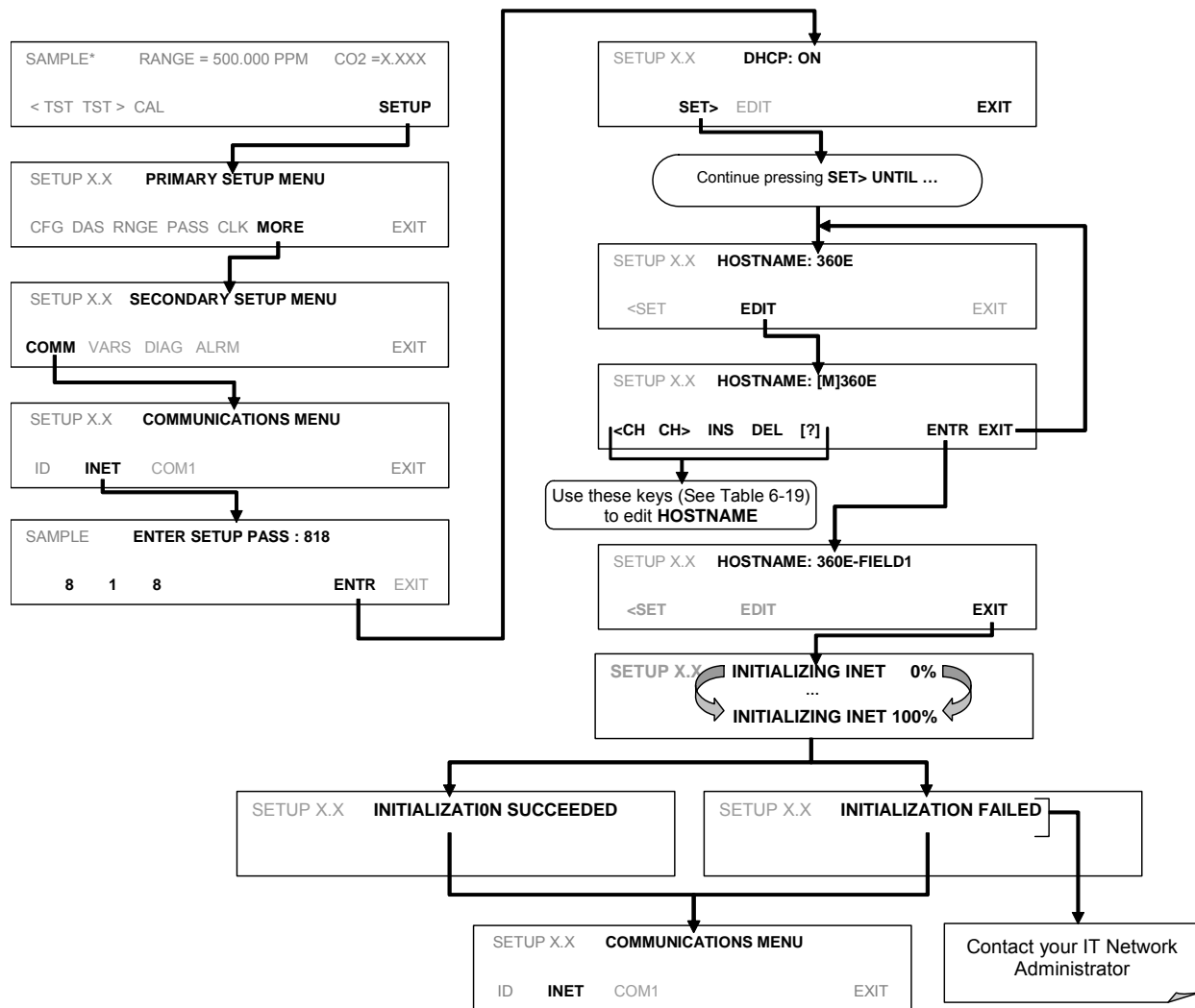

Table 6-13: Internet Configuration Keypad Functions

KEY	FUNCTION
<CH	Moves the cursor one character to the left.
CH>	Moves the cursor one character to the right.
INS	Inserts a character before the cursor location.
DEL	Deletes a character at the cursor location.
[?]	Press this key to cycle through the range of numerals and characters available for insertion. 0-9, A-Z, space ' ~ ! © # \$ % ^ & * () - _ = + [] { } < > \ ; : , . / ?
ENTR	Accepts the new setting and returns to the previous menu.
EXIT	Ignores the new setting and returns to the previous menu.

Some keys only appear as needed.

6.11.7. Multidrop RS-232 Set Up

The RS-232 multidrop consists of a printed circuit assembly that plugs onto the CN3, CN4, and CN5 connectors of the CPU card (see Figures 6-10 and 6-13) and the cabling to connect it to the analyzer's motherboard. This PCA includes all circuitry required to enable your analyzer for multidrop operation. It converts the instrument's COM1 port to multidrop configuration allowing up to eight analyzers to be connected the same I/O port of the host computer.

Because both of the DB9 connectors on the analyzer's back panel are needed to construct the multidrop chain, COM2 is no longer available for separate RS-232 or RS-485 operation; however, with the addition of an Ethernet Option (option 63, See Section 5.5.3 and 6.11.6) the COM2 port is available for communication over a 10BaseT LAN.

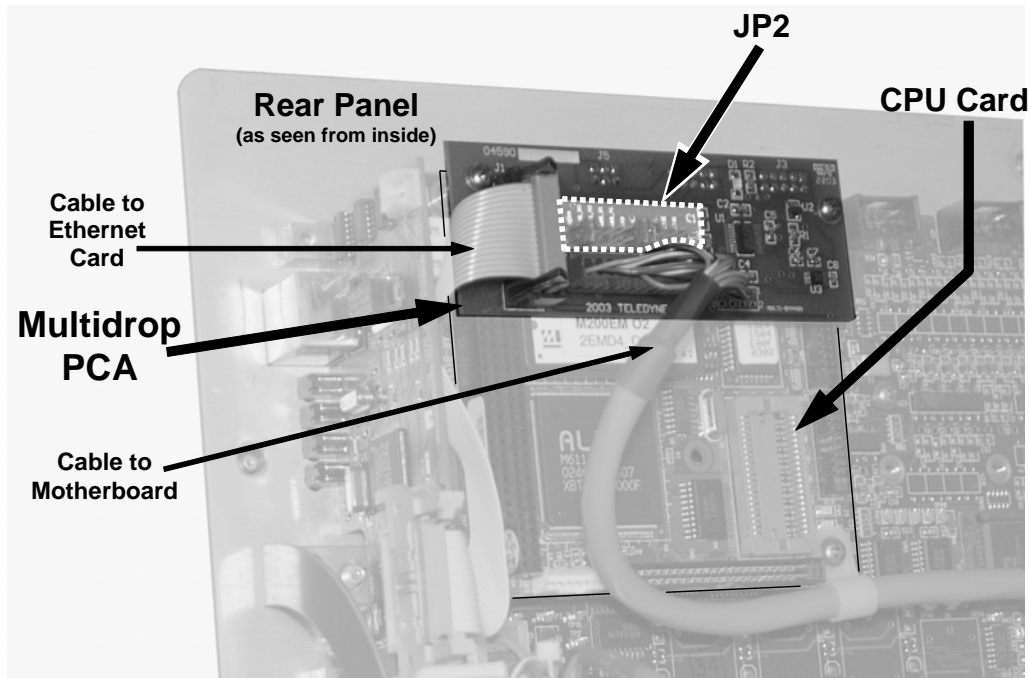

Figure 6-13: Location of JP2 on RS232-Multidrop PCA (option 62)

Each analyzer in the multidrop chain must have:

- One Teledyne Instruments option 62 installed.
- One 6' straight-through, DB9 male → DB9 Female cable (Teledyne Instruments P/N WR0000101) is required for each analyzer.

To set up the network, for each analyzer:

4. Turn the analyzer on and change its ID code (See Section 6.11.1) to a unique 4-digit number.
5. Remove the top cover (See Section 3.1) of the analyzer and locate JP2 on the multidrop PCA (see Figure 6-13)
6. Make sure that the jumpers are in place connection pins 9 ↔ 10 and 11 ↔ 12.
7. If the analyzer is to be the last instrument on the chain, make sure a jumper is in place connecting pins 21 ↔ 22.

8. If you are adding an analyzer to the end of an already existing chain, don't forget to remove JP2, pins 21 ↔ 22 on the multidrop PCA on the analyzer that was previous the last instrument in the chain.
9. Close the instrument.
10. Using straight-through, DB9 male → DB9 Female cables interconnect the host and the analyzers as shown in Figure 6-14.

NOTE:

Teledyne Instruments recommends setting up the first link, between the Host and the first analyzer and testing it before setting up the rest of the chain.

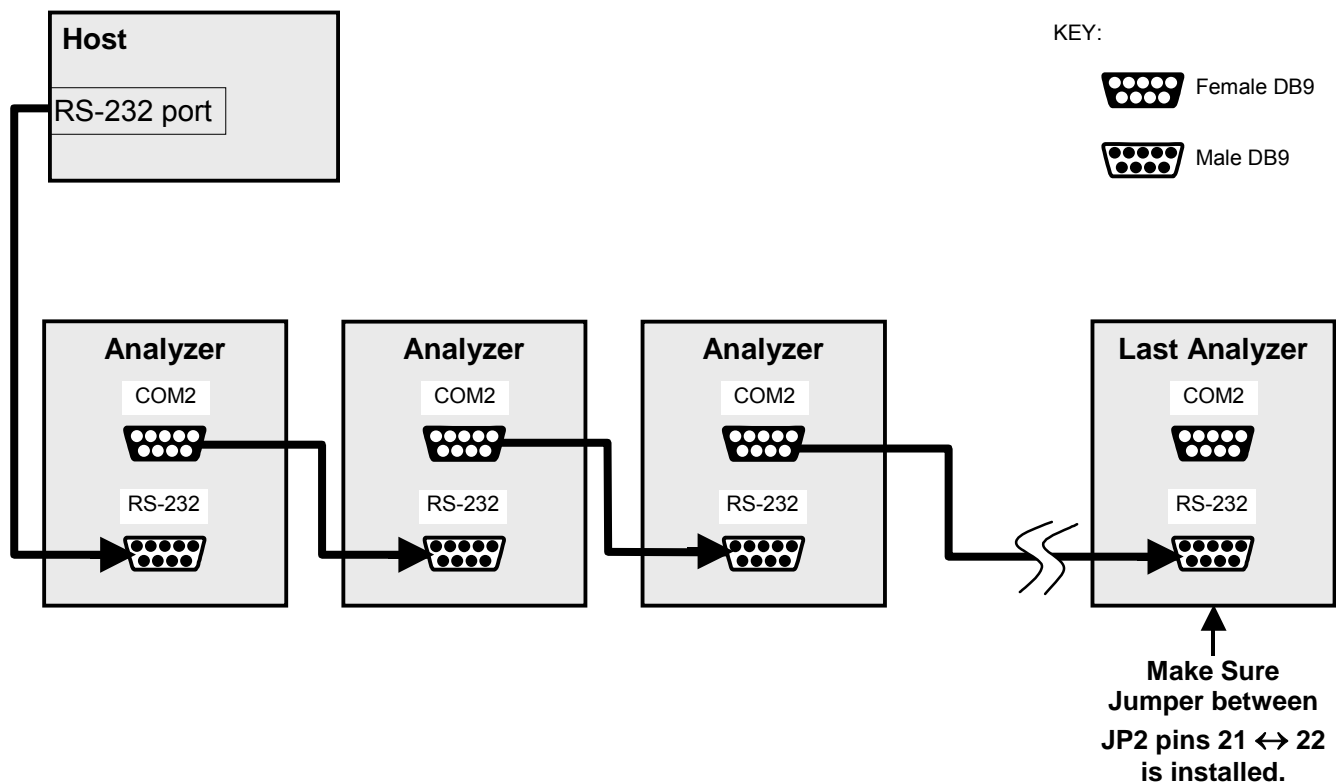
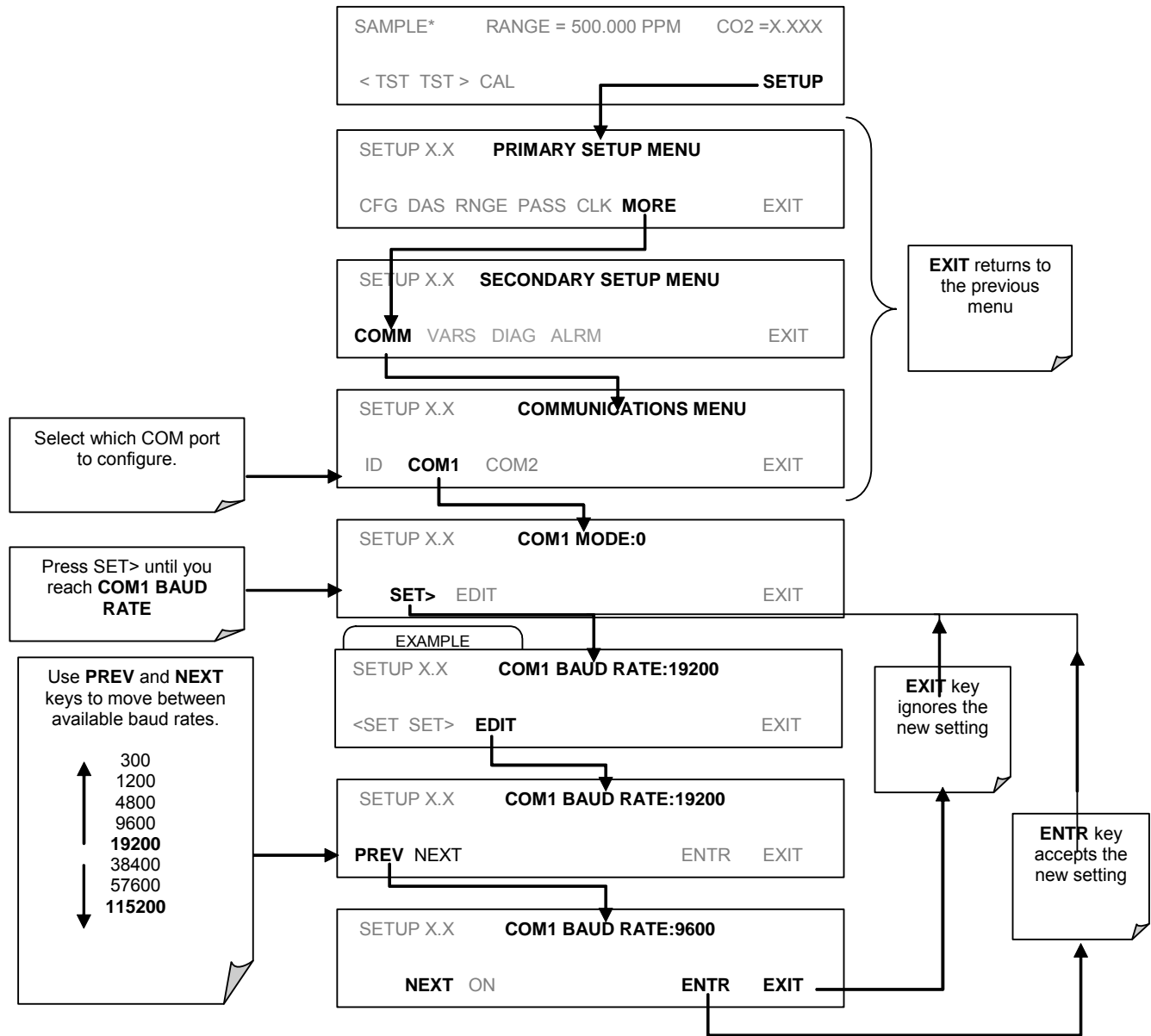

Figure 6-14: RS232-Multidrop PCA Host/Analyzer Interconnect Diagram

6.11.8. COM Port Baud Rate

To select the baud rate of one of the COM Ports, press:



6.11.9. COM Port Testing

The serial ports can be tested for correct connection and output in the **COMM** menu. This test sends a string of 256 'w' characters to the selected COM port. While the test is running, the red LED on the rear panel of the analyzer should flicker.

To initiate the test press the following key sequence.

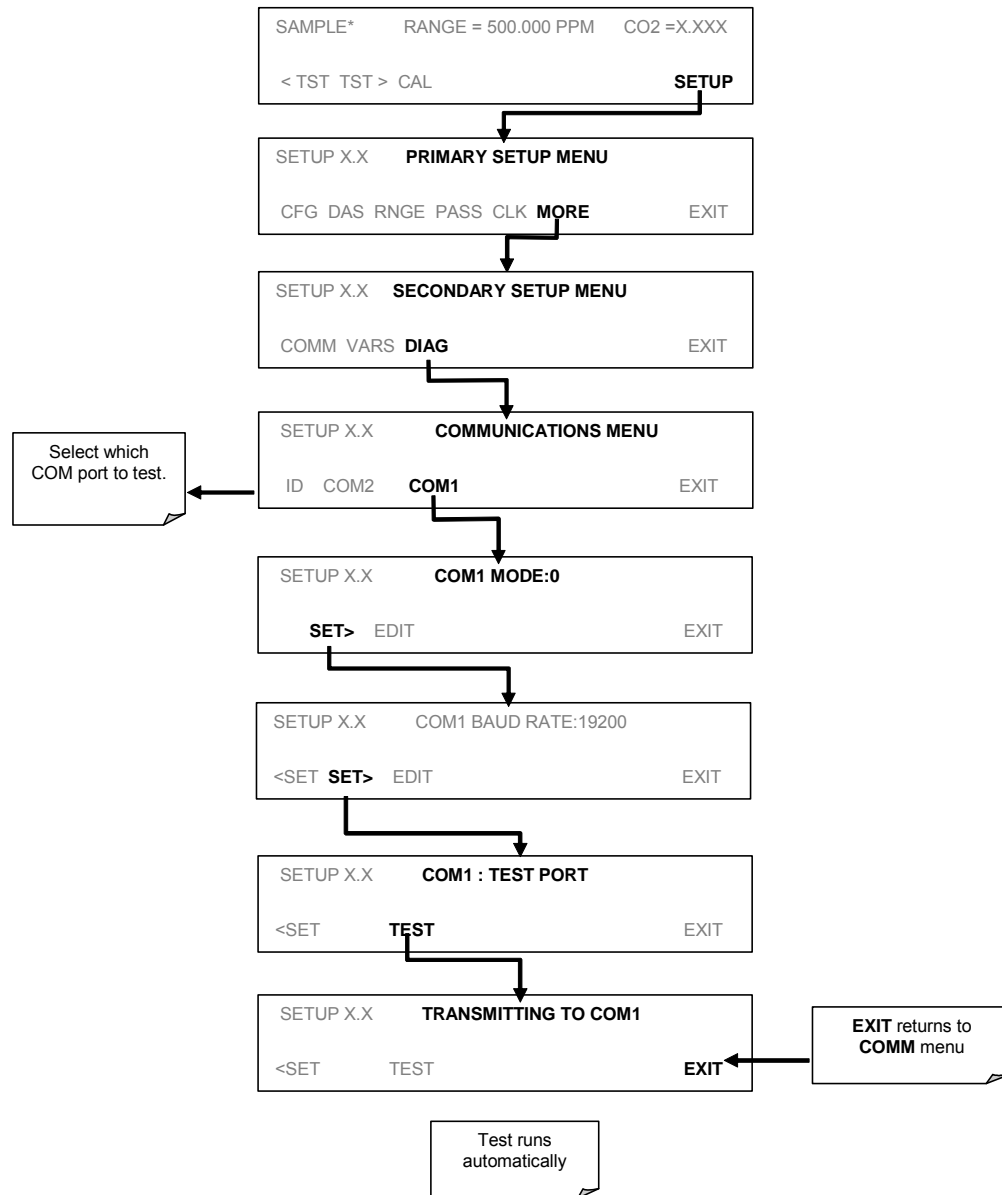

6.12. SETUP → MORE → VARS: Internal Variables (VARS)

The M360E has several-user adjustable software variables, which define certain operational parameters. Usually, these variables are automatically set by the instrument's firmware, but can be manually re-defined using the VARS menu. Table 6-14 lists all variables that are available within the 818 password protected level.

Table 6-14: Variable Names (VARS) Revision B.3

NO.	VARIABLE	DESCRIPTION	ALLOWED VALUES
0	DAS_HOLD_OFF	Changes the internal data acquisition system (iDAS) hold-off time, which is the duration when data are not stored in the iDAS because the software considers the data to be questionable. That is the case during warm-up or just after the instrument returns from one of its calibration modes to SAMPLE mode. DAS_HOLD_OFF can be disabled entirely in each iDAS channel.	Can be between 0.5 and 20 minutes Default=15 min.
1	CONC_PRECISION	Allows the user to set the number of significant digits to the right of the decimal point display of concentration and stability values.	AUTO, 1, 2, 3, 4 Default=AUTO
2	STABIL_GAS	Selects which gas measurement is displayed when the STABIL test function is selected.	CO; CO ₂ & O ₂ ¹
3	DYN_ZERO	Dynamic zero automatically adjusts offset and slope of the CO ₂ response when performing a zero point calibration during an AutoCal (Chapter 7).	ON/OFF
4	DYN_SPAN	Dynamic span automatically adjusts slope and slope of the CO ₂ response when performing a zero point calibration during an AutoCal (Chapter 7). Note that the DYN_ZERO and DYN_SPAN features are not allowed for applications requiring EPA equivalency.	ON/OFF
5	CLOCK_ADJ	Adjusts the speed of the analyzer's clock. Choose the + sign if the clock is too slow, choose the - sign if the clock is too fast.	-60 to +60 s/day

¹ O₂ option is only available in analyzers with O₂ sensor options installed.

To access and navigate the VARS menu, use the following key sequence.

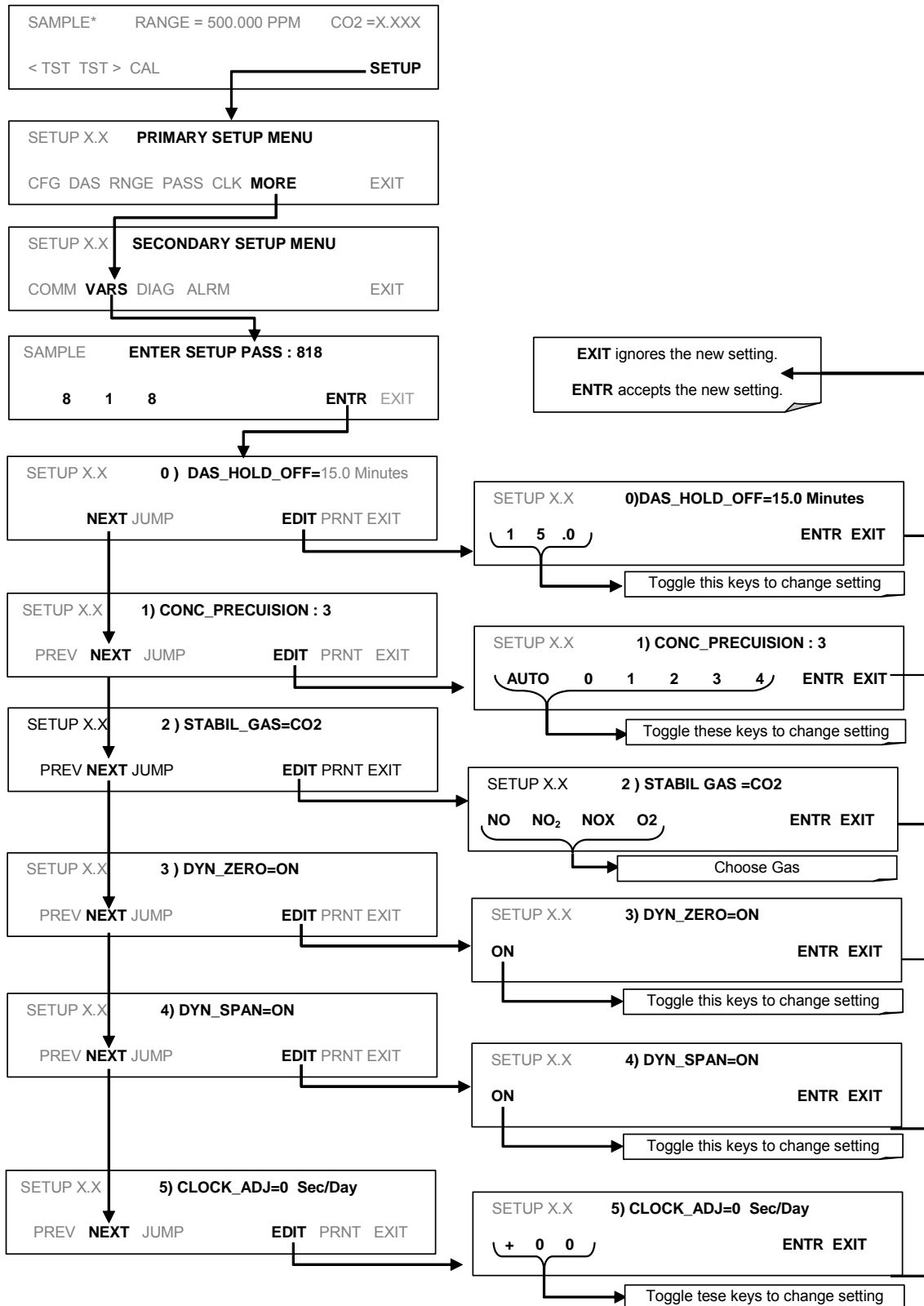

6.13. SETUP → MORE → DIAG: Using the Diagnostics Functions

A series of diagnostic tools is grouped together under the **SETUP→MORE→DIAG** menu. As these parameters are dependent on firmware revision (see Menu Tree A-6 in Appendix A). The individual parameters, however, are explained in more detail in the indicated in 6-15. These tools can be used in a variety of troubleshooting and diagnostic procedures and are referred to in many places of the maintenance and trouble-shooting s.

Table 6-15: M360E Diagnostic (DIAG) Functions

DIAGNOSTIC FUNCTION AND MEANING	Front Panel Mode Indicator	
SIGNAL I/O: Allows observation of all digital and analog signals in the instrument. Allows certain digital signals such as valves and heaters to be toggled ON and OFF.	DIAG I/O	6.13.2
ANALOG OUTPUT: When entered, the analyzer performs an analog output step test. This can be used to calibrate a chart recorder or to test the analog output accuracy.	DIAG AOUT	6.13.3
ANALOG I/O CONFIGURATION: the signal levels of the instruments analog outputs may be calibrated (either individually or as a group). Various electronic parameters such as signal span, and offset are available for viewing and configuration.	DIAG AIO	6.13.4
ELECTRIC TEST: The analyzer is performing an electric test. This test simulates IR detector signal in a known manner so that the proper functioning of the sync/demod board can be verified.	DIAG OPTIC	6.13.5
DARK CALIBRATION: The analyzer is performing a dark calibration procedure. This procedure measures and stores the inherent dc offset of the sync/demod board electronics.	DIAG ELEC	6.13.6
PRESSURE CALIBRATION: The analyzer records the current output of the sample gas pressure sensor. This value is used by the CPU to compensate the CO ₂ concentration.	DIAG PCAL	6.13.7
FLOW CALIBRATION: This function is used to calibrate the gas flow output signals of sample gas and ozone supply. These settings are retained when exiting DIAG .	DIAG FCAL	6.13.8
TEST CHAN OUTPUT: Configures the A4 analog output channel.	DIAG TCHN	6.13.9

6.13.1. Accessing the Diagnostic Features

To access the **DIAG** functions press the following keys:

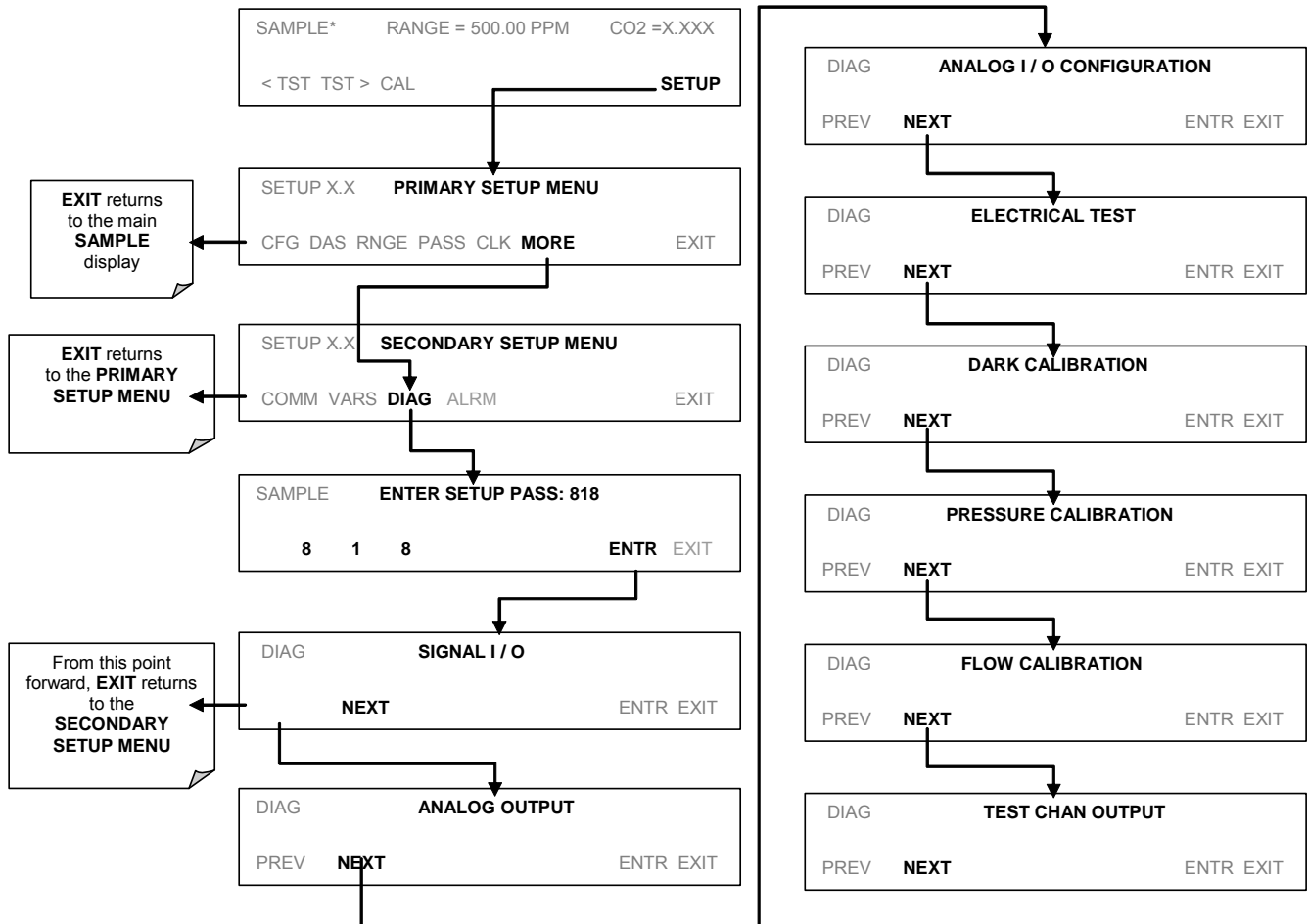

6.13.2. Signal I/O

The signal I/O diagnostic mode allows reviewing and changing the digital and analog input/output functions of the analyzer. See Appendix A-4 for a complete list of the parameters available for review under this menu.

NOTE

Any changes of signal I/O settings will remain in effect only until the signal I/O menu is exited. Exceptions are the ozone generator override and the flow sensor calibration, which remain as entered when exiting.

To enter the signal I/O test mode, press:

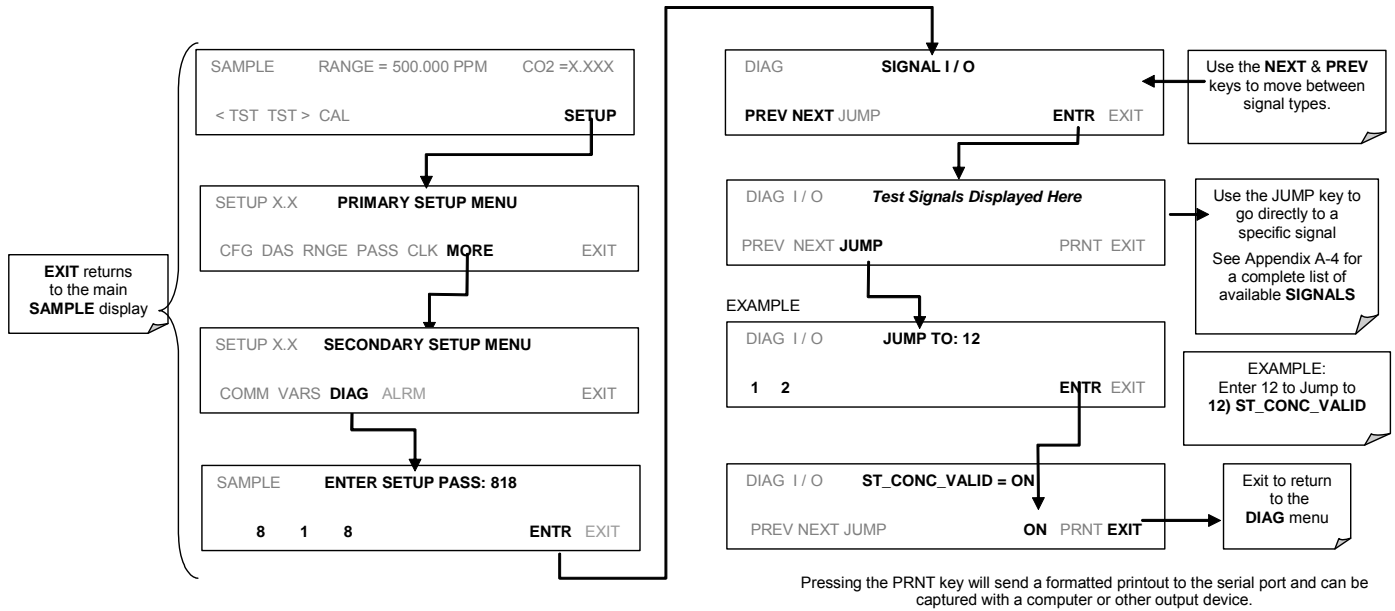

6.13.3. Analog Output Step Test

This test can be used to check the accuracy and proper operation of the analog outputs. The test forces all four analog output channels to produce signals ranging from 0% to 100% of the full scale range in 20% increments. This test is useful to verify the operation of the data logging/recording devices attached to the analyzer.

To begin the Analog Output Step Test press:

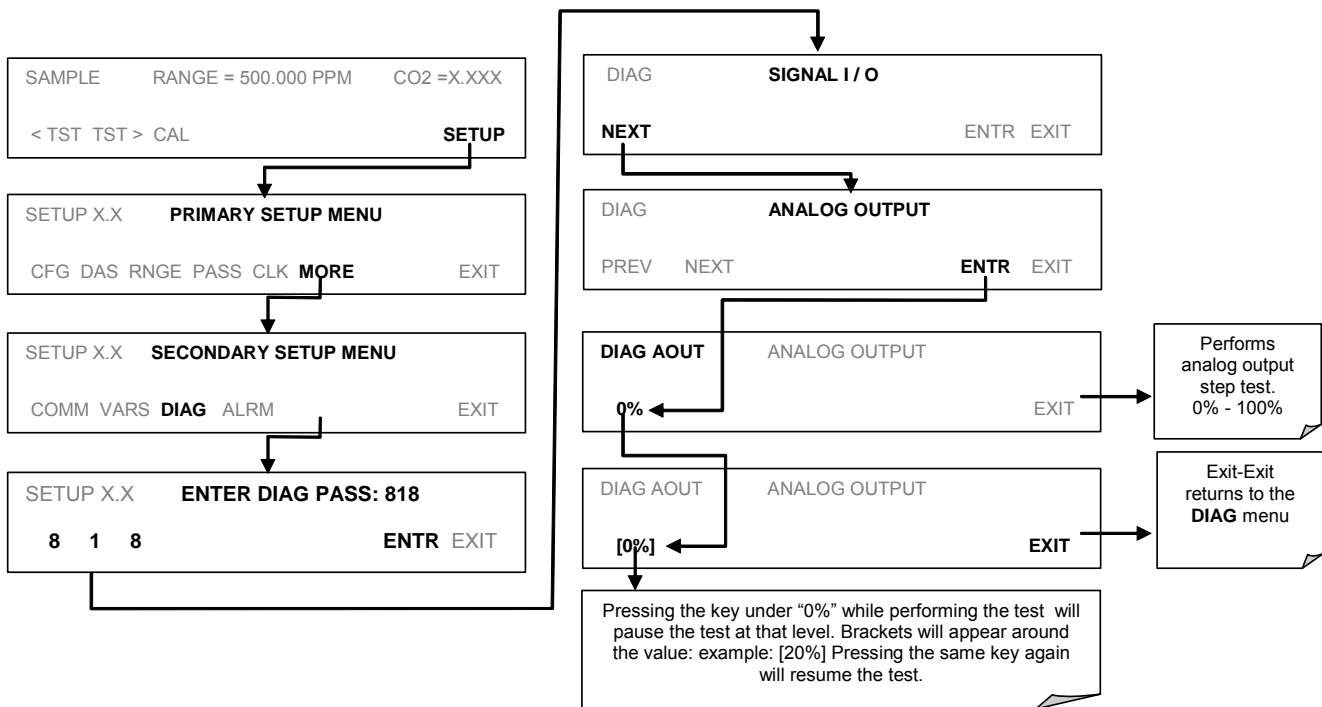

6.13.4. Analog I/O Configuration

The analog I/O functions that are available in the M360E are:

Table 6-16: DIAG - Analog I/O Functions

Sub Menu	Function
AOUTS CALIBRATED:	Shows the status of the analog output calibration (YES/NO) and initiates a calibration of all analog output channels.
CONC_OUT_1	Sets the basic electronic configuration of the A1 analog output (CO ₂). There are three options: Range: Selects the signal type (voltage or current loop) and full scale level of the output. REC_OFS: Allows setting a voltage offset (not available when RANGE is set to CURRENT loop. Auto_CAL: Performs the same calibration as AOUT CALIBRATED, but on this one channel only. NOTE: Any change to RANGE or REC_OFS requires recalibration of this output.
CONC_OUT_2	Same as for CONC_OUT_1 but for analog channel 2 (CO ₂)
TEST OUTPUT	Same as for CONC_OUT_1 but for analog channel 4 (TEST)
AIN CALIBRATED	Shows the calibration status (YES/NO) and initiates a calibration of the analog to digital converter circuit on the motherboard.

To configure the analyzer’s three analog outputs, set the electronic signal type of each channel and calibrate the outputs. This consists of:

- Selecting an output type (voltage or current, if an optional current output driver has been installed) and the signal level that matches the input requirements of the recording device attached to the channel, See Section 6.13.4.1.
- Calibrating the output channel. This can be done automatically or manually for each channel, see Section 6.13.4.2 and 6.13.4.3.
- Adding a bipolar recorder offset to the signal, if required (Section 6.13.4.2.)

In its standard configuration, the analyzer’s outputs can be set for the following DC voltages. Each range is usable from -5% to + 5% of the nominal range.

Table 6-17: Analog Output Voltage Ranges

RANGE	MINIMUM OUTPUT	MAXIMUM OUTPUT
0-0.1 V	-5 mV	+105 mV
0-1 V	-0.05 V	+1.05 V
0-5 V	-0.25 V	+5.25 V
0-10 V	-0.5 V	+10.5 V
The default offset for all ranges is 0 VDC.		

The following DC current output limits apply to the current loop modules:

Table 6-18: Analog Output Current Loop Range

RANGE	MINIMUM OUTPUT	MAXIMUM OUTPUT
0-20 mA	0 mA	20 mA
These are the physical limits of the current loop modules, typical applications use 2-20 or 4-20 mA for the lower and upper limits. Please specify desired range when ordering this option. The default offset for all ranges is 0 mA.		

Pin assignments for the output connector at the rear panel of the instrument are shown in Table 6-19.

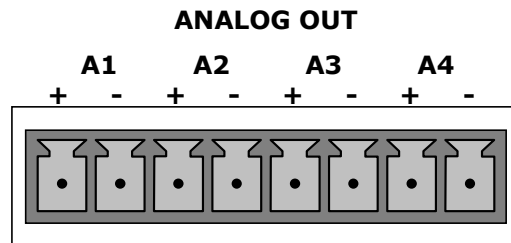

Table 6-19: Analog Output Pin Assignments

PIN	ANALOG OUTPUT	VOLTAGE SIGNAL	CURRENT SIGNAL
1	A1	V Out	I Out +
2		Ground	I Out -
3	A2	V Out	I Out +
4		Ground	I Out -
5	A3 ¹	V Out	I Out +
6		Ground	I Out -
7	A4	V Out	I Out +
8		Ground	I Out -
¹ Output A3 is only used when the O ₂ sensor option is installed			

See Figure 3-2 for the location of the analog output connector on the instrument's rear panel.

6.13.4.1. Analog Output Signal Type and Range Span Selection

To select an output signal type (DC Voltage or current) and level for one output channel, activate the ANALOG I/O CONFIGURATION MENU (See Section 6.13.1) then press:

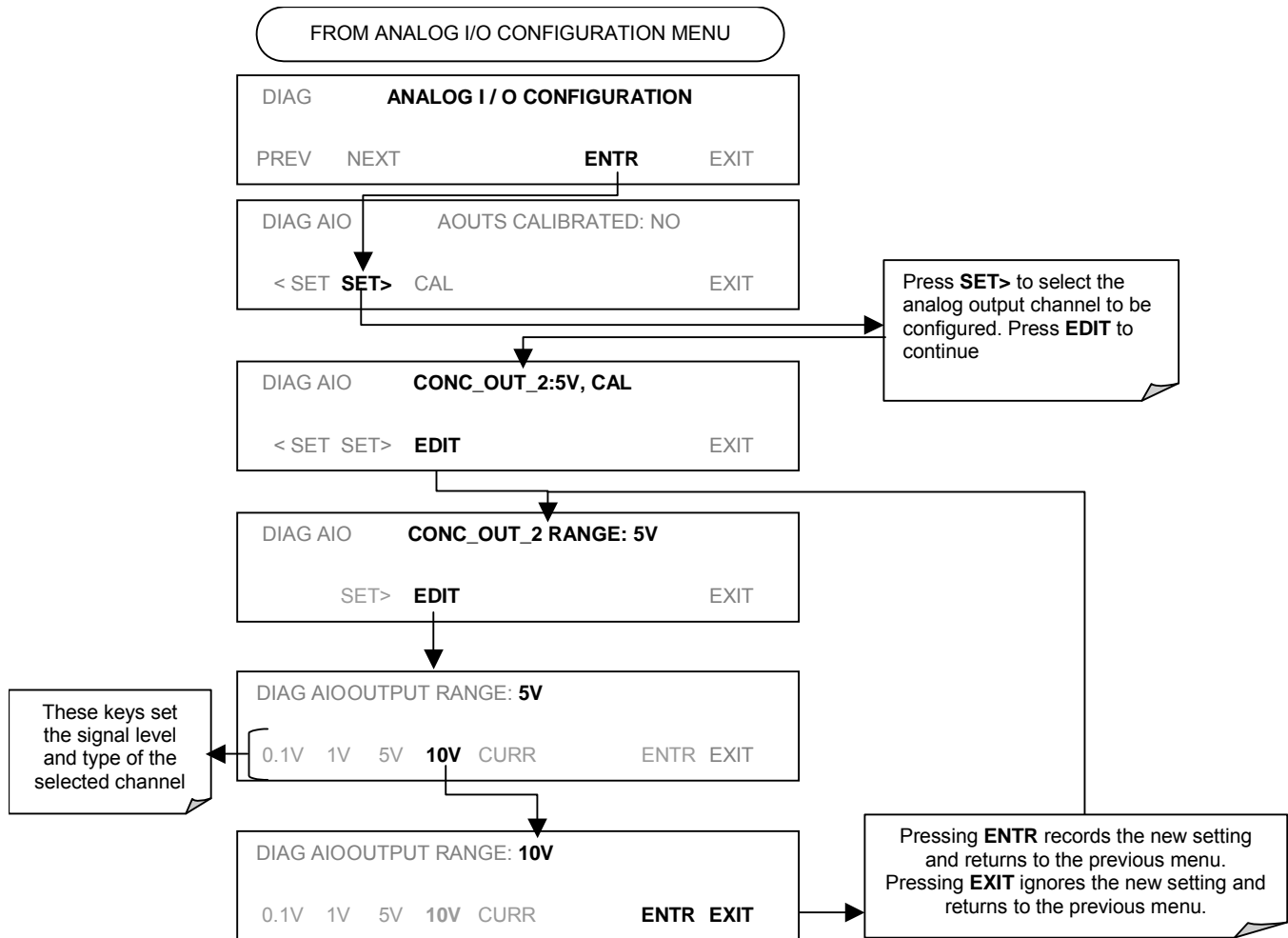

6.13.4.2. Analog Output Calibration Mode

The analog outputs can be calibrated automatically or manually. In its default mode, the instrument is configured for automatic calibration of all channels. Manual calibration should be used for the 0.1V range or in cases where the outputs must be closely matched to the characteristics of the recording device. Outputs configured for automatic calibration can be calibrated as a group or individually. Calibration of the analog outputs needs to be carried out on first startup of the analyzer (performed in the factory as part of the configuration process) or whenever re-calibration is required.

To calibrate the outputs as a group, activate the ANALOG I/O CONFIGURATION MENU (See Section 6.13.1), then press:

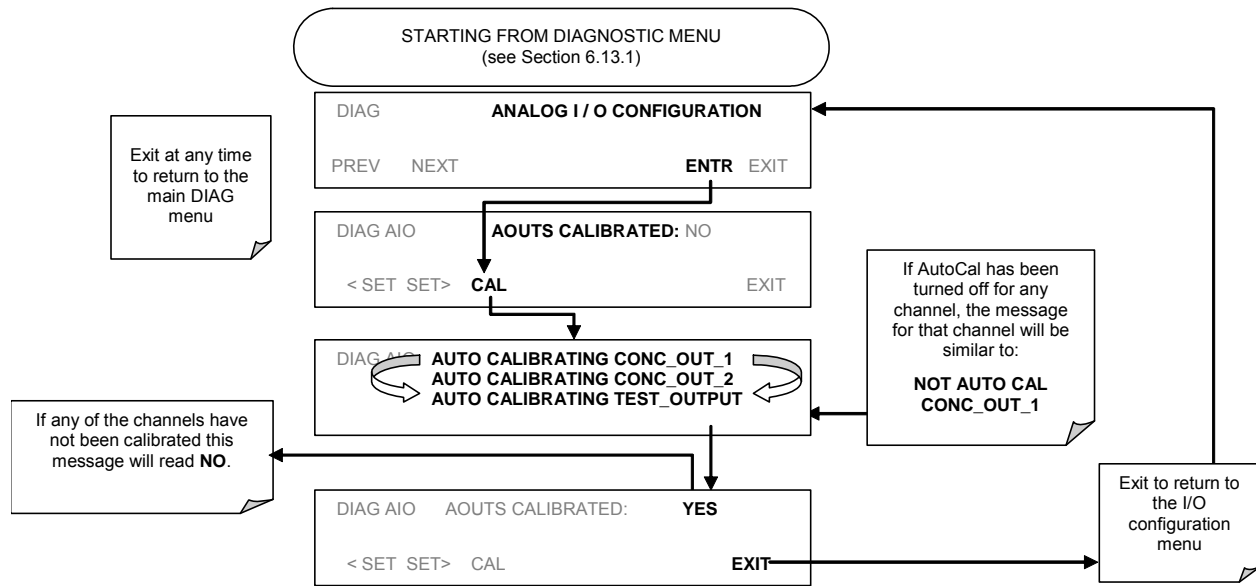

To automatically calibrate a single analog channel, activate the ANALOG I/O CONFIGURATION MENU (See Section 6.13.1), then press:

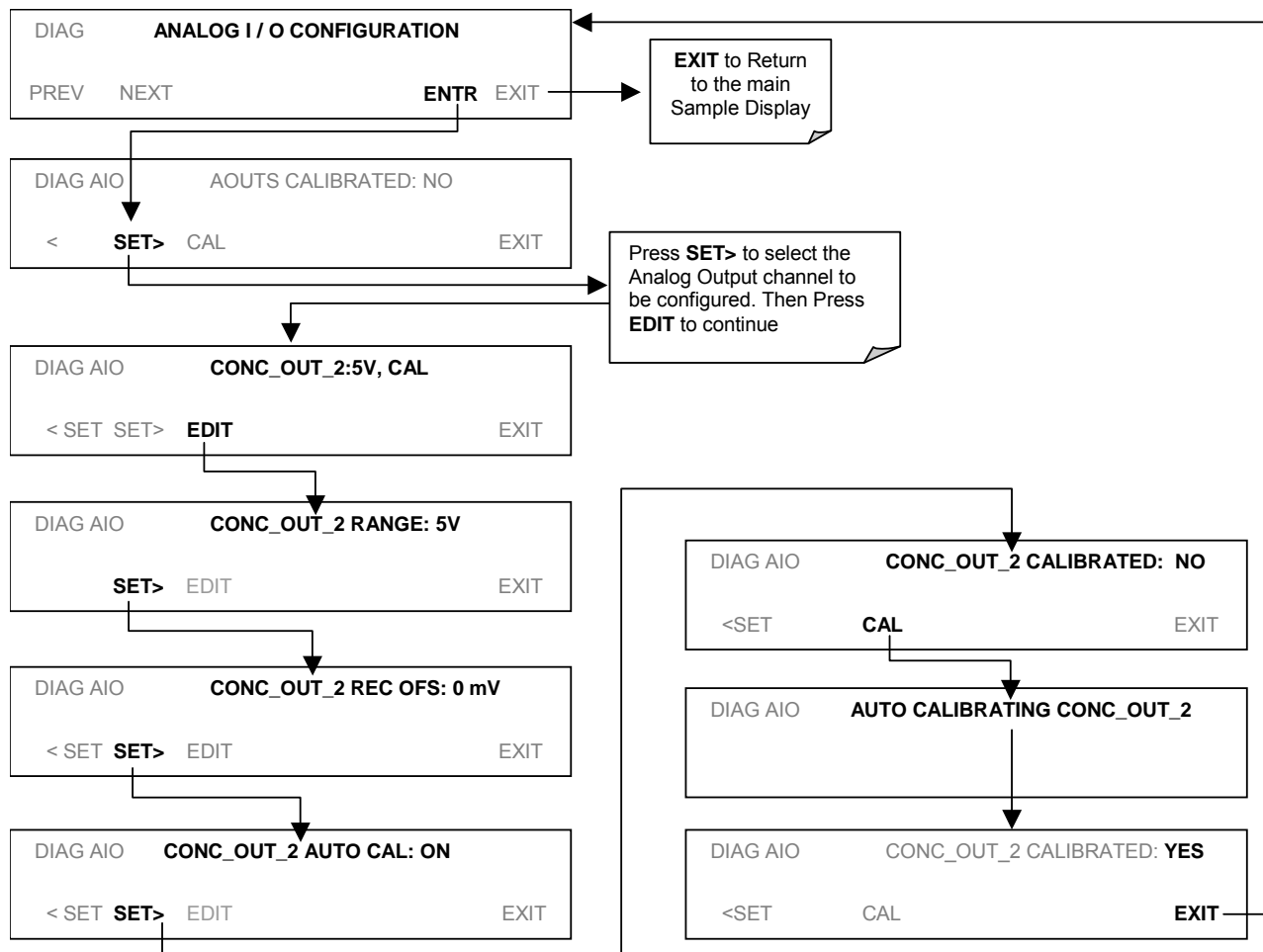

To select manual output calibration for a particular channel, activate the ANALOG I/O CONFIGURATION MENU (See Section 6.13.1), then press:

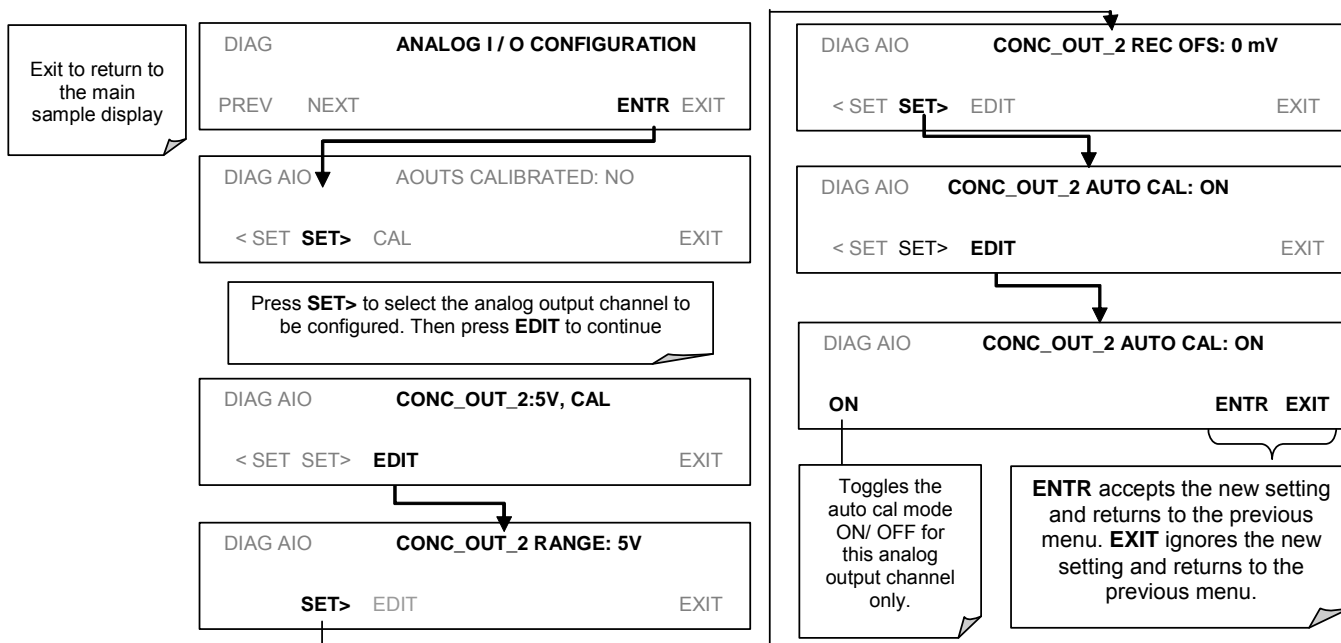

Now the analog output channels should either be automatically calibrated or they should be set to manual calibration, which is described next.

6.13.4.3. Manual Analog Output Calibration and Voltage Adjustment

For highest accuracy, the voltages of the analog outputs can be manually calibrated. Calibration is done through the instrument software with a voltmeter connected across the output terminals (Figure 6-15). Adjustments are made using the front panel keys by setting the zero-point first and then the span-point (Table 6-20).

The software allows this adjustment to be made in 100, 10 or 1 count increments.

Table 6-20: Voltage Tolerances for Analog Output Calibration

Full Scale	Zero Tolerance	Span Voltage	Span Tolerance
0.1 VDC	±0.0005V	90 mV	±0.001V
1 VDC	±0.001V	900 mV	±0.001V
5 VDC	±0.002V	4500 mV	±0.003V
10 VDC	±0.004V	4500 mV	±0.006V

NOTE

Outputs configured for 0.1V full scale should always be calibrated manually

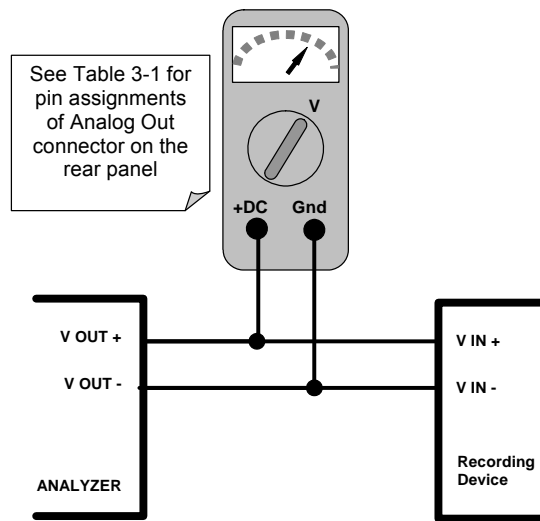
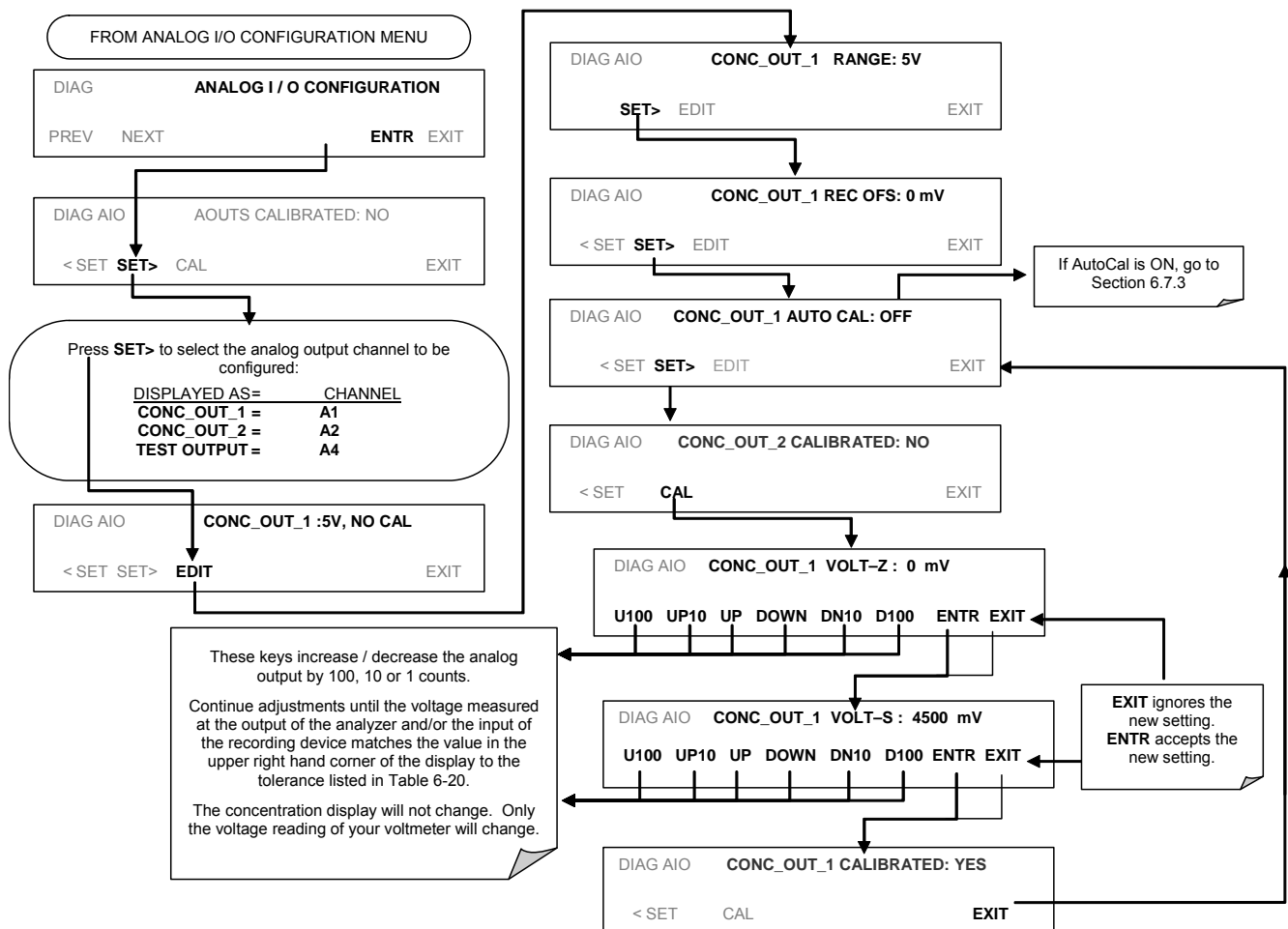

Figure 6-15: Setup for Calibrating Analog Voltage Outputs

To make these adjustments, the AOUT auto-calibration feature must be turned off (Section 6.13.4.2). Activate the ANALOG I/O CONFIGURATION MENU (See Section 6.13.1), then press:



6.13.4.4. Current Loop Output Adjustment

A current loop option is available and can be installed as a retrofit for each of the analog outputs of the analyzer (s 5.2). This option converts the DC voltage analog output to a current signal with 0-20 mA output current. The outputs can be scaled to any set of limits within that 0-20 mA range. However, most current loop applications call for either 2-20 mA or 4-20 mA range. All current loop outputs have a +5% over-range. Ranges with the lower limit set to more than 1 mA (e.g., 2-20 or 4-20 mA) also have a -5% under-range.

To switch an analog output from voltage to current loop after installing the current output printed circuit assembly, follow the instructions in Section 6.13.4.4 and select CURR from the list of options on the RANGE menu.

Adjusting the signal zero and span values of the current loop output is done by raising or lowering the voltage of the respective analog output. This proportionally raises or lowers the current produced by the current loop option.

Similar to the voltage calibration, the software allows this current adjustment to be made in 100, 10 or 1 count increments. Since the exact current increment per voltage count varies from output to output and from instrument to instrument, you will need to measure the change in the current with a current meter placed in series with the output circuit (Figure 6-16).

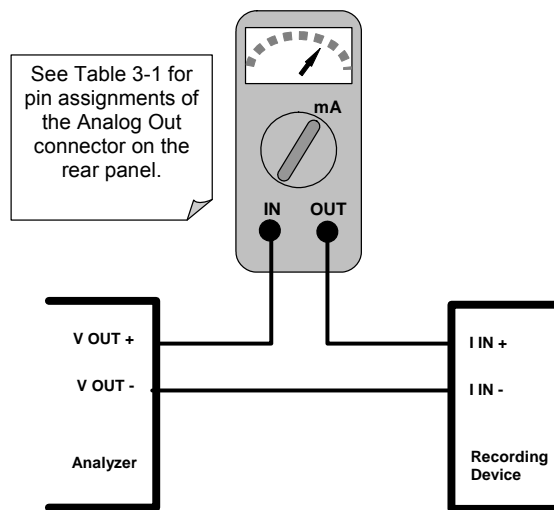
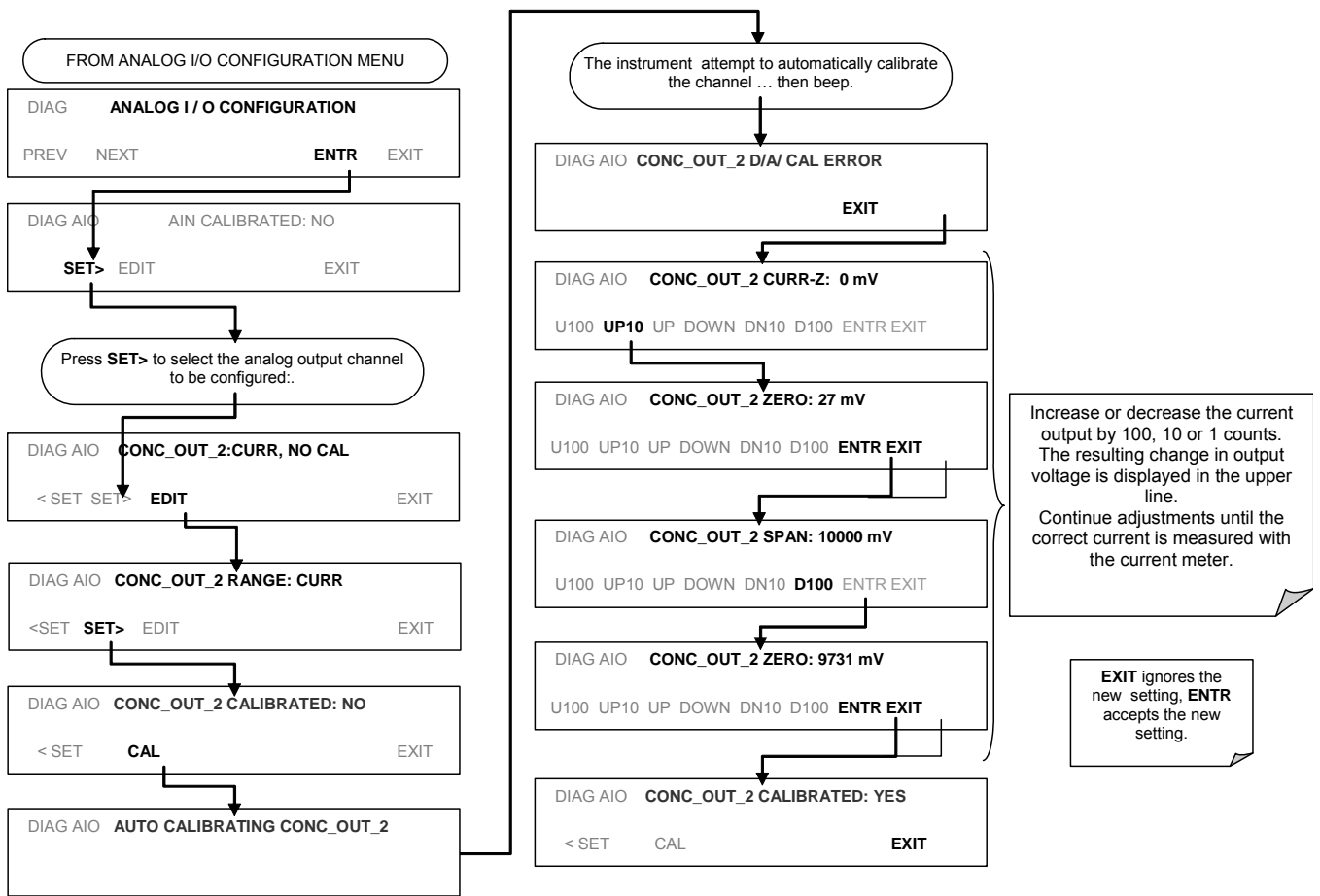

Figure 6-16: Setup for Calibrating Current Outputs

NOTE

Do not exceed 60 V between current loop outputs and instrument ground.

To adjust the zero and span values of the current outputs, activate the ANALOG I/O CONFIGURATION MENU (See Section 6.13.1), then press:



If a current meter is not available, an alternative method for calibrating the current loop outputs is to connect a 250 Ω ± 1% resistor across the current loop output. Using a voltmeter connected across the resistor, follow the procedure above but adjust the output to the following values:

Table 6-21: Current Loop Output Calibration with Resistor

Full scale	Voltage for 2-20 mA (measured across resistor)	Voltage for 4-20 mA (measured across resistor)
0%	0.5 V	1.0 V
100%	5.0 V	5.0 V

6.13.4.5. AIN Calibration

This is the sub-menu to conduct the analog input calibration. This calibration should only be necessary after major repair such as a replacement of CPU, motherboard or power supplies. Activate the ANALOG I/O CONFIGURATION MENU (See Section 6.13.1), then press:

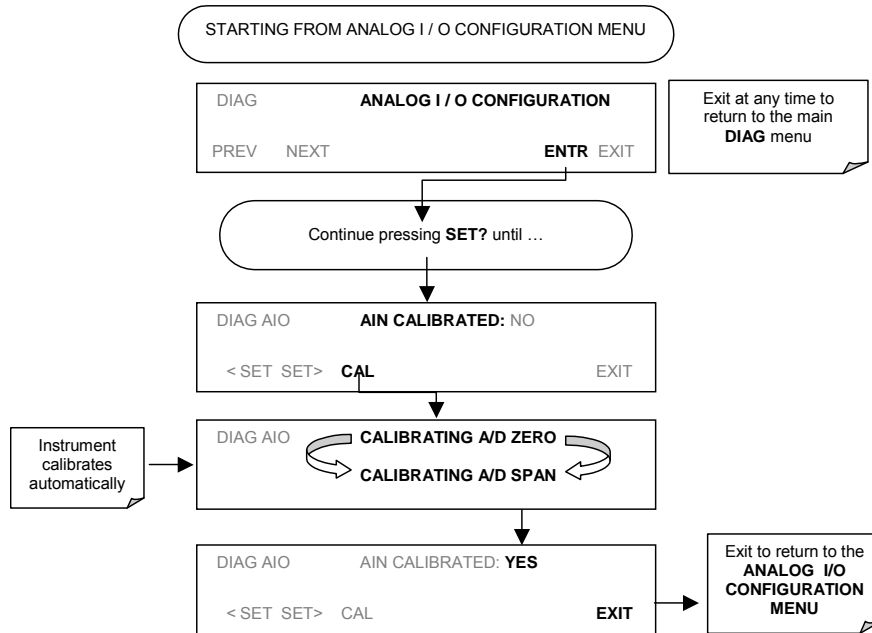

6.13.5. Electric Test

The electric test function substitutes simulated signals for **CO₂ MEAS** and **CO₂ REF**, generated by circuitry on the sync/demod board, for the output of the IR photo-detector. While in this mode the user can also view the same test functions viewable from the main **SAMPLE** display. When the test is running, the concentration reported on the front panel display should be **40.0** ppm.

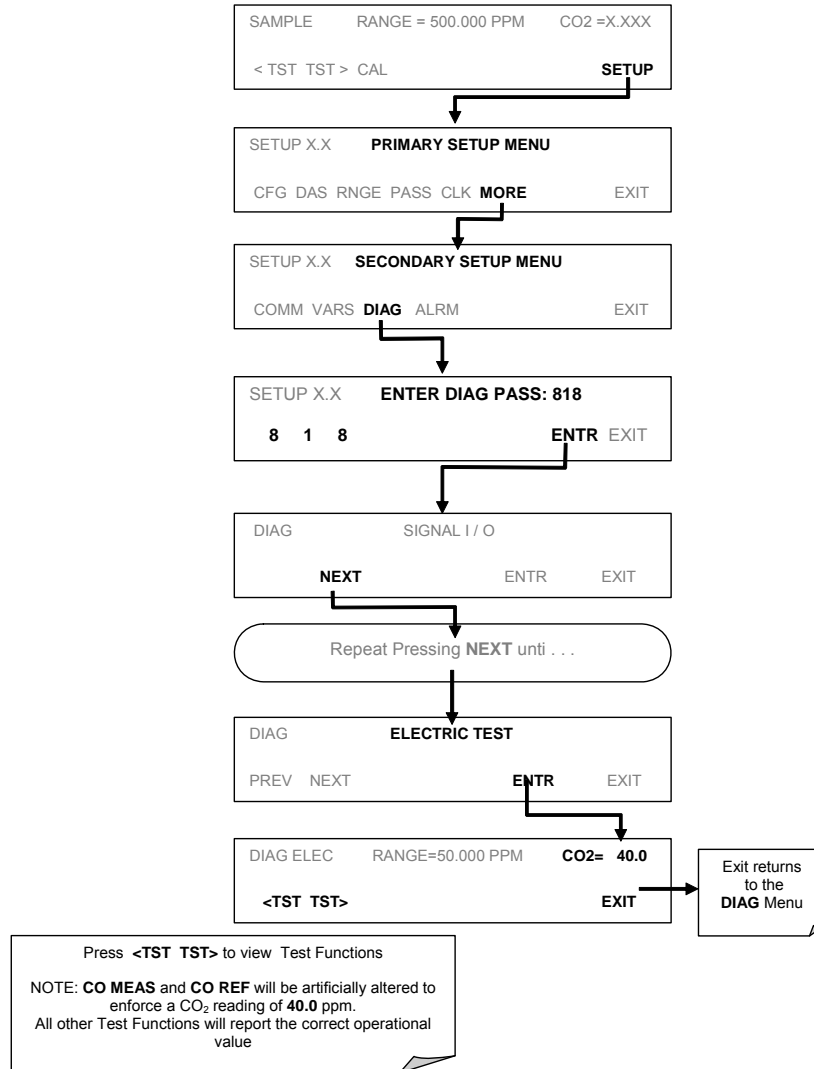

6.13.6. Dark Calibration Test

The dark calibration test interrupts the signal path between the IR photo-detector and the remainder of the sync/demod board circuitry. This allows the instrument to compensate for any voltage levels inherent in the sync/demod circuitry that might effect the calculation of CO₂ concentration. Performing this calibration returns two offset voltages, One for CO₂ MEAS and on for CO₂ REF that are automatically added to the CPU's calculation routine. The two offset voltages from the last calibration procedure may be reviewed by the user via the front panel display.

To activate the dark calibration procedure or review the results of a previous calibration, press:

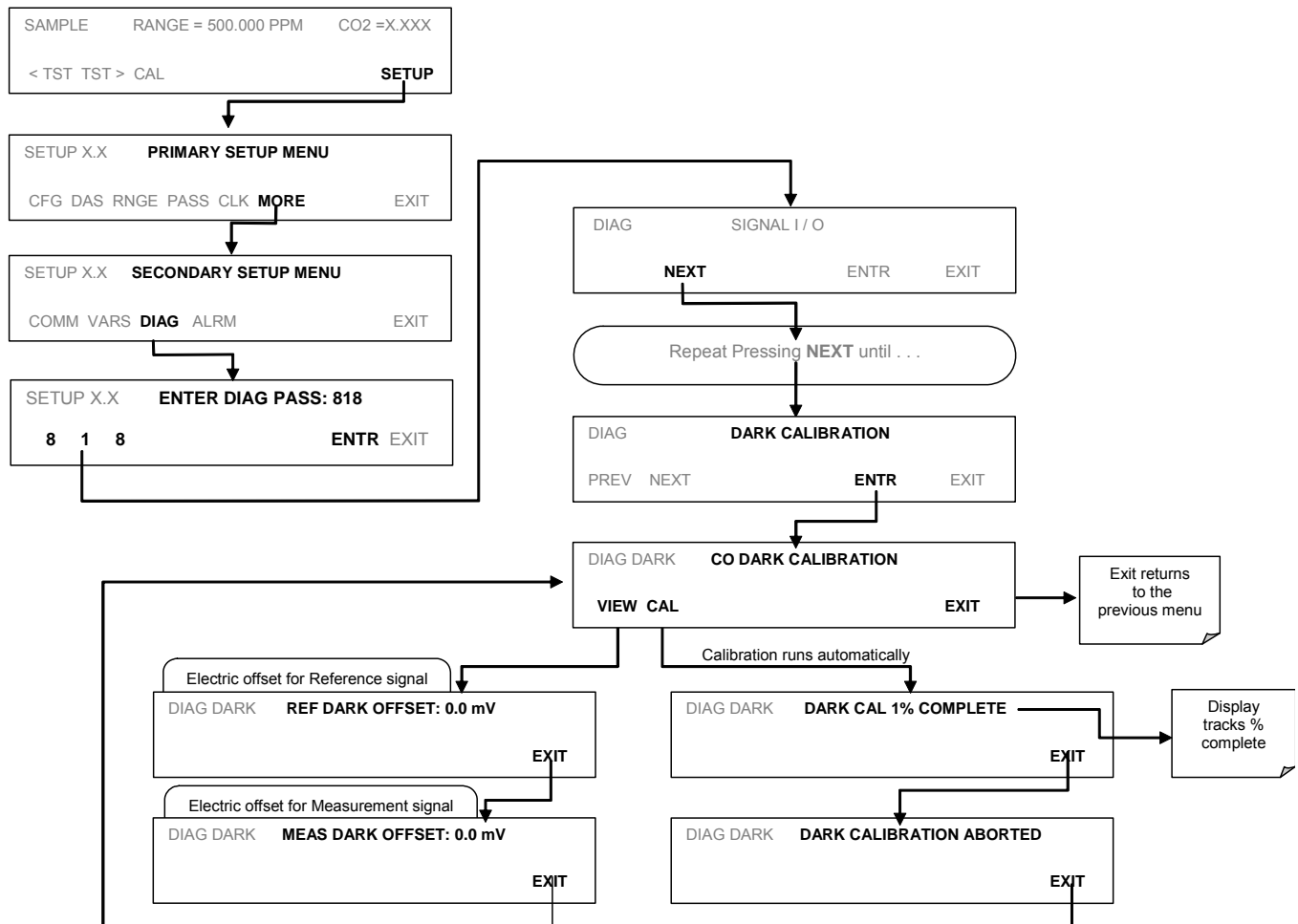

6.13.7. Pressure Calibration

A sensor at the exit of the sample chamber continuously measures the pressure of the sample gas. This data is used to compensate the final CO₂ concentration calculation for changes in atmospheric pressure and is stored in the CPU's memory as the test function **PRES** (also viewable via the front panel).

NOTE

This calibration must be performed when the pressure of the sample gas is equal to ambient atmospheric pressure.

Before performing the following pressure calibration procedure, disconnect the sample gas pump and the sample gas-line vent from the sample gas inlet on the instrument's rear panel.

To cause the analyzer to measure and record a value for **PRES**, press.

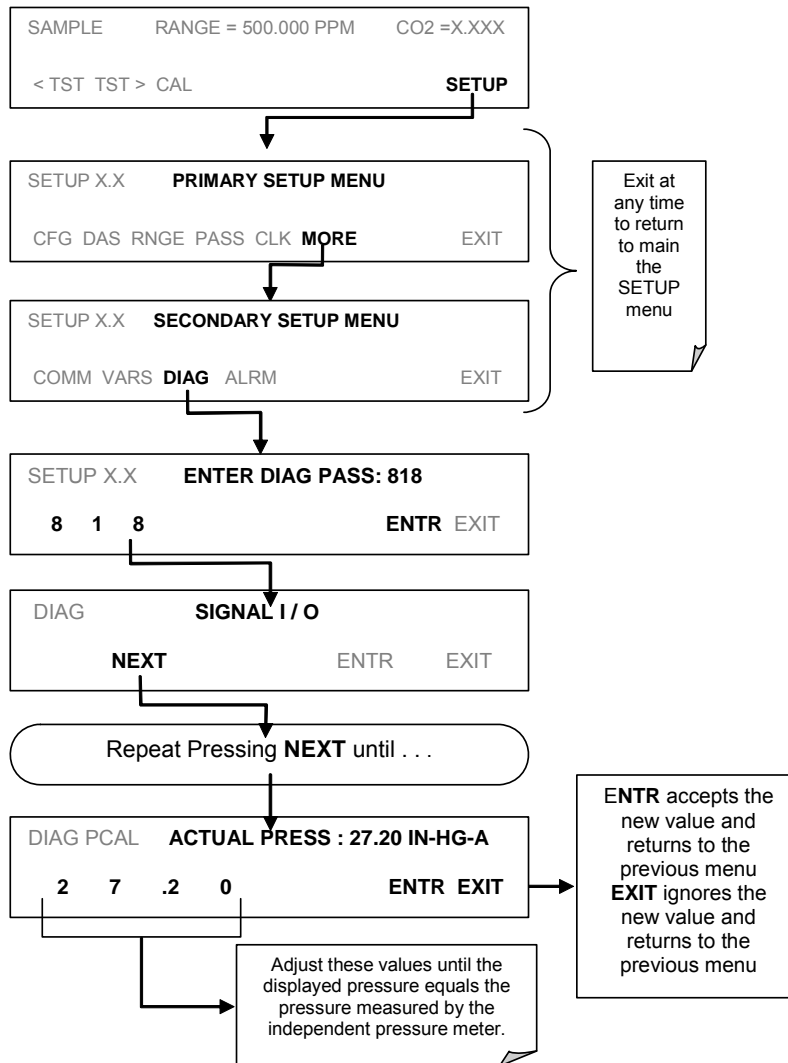

6.13.8. Flow Calibration

The flow calibration allows the user to adjust the values of the sample flow rates as they are displayed on the front panel and reported through COM ports to match the actual flow rate measured at the sample inlet. This does not change the hardware measurement of the flow sensors, only the software calculated values.

To carry out this adjustment, connect an external, sufficiently accurate flow meter to the sample inlet (see Chapter 11 for more details). Once the flow meter is attached and is measuring actual gas flow, press:

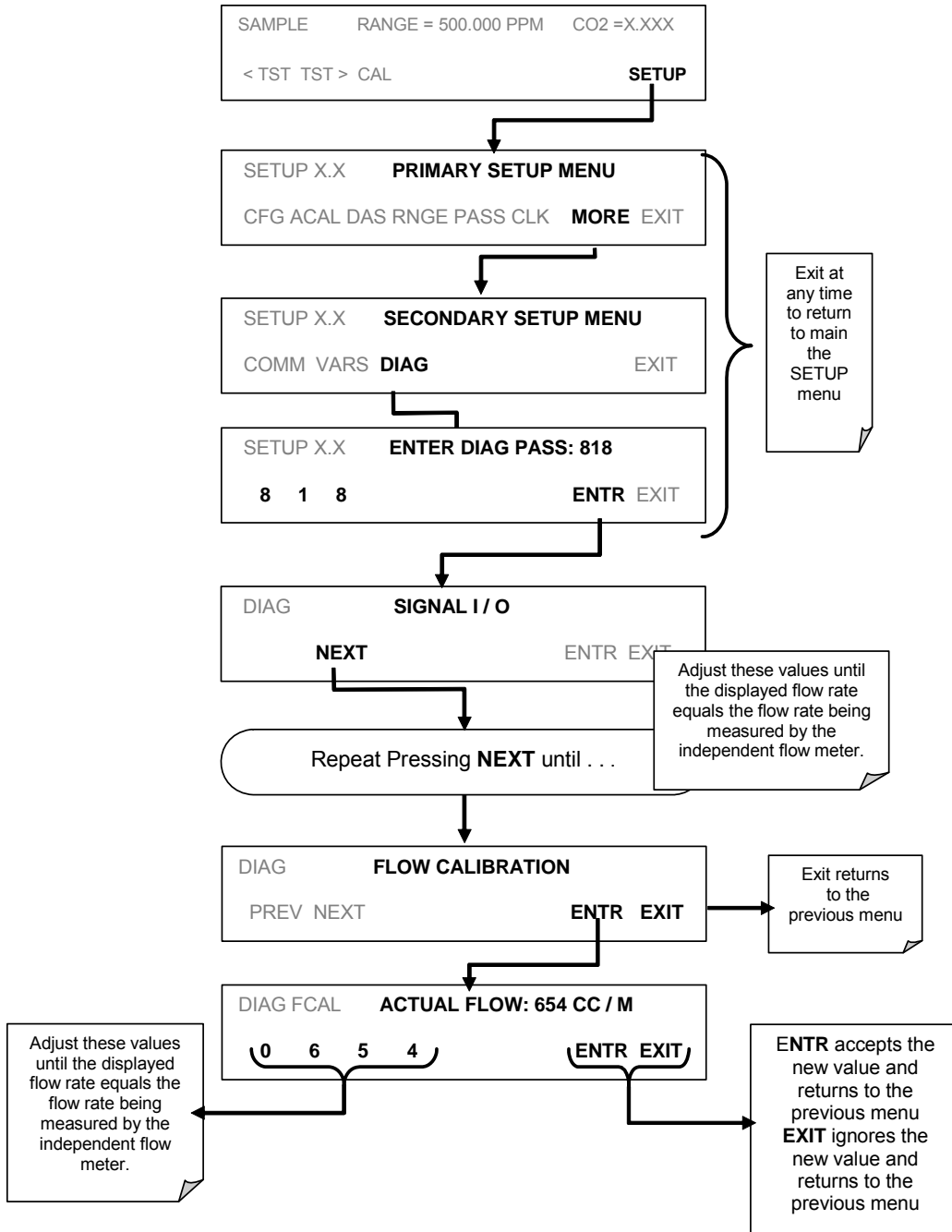

6.13.9. Test Channel Output

When activated, output channel **A4** can be used to report one of the test functions viewable from the SAMPLE mode display. To activate the **A4** channel and select a test function, follow this key sequence:

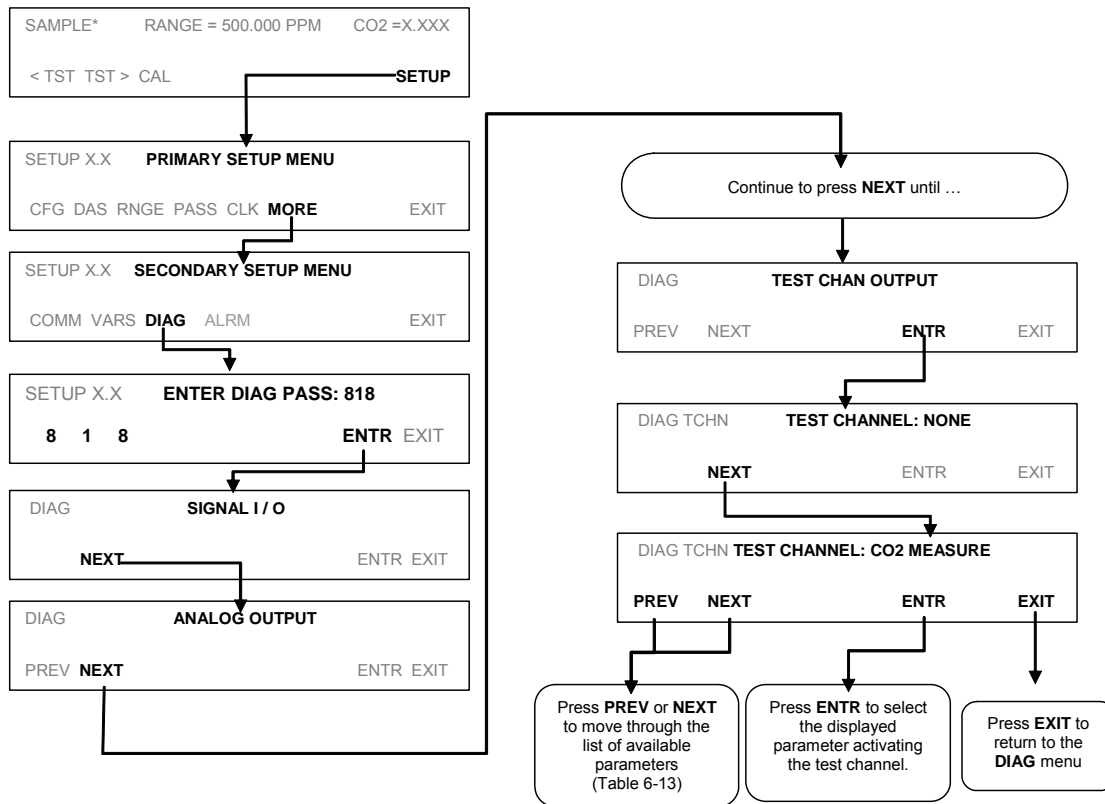

Table 6-22: Test Parameters Available for Analog Output A4

TEST CHANNEL	ZERO	FULL SCALE
NONE	Test Channel is turned off	
CO ₂ MEASURE	0 mV	5000 mV*
CO ₂ REFERENCE	0 mV	5000 mV*
SAMPLE PRESS	0 "Hg	40 "Hg
SAMPLE FLOW	0 cc/m	1000 cc/m
SAMPLE TEMP	0°C	70°C
BENCH TEMP	0°C	70°C
WHEEL TEMP	0°C	70°C
CHASSIS TEMP	0°C	70°C
PHT DRIVE	0 mV	5000 mV

* This refers to the internal voltage level of the function NOT the output signal level of the Test channel itself.

6.14. SETUP → MORE → ALRM: Using the Gas Concentration Alarms

The Model 360E includes two CO₂ concentration alarms. Each alarm has a user settable limit, and is associated with an opto-isolated TTL relay accessible via the status output connector on the instrument's back panel (See Section 6.15.1.1). If the CO₂ concentration measured by the instrument rises above that limit, the alarm's status output relay is closed.

The default settings for **ALM1** and **ALM2** are:

Table 6-23: CO₂ Concentration Alarm Default Settings

ALARM	STATUS	LIMIT SET POINT ¹
ALM1	Disabled	100 ppm
ALM2	Disabled	300 ppm

¹Set points listed are for PPM. Should the reporting range units of measure be changed (See Section 6.7.6) the analyzer will automatically scale the set points to match the new range unit setting.

Note

To prevent the concentration alarms from activating during span calibration operations make sure to press CAL or CALS button prior to introducing span gas into the analyzer.

6.14.1. Setting the Concentration Alarm Limits

To enable either of the CO₂ concentration alarms and set the Limit points, press:

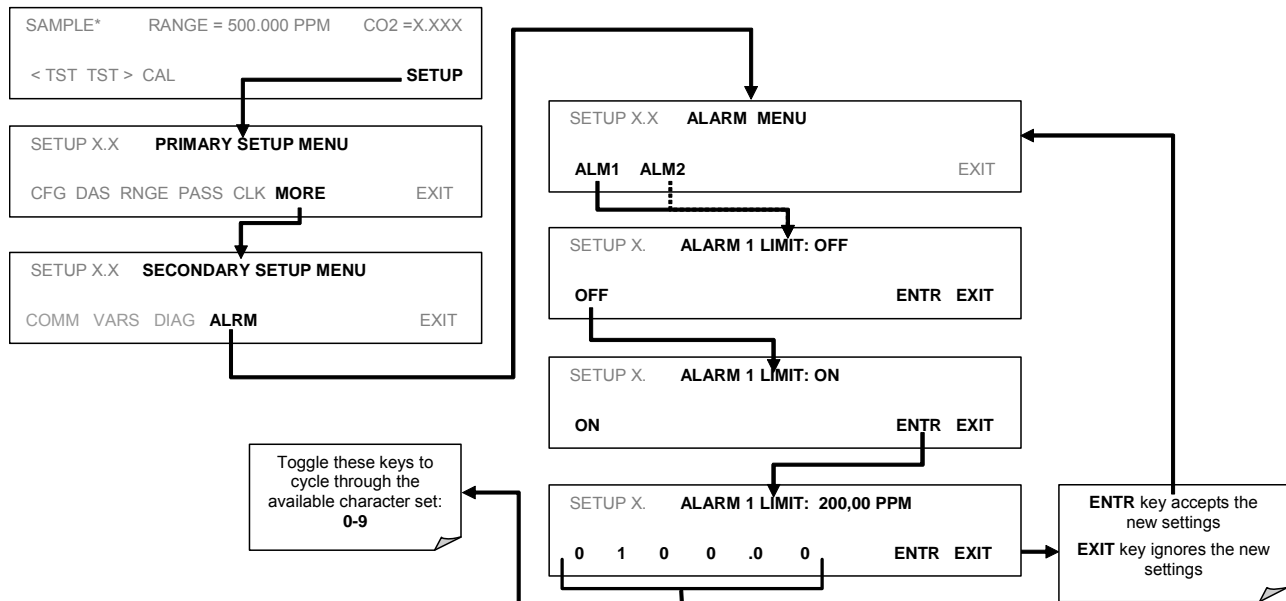

6.15. Remote Operation of the Analyzer

6.15.1. Remote Operation Using the External Digital I/O

6.15.1.1. Status Outputs

The status outputs report analyzer conditions via optically isolated NPN transistors, which sink up to 50 mA of DC current. These outputs can be used to interface with devices that accept logic-level digital inputs, such as programmable logic controllers (PLC's). Each Status bit is an open collector output that can withstand up to 40 VDC. All of the emitters of these transistors are tied together and available at D.

NOTE

Most PLC's have internal provisions for limiting the current that the input will draw from an external device. When connecting to a unit that does not have this feature, an external dropping resistor must be used to limit the current through the transistor output to less than 50 mA. At 50 mA, the transistor will drop approximately 1.2V from its collector to emitter.

The status outputs are accessed via a 12-pin connector on the analyzer's rear panel labeled STATUS. The function of each pin is defined in Table 6-24.

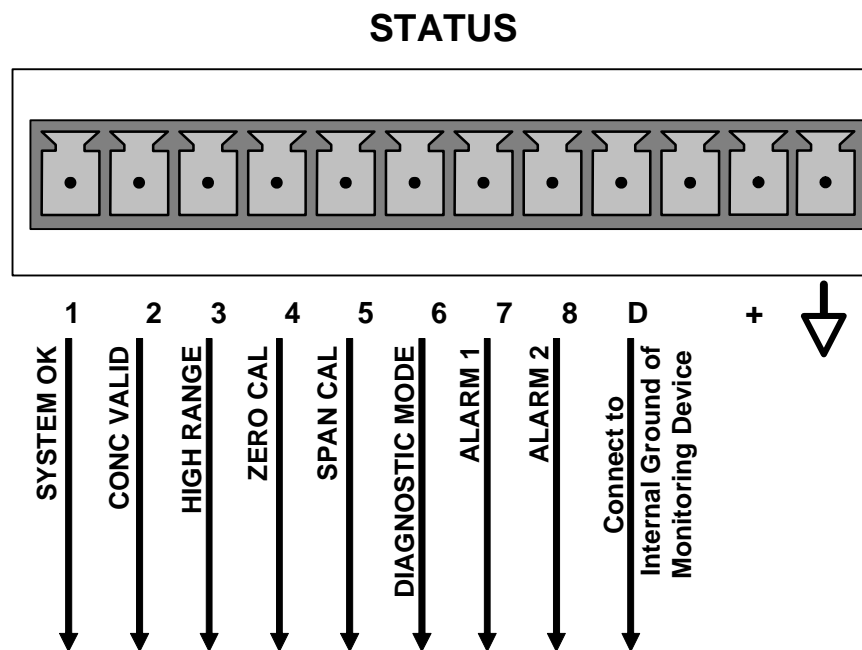



Figure 6-17: Status Output Connector

The pin assignments for the Status Outputs are:

Table 6-24: Status Output Pin Assignments

OUTPUT #	Status Definition	Condition
1	SYSTEM OK	On if no faults are present.
2	CONC VALID	On if CO ₂ concentration measurement is valid. If the CO ₂ concentration measurement is invalid, this bit is OFF.
3	HIGH RANGE	On if unit is in high range of DUAL or AUTO range modes.
4	ZERO CAL	On whenever the instruments zero point is being calibrated.
5	SPAN CAL	On whenever the instruments span point is being calibrated.
6	DIAG MODE	On whenever the instrument is in diagnostic mode.
7	ALARM1	On whenever the measured CO ₂ concentration is above the set point for ALM1
8	ALARM2	On whenever the measured CO ₂ concentration is above the set point for ALM2
D	EMITTER BUSS	The emitters of the transistors on pins 1-8 are bussed together.
+	DC POWER	+ 5 VDC
	Digital Ground	The ground level from the analyzer's internal DC power supplies.

6.15.1.2. Control Inputs

These inputs allow the user to remotely initiate Zero and Span calibrations. Two methods for energizing the inputs is provided below; the first using the internal +5V available on the CONTROL IN connector and the second, if an external, isolated supply is employed.

Table 6-25: Control Input Pin Assignments

INPUT	STATUS	CONDITION WHEN ENABLED
A	EXTERNAL ZERO CAL	Zero calibration mode is activated. The mode field of the display will read ZERO CAL R.
B	EXTERNAL SPAN CAL	Span calibration mode is activated. The mode field of the display will read SPAN CAL R.
C		Unused
D		Unused
E		Unused
F		Unused
⏚	DIGITAL GROUND	Provided to ground an external device (e.g., recorder).
U	DC power for Input pull ups	Input for +5 VDC required to activate inputs A - F. This voltage can be taken from an external source or from the "+" pin.
+	Internal +5V Supply	Internal source of +5V which can be used to activate inputs when connected to pin U.

There are two methods to activate control inputs. The internal +5V available from the "+" pin is the most convenient method (Figure 6-18). However, to ensure that these inputs are truly isolated, a separate, external 5 VDC power supply should be used.

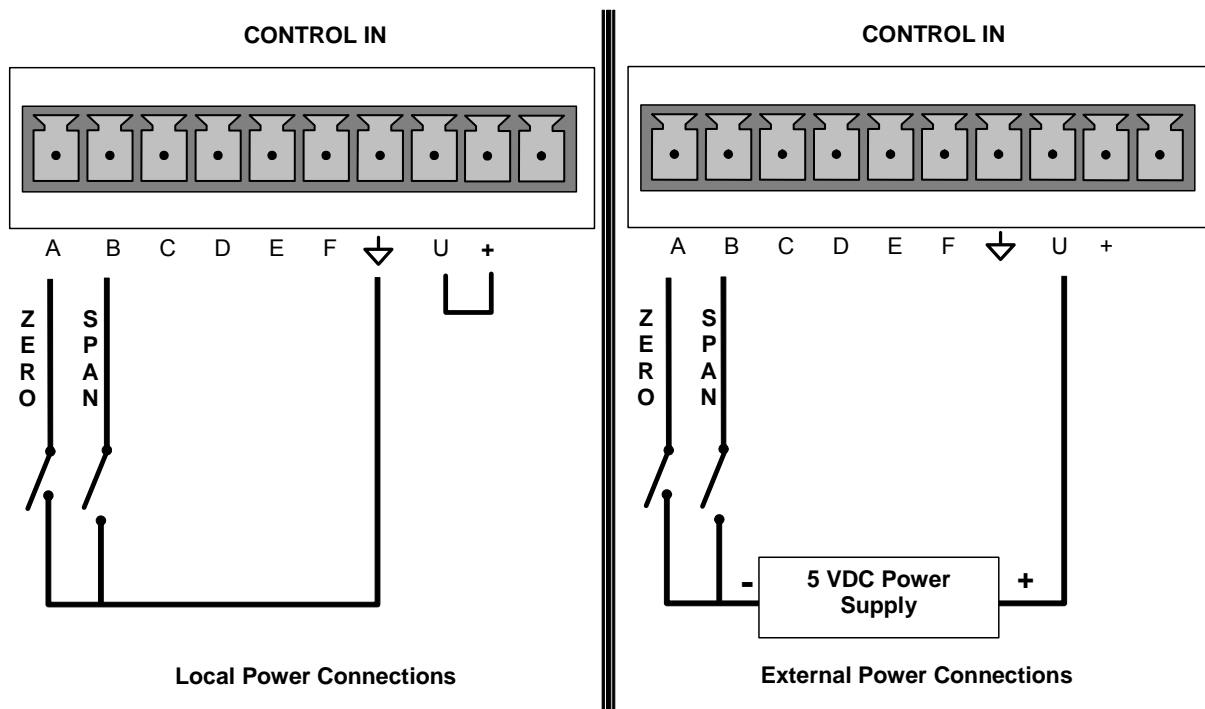

Figure 6-18: Control Inputs

6.15.2. Remote Operation Using the External Serial I/O

6.15.2.1. Terminal Operating Modes

The Model 360E can be remotely configured, calibrated or queried for stored data through the serial ports. As terminals and computers use different communication schemes, the analyzer supports two communicate modes specifically designed to interface with these two types of devices.

- **Computer mode** is used when the analyzer is connected to a computer with a dedicated interface program such as APICOM. More information regarding APICOM can be found in later in this or on the Teledyne Instruments website at <http://www.teledyne-api.com/software/apicom/>.
- **Interactive mode** is used with a terminal emulation programs such as HyperTerminal or a “dumb” computer terminal. The commands that are used to operate the analyzer in this mode are listed in Table 6-26.

6.15.2.2. Help Commands in Terminal Mode

Table 6-26: Terminal Mode Software Commands

COMMAND	Function
Control-T	Switches the analyzer to terminal mode (echo, edit). If mode flags 1 & 2 are OFF, the interface can be used in interactive mode with a terminal emulation program.
Control-C	Switches the analyzer to computer mode (no echo, no edit).
CR (carriage return)	A carriage return is required after each command line is typed into the terminal/computer. The command will not be sent to the analyzer to be executed until this is done. On personal computers, this is achieved by pressing the ENTER key.
BS (backspace)	Erases one character to the left of the cursor location.
ESC (escape)	Erases the entire command line.
? [ID] CR	This command prints a complete list of available commands along with the definitions of their functionality to the display device of the terminal or computer being used. The ID number of the analyzer is only necessary if multiple analyzers are on the same communications line, such as the multi-drop setup.
Control-C	Pauses the listing of commands.
Control-P	Restarts the listing of commands.

6.15.2.3. Command Syntax

Commands are not case-sensitive and all arguments within one command (i.e. ID numbers, keywords, data values, etc.) must be separated with a space character.

All Commands follow the syntax:

X [ID] COMMAND <CR>

Where

- X** is the command type (one letter) that defines the type of command. Allowed designators are listed in Table 6-27 and Appendix A-6.
- [ID]** is the analyzer identification number (Section 6.11.1.). Example: the Command “? 200” followed by a carriage return would print the list of available commands for the revision of software currently installed in the instrument assigned ID Number 200.
- COMMAND** is the command designator: This string is the name of the command being issued (LIST, ABORT, NAME, EXIT, etc.). Some commands may have additional arguments that define how the command is to be executed. Press ? <CR> or refer to Appendix A-6 for a list of available command designators.
- <CR>** is a carriage return. All commands must be terminated by a carriage return (usually achieved by pressing the ENTER key on a computer).

Table 6-27: Command Types

COMMAND	COMMAND TYPE
C	Calibration
D	Diagnostic
L	Logon
T	Test measurement
V	Variable
W	Warning

6.15.2.4. Data Types

Data types consist of integers, hexadecimal integers, floating-point numbers, Boolean expressions and text strings.

- Integer data are used to indicate integral quantities such as a number of records, a filter length, etc. They consist of an optional plus or minus sign, followed by one or more digits. For example, +1, -12, 123 are all valid integers.
- Hexadecimal integer data are used for the same purposes as integers. They consist of the two characters “0x,” followed by one or more hexadecimal digits (0-9, A-F, a-f), which is the ‘C’ programming language convention. No plus or minus sign is permitted. For example, 0x1, 0x12, 0x1234abcd are all valid hexadecimal integers.
- Floating point numbers are used to specify continuously variable values such as temperature set points, time intervals, warning limits, voltages, etc. They consist of an optional plus or minus sign, followed by zero or more digits, an optional decimal point, and zero or more digits. (At least one digit must appear before or after the decimal point.) Scientific notation is not permitted. For example, +1.0, 1234.5678, -0.1, 1 are all valid floating-point numbers.

- Boolean expressions are used to specify the value of variables or I/O signals that may assume only two values. They are denoted by the keywords *ON* and *OFF*.
- Text strings are used to represent data that cannot be easily represented by other data types, such as data channel names, which may contain letters and numbers. They consist of a quotation mark, followed by one or more printable characters, including spaces, letters, numbers, and symbols, and a final quotation mark. For example, "a", "1", "123abc", and "()*<>*" are all valid text strings. It is not possible to include a quotation mark character within a text string.
- Some commands allow you to access variables, messages, and other items, such as iDAS data channels, by name. When using these commands, you must type the entire name of the item; you cannot abbreviate any names.

6.15.2.5. Status Reporting

Reporting of status messages as an audit trail is one of the three principal uses for the RS-232 interface (the other two being the command line interface for controlling the instrument and the download of data in electronic format). You can effectively disable the reporting feature by setting the interface to quiet mode (Section 6.11.5., Table 6-10).

Status reports include iDAS data (when reporting is enabled), warning messages, calibration and diagnostic status messages. Refer to Appendix A-3 for a list of the possible messages, and this for information on controlling the instrument through the RS-232 interface.

General Message Format

All messages from the instrument (including those in response to a command line request) are in the format:

X DDD:HH:MM [Id] MESSAGE<CRLF>

Where:

- | | |
|-----------|--|
| X | is a command type designator, a single character indicating the message type, as shown in the Table 6-27. |
| DDD:HH:MM | is the time stamp, the date and time when the message was issued. It consists of the Day-of-year (DDD) as a number from 1 to 366, the hour of the day (HH) as a number from 00 to 23, and the minute (MM) as a number from 00 to 59. |
| [ID] | is the analyzer ID, a number with 1 to 4 digits. |
| MESSAGE | is the message content that may contain warning messages, test measurements, iDAS reports, variable values, etc. |
| <CRLF> | is a carriage return / line feed pair, which terminates the message. |

The uniform nature of the output messages makes it easy for a host computer to parse them into an easy structure. Keep in mind that the front panel display does not give any information on the time a message was issued, hence it is useful to log such messages for trouble-shooting and reference purposes. Terminal emulation programs such as HyperTerminal can capture these messages to text files for later review.

6.15.2.6. Remote Access by Modem

The M360E can be connected to a modem for remote access. This requires a cable between the analyzer's COM port and the modem, typically a DB-9F to DB-25M cable (available from Teledyne Instruments with part number WR0000024).

Once the cable has been connected, check to make sure the DTE-DCE is in the correct position. Also make sure the M360E COM port is set for a baud rate that is compatible with the modem, which needs to operate with an 8-bit word length with one stop bit.

The first step is to turn on the **MODEM ENABLE** communication mode (Mode 64, Section 6.11.5). Once this is completed, the appropriate setup command line for your modem can be entered into the analyzer. The default setting for this feature is

```
AT Y0 &D0 &H0 &I0 S0=2 &B0 &N6 &M0 E0 Q1 &W0
```

This string can be altered to match your modem's initialization and can be up to 100 characters long.

To change this setting press:

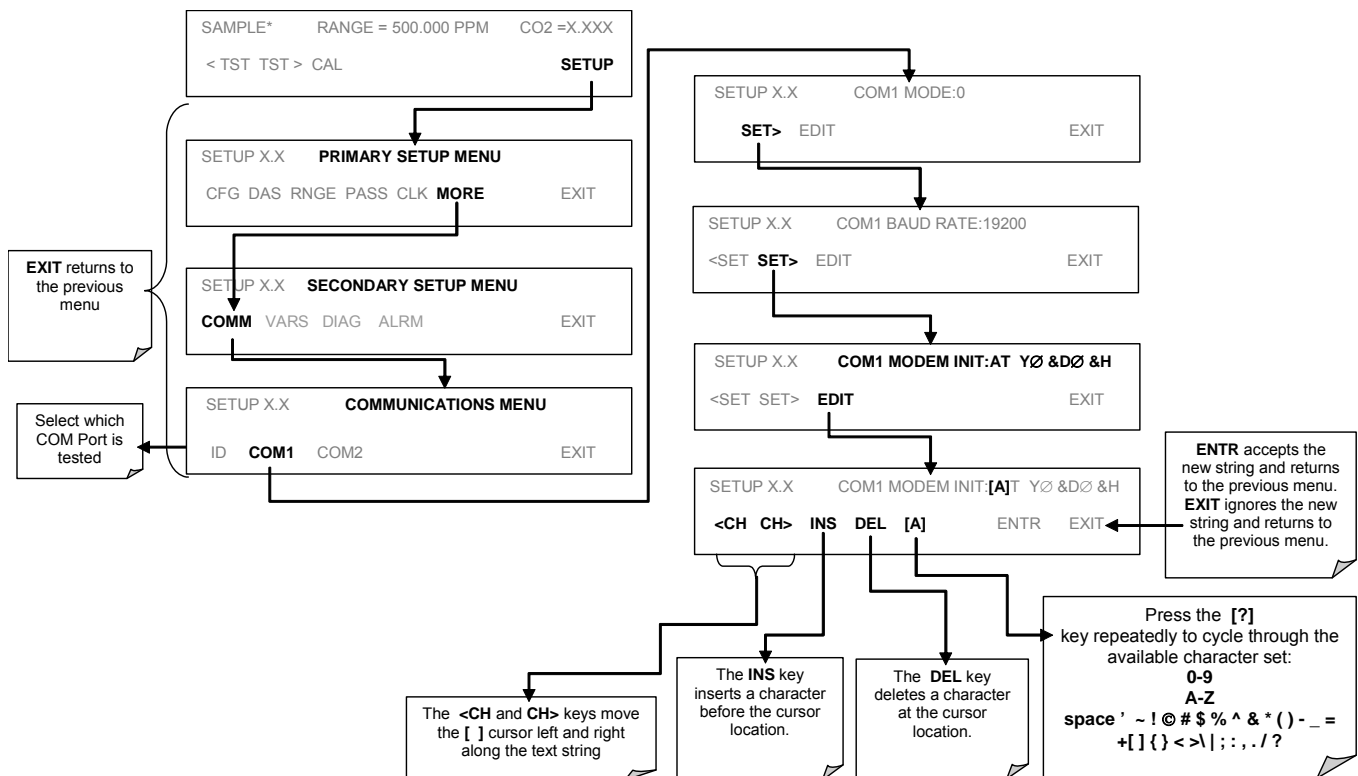

To initialize the modem press:

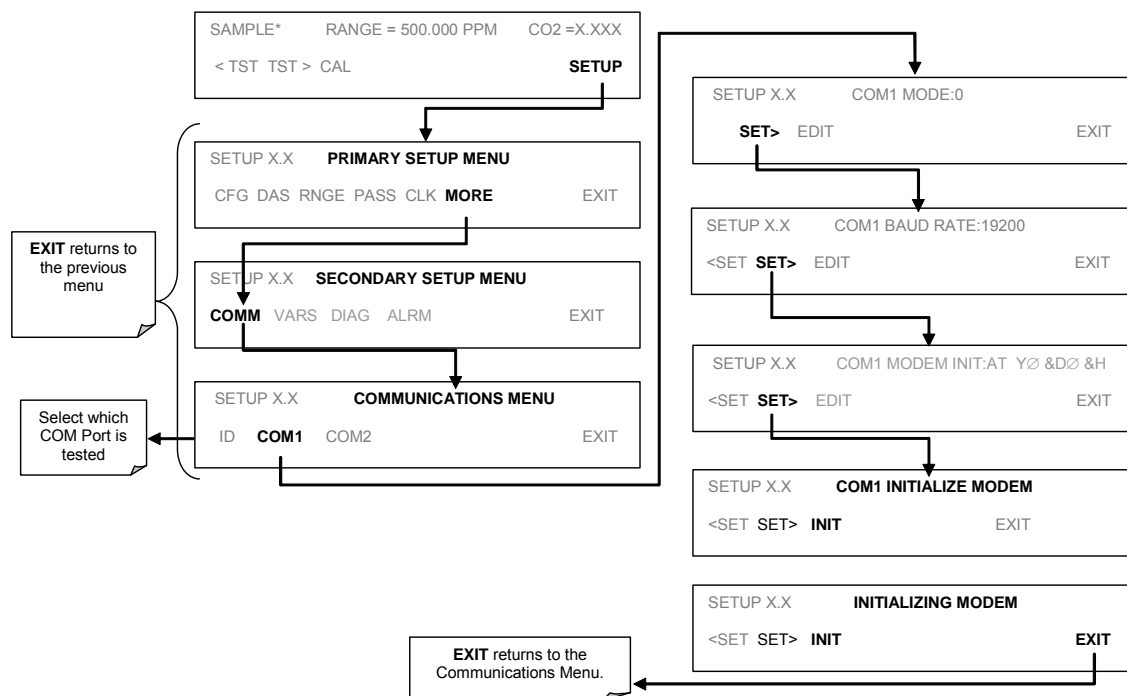

6.15.2.7. COM Port Password Security

In order to provide security for remote access of the M360E, a LOGON feature can be enabled to require a password before the instrument will accept commands. This is done by turning on the **SECURITY MODE** (Mode 4, Section 6.11.5). Once the **SECURITY MODE** is enabled, the following items apply.

- A password is required before the port will respond or pass on commands.
- If the port is inactive for one hour, it will automatically logoff, which can also be achieved with the LOGOFF command.
- Three unsuccessful attempts to log on with an incorrect password will cause subsequent logins to be disabled for 1 hour, even if the correct password is used.
- If not logged on, the only active command is the '?' request for the help screen.
- The following messages will be returned at logon:
 - LOGON SUCCESSFUL - Correct password given
 - LOGON FAILED - Password not given or incorrect
 - LOGOFF SUCCESSFUL - Connection terminated successfully

To log on to the model 360E analyzer with **SECURITY MODE** feature enabled, type:

```
LOGON 940331
```

940331 is the default password. To change the default password, use the variable RS232_PASS issued as follows:

```
V RS232_PASS=NNNNNN
```

Where N is any numeral between 0 and 9.

6.15.2.8. APICOM Remote Control Program

APICOM is an easy-to-use, yet powerful interface program that allows accessing and controlling any of Teledyne Instruments' main line of ambient and stack-gas instruments from a remote connection through direct cable, modem or Ethernet. Running APICOM, a user can:

Establish a link from a remote location to the M360E through direct cable connection via RS-232 modem or Ethernet.

- View the instrument's front panel and remotely access all functions that could be accessed when standing in front of the instrument.
- Remotely edit system parameters and set points.
- Download, view, graph and save data for predictive diagnostics or data analysis.
- Retrieve, view, edit, save and upload iDAS configurations.
- Check on system parameters for trouble-shooting and quality control.

APICOM is very helpful for initial setup, data analysis, maintenance and trouble-shooting. Figure 6-5 shows an example of APICOM being used to remotely configuration the instruments iDAS feature. Figure 6-19 shows examples of APICOM's main interface, which emulates the look and functionality of the instruments actual front panel

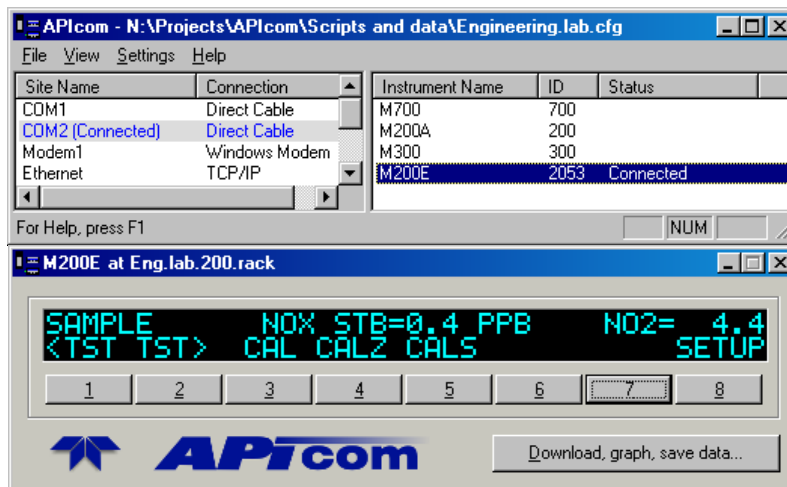

Figure 6-19: APICOM Remote Control Program Interface

APICOM is included free of cost with the analyzer and the latest versions can also be downloaded for free at <http://www.teledyne-api.com/software/apicom/>.

6.15.3. Additional Communications Documentation

Table 6-28: Serial Interface Documents

INTERFACE / TOOL	DOCUMENT TITLE	PART NUMBER	AVAILABLE ONLINE*
APICOM	APICOM User Manual	039450000	YES
Multi-drop	RS-232 Multi-drop Documentation	021790000	YES
DAS Manual	Detailed description of the iDAS.	028370000	YES

* These documents can be downloaded at <http://www.teledyne-api.com/manuals/>

6.15.4. Using the M360E with a Hessen Protocol Network

6.15.4.1. General Overview of Hessen Protocol

The Hessen protocol is a multidrop protocol, in which several remote instruments are connected via a common communications channel to a host computer. The remote instruments are regarded as slaves of the host computer. The remote instruments are unaware that they are connected to a multidrop bus and never initiate Hessen protocol messages. They only respond to commands from the host computer and only when they receive a command containing their own unique ID number.

The Hessen protocol is designed to accomplish two things: to obtain the status of remote instruments, including the concentrations of all the gases measured; and to place remote instruments into zero or span calibration or measure mode. API's implementation supports both of these principal features.

The Hessen protocol is not well defined, therefore while API's application is completely compatible with the protocol itself, it may be different from implementations by other companies.

The following subs describe the basics for setting up your instrument to operate over a Hessen Protocol network. For more detailed information as well as a list of host computer commands and examples of command and response message syntax, download the *Manual Addendum for Hessen Protocol* from the Teledyne Instruments web site: <http://www.teledyne-api.com/manuals/index.asp>.

6.15.4.2. Hessen COMM Port Configuration

Hessen protocol requires the communication parameters of the M360E's COMM ports to be set differently than the standard configuration as shown in the table below.

Table 6-29: RS-232 Communication Parameters for Hessen Protocol

Parameter	Standard	Hessen
Data Bits	8	7
Stop Bits	1	2
Parity	None	Even
Duplex	Full	Half

To change the rest of the COMM port parameters. See Section 6.11.5.

To change the baud rate of the M360E's COMM ports, See Section 6.11.8.

NOTE

Make sure that the communication parameters of the host computer are also properly set.

Also, the instrument software has a 200 ms. Latency before it responds to commands issued by the host computer. This latency should present no problems, but you should be aware of it and not issue commands to the instrument too frequently.

6.15.4.3. Activating Hessen Protocol

The first step in configuring the M360E to operate over a Hessen protocol network is to activate the Hessen mode for COMM ports and configure the communication parameters for the port(s) appropriately. Press:

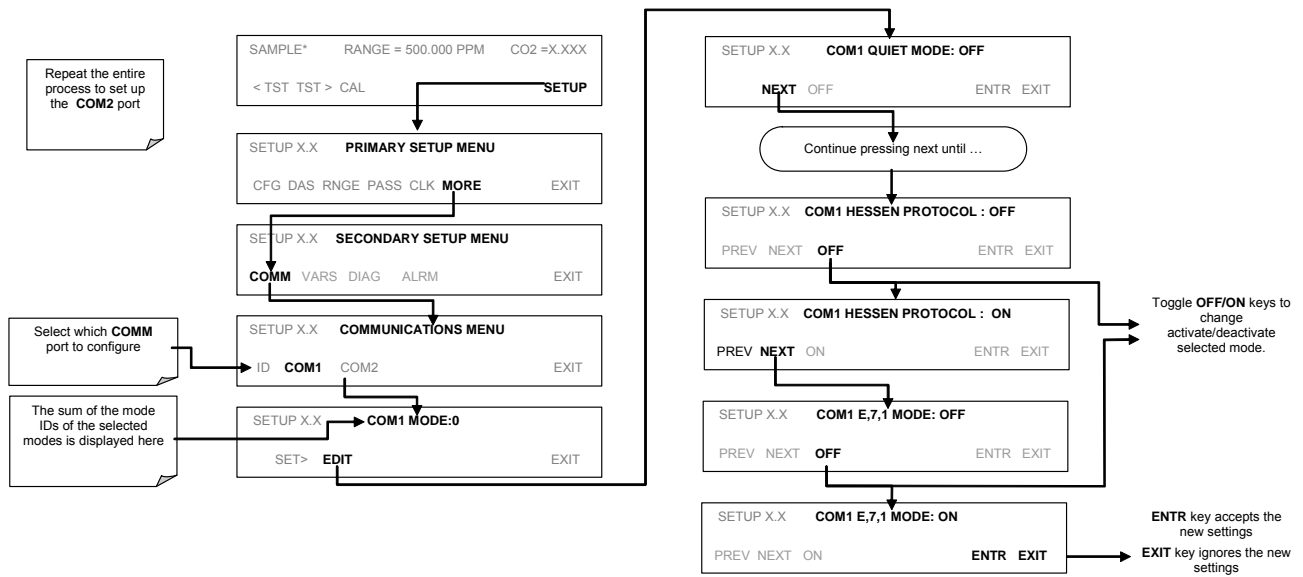

6.15.4.4. Selecting a Hessen Protocol Type

Currently there are two versions of Hessen Protocol in use. The original implementation, referred to as **TYPE 1**, and a more recently released version, **TYPE 2** that has more flexibility when operating with instruments that can measure more than one type of gas. For more specific information about the difference between **TYPE 1** and **TYPE 2** download the *Manual Addendum for Hessen Protocol* from the Teledyne Instruments web site: <http://www.teledyne-api.com/manuals/index.asp>.

To select a Hessen Protocol Type press:

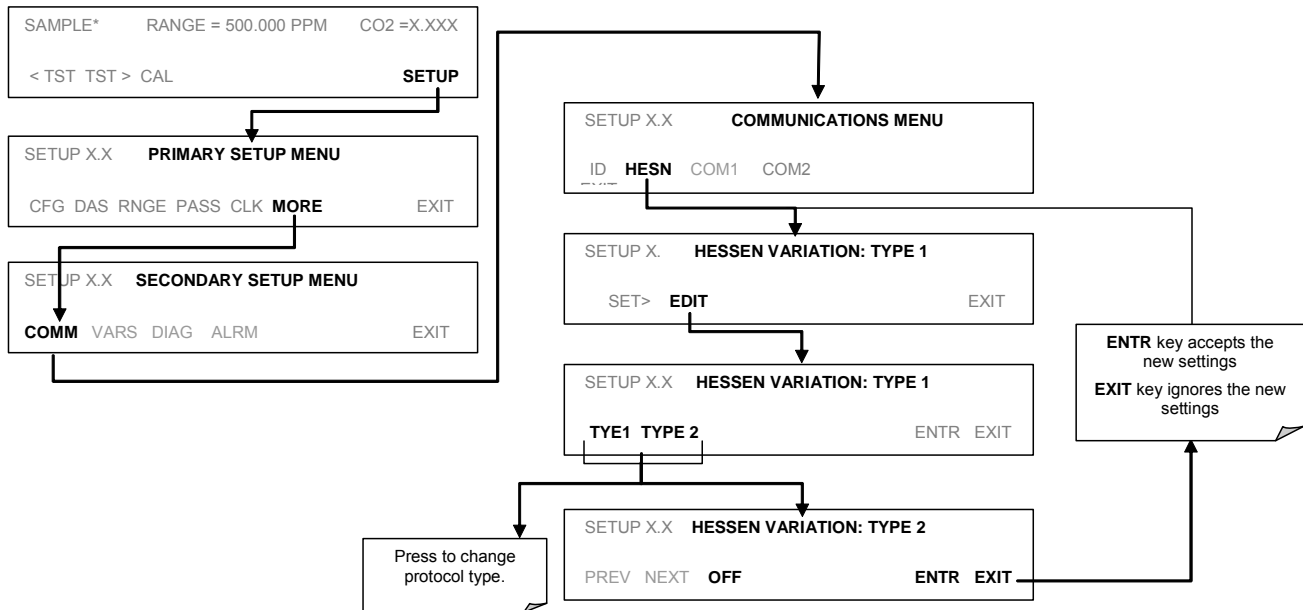

NOTE

While Hessen Protocol Mode can be activated independently for COM1 and COM2, The TYPE selection affects both Ports.

6.15.4.5. Setting The Hessen Protocol Response Mode

The Teledyne Instruments implementation of Hessen Protocol allows the user to choose one of several different modes of response for the analyzer.

Table 6-30: Teledyne Instruments Hessen Protocol Response Modes

MODE ID	MODE DESCRIPTION
CMD	This is the Default Setting. Responses from the instrument are encoded as the traditional command format. Style and format of responses depend on exact coding of the initiating command.
BCC	Responses from the instrument are always delimited with <STX> (at the beginning of the response, <ETX> (at the end of the response followed by a 2 digit Block Check Code (checksum), regardless of the command encoding.
TEXT	Responses from the instrument are always delimited with <CR> at the beginning and the end of the string, regardless of the command encoding.

To Select a Hessen response mode, press:

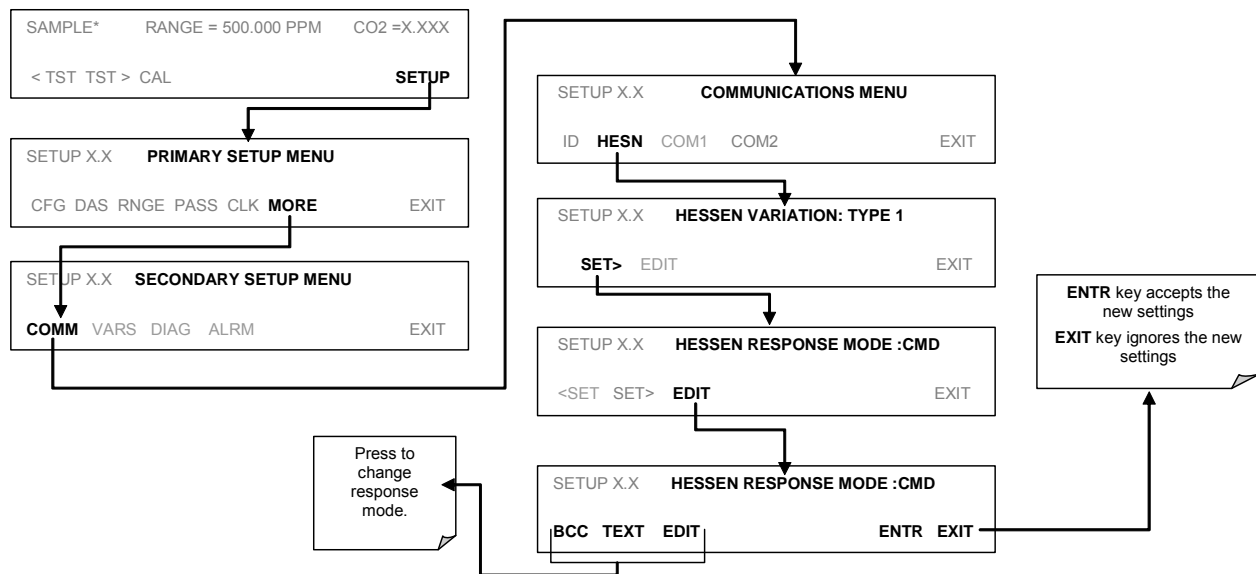

6.15.4.6. Hessen Protocol Gas ID

The Model 360E Analyzer is a single gas instrument that measures CO₂. As such it's default gas ID has already been set to **310**. There is no need to change this setting.

6.15.4.7. Setting Hessen Protocol Status Flags

Teledyne Instruments' implementation of Hessen protocols includes a set of status bits that the instrument includes in responses to inform the host computer of its condition. Each bit can be assigned to one operational and warning message flag. The default settings for these bit/flags are:

Table 6-31: Default Hessen Status Bit Assignments

STATUS FLAG NAME	DEFAULT BIT ASSIGNMENT
WARNING FLAGS	
SAMPLE FLOW WARNING	0001
BENCH TEMP WARNING	0002
SOURCE WARNING	0004
BOX TEMP WARNING	0008
WHEEL TEMP WARNING	0010
SAMPLE TEMP WARNING	0020
SAMPLE PRESSURE WARNING	0040
INVALID CONC (The Instrument's Front Panel Display Will Show The Concentration As "XXXX")	0080
OPERATIONAL FLAGS	
Instrument Off	0100
In Manual Calibration Mode	0200
In Zero Calibration Mode	0400
In Span Calibration Mode	0800
UNITS OF MEASURE FLAGS	
UGM	0000
MGM	2000
PPB	4000
PPM	6000
SPARE/UNUSED BITS	100, 1000, 8000
UNASSIGNED FLAGS (0000)	
Sync Warning	Relay Board Warning
Conc Alarm 1	Front Panel Warning
Conc Alarm 2	Analog Cal Warning
Photo Temp Warning	Cannot Dyn Zero
System Reset	Cannot Dyn Span
Rear Board Not Detected	Invalid Conc

NOTES:

It is possible to assign more than one flag to the same Hessen status bit. This allows the grouping of similar flags, such as all temperature warnings, under the same status bit.

Be careful not to assign conflicting flags to the same bit as each status bit will be triggered if any of the assigned flags is active.

To assign or reset the status flag bit assignments, press:

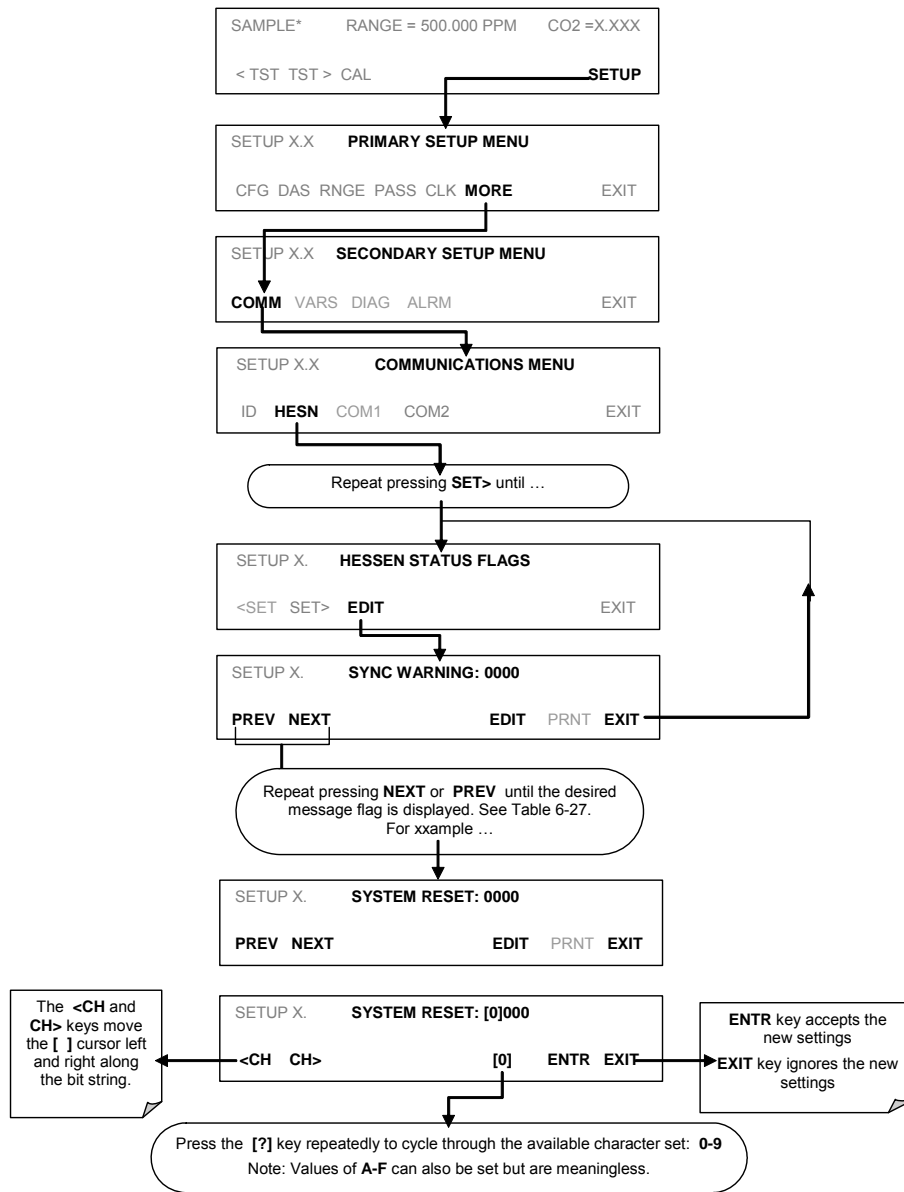

6.15.4.8. Instrument ID Code

Each instrument on a Hessen Protocol network must have a unique ID code. The M360E is programmed with a default ID code of 360. To change this code See Section 6.11.1

User Notes

7. CALIBRATION PROCEDURES

This contains a variety of information regarding the various methods for calibrating a Model 360E CO₂ Analyzer as well as other supporting information.

NOTE

The procedures in this assume that the calibration password feature is disabled (the instruments default state). If it is enabled a password prompt screen (See Section 6.9) will appear after the CAL, CALZ or CALS buttons are pushed but before the instrument enters the associated calibration mode.

7.1. Before Calibration

The calibration procedures in this assume that the Range Type, Range Span and units of measure have already been selected for the analyzer. If this has not been done, please do so before continuing (See Section 6.8 for instructions).

All Gas lines should be PTFE (Teflon), FEP, glass, stainless steel or brass.

NOTE

If any problems occur while performing the following calibration procedures, refer to Chapter 11 of this manual for troubleshooting tips.

7.1.1. Zero Air and Span Gas

To perform the following calibration you must have sources for zero air and span gas available.

Zero Air is similar in chemical composition to the Earth's atmosphere but scrubbed of all components that might affect the analyzer's readings. Zero air should contain less than 25 ppb of CO₂ and other major interfering gases such as CO and Water Vapor. It should have a dew point of -5°C or less

Span Gas is a gas specifically mixed to match the chemical composition of the type of gas being measured at near full scale of the desired measurement range. It is recommended that the span gas used have a concentration equal to 80% of the full measurement range.

If Span Gas is sourced directly from a calibrated, pressurized tank, the gas mixture should be CO₂ mixed with Zero Air or N₂ at the required ratio.

Zero air generators that condition ambient air by drying and removal of pollutants are available on the commercial market such as the Teledyne Instruments Model 701 Zero Air Generator. We recommend this type of device, in conjunction with a CO₂ scrubber such as soda lime (such as Teledyne Instruments P/N 037600000), for generating zero air.

7.1.2. Calibration Gas Traceability

All equipment used to produce calibration gases should be verified against standards of the National Institute for Standards and Technology (NIST). To ensure NIST traceability, we recommend acquiring cylinders of working gas that are certified to be traceable to NIST Standard Reference Materials (SRM). These are available from a variety of commercial sources.

7.1.3. Data Recording Devices

A strip chart recorder, data acquisition system or digital data acquisition system should be used to record data from the M360E's serial or analog outputs. If analog readings are used, the response of the recording system should be checked against a NIST traceable voltage source or meter. Data recording device should be capable of bi-polar operation so that negative readings can be recorded. For electronic data recording, the M360E provides an internal data acquisition system (iDAS), which is described in detail in Section 6.7.

7.2. Manual Calibration without Zero/Span Valves

This is the basic method for manually calibrating the Model 360E CO₂ Analyzer without functioning zero/span valve options. It is identical to the method described in the GETTING STARTED (Chapter 3) of this manual and is repeated here for your convenience.

STEP ONE: Connect the Sources of Zero Air and Span Gas as shown below.

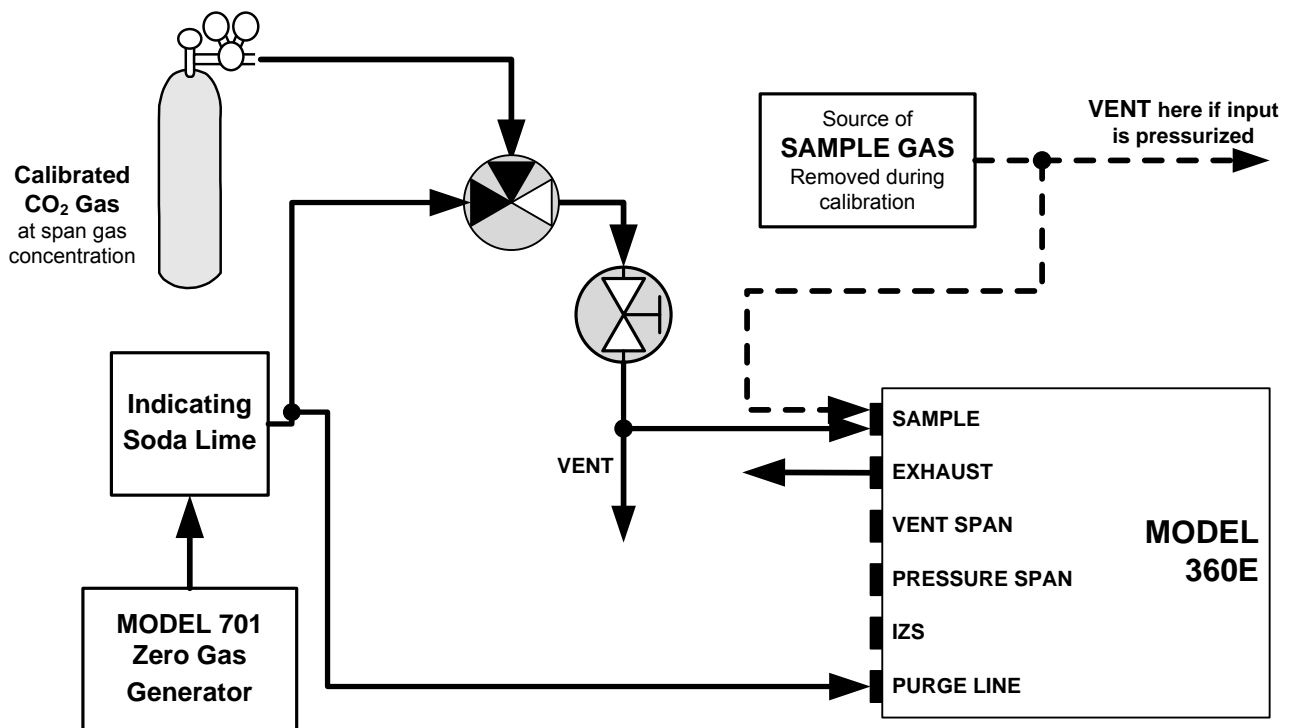

Figure 7-1: Pneumatic Connections—Basic Configuration—Using Bottled Span Gas

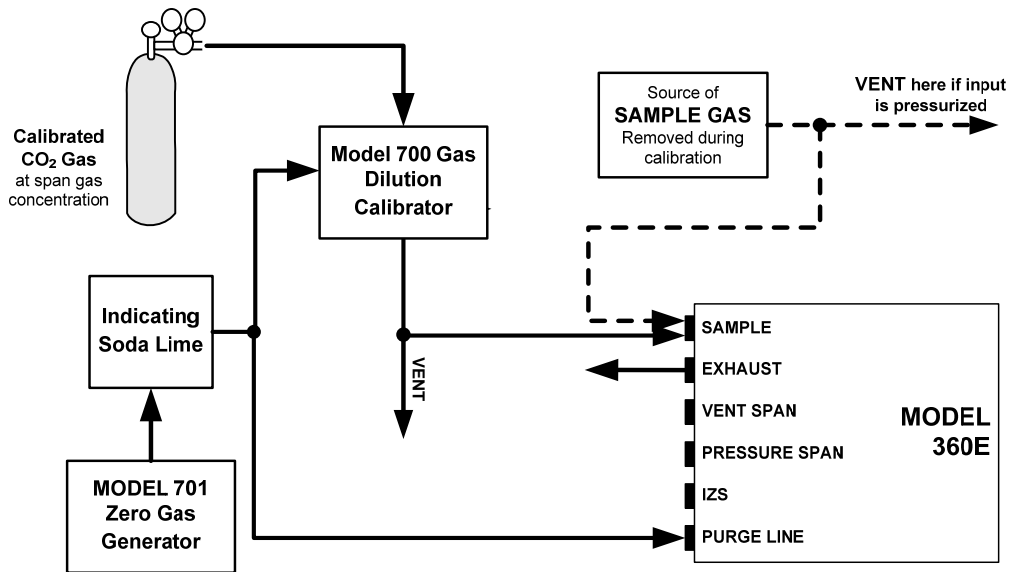
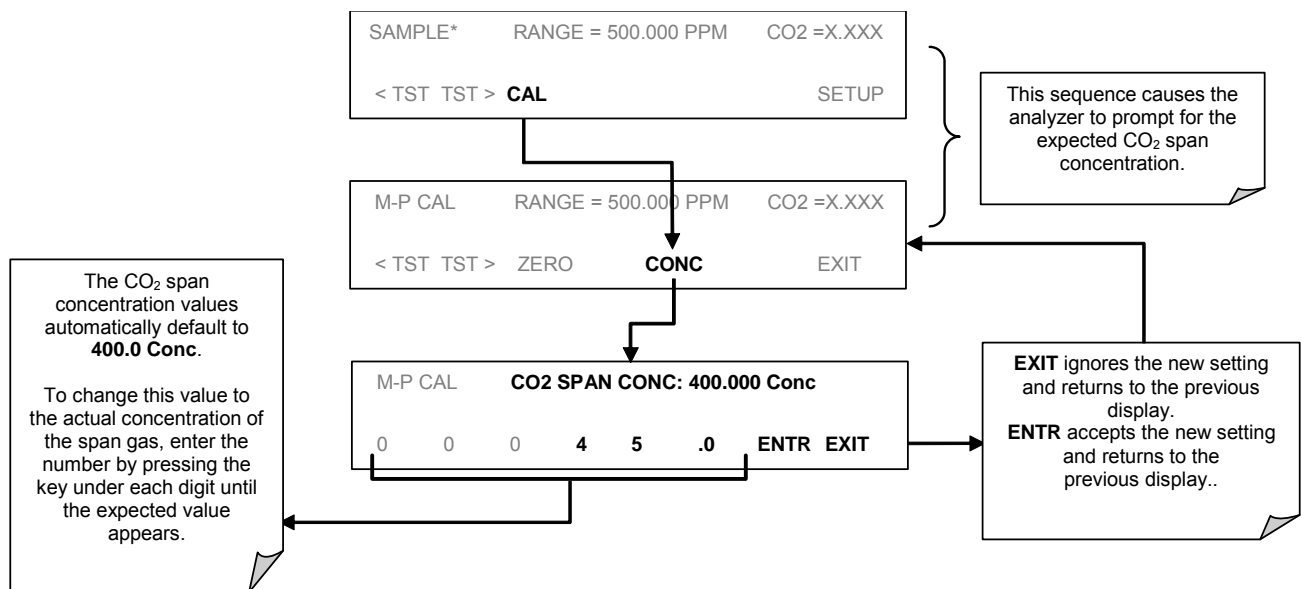

Figure 7-2: Pneumatic Connections–Basic Configuration–Using Gas Dilution Calibrator

STEP TWO: Set the expected CO₂ Span Gas concentration:



NOTE

For this Initial Calibration it is important to independently verify the PRECISE CO₂ Concentration Value of the SPAN gas.
If the source of the Span Gas is from a Calibrated Bottle, use the exact concentration value printed on the bottle.

STEP THREE: Perform the Zero/Span Calibration Procedure:

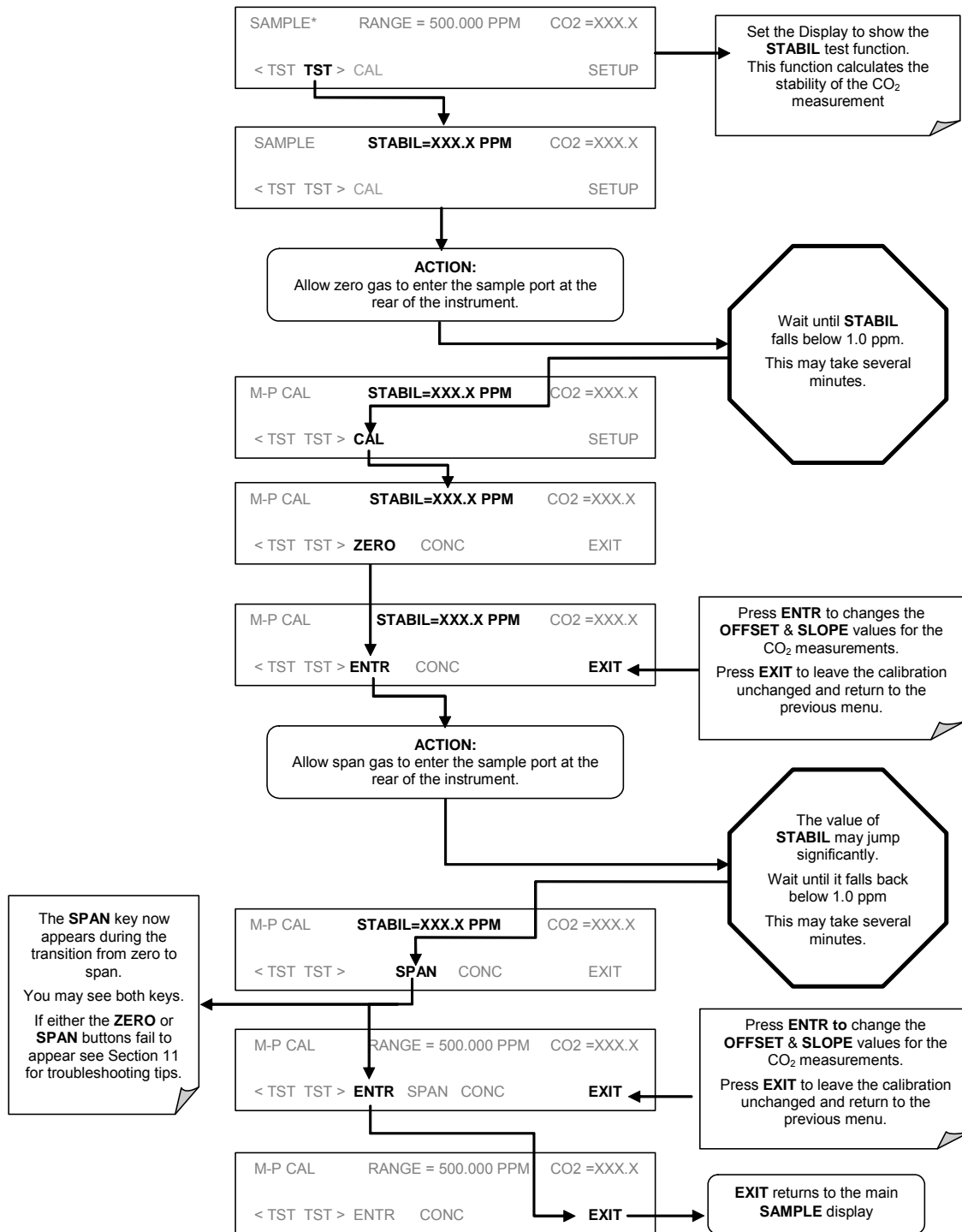

If the **ZERO** or **SPAN** keys are not displayed, this means that the measurement made during that part of the procedure is too far out of the allowable range to do allow a reliable calibration. The reason for this must be determined before the analyzer can be calibrated. See Chapter 11 for troubleshooting tips.

7.3. Manual Calibration Checks

Informal calibration checks, which only evaluate but do not alter the analyzer’s response curve, are recommended as a regular maintenance item and in order to monitor the analyzer’s performance. To carry out a calibration check rather than a full calibration, follow these steps.

STEP ONE: Connect the sources of zero air and span gas as shown in Figures 7.1 or 7.2.

STEP TWO: Perform the zero/span calibration check procedure:

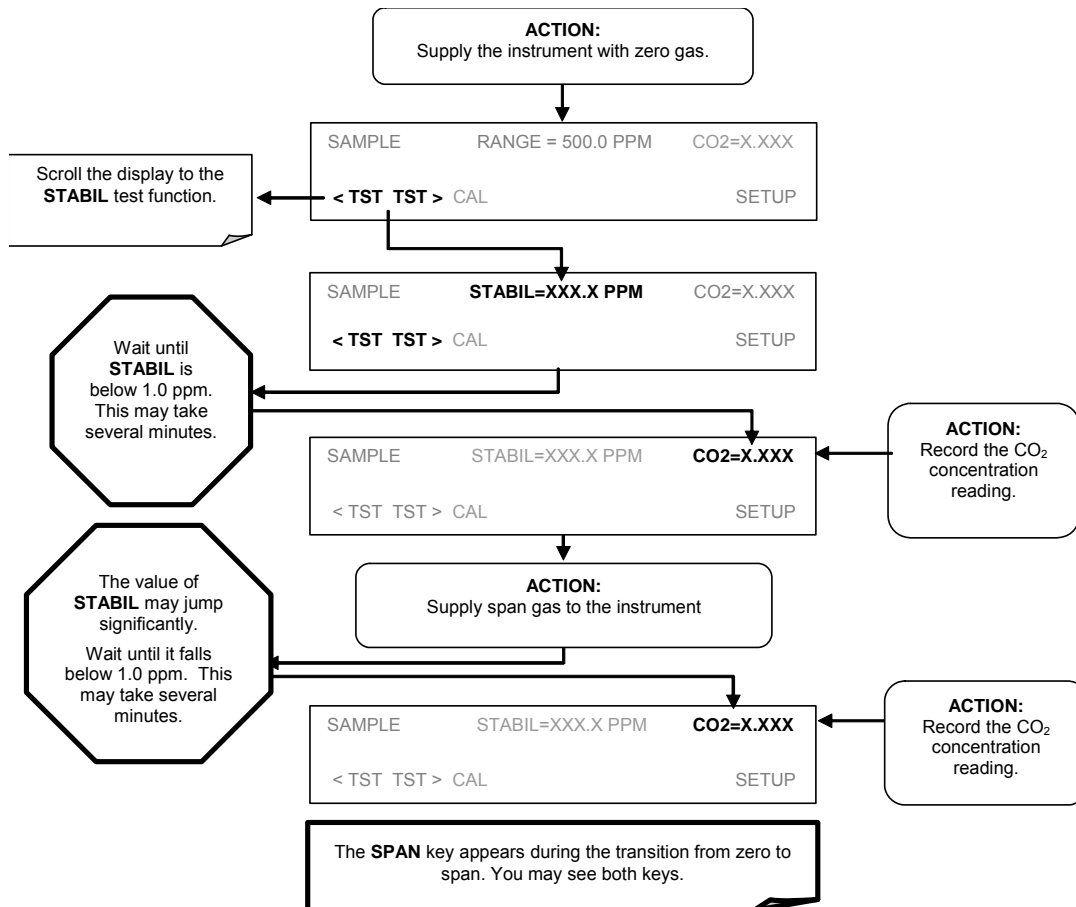

7.4. Manual Calibration with Zero/Span Valves

There are four different zero/span valve option configurations (See Section 5.4). They all operate identically, differing only in the method used to supply calibration gas to the Analyzer.

STEP ONE: Connect the sources of Zero Air and Span Gas as shown below.

Figures 7-3 through 7-6 show the proper pneumatic connections for M360E’s with various optional internal valve sets installed.

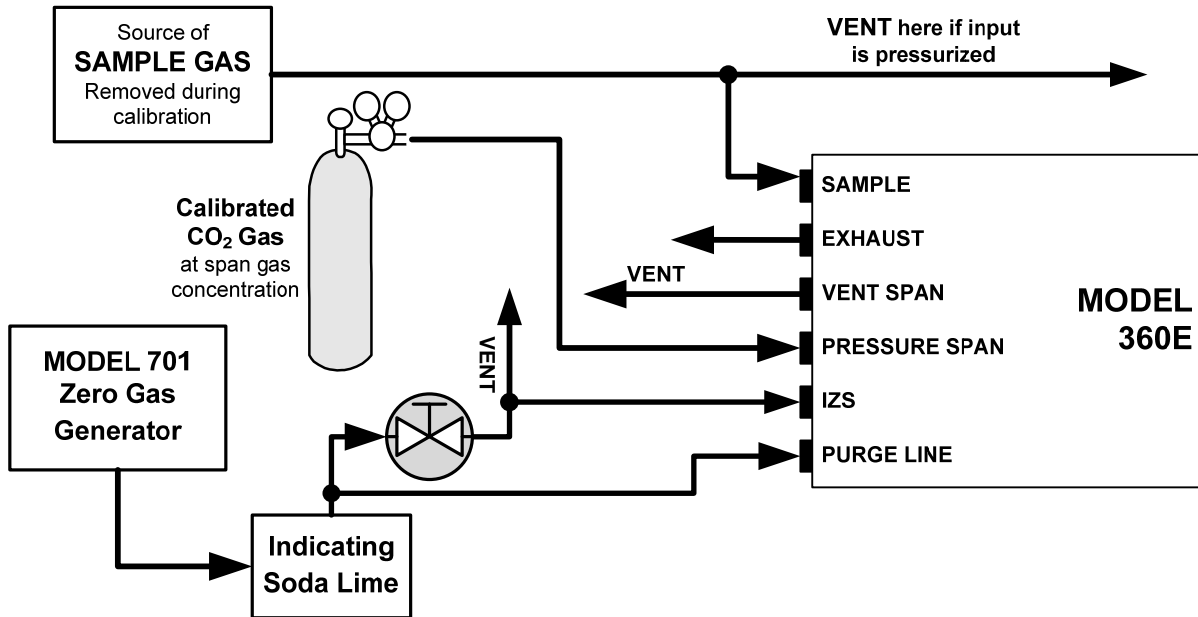

Figure 7-3: Pneumatic Connections—M360E with Zero/Span/Shutoff Valves (OPT 50)

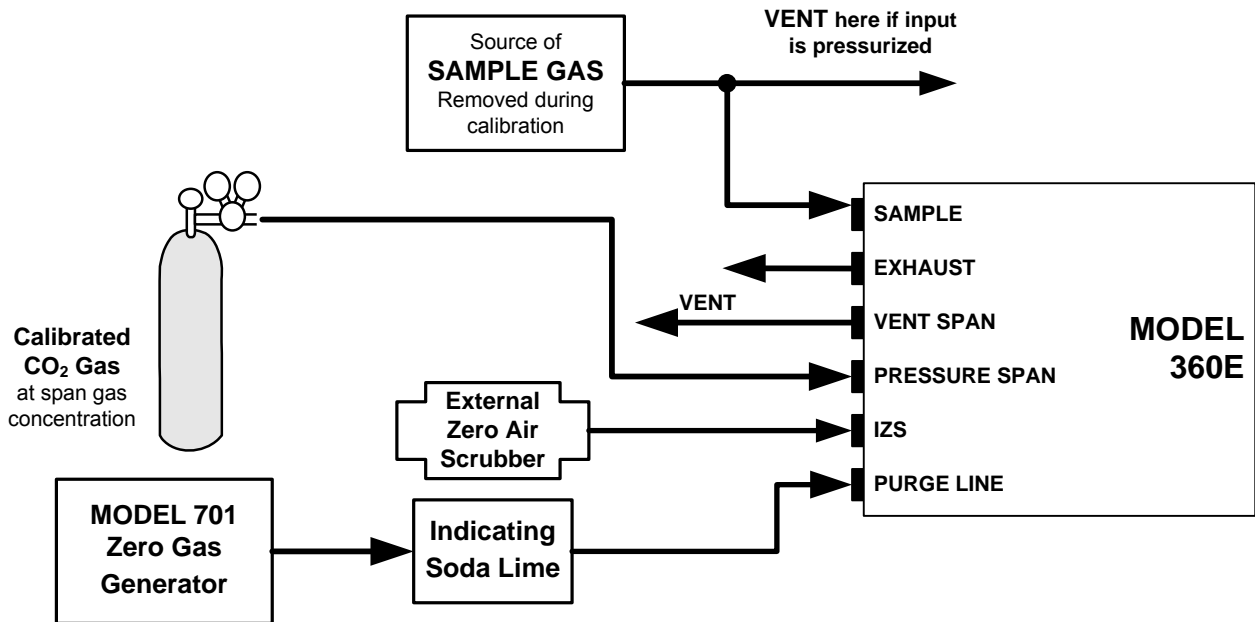

Figure 7-4 Pneumatic Connections—M360E with Zero/Span/Shutoff Valves and External Zero Air Scrubber (OPT 51)

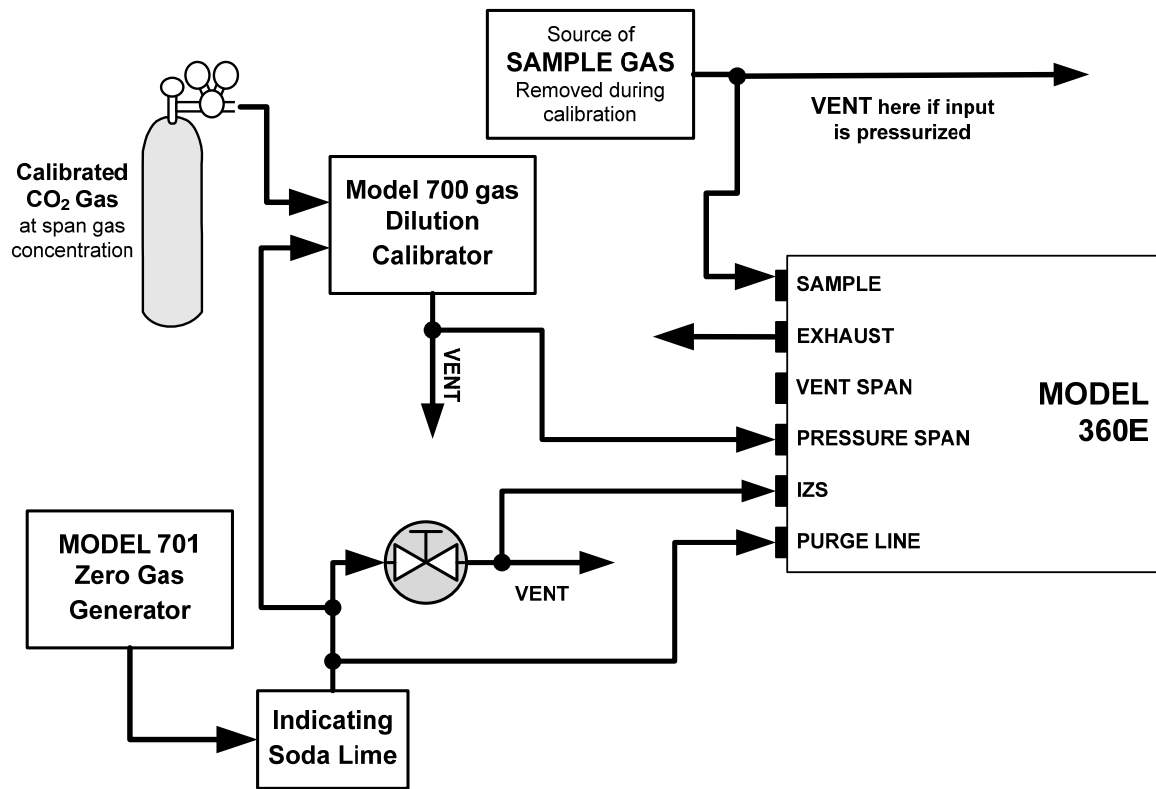

Figure 7-5: Pneumatic Connections—M360E with Zero/Span Valves (OPT 52)

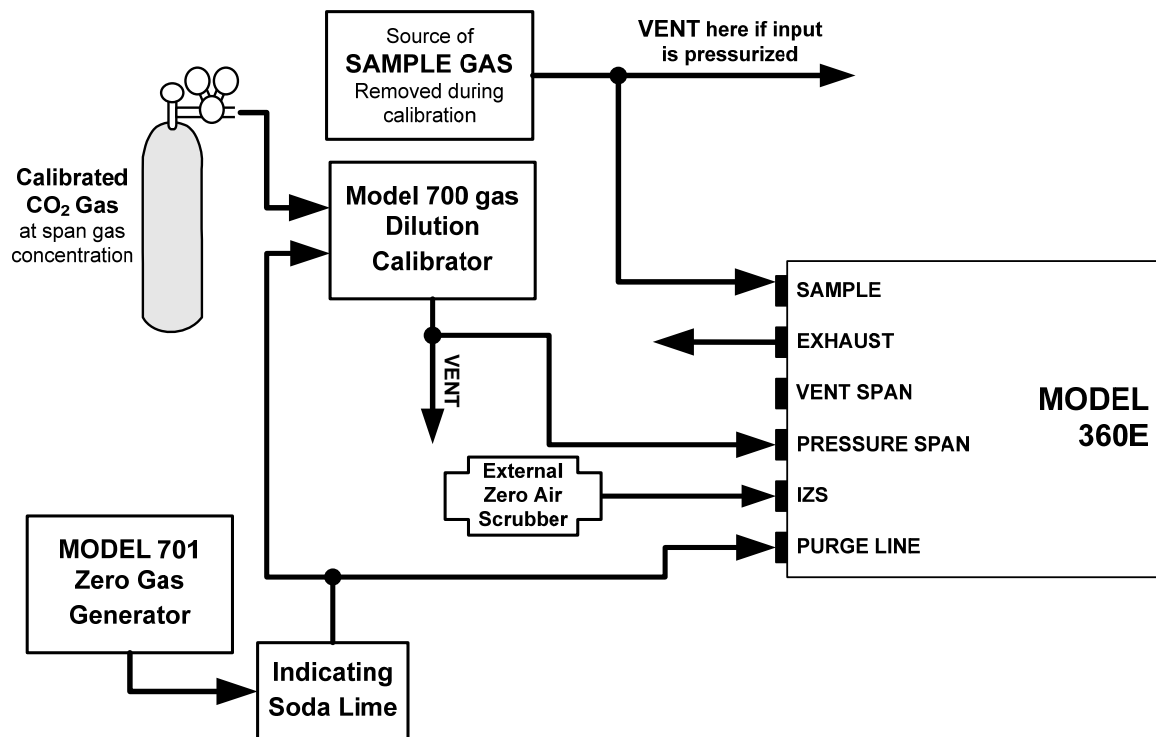
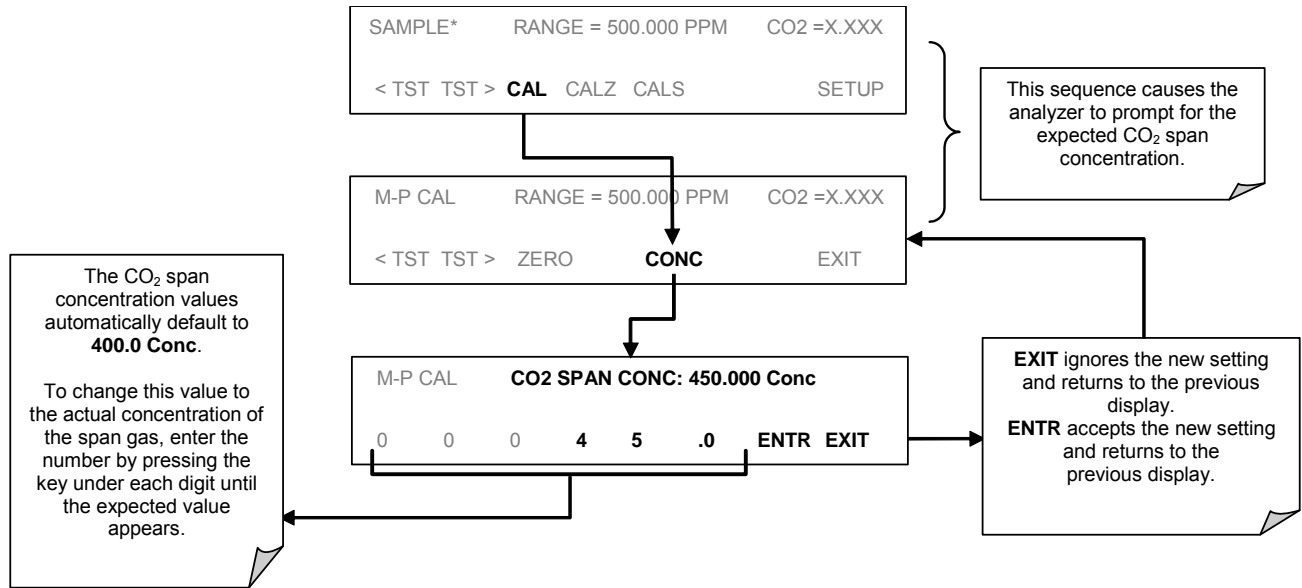

Figure 7-6: Pneumatic Connections—M360E with Zero/Span Valves with External Zero air Scrubber (OPT 53)

STEP TWO: Set the expected CO₂ Span Gas concentration:



NOTE

For this Initial Calibration it is important to independently verify the PRECISE CO₂ Concentration Value of the SPAN gas.

If the source of the Span Gas is from a Calibrated Bottle, use the exact concentration value printed on the bottle.

STEP THREE: Perform the zero/span calibration. Zero and span checks using the zero/span valve option are similar to that described in Section 7.2, except that zero air and span gas is supplied to the analyzer through the zero/span valves rather than through the sample inlet port.

The zero and cal operations are initiated directly and independently with dedicated keys (**CALZ & CALS**).

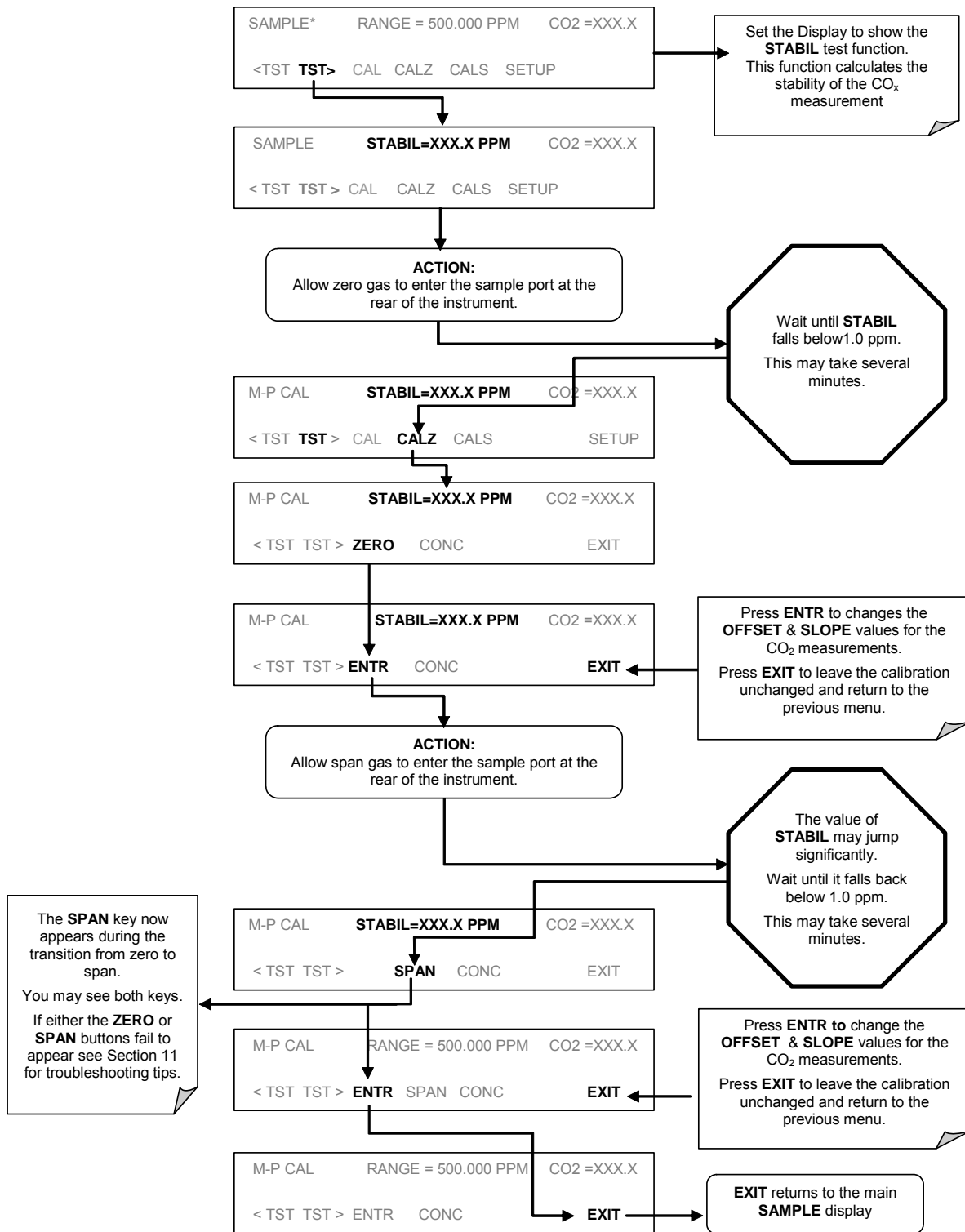

7.5. Manual Calibration Checks with Zero/Span Valves

Zero and span checks using the VARIOUS zero/span valve options available for the M360E are similar to that described in Section 7.3, except that the zero and calibration operations are initiated directly and independently with dedicated keys CALZ and CALS.

To perform a manual calibration check of an analyzer with a valve option installed, use the following method.

STEP ONE: Connect the sources of Zero Air and Span Gas as shown in Figures 7-3 through 7-6.

STEP TWO: Perform the zero/span check.

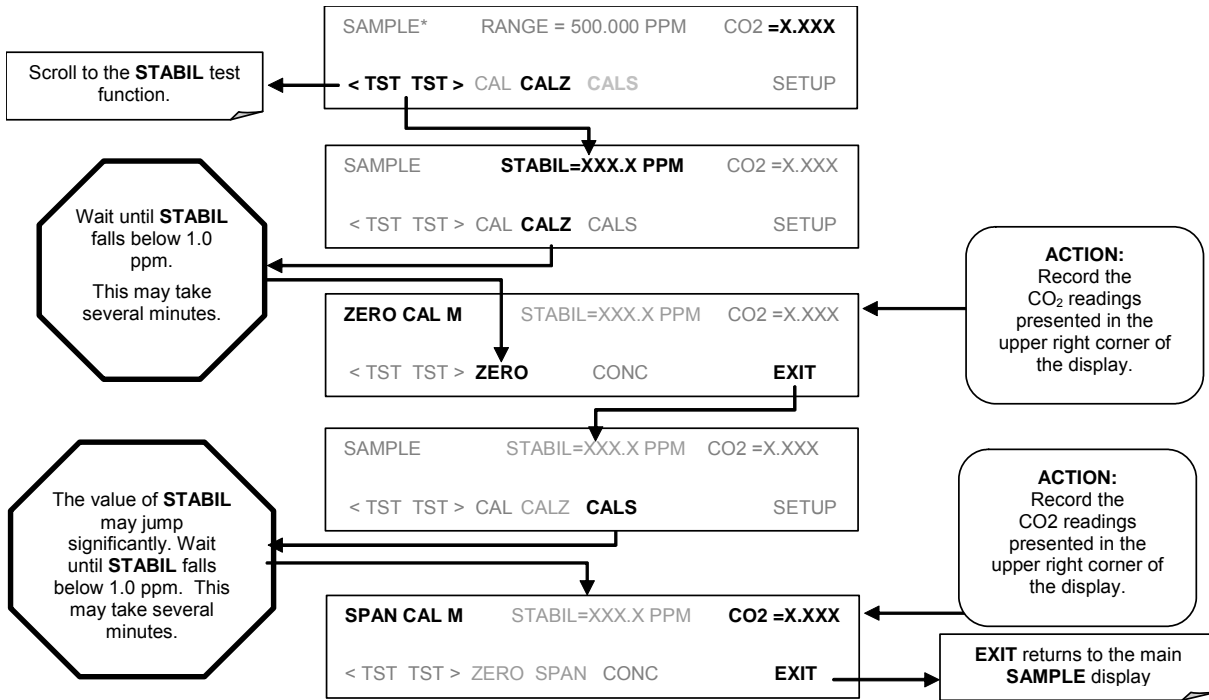

7.5.1. Zero/Span Calibration on Auto Range or Dual Ranges

If the analyzer is being operated in dual range mode or auto range mode, then the high and low ranges must be independently calibrated.

When the analyzer is in either dual or auto range modes the user must run a separate calibration procedure for each range. After pressing the **CAL**, **CALZ** or **CALS** keys the user is prompted for the range that is to be calibrated as seen in the **CALZ** example below:

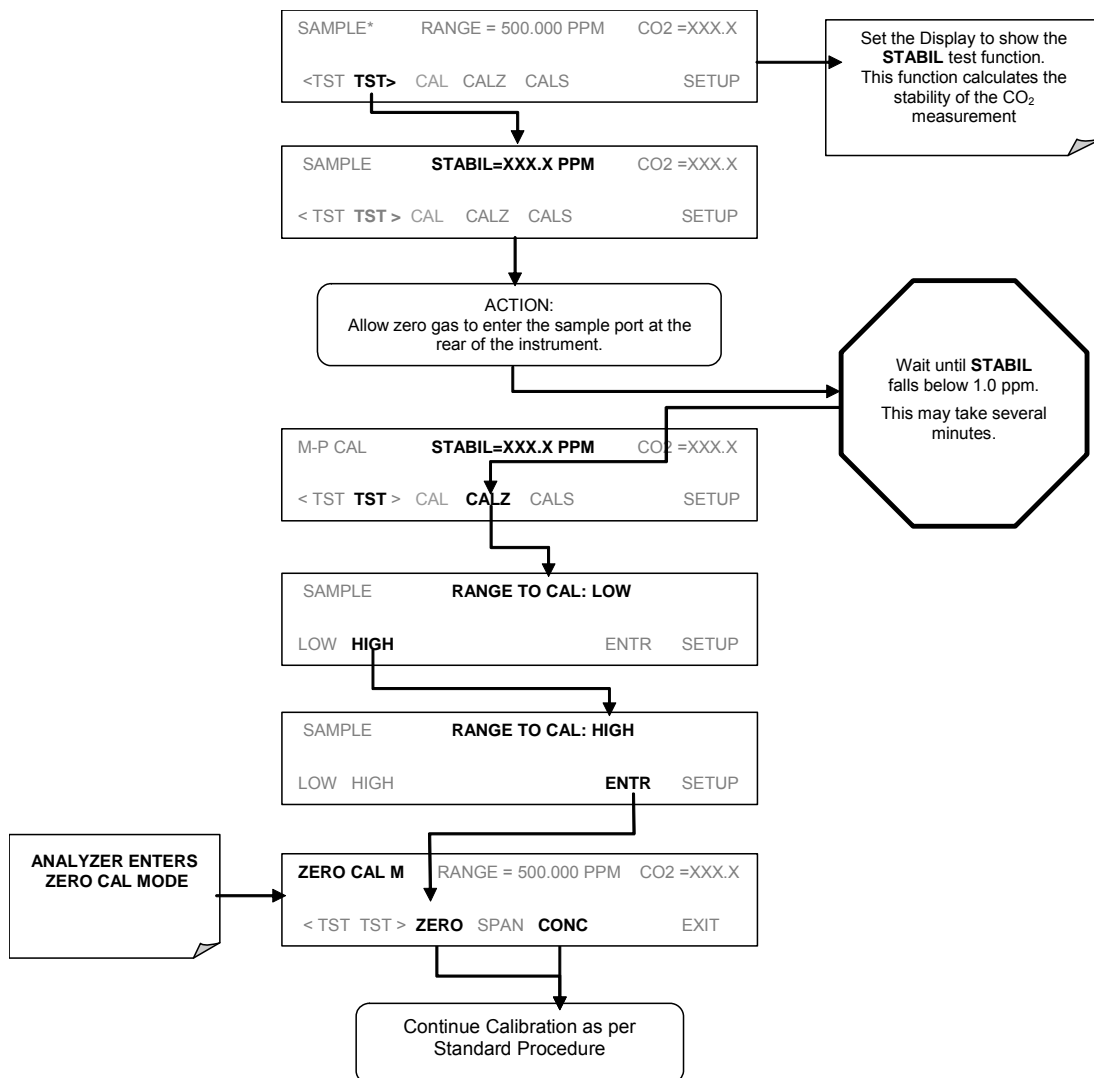

Once this selection is made, the calibration procedure continues as previously described in Section 7.2. The other range may be calibrated by starting over from the main **SAMPLE** display.

7.5.2. Use of Zero/Span Valves with Remote Contact Closure

Contact closures for controlling calibration are located on the rear panel CONTROL IN connector. Instructions for setup and use of these contacts are found in Section 6.15.1.2. When the contacts are closed for at least 5 seconds, the instrument switches into zero or span mode. The remote calibration contact closures may be activated in any order. It is recommended that contact closures remain closed for at least 10 minutes to establish a reliable reading.

The instrument will stay in the selected mode for as long as the contacts remain closed. If calibration is enabled, the M360E will re-calibrate when the contact is opened, then go into SAMPLE mode. If calibration is disabled, the instrument will return to SAMPLE mode, leaving the calibration unchanged.

7.6. Automatic Zero/Span Cal/Check (AutoCal)

The AutoCal system allows unattended periodic operation of the ZERO/SPAN valve options by using the M360E's internal time of day clock. AutoCal operates by executing SEQUENCES programmed by the user to initiate the various calibration modes of the analyzer and open and close valves appropriately. It is possible to program and run up to 3 separate sequences (**SEQ1**, **SEQ2** and **SEQ3**). Each sequence can operate in one of 3 Modes, or be disabled.

Table 7-1: AUTOCAL Modes

MODE NAME	ACTION
DISABLED	Disables the Sequence
ZERO	Causes the Sequence to perform a zero calibration/check
ZERO-SPAN	Causes the Sequence to perform a zero and span concentration calibration/check
SPAN	Causes the Sequence to perform a span concentration calibration/check

For each mode there are seven parameters that control operational details of the SEQUENCE. They are:

Table 7-2: AutoCal ATTRIBUTE Setup Parameters

ATTRIBUTE NAME	ACTION
TIMER ENABLED	Turns on the Sequence timer
STARTING DATE	Sequence will operate after Starting Date
STARTING TIME	Time of day sequence will run
DELTA DAYS	Number of days to skip between each Seq. execution
DELTA TIME	Number of hours later each "Delta Days" Seq is to be run
DURATION	Number of minutes the sequence operates
CALIBRATE	Enable to do a calibration – Disable to do a cal check only

The following example sets Sequence #2 to do a Zero-Span Calibration every other day starting at 1 am on September 4, 2001, lasting 15 minutes, without calibration. This will start ½ hour later each iteration.

MODE AND ATTRIBUTE	VALUE	COMMENT
Sequence	2	Define Sequence #2
Mode	ZERO-SPAN	Select Zero and Span Mode
Timer Enable	ON	Enable the timer
Starting Date	Sept. 4, 2001	Start after Sept 4, 2001
Starting Time	01:00	First Span starts at 1:00AM
Delta Days	2	Do Sequence #2 every other day
Delta Time	00:30	Do Sequence #2 ½ hr later each day
Duration	15.0	Operate Span valve for 15 min
Calibrate	NO	Do not calibrate at end of Sequence

NOTE

The programmed STARTING_TIME must be a minimum of 5 minutes later than the real time clock (See Section 6.10 for setting real time clock).

NOTE

Avoid setting two or more sequences at the same time of the day. Any new sequence which is initiated whether from a timer, the COM ports, or the contact closure inputs will override any sequence which is in progress.

NOTE

If at any time an illegal entry is selected (Example: Delta Days > 367) the ENTR key will disappear from the display.

To program the Sequence:

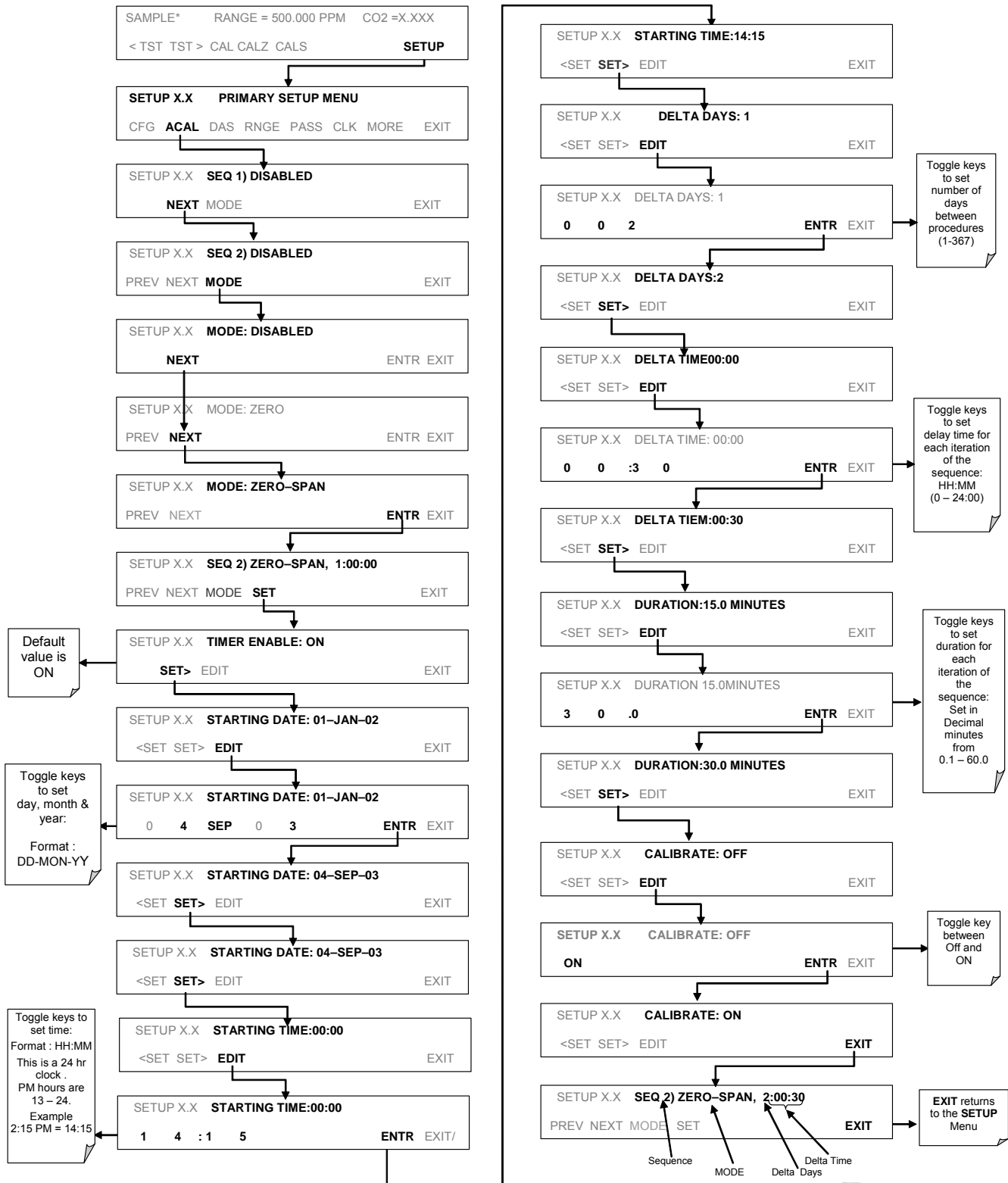

7.6.1. AutoCal with Auto or Dual Reporting Ranges Modes Selected

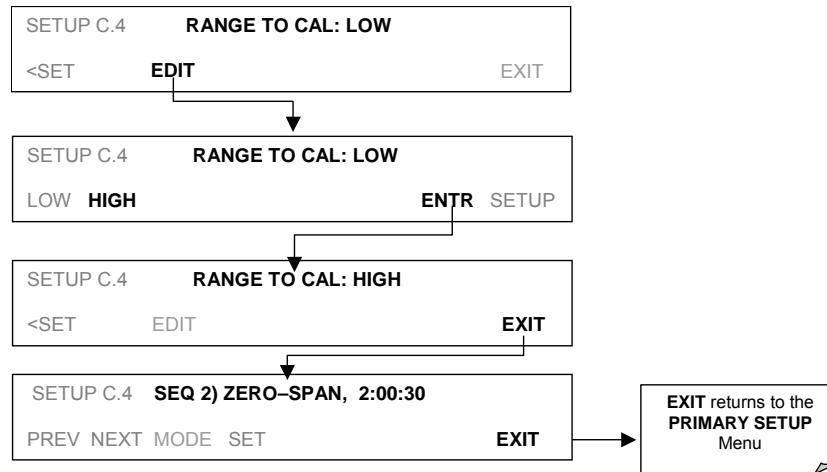

NOTE

In order to automatically calibrate both the HIGH and LOW ranges, you must set up a separate sequence for each.

7.7. Calibration Quality

After completing one of the calibration procedures described above, it is important to evaluate the analyzer's calibration SLOPE and OFFSET parameters. These values describe the linear response curve of the analyzer. The values for these terms, both individually and relative to each other, indicate the quality of the calibration. To perform this quality evaluation, you will need to record the values of both test functions (Section 6.2.1 or Appendix A-3), all of which are automatically stored in the iDAS channel CALDAT for data analysis, documentation and archival.

Make sure that these parameters are within the limits listed in Table 7-3 and frequently compare them to those values on the *Final Test and Checkout Sheet* that came attached to your manual, which should not be significantly different. If they are, refer to the troubleshooting Chapter 11.

Table 7-3: Calibration Data Quality Evaluation

FUNCTION	MINIMUM VALUE	OPTIMUM VALUE	MAXIMUM VALUE
SLOPE	0.700	1.000	1.300
OFFS	-0.500	0.000	0.500

These values should not be significantly different from the values recorded on the Teledyne Instruments *Final Test and Validation Data* sheet that was shipped with your instrument. If they are, refer to the troubleshooting Chapter 11.

The default iDAS configuration records all calibration values in channel **CALDAT** as well as all calibration check (zero and span) values in its internal memory. Up to 200 data points are stored for up 4 years of data (on weekly calibration checks) and a lifetime history of monthly calibrations. Review these data to see if the zero and span responses change over time. These channels also store the STABIL value (standard deviation of CO concentration) to evaluate if the analyzer response has properly leveled off during the calibration procedure. Finally, the CALDAT channel also stores the converter efficiency for review and documentation.

If your instrument has an O₂ sensor option installed that should be calibrated as well.

User Notes

8. EPA PROTOCOL CALIBRATION

At the writing of this manual there is no EPA requirements for the monitoring of CO₂ or published calibration protocols.

User Notes

9. MAINTENANCE SCHEDULE & PROCEDURES

Predictive diagnostic functions, including data acquisition records, failure warnings and test functions built into the analyzer, allow the user to determine when repairs are necessary without performing painstaking preventative maintenance procedures. There are, however, a minimal number of simple procedures that when performed regularly will ensure that the analyzer continues to operate accurately and reliably over its lifetime. Repairs and troubleshooting are covered in Chapter 11 of this manual.

9.1. Maintenance Schedule

Table 9-1 shows a typical maintenance schedule for the analyzer. Please note that in certain environments (i.e. dusty, very high ambient pollutant levels) some maintenance procedures may need to be performed more often than shown.

NOTE

A Span and Zero Calibration Check (see CAL CHECK REQ'D Column of Table 9-1) must be performed following certain of the maintenance procedure listed below.

See Sections 7.3, 7.5 and 7.6 for instructions on performing checks.



CAUTION

Risk of electrical shock. Disconnect power before performing any of the following operations that require entry into the interior of the analyzer.



NOTE

The operations outlined in this chapter are to be performed by qualified maintenance personnel only.

Table 9-1: M360E Maintenance Schedule

ITEM	ACTION	FREQ	CAL CHECK REQ'D.	MANUAL	DATE PERFORMED																	
Particulate Filter	Replace	Weekly or as needed	Yes																			
Verify Test Functions	Record and analyze	Weekly or after any Maintenance or Repair	No																			
Pump Diaphragm	Replace	Annually	Yes																			
Perform Flow Check	Check Flow	Annually	No																			
Perform Leak Check	Verify Leak Tight	Annually or after any Maintenance or Repair	No																			
Pneumatic lines	Examine and clean	As needed	Yes if cleaned																			
Cleaning	Clean	As needed	Only if cover remv'd																			

Table 9-2: M360E Test Function Record

FUNCTION	OPERATING MODE*	DATE RECORDED													
STABILITY	ZERO CAL														
CO2 MEAS	ZERO CAL														
MR RATIO	Zero CAL														
	SPAN CAL														
PRES	SAMPLE														
PHT DRIVE	SAMPLE After Warm-up														
SLOPE	SPAN CAL														
OFFSET	ZERO CAL														

9.2. Predicting Failures Using the Test Functions

The Test Functions can be used to predict failures by looking at how their values change over time. Initially it may be useful to compare the state of these Test Functions to the values recorded on the printed record of the final calibration performed on your instrument at the factory, p/n 04307. Table 9-3 can be used as a basis for taking action as these values change with time. The internal data acquisition system (iDAS) is a convenient way to record and track these changes. Use APICOM to download and review this data from a remote location.

Table 9-3: Predictive uses for Test Functions

FUNCTION	CONDITION	BEHAVIOR	INTERPRETATION
STABILITY	Zero Cal	Increasing	Pneumatic Leaks – instrument & sample system Detector deteriorating
CO2 MEAS	Zero Cal	Decreasing	Source Aging Detector deteriorating Optics getting dirty or contaminated
MR RATIO	Zero Cal	Increasing	Source Aging Detector deteriorating Contaminated zero gas (H2O)
		Decreasing	Source Aging Detector deteriorating GFC Wheel Leaking Pneumatic Leaks Contaminated zero gas (CO ₂)
	Span Cal	Increasing	Source Aging Pneumatic Leaks – instrument & sample system Calibration system deteriorating
		Decreasing	Source Aging GFC Wheel Leaking Calibration system deteriorating
PRES	Sample	Increasing > 1"	Pneumatic Leak between sample inlet and Sample Cell Change in sampling manifold
		Decreasing > 1"	Dirty particulate filter Pneumatic obstruction between sample inlet and Sample Cell Obstruction in sampling manifold
PHT DRIVE	Any, but with Bench Temp at 48°C	Increasing	Mechanical Connection between IR-Detector and Sample Cell deteriorating IR-Photodetector deteriorating
OFFSET	Zero Cal	Increasing	See MR Ratio - Zero Cal Decreasing above
		Decreasing	See MR Ratio - Zero Cal Increasing above
SLOPE	Span Cal	Increasing	See MR Ratio - Span Cal Decreasing above
		Decreasing	See MR Ratio – Span Cal Increasing above

9.3. Maintenance Procedures

The following procedures are to be performed periodically as part of the standard maintenance of the Model 360E.

9.3.1. Replacing the Sample Particulate Filter

The particulate filter should be inspected often for signs of plugging or contamination. We recommend that when you change the filter, handle it and the wetted surfaces of the filter housing as little as possible. Do not touch any part of the housing, filter element, PTFE retaining ring, glass cover and the o-ring.

To change the filter:

1. Turn OFF the analyzer to prevent drawing debris into the instrument.
2. Open the M360E's hinged front panel and unscrew the knurled retaining ring on the filter assembly.

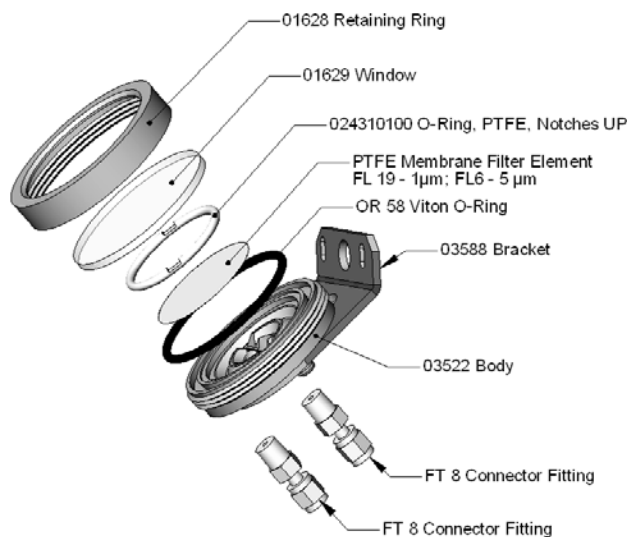

Figure 9-1: Sample Particulate Filter Assembly

3. Carefully remove the retaining ring, PTFE o-ring, glass filter cover and filter element.
4. Replace the filter, being careful that the element is fully seated and centered in the bottom of the holder.
5. Re-install the PTFE o-ring with the notches up, install the glass cover, then screw on the retaining ring and hand tighten. Inspect the seal between the edge of filter and the o-ring to assure a proper seal.
6. Re-start the Analyzer.

9.3.2. Rebuilding the Sample Pump

The diaphragm in the sample pump periodically wears out and must be replaced. A sample rebuild kit is available – see Appendix B of this manual for the part number of the pump rebuild kit. Instructions and diagrams are included with the kit.

Always perform a Flow and Leak Check after rebuilding the Sample Pump.

9.3.3. Performing Leak Checks

Leaks are the most common cause of analyzer malfunction; Section 9.3.3.1 presents a simple leak check procedure. Section 9.3.3.2 details a more thorough procedure.

9.3.3.1. Vacuum Leak Check and Pump Check

This method is easy and fast. It detects, but does not locate most leaks; it also verifies that the sample pump is in good condition.

1. Turn the analyzer ON, and allow enough time for flows to stabilize.
2. Cap the sample inlet port.
3. After several minutes, when the pressures have stabilized, note the following. In the **TEST** menu, note the **SAMPLE PRESSURE** reading.
4. If the reading is < 10 in-Hg, the pump is in good condition and there are no large leaks.
5. Check the sample gas flow. If the flow is <10 cm³/min and stable, there are no large leaks in the instrument's pneumatics.

9.3.3.2. Pressure Leak Check

If you can't locate the leak by the above procedure, use the following procedure. Obtain a leak checker similar to the Teledyne Instruments part number 01960, which contains a small pump, shut-off valve, and pressure gauge. Alternatively, a convenient source of low-pressure gas is a tank of span gas, with the two-stage regulator adjusted to less than 15 psi with a shutoff valve and pressure gauge.



CAUTION

Do not use bubble solution with vacuum applied to the analyzer. The solution may contaminate the instrument. Do not exceed 15 PSIG pressure.

1. Turn OFF power to the instrument.
2. Install a leak checker or tank of gas as described above on the sample inlet at the rear panel.
3. Remove the instrument cover and locate the inlet side of the sample pump. Remove the flow assembly from the pump and plug it with the appropriate gas-tight fitting.
4. Pressurize the instrument with the leak checker, allowing enough time to fully pressurize the instrument through the critical flow orifice. Check each fitting with soap bubble solution, looking for bubbles. Once the fittings have been wetted with soap solution, do not re-apply vacuum, as it will suck soap solution into the instrument and contaminate it. Do not exceed 15 psi pressure.
5. If the instrument has one of the zero and span valve options, the normally closed ports on each valve should also be separately checked. Connect the leak checker to the normally closed ports and check with soap bubble solution.
6. Once the leak has been located and repaired, the leak-down rate should be < 1 in-Hg (0.4 psi) in 5 minutes after the pressure is shut off.

9.3.4. Performing a Sample Flow Check

**CAUTION**

Always use a separate calibrated flow meter capable of measuring flows in the 0 – 1000 cc/min range to measure the gas flow rate through the analyzer.

DO NOT use the built in flow measurement viewable from the Front Panel of the instrument. This measurement is only for detecting major flow interruptions such as clogged or plugged gas lines.

See Figure 3-2 for sample port location.

1. Attach the Flow Meter to the sample inlet port on the rear panel. Ensure that the inlet to the Flow Meter is at atmospheric f.
2. Sample flow should be 800 cc/min \pm 10%.
3. Once an accurate measurement has been recorded by the method described above, adjust the analyzer's internal flow sensors (See Section 6.13.8)

Low flows indicate blockage somewhere in the pneumatic pathway, typically a plugged sintered filter or critical flow orifice in one of the analyzer's flow control assemblies. High flows indicate leaks downstream of the Flow Control Assembly.

9.3.5. Cleaning the Optical Bench

The M360E sensor assembly and optical bench is complex and delicate. Disassembly and cleaning is not recommended. Please check with the factory before disassembling the optical bench.

9.3.6. Cleaning Exterior Surfaces of the M360E

If necessary, the exterior surfaces of the M360E can be cleaned with a clean damp cloth. Do not submerge any part of the instrument in water or cleaning solution.

User Notes

10. THEORY OF OPERATION

The Model 360E Gas Filter Correlation Carbon Dioxide Analyzer is a microprocessor-controlled analyzer that determines the concentration of carbon dioxide (CO₂) in a sample gas drawn through the instrument. It requires that sample and calibration gasses be supplied at ambient atmospheric pressure in order to establish a stable gas flow through the sample chamber where the gases ability to absorb infrared radiation is measured.

Calibration of the instrument is performed in software and does not require physical adjustments to the instrument. During calibration the microprocessor measures the current state of the IR Sensor output and various other physical parameters of the instrument and stores them in memory.

The microprocessor uses these calibration values, the IR absorption measurements made on the sample gas along with data regarding the current temperature and pressure of the gas to calculate a final CO₂ concentration.

This concentration value and the original information from which it was calculated are stored in one of the unit's internal data acquisition system (iDAS - See Sections 6.7) as well as reported to the user via a vacuum florescent display or a variety of digital and analog signal outputs.

10.1. Measurement Method

10.1.1. Beer's Law

The basic principle by which the analyzer works is called Beer's Law. It defines the how light of a specific wavelength is absorbed by a particular gas molecule over a certain distance. The mathematical relationship between these three parameters is:

$$I = I_0 e^{-\alpha Lc}$$

Where:

I₀ is the intensity of the light if there was no absorption.

I is the intensity with absorption.

L is the absorption path, or the distance the light travels as it is being absorbed.

C is the concentration of the absorbing gas. In the case of the Model 360E, carbon dioxide (CO₂).

α is the absorption coefficient that tells how well CO₂ absorbs light at the specific wavelength of interest.

10.1.2. Measurement Fundamentals

In the most basic terms, the Model 360E uses a high energy heated element to generate a beam of broad-band IR light with a known intensity (measured during Instrument calibration. This beam is directed through multi-pass cell filled with sample gas. The sample cell uses mirrors at each end to reflect the IR beam back and forth through the sample gas to generate a 2.5 meter absorption path (see Figure 10-1). This length was chosen to give the analyzer maximum sensitivity to fluctuations in CO₂ density.

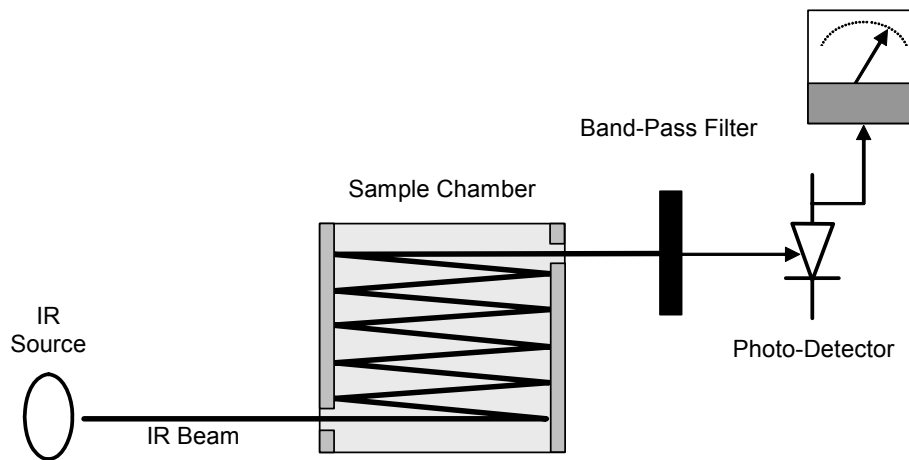

Figure 10-1: Measurement Fundamentals

Upon exiting the sample cell, the beam shines through a band-pass filter that allows only light at a wavelength of $4.3\ \mu\text{m}$ to pass. Finally, the beam strikes a solid-state photo-detector that converts the light signal into a modulated voltage signal representing the attenuated intensity of the beam.

10.1.3. Gas Filter Correlation

Unfortunately, water vapor absorbs light at $4.3\ \mu\text{m}$ too. To overcome the interfering effects of water vapor the Model 360E adds another component to the IR light path called a gas filter correlation (GFC) wheel (see Figure 10-2).

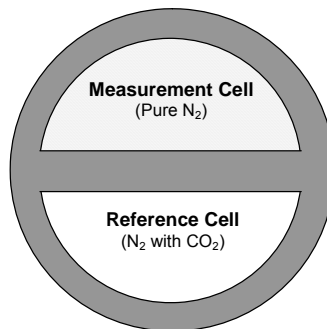

Figure 10-2: GFC Wheel

10.1.3.1. The GFC Wheel

A GFC wheel is a metallic wheel into which two chambers are carved. The chambers are sealed on both sides with material transparent to $4.3\ \mu\text{m}$ IR radiation creating two airtight cavities. Each cavity is filled with specially composed gases. One cell is filled with pure N_2 (the measure cell). The other is filled with a combination of N_2 and a high concentration of CO_2 (the reference cell).

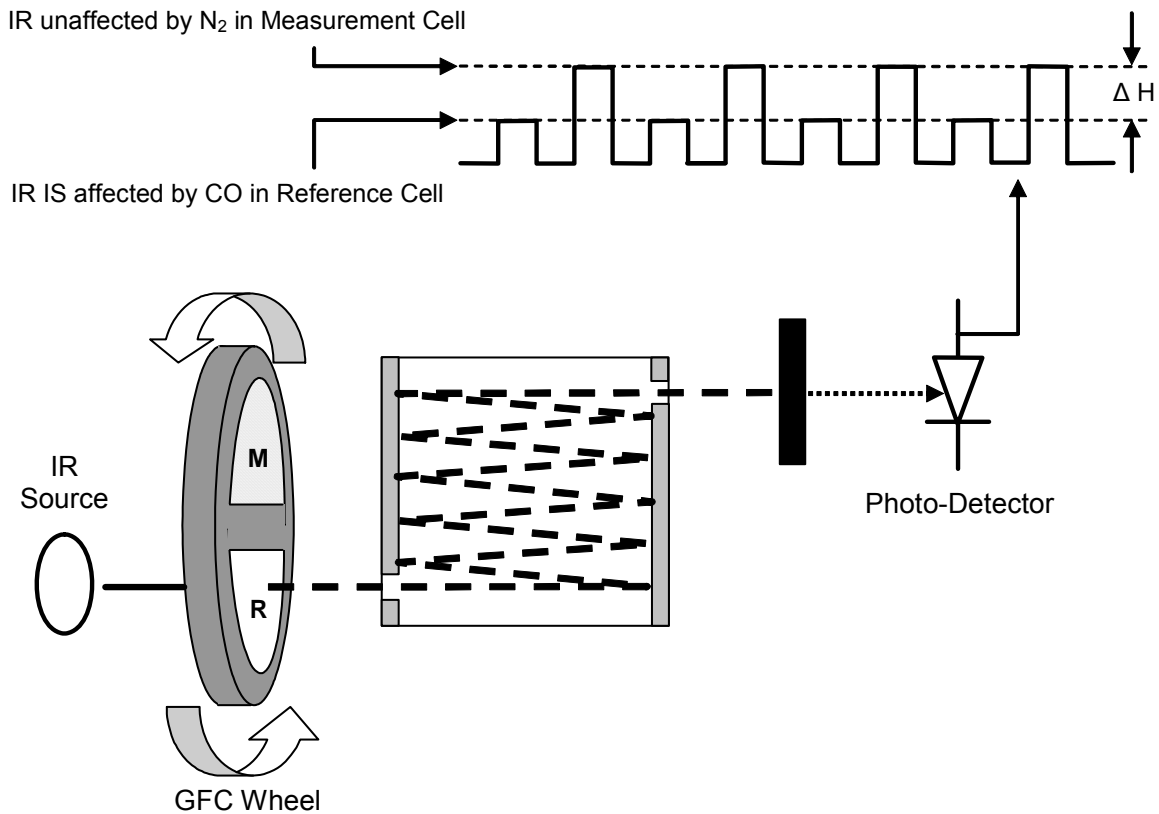

Figure 10-3: Measurement Fundamentals with GFC Wheel

As the GFC wheel spins, the IR light alternately passes through the two cavities. When the beam is exposed to the reference cell, the CO_2 in the gas filter wheel strips the beam of most of the IR at $4.3\mu m$. When the light beam is exposed to the measurement cell, the N_2 in the filter wheel does not absorb IR light. This results in a fluctuation in the intensity of the IR light striking the photo-detector (See Figure 10-3) that results in the output of the detector resembling a square wave.

10.1.3.2. The Measure Reference Ratio

The Model 360E determines the amount of CO_2 in the sample chamber by computing the ratio between the peak of the measurement pulse (**CO2 MEAS**) and the peak of the reference pulse (**CO2 REF**).

If no gases exist in the sample chamber that absorb light at $4.3\mu m$, the high concentration of CO_2 in the gas mixture of the reference cell will attenuate the intensity of the IR beam by 60% giving a M/R ratio of approximately 2.4:1.

Adding CO_2 to the sample chamber causes the peaks corresponding to both cells to be attenuated by a further percentage. Since the intensity of the light passing through the measurement cell is greater, the effect of this additional attenuation is greater. This causes **CO2 MEAS** to be more sensitive to the presence of CO_2 in the sample chamber than **CO2 REF** and the ratio between them (M/R) to move closer to 1:1 as the concentration of CO_2 in the sample chamber increases.

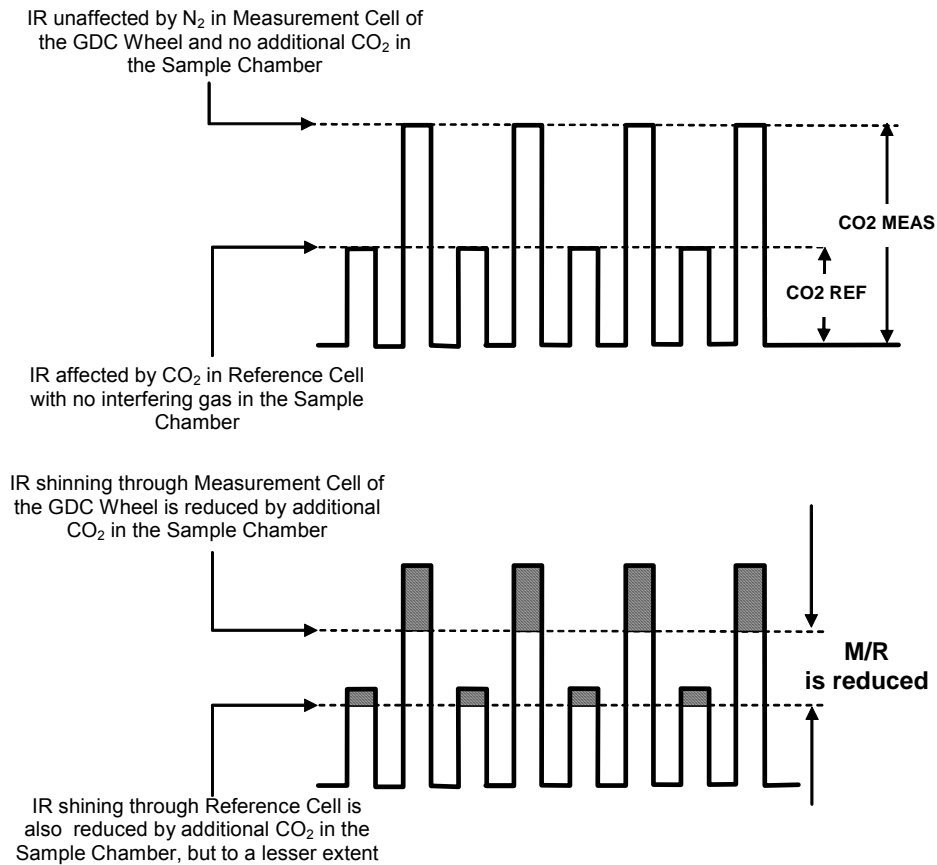

Figure 10-4: Affect of CO₂ in the Sample on CO₂ MEAS & CO₂ REF

Once the Model 360E has computed this ratio, a look-up table is used, with interpolation, to linearize the response of the instrument. This linearized concentration value is combined with calibration **SLOPE** and **OFFSET** values to produce the CO₂ concentration which is then normalized for changes in sample pressure.

10.1.4. Interference and Signal to Noise Rejection

If an interfering gas, such as H₂O vapor is introduced into the sample chamber, the spectrum of the IR beam is changed in a way that is identical for both the reference and the measurement cells, but without changing the ratio between the peak heights of **CO₂ MEAS** and **CO₂ REF**. In effect, the difference between the peak heights remains the same.

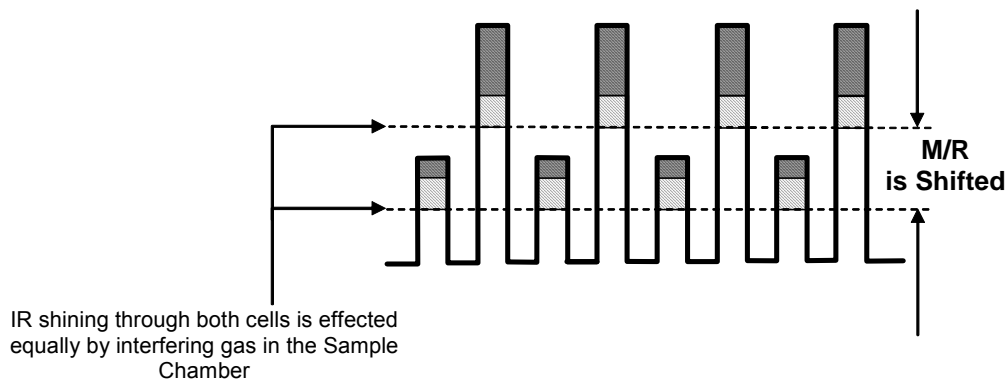

Figure 10-5: Effects of Interfering Gas on CO₂ MEAS & CO₂ REF

Thus, the difference in the peak heights and the resulting M/R ratio is only due to CO₂ and not to interfering gases. In this way, Gas filter correlation rejects the effects of interfering gases and so that the analyzer responds only to the presence of CO₂.

To improve the signal-to-noise performance of the IR photo-detector, the GFC wheel also incorporates an optical mask that chops the IR beam into alternating pulses of light and dark at six times the frequency of the measure/reference signal. This limits the detection bandwidth helping to reject interfering signals from outside this bandwidth improving the signal to noise ratio.

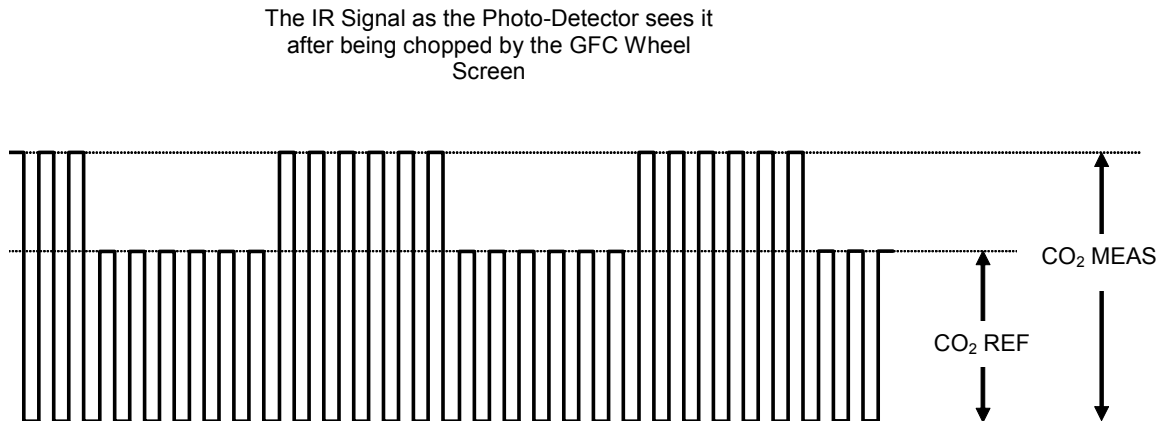

Figure 10-6: Chopped IR Signal

10.1.4.1. Ambient CO₂ Interference Rejection

CO₂ absorbs IR light very well. So well that even the narrow volume of ambient air between the IR source and the sample chamber is enough to alter the analyzer's measured concentration of CO₂. Also, ambient air, which averages around 350 ppm to 400 ppm, will vary significantly over the course of the day. The ambient CO₂ concentration can rise as high as 1 000 ppm during the time of the day when people are present. It can fluctuate ± 300 ppm as the photosynthesis of plant life in the nearby area increases during the day and decreases at night.

The basic design of the M360E rejects most of this interference at a 100:1 ratio; however this still can allow small fluctuations in CO₂ concentration during the course of the day. To completely remove all effects of ambient CO₂ from the analyzer's measurement of CO₂, dried air, scrubbed of all CO₂ is pumped into the GFC wheel housing to purge all ambient CO₂ (see Figure 10-7)

10.2. Pneumatic Operation



CAUTION

It is important that the sample airflow system is both leak tight and not pressurized over ambient pressure.

Regular leak checks should be performed on the analyzer as described in the maintenance schedule, Table 9-1.

Procedures for correctly performing leak checks can be found in Section 9.3.3.

An internal pump evacuates the sample chamber creating a small vacuum that draws sample gas into the analyzer. Normally the analyzer is operated with its inlet near ambient pressure either because the sample is directly drawn at the inlet or a small vent is installed at the inlet. There are several advantages to this “pull through” configuration.

- By placing the pump down stream from the sample chamber several problems are avoided.
- First the pumping process heats and compresses the sample air complicating the measurement process.
- Additionally, certain physical parts of the pump itself are made of materials that might chemically react with the sample gas.
- Finally, in certain applications where the concentration of the target gas might be high enough to be hazardous, maintaining a negative gas pressure relative to ambient means that should a minor leak occur, no sample gas will be pumped into the atmosphere surrounding analyzer.

10.2.1. Sample Gas Flow

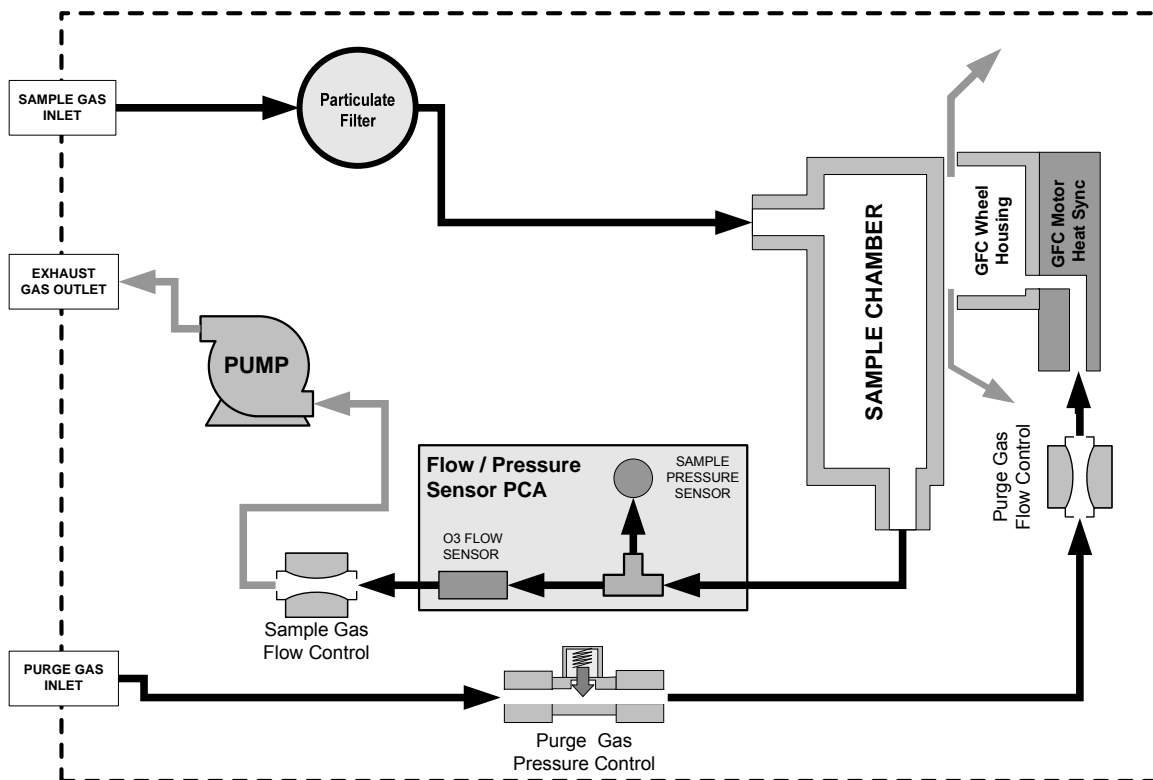

Figure 10-7: Internal Pneumatic Flow – Basic Configuration

10.2.2. Flow Rate Control

To maintain a constant flow rate of the sample gas through the instrument, the Model 360E uses special flow control assemblies located in the purge gas line at the entrance to the GFC wheel housing and in the exhaust gas line just before the pump (see Figure 10-7). These assemblies consists of:

- A critical flow orifice.
- Two o-rings: Located just before and after the critical flow orifice, the o-rings seal the gap between the walls of assembly housing and the critical flow orifice.
- A spring: Applies mechanical force needed to form the seal between the o-rings, the critical flow orifice and the assembly housing.

10.2.2.1. Critical Flow Orifice

The most important component of this flow control assembly is the critical flow orifice.

Critical flow orifices are a remarkably simple way to regulate stable gas flow rates. They operate without moving parts by taking advantage of the laws of fluid dynamics. By restricting the flow of gas through the orifice, a pressure differential is created. This pressure differential combined with the action of the analyzer's pump draws the gas through the orifice.

As the pressure on the downstream side of the orifice (the pump side) continues to drop, the speed that the gas flows through the orifice continues to rise. Once the ratio of upstream pressure to downstream pressure is greater than 2:1, the velocity of the gas through the orifice reaches the speed of sound. As long as that ratio stays at least 2:1 the gas flow rate is unaffected by any fluctuations, surges, or changes in downstream pressure because such variations only travel at the speed of sound themselves and are therefore cancelled out by the sonic shockwave at the downstream exit of the critical flow orifice.

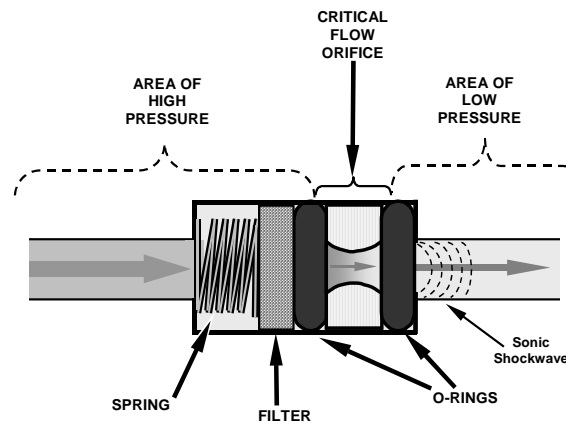

Figure 10-8: Flow Control Assembly & Critical Flow Orifice

The actual flow rate of gas through the orifice (volume of gas per unit of time), depends on the size and shape of the aperture in the orifice. The larger the hole, the more gas molecules, moving at the speed of sound, pass through the orifice. Because the flow rate of gas through the orifice is only related to the minimum 2:1 pressure differential and not absolute pressure the flow rate of the gas is also unaffected by degradations in pump efficiency due to age.

The critical flow orifice used in the Model 360E is designed to provide a flow rate of 800 cm³/min.

10.2.3. Purge Gas Pressure Control

In order to ensure that all of the ambient CO₂ is purged from the GFC Wheel housing an adequate supply of dried air, scrubbed of CO₂ must be supplied to the **PURGE AIR** inlet at the back of the instrument.

- The minimum gas pressure of the source of purge air should be 7.5 psig.
- If the source of the purge air is shared by a Teledyne Instruments M700 (as shown in figure 3-7) the minimum gas pressure should be 25 psig and should not exceed 35 psig.

In order to maintain the proper pressure differential between the inside of the GFC wheel housing and ambient air, the M360 design includes a manually settable pressure regulator that maintains the pressure of the purge air feed at 7.5 psig.

10.2.4. Particulate Filter

The Model 360E Analyzer comes equipped with a 47 mm diameter, Teflon, particulate filter with a 5 micron pore size. The filter is accessible through the front panel, which folds down to allow access, and should be changed according to the suggested maintenance schedule described in Table 9-1.

10.2.5. Pneumatic Sensors

10.2.5.1. Sample Pressure Sensor

An absolute value pressure transducer plumbed to the outlet of the sample chamber is used to measure sample pressure. The output of the sensor is used to compensate the concentration measurement for changes in air pressure. This sensor is mounted to a printed circuit board with the sample flow sensor on the sample chamber; see the following section and Figure 3-3.

10.2.5.2. Sample Flow Sensor

A thermal-mass flow sensor is used to measure the sample flow through the analyzer. The sensor is calibrated at the factory with ambient air or N₂, but can be calibrated to operate with samples consisting of other gases such as CO₂. See Section 9.3.4. This sensor is mounted to a printed circuit board with the Sample Pressure sensor on the sample chamber; see the previous section and Figure 3-3.

10.3. Electronic Operation

10.3.1. Overview

Figure 10-9 shows a block diagram of the major electronic components of the Model 360E.

At its heart the analyzer is a microcomputer (CPU) that controls various internal processes, interprets data, makes calculations, and reports results using specialized firmware developed by Teledyne Instruments. It communicates with the user as well as receives data from and issues commands to a variety of peripheral devices via a separate printed circuit assembly called the Mother Board.

The mother board collects data, performs signal conditioning duties and routs incoming and outgoing signals between the CPU and the analyzer's other major components.

Data is generated by a gas-filter-correlation optical bench which outputs an analog signal corresponding to the concentration of CO₂ in the sample gas. This analog signal is transformed into two, pre-amplified, DC voltages (**CO2 MEAS** and **CO2 REF**) by a synchronous demodulator printed circuit assembly. **CO2 MEAS** and **CO2 REF** are converted into digital data by a unipolar, analog-to-digital converter, located on the mother board.

A variety of sensors report the physical and operational status of the analyzer's major components, again through the signal processing capabilities of the mother board. These status reports are used as data for the CO₂ concentration calculation and as trigger events for certain control commands issued by the CPU. They are stored in memory by the CPU and in most cases can be viewed but the user via the front panel display.

The CPU communicates with the user and the outside world in a variety of manners:

- Through the analyzer's keyboard and vacuum florescent display over a clocked, digital, serial I/O bus (using a protocol called I²C);
- RS 232 & RS485 Serial I/O channels;
- Via an optional Ethernet communications card;
- Various DCV and DCA analog outputs, and
- Several sets of Digital I/O channels.

Finally, the CPU issues commands via a series of relays and switches (also over the I²C bus) located on a separate printed circuit assembly to control the function of key electromechanical devices such as heaters, motors and valves.

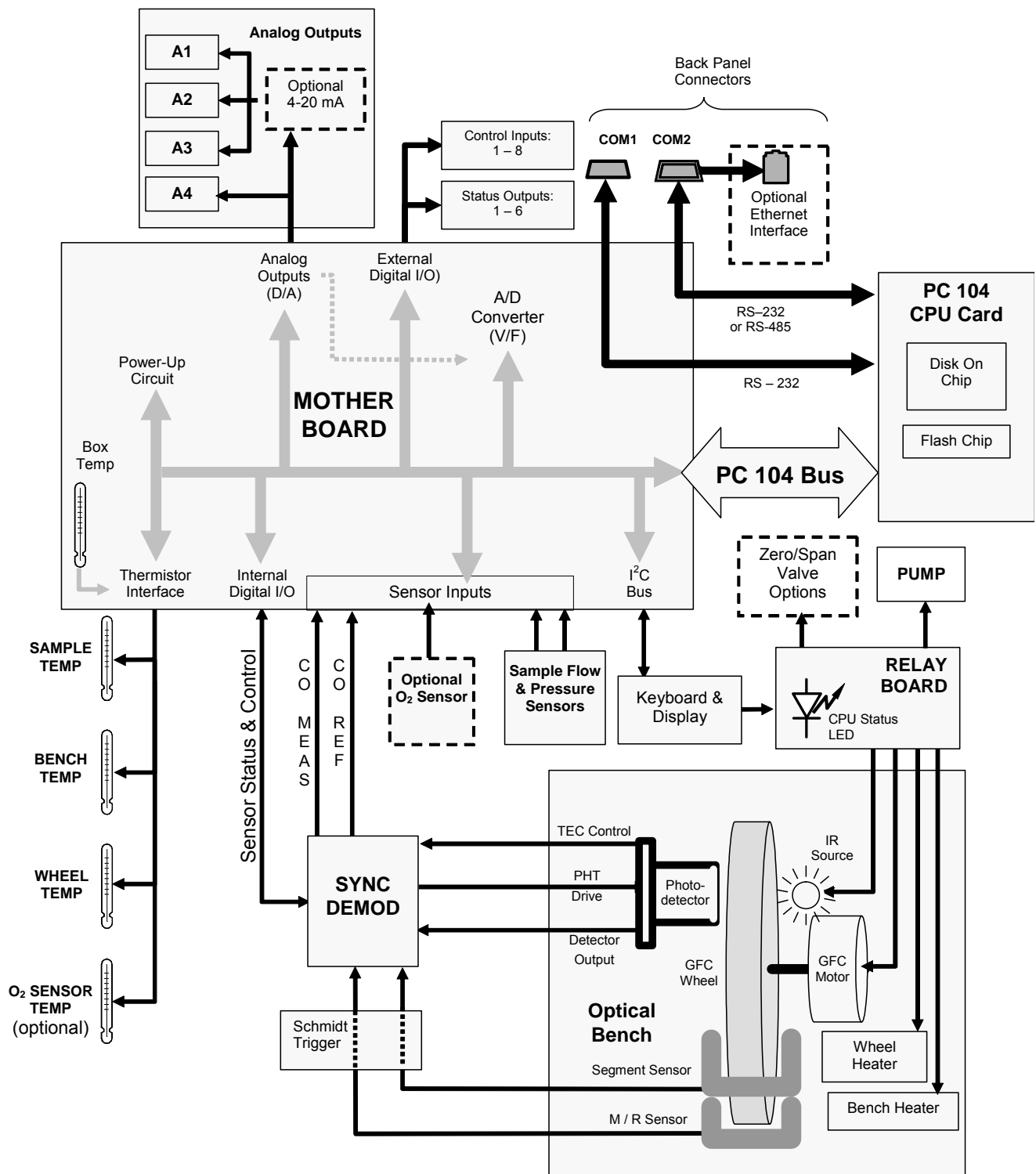

Figure 10-9: 360E Electronic Block Diagram

10.3.2. CPU

The Model 360E's CPU is a, low power (5 VDC, 0.8A max), high performance, 386-based microcomputer running MS-DOS. Its operation and assembly conform to the PC/104 Specification version 2.3 for embedded PC and PC/AT applications. It has 2 MB of DRAM on board and operates at 40MHz over an internal 32-bit data and address bus. Chip to chip data handling is performed by two 4-channel DMA devices over data busses of either 8-bit or 16-bit configuration. The CPU supports both RS-232 and RS-485 serial I/O.

The CPU includes two types of non-volatile data storage.

Disk-On-Chip

While technically an EEPROM, the Disk –on-Chip (DOC), this device appears to the CPU as, behaves as, and performs the same function in the system as an 8MB disk drive. It is used to store the operating system for the computer, the Teledyne Instruments Firmware, and most of the operational data generated by the analyzer's internal data acquisition system (iDAS - See Section 6.7).

Flash Chip

Another, smaller EEPROM used to store critical calibration and configuration data. Segregating this data on a separate, less heavily accessed chip significantly decreases the chance of this key data being corrupted.

10.3.3. Optical Bench & GFC Wheel

Electronically, the Model 360E's optical bench, GFC wheel and associated components do more than simply measure the amount of CO₂ present in the sample chamber. A variety of other critical functions are performed here as well.

10.3.3.1. Temperature Control

Because the temperature of a gas affects its density and therefore the amount of light absorbed by that gas it is important to reduce the effect of fluctuations in ambient temperature on the Model 360E's measurement of CO₂. To accomplish this both the temperature of the sample chamber and the GFC Wheel are maintained at constant temperatures above their normal operating ranges.

Bench Temperature: To minimize the effects of ambient temperature variations on the sample measurement, the sample chamber is heated to 48°C (8 degrees above the maximum suggested ambient operating temperature for the analyzer). A strip heater attached to the underside of the chamber housing is the heat source. The temperature of the sample chamber is sensed by a thermistor, also attached to the sample chamber housing.

Wheel Temperature: To minimize the effects of temperature variations caused by the near proximity of the IR Source to the GFC wheel on the gases contained in the wheel, it is also raised to a high temperature level. Because the IR Source itself is very hot, the set point for this heat circuit is 68°C. A cartridge heater implanted into the heat sync on the motor is the heat source. The temperature of the wheel/motor assembly is sensed by a thermistor also inserted into the heat sync.

Both heaters operate off of the AC line voltage supplied to the instrument.

10.3.3.2. IR Source

The light used to detect CO₂ in the sample chamber is generated by an element heated to approximately 1100°C producing infrared radiation across a broad band. This radiation is optically filtered after it has passed through the GFC Wheel and the sample chamber and just before it reaches the photo-detector to eliminate all black body radiation and other extraneous IR emitted by the various components of those components.

10.3.3.3. GFC Wheel

A synchronous AC motor turns the GFC wheel motor. For analyzers operating on 60Hz line power this motor turns at 1800 rpm. For those operating on 50Hz line power the spin rate is 1500 rpm. The actual spin rate is unimportant within a large rate since a phase lock loop circuit is used to generate timing pulses for signal processing.

In order to accurately interpret the fluctuations of the IR beam after it has passed through the sample gas, the GFC wheel several other timing signals are produced by other photo emitters/detectors. These devices consist of a combination LED and detector mounted so that the light emitted by the LED shines through the same mask on the GFC wheel that chops the IR beam.

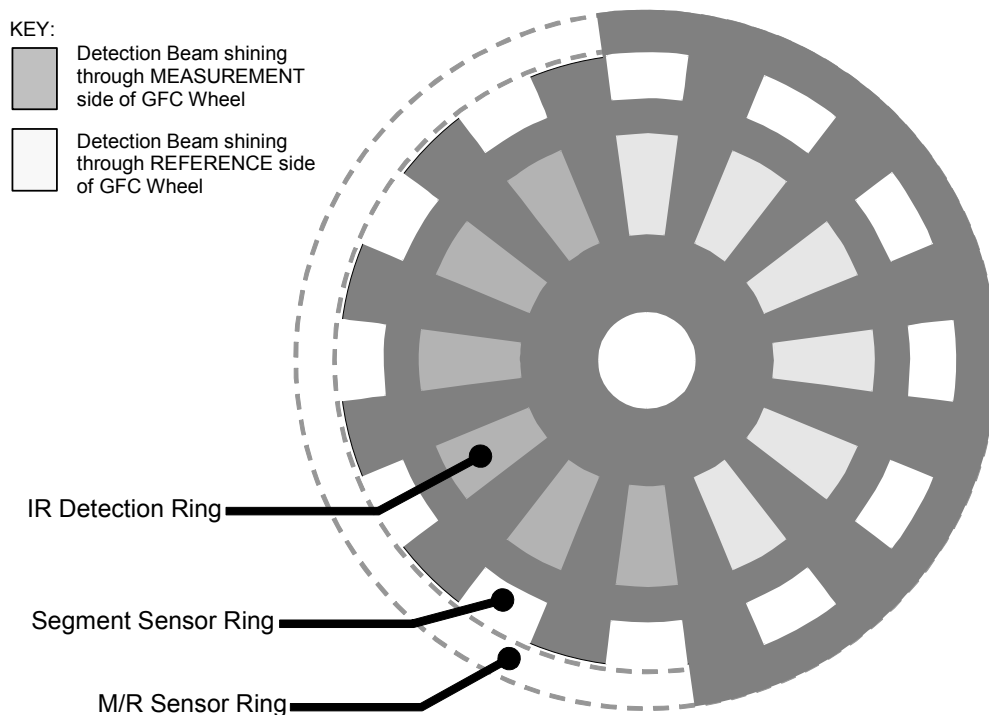

Figure 10-10: GFC Light Mask

M/R Sensor

This emitter/detector assembly that produces a signal that shines through a portion of the mask that allows light to pass for half of a full revolution of the wheel. The resulting light signal tells the analyzer whether the IR beam is shining through the measurement or the reference side of the GFC wheel.

Segment Sensor

Light from this emitter/detector pair shines through a portion of the mask that is divided into the same number of segments as the IR detector ring. It is used by the synchronous / demodulation circuitry of the analyzer to latch onto the most stable part of each measurement and reference IR pulse.

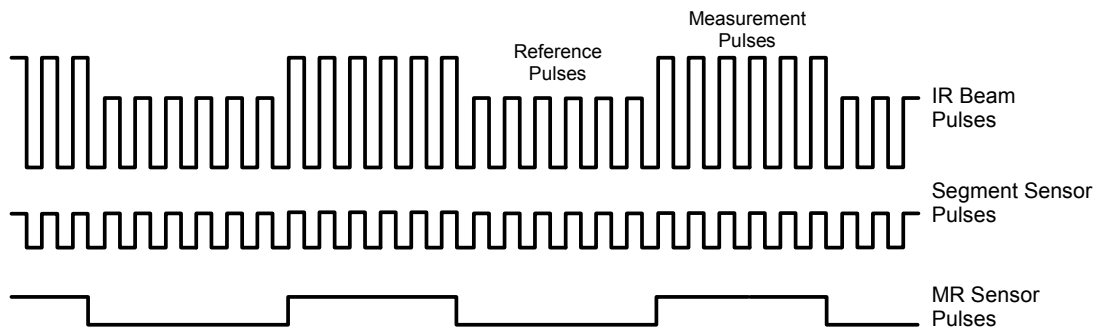

Figure 10-11: Segment Sensor and M/R Sensor Output

Schmidt Triggers

To ensure that the waveforms produced by the Segment Sensor and the M/R Sensor are properly shaped and clean, these signals are passed through a set of Schmidt Triggers circuits.

10.3.3.4. IR Photo-Detector

The IR beam is converted into an electrical signal by a cooled solid-state photo-conductive detector. The detector is composed of a narrow-band optical filter, a piece of lead-salt crystal whose electrical resistance changes with temperature, and a two-stage thermo-electric cooler.

When the analyzer is on, a constant electrical current is directed through the detector. The IR beam is focused onto the detector surface, raising its temperature and lowering its electrical resistance that results in a change in the voltage drop across the detector.

During those times that the IR beam is bright, the temperature of the detector is high; the resistance of the detector is correspondingly low and the its output voltage output is low. During those times when the IR beam intensity is low or completely blocked by the GFC Wheel mask, the temperature of the detector is lowered by the two-stage thermo-electric cooler, increasing the detectors resistance and raising the output voltage.

10.3.4. Synchronous Demodulator (Sync/Demod) Assembly

10.3.4.1. Overview

While the photo-detector converts fluctuations of the IR beam into electronic signals, the Sync / Demod Board amplifies these signals and converts them into usable information. Initially the output by the photo-detector is a complex and continuously changing waveform made up of Measure and Reference pulses. The sync/demod board demodulates this waveform and outputs two analog DC voltage signals, corresponding to the peak values of these pulses. **CO2 MEAS** and **CO2 REF** are converted into digital signals by circuitry on the motherboard then used by the CPU to calculate the CO₂ concentration of the sample gas.

Additionally the synch/demod board contains circuitry that controls the photo-detector's thermoelectric cooler as well as circuitry for performing certain diagnostic tests on the analyzer.

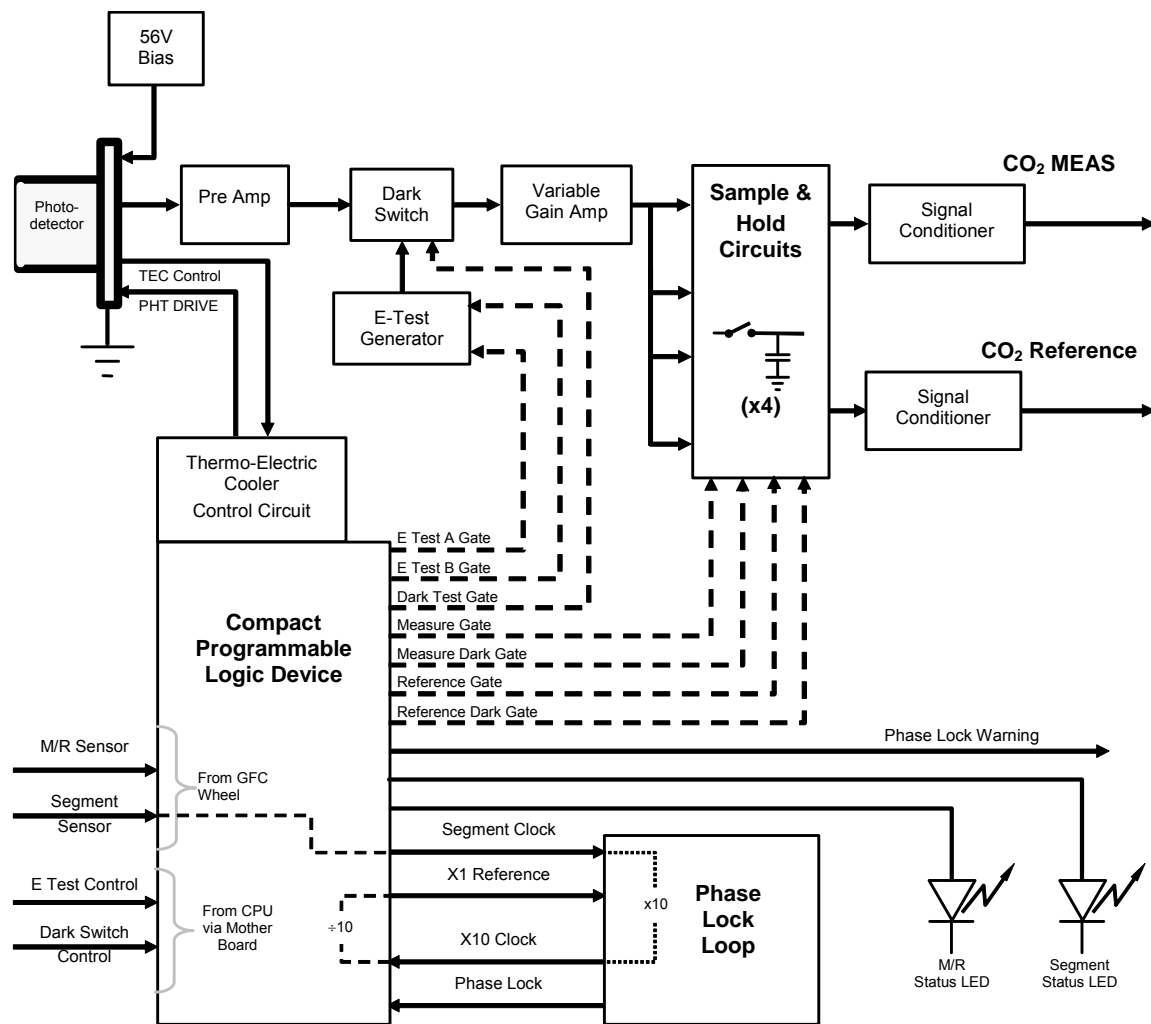

Figure 10-12: 360E Sync / Demod Block Diagram

10.3.4.2. Signal Synchronization and Demodulation

The signal emitted by the IR photo-detector goes through several stages of amplification before it can be accurately demodulated. The first is a pre-amplification stage that raises the signal to levels readable by the rest of the synch/demod board circuitry. The second is a variable amplification stage that is adjusted at the factory to compensate for performance variations of mirrors, detectors, and other components of the optical bench from instrument to instrument.

The workhorses of the synch/demod board are the four sample-and-hold circuits that capture various voltage levels found in the amplified detector signal needed to determine the value of **CO2 MEAS** and **CO2 REF**. They are activated by logic signals under the control of a compact programmable logic device (PLD), which in turn responds to the output of the Segment Sensor and M/R Sensor described in Figure 10–11.

The four sample and hold circuits are:

DESIGNATION	ACTIVE WHEN:	
	IR BEAM PASSING THROUGH	SEGMENT SENSOR PULSE IS:
Measure Gate	MEASUREMENT cell of GFC Wheel	HIGH
Measure Dark Gate	MEASUREMENT Cell of GFC Wheel	LOW
Reference Gate	REFERENCE cell of GFC Wheel	HIGH
Reference Dark Gate	REFERENCE cell of GFC Wheel	LOW

Timing for activating the Sample and Hold circuits is provided by a phase lock loop circuit (PLL). Using the segment sensor output as a reference signal the PLL generates clock signal at ten times that frequency. This faster clock signal is used by the PLD to make the sample and hold circuits capture the signal during the center portions of the detected waveform, ignore the rising and falling edges of the detector signal.

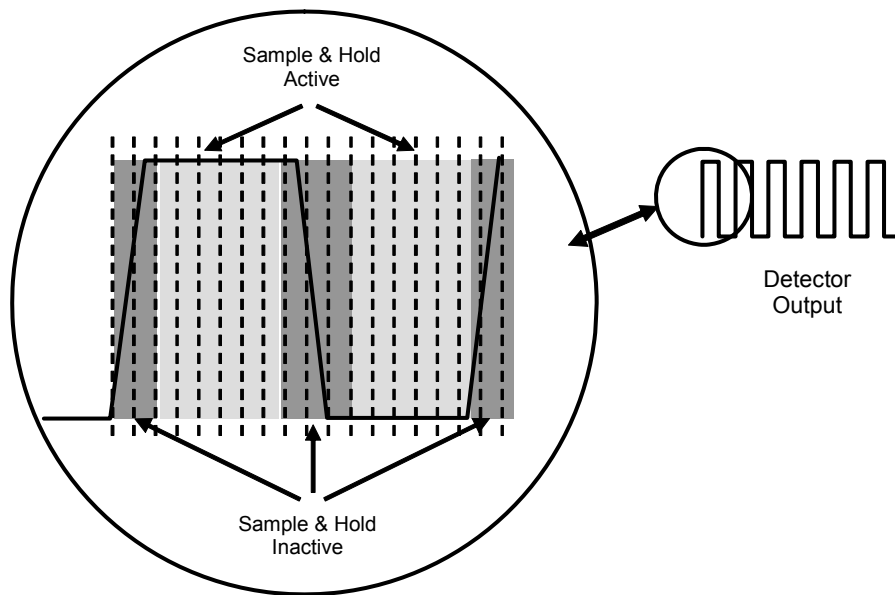

Figure 10-13: Sample & Hold Timing

10.3.4.3. Sync/Demod Status LED's

The following two status LED's located on the synch/demod board provide additional diagnostic tools for checking the GFC wheel rotation.

Table 10-1: Sync/Demod Status LED Activity

LED	FUNCTION	STATUS OK	FAULT STATUS
D1	M/R Sensor Status	LED flashes approximately 2/second	LED is stuck ON or OFF
D2	Segment Sensor Status	LED flashes approximately 6/second	LED is stuck ON or OFF

See Section 11.1.4 for more information.

10.3.4.4. Photo-Detector Temperature Control

The synch/demod board also contains circuitry that controls the IR photo-detector's thermoelectric coolers. A drive voltage, **PHT DRIVE**, is supplied to the coolers by the synch/demod board which is adjusted by the synch/demod board based on a return signal called TEC control which alerts informs the synch/demod board of the detector's temperature. The warmer the detector, the harder the coolers are driven.

PHT DRIVE is one of the Test Functions viewable by the user via the front panel. Press **<TST or TST>** until it appears on the display.

10.3.4.5. Dark Calibration Switch

This switch initiates the Dark Calibration procedure. When initiated by the user (See Section 6.13.6 for more details), the dark calibration process opens this switch, interrupting the signal from the IR photo-detector. This allows the analyzer to measure any offset caused by the synch/demod board circuitry.

10.3.4.6. Electric Test Switch

When active this circuit generates a specific waveform intended to simulate the function of the IR photo-detector but with a known set of value which is substituted for the detector's actual signal via the dark switch. It may also be initiated by the user (See Section 6.13.5 for more details).

10.3.5. Relay Board

By actuating various switches and relays located on this board, the CPU controls the status of other key components. The relay board receives instructions in the form of digital signals over the I²C bus, interprets these digital instructions and activates its various switches and relays appropriately.

Heater Control

The two heaters attached to the sample chamber housing and the GFC wheel motor are controlled by solid state relays located on the relay board.

The GFC wheel heater is simply turned on or off, however control of the bench heater also includes circuitry that selects which one of its two separate heating elements is activated depending on whether the instrument is running on 100 VAC, 115 VAC or 230 VAC line power.

GFC Wheel Motor Control:

The GFC wheel operates from an AC voltage supplied by a multi-input transformer located on the relay board. The step-down ratio of this transformer is controlled by factory-installed jumpers to adjust for 100 VAC, 115 VAC or 230 VAC line power. Other circuitry slightly alters the phase of the AC power supplied to the motor during start up based on whether line power is 50Hz or 60 Hz.

Normally, the GFC Wheel Motor is always turning while the analyzer is on. A physical switch located on the relay board can be used to turn the motor off for certain diagnostic procedures.

Zero/Span Valve Options

Any zero/span/shutoff valve options installed in the analyzer are controlled by a set of electronic switches located on the relay board. These switches, under CPU control, supply the +12VDC needed to activate each valve's solenoid.

IR Source

The Relay board supplies a constant 11.5VDC to the IR Source. Under normal operation the IR source is always on.

10.3.5.1. Status LED's

Eight LED's are located on the analyzer's relay board to show the current status on the various control functions performed by the relay board (see Figure 10-14). They are:

Table 10-2: Relay Board Status LED's

LED	COLOR	FUNCTION	STATUS WHEN LIT	STATUS WHEN UNLIT
D1	RED	Watchdog Circuit	Cycles On/Off Every 3 Seconds under direct control of the analyzer's CPU.	
D2	YELLOW	Wheel Heater	HEATING	NOT HEATING
D3	YELLOW	Bench Heater	HEATING	NOT HEATING
D4	YELLOW	Spare	N/A	N/A
D5	GREEN	Sample/Cal Gas Valve Option	Valve Open to CAL GAS FLOW	Valve Open to SAMPLE GAS FLOW
D6	GREEN	Zero/Span Gas Valve Option	Valve Open to SPAN GAS FLOW	Valve Open to ZERO GAS FLOW
D7	GREEN	Shutoff Valve Option	Valve Open to CAL GAS FLOW	Valve CLOSED to CAL GAS FLOW
D8	GREEN	IR SOURCE	Source ON	Source OFF

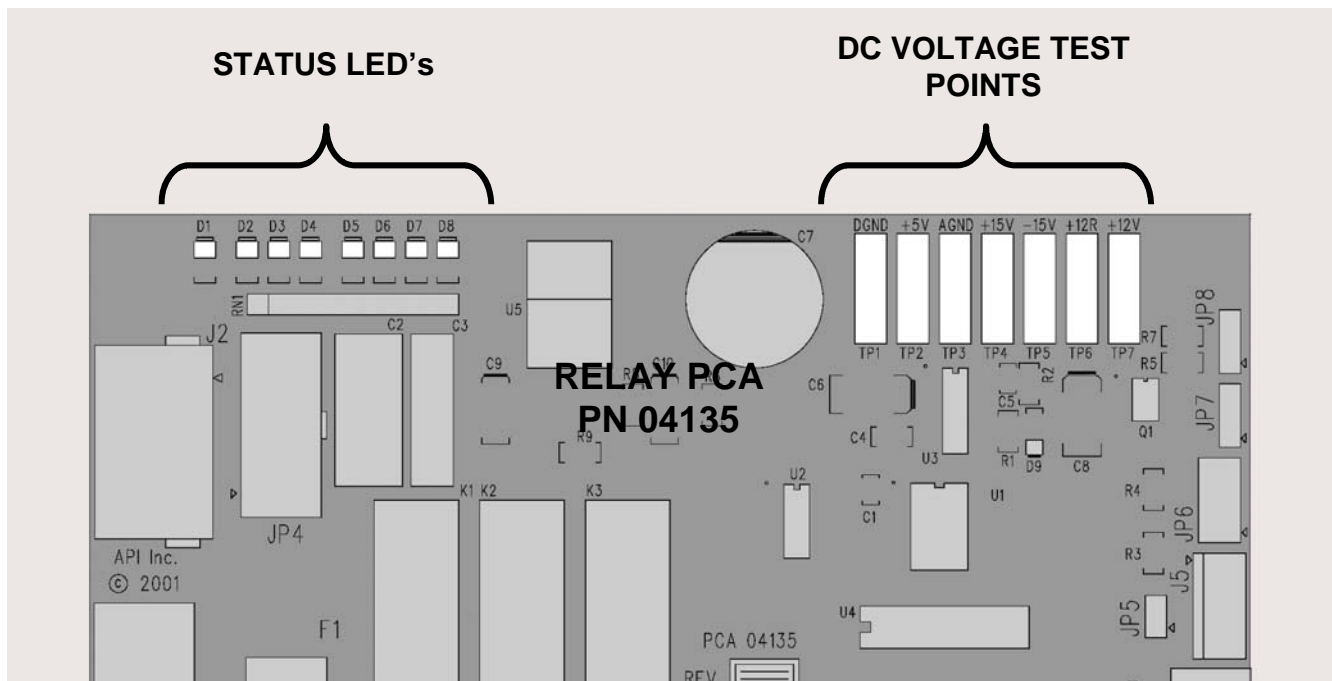

Figure 10-14: Location of relay board Status LED's

10.3.5.2. I²C Watch Dog Circuitry

Special circuitry on the relay board monitors the activity on the I²C bus and drives LED D1. Should this LED ever stay **ON** or **OFF** for 30 seconds, the watchdog circuit will automatically shut off all valves as well as turn off the IR Source and all heaters. The GFC wheel motor will still be running as will the Sample Pump, which is not controlled by the relay board.

10.3.6. Mother Board

This printed circuit assembly provides a multitude of functions including, A/D conversion, digital input/output, PC-104 to I2C translation, temperature sensor signal processing and is a pass through for the RS-232 and RS-485 signals.

10.3.6.1. A to D Conversion

Analog signals, such as the voltages received from the analyzer's various sensors, are converted into digital signals that the CPU can understand and manipulate by the analog to digital converter (A/D). Under the control of the CPU, this functional block selects a particular signal input (e.g. **BOX TEMP**, **CO2 MEAS**, **CO2 REF**, etc.) and then converts the selected voltage into a digital word.

The A/D consists of a voltage-to-frequency (V-F) converter, a programmable logic device (PLD), three multiplexers, several amplifiers and some other associated devices. The V-F converter produces a frequency proportional to its input voltage. The PLD counts the output of the V-F during a specified time period, and sends the result of that count, in the form of a binary number, to the CPU.

The A/D can be configured for several different input modes and ranges but in the M360E is used in uni-polar mode with a +5 V full scale. The converter includes a 1% over and under-range. This allows signals from -0.05 V to +5.05 V to be fully converted.

For calibration purposes, two reference voltages are supplied to the A/D converter: Reference Ground and +4.096 VDC. During calibration, the device measures these two voltages, outputs their digital equivalent to the CPU. The CPU uses these values to compute the converter's offset and slope and uses these factors for subsequent conversions.

See Section 6.13.4 for instructions on performing this calibration.

10.3.6.2. Sensor Inputs

The key analog sensor signals are coupled to the A/D through the master multiplexer from two connectors on the motherboard. 100K terminating resistors on each of the inputs prevent cross talk from appearing on the sensor signals.

Co₂ Measure And Reference

These are the primary signals that are used in the computation of the CO₂ concentration. They are the demodulated IR-sensor signals from the sync demodulator board.

Sample Pressure And Flow

These are analog signals from two sensors that measure the pressure and flow rate of the gas stream at the outlet of the sample chamber. This information is used in two ways. First, the sample pressure is used by the CPU to calculate CO₂ Concentration. Second, the pressure and flow rate are monitored as a test function to assist the user in predicting and troubleshooting failures.

10.3.6.3. Thermistor Interface

This circuit provides excitation, termination and signal selection for several negative-coefficient, thermistor temperature sensors located inside the analyzer. They are:

Sample Temperature Sensor

The source of this signal is a thermistor located inside the sample chamber of the Optical Bench. It measures the temperature of the sample gas in the chamber. This data is used during the calculation of the CO₂ concentration value.

Bench Temperature Sensor

This thermistor, attached to the sample chamber housing, reports the current temperature of the chamber housing to the CPU as part of the bench heater control loop.

Wheel Temperature Sensor

This thermistor (attached to the heat-sync on the GFC wheel motor assembly) reports the current temperature of the wheel/motor assembly to the CPU as part of the Wheel Heater control loop.

Box Temperature Sensor

A thermistor is attached to the motherboard. It measures the analyzer's inside temperature. This information is stored by the CPU and can be viewed by the user for troubleshooting purposes via the front panel display (See Section 11.1.2).

10.3.6.4. Analog Outputs

The analyzer comes equipped with four analog outputs: A1, A2, A3 and A4. . In its standard configuration, the analyzer comes with all four of these channels set up to output a DC voltage. However, 4-20mA current loop drivers can be purchased for the first three of these outputs: A2, A2 & A3.

A2 and A1 Output

The first two, A2 and A1 are normally set up to operate in parallel so that the same data can be sent to two different recording devices. While the names imply that one should be used for sending data to a chart recorder and the other for interfacing with a data logger, either can be used for both applications.

Both of these channels output a signal that is proportional to the CO₂ concentration of the sample gas. The A1 and A2 outputs can be slaved together or set up to operate independently. A variety of scaling factors are available. See Section 6.13.4 for information on setting the range type and scaling factors for these output channels.

A3 Output

Analog output channel **A3** is only active when the O₂ sensor option is installed in the M360E. In this case, the currently measured O₂ concentration is output.

Test Function Output

The fourth analog output, labeled **A4** is special. It can be set by the user (See Section 6.9.9) to carry the current signal level of any one of the parameters accessible through the **SETUP → MORE → DIAG → TEST CHAN OUTPUT** submenu (See Section 6.13.9) of the unit's software.

Output Loop-back

All four analog outputs are connected back to the A/D converter through a Loop-back circuit. This permits the voltage outputs to be calibrated by the CPU without need for any additional tools or fixtures.

10.3.6.5. Internal Digital I/O

This channel is used to communicate digital status and control signals about the operation of key components of the Optical Bench. The CPU sends signals to the synch/demod board that initiate the **ELECTRICAL TEST** and **DARK CALIBRATION** procedures. Likewise, the synch/demod board uses this interface to send the **SYNC** warning signal to the CPU (See Sections 6.9.5, 6.9.6 and 11.1.1).

10.3.6.6. External Digital I/O

This External Digital I/O performs two functions.

Status Outputs

Logic-Level voltages are output through an optically isolated 8-pin connector located on the rear panel of the analyzer. These outputs convey good/bad and on/off information about certain analyzer conditions. They can be used to interface with certain types of programmable devices (See Section 6.13.1.1).

Control Inputs

By applying +5VDC power supplied from an external source such as a PLC or Data logger (See Section 6.13.1.2), Zero and Span calibrations can be initiated by contact closures on the rear panel.

10.3.7. I²C Data Bus

An I²C data bus is used to communicate data and commands between the CPU and the keyboard/display interface and the relay board. I²C is a two-wire, clocked, digital serial I/O bus that is used widely in commercial and consumer electronic systems. A transceiver on the motherboard converts data and control signals from the PC-104 bus to I²C. The data is then fed to the keyboard/display interface and finally onto the relay board.

Interface circuits on the keyboard/display interface and relay boards convert the i²c data to parallel inputs and outputs. An additional, interrupt line from the keyboard to the motherboard allows the CPU to recognize and service key presses on the keyboard.

Power up Circuit

This circuit monitors the +5V power supply during start-up and sets the Analog outputs, external digital I/O ports, and I²C circuitry to specific values until the CPU boots and the instrument software can establish control.

10.3.8. Power Supply/ Circuit Breaker

The analyzer operates on 100 VAC, 115 VAC or 230 VAC power at either 50Hz or 60Hz. Individual units are set up at the factory to accept any combination of these five attributes. As illustrated in Figure 10-15, power enters the analyzer through a standard IEC 320 power receptacle located on the rear panel of the instrument. From there it is routed through the On/Off switch located in the lower right corner of the Front Panel. A 6.75 Amp circuit breaker is built into the ON/OFF Switch.

AC power is distributed directly to the sample gas pump. The bench and GFC wheel heaters as well as the GFC wheel receive AC power via the relay board.

AC Line power is converted stepped down and converted to DC power by two DC power supplies. One supplies +12 VDC, for valves and the IR source, while a second supply provides +5 VDC and ± 15 VDC for logic and analog circuitry. All DC voltages are distributed via the relay board.

	<p>CAUTION</p> <p>Should the AC power circuit breaker trip, investigate and correct the condition causing this situation before turning the analyzer back on.</p>
---	--

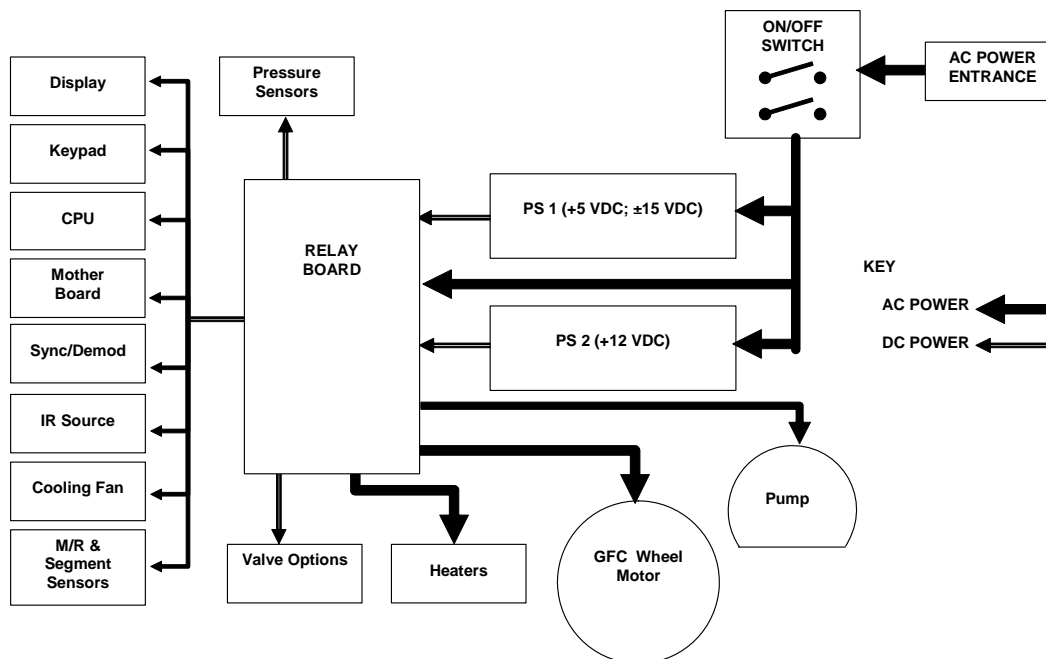

Figure 10-15: Power Distribution Block Diagram

10.4. Interface

The analyzer has several ways to communicate the outside world, see Figure 10-16. Users can input data and receive information directly via the Front panel keypad and display. Direct communication with the CPU is also available by way of the analyzer's RS232 & RS485 I/O ports or an optional Ethernet port. The analyzer can also send and receive different kinds of information via its external digital I/O connectors and the three analog outputs located on the rear panel.

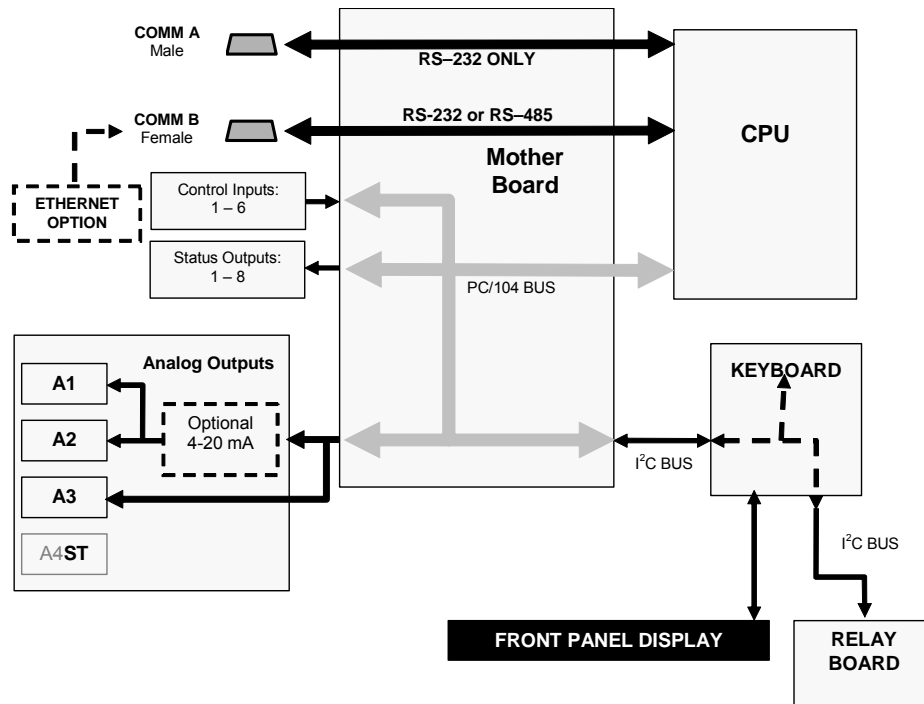

Figure 10-16: Interface Block Diagram

10.4.1. Front Panel Interface

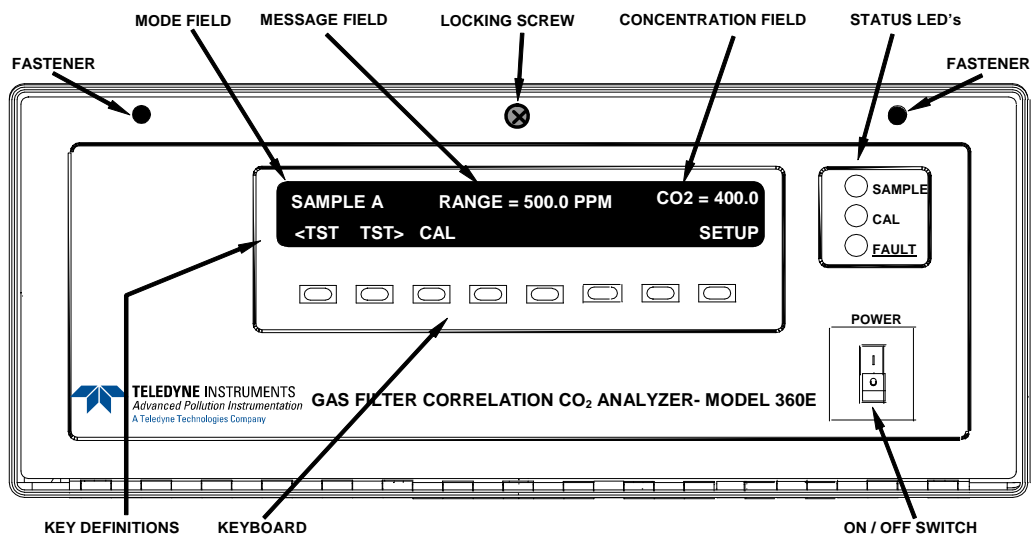

Figure 10-17: M360E Front Panel Layout

The most commonly used method for communicating with the M360E Analyzer is via the instrument's front panel which includes a set of three status LEDs, a vacuum florescent display and a keyboard with 8 context sensitive keys.

10.4.1.1. Analyzer Status LED's

Three LEDs are used to inform the user of the instruments basic operating status

Table 10-3: Front Panel Status LED's

NAME	COLOR	STATE	DEFINITION
SAMPLE	Green	Off	Unit is not operating in sample mode, iDAS is disabled.
		On	Sample Mode active; Front Panel Display being updated, iDAS data being stored.
		Blinking	Unit is operating in sample mode, front panel display being updated, iDAS hold-off mode is ON, iDAS disabled
CAL	Yellow	Off	Auto Cal disabled
		On	Auto Cal enabled
		Blinking	Unit is in calibration mode
FAULT	Red	Off	CO ₂ warnings exist
		Blinking	Warnings exist

10.4.1.2. Keyboard

A row of eight keys just below the vacuum florescent display (see Figure 10-17) is the main method by which the user interacts with the analyzer. As the software is operated, labels appear on the bottom row of the display directly above each active key, defining the function of that key as it is relevant for the operation being performed. Pressing a key causes the associated instruction to be performed by the analyzer.

Note that the keys do not auto-repeat. In circumstances where the same key must be activated for two consecutive operations, it must be released and re-pressed.

10.4.1.3. Display

The main display of the analyzer is a vacuum florescent display with two lines of 40 text characters each. Information is organized in the following manner (see Figure 10-17):

Mode Field: Displays the name of the analyzer's current operating mode.

Message Field: Displays a variety of informational messages such as warning messages, operation data and response messages during interactive tasks.

Concentration Field: Displays the actual concentration of the sample gas currently being measured by the analyzer

Keypad Definition Field: Displays the definitions for the row of keys just below the display. These definitions dynamic, context sensitive and software driven.

10.4.1.4. Keyboard/Display Interface Electronics

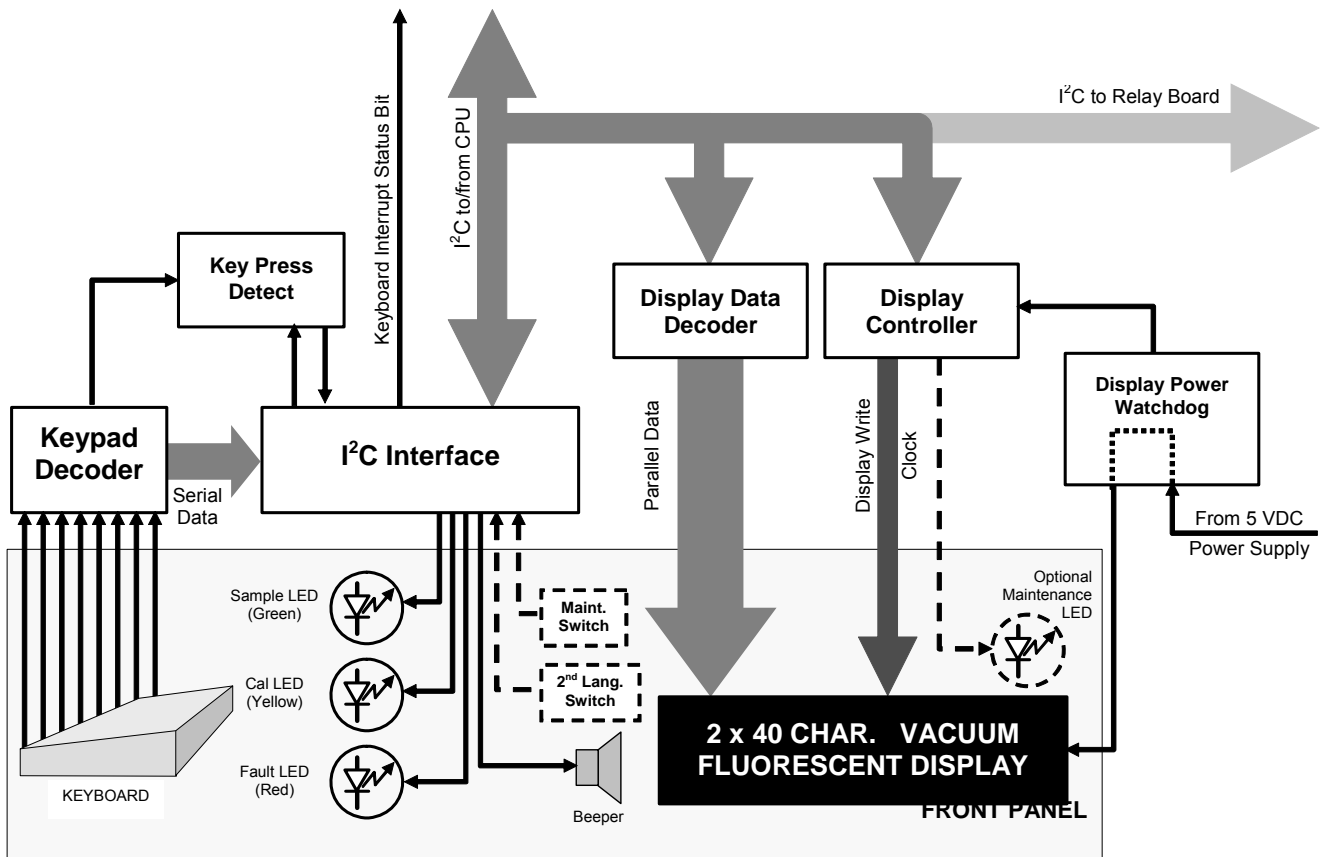

Figure 10-18: Keyboard and Display Interface Block Diagram

The keyboard/display interface electronics of the M360E Analyzer watches the status of the eight front panel keys, alerts the CPU when keys are depressed, translates data from parallel to serial and back and manages communications between the keyboard, the CPU and the front panel display. Except for the Keyboard interrupt status bit, all communication between the CPU and the keyboard/display is handled by way of the instrument's I²C buss. The CPU controls the clock signal and determines when the various devices on the bus are allowed to talk or required to listen. Data packets are labeled with addresses that identify for which device the information is intended.

KEYPAD DECODER

Each key on the front panel communicates with a decoder IC via a separate analog line. When a key is depressed the decoder chip notices the change of state of the associated signal; latches and holds the state of all eight lines (in effect creating an 8-bit data word); alerts the key-depress-detect circuit (a flip-flop IC); translates the 8-bit word into serial data and; sends this to the I²C interface chip.

KEY-DEPRESS-DETECT CIRCUIT

This circuit flips the state of one of the inputs to the I²C interface chip causing it to send an interrupt signal to the CPU

I²C INTERFACE CHIP

This IC performs several functions:

- Using a dedicated digital status bit, it sends an interrupt signal alerting the CPU that new data from the keyboard is ready to send.
- Upon acknowledgement by the CPU that it has received the new keyboard data, the I²C interface chip resets the key-depress-detect flip-flop.
- In response to commands from the CPU, it turns the front panel status LEDs on and off and activates the beeper.
- Informs the CPU when the optional maintenance and second language switches have been opened or closed (see Chapter 5 for information on these options).

DISPLAY DATA DECODER

This decoder the serial translates the data sent by the CPU (in TTY format) into a bitmapped image which is sent over a parallel data bus to the display.

DISPLAY CONTROLLER

This circuit manages the interactions between the display data decoder and the display itself. It generates a clock pulse that keeps the two devices synchronized. It can also, in response to commands from the CPU turn off and/or reset the display.

Additionally, for analyzers with the optional maintenance switch is installed (See Chapter 5), the display controller turns on an LED located on the back of the keyboard interface PCA whenever the instrument is placed in maintenance mode.

DISPLAY POWER WATCHDOG

The Model 360E's display can begin to show garbled information or lock-up if the DC voltage supplied to it falls too low, even momentarily. To alleviate this, a brown-out watchdog circuit monitors the level of the power supply and in the event that the voltage level falls below a certain level, turns the display off, then on resetting it

I²C LINK TO THE RELAY PCA

While the CPU's I²C communication with the relay board is also routed through the keyboard/display interface, information passed to and from the relay board via this channel is not recognized by, acted upon or affected by the circuitry of the keyboard/display interface.

10.5. Software Operation

The Model 360E Gas Filter Correlation Carbon Dioxide Analyzer is at its heart a high performance, 386-based microcomputer running MS-DOS. Inside the DOS shell, special software developed by Teledyne Instruments interprets user commands via the various interfaces, performs procedures and tasks, stores data in the CPU's various memory devices and calculates the concentration of the sample gas.

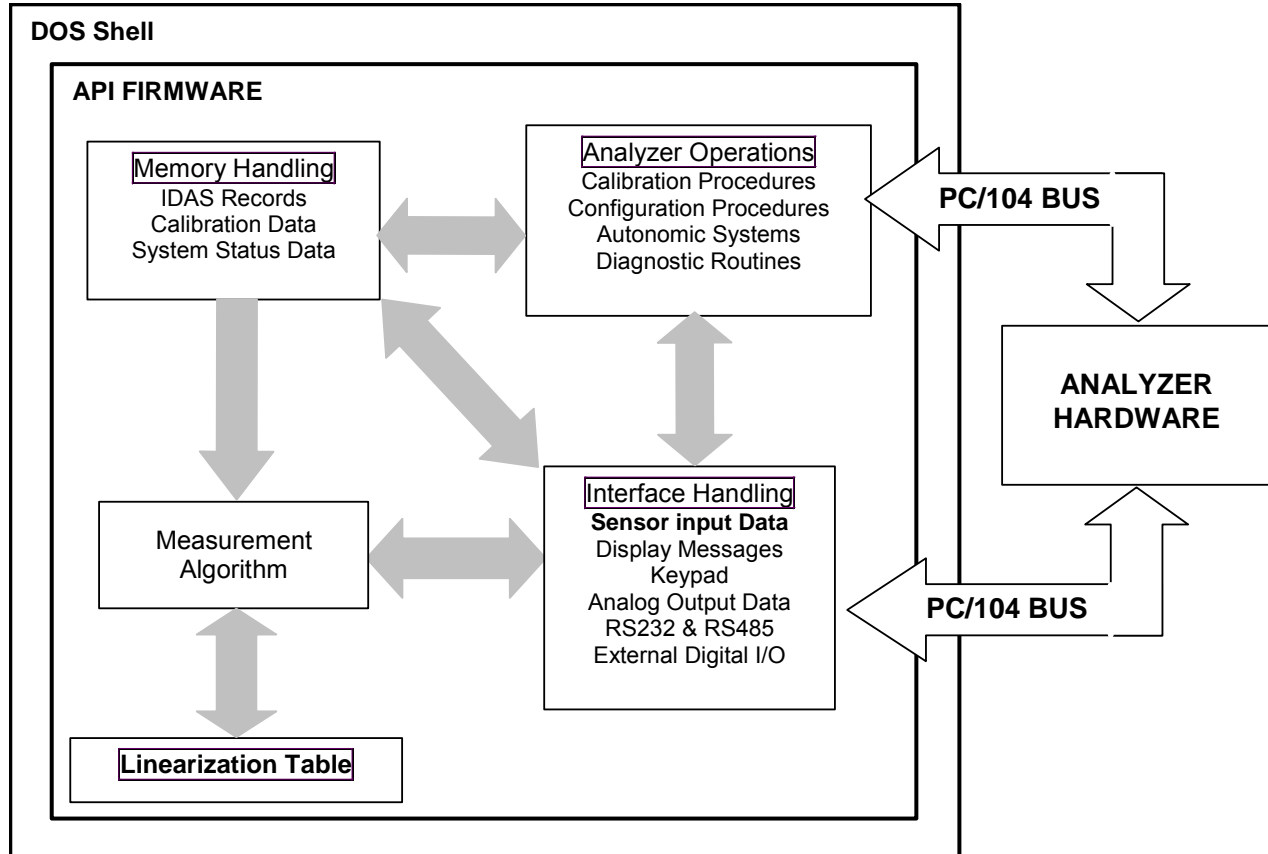

Figure 10-19: Basic Software Operation

10.5.1. Adaptive Filter

The M360E software processes the **CO2 MEAS** and **CO2 REF** signals, after they are digitized by the motherboard, through an adaptive filter built into the software. Unlike other analyzers that average the output signal over a fixed time period, the M360E averages over a set number of samples, where each sample is 0.2 seconds. This technique is known as boxcar averaging. During operation, the software automatically switches between two different length filters based on the conditions at hand. Once triggered, the short filter remains engaged for a fixed time period to prevent chattering.

During conditions of constant or nearly constant concentration the software, by default, computes an average of the last 750 samples, or approximately 150 seconds. This provides the calculation portion of the software with smooth stable readings. If a rapid change in concentration is detected the filter includes, by default, the last 48 samples, approximately 10 seconds of data, to allow the analyzer to more quickly respond. If necessary, these boxcar lengths can be changed between 1 and 1000 samples but with corresponding tradeoffs in rise time and signal-to-noise ratio (contact customer service for more information).

Two conditions must be simultaneously met to switch to the short filter. First the instantaneous concentration must exceed the average in the long filter by a fixed amount. Second the instantaneous concentration must exceed the average in the long filter by a portion, or percentage, of the average in the long filter.

10.5.2. Calibration - Slope and Offset

Calibration of the analyzer is performed exclusively in software.

During instrument calibration (see Chapter 7) the user enters expected values for zero and span via the front panel keypad and commands the instrument to make readings of calibrated sample gases for both levels. The readings taken are adjusted, linearized, and compared to the expected values. With this information the software computes values for instrument slope and offset and stores these values in memory for use in calculating the CO₂ concentration of the sample gas.

The instrument slope and offset values recorded during the last calibration can be viewed by pressing the following keystroke sequence:

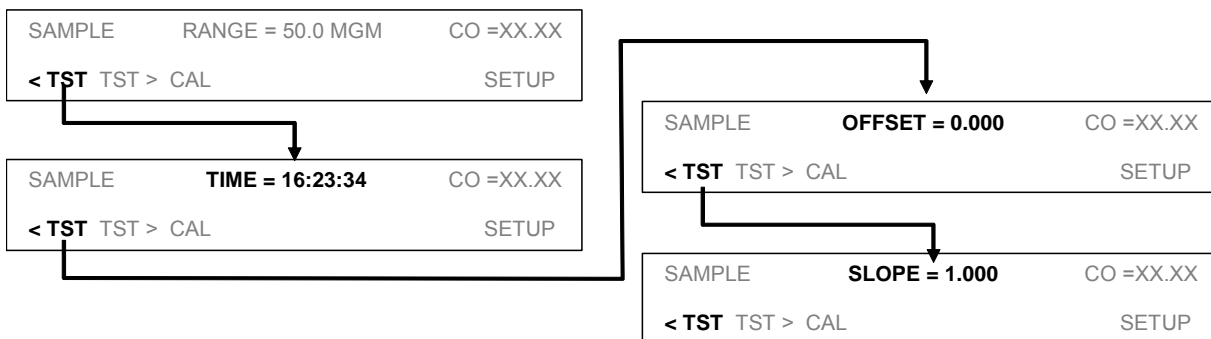

10.5.3. Measurement Algorithm

Once the IR photo-detector is signal is demodulated into **CO₂ MEAS** and **CO₂ REF** by the sync/demod board and converted to digital data by the motherboard the M360E analytical software calculates the ratio between **CO₂ MEAS** and **CO₂ REF**. This value is compared to a look-up table is used, with interpolation, to linearize the response of the instrument. The linearized concentration value is combined with calibration slope and offset values, then normalized for changes in sample gas pressure to produce the final CO₂ concentration. This is the value that is displayed on the instrument front panel display and is stored in memory by the analyzer's iDAS system.

10.5.4. Temperature and Pressure Compensation

Changes in pressure can have a noticeable, effect on the CO₂ concentration calculation. To account for this, the Model 360E software includes a feature which allows the instrument to compensation of the CO₂ calculations based on changes in ambient pressure.

The TPC feature multiplies the analyzer's CO₂ concentration by a factor which is based on the difference between the ambient pressure of the sample gas normalized to standard atmospheric pressure. As ambient pressure increases, the compensated CO₂ concentration is increased.

10.5.5. Internal Data Acquisition System (iDAS)

The iDAS is designed to implement predictive diagnostics that stores trending data for users to anticipate when an instrument will require service. Large amounts of data can be stored in non-volatile memory and retrieved in plain text format for further processing with common data analysis programs. The iDAS has a consistent user interface in all Teledyne Instruments analyzers. New data parameters and triggering events can be added to the instrument as needed.

Depending on the sampling frequency and the number of data parameters the iDAS can store several months of data, which are retained even when the instrument is powered off or a new firmware is installed. The iDAS permits users to access the data through the instrument's front panel or the remote interface. The latter can automatically download stored data for further processing. For information on using the iDAS, refer to Sections 6.12.

User Notes

11. TROUBLESHOOTING & REPAIR PROCEDURES

This contains a variety of methods for identifying the source of performance problems with the analyzer. Also included in this are procedures that are used in repairing the instrument.



CAUTION

The operations outlined in this chapter are to be performed by qualified maintenance personnel only.



CAUTION

Risk of electrical shock. Disconnect power before performing the following operations.

11.1. General Troubleshooting Hints

The analyzer has been designed so that problems can be rapidly detected, evaluated and repaired. During operation, the analyzer continuously performs self-check diagnostics and provides the ability to monitor the key operating parameters of the instrument without disturbing monitoring operations.

A systematic approach to troubleshooting will generally consist of the following four steps:

1. Note any **WARNING MESSAGES** and take corrective action as required.
2. Examine the values of all **TEST** functions and compare to factory values. Note any major deviations from the factory values and take correction action as required.
3. Use the internal electronic status LED's to determine whether the CPU and I²C buses are running, and if the sync/demodulator and relay board are operating properly. Verify that the DC power supplies are operating properly by checking the voltage test points on the relay board. Please note that the analyzer's DC power wiring is color-coded and these colors match the color of the corresponding test points on the relay board.
4. **SUSPECT A LEAK FIRST!** Data from Teledyne Instruments' service department indicates that 50% of all problems are eventually traced to leaks in the pneumatic connections and gas lines of the analyzer itself, the source of zero air, span gases or sample gas delivery system.

Check for gas flow problems such as clogged or blocked internal/external gas lines, damaged seals, punctured gas lines, a damaged pump diaphragm, etc.

5. Follow the procedures defined in Section 11.5 for confirming that the analyzer's basic components are working (power supplies, CPU, relay board, sync/demod board, keypad, GFC wheel motor, etc.). See Figure 3-3 for general layout of components and sub-assemblies in the analyzer. See the wiring Interconnect Drawing and Interconnect List, documents 04216 and 04217.

11.1.1. Interpreting WARNING Messages

The most common and/or serious instrument failures will result in a warning message being displayed on the front panel. Table 11-1 lists warning messages, along with their meaning and recommended corrective action.

It should be noted that if more than two or three warning messages occur at the same time, it is often an indication that some fundamental analyzer sub-system (power supply, relay board, motherboard) has failed rather than indication of the specific failures referenced by the warnings. In this case, it is recommended that proper operation of power supplies (See Section 11.5.2), the relay board (See Section 11.5.5), and the A/D Board (See Section 11.4.7.1) be confirmed before addressing the specific warning messages.

The analyzer will alert the user that a Warning Message is active by displaying the keypad label **MSG** on the Front Panel. In this case the Front panel display will look something like the following:



The analyzer will also alert the user via the Serial I/O COM port(s) and cause the FAULT LED on the front panel to blink.

To view or clear the various warning messages press:

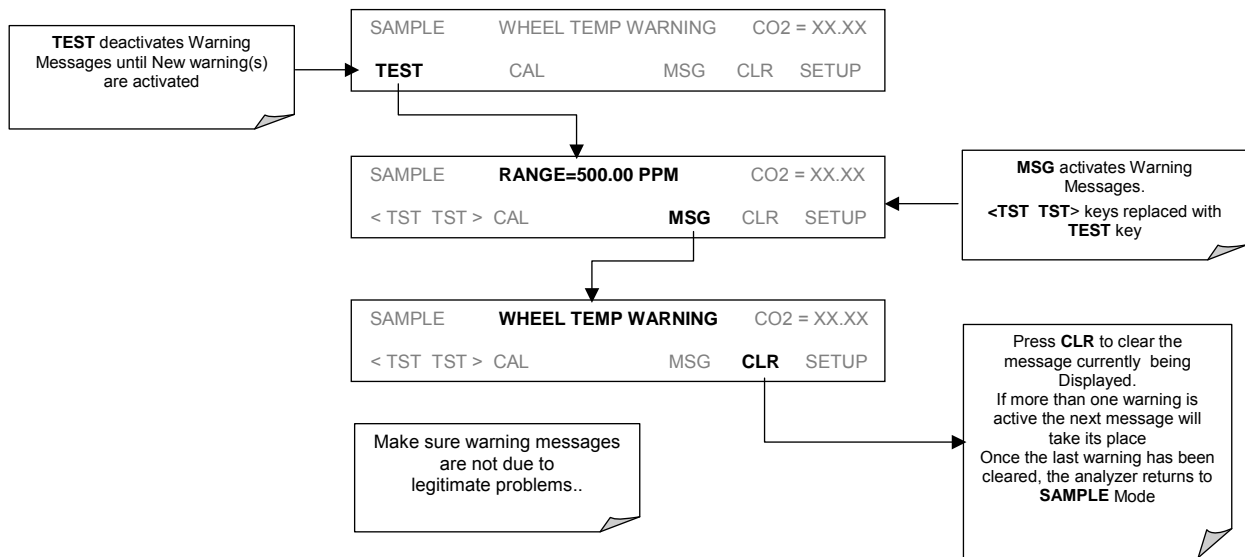

Figure 11-1: Viewing and Clearing Warning Messages

Table 11-1: Warning Messages - Indicated Failures

WARNING MESSAGE	FAULT CONDITION	POSSIBLE CAUSES
BENCH TEMP WARNING	The optical bench temp is controlled at 48 ± 2 °C.	Bad bench heater Bad bench temperature sensor Bad relay controlling the bench heater Entire relay board is malfunctioning I ² C buss malfunction
BOX TEMP WARNING	Box Temp is < 5 °C or > 48 °C.	NOTE: Box temperature typically runs ~7°C warmer than ambient temperature. Poor/blocked ventilation to the analyzer. Stopped exhaust-fan Ambient temperature outside of specified range
CANNOT DYN SPAN	Dynamic Span operation failed	Measured concentration value is too high or low. Concentration slope value too high or too low
CANNOT DYN ZERO	Dynamic Zero operation failed	Measured concentration value is too high. Concentration offset value too high.
CONFIG INITIALIZED	Configuration and Calibration data reset to original Factory state.	Failed disk on chip User erased data
CONC ALRM1 WARNING	Concentration alarm 1 is enabled and the measured CO ₂ level is ≥ the set point.	
CONC ALRM2 WARNING	Concentration alarm 2 is enabled and the measured CO ₂ level is ≥ the set point.	
DATA INITIALIZED	Data Storage in iDAS was erased	Failed disk on chip User cleared data
FRONT PANEL WARN	The CPU is unable to Communicate with the Front Panel Display /Keyboard	Warning only appears on serial I/O com port(s) Front panel display will be frozen, blank or will not respond. Failed keyboard I ² C buss failure Loose connector/wiring
PHOTO TEMP WARNING	PHT DRIVE is >4800 mVDC	Failed IR photo-detector Failed sync/demod board IR photo-detector improperly attached to the sample chamber Bench temp too high.
REAR BOARD NOT DET	Mother Board not detected on power up.	Warning only appears on serial i/o com port(s) Front panel display will be frozen, blank or will not respond. Massive failure of mother board
RELAY BOARD WARN	The CPU cannot communicate with the Relay Board.	I ² C buss failure Failed relay board Loose connectors/wiring
SAMPLE FLOW WARN	Sample flow rate is < 500 cc/min or > 1000 cc/min.	Failed sample pump Blocked sample inlet/gas line Dirty particulate filter Leak downstream of critical flow orifice Failed flow sensor/circuitry
SAMPLE PRES WARN	Sample Pressure is <10 in-Hg or > 35 in-Hg Normally 29.92 in-Hg at sea level decreasing at 1 in-Hg per 1000 ft of altitude (with no flow – pump disconnected).	If sample pressure is < 10 in-hg: <ul style="list-style-type: none"> o Blocked particulate filter o Blocked sample inlet/gas line o Failed pressure sensor/circuitry If sample pressure is > 35 in-hg: <ul style="list-style-type: none"> o Pressurized sample gas. Install vent o Blocked vent line on pressurized sample/zero/span gas supply o Bad pressure sensor/circuitry

Table 11-1: Warning Messages – Indicated Failures (cont.)

WARNING MESSAGE	FAULT CONDITION	POSSIBLE CAUSES
SAMPLE TEMP WARN	Sample temperature is < 10°C or > 100°C.	Ambient temperature outside of specified range Failed bench heater Failed bench temperature sensor Relay controlling the bench heater Failed relay board I ² C buss
SOURCE WARNING	Occurs when CO ₂ Ref is <1250 mVDC or >4950 mVDC. Either of these conditions will result in an invalid M/R ratio.	GFC wheel stopped Failed sync/demod board If status LED's on the sync/demod board <u>ARE</u> flashing the cause is most likely a failed: IR source Relay board I ² C buss IR photo-detector
SYSTEM RESET	The computer has rebooted.	This message occurs at power on. If you have not cycled the power on your instrument: <ul style="list-style-type: none"> o Failed +5 VDC power, o Fatal error caused software to restart o Loose connector/wiring
WHEEL TEMP WARNING	The filter wheel temperature is controlled at 68 ± 2 C	Blocked cooling vents below GFC Assembly. Make sure that adequate clear space beneath the analyzer. Analyzer's top cover removed Wheel heater Wheel temperature sensor Relay controlling the wheel heater Entire relay board I ² C buss

11.1.2. Fault Diagnosis with TEST Functions

Besides being useful as predictive diagnostic tools, the test functions viewable from the front panel can be used to isolate and identify many operational problems when combined with a thorough understanding of the analyzer's theory of operation (see Chapter 10).

The acceptable ranges for these test functions are listed in the "Nominal Range" column of the analyzer *Final Test and Validation Data Sheet* (p/n 04307) shipped with the instrument. Values outside these acceptable ranges indicate a failure of one or more of the analyzer's subsystems. Functions whose values are still within the acceptable range but have significantly changed from the measurement recorded on the factory data sheet may also indicate a failure. A worksheet has been provided in Appendix C to assist in recording the value of these test functions.

Table 11-2 contains some of the more common causes for these values to be out of range.

Table 11-2: Test Functions - Indicated Failures

TEST FUNCTIONS	INDICATED FAILURE(S)
TIME	Time of day clock is too fast or slow: To adjust See Section 6.6. Battery in clock chip on CPU board may be dead.
RANGE	Incorrectly configured measurement range(s) could cause response problems with a Data logger or chart recorder attached to one of the analog output. If the Range selected is too small, the recording device will over range. If the Range is too big, the device will show minimal or no apparent change in readings.
STABIL	Indicates noise level of instrument or CO ₂ concentration of sample gas (See Section 11.4.2 for causes).
CO ₂ MEAS & CO ₂ REF	If the value displayed is too high the IR Source has become brighter. Adjust the variable gain potentiometer on the sync/demod board If the value displayed is too low or constantly changing and the CO ₂ REF is OK: <ul style="list-style-type: none"> o Failed multiplexer on the mother board o Failed sync/demod board o Loose connector or wiring on sync/demod board Flow of purge gas to the GFC wheel housing may have stopped If the value displayed is too low or constantly changing and the CO ₂ REF is <u>BAD</u> : <ul style="list-style-type: none"> o GFC wheel stopped or rotation is too slow o Failed sync/demod board IR source o Failed IR source o Failed relay board o Failed I²C buss o Failed IR photo-detector
MR RATIO	When the analyzer is sampling zero air and the ratio is too low: <ul style="list-style-type: none"> o The reference cell of the GFC wheel is contaminated or leaking. o The alignment between the GFC wheel and the segment sensor, the M/R sensor or both is incorrect. o Failed sync/demod board o Flow of purge gas to the GFC wheel housing may have stopped When the analyzer is sampling zero air and the ratio is too high: <ul style="list-style-type: none"> o Zero air is contaminated o Failed IR photo-detector
PRES	See Table 11-1 for SAMPLE PRES WARN
SAMPLE FL	Check for gas flow problems. see Section 11.1.6
SAMPLE TEMP	SAMPLE TEMP should be close to BENCH TEMP . Temperatures outside of the specified range or oscillating temperatures are cause for concern
BENCH TEMP	Bench temp control improves instrument noise, stability and drift. Temperatures outside of the specified range or oscillating temperatures are cause for concern. See Table 11-1 for BENCH TEMP WARNING
WHEEL TEMP	Wheel temp control improves instrument noise, stability and drift. Outside of set point or oscillating temperatures are cause for concern. See Table 11-1 for WHEEL TEMP WARNING
BOX TEMP	If the box temperature is out of range, check fan in the power supply module. Areas to the side and rear of instrument should allow adequate ventilation. See Table 11-1 for BOX TEMP WARNING .
PHT DRIVE	If this drive voltage is out of range it may indicate one of several problems: <ul style="list-style-type: none"> - A poor mechanical connection between the various components in inside the detector housing - An electronic failure of the IR Photo-Detector's built-in cooling circuitry, or; - A temperature problem inside the analyzer chassis. In this case other temperature warnings would also be active such as BENCH TEMP WARNING or BOX TEMP WARNING.
SLOPE	Values outside range indicate <ul style="list-style-type: none"> Contamination of the zero air or span gas supply Instrument is miss-calibrated Blocked gas flow Contaminated or leaking GFC wheel (either chamber) Faulty IR photo-detector Faulty sample faulty IR photo-detector pressure sensor (P1) or circuitry Invalid M/R ratio (see above) Bad/incorrect span gas concentration due.
OFFSET	Values outside range indicate <ul style="list-style-type: none"> Contamination of the zero air supply Contaminated or leaking GFC wheel (either chamber) Faulty IR photo-detector

11.1.3. Using the Diagnostic Signal I/O Function

The Signal I/O parameters found under the DIAG Menu (See Section 6.9.2 and Appendix A) combined with a thorough understanding of the instrument's Theory of Operation (found in Chapter 10) are useful for troubleshooting in three ways:

- The technician can view the raw, unprocessed signal level of the analyzer's critical inputs and outputs.
- All of the components and functions that are normally under algorithmic control of the CPU can be manually exercised.
- The technician can directly control the signal level of the Analog and Digital Output signals.

This allows the technician to systematically observe the effect of directly controlling these signals on the operation of the analyzer. Below in Figure 11-2 is an example of how to use the signal I/O menu to view the raw voltage of an input signal or to control the state of an output voltage or control signal. The specific parameter will vary depending on the situation.

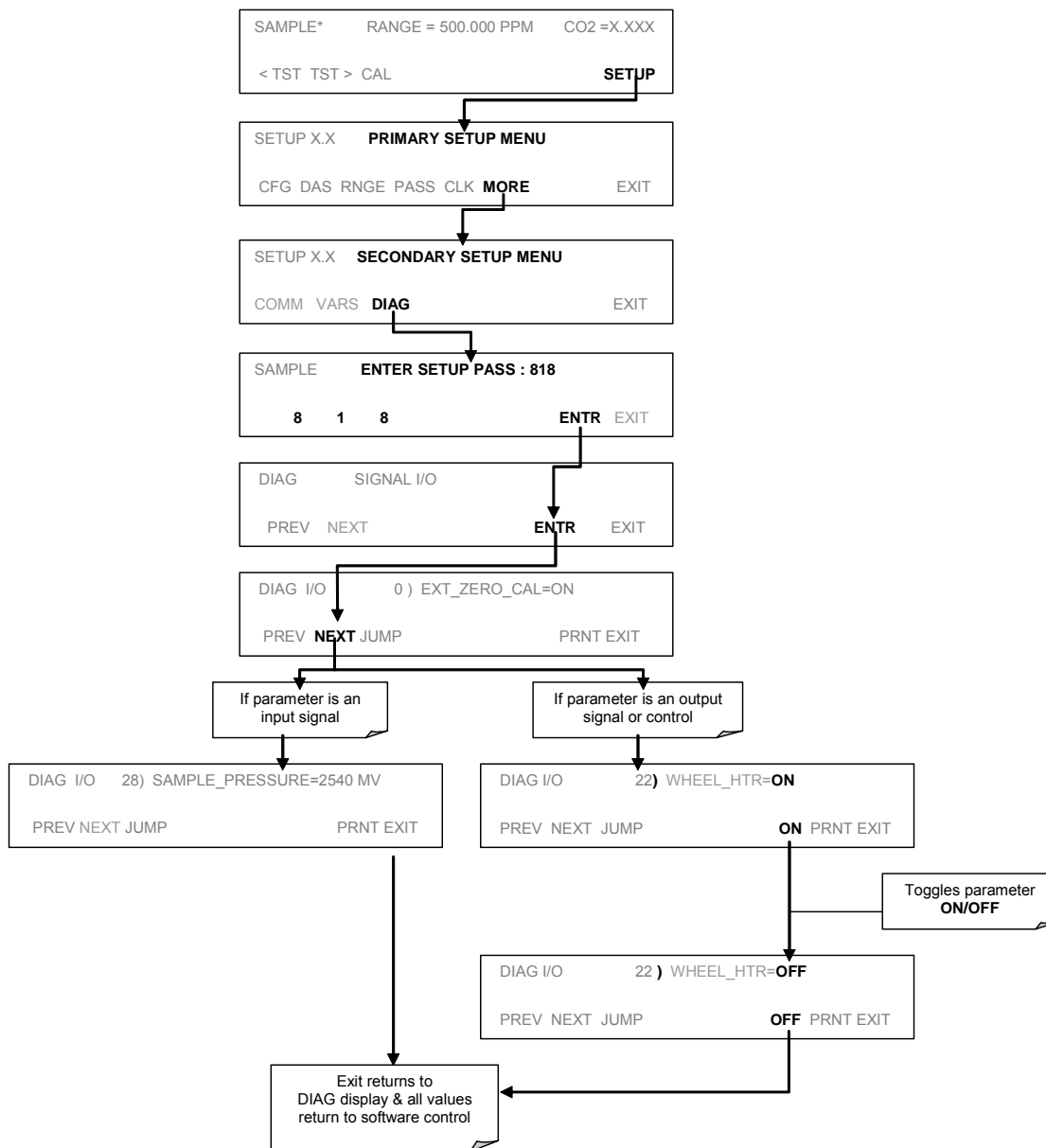

Figure 11-2: Example of Signal I/O Function

11.1.4. Internal Electronic Status LED's

Several LED's are located inside the instrument to assist in determining if the analyzer's CPU, I²C buss and relay board, GFC wheel and the sync/demodulator board are functioning properly.

11.1.4.1. CPU Status Indicator

DS5, a red LED, that is located on upper portion of the motherboard, just to the right of the CPU board, flashes when the CPU is running the main program loop. After power-up, approximately 30 to 60 seconds, DS5 should flash on and off. If characters are written to the front panel display but DS5 does not flash then the program files have become corrupted. If after 30 – 60 seconds neither the DS5 is flashing or no characters have been written to the front panel display then the CPU is bad and must be replaced.

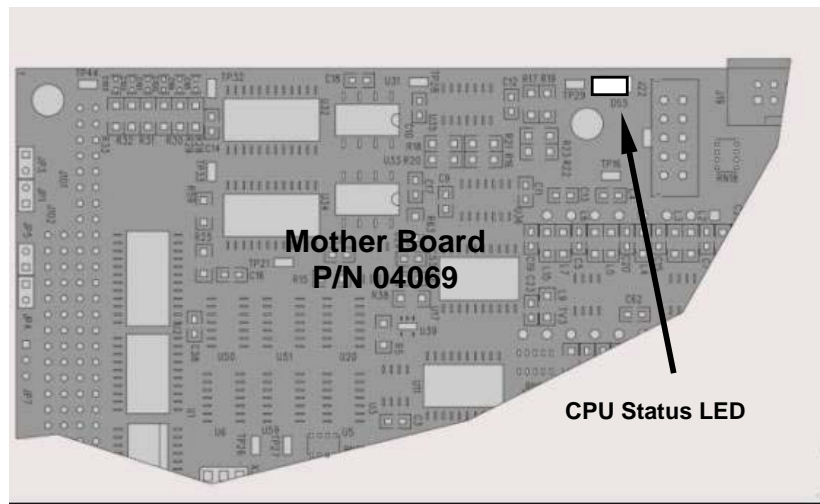

Figure 11-3: CPU Status Indicator

11.1.4.2. Sync Demodulator Status LED's

Two LED's located on the Sync/Demod Board and are there to make it obvious that the GFC Wheel is spinning and the synchronization signals are present:

Table 11-3: Sync/Demod Board Status Failure Indications

LED	FUNCTION	FAULT STATUS	INDICATED FAILURE(S)
D1	M/R Sensor Status (Flashes slowly)	LED is stuck ON or OFF	GFC Wheel is not turning M/R Sensor on Opto-Pickup Board failed Sync/Demod Board failed JP 4 Connector/Wiring faulty Failed/Faulty +5 VDC Power Supply (PS1)
D2	Segment Sensor Status (Flashes quickly)	LED is stuck ON or OFF	GFC Wheel is not turning Segment Sensor on Opto-Pickup Board failed Sync/Demod Board failed JP 4 Connector/Wiring faulty Failed/Faulty +5 VDC Power Supply (PS1)

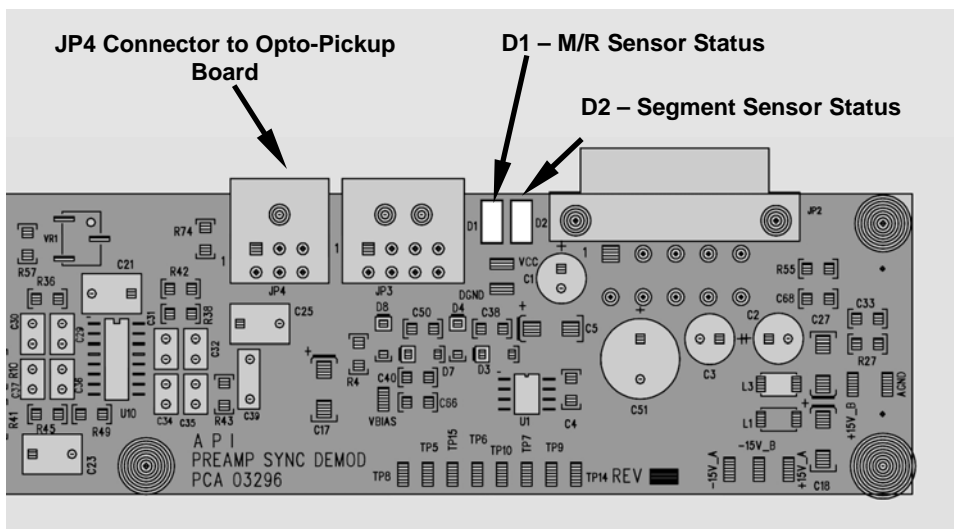

Figure 11-4: Sync/Demod Board Status LED Locations

11.1.4.3. Relay Board Status LED's

There are eight LED's located on the Relay Board. The most important of which is D1, which indicates the health of the I²C buss. If D1 is blinking the other faults following LED's can be used in conjunction with **DIAG** menu signal I/O to identify hardware failures of the relays and switches on the relay (See Section 6.9.2 and Appendix D).

Table 11-4: I²C Status LED Failure Indications

LED	FUNCTION	FAULT STATUS	INDICATED FAILURE(S)
D1 (Red)	I2C buss Health (Watchdog Circuit)	Continuously ON or Continuously OFF	Failed/Halted CPU Faulty Mother Board, Keyboard or Relay Board Faulty Connectors/Wiring between Mother Board, Keyboard or Relay Board Failed/Faulty +5 VDC Power Supply (PS1)

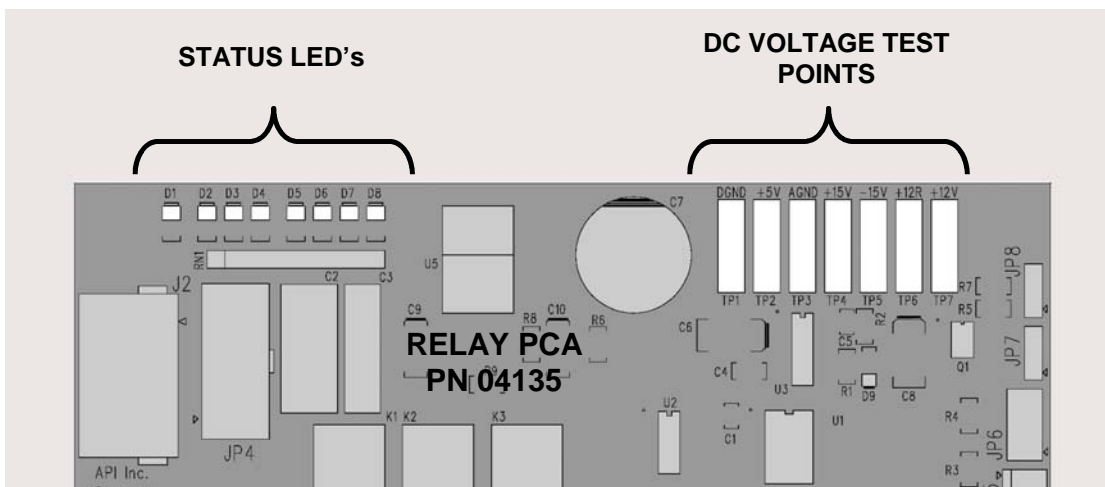

Figure 11-5: Relay Board Status LEDs

Table 11-5: Relay Board Status LED Failure Indications

LED	FUNCTION	SIGNAL I/O PARAMETER		DIAGNOSTIC TECHNIQUE
		ACTIVATED BY	VIEW RESULT	
D2 Yellow	WHEEL HEATER	WHEEL_HEATER	WHEEL_TEMP	Voltage displayed should change. If not: Failed Heater Faulty Temperature Sensor Failed AC Relay Faulty Connectors/Wiring
D3 Yellow	BENCH HEATER	BENCH_HEATER	BENCH_TEMP	Voltage displayed should change. If not: Failed Heater Faulty Temperature Sensor Failed AC Relay Faulty Connectors/Wiring
D4 Yellow	SPARE	N/A	N/A	N/A
D5 Green	SAMPLE/CAL GAS VALVE OPTION	CAL_VALVE	N/A	Sample/Cal Valve should audibly change states. If not: Failed Valve Failed Relay Drive IC on Relay Board Failed Relay Board Faulty +12 VDC Supply (PS2) Faulty Connectors/Wiring
D6 Green	ZERO/SPAN GAS VALVE OPTION	SPAN_VALVE	N/A	Zero/Span Valve should audibly change states. If not: Failed Valve Failed Relay Drive IC on Relay Board Failed Relay Board Faulty +12 VDC Supply (PS2) Faulty Connectors/Wiring
D7 Green	SHUTOFF VALVE OPTION	SHUTOFF_VALVE	N/A	Shutoff Valve should audibly change states. If not: Failed Valve Failed Relay Drive IC on Relay Board Failed Relay Board Faulty +12 VDC Supply (PS2) Faulty Connectors/Wiring
D8 Green	IR SOURCE	IR_SOURCE	CO ₂ _MEASURE	Voltage displayed should change. If not: Failed IR Source Faulty +12 VDC Supply (PS2) Failed Relay Board Failed IR Photo-Detector Failed Sync/Demod Board Faulty Connectors/Wiring

11.2. Gas Flow Problems

The M360E has two main gas flow paths, the sample gas flow path and the GFC purge gas flow path. Both are controlled by a critical flow orifice. Only the sample gas path is measured and reported. When the IZS or zero/span valve options are installed, there are several subsidiary paths but none of those are displayed on the front panel or stored by the iDAS.

With the O₂ sensor option installed, third gas flow controlled with a critical flow orifice is added, but this flow is not measured or reported.

In general, flow problems can be divided into three categories:

- Flow is too high
- Flow is greater than zero, but is too low, and/or unstable
- Flow is zero (no flow)

When troubleshooting flow problems, it is crucial to confirm the actual flow rate without relying on the analyzer's flow display. The use of an independent, external flow meter to perform a flow check as described in Section 9.3.4 is essential. If this test shows the flow to be correct, check the pressure sensors as described in Section 11.5.6.5.

The flow diagrams found in a variety of locations within this manual depicting the M360E in its standard configuration and with options installed can help in troubleshooting flow problems. For your convenience they are collected here.

11.2.1. M360E Internal Gas Flow Diagrams

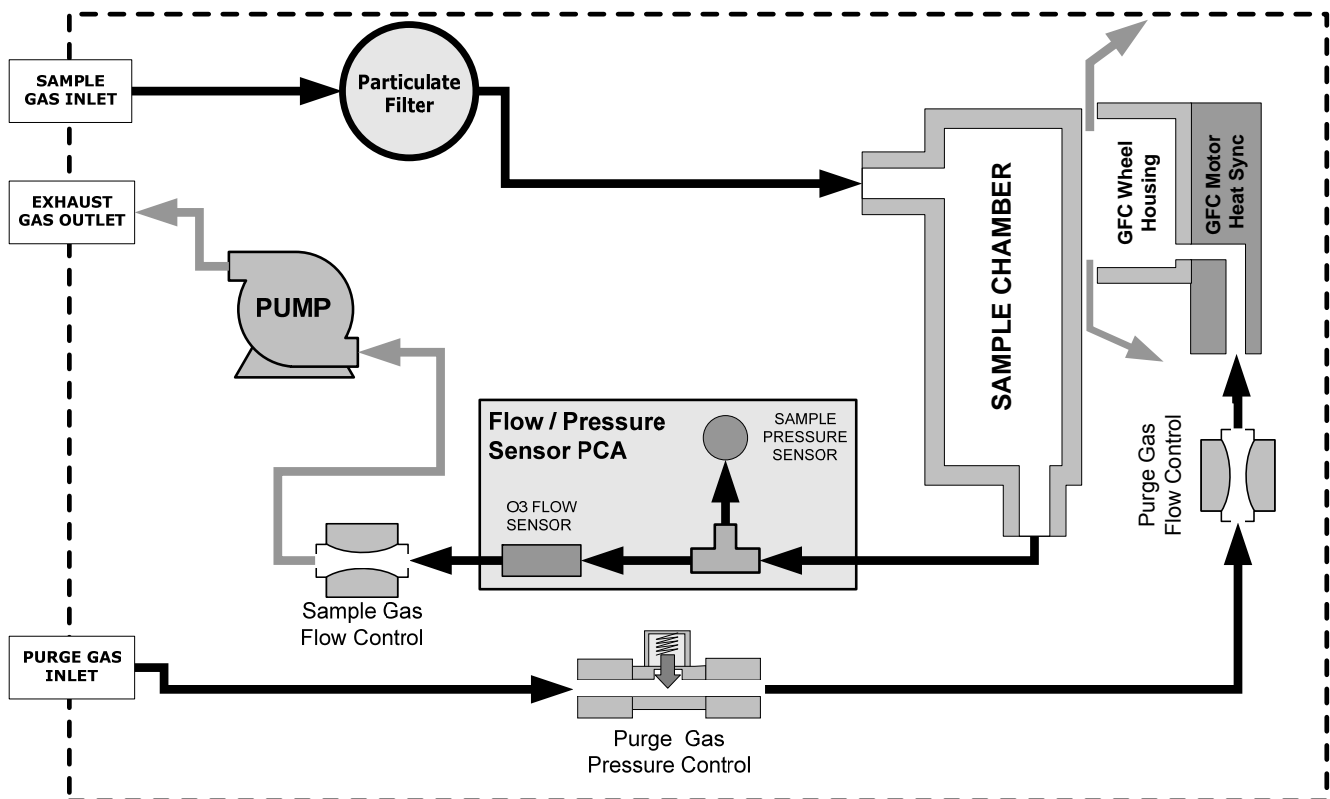

Figure 11-7: M360E – Basic Internal Gas Flow

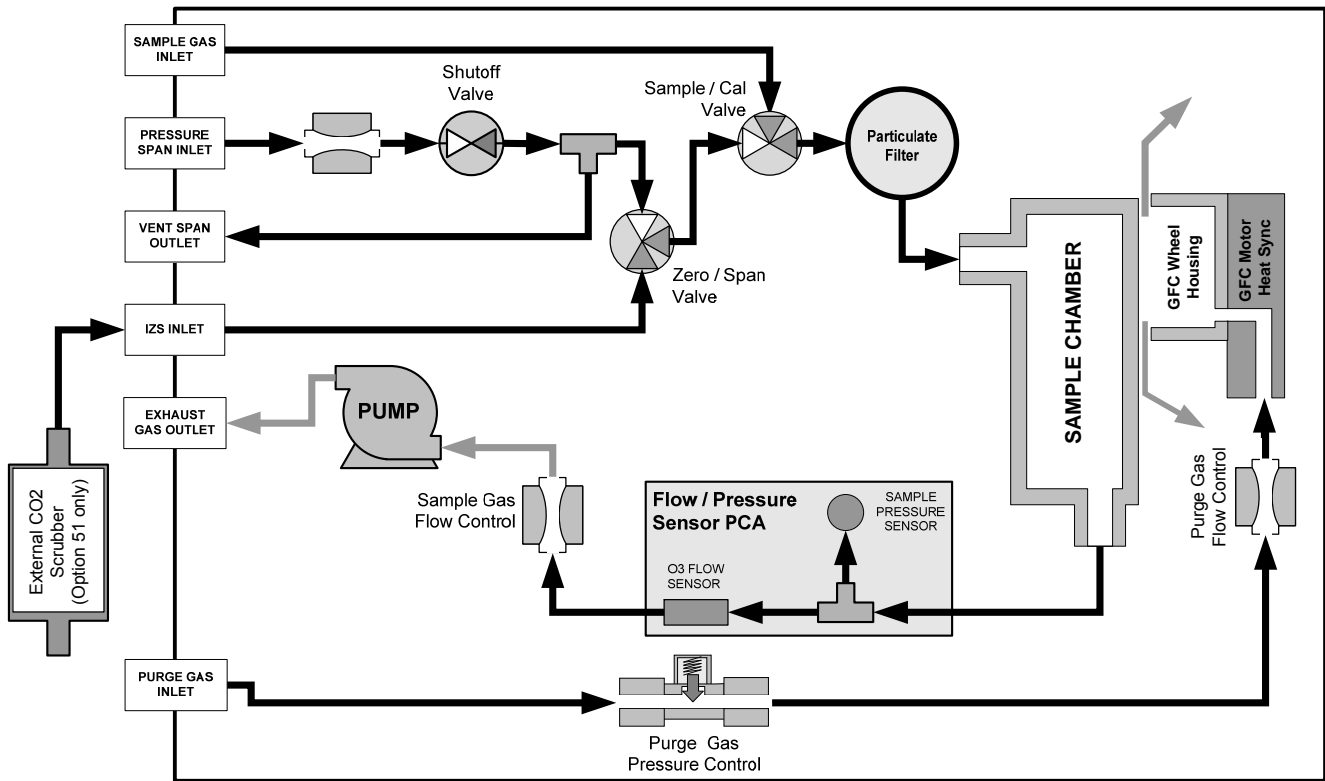

Figure 11-6: Internal Pneumatic Flow OPT 50– Zero/Span/Shutoff Valves

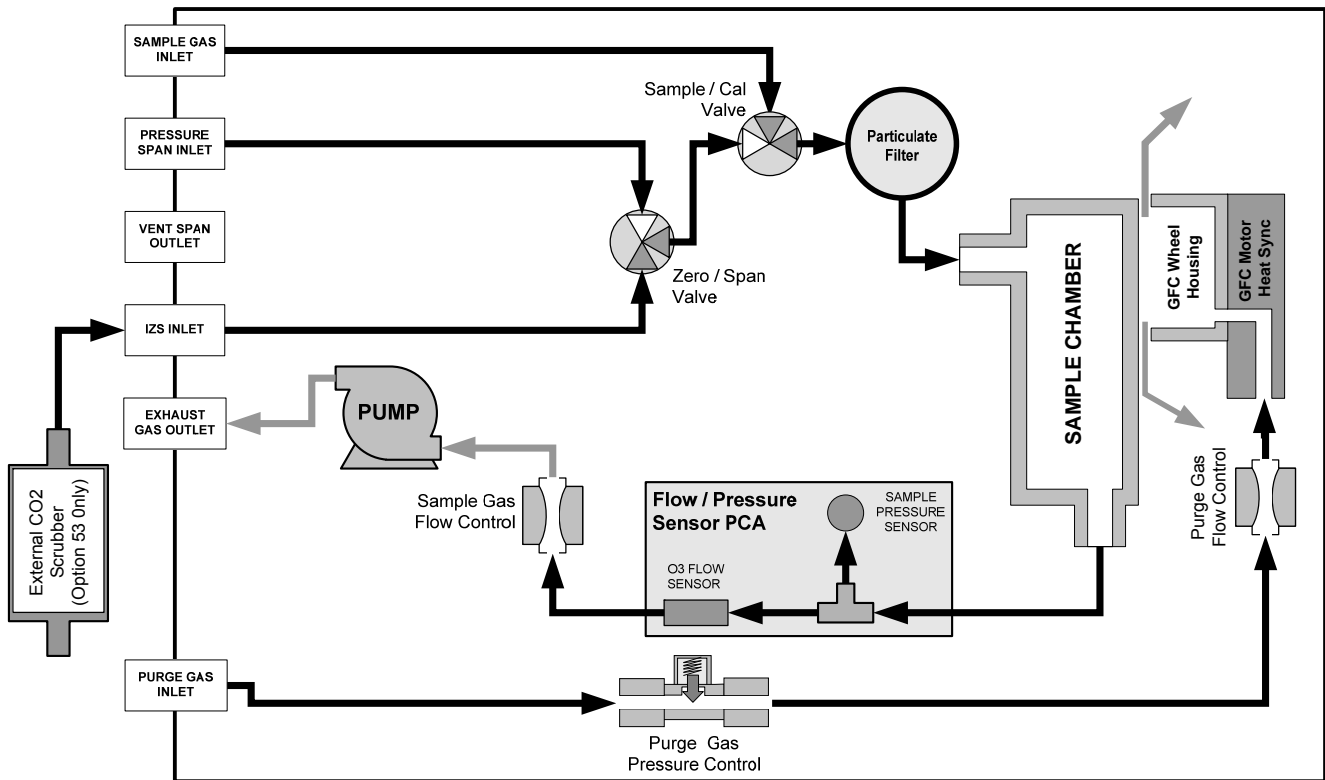

Figure 11-8: Internal Pneumatic Flow – Zero/Span OPT 52 & 53

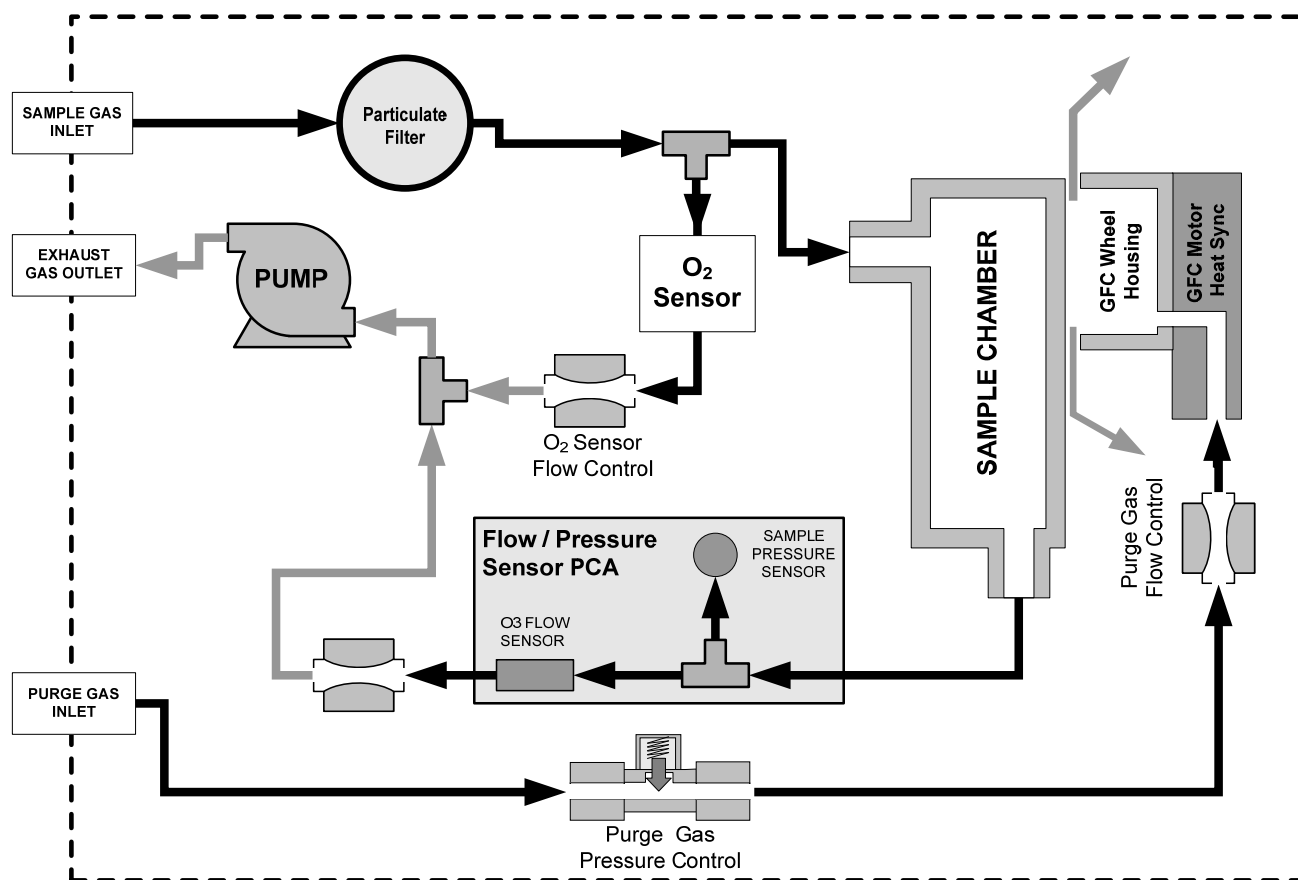

Figure 11.9: M360E – Internal Pneumatics with O₂ Sensor Option 65

11.2.2. Typical Sample Gas Flow Problems

11.2.2.1. Flow is Zero

The unit displays a **SAMPLE FLOW** warning message on the front panel display or the **SAMPLE FLOW** test function reports a zero or very low flow rate.

Confirm that the sample pump is operating (turning). If not, use an AC voltmeter to make sure that power is being supplied to the pump. If no power is present at the electrical leads of the pump.

1. If AC power is being supplied to the pump, but it is not turning, replace the pump.
2. If the pump is operating but the unit reports no gas flow, perform a flow check as described in Section 9.3.4.
3. If no independent flow meter is available:
 - Disconnect the gas lines from both the sample inlet and the exhaust outlet on the rear panel of the instrument.
 - Make sure that the unit is in basic SAMPLE Mode.
 - Place a finger over an Exhaust outlet on the rear panel of the instrument.
 - If gas is flowing through the analyzer, you will feel pulses of air being expelled from the Exhaust outlet.

4. If gas flows through the instrument when it is disconnected from its sources of zero air, span gas or sample gas, the flow problem is most likely not internal to the analyzer. Check to make sure that:
 - All calibrators/generators are turned on and working correctly.
 - Gas bottles are not empty or low.
 - Valves, regulators and gas lines are not clogged or dirty.

11.2.2.2. Low Flow

1. Check if the pump diaphragm is in good condition. If not, rebuild the pump (See Section 9.3.2). Check the Spare Parts List for information of pump rebuild kits.
2. Check for leaks as described in Section 9.3.3. Repair the leaking fitting, line or valve and re-check.
3. Check for the sample filter and the orifice filter for dirt. Replace filters (See Sections 9.3.1 and 11.5.1 respectively).
4. Check for partially plugged pneumatic lines, orifices, or valves. Clean or replace them.
5. If an IZS option is installed in the instrument, press **CALZ** and **CALS**. If the flow increases then suspect a bad sample/cal valve.

11.2.2.3. High Flow

The most common cause of high flow is a leak in the sample flow control assembly or between there and the pump. If no leaks or loose connections are found in the fittings or the gas line between the orifice and the pump, rebuild/clean the sample flow control assembly as described in Section 11.6.1.

11.2.2.4. Displayed Flow = “XXXX”

This warning means that there is inadequate gas flow. There are four conditions that might cause this:

1. A leak upstream or downstream of the flow sensor
2. A flow obstruction upstream or downstream of the flow sensor
3. Bad Flow Sensor Board
4. Bad pump

To determine which case it is, view the sample pressure and sample flow functions on the front panel. If the sample pressure is reading abnormally low, then the cause is likely a flow obstruction upstream of the flow sensor. First, check the sample filter and make sure it is not plugged and then systematically check all the other components upstream of the orifice to ensure that they are not obstructed.

If the sample pressure is reading normal but the sample flow is reading low then it is likely that the pump diaphragm is worn or there is an obstruction downstream of the flow sensor.

11.2.2.5. Actual Flow Does Not Match Displayed Flow

If the actual flow measured does not match the displayed flow, but is within the limits of 720-880 cc/min, adjust the calibration of the flow measurement as described in Section 6.9.8.

11.2.2.6. Sample Pump

The sample pump should start immediately after the front panel power switch is turned ON. With the Sample Inlet plugged, the test function **PRES** should read about 10⁻³-Hg for a pump in good condition. Readings above 10⁻³ Hg indicate that the pump needs rebuilding. If the test function **SAMP FL** is greater than 10 cm³/min there is a leak in the pneumatic lines.

11.2.3. Poor or Stopped Flow of Purge Gas

If sufficient purge gas is not supplied to the GFC wheel housing, cyclical fluctuations in readings at zero or low CO₂ concentrations, such as < 100 ppm, may occur. These fluctuations are the result of changes in the CO₂ concentration of the ambient atmosphere throughout the course of the day and night. In isolated areas with relatively few people working nearby the ambient CO₂ concentration will fall during the day and rise during the night as rate of photosynthesis of the plants in the surrounding area decreases and increases. In a lab environment with a relatively high human occupancy the ambient CO₂ concentration will increase during those parts of the day when the highest number of workers are present. If the GFC wheel housing is allowed to fill with ambient air, these natural, diurnal fluctuations might be detected by the instrument and cause it's in its calculation of the CO₂ concentration of the sample gas to drift.

Another possible symptom of poor or stopped purge gas flow would be the inability to measure zero concentrations accurately at the end of a work day on a system that was calibrated at the beginning of a workday. Although this could also be due to local fluctuations in ambient CO₂ concentration during the day.

11.3. Calibration Problems

11.3.1. Miscalibrated

There are several symptoms that can be caused by the analyzer being miss-calibrated. This condition is indicated by out of range Slopes and Offsets as displayed through the test functions and is frequently caused by the following:

1. **BAD SPAN GAS.** This can cause a large error in the slope and a small error in the offset. Delivered from the factory, the M360E's slope is within $\pm 15\%$ of nominal. Bad span gas will cause the analyzer to be calibrated to the wrong value. If in doubt have the span gas checked by an independent lab.
2. **CONTAMINATED ZERO GAS.** Excess H₂O can cause a positive or negative offset and will indirectly affect the slope.
3. **Dilution calibrator not set up correctly or is malfunctioning.** This will also cause the slope, but not the zero, to be incorrect. Again the analyzer is being calibrated to the wrong value.
4. **Too many analyzers on the manifold.** This can cause either a slope or offset error because ambient gas with its pollutants will dilute the zero or span gas.

11.3.2. Non-Repeatable Zero and Span

As stated earlier, leaks both in the M360E and in the external system are a common source of unstable and non-repeatable readings.

5. Check for leaks in the pneumatic systems as described in Section 9.3.3. Don't forget to consider pneumatic components in the gas delivery system outside the M360E. Such as:
 - A change in zero air source such as ambient air leaking into zero air line, or;
 - A change in the span gas concentration due to zero air or ambient air leaking into the span gas line.
6. Once the instrument passes a leak check, do a flow check (See Section 9.3.4) to make sure adequate sample is being delivered to the sensor assembly.
7. A failing IR photo-detector may be at fault. Check the **CO2 MEAS** and **CO2 REF** test functions via the front panel display to make sure the signal levels are in the normal range (See Appendix A) and are quiet.
8. Confirm the sample pressure, wheel temperature, bench temperature, and sample flow readings are correct and have steady readings.
9. Disconnect the exhaust line from the optical bench near the rear of the instrument and plug this line into the **SAMPLE** inlet creating a pneumatic loop. The CO₂ concentration (either zero or span) now must be constant. If readings become quiet, the problem is in the external pneumatics supplies for sample gas, span gas or zero air.
10. If pressurized span gas is being used with a zero/span valve option, make sure that the venting is adequate (See Section 3.1.2 and 5.4)
11. If it is the zero point that is non-repeatable, and if that non-repeatability seems to only occur at a certain time of day, such as when worker occupancy is highest or lowest, make sure the flow of purge gas to the GFC wheel housing has not stopped (See Sections 10.2.2 and 11.1.7 for more information).

11.3.3. Inability to Span – No SPAN Key

1. Confirm that the carbon dioxide span gas source is accurate; this can be done by switching between two span-gas tanks. If the CO₂ concentration is different, there is a problem with one of the tanks.
2. Check for leaks in the pneumatic systems as described in Section 9.3.3.
3. Make sure that the expected span gas concentration entered into the instrument during calibration is the correct span gas concentration and not too different from expected span value. This can be viewed via the **RNG** Menu (See Section 6.7).
4. Check to make sure that there is no ambient air or zero air leaking into span gas line.

11.3.4. Inability to Zero – No ZERO Key

1. Confirm that there is a good source of zero air. Dilute a tank of span gas with the same amount of zero air from two different sources. If the CO₂ Concentration of the two measurements is different, there is a problem with one of the sources of zero air.
2. Check for leaks in the pneumatic systems as described in Section 9.3.3.
3. If the analyzer has had zero/span valve options 52 or 53, the CO₂ scrubber may need maintenance.
4. Check to make sure that there is no ambient air leaking into zero air line.

11.4. Other Performance Problems

Dynamic problems (i.e. problems which only manifest themselves when the analyzer is monitoring sample gas) can be the most difficult and time consuming to isolate and resolve. The following provides an itemized list of the most common dynamic problems with recommended troubleshooting checks and corrective actions.

11.4.1. Temperature Problems

Individual control loops are used to maintain the set point of the absorption bench, filter wheel, and IR photo-detector temperatures. If any of these temperatures are out of range or are poorly controlled, the M360E will perform poorly.

11.4.1.1. Box or Sample Temperature

Box Temperature

The box temperature sensor is mounted to the motherboard and cannot be disconnected to check its resistance. Rather check the **BOX TEMP** signal using the **SIGNAL I/O** function under the **DIAG** Menu (See Section 11.1.3). This parameter will vary with ambient temperature, but at ~30°C (6-7° above room temperature) the signal should be ~1450 mV.

Sample Temperature

The Sample Temperature should closely track the bench temperature. If it does not, locate the sensor, which is located at the midpoint of the optical bench in a brass fitting. Unplug the connector labeled "Sample", and measure the resistance of the thermistor; at room temperature (25°C) it should be ~30K Ohms, at operating temperature, 48°C, it should be ~ 12K Ohms

11.4.1.2. Bench Temperature

There are three possible failures that could cause the Bench temperature to be incorrect.

1. The heater mounted to the bottom of the Absorption bench is electrically shorted or open. Check the resistance of the two heater elements by measuring between pin 2 and 4 (~76 Ohms), and pin 3 and 4 (~330 Ohms), of the white five-pin connector just below the sample temperature sensor on the Bench (pin 1 is the pointed end).
2. Assuming that the I²C buss is working and that there is no other failure with the relay board, the solid-state relay (K2) on the relay board may have failed. Using the **BENCH_HEATER** parameter under the signal I/O function, as described above, turn on and off K2 (D3 on the relay board should illuminate as the heater is turned on). Check the AC voltage present between pin 2 and 4, for a 100 or 115 VAC model, and pins 3 and 4, for a 220-240 VAC model.

**WARNING:****HAZARDOUS VOLTAGES ARE PRESENT DURING THIS TEST**

3. If the relay has failed there should be no change in the voltage across pins 2 and 4 or 3 and 4. NOTE: K2 is in a socket for easy replacement.

4. If K2 checks out OK, the thermistor temperature sensor located on the optical bench near the front of the instrument could be at fault. Unplug the connector labeled "Bench", and measure the resistance of the thermistor. At room temperature it should have approximately 30K Ohms resistance near the 48°C set point it should have ~12K ohms.

11.4.1.3. GFC Wheel Temperature

Like the bench heater above there are three possible causes for the GFC wheel temperature to have failed.

1. The wheel heater has failed. Check the resistance between pins 1 and 4 on the white five-pin connector just below the sample temperature sensor on the bench (pin 1 is the pointed end). It should be approximately 275 ohms.
2. Assuming that the I²C buss is working and that there is no other failure with the relay board, the solid-state relay (K1) on the relay board may have failed. Using the **WHEEL_HEATER** parameter under the signal I/O function, as described above, turn on and off K1 (D2 on the relay board should illuminate as the heater is turned on). Check the AC voltage present between pin 1 and 4.



WARNING:

HAZARDOUS VOLTAGES ARE PRESENT DURING THIS TEST

3. If the relay has failed there should be no change in the voltage across pins 1 and 4. NOTE: K1 is socketed for easy replacement.
4. If K1 checks out OK, the thermistor temperature sensor located at the front of the filter wheel assembly may have failed. Unplug the connector labeled "Wheel", and measure the resistance of the thermistor. The resistance near the 68°C set point is ~5.7k ohms.

11.4.1.4. IR Photo-Detector TEC Temperature

If the **PHT DRIVE** test parameter described above in Table 11-2 is out of range there are two four possible causes of failure.

1. The screws retaining the IR photo detector to the absorption bench have become loose. Carefully tighten the screws, hand-tight and note whether, after the analyzer has come up to operating temperature, whether the **PHT DRIVE** voltage has returned to an acceptable level.
2. The two large transistor-type devices mounted to the side of the Absorption Bench have come loose from the bench. Tighten the retaining screws and note whether there is an improvement in the **PHT DRIVE** voltage.
3. The photo-detector has failed. Contact the factory for instructions.
4. The sync demodulator circuit board has failed. Contact the factor for instructions.

11.4.2. Excessive Noise

Noise is continuously monitored in the TEST functions as the **STABIL** reading and only becomes meaningful after sampling a constant gas concentration for at least 10 minutes. Compare the current **STABIL** reading with that recorded at the time of manufacture (included in the M360E *Final Test and Validation Data Sheet*-p/n 04271 shipped with the unit from Teledyne Instruments).

1. The most common cause of excessive noise is leaks. Leak check and flow check the instrument described in Section 9.3.
2. Detector failure – caused by failure of the hermetic seal or over-temperature due to poor heat sinking of the detector can to the optical bench. In addition to increased noise due to poor signal-to-noise ratio, another indicator of detector failure is a drop in the signal levels of the **CO₂ MEASURE** signal and **CO₂ REFERENCE** signal.
3. Sync/Demod Board failure. There are many delicate, high impedance parts on this board. Check the **CO₂ MEAS** and **CO₂ REF** Test Functions via the Front Panel Display.
4. The detector cooler control circuit can fail for reasons similar to the detector itself failing. Symptoms would be a change in **MR RATIO** Test Function when zero air is being sampled.

Also check the SIGNAL I/O parameter **PHT DRIVE**. After warm-up, and at 25°C ambient, if PHT DRIVE < 4800 mV, the cooler is working properly. If PHT DRIVE is > 4800 mV there is a malfunction.

5. The +5 and ±15 VDC voltages in the M360E are provided by switching power supplies. Switch mode supplies create DC outputs by switching the input AC waveform at high frequencies. As the components in the switcher age and degrade, the main problem observed is increased noise on the DC outputs. If a noisy switcher power supply is suspected, attach an oscilloscope to the DC output test points located on the top right hand edge of the Relay board. Look for short period spikes > 100 mV p-p on the DC output.

11.5. Subsystem Checkout

The preceding s of this manual discussed a variety of methods for identifying possible sources of failures or performance problems within the analyzer. In most cases this included a list of possible causes. This describes how to determine individually determine if a certain component or subsystem is actually the cause of the problem being investigated.

11.5.1. AC Mains Configuration

The analyzer is correctly configured for the AC mains voltage in use if:

1. The Sample Pump is running.
2. The GFC wheel motor is spinning. LED's D1 & D2 (located on the synch/demod PCA) should be flashing.
3. If incorrect power is suspected, check that the correct voltage and frequency is present at the line input on the rear panel.
 - If the unit is set for 230 VAC and is plugged into 115VAC, or 100VAC the sample pump will not start, and the heaters will not come up to temperature.
 - If the unit is set for 115 or 100 VAC and is plugged into a 230 VAC circuit, the circuit breaker built into the ON/OFF Switch on the Front Panel will trip to the OFF position immediately after power is switched on.

11.5.2. DC Power Supply

If you have determined that the analyzer's AC mains power is working, but the unit is still not operating properly, there may be a problem with one of the instrument's switching power supplies. The supplies can have two faults, namely no DC output, and noisy output.

To assist tracing DC Power Supply problems, the wiring used to connect the various printed circuit assemblies and DC Powered components and the associated test points on the relay board follow a standard color-coding scheme as defined in the following table.

Table 11-6: DC Power Test Point and Wiring Color Codes

NAME	TEST POINT#	TP AND WIRE COLOR
Dgnd	1	Black
+5V	2	Red
Agnd	3	Green
+15V	4	Blue
-15V	5	Yellow
+12V	6	Purple
+12R	7	Orange

A voltmeter should be used to verify that the DC voltages are correct per the values in the table below, and an oscilloscope, in AC mode, with band limiting turned on, can be used to evaluate if the supplies are producing excessive noise (> 100 mV p-p).

Table 11-7: DC Power Supply Acceptable Levels

POWER SUPPLY ASSY	VOLTAGE	CHECK RELAY BOARD TEST POINTS				MIN V	MAX V
		FROM TEST POINT		TO TEST POINT			
		NAME	#	NAME	#		
PS1	+5	Dgnd	1	+5	2	4.8	5.25
PS1	+15	Agnd	3	+15	4	13.5	16V
PS1	-15	Agnd	3	-15V	5	-14V	-16V
PS1	Agnd	Agnd	3	Dgnd	1	-0.05	0.05
PS1	Chassis	Dgnd	1	Chassis	N/A	-0.05	0.05
PS2	+12	+12V Ret	6	+12V	7	11.75	12.5
PS2	Dgnd	+12V Ret	6	Dgnd	1	-0.05	0.05

11.5.3. I²C Bus

Operation of the I²C buss can be verified by observing the behavior of D1 on the Relay Board in conjunction with the performance of the front panel display. Assuming that the DC power supplies are operating properly and the wiring from the motherboard to the Keyboard, and the wiring from the keyboard to the Relay board, is intact, the I²C buss is operating properly if:

- D1 on the relay board is flashing, or;
- D1 is not flashing but pressing a key on the front panel results in a change to the display.

11.5.4. Keyboard/Display Interface

The front panel keyboard, display and Keyboard Display Interface PCA (03975 or 04258) can be verified by observing the operation of the display when power is applied to the instrument and when a key is pressed on the front panel. Assuming that there are no wiring problems and that the DC power supplies are operating properly:

1. The vacuum fluorescent display is good if on power-up a “-” character is visible on the upper left hand corner of the display.
2. The CPU Status LED, DS5, is flashing, See Section 11.1.4.1.
3. If there is a “-” character on the display at power-up and D1 on the relay board is flashing then the keyboard/display interface PCA is bad.
4. If the analyzer starts operation with a normal display but pressing a key on the front panel does not change the display, then there are three possible problems:
 - One or more of the keys is bad,
 - The interrupt signal between the Keyboard Display interface and the motherboard is broken, or
 - The Keyboard Display Interface PCA is bad.

11.5.5. Relay Board

The relay board PCA (04135) can be most easily checked by observing the condition of the its status LEDs on the relay board, as described in Section 11.1.4.3, and the associated output when toggled on and off through signal I/O function in the diagnostic menu, See Section 11.1.3.

1. If the front panel display responds to key presses and D1 on the relay board is NOT flashing then either the wiring between the Keyboard and the relay board is bad, or the relay board is bad.
2. If D1 on the relay board is flashing and the status indicator for the output in question (heater power, valve drive, etc.) toggles properly using the signal I/O function, then the associated control device on the relay board is bad. Several of the control devices are in sockets and can be easily replaced. The table below lists the control device associated with a particular function:

Table 11-8: Relay Board Control Devices

FUNCTION	CONTROL DEVICE	IN SOCKET
Wheel Heater	K1	Yes
Bench Heater	K2	Yes
Spare AC Control	K3	Yes
IZS Valves	U4	Yes
IR Source Drive	U5	No

The IR source drive output can be verified by measuring the voltage at J16 with the IR source disconnected. It should be 11.5 ± 0.5 VDC.

11.5.6. Sensor Assembly

11.5.6.1. Sync/Demodulator Assembly

To verify that the Sync/Demodulator Assembly is working follow the procedure below:

1. Verify that D1 and D2 are flashing (they flash at different rates, see Table 11-3).
 - If not check the opto pickup assembly, Section 11.5.6.2 and the GFC wheel drive, Section 11.5.6.3.
 - If the wheel drive and opto pickup are working properly then verify that there is 2.4 ± 0.1 VAC and 2.5 ± 0.15 VDC between digital ground and TP 5 on the sync demod board. If not then check the wiring between the sync/demod and opto pickup assembly (see interconnect drawing 04216). If good then the sync/demod board is bad.
2. Verify that the IR source is operating, Section 11.5.6.4.
3. With the analyzer connected to zero air, measure between TP11 (measure) and analog ground, and TP12 (reference) and analog ground.
 - If they are similar to values recorded on the factory data sheet then there is likely a problem with the wiring or the A/D converter.
 - If they are not then either the sync demodulator board or the IR-photodetector are bad. See Section 11.4.1.4 for problems with the IR-photodetector TEC drive.

11.5.6.2. Opto Pickup Assembly

Operation of the opto pickup PCA (04088) can be verified with a voltmeter. Measure the AC and DC voltage between digital ground on the relay board, or keyboard and TP1 and TP2 on the sync pickup PCA. For a working board, with the GFC motor spinning, they should read 2.4 ± 0.1 VAC and 2.5 ± 0.15 VDC.

Further confirmation that the pickups and motor are operating properly can be obtained by measuring the frequency at TP1 and TP2 using a frequency counter, a digital volt meter with a frequency counter, or an oscilloscope per the table below.

Table 11-9: Opto Pickup Board Nominal Output Frequencies

AC MAINS FREQ.	NOMINAL MEASURED FREQUENCY	
	TP1	TP2
50 Hz	25	300
60 Hz	30	360

11.5.6.3. GFC Wheel Drive

If the D1 and D2 on the sync demodulator board are not flashing then:

1. Check for power to the motor by measuring between pins 1 and 3 on the connector feeding the motor. For instruments configured for 120 or 220-240VAC there should be approximately 88 VAC for instruments configured for 100VAC, it should be the voltage of the AC mains, approximately 100VAC.
2. Verify that the frequency select jumper, JP4, is properly set on the Relay Board. For 50 Hz operation it should be installed. For 60 Hz operation may either be missing or installed in a vertical orientation.
3. If there is power to the motor and the frequency select jumper is properly set then the motor is likely bad. See Section 11.6.2 for instructions on removing and replacing the GFC assembly that the motor is bolted to.

11.5.6.4. IR Source

The IR source can be checked using the following procedure:

1. Disconnect the source and check its resistance when cold. When new, the source should have a cold resistance of more than 1.5 Ohms but less than 3.5 Ohms. If not, then the source is bad.
2. With the source disconnected, energize the analyzer and wait for it to start operating. Measure the drive Voltage between pins 1 and 2 on the jack that the source is normally connected to; it should be 11.5 ± 0.25 VDC. If not, then there is a problem with either the wiring, the Relay Board, or the +12V power supply.
3. If the drive voltage is correct in step 2, then remove the source from the heat sink assembly (2 screws on top) and connect to its mating connector. Observe the light being emitted from the source. It should be centered at the bottom of the U-shaped element. If there is either no emission or a badly centered emission then the source is bad.

11.5.6.5. Pressure/Flow Sensor Assembly

The pressure/flow sensor PCA, located on the top of the absorption bench, can be checked with a Voltmeter using the following procedure which, assumes that the wiring is intact, and that the motherboard and the power supplies are operating properly:

1. For Pressure related problems:
 - Measure the voltage across C1 it should be 5 ± 0.25 VDC. If not then the board is bad.
 - Measure the voltage across TP4 and TP1. With the sample pump disabled it should be 4500 mV ± 250 mV. With the pump energized it should be approximately 200 mV less. If not, then S1, the pressure transducer is bad, the board is bad, or there is a pneumatic failure preventing the pressure transducer from sensing the absorption cell pressure properly.
 - For flow related problems:
 - Measure the voltage across TP2 and TP1 it should be 10 ± 0.25 VDC. If not then the board is bad.
 - Measure the voltage across TP3 and TP1. With proper flow (800 sccm at the sample inlet) this should be approximately 4.5V (this voltage will vary with altitude). With flow stopped (sample inlet blocked) the voltage should be approximately 1V. If the voltage is incorrect, the flow sensor is bad, the board is bad or there is a leak upstream of the sensor.

11.5.7. Motherboard

11.5.7.1. A/D Functions

The simplest method to check the operation of the A-to-D converter on the motherboard is to use the Signal I/O function under the DIAG menu to check the two A/D reference voltages and input signals that can be easily measured with a voltmeter.

1. Use the Signal I/O function (See Section 11.1.3 and Appendix A) to view the value of **REF_4096_MV** and **REF_GND**. If both are within 3 mV of nominal (4096 and 0), and are stable, ± 0.5 mV then the basic A/D is functioning properly. If not then the motherboard is bad.
2. Choose a parameter in the Signal I/O function such as **SAMPLE_PRESSURE**, **SAMPLE_FLOW**, **CO₂_MEASURE** or **CO₂_REFERENCE**. Compare these voltages at their origin (see interconnect drawing 04215 and interconnect list 04216) with the voltage displayed through the signal I/O function. If the wiring is intact but there is a large difference between the measured and displayed voltage (± 10 mV) then the motherboard is bad.

11.5.7.2. Analog Outputs: Voltage

To verify that the analog outputs are working properly, connect a voltmeter to the output in question and perform an analog output step test as described in Section 6.9.3.

For each of the steps, taking into account any offset that may have been programmed into channel (See Section 6.9.4), the output should be within 1% of the nominal value listed in the table below except for the 0% step, which should be within 2 to 3 mV. If one or more of the steps fails to be within this range then it is likely that there has been a failure of the either or both of the DACs and their associated circuitry on the motherboard.

Table 11-10: Analog Output Test Function - Nominal Values Voltage Outputs

		FULL SCALE OUTPUT VOLTAGE			
		100MV	1V	5V	10V
STEP	%	NOMINAL OUTPUT VOLTAGE			
1	0	0	0	0	0
2	20	20 mV	0.2	1	2
3	40	40 mV	0.4	2	4
4	60	60 mV	0.6	3	6
5	80	80 mV	0.8	4	8
6	100	100 mV	1.0	5	10

11.5.7.3. Analog Outputs: Current Loop

To verify that the analog outputs with the optional current mode output are working properly, connect a 250 ohm resistor across the outputs and use a voltmeter to measure the output as described in Section 6.9.4.2 and then perform an analog output step test as described in Section 6.9.3.

For each step the output should be within 1% of the nominal value listed in the table below.

Table 11-11: Analog Output Test Function - Nominal Values Current Outputs

		OUTPUT RANGE			
		2 -20		4 -20	
		NOMINAL OUTPUT VALUES			
STEP	%	CURRENT	V(250 OHMS)	CURRENT	V(250 OHMS)
1	0	2 mA	0.5V	4	1
2	20	5.6	1.4	7.2	1.8
3	40	9.2	2.3	10.4	2.6
4	60	12.8	3.2	13.6	3.4
5	80	16.4	4.1	16.8	4.2
6	100	20	5	20	5

11.5.7.4. Status Outputs

The procedure below can be used to test the Status outputs:

1. Connect a jumper between the “D” pin and the “▽” pin on the status output connector.
2. Connect a 1000 ohm resistor between the “+” pin and the pin for the status output that is being tested.
3. Connect a voltmeter between the “▽” pin and the pin of the output being tested (see table below).

Under the **DIAG→ SIGNAL I/O** menu (See Section 11.1.3), scroll through the inputs and outputs until you get to the output in question. Alternately turn on and off the output noting the voltage on the voltmeter, it should vary between 0 volts for ON and 5 volts for OFF.

Table 11-12: Status Outputs Check

PIN (LEFT TO RIGHT)	STATUS
1	SYSTEM OK
2	CONC VALID
3	HIGH RANGE
4	ZERO CAL
5	SPAN CAL
6	DIAG MODE
7	ALRM1
8	ALRM2

11.5.7.5. Control Inputs – Remote Zero, Span

The control input bits can be tested by the following procedure:

1. Connect a jumper from the +5 pin on the Status connector to the x5V on the Control In connector.
2. Connect a second jumper from the ‘-‘ pin on the Status connector to the A pin on the Control In connector. The instrument should switch from **SAMPLE** mode to **ZERO CAL R** mode.
3. Connect a second jumper from the ‘-‘ pin on the Status connector to the B pin on the Control In connector. The instrument should switch from **SAMPLE** mode to **SPAN CAL R** mode.
4. In each case, the M360E should return to **SAMPLE** mode when the jumper is removed.

11.5.8. CPU

There are two major types of failures associated with the CPU board: complete failure and a failure associated with the Disk-On Chip on the CPU board. If either of these failures occur, contact the factory.

1. For complete failures, assuming that the power supplies are operating properly and the wiring is intact, the CPU is bad if on powering the instrument:
 - The vacuum fluorescent display shows a dash in the upper left hand corner.
 - The CPU Status LED, DS5, is not flashing. (See Section 11.1.4.1.)
 - There is no activity from the primary RS-232 port on the rear panel even if “? <ret>” is pressed.
 - In some rare circumstances this failure may be caused by a bad IC on the motherboard, specifically U57 the large, 44 pin device on the lower right hand side of the board. If this is true, removing U57 from its socket will allow the instrument to startup but the measurements will be incorrect.
2. If the analyzer stops part way through initialization (there are words on the vacuum fluorescent display) then it is likely that the DOC has been corrupted.

11.5.9. RS-232 Communications

11.5.9.1. General RS-232 Troubleshooting

Teledyne Instruments analyzers use the RS-232 communications protocol to allow the instrument to be connected to a variety of computer-based equipment. RS-232 has been used for many years and as equipment has become more advanced, connections between various types of hardware have become increasingly difficult. Generally, every manufacturer observes the signal and timing requirements of the protocol very carefully.

Problems with RS-232 connections usually center around 4 general areas:

1. Incorrect cabling and connectors. See Section 6.11.2 for connector and pin-out information.
2. The BAUD rate and protocol are incorrectly configured. See Section 6.10.7.
3. If a modem is being used, additional configuration and wiring rules must be observed. See Section 6.13.2.6
4. Incorrect setting of the DTE – DCE Switch is set correctly. See Section 6.10.5
5. Verify that cable (03596) that connects the serial COM ports of the CPU to J12 of the motherboard is properly seated

11.5.9.2. Troubleshooting Analyzer/Modem or Terminal Operation

These are the general steps for troubleshooting problems with a modem connected to a Teledyne Instruments analyzer.

1. Check cables for proper connection to the modem, terminal or computer.
2. Check to make sure the DTE-DCE is in the correct position as described in Section 6.10.5.
3. Check to make sure the set up command is correct (See Section 6.13.2.7)
4. Verify that the Ready to Send (RTS) signal is at logic high. The M360E sets pin 7 (RTS) to greater than 3 volts to enable modem transmission.
5. Make sure the BAUD rate, word length, and stop bit settings between modem and analyzer match, See Section 6.10.7.
6. Use the RS-232 test function to send "w" characters to the modem, terminal or computer; See Section 6.10.8.
7. Get your terminal, modem or computer to transmit data to the analyzer (holding down the space bar is one way); the green LED should flicker as the instrument is receiving data.
8. Make sure that the communications software or terminal emulation software is functioning properly.

Further help with serial communications is available in a separate manual "RS-232 Programming Notes" Teledyne Instruments part number 013500000.

11.6. Repair Procedures

This contains procedures that might need to be performed on rare occasions when a major component of the analyzer requires repair or replacement.

11.6.1. Repairing Sample Flow Control Assembly

The critical flow orifice is housed in the flow control assembly (Teledyne Instruments part number: 001760400) located on the top of the optical bench. A sintered filter protects the jewel orifice so it is unusual for the orifice to need replacing, but if it does, or the filter needs replacement please use the following procedure (see the Spare Parts list in Appendix B for part numbers and kits):

1. Turn off power to the analyzer.
2. Locate the assembly attached to the sample pump, see Figure 3–3.
3. Disconnect the pneumatic connection from the flow assembly and the assembly from the pump.
4. Remove the fitting and the components as shown in the exploded view in Figure 11.6.
5. Replace the o-rings (p/n OR000001) and the sintered filter (p/n FL000001).
6. If replacing the critical flow orifice itself (P/N 00094100), make sure that the side with the colored window (usually red) is facing upstream to the flow gas flow.
7. Apply new Teflon[®] tape to the male connector threads
8. Re-assemble in reverse order.
9. After reconnecting the power and pneumatic lines, flow check the instrument as described in the Section 9.3.4.

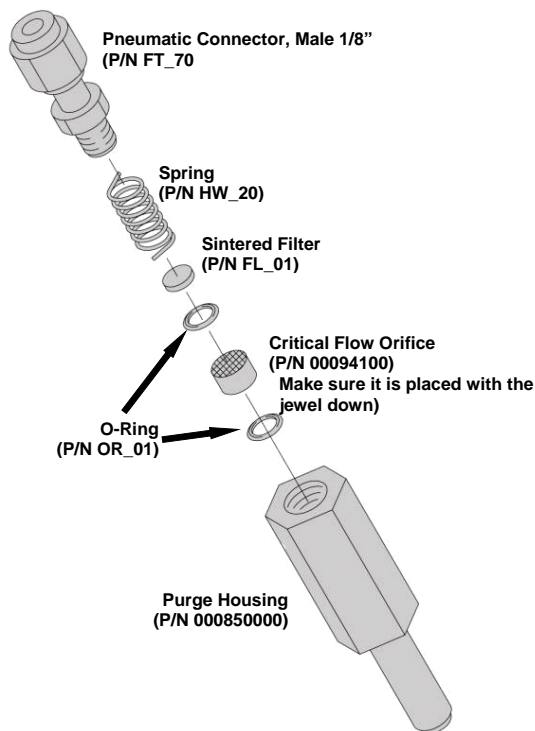

Figure 11-10: Critical Flow Restrictor Assembly Disassembly

11.6.2. Removing/Replacing the GFC Wheel

When removing or replacing the GFC Wheel it is important to perform the disassembly in the following order to avoid damaging the components:

1. Turn off the analyzer.
2. Remove the top cover as described in "Getting Started" Section 3.1.
3. Open the instrument's hinged front panel.
4. Locate the GFC wheel/motor assembly (see Figure 3-3).
5. unplug the following electronic components:
 - The GFC wheel housing temperature sensor;
 - GFC wheel heater
 - GFC wheel motor power supply
 - IR source
6. Unscrew the purge gas line hex nut and remove the 1/8 inch FEP purge gas line.

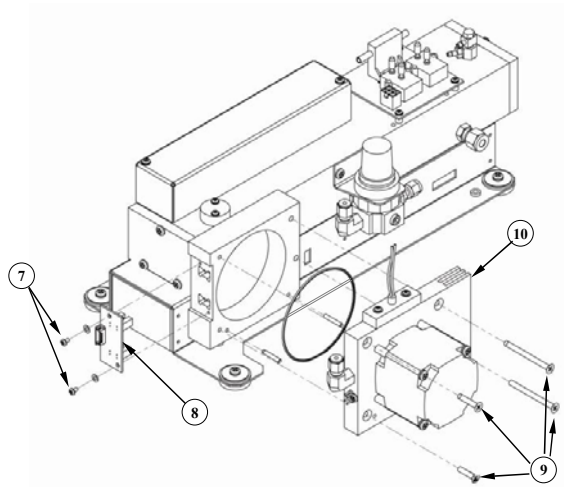

Figure 11-11: Opening the GFC Wheel Housing

7. Remove the two (2) screws holding the opto-pickup printed circuit assembly to the GFC wheel housing.
8. Carefully remove the opto-pickup printed circuit assembly.
9. Remove the four (4) screws holding the GFC wheel motor/heat sink assembly to the GFC wheel housing.
10. Carefully remove the GFC wheel motor/heat sink assembly from the GFC wheel housing.
11. Remove the one (1) screw fastening the GFC wheel/mask assembly to the GFC motor hub.

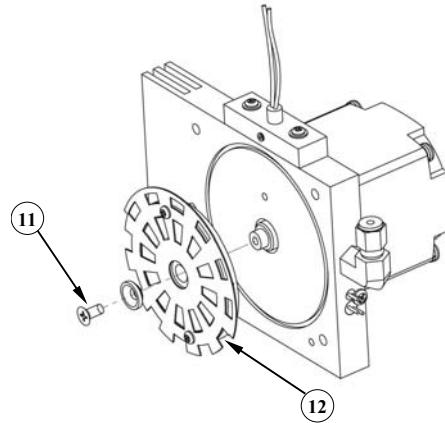

Figure 11-12: Removing the GFC Wheel

12. Remove the GFC wheel/mask assembly.
13. Follow the previous steps in reverse order to put the GFC wheel/motor assembly back together.

11.6.3. Disk-On-Chip Replacement Procedure

Replacing the Disk-on-Chip, may be necessary in certain rare circumstances or to load new instrument software. This will cause all of the instrument configuration parameters and iDAS data to be lost. However a backup copy of the operating parameters are stored in a second non-volatile memory and will be loaded into the new the Disk-on-Chip on power-up. To change the Disk-on-Chip, follow this procedure.

1. Turn off power to the instrument.
2. Fold down the rear panel by loosening the thumbscrews on each side
3. Locate the Disk-on-Chip in the rightmost socket near the right hand side of the CPU assembly. Remove the IC by gently prying it up from the socket.
4. Reinstall the new Disk-on-Chip, making sure the notch in the end of the chip is facing upward.
5. Close the rear panel and turn on power to the machine.

User Notes

12. A PRIMER ON ELECTRO-STATIC DISCHARGE

Teledyne Instruments considers the prevention of damage caused by the discharge of static electricity to be extremely important part of making sure that your analyzer continues to provide reliable service for a long time. This section describes how static electricity occurs, why it is so dangerous to electronic components and assemblies as well as how to prevent that damage from occurring.

12.1. How Static Charges are Created

Modern electronic devices such as the types used in the various electronic assemblies of your analyzer, are very small, require very little power and operate very quickly. Unfortunately, the same characteristics that allow them to do these things also make them very susceptible to damage from the discharge of static electricity. Controlling electrostatic discharge begins with understanding how electro-static charges occur in the first place.

Static electricity is the result of something called triboelectric charging which happens whenever the atoms of the surface layers of two materials rub against each other. As the atoms of the two surfaces move together and separate, some electrons from one surface are retained by the other.

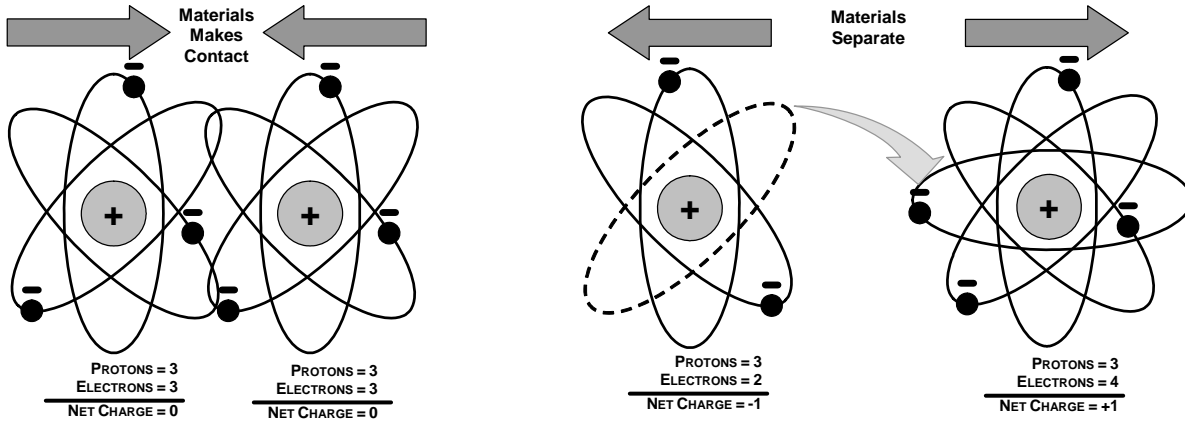

Figure 12-1: Triboelectric Charging

If one of the surfaces is a poor conductor or even a good conductor that is not grounded, the resulting positive or negative charge cannot bleed off and becomes trapped in place, or static. The most common example of triboelectric charging happens when someone wearing leather or rubber soled shoes walks across a nylon carpet or linoleum tiled floor. With each step, electrons change places and the resulting electro-static charge builds up, quickly reaching significant levels. Pushing an epoxy printed circuit board across a workbench, using a plastic handled screwdriver or even the constant jostling of Styrofoam™ pellets during shipment can also build hefty static charges

Table 12-1: Static Generation Voltages for Typical Activities

MEANS OF GENERATION	65-90% RH	10-25% RH
Walking across nylon carpet	1,500V	35,000V
Walking across vinyl tile	250V	12,000V
Worker at bench	100V	6,000V
Poly bag picked up from bench	1,200V	20,000V
Moving around in a chair padded with urethane foam	1,500V	18,000V

12.2. How Electro-Static Charges Cause Damage

Damage to components occurs when these static charges come into contact with an electronic device. Current flows as the charge moves along the conductive circuitry of the device and the typically very high voltage levels of the charge overheat the delicate traces of the integrated circuits, melting them or even vaporizing parts of them. When examined by microscope the damage caused by electro-static discharge looks a lot like tiny bomb craters littered across the landscape of the component's circuitry.

A quick comparison of the values in Table 12-1 with the those shown in the Table 12-2, listing device susceptibility levels, shows why *Semiconductor Reliability News* estimates that approximately 60% of device failures are the result of damage due to electro-static discharge.

Table 12-2: Sensitivity of Electronic Devices to Damage by ESD

DEVICE	DAMAGE SUSCEPTIBILITY VOLTAGE RANGE	
	DAMAGE BEGINS OCCURRING AT	CATASTROPHIC DAMAGE AT
MOSFET	10	100
VMOS	30	1800
NMOS	60	100
GaAsFET	60	2000
EPROM	100	100
JFET	140	7000
SAW	150	500
Op-AMP	190	2500
CMOS	200	3000
Schottky Diodes	300	2500
Film Resistors	300	3000
This Film Resistors	300	7000
ECL	500	500
SCR	500	1000
Schottky TTL	500	2500

Potentially damaging electro-static discharges can occur:

- Any time a charged surface (including the human body) discharges to a device. Even simple contact of a finger to the leads of a sensitive device or assembly can allow enough discharge to cause damage. A similar discharge can occur from a charged conductive object, such as a metallic tool or fixture.
- When static charges accumulated on a sensitive device discharges from the device to another surface such as packaging materials, work surfaces, machine surfaces or other device. In some cases, charged device discharges can be the most destructive.

A typical example of this is the simple act of installing an electronic assembly into the connector or wiring harness of the equipment in which it is to function. If the assembly is carrying a static charge, as it is connected to ground a discharge will occur.

- Whenever a sensitive device is moved into the field of an existing electro-static field, a charge may be induced on the device in effect discharging the field onto the device. If the device is then momentarily grounded while within the electrostatic field or removed from the region of the electrostatic field and grounded somewhere else, a second discharge will occur as the charge is transferred from the device to ground.

12.3. Common Myths About ESD Damage

- **I didn't feel a shock so there was no electro-static discharge:** The human nervous system isn't able to feel a static discharge of less than 3500 volts. Most devices are damaged by discharge levels much lower than that.
- **I didn't touch it so there was no electro-static discharge:** Electro-static charges are fields whose lines of force can extend several inches or sometimes even feet away from the surface bearing the charge.
- **It still works so there was no damage:** Sometimes the damage caused by electro-static discharge can completely sever a circuit trace causing the device to fail immediately. More likely, the trace will be only partially occluded by the damage causing degraded performance of the device or worse, weakening the trace. This weakened circuit may seem to function fine for a short time, but even the very low voltage and current levels of the device's normal operating levels will eat away at the defect over time causing the device to fail well before its designed lifetime is reached.

These latent failures are often the most costly since the failure of the equipment in which the damaged device is installed causes down time, lost data, lost productivity, as well as possible failure and damage to other pieces of equipment or property.

- **Static Charges can't build up on a conductive surface:** There are two errors in this statement.

Conductive devices can build static charges if they are not grounded. The charge will be equalized across the entire device, but without access to earth ground, they are still trapped and can still build to high enough levels to cause damage when they are discharged.

A charge can be induced onto the conductive surface and/or discharge triggered in the presence of a charged field such as a large static charge clinging to the surface of a nylon jacket of someone walking up to a workbench.

- **As long as my analyzer is properly installed, it is safe from damage caused by static discharges:** It is true that when properly installed the chassis ground of your analyzer is tied to earth ground and its electronic components are prevented from building static electric charges themselves. This does not prevent discharges from static fields built up on other things, like you and your clothing, from discharging through the instrument and damaging it.

12.4. Basic Principles of Static Control

It is impossible to stop the creation of instantaneous static electric charges. It is not, however difficult to prevent those charges from building to dangerous levels or prevent damage due to electro-static discharge from occurring.

12.4.1. General Rules

Only handle or work on all electronic assemblies at a properly set up ESD station. Setting up an ESD safe workstation need not be complicated. A protective mat properly tied to ground and a wrist strap are all that is needed to create a basic anti-ESD workstation (see figure 12-2).

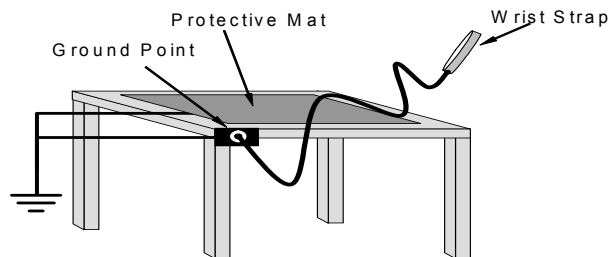

Figure 12-2: Basic anti-ESD Work Station

For technicians that work in the field, special lightweight and portable anti-ESD kits are available from most suppliers of ESD protection gear. These include everything needed to create a temporary anti-ESD work area anywhere.

- **Always wear an Anti-ESD wrist strap when working on the electronic assemblies of your analyzer.** An anti-ESD wrist strap keeps the person wearing it at or near the same potential as other grounded objects in the work area and allows static charges to dissipate before they can build to dangerous levels. Anti-ESD wrist straps terminated with alligator clips are available for use in work areas where there is no available grounded plug.

Also, anti-ESD wrist straps include a current limiting resistor (usually around one meg-ohm) that protects you should you accidentally short yourself to the instrument's power supply.

- **Simply touching a grounded piece of metal is insufficient.** While this may temporarily bleed off static charges present at the time, once you stop touching the grounded metal new static charges will immediately begin to re-build. In some conditions, a charge large enough to damage a component can rebuild in just a few seconds.
- **Always store sensitive components and assemblies in anti-ESD storage bags or bins:** Even when you are not working on them, store all devices and assemblies in a closed anti-Static bag or bin. This will prevent induced charges from building up on the device or assembly and nearby static fields from discharging through it.
- **Use metallic anti-ESD bags for storing and shipping ESD sensitive components and assemblies rather than pink-poly bags.** The famous, "pink-poly" bags are made of a plastic that is impregnated with a liquid (similar to liquid laundry detergent) which very slowly sweats onto the surface of the plastic creating a slightly conductive layer over the surface of the bag.

While this layer may equalizes any charges that occur across the whole bag, it does not prevent the build up of static charges. If laying on a conductive, grounded surface, these bags will allow charges to bleed away but the very charges that build up on the surface of the bag itself can be transferred through the bag by induction onto the circuits of your ESD sensitive device. Also, the liquid impregnating the plastic is eventually used up after which the bag is as useless for preventing damage from ESD as any ordinary plastic bag.

Anti-Static bags made of plastic impregnated with metal (usually silvery in color) provide all of the charge equalizing abilities of the pink-poly bags but also, when properly sealed, create a Faraday cage that completely isolates the contents from discharges and the inductive transfer of static charges.

Storage bins made of plastic impregnated with carbon (usually black in color) are also excellent at dissipating static charges and isolating their contents from field effects and discharges.

- **Never use ordinary plastic adhesive tape near an ESD sensitive device or to close an anti-ESD bag.** The act of pulling a piece of standard plastic adhesive tape, such as Scotch[®] tape, from its roll will generate a static charge of several thousand or even tens of thousands of volts on the tape itself and an associated field effect that can discharge through or be induced upon items up to a foot away.

12.4.2. Basic anti-ESD Procedures for Analyzer Repair and Maintenance

12.4.2.1. Working at the Instrument Rack

When working on the analyzer while it is in the instrument rack and plugged into a properly grounded power supply.

1. Attach your anti-ESD wrist strap to ground before doing anything else.
 - Use a wrist strap terminated with an alligator clip and attach it to a bare metal portion of the instrument chassis. This will safely connect you to the same ground level to which the instrument and all of its components are connected.
2. Pause for a second or two to allow any static charges to bleed away.
3. Open the casing of the analyzer and begin work. Up to this point, the closed metal casing of your analyzer has isolated the components and assemblies inside from any conducted or induced static charges.
4. If you must remove a component from the instrument, do not lay it down on a non-ESD preventative surface where static charges may lie in wait.
5. Only disconnect your wrist strap after you have finished work and closed the case of the analyzer.

12.4.2.2. Working at an Anti-ESD Work Bench.

When working on an instrument of an electronic assembly while it is resting on an anti-ESD work bench:

1. Plug your anti-ESD wrist strap into the grounded receptacle of the work station before touching any items on the work station and while standing at least a foot or so away. This will allow any charges you are carrying to bleed away through the ground connection of the workstation and prevent discharges due to field effects and induction from occurring.
2. Pause for a second or two to allow any static charges to bleed away.
3. Only open any anti-ESD storage bins or bags containing sensitive devices or assemblies after you have plugged your wrist strap into the workstation.
 - Lay the bag or bin on the workbench surface.
 - Before opening the container, wait several seconds for any static charges on the outside surface of the container to be bled away by the workstation's grounded protective mat.
4. Do not pick up tools that may be carrying static charges while also touching or holding an ESD Sensitive Device.
 - Only lay tools or ESD-sensitive devices and assemblies on the conductive surface of your workstation. Never lay them down on any non-ESD preventative surface.
5. Place any static sensitive devices or assemblies in anti-static storage bags or bins and close the bag or bin before unplugging your wrist strap.
6. Disconnecting your wrist strap is always the last action taken before leaving the workbench.

12.4.2.3. Transferring Components from Rack to Bench and Back

When transferring a sensitive device from an installed Teledyne Instruments analyzer to an Anti-ESD workbench or back:

1. Follow the instructions listed above for working at the instrument rack and workstation.
2. Never carry the component or assembly without placing it in an anti-ESD bag or bin.
3. Before using the bag or container allow any surface charges on it to dissipate:
 - If you are at the instrument rack, hold the bag in one hand while your wrist strap is connected to a ground point.
 - If you are at an anti-ESD workbench, lay the container down on the conductive work surface.
 - In either case wait several seconds.
4. Place the item in the container.
5. Seal the container. If using a bag, fold the end over and fastening it with anti-ESD tape.
 - Folding the open end over isolates the component(s) inside from the effects of static fields.
 - Leaving the bag open or simply stapling it shut without folding it closed prevents the bag from forming a complete protective envelope around the device.
6. Once you have arrived at your destination, allow any surface charges that may have built up on the bag or bin during travel to dissipate:
 - Connect your wrist strap to ground.
 - If you are at the instrument rack, hold the bag in one hand while your wrist strap is connected to a ground point.
 - If you are at a anti-ESD work bench, lay the container down on the conductive work surface
 - In either case wait several seconds
7. Open the container.

12.4.2.4. Opening Shipments from Teledyne Instruments Customer Service.

Packing materials such as bubble pack and Styrofoam pellets are extremely efficient generators of static electric charges. To prevent damage from ESD, Teledyne Instruments ships all electronic components and assemblies in properly sealed anti-ESD containers.

Static charges will build up on the outer surface of the anti-ESD container during shipping as the packing materials vibrate and rub against each other. To prevent these static charges from damaging the components or assemblies being shipped make sure that you always unpack shipments from Teledyne Instruments Customer Service by:

1. Opening the outer shipping box away from the anti-ESD work area.
2. Carry the still sealed ant-ESD bag, tube or bin to the anti-ESD work area.
3. Follow steps 6 and 7 of Section 12.4.2.3 above when opening the anti-ESD container at the work station.
4. Reserve the anti-ESD container or bag to use when packing electronic components or assemblies to be returned to Teledyne Instruments.

12.4.2.5. Packing Components for Return to Teledyne Instruments Customer Service.

Always pack electronic components and assemblies to be sent to Teledyne Instruments Customer Service in anti-ESD bins, tubes or bags.

	<p>WARNING</p> <ul style="list-style-type: none">• DO NOT use pink-poly bags.• NEVER allow any standard plastic packaging materials to touch the electronic component/assembly directly<ul style="list-style-type: none">• This includes, but is not limited to, plastic bubble-pack, Styrofoam peanuts, open cell foam, closed cell foam, and adhesive tape• DO NOT use standard adhesive tape as a sealer. Use ONLY anti-ESD tape
---	--

1. Never carry the component or assembly without placing it in an anti-ESD bag or bin.
2. Before using the bag or container allow any surface charges on it to dissipate:
 - If you are at the instrument rack, hold the bag in one hand while your wrist strap is connected to a ground point.
 - If you are at an anti-ESD workbench, lay the container down on the conductive work surface.
 - In either case wait several seconds.
3. Place the item in the container.
4. Seal the container. If using a bag, fold the end over and fastening it with anti-ESD tape.
 - Folding the open end over isolates the component(s) inside from the effects of static fields.
 - Leaving the bag open or simply stapling it shut without folding it closed prevents the bag from forming a complete protective envelope around the device.

NOTE

If you do not already have an adequate supply of anti-ESD bags or containers available, Teledyne Instruments' Customer Service department will supply them. Follow the instructions listed above for working at the instrument rack and workstation.

User Notes:

USER NOTES:

APPENDIX A - Version Specific Software Documentation

APPENDIX A-1: Model 360E Software Menu Trees

APPENDIX A-2: Model 360E Setup Variables Available Via Serial I/O

APPENDIX A-3: Model 360E Warnings and Test Measurements Via Serial I/O

APPENDIX A-4: Model 360E Signal I/O Definitions

APPENDIX A-5: Model 360E iDAS Functions

APPENDIX A-1: M360E Software Menu Trees, Revision G.4

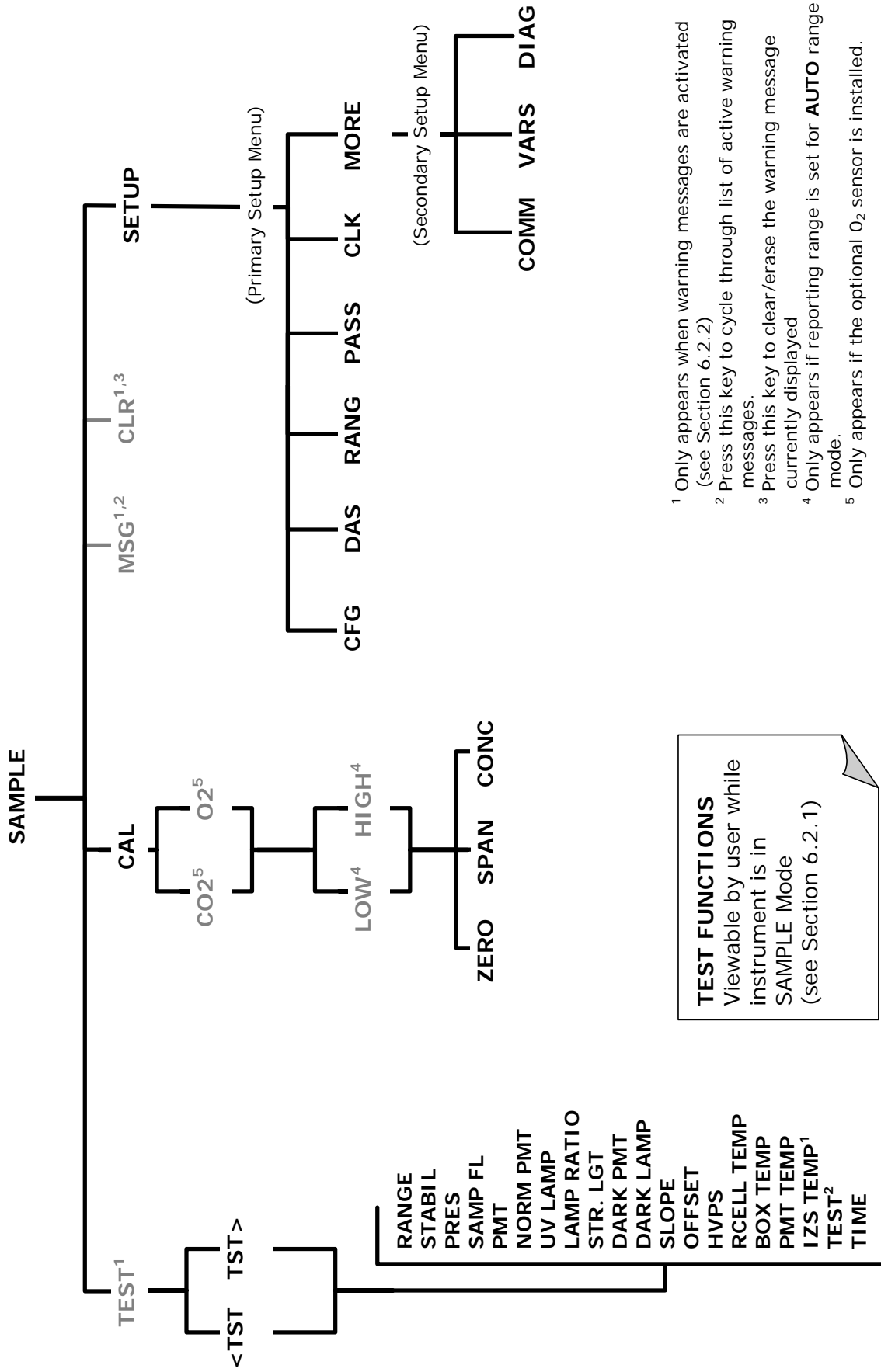

- 1 Only appears when warning messages are activated (see Section 6.2.2)
- 2 Press this key to cycle through list of active warning messages.
- 3 Press this key to clear/erase the warning message currently displayed
- 4 Only appears if reporting range is set for **AUTO** range mode.
- 5 Only appears if the optional O₂ sensor is installed.

TEST FUNCTIONS
Viewable by user while instrument is in SAMPLE Mode (see Section 6.2.1)

Figure A-1: Basic Sample Display Menu

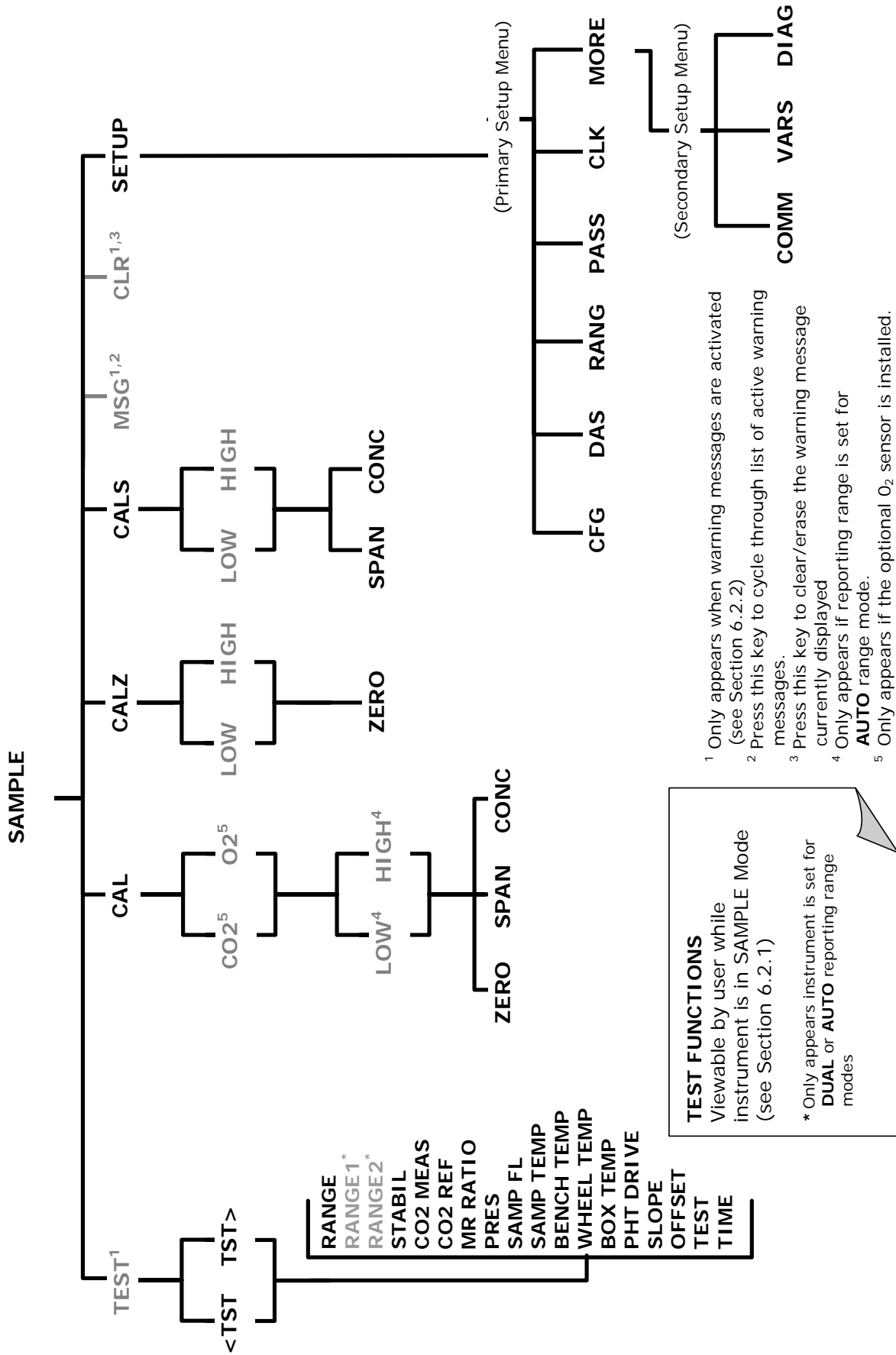
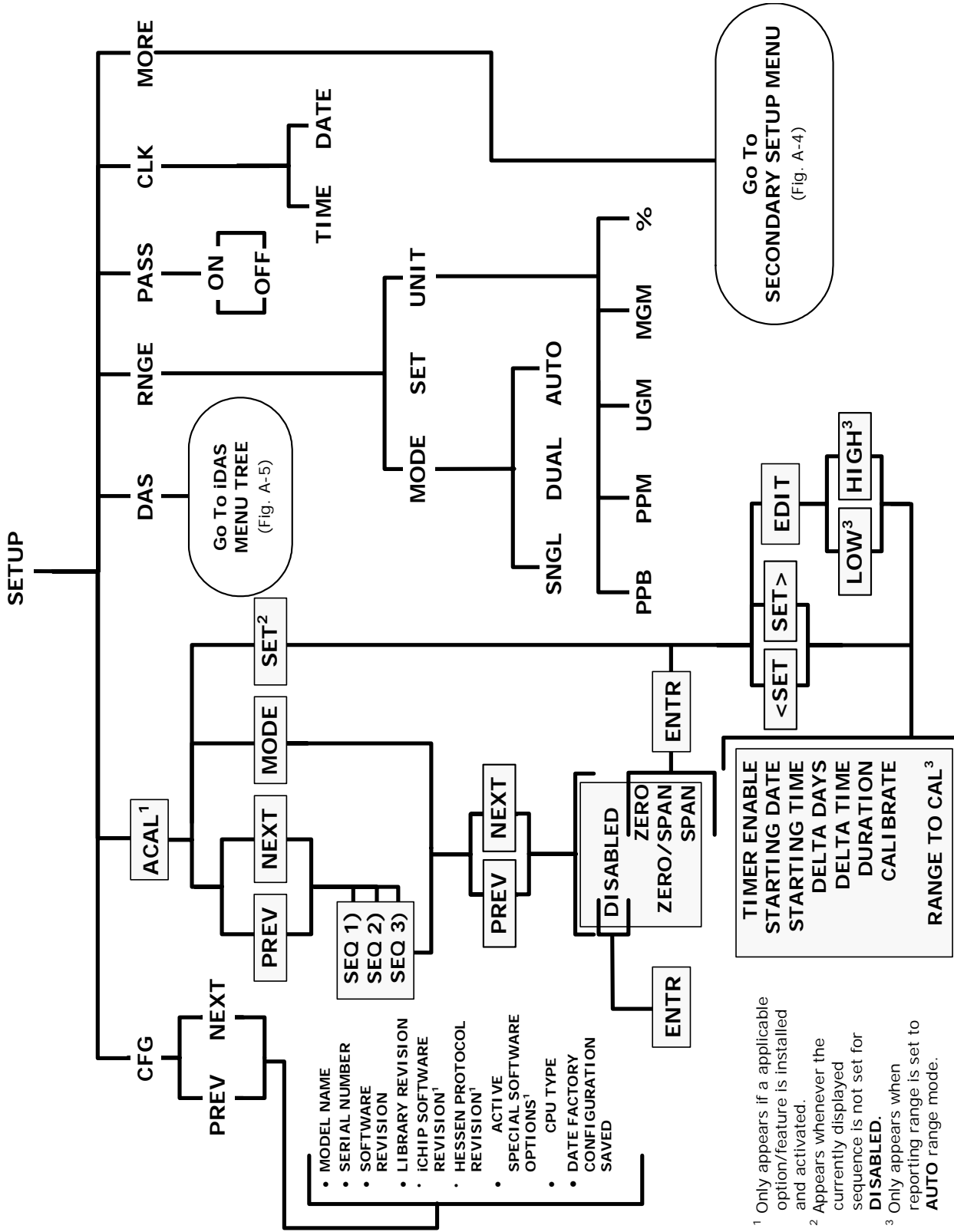
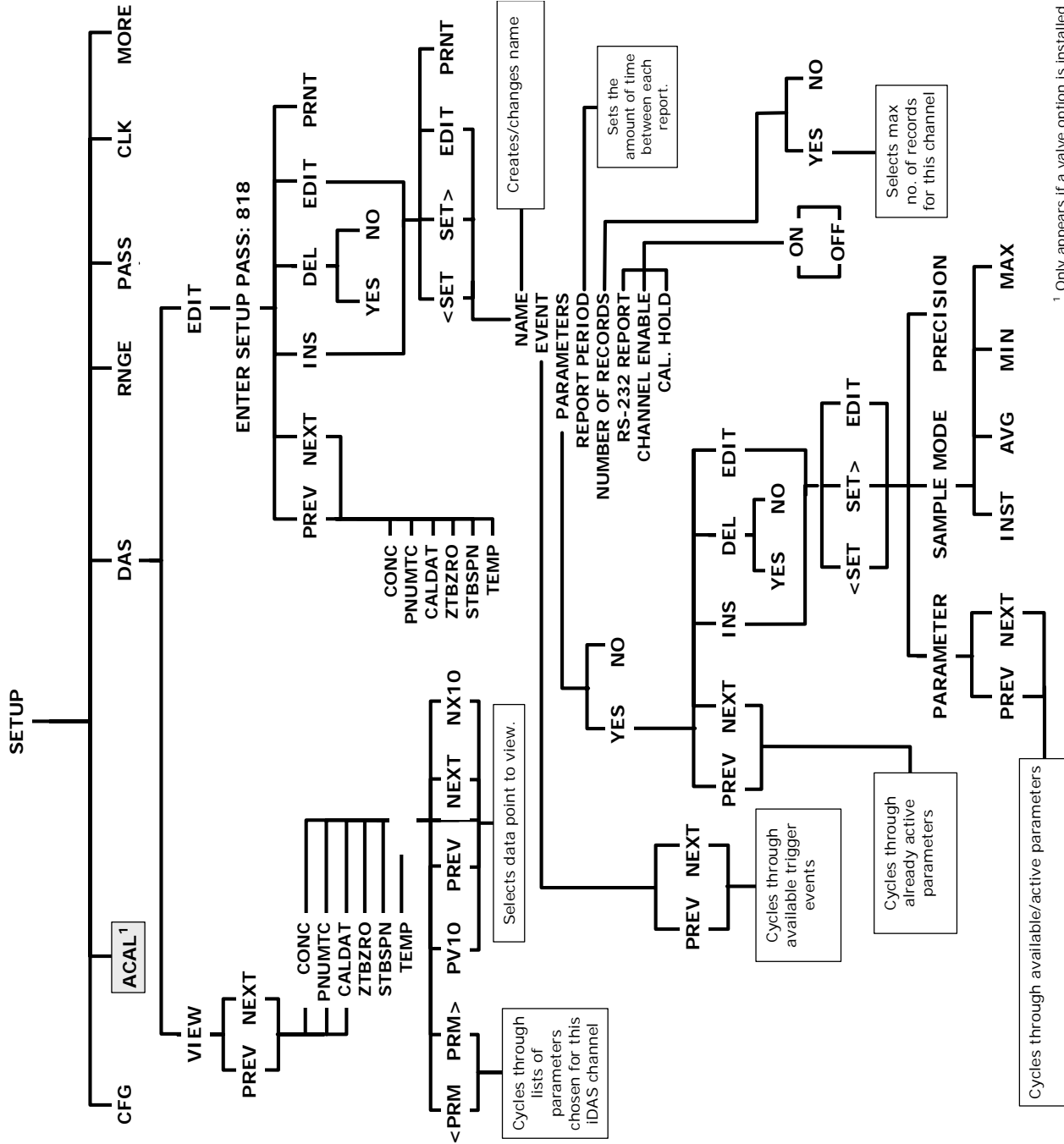

Figure A-2: Sample Display Menu - Units with Z/S Valve or IZS Option installed



¹ Only appears if a applicable option/feature is installed and activated.
² Appears whenever the currently displayed sequence is not set for **DISABLED**.
³ Only appears when reporting range is set to **AUTO** range mode.

Figure A-3: Primary Setup Menu (Except iDAS)



¹ Only appears if a valve option is installed.

Figure A-4: Primary Setup Menu (iDAS)

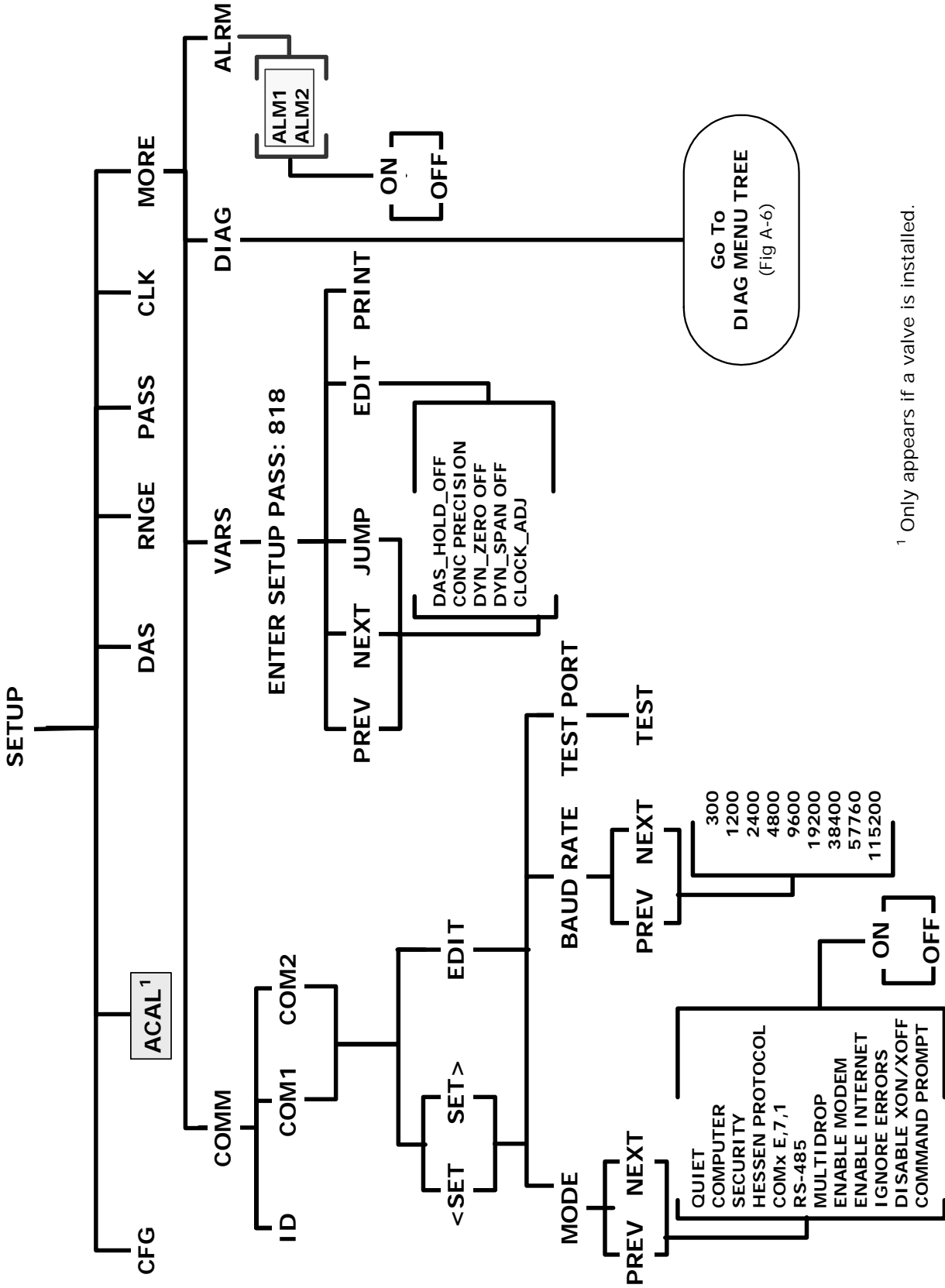

¹ Only appears if a valve is installed.

Figure A-5: Secondary Setup Menu (COMM, VARS & ALRM)

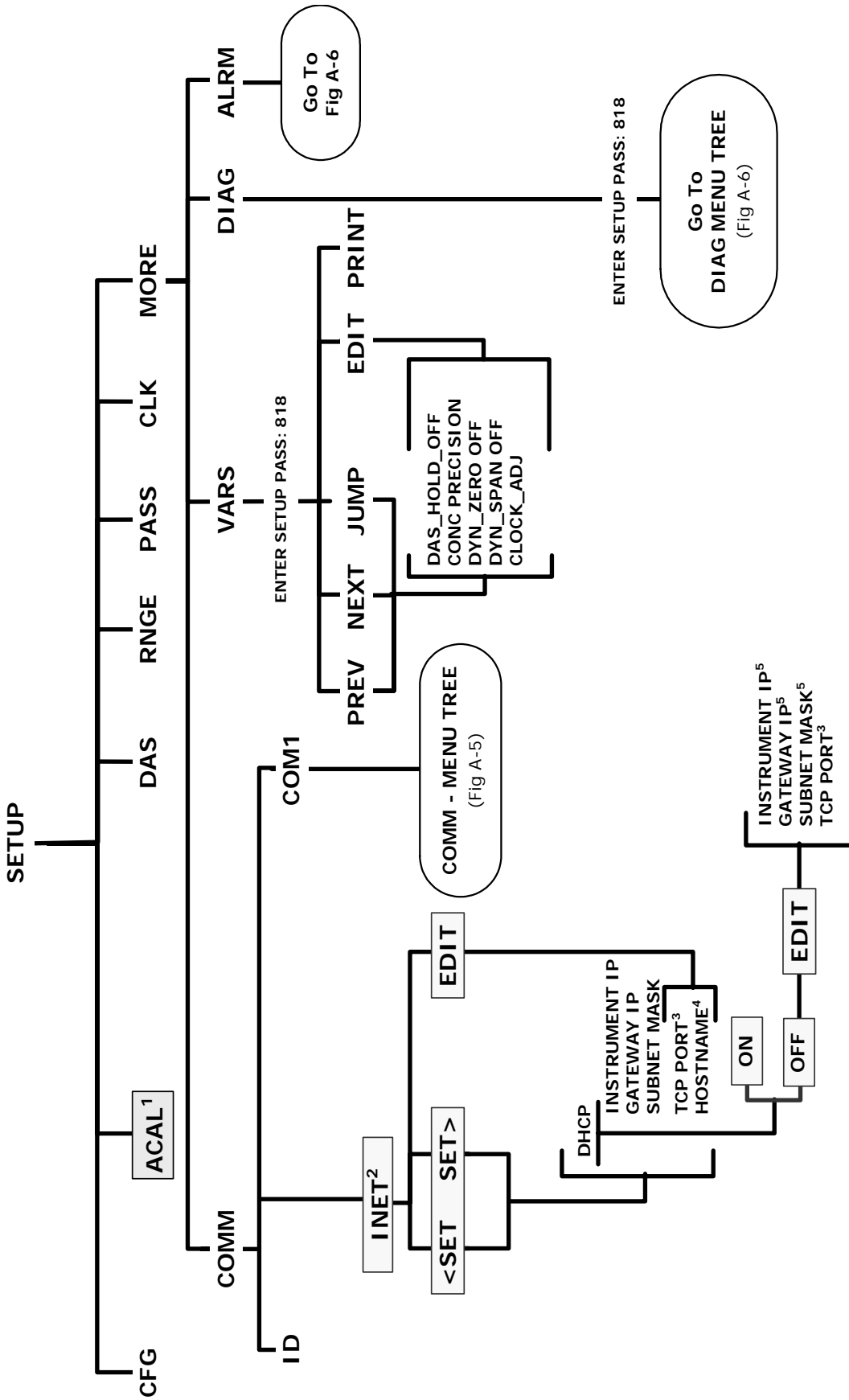

- 1 Only appears if a valve option is installed.
- 2 Only appears when the Ethernet card (option 63) is installed.
- 3 Although TCP PORT is editable regardless of the DHCP state, do not change the setting for this property unless instructed to by Teledyne Instruments Customer Service personnel.
- 4 HOST NAME is only editable when DHCP is ON.
- 5 INSTRUMENT IP, GATEWAY IP & SUBNET MASK are only editable when DHCP is OFF.

Figure A-6: Secondary Setup Menu (COMM Menu with Ethernet Card)

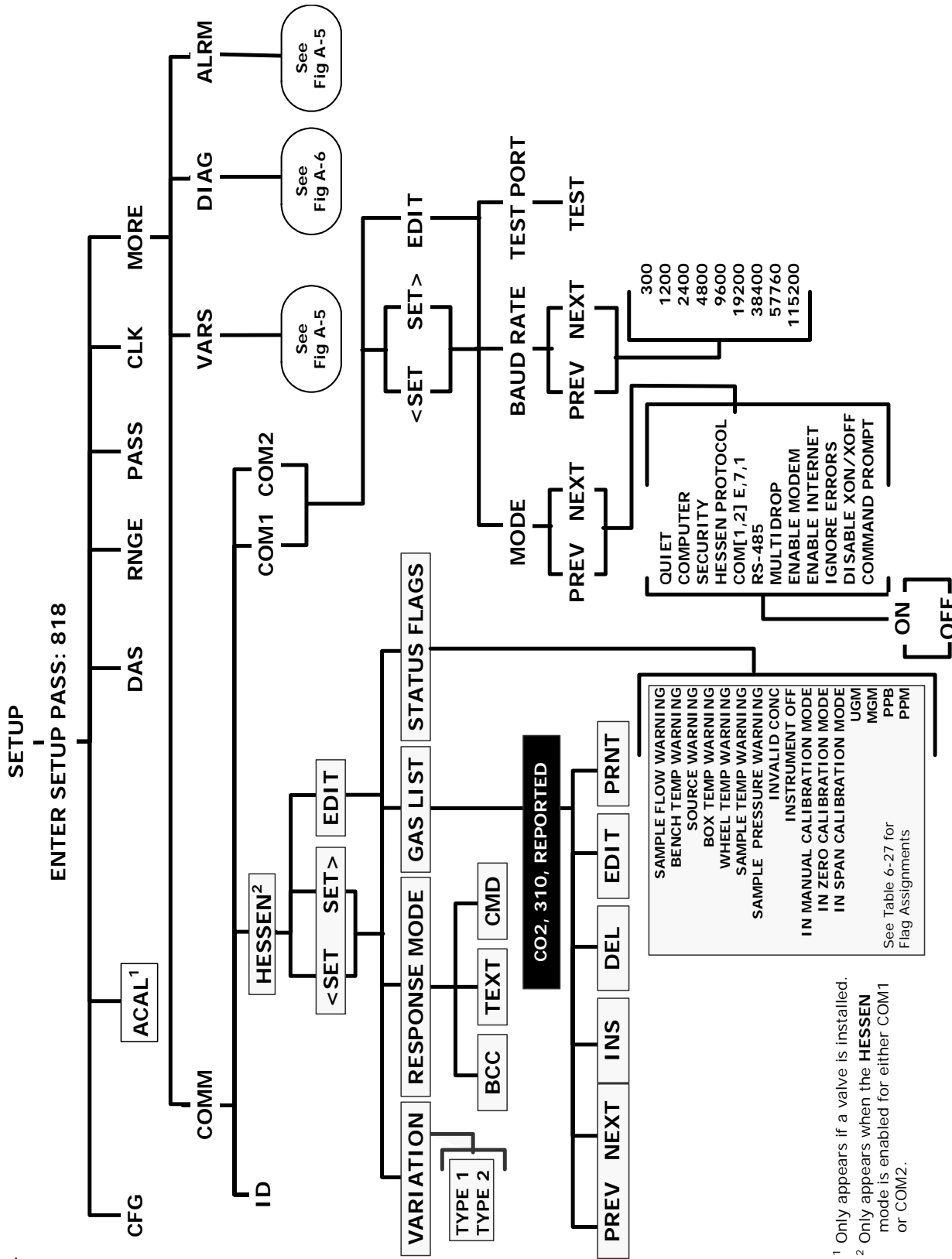

¹ Only appears if a valve is installed.
² Only appears when the **HESSEN** mode is enabled for either COM1 or COM2.

Figure A-7: Secondary Setup Menu (COMM Menu with HESSEN)

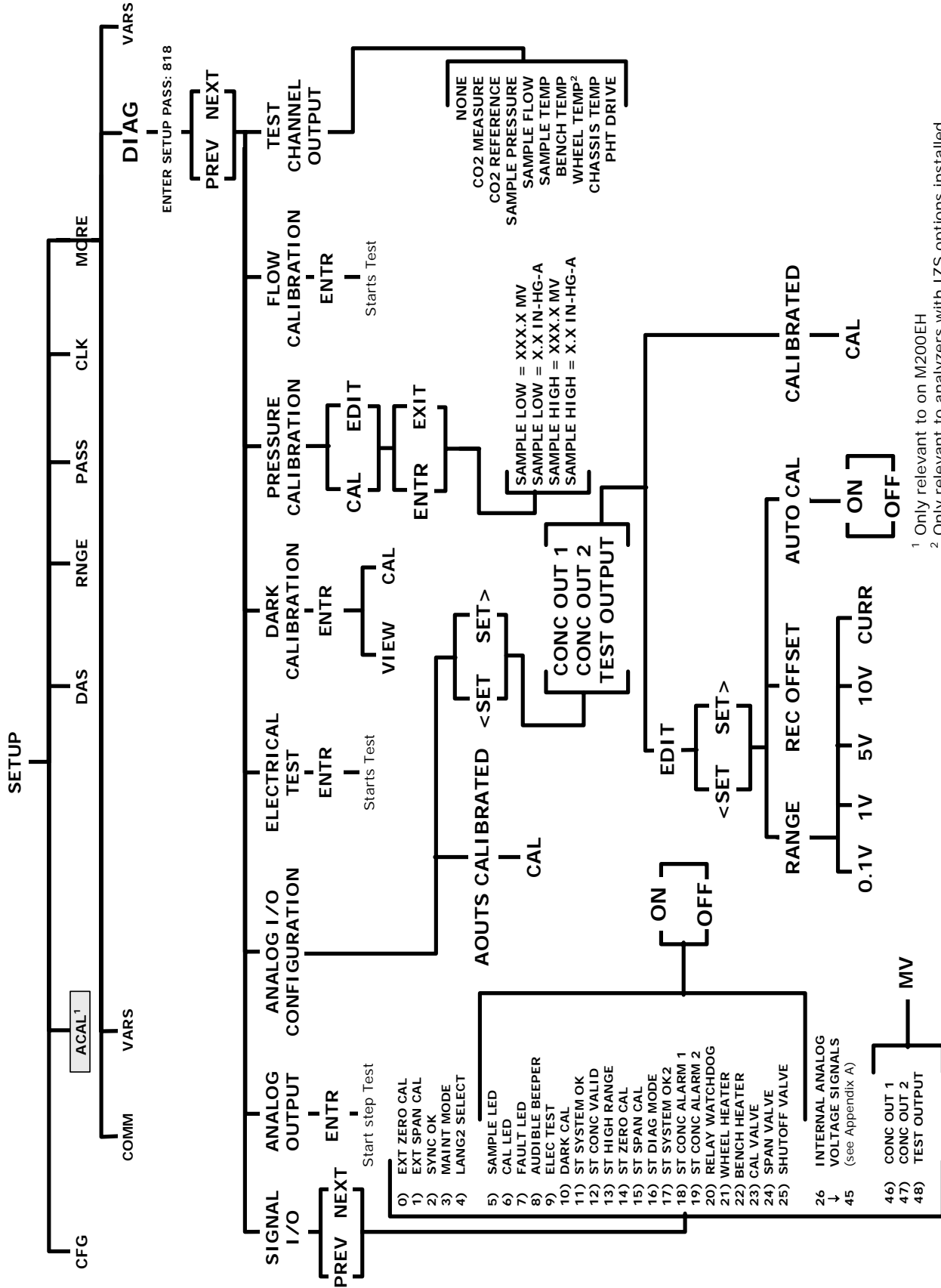

¹ Only relevant to on M200EH
² Only relevant to analyzers with IZS options installed

Figure A-8: Secondary Setup Menu (DIAG)

APPENDIX A-2: Setup Variables For Serial I/O, Revision G.4

Table A-1: M360E Setup Variables, Revision G.4

SETUP VARIABLE	NUMERIC UNITS	DEFAULT VALUE	VALUE RANGE	DESCRIPTION
Low Access Level Setup Variables (818 password)				
DAS_HOLD_OFF	Minutes	15	0.5–20	Duration of DAS hold off period.
CONC_PRECISION	—	3	AUTO, 0, 1, 2, 3, 4	Number of digits to display to the right of the decimal point for concentrations on the display.
DYN_ZERO	—	OFF	ON, OFF	ON enables remote dynamic zero calibration; OFF disables it.
DYN_SPAN	—	OFF	ON, OFF	ON enables remote dynamic span calibration; OFF disables it.
CLOCK_ADJ	Sec./Day	0	-60–60	Time-of-day clock speed adjustment.
Medium Access Level Setup Variables (929 password)				
LANGUAGE_SELECT	—	ENGL ¹	ENGL, SECD, EXTN	Selects the language to use for the user interface.
MAINT_TIMEOUT	Hours	2	0.1–100	Time until automatically switching out of software-controlled maintenance mode.
CONV_TIME	—	33 MS ¹	33 MS, 66 MS, 133 MS, 266 MS, 533 MS, 1 SEC, 2 SEC	Conversion time for measure/reference detector channel.
CO_DWELL	Seconds	0.2	0.1–30	Dwell time before taking measure or reference sample.
CO_SAMPLE	Samples	1	1–30	Number of samples to take in measure or reference mode.
FILT_SIZE	Samples	750	1–1000	Moving average filter size.
FILT_ASIZE	Samples	48	1–1000	Moving average filter size in adaptive mode.
FILT_DELTA	PPM	4	1–1000	Absolute change to trigger adaptive filter.
FILT_PCT	%	10	1–100	Percent change to trigger adaptive filter.
FILT_DELAY	Seconds	90	0–180	Delay before leaving adaptive filter mode.
FILT_ADAPT	—	ON	ON, OFF	ON enables adaptive filter; OFF disables it.
O2_DWELL ⁵	Seconds	1	0.1–30	Dwell time before taking each sample.
O2_FILT_ADAPT ⁵	—	ON	ON, OFF	ON enables O ₂ adaptive filter; OFF disables it.
O2_FILT_SIZE ⁵	Samples	60	1–500	O ₂ moving average filter size in normal mode.
O2_FILT_ASIZE ⁵	Samples	10	1–500	O ₂ moving average filter size in adaptive mode.
O2_FILT_DELTA ⁵	%	2	0.1–100	Absolute change in O ₂ concentration to shorten filter.
O2_FILT_PCT ⁵	%	2	0.1–100	Relative change in O ₂ concentration to shorten filter.

SETUP VARIABLE	NUMERIC UNITS	DEFAULT VALUE	VALUE RANGE	DESCRIPTION
O2_FILT_DELAY ⁵	Seconds	20	0–300	Delay before leaving O ₂ adaptive filter mode.
O2_DIL_FACTOR ⁵	—	1	0.1–1000	Dilution factor for O ₂ . Used only if is dilution enabled with <i>FACTORY_OPT</i> variable.
USER_UNITS	—	PPM ¹	PPB,PPM, UGM,MGM	Concentration units for user interface.
DIL_FACTOR	—	1	0.1–1000	Dilution factor. Used only if is dilution enabled with <i>FACTORY_OPT</i> variable.
DARK_CAL_DURATION	Seconds	60	10–600	Duration of dark cal. First two-thirds is stabilization period; final third is measure period.
DARK_MEAS_MV	mV	0	-1000–1000	Dark offset for measure reading.
DARK_REF_MV	mV	0	-1000–1000	Dark offset for reference reading.
LIN_TARGET_CONC1	Conc	300	1–10000	Target concentration during linearity adjustment for range 1.
LIN_NORM_CONC1	PPM	300	0.01–10000	Target concentration during linearity adjustment normalized for T/P for range 1.
LIN_RATIO1	—	1	0.01–100	Measure/reference ratio measured during linearity adjustment for range 1.
LIN_CORRECT1	—	1	0.001–999.999	Linearity correction factor for range 1.
LIN_TARGET_CONC2	Conc	300	1–10000	Target concentration during linearity adjustment for range 2.
LIN_NORM_CONC2	PPM	300	0.01–10000	Target concentration during linearity adjustment normalized for T/P for range 2.
LIN_RATIO2	—	1	0.01–100	Measure/reference ratio measured during linearity adjustment for range 2.
LIN_CORRECT2	—	1	0.001–999.999	Linearity correction factor for range 2.
LIN_TARGET_CONC	Conc	300	1–10000	Target concentration during linearity adjustment.
LIN_NORM_CONC	PPM	300	0.01–10000	Target concentration during linearity adjustment normalized for T/P.
LIN_RATIO	—	1	0.01–100	Measure/reference ratio measured during linearity adjustment.
LIN_CORRECT	—	1	0.001–999.999	Linearity correction factor.
CO2_COMP_ENABLE	—	OFF	ON, OFF	ON enables CO ₂ compensation; OFF disables it.
CO2_COMP_CONC	%	0	0–20	CO ₂ concentration to compensate for.
CO_CONST1	—	500	100–50000	CO calculation constant.
CO_CONST2	—	1.448	0–10	CO calculation constant.
ET_MEAS_GAIN	—	1	0.0001–9.9999	Electrical test gain factor for measure reading.
ET_REF_GAIN	—	1	0.0001–9.9999	Electrical test gain factor for reference reading.
ET_TARGET_DET	mV	4375	0–5000	Target detector reading during electrical test.
ET_TARGET_CONC	PPM	40	1–10000	Target concentration during electrical test.
ET_CONC_RANGE	Conc.	50	0.1–50000	D/A concentration range during electrical test.

SETUP VARIABLE	NUMERIC UNITS	DEFAULT VALUE	VALUE RANGE	DESCRIPTION
STD_TEMP	°K	321	1–500	Standard temperature for temperature compensation.
STD_PRESS	"Hg	28.1	1–50	Standard pressure for pressure compensation.
BENCH_SET	°C	48 Warnings: 43–53	0–100	Optical bench temperature set point and warning limits.
WHEEL_SET	°C	68 Warnings: 63–73	0–100	Wheel temperature set point and warning limits.
O2_CELL_SET ⁵	°C	50 Warnings: 45–55	30–70	O ₂ sensor cell temperature set point and warning limits.
STD_O2_CELL_TEMP ⁵	°K	323	1–500	Standard O ₂ cell temperature for temperature compensation.
CO_SPAN1	Conc.	40	1–10000	Target CO concentration during span calibration of range 1.
CO_SLOPE1	—	1	0.001–999.999	CO slope for range 1.
CO_OFFSET1	—	0	-10–10	CO offset for range 1.
CO_SPAN2	Conc.	40	1–10000	Target CO concentration during span calibration of range 2.
CO_SLOPE2	—	1	0.001–999.999	CO slope for range 2.
CO_OFFSET2	—	0	-10–10	CO offset for range 2.
O2_TARG_SPAN_CONC ⁵	%	20.95	0.1–100	Target O ₂ concentration during span calibration.
O2_SLOPE ⁵	—	1	0.5–2	O ₂ slope.
O2_OFFSET ⁵	%	0	-10–10	O ₂ offset.
RANGE_MODE	—	SNGL ¹	SNGL, DUAL, AUTO	Range control mode.
CONC_RANGE1	Conc.	50	0.1–50000	D/A concentration range 1.
O2_RANGE ⁵	%	100	0.1–500	O ₂ concentration range.
RS232_MODE	BitFlag	0	0–65535	RS-232 COM1 mode flags. Add values to combine flags. 1 = quiet mode 2 = computer mode 4 = enable security 8 = enable hardware handshaking 16 = enable Hessen protocol ⁴ 32 = enable multi-drop 64 = enable modem 128 = ignore RS-232 line errors 256 = disable XON / XOFF support 512 = disable hardware FIFOs 1024 = enable RS-485 mode 2048 = even parity, 7 data bits, 1 stop bit 4096 = enable command prompt

SETUP VARIABLE	NUMERIC UNITS	DEFAULT VALUE	VALUE RANGE	DESCRIPTION
BAUD_RATE	—	19200 ¹	300, 1200, 2400, 4800, 9600, 19200, 38400, 57600, 115200	RS-232 COM1 baud rate.
MODEM_INIT	—	"AT Y0 &D0 &H0 &I0 S0=2 &B0 &N6 &M0 E0 Q1 &W0" ¹	Any character in the allowed character set. Up to 100 characters long.	RS-232 COM1 modem initialization string. Sent verbatim plus carriage return to modem on power up or manually.
RS232_MODE2	BitFlag	0	0–65535	RS-232 COM2 mode flags. (Same settings as RS232_MODE.)
BAUD_RATE2	—	19200 ¹	300, 1200, 2400, 4800, 9600, 19200, 38400, 57600, 115200	RS-232 COM2 baud rate.
MODEM_INIT2	—	"AT Y0 &D0 &H0 &I0 S0=2 &B0 &N6 &M0 E0 Q1 &W0" ¹	Any character in the allowed character set. Up to 100 characters long.	RS-232 COM2 modem initialization string. Sent verbatim plus carriage return to modem on power up or manually.
RS232_PASS	Password	940331	0–999999	RS-232 log on password.
MACHINE_ID	ID	320	0–9999	Unique ID number for instrument.
COMMAND_PROMPT	—	"Cmd> " ¹	Any character in the allowed character set. Up to 100 characters long.	RS-232 interface command prompt. Displayed only if enabled with RS232_MODE variable.
TEST_CHAN_ID	—	NONE ¹	NONE, CO MEASURE, CO REFERENCE, VACUUM PRESSURE, SAMPLE PRESSURE, SAMPLE FLOW, SAMPLE TEMP, BENCH TEMP, WHEEL TEMP, O2 CELL TEMP ⁵ , CHASSIS TEMP, PHT DRIVE	Diagnostic analog output ID.
REMOTE_CAL_MODE	—	LOW ¹	LOW, HIGH	Range to calibrate during contact closure or Hessen calibration.
PASS_ENABLE	—	OFF	ON, OFF	ON enables passwords; OFF disables them.
STABIL_GAS	—	CO ¹	CO, O2 ⁵	Selects gas for stability measurement.
STABIL_FREQ	Seconds	10	1–300	Stability measurement sampling frequency.
STABIL_SAMPLES	Samples	25	2–40	Number of samples in concentration stability reading.
PHOTO_TEMP_SET	mV	2500 Warnings: 250–4750	0–5000	Photometer temperature warning limits. Set point is not used.

SETUP VARIABLE	NUMERIC UNITS	DEFAULT VALUE	VALUE RANGE	DESCRIPTION
SAMP_PRESS_SET	In-Hg	29.92 Warnings: 15–35	0–100	Sample pressure warning limits. Set point is not used.
SAMP_FLOW_SET	cc/m	750 Warnings: 500–1000	0–5000	Sample flow warning limits. Set point is not used.
SAMP_FLOW_SLOPE	—	1	0.001–100	Slope term to correct sample flow rate.
VAC_SAMP_RATIO	—	0.53	0.1–2	Maximum vacuum pressure / sample pressure ratio for valid sample flow calculation.
PURGE_PRESS_SET	PSIG	7.5 Warnings: 2.5–12.5	0–100	Purge pressure warning limits. Set point is not used.
SAMP_TEMP_SET	°C	30 Warnings: 10.1–100	0–100	Sample temperature warning limits. Set point is not used.
BOX_SET	°C	30 Warnings: 5–48	0–100	Internal box temperature warning limits. Set point is not used.
BENCH_CYCLE	Seconds	2	0.5–30	Optical bench temperature control cycle period.
BENCH_PROP	1/°C	5	0–100	Optical bench temperature PID proportional coefficient. Proportional band is the reciprocal of this setting.
BENCH_INTEG	—	0.5	0–100	Optical bench temperature PID integral coefficient.
BENCH_DERIV	—	2	0–100	Optical bench temperature PID derivative coefficient.
WHEEL_CYCLE	Seconds	2	0.5–30	Wheel temperature control cycle period.
WHEEL_PROP	1/°C	1	0–100	Wheel temperature PID proportional coefficient. Proportional band is the reciprocal of this setting.
WHEEL_INTEG	—	0.035	0–100	Wheel temperature PID integral coefficient.
WHEEL_DERIV	—	2	0–100	Wheel temperature PID derivative coefficient.
O2_CELL_CYCLE ⁵	Seconds	10	0.5–30	O ₂ cell temperature control cycle period.
O2_CELL_PROP ⁵	—	1	0–10	O ₂ cell PID temperature control proportional coefficient.
O2_CELL_INTEG ⁵	—	0.1	0–10	O ₂ cell PID temperature control integral coefficient.
O2_CELL_DERIV ⁵	—	0 (disabled)	0–10	O ₂ cell PID temperature control derivative coefficient.
TPC_ENABLE	—	ON	OFF, ON	ON enables temperature/ pressure compensation; OFF disables it.
CONC_LIN_ENABLE	—	ON	OFF, ON	ON enables concentration linearization; OFF disables it.
SERIAL_NUMBER	—	“00000000” ¹	Any character in the allowed character set. Up to 100 characters long.	Unique serial number for instrument.

SETUP VARIABLE	NUMERIC UNITS	DEFAULT VALUE	VALUE RANGE	DESCRIPTION
DISP_INTENSITY	—	HIGH ¹	HIGH, MED, LOW, DIM	Front panel display intensity.
I2C_RESET_ENABLE	—	ON	OFF, ON	ON enables automatic reset of the I ² C bus in the event of communication failures; OFF disables automatic reset.
CLOCK_FORMAT	—	"TIME=%H:%M:%S"	Any character in the allowed character set. Up to 100 characters long.	Time-of-day clock format flags. Enclose value in double quotes (") when setting from the RS-232 interface. "%a" = Abbreviated weekday name. "%b" = Abbreviated month name. "%d" = Day of month as decimal number (01 – 31). "%H" = Hour in 24-hour format (00 – 23). "%I" = Hour in 12-hour format (01 – 12). "%j" = Day of year as decimal number (001 – 366). "%m" = Month as decimal number (01 – 12). "%M" = Minute as decimal number (00 – 59). "%p" = A.M./P.M. indicator for 12-hour clock. "%S" = Second as decimal number (00 – 59). "%w" = Weekday as decimal number (0 – 6; Sunday is 0). "%y" = Year without century, as decimal number (00 – 99). "%Y" = Year with century, as decimal number. "%%" = Percent sign.
ALARM_TRIGGER	Cycles	10	1–100	Concentration alarm trigger sensitivity adjustment.
REF_SDEV_LIMIT	mV	50	0.1–500	Reference detector standard deviation must be below this limit to switch out of startup mode.
REF_SOURCE_LIMIT	mV	Set Point not used Warnings: 25–4800	1–5000	Reference source warning limits. Set point is not used.

SETUP VARIABLE	NUMERIC UNITS	DEFAULT VALUE	VALUE RANGE	DESCRIPTION
FACTORY_OPT	BitFlag	0	0-65535	Factory option flags. Add values to combine flags. 1 = enable dilution factor 2 = zero/span valves installed 4 = conc. alarms routed to relays 8 = enable linearity adjustment factor 16 = display units in concentration field 32 = enable software-controlled maintenance mode 64 = span valve installed 128 = enable switch-controlled maintenance mode 256 = compute only offset during zero calibration 512 = 220 V A/C power 2048 = enable Internet option ³ 4096 = use "old" style numeric data entry menus when editing conc. table
¹ Enclose value in double quotes (") when setting from the RS-232 interface ² Hessen protocol ³ iChip option ⁴ Must power-cycle instrument for these options to take effect ⁵ O ₂ option				

SETUP VARIABLE	NUMERIC UNITS	DEFAULT VALUE	VALUE RANGE	DESCRIPTION
Low Access Level Setup Variables (818 password)				
DAS_HOLD_OFF	Minutes	15	0.5-20	Duration of DAS hold off period.
CONC_PRECISION	—	3	AUTO, 0, 1, 2, 3, 4	Number of digits to display to the right of the decimal point for concentrations on the display.
DYN_ZERO	—	OFF	ON, OFF	<i>ON</i> enables remote dynamic zero calibration; <i>OFF</i> disables it.
DYN_SPAN	—	OFF	ON, OFF	<i>ON</i> enables remote dynamic span calibration; <i>OFF</i> disables it.
CLOCK_ADJ	Sec./Day	0	-60-60	Time-of-day clock speed adjustment.
Medium Access Level Setup Variables (929 password)				
LANGUAGE_SELECT	—	ENGL ¹	ENGL,SECD, EXTN	Selects the language to use for the user interface.
MAINT_TIMEOUT	Hours	2	0.1-100	Time until automatically switching out of software-controlled maintenance mode.
CONV_TIME	—	33 MS ¹	33 MS, 66 MS, 133 MS, 266 MS, 533 MS, 1 SEC, 2 SEC	Conversion time for measure/reference detector channel.

SETUP VARIABLE	NUMERIC UNITS	DEFAULT VALUE	VALUE RANGE	DESCRIPTION
CO_DWELL	Seconds	0.2	0.1–30	Dwell time before taking measure or reference sample.
CO_SAMPLE	Samples	1	1–30	Number of samples to take in measure or reference mode.
FILT_SIZE	Samples	750	1–1000	Moving average filter size.
FILT_ASIZE	Samples	48	1–1000	Moving average filter size in adaptive mode.
FILT_DELTA	PPM	4	1–1000	Absolute change to trigger adaptive filter.
FILT_PCT	%	10	1–100	Percent change to trigger adaptive filter.
FILT_DELAY	Seconds	90	0–180	Delay before leaving adaptive filter mode.
FILT_ADAPT	—	ON	ON, OFF	ON enables adaptive filter; OFF disables it.
O2_DWELL ⁵	Seconds	1	0.1–30	Dwell time before taking each sample.
O2_FILT_ADAPT ⁵	—	ON	ON, OFF	ON enables O ₂ adaptive filter; OFF disables it.
O2_FILT_SIZE ⁵	Samples	60	1–500	O ₂ moving average filter size in normal mode.
O2_FILT_ASIZE ⁵	Samples	10	1–500	O ₂ moving average filter size in adaptive mode.
O2_FILT_DELTA ⁵	%	2	0.1–100	Absolute change in O ₂ concentration to shorten filter.
O2_FILT_PCT ⁵	%	2	0.1–100	Relative change in O ₂ concentration to shorten filter.
O2_FILT_DELAY ⁵	Seconds	20	0–300	Delay before leaving O ₂ adaptive filter mode.
O2_DIL_FACTOR ⁵	—	1	0.1–1000	Dilution factor for O ₂ . Used only if is dilution enabled with <i>FACTORY_OPT</i> variable.
USER_UNITS	—	PPM ¹	PPB,PPM, UGM,MGM	Concentration units for user interface.
DIL_FACTOR	—	1	0.1–1000	Dilution factor. Used only if is dilution enabled with <i>FACTORY_OPT</i> variable.
DARK_CAL_DURATION	Seconds	60	10–600	Duration of dark cal. First two-thirds is stabilization period; final third is measure period.
DARK_MEAS_MV	mV	0	-1000–1000	Dark offset for measure reading.
DARK_REF_MV	mV	0	-1000–1000	Dark offset for reference reading.
LIN_TARGET_CONC1	Conc	300	1–10000	Target concentration during linearity adjustment for range 1.
LIN_NORM_CONC1	PPM	300	0.01–10000	Target concentration during linearity adjustment normalized for T/P for range 1.
LIN_RATIO1	—	1	0.01–100	Measure/reference ratio measured during linearity adjustment for range 1.
LIN_CORRECT1	—	1	0.001–999.999	Linearity correction factor for range 1.
LIN_TARGET_CONC2	Conc	300	1–10000	Target concentration during linearity adjustment for range 2.
LIN_NORM_CONC2	PPM	300	0.01–10000	Target concentration during linearity adjustment normalized for T/P for range 2.

SETUP VARIABLE	NUMERIC UNITS	DEFAULT VALUE	VALUE RANGE	DESCRIPTION
LIN_RATIO2	—	1	0.01–100	Measure/reference ratio measured during linearity adjustment for range 2.
LIN_CORRECT2	—	1	0.001–999.999	Linearity correction factor for range 2.
LIN_TARGET_CONC	Conc	300	1–10000	Target concentration during linearity adjustment.
LIN_NORM_CONC	PPM	300	0.01–10000	Target concentration during linearity adjustment normalized for T/P.
LIN_RATIO	—	1	0.01–100	Measure/reference ratio measured during linearity adjustment.
LIN_CORRECT	—	1	0.001–999.999	Linearity correction factor.
CO2_COMP_ENABLE	—	OFF	ON, OFF	ON enables CO ₂ compensation; OFF disables it.
CO2_COMP_CONC	%	0	0–20	CO ₂ concentration to compensate for.
CO_CONST1	—	500	100–50000	CO calculation constant.
CO_CONST2	—	1.448	0–10	CO calculation constant.
ET_MEAS_GAIN	—	1	0.0001–9.9999	Electrical test gain factor for measure reading.
ET_REF_GAIN	—	1	0.0001–9.9999	Electrical test gain factor for reference reading.
ET_TARGET_DET	mV	4375	0–5000	Target detector reading during electrical test.
ET_TARGET_CONC	PPM	40	1–10000	Target concentration during electrical test.
ET_CONC_RANGE	Conc.	50	0.1–50000	D/A concentration range during electrical test.
STD_TEMP	°K	321	1–500	Standard temperature for temperature compensation.
STD_PRESS	"Hg	28.1	1–50	Standard pressure for pressure compensation.
BENCH_SET	°C	48 Warnings: 43–53	0–100	Optical bench temperature set point and warning limits.
WHEEL_SET	°C	68 Warnings: 63–73	0–100	Wheel temperature set point and warning limits.
O2_CELL_SET ⁵	°C	50 Warnings: 45–55	30–70	O ₂ sensor cell temperature set point and warning limits.
STD_O2_CELL_TEMP ⁵	°K	323	1–500	Standard O ₂ cell temperature for temperature compensation.
CO_SPAN1	Conc.	40	1–10000	Target CO concentration during span calibration of range 1.
CO_SLOPE1	—	1	0.001–999.999	CO slope for range 1.
CO_OFFSET1	—	0	-10–10	CO offset for range 1.
CO_SPAN2	Conc.	40	1–10000	Target CO concentration during span calibration of range 2.
CO_SLOPE2	—	1	0.001–999.999	CO slope for range 2.
CO_OFFSET2	—	0	-10–10	CO offset for range 2.
O2_TARG_SPAN_CONC ⁵	%	20.95	0.1–100	Target O ₂ concentration during span calibration.

SETUP VARIABLE	NUMERIC UNITS	DEFAULT VALUE	VALUE RANGE	DESCRIPTION
O2_SLOPE ⁵	—	1	0.5–2	O ₂ slope.
O2_OFFSET ⁵	%	0	-10–10	O ₂ offset.
RANGE_MODE	—	SNGL ¹	SNGL, DUAL, AUTO	Range control mode.
CONC_RANGE1	Conc.	50	0.1–50000	D/A concentration range 1.
O2_RANGE ⁵	%	100	0.1–500	O ₂ concentration range.
RS232_MODE	BitFlag	0	0–65535	RS-232 COM1 mode flags. Add values to combine flags. 1 = quiet mode 2 = computer mode 4 = enable security 8 = enable hardware handshaking 16 = enable Hessen protocol ⁴ 32 = enable multi-drop 64 = enable modem 128 = ignore RS-232 line errors 256 = disable XON / XOFF support 512 = disable hardware FIFOs 1024 = enable RS-485 mode 2048 = even parity, 7 data bits, 1 stop bit 4096 = enable command prompt
BAUD_RATE	—	19200 ¹	300, 1200, 2400, 4800, 9600, 19200, 38400, 57600, 115200	RS-232 COM1 baud rate.
MODEM_INIT	—	"AT Y0 &D0 &H0 &I0 S0=2 &B0 &N6 &M0 E0 Q1 &W0" ¹	Any character in the allowed character set. Up to 100 characters long.	RS-232 COM1 modem initialization string. Sent verbatim plus carriage return to modem on power up or manually.
RS232_MODE2	BitFlag	0	0–65535	RS-232 COM2 mode flags. (Same settings as RS232_MODE.)
BAUD_RATE2	—	19200 ¹	300, 1200, 2400, 4800, 9600, 19200, 38400, 57600, 115200	RS-232 COM2 baud rate.
MODEM_INIT2	—	"AT Y0 &D0 &H0 &I0 S0=2 &B0 &N6 &M0 E0 Q1 &W0" ¹	Any character in the allowed character set. Up to 100 characters long.	RS-232 COM2 modem initialization string. Sent verbatim plus carriage return to modem on power up or manually.
RS232_PASS	Password	940331	0–999999	RS-232 log on password.
MACHINE_ID	ID	320	0–9999	Unique ID number for instrument.
COMMAND_PROMPT	—	"Cmd> " ¹	Any character in the allowed character set. Up to 100 characters long.	RS-232 interface command prompt. Displayed only if enabled with RS232_MODE variable.
TEST_CHAN_ID	—	NONE ¹	NONE, CO MEASURE, CO REFERENCE, VACUUM PRESSURE,	Diagnostic analog output ID.

SETUP VARIABLE	NUMERIC UNITS	DEFAULT VALUE	VALUE RANGE	DESCRIPTION
			SAMPLE PRESSURE, SAMPLE FLOW, SAMPLE TEMP, BENCH TEMP, WHEEL TEMP, O2 CELL TEMP ⁵ , CHASSIS TEMP, PHT DRIVE	
REMOTE_CAL_MODE	—	LOW ¹	LOW, HIGH	Range to calibrate during contact closure or Hessen calibration.
PASS_ENABLE	—	OFF	ON, OFF	ON enables passwords; OFF disables them.
STABIL_GAS	—	CO ¹	CO, O2 ⁵	Selects gas for stability measurement.
STABIL_FREQ	Seconds	10	1–300	Stability measurement sampling frequency.
STABIL_SAMPLES	Samples	25	2–40	Number of samples in concentration stability reading.
PHOTO_TEMP_SET	mV	2500 Warnings: 250–4750	0–5000	Photometer temperature warning limits. Set point is not used.
SAMP_PRESS_SET	In-Hg	29.92 Warnings: 15–35	0–100	Sample pressure warning limits. Set point is not used.
SAMP_FLOW_SET	cc/m	750 Warnings: 500–1000	0–5000	Sample flow warning limits. Set point is not used.
SAMP_FLOW_SLOPE	—	1	0.001–100	Slope term to correct sample flow rate.
VAC_SAMP_RATIO	—	0.53	0.1–2	Maximum vacuum pressure / sample pressure ratio for valid sample flow calculation.
PURGE_PRESS_SET	PSIG	7.5 Warnings: 2.5–12.5	0–100	Purge pressure warning limits. Set point is not used.
SAMP_TEMP_SET	°C	30 Warnings: 10.1–100	0–100	Sample temperature warning limits. Set point is not used.
BOX_SET	°C	30 Warnings: 5–48	0–100	Internal box temperature warning limits. Set point is not used.
BENCH_CYCLE	Seconds	2	0.5–30	Optical bench temperature control cycle period.
BENCH_PROP	1/°C	5	0–100	Optical bench temperature PID proportional coefficient. Proportional band is the reciprocal of this setting.
BENCH_INTEG	—	0.5	0–100	Optical bench temperature PID integral coefficient.
BENCH_DERIV	—	2	0–100	Optical bench temperature PID derivative coefficient.
WHEEL_CYCLE	Seconds	2	0.5–30	Wheel temperature control cycle

SETUP VARIABLE	NUMERIC UNITS	DEFAULT VALUE	VALUE RANGE	DESCRIPTION
				period.
WHEEL_PROP	1/°C	1	0–100	Wheel temperature PID proportional coefficient. Proportional band is the reciprocal of this setting.
WHEEL_INTEG	—	0.035	0–100	Wheel temperature PID integral coefficient.
WHEEL_DERIV	—	2	0–100	Wheel temperature PID derivative coefficient.
O ₂ _CELL_CYCLE ⁵	Seconds	10	0.5–30	O ₂ cell temperature control cycle period.
O ₂ _CELL_PROP ⁵	—	1	0–10	O ₂ cell PID temperature control proportional coefficient.
O ₂ _CELL_INTEG ⁵	—	0.1	0–10	O ₂ cell PID temperature control integral coefficient.
O ₂ _CELL_DERIV ⁵	—	0 (disabled)	0–10	O ₂ cell PID temperature control derivative coefficient.
TPC_ENABLE	—	ON	OFF, ON	<i>ON</i> enables temperature/ pressure compensation; <i>OFF</i> disables it.
CONC_LIN_ENABLE	—	ON	OFF, ON	<i>ON</i> enables concentration linearization; <i>OFF</i> disables it.
SERIAL_NUMBER	—	"00000000" ¹	Any character in the allowed character set. Up to 100 characters long.	Unique serial number for instrument.
DISP_INTENSITY	—	HIGH ¹	HIGH, MED, LOW, DIM	Front panel display intensity.
I2C_RESET_ENABLE	—	ON	OFF, ON	<i>ON</i> enables automatic reset of the I ² C bus in the event of communication failures; <i>OFF</i> disables automatic reset.
CLOCK_FORMAT	—	"TIME=%H:%M:%S" ¹	Any character in the allowed character set. Up to 100 characters long.	Time-of-day clock format flags. Enclose value in double quotes (") when setting from the RS-232 interface. "%a" = Abbreviated weekday name. "%b" = Abbreviated month name. "%d" = Day of month as decimal number (01 – 31). "%H" = Hour in 24-hour format (00 – 23). "%I" = Hour in 12-hour format (01 – 12). "%j" = Day of year as decimal number (001 – 366). "%m" = Month as decimal number (01 – 12). "%M" = Minute as decimal number (00 – 59). "%p" = A.M./P.M. indicator for 12-hour clock. "%S" = Second as decimal number (00 – 59). "%w" = Weekday as decimal number (0 – 6; Sunday is 0). "%y" = Year without century, as

SETUP VARIABLE	NUMERIC UNITS	DEFAULT VALUE	VALUE RANGE	DESCRIPTION
				decimal number (00 – 99). “%Y” = Year with century, as decimal number. “%%” = Percent sign.
ALARM_TRIGGER	Cycles	10	1–100	Concentration alarm trigger sensitivity adjustment.
REF_SDEV_LIMIT	mV	50	0.1–500	Reference detector standard deviation must be below this limit to switch out of startup mode.
REF_SOURCE_LIMIT	mV	Set Point not used Warnings: 25–4800	1–5000	Reference source warning limits. Set point is not used.
FACTORY_OPT	BitFlag	0	0–65535	Factory option flags. Add values to combine flags. 1 = enable dilution factor 2 = zero/span valves installed 4 = conc. alarms routed to relays 8 = enable linearity adjustment factor 16 = display units in concentration field 32 = enable software-controlled maintenance mode 64 = span valve installed 128 = enable switch-controlled maintenance mode 256 = compute only offset during zero calibration 512 = 220 V A/C power 2048 = enable Internet option ³ 4096 = use “old” style numeric data entry menus when editing conc. table
¹ Enclose value in double quotes (") when setting from the RS-232 interface ² Hessen protocol ³ iChip option ⁴ Must power-cycle instrument for these options to take effect ⁵ O ₂ option				

APPENDIX A-3: Warnings and Test Functions, Revision G.4

Table A-2: M360E Warning Messages, Revision G.4

NAME	MESSAGE TEXT	DESCRIPTION
WANALOGCAL	ANALOG CAL WARNING	The A/D or at least one D/A channel has not been calibrated.
WBENCHTEMP	BENCH TEMP WARNING	Bench temperature outside of warning limits specified by BENCH_SET variable.
WBOXTEMP	BOX TEMP WARNING	Chassis temperature outside of warning limits specified by BOX_SET variable.
WDYNSPAN	CANNOT DYN SPAN	Contact closure span calibration failed while DYN_SPAN was set to ON.
WDYNZERO	CANNOT DYN ZERO	Contact closure zero calibration failed while DYN_ZERO was set to ON.
WCONCALARM1	CONC ALARM 1 WARN	Concentration limit 1 exceeded.
WCONCALARM2	CONC ALARM 2 WARN	Concentration limit 2 exceeded.
WCONFIGINIT	CONFIG INITIALIZED	Configuration storage was reset to factory configuration or erased.
WDATAINIT	DATA INITIALIZED	Data storage was erased.
WFRONTPANEL	FRONT PANEL WARN	Firmware is unable to communicate with the front panel.
WO2CELLTEMP 1	O2 CELL TEMP WARN	O2 sensor cell temperature outside of warning limits specified by O2_CELL_SET variable.
WPHOTOTEMP	PHOTO TEMP WARNING	Photometer temperature outside of warning limits specified by PHOTO_TEMP_SET variable.
WREARBOARD	REAR BOARD NOT DET	Rear board was not detected during power up.
WRELAYBOARD	RELAY BOARD WARN	Firmware is unable to communicate with the relay board.
WSAMPFLOW	SAMPLE FLOW WARN	Sample flow outside of warning limits specified by SAMP_FLOW_SET variable.
WSAMPPRESS	SAMPLE PRESS WARN	Sample pressure outside of warning limits specified by SAMP_PRESS_SET variable.
WSAMPTEMP	SAMPLE TEMP WARN	Sample temperature outside of warning limits specified by SAMP_TEMP_SET variable.
WSOURCE	SOURCE WARNING	Reference reading minus dark offset outside of warning limits specified by REF_SOURCE_LIMIT variable.
WSYSRES	SYSTEM RESET	Instrument was power-cycled or the CPU was reset.
WWHEELTEMP	WHEEL TEMP WARNING	Wheel temperature outside of warning limits specified by WHEEL_SET variable.
¹	O ₂ option	

Table A-3: M360E Test Functions, Revision G.4

TEST FUNCTION NAME ¹	MESSAGE TEXT	DESCRIPTION
RANGE	RANGE=50.0 PPM ³	D/A range in single or auto-range modes.
RANGE1	RANGE1=50.0 PPM ³	D/A #1 range in dual range mode.
RANGE2	RANGE2=50.0 PPM ³	D/A #2 range in dual range mode.
O2RANGE ¹	O2 RANGE ¹ =100 % ¹⁰	O ₂ sensor range setting.
STABILITY	STABIL=0.0 PPM ³ CO ₂ STB=0.0 % O ₂ STB=0.0 % ¹⁰	Concentration stability (standard deviation based on setting of STABIL_FREQ and STABIL_SAMPLES).
CO2MEAS	MEAS= 4000 mV	The demodulated, peak IR detector output during the measure portion of the CFG Wheel cycle.
CO2REF	REF= 2000 mV	The demodulated, peak IR detector output during the reference portion of the CFG wheel cycle.
MRRATIO	MR RATIO=1.100	Measure/reference ratio.
SAMPPRESS	PRES=29.9 IN-HG-A	Sample pressure.
PURGEPRESS	PURGE=7.5 PSIG	Purge pressure
SAMPFLOW	SAMP FL=751 CC/M	Sample flow rate.
SAMPTEMP	SAMPLE TEMP=26.8 C	Sample temperature.
BENCHTEMP	BENCH TEMP=48.1 C	Bench temperature.
WHEELTEMP	WHEEL TEMP=68.1 C	Wheel temperature.
O2CELLTEMP ¹	O2 CELL TEMP=50.2 C	O ₂ sensor cell temperature.
BOXTEMP	BOX TEMP=26.8 C	Internal chassis temperature.
PHOTOTEMP	PHT DRIVE=2500.0 MV	Photometer temperature.
CO2SLOPE	SLOPE CO ₂ SLOPE=1.000 ¹	CO ₂ slope, computed during zero/span calibration.
CO2OFFSET	OFFSET CO ₂ OFFSET=0.000 ¹	CO ₂ offset, computed during zero/span calibration.
O2SLOPE ¹	O ₂ SLOPE ¹ =0.980	O ₂ slope, computed during zero/span calibration.
O2OFFSET ¹	O ₂ OFFSET ¹ =1.79 %	O ₂ offset, computed during zero/span calibration.
TESTCHAN	TEST=1751.4 MV	Value output to TEST_OUTPUT analog output, selected with TEST_CHAN_ID variable.
CLOCKTIME	TIME=09:52:20	Current instrument time of day clock.
¹ Only appears if O ₂ option is installed.		

APPENDIX A-4: Signal I/O Definitions for 300E Series Analyzers, Revision G.4

Table A-4: Signal I/O Definitions for 300E Series Analyzers, Revision G.4

SIGNAL NAME	BIT OR CHANNEL NUMBER	DESCRIPTION
SYNC_OK	0	1 = sync. OK 0 = sync. error
	1–7	Spare
Internal outputs, U8, J108, pins 1–8 = bits 0–7, default I/O address 322 hex		
ELEC_TEST	0	1 = electrical test on 0 = off
DARK_CAL	1	1 = dark calibration on 0 = off
	2–5	Spare
I2C_RESET	6	1 = reset I2C peripherals 0 = normal
I2C_DRV_RST	7	0 = hardware reset 8584 chip 1 = normal
Control inputs, U11, J1004, pins 1–6 = bits 0–5, default I/O address 321 hex		
EXT_ZERO_CAL	0	0 = go into zero calibration 1 = exit zero calibration
EXT_SPAN_CAL	1	0 = go into span calibration 1 = exit span calibration
REMOTE_RANGE_HI	2	0 = remote select high range 1 = default range
	3–5	Spare
	6–7	Always 1
Control inputs, U14, J1006, pins 1–6 = bits 0–5, default I/O address 325 hex		
	0–5	Spare
	6–7	Always 1
Control outputs, U17, J1008, pins 1–8 = bits 0–7, default I/O address 321 hex		
	0–7	Spare
Control outputs, U21, J1008, pins 9–12 = bits 0–3, default I/O address 325 hex		
	0–3	Spare
Alarm outputs, U21, J1009, pins 1–12 = bits 4–7, default I/O address 325 hex		
ST_SYSTEM_OK2	4	1 = system OK 0 = any alarm condition or in diagnostics mode
ST_CONC_ALARM_1 ₂₊₈	5	1 = conc. limit 1 exceeded 0 = conc. OK
ST_CONC_ALARM_2 ₂₊₈	6	1 = conc. limit 2 exceeded 0 = conc. OK
	7	Spare
A status outputs, U24, J1017, pins 1–8 = bits 0–7, default I/O address 323 hex		
ST_SYSTEM_OK	0	0 = system OK 1 = any alarm condition
ST_CONC_VALID	1	0 = conc. valid 1 = hold off or other conditions
ST_HIGH_RANGE	2	0 = high auto-range in use 1 = low auto-range
ST_ZERO_CAL	3	0 = in zero calibration 1 = not in zero
ST_SPAN_CAL	4	0 = in span calibration

SIGNAL NAME	BIT OR CHANNEL NUMBER	DESCRIPTION
		1 = not in span
ST_DIAG_MODE	5	0 = in diagnostic mode 1 = not in diagnostic mode
ST_CONC_ALARM_1 ₂	6	0 = conc. limit 1 exceeded 1 = conc. OK
ST_CONC_ALARM_2 ₂	7	0 = conc. limit 2 exceeded 1 = conc. OK
B status outputs, U27, J1018, pins 1–8 = bits 0–7, default I/O address 324 hex		
ST_AUTO_REF ^{2,3}	0	0 = in auto-reference mode 1 = not in auto-reference mode
	1–7	Spare
Front panel I²C keyboard, default I²C address 4E hex		
MAINT_MODE	5 (input)	0 = maintenance mode 1 = normal mode
LANG2_SELECT	6 (input)	0 = select second language 1 = select first language (English)
SAMPLE_LED	8 (output)	0 = sample LED on 1 = off
CAL_LED	9 (output)	0 = cal. LED on 1 = off
FAULT_LED	10 (output)	0 = fault LED on 1 = off
AUDIBLE_BEEPER	14 (output)	0 = beeper on (for diagnostic testing only) 1 = off
Relay board digital output (PCF8574), default I²C address 44 hex		
RELAY_WATCHDOG	0	Alternate between 0 and 1 at least every 5 seconds to keep relay board active
WHEEL_HTR	1	0 = wheel heater on 1 = off
BENCH_HTR	2	0 = optical bench heater on 1 = off
O2_CELL_HEATER ⁵	3	0 = O ₂ sensor cell heater on 1 = off
CAL_VALVE	4	0 = let cal. gas in 1 = let sample gas in
SPAN_VALVE	5	0 = let span gas in 1 = let zero gas in
ZERO_SCRUB_VALVE ²	6	0 = open zero scrubber valve 1 = close
SHUTOFF_VALVE	6	0 = energize shutoff valve 1 = de-energize
IR_SOURCE_ON	7	0 = IR source on 1 = off
Rear board primary MUX analog inputs		
SAMPLE_PRESSURE	0	Sample pressure
VACUUM_PRESSURE ₆	1	Vacuum pressure
PURGE_PRESSURE ^{9,10}	1	Purge pressure
CO_MEASURE	2	Detector measure reading
CO_REFERENCE	3	Detector reference reading

SIGNAL NAME	BIT OR CHANNEL NUMBER	DESCRIPTION
	4	Temperature MUX
SAMPLE_FLOW	5	Sample flow
PHOTO_TEMP	6	Photometer detector temperature
TEST_INPUT_7	7	Diagnostic test input
TEST_INPUT_8	8	Diagnostic test input
REF_4096_MV	9	4.096V reference from MAX6241
O2_SENSOR ⁵	10	O ₂ concentration sensor
	11	Spare
CO2_SENSOR ⁷	12	CO ₂ concentration sensor
	13	Spare
	14	DAC loopback MUX
REF_GND	15	Ground reference
Rear board temperature MUX analog inputs		
BOX_TEMP	0	Internal box temperature
SAMPLE_TEMP	1	Sample temperature
BENCH_TEMP	2	Optical bench temperature
WHEEL_TEMP	3	Wheel temperature
TEMP_INPUT_4	4	Diagnostic temperature input
TEMP_INPUT_5	5	Diagnostic temperature input
O2_CELL_TEMP	6	O ₂ sensor cell temperature
	7	Spare
Rear board DAC MUX analog inputs		
DAC_CHAN_0	0	DAC channel 0 loopback
DAC_CHAN_1	1	DAC channel 1 loopback
DAC_CHAN_2	2	DAC channel 2 loopback
DAC_CHAN_3	3	DAC channel 3 loopback
Rear board analog outputs		
CONC_OUT_1	0	Concentration output #1
CONC_OUT_2	1	Concentration output #2
TEST_OUTPUT	2	Test measurement output
CONC_OUT_3 ⁷	3	Concentration output #3 (CO ₂)
¹	Hessen protocol.	
²	M300EH.	
³	M300ES.	
⁴	M320E.	
⁵	O ₂ option.	
⁶	Sample pressure or differential pressure flow measurement option.	
⁷	M306E.	
⁸	Factory option enables concentration alarms on relay outputs.	
⁹	M360E.	
¹⁰	GFC7000E.	

APPENDIX A-5: M360E iDAS Parameters Revision G.4

Table A-5: M360E DAS Trigger Events, Revision G.4

NAME	DESCRIPTION
ATIMER	Automatic timer expired
EXITZR	Exit zero calibration mode
EXITSP	Exit span calibration mode
EXITMP	Exit multi-point calibration mode
SLPCHG	Slope and offset recalculated
EXITDG	Exit diagnostic mode
SOURCW	Source warning
CONCW1	Concentration limit 1 exceeded
CONCW2	Concentration limit 2 exceeded
SYNCW	Sync warning
BNTMPW	Bench temperature warning
WTEMPW	Wheel temperature warning
STEMPW	Sample temperature warning
SFLOWW	Sample flow warning
SPRESW	Sample pressure warning
BTEMPW	Box temperature warning
PTEMPW	Photometer detector temperature warning

Table A-6: M360E iDAS Functions, Revision G.4

NAME	DESCRIPTION	UNITS
DETMES	Detector measure reading	mV
DETRF	Detector reference reading	mV
RATIO	M/R ratio.	None
SLOPE1	Slope for range #1	None
SLOPE2	Slope for range #2	None
OFSET1	Offset for range #1	None
OFSET2	Offset for range #2	None
ZSCNC1	Concentration for range #1 during zero/span calibration, just before computing new slope and offset	PPM
ZSCNC2	Concentration for range #2 during zero/span calibration, just before computing new slope and offset	PPM
CONC1	Concentration for range #1	PPM
CONC2	Concentration for range #2	PPM
STABIL	Concentration stability	PPM
BNTEMP	Bench temperature	°C
WTEMP	Wheel temperature	°C
SMPTMP	Sample temperature	°C
SMPFLW	Sample flow	cc/m
SMPPRS	Sample pressure	"Hg
BOXTMP	Internal box temperature	°C
PHTDRV	Photometer detector temperature drive	mV
TEST7	Diagnostic test input (TEST_INPUT_7)	mV
TEST8	Diagnostic test input (TEST_INPUT_8)	mV
TEMP4	Diagnostic temperature input (TEMP_INPUT_4)	°C
TEMP5	Diagnostic temperature input (TEMP_INPUT_5)	°C
REFGND	Ground reference (REF_GND)	mV
RF4096	4096 mV reference (REF_4096_MV)	mV
BNCDTY	Bench temperature control duty cycle	Fraction 0 = off, 1 = on
WHLDTY	Wheel temperature control duty cycle	Fraction

APPENDIX A-6: Terminal Command Designators, Revision G.4

Table A-7: Terminal Command Designators, Revision G.4

COMMAND	ADDITIONAL COMMAND SYNTAX	DESCRIPTION
? [ID]		Display help screen and commands list
LOGON [ID]	password	Establish connection to instrument
LOGOFF [ID]		Terminate connection to instrument
T [ID]	SET ALL name hexmask	Display test(s)
	LIST [ALL name hexmask] [NAMES HEX]	Print test(s) to screen
	name	Print single test
	CLEAR ALL name hexmask	Disable test(s)
W [ID]	SET ALL name hexmask	Display warning(s)
	LIST [ALL name hexmask] [NAMES HEX]	Print warning(s)
	name	Clear single warning
	CLEAR ALL name hexmask	Clear warning(s)
C [ID]	ZERO LOWSPAN SPAN [1 2]	Enter calibration mode
	ASEQ number	Execute automatic sequence
	COMPUTE ZERO SPAN	Compute new slope/offset
	EXIT	Exit calibration mode
	ABORT	Abort calibration sequence
D [ID]	LIST	Print all I/O signals
	name[=value]	Examine or set I/O signal
	LIST NAMES	Print names of all diagnostic tests
	ENTER name	Execute diagnostic test
	EXIT	Exit diagnostic test
	RESET [DATA] [CONFIG] [exitcode]	Reset instrument
	PRINT ["name"] [SCRIPT]	Print iDAS configuration
	RECORDS ["name"]	Print number of iDAS records
	REPORT ["name"] [RECORDS=number] [FROM=<start date>][TO=<end date>][VERBOSE COMPACT HEX] (Print DAS records)(date format: MM/DD/YYYY(or YY) [HH:MM:SS])	Print iDAS records
CANCEL	Halt printing iDAS records	
V [ID]	LIST	Print setup variables
	name[=value [warn_low [warn_high]]]	Modify variable
	name="value"	Modify enumerated variable
	CONFIG	Print instrument configuration
	MAINT ON OFF	Enter/exit maintenance mode
	MODE	Print current instrument mode
	DASBEGIN [<data channel definitions>] DASEND	Upload iDAS configuration
	CHANNELBEGIN propertylist CHANNELEND	Upload single iDAS channel
	CHANNELDELETE ["name"]	Delete iDAS channels

The command syntax follows the command type, separated by a space character. Strings in [brackets] are optional designators. The following key assignments also apply.

Table A-8: Terminal Key Assignments, Revision G.4

TERMINAL KEY ASSIGNMENTS	
ESC	Abort line
CR (ENTER)	Execute command
Ctrl-C	Switch to computer mode
COMPUTER MODE KEY ASSIGNMENTS	
LF (line feed)	Execute command
Ctrl-T	Switch to terminal mode

USER NOTES:

USER NOTES:

APPENDIX B - M360E Spare Parts List

NOTE

Use of replacement parts other than those supplied by API may result in non-compliance with European standard EN 61010-1.

- 05390 - M360E Spare Parts List
- 04411 - M360E Recommended Spare Parts Stocking Levels

M360E Spare Parts List

Part Number	Description
000941000	ORIFICE, 13 MIL (SAMPLE FLOW)
001760400	ASSY, FLOW CTL, 800CC, 1/4" CONN-B
001761300	ASSY, SPAN GAS FLOW CONTROL
003290500	ASSY, THERMISTOR, M300 BENCH
003291500	ASSY, THERMISTOR, BENCH/WHEEL, M300E
006110200	ASSY, M300 MOTOR WHEEL HEATER
006900000	PAD, SCRUBBER RETAINER
009450300	ASSY, ZERO/SPAN VALVES, M300E (KB)
009550500	ASSY, SOURCE, M300E S/N>65
009560201	FILTER WHEEL, CO2
009600400	AKIT, EXPENDABLES, M300E
009690000	AKIT, TFE FLTR ELEM, 47MM, (FL6) (100)
009690100	AKIT, TFE FLTR, 47MM, (FL6) (30)
009840300	ASSY, SHUT-OFF VALVE, M300E (KB)
010790000	INPUT MIRROR, REPLICATED
010800000	OUTPUT MIRROR, REPLICATED
016290000	WINDOW, SAMPLE FILTER, 47MM (KB)
016300600	ASSY, SAMPLE FILTER, 47MM, ANG BKT, 5UM
019340200	ASSY, SAMPLE THERMISTOR, M300 BRASS
026060000	MIRROR, OBJECTIVE, 8 PASS,360E,320E,300E
026070000	MIRROR, FIELD, 8 PASS
035280000	ASSY, SCRUBBER, CO2, CH47, M360
036110300	PCA, SYNC DEMOD w/DETECTOR, M360E
037250100	ASSY, HEATER, OPTICAL BENCH
037600000	KIT, EXPENDABLE, CO2 SCRUBBER
037860000	ORING, TFE RETAINER, SAMPLE FILTER
040010000	ASSY, FAN REAR PANEL, E SERIES
040030100	PCA, FLOW/PRESSURE
041350000	PCA, RELAY BOARD, M300E
041710000	ASSY, CPU, CONFIGURATION, "E" SERIES
042410100	ASSY, PUMP W/FLOW CONTROL
042410200	ASSY, PUMP, INT, E SERIES
042580000	PCA, KEYBOARD, E-SERIES, W/V-DETECT
042680000	ASSY, VALVE, FOR SAMPLE/CAL VALVE ASSY
042690000	ASSY, VALVE , SHUT-OFF
042890100	ASSY, PUMP CONFIG PLUG, 100-115V/60 HZ
042900100	PROGRAMMED FLASH, E SERIES
043250100	ASSY, PWR CONF, 100-120V/60HZ, M3XXEX
043250300	OPTION, PWR CONF, 220-240V/50HZ, M3XXEX
043250400	OPTION, PWR CONF, 220-240V/60HZ, M3XXEX
043940000	PCA, INTERFACE, ETHERNET, E-SERIES
045830000	ASSY, CO2 SENSOR, M360E
045840000	MANUAL, OPERATORS, M360E
045930000	ASSY, PURGE REGULATOR, M360E
048620200	PCA, SERIAL INTERFACE, w/ MD, E SERIES
050110000	THERMAL PAD, DETECTOR HEATSINK

M360E Spare Parts List

Part Number	Description
050320000	PCA, OPTO-INTERRUPTER, M300E
052560000	PCA, OPTO-INTERRUPTER, M360EX/GFC7000E
052830200	ASSY, MOTOR HUB, MR7, "E", 115V
053220100	DOC, w/SOFTWARE, M360E
053230000	AKIT, EXPENDABLES, M360E IZS (w OPT 42C)
055010000	ASSY, MTR WHL HEATER w/THERM, 200W
055100200	OPTION, PUMP ASSY, 240V *
058021100	PCA, E-SERIES MOTHERBOARD, GEN 5-I
CN0000458	CONNECTOR, REAR PANEL, 12 PIN
CN0000520	CONNECTOR, REAR PANEL, 10 PIN
DS0000025	DISPLAY, E SERIES (KB)
FL0000001	FILTER, SS
FL0000003	FILTER, DFU
FM0000004	FLOWMETER (KB)
HW0000020	SPRING
HW0000036	TFE TAPE, 1/4" (48 FT/ROLL)
HW0000090	SPRING, PURGE ORIFICE
HW0000101	ISOLATOR
HW0000379	SEAL, PURGED MOTOR ASSY
KIT000219	KIT, 4-20MA CURRENT OUTPUT (E SERIES)
OP0000009	WINDOW, IR SOURCE
OR0000001	ORING, FLOW CONTROL
OR0000002	ORING, WHEEL HOUSING SEAL
OR0000025	ORING, CO2 SCRUBBER
OR0000034	ORING, INPUT & OUTPUT MIRRORS
OR0000039	ORING, IR SOURCE/BENCH
OR0000041	ORING, OBJECT & FIELD MIRRORS
OR0000047	ORING, WHEEL HOUSING SEAL
OR0000077	ORING, 2-018V
OR0000088	ORING, DETECTOR
OR0000094	ORING, SAMPLE FILTER
OR0000096	ORING, WHEEL HOUSING SEAL
OR0000097	ORING, PURGED MOTOR ASSY
PS0000011	PWR SUPPLY, SW, +5V, +/-15V, 40W (KB)
PS0000024	POWER SUPPLY COVER
PS0000025	PWR SUPPLY, SW, 12V, 40W (KB)
PU0000022	REBUILD KIT, FOR PU20 & 04241 (KB)
RL0000015	RELAY, DPDT, (KB)
SW0000051	SWITCH, POWER CIRC BREAK VDE/CE, w/RG(KB)
SW0000059	PRESSURE SENSOR, 0-15 PSIA, ALL SEN
VA0000014	REGULATOR
WR0000008	POWER CORD, 10A, 6'

Recommended Spare Parts Stocking Levels Model 360E

Recommended Spare Parts Stocking Level: Standard

Part Number	Description	Units				
		1	2-5	6-10	11-20	21-30
003290500	ASSY, THERMISTOR, M300 BENCH	1	1	1	1	2
009550500	ASSY, SOURCE, M300E S/N>65	1	1	2	2	3
037250100	ASSY, BAND HEATER W/TC, M300EM/M3X0E		1	1	2	2
040010000	ASSY, FAN REAR PANEL, E SERIES		1	1	2	2
040030100	PCA, PRESS SENSORS (1X), w/FM4, E SERIES			1	2	3
041710000	ASSY, CPU, CONFIGURATION, "E" SERIES			1	2	2
042410200 *	ASSY, PUMP, INT, SOX/O3/IR			1	2	3
042580000	PCA, KEYBOARD, E-SERIES, W/V-DETECT				1	1
052560000	PCA, OPTO-INTERRUPTER, M360EX/GFC7000E				1	2
052840200	ASSY, MOTOR HUB, MR7, PURGED, "E", 115V			1	2	3
055010000	ASSY, MTR WHL HEATER w/THERM, 200W				1	1
058021100	PCA, E-SERIES MOTHERBOARD, GEN 5-I				1	2
DS0000025	DISPLAY, E SERIES (KB)				1	1
KIT000159	REPLACEMENT, RELAY BD, M300E, SN >= 100				1	1
KIT000180	RETROFIT, SYNC DMOD UPDATE, M360E				1	1
KIT000183	REPLACE, CO2 FILTER WHEEL ASSY, E-SERIES				1	1
PS0000011	PWR SUPPLY, SW, +5V, +/-15V, 40W (KB)			1	2	2
PS0000025	PWR SUPPLY, SW, 12V, 40W (KB)			1	2	2
RL0000015	RELAY, DPDT, (KB)		1	1	2	2

* Recommended Spare Parts Stocking Level: For Pump Assembly, 240V Option Installed

Part Number	Description	Units				
		1	2-5	6-10	11-20	21-30
055100200	OPTION, PUMP ASSY, 240V			1	2	2

Recommended Spare Parts Stocking Level: For IZS or ZS Option Installed

Part Number	Description	Units				
		1	2-5	6-10	11-20	21-30
042680000	ASSY, VALVE (SS), M300E				1	2
042690000	ASSY, VALVE , 2-WAY, 12V				1	2

THIS PAGE IS INTENTIONALLY LEFT BLANK

CUSTOMER: _____ PHONE: _____

CONTACT NAME: _____ FAX NO: _____

SITE ADDRESS: _____

SERIAL NO.: _____ FIRMWARE REVISION: _____

1. Are there any failure messages? _____

Please complete the following table:

PARAMETER	DISPLAYED AS	OBSERVED VALUE	UNITS	NOMINAL RANGE
Range			PPM	0 -10, 0 - 2000 Ppm
Stability	STABIL		PPM	≤ 0.15 Ppm With Zero Air
CO ₂ Measure	CO2 MEAS		mV	3600 – 4800 Mv
CO ₂ Reference	CO2 REF		mV	1400 – 2000 Mv
Measure/Reference Ratio	MR RATIO			2.5 ± 0.02 W/ Zero Air
Pressure	PRES		INHG	-2" Ambient Absolute
Sample Flow	SAMP FL		CC	800 ± 10%
Sample Temp	SAMPLE TEMP		°C	48 ± 4
Bench Temp	BENCH TEMP		°C	48 ± 2
Wheel Temp	WHEEL TEMP		°C	68 ± 2
Box Temp	BOX TEMP		°C	Ambient + 7 ± 10
Photo Drive	PHT DRIVE		mV	250 Mv TO 4750 Mv
Slope	SLOPE			1.0 ± .3
Offset	OFFSET			0 ± 0.3
O ₂ Sensor Temperature ³	O2 CELL TEMP			
Slope of O ₂ Measurement ³	O2 SLOPE			
Offset of O ₂ Measurement ³	O2 OFFSET			
Dark Cal Reference signal	REF DARK OFFSET		mV	125 ± 50 Mv.
Dark Cal Measurement Signal	MEAS DARK OFFSET		mV	125 ± 50 Mv
Electric Test			PPM	40 ± 2 Ppm
Values are in the Signal I/O				
REF_4096_MV				4096mv±2mv And Must Be Stable
REF_GND				0± 0.5 And Must Be Stable

2. Have you performed a leak check and flow check? _____

3. What is the sample flow & sample pressure with the sample in-let on rear of machine capped?

SAMPLE FLOW _____ **CC** **SAMPLE PRESSURE** _____ **IN-HG-A**

TELEDYNE API CUSTOMER SERVICE

EMAIL: api-customerservice@teledyne.com

PHONE: (858) 657-9800 - TOLL FREE: (800) 324-5190 - FAX: (858) 657-9816

3. What are the failure symptoms? _____

4. What test have you done trying to solve the problem? _____

5. Please check these signals and verify the correctness. Look for the signals annotated on the diagram. What are the peak-to-peak voltages?

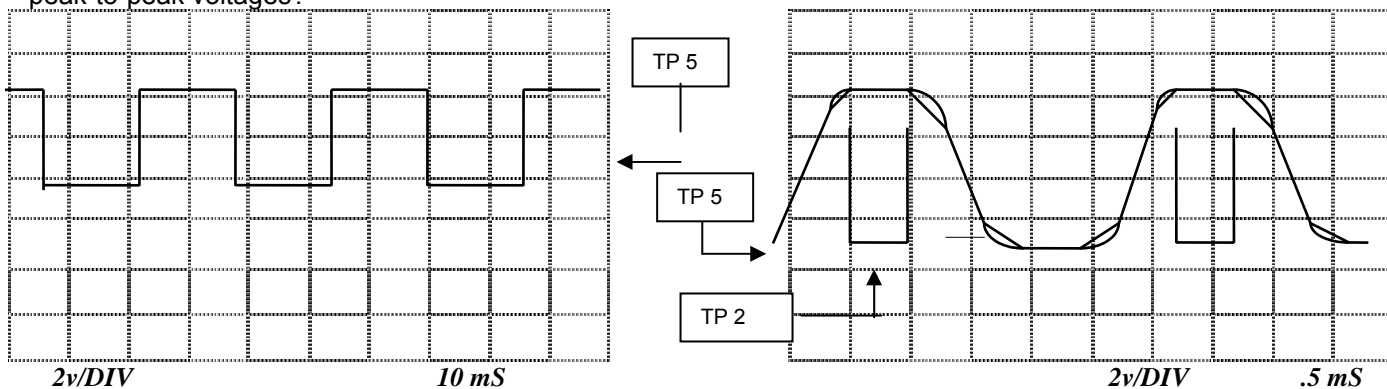

5. If possible, please include a portion of a strip chart pertaining to the problem. Circle pertinent data.

THANK YOU FOR PROVIDING THIS INFORMATION. YOUR ASSISTANCE ENABLES TELEDYNE API TO RESPOND FASTER TO THE PROBLEM THAT YOU ARE ENCOUNTERING.

OTHER INFORMATION: _____

APPENDIX D - ELECTRONIC SCHEMATICS

Table D-1: List of Included Electronic Schematics

DOCUMENT #	DOCUMENT TITLE
03297	PCA, 03296, IR Photodetector Preamp and Sync Demodulator
03632	PCA, 03631, 0-20mA driver
03976	PCA, 03975, Keyboard & Display Driver
04003	PCA, 04003, Pressure/Flow Transducer Interface
05703	PCA, 05702, Motherboard, E-Series Gen 4
04089	PCA, 04088, Opto Pickup Interface
04136	PCA, 04135 Rev A, M300E Relay
04216	Interconnect Drawing - M300E SNs >=100
04217	Interconnect List - M300E SNs >=100
04259	PCA, 04258, Keyboard & Display Driver
04468	PCA, 04467, Analog Output Series Res

User Notes:

Free Manuals Download Website

<http://myh66.com>

<http://usermanuals.us>

<http://www.somanuals.com>

<http://www.4manuals.cc>

<http://www.manual-lib.com>

<http://www.404manual.com>

<http://www.luxmanual.com>

<http://aubethermostatmanual.com>

Golf course search by state

<http://golfingnear.com>

Email search by domain

<http://emailbydomain.com>

Auto manuals search

<http://auto.somanuals.com>

TV manuals search

<http://tv.somanuals.com>