

**ADDENDUM TO  
MODEL 101E  
OPERATORS MANUAL  
(P/N 04740 REV. A)**

**FOR**

**MODEL 102E  
TOTAL REDUCED SULFUR ANALYZER  
with  
MODEL 501 TRS  
THERMAL CONVERTER**

© TELEDYNE ADVANCED POLLUTION INSTRUMENTATION  
9480 CARROLL PARK DRIVE  
SAN DIEGO, CA 92121-5201  
USA

Toll-free Phone: 800-324-5190  
Phone: 858-657-9800  
Fax: 858-657-9816  
Email: [Api-sales@teledyne.com](mailto:Api-sales@teledyne.com)  
Website: <http://www.teledyne-api.com/>



# TABLE OF CONTENTS

<b>1. PREFACE</b> .....	<b>1</b>
1.1. Reference Numbering convention.....	2
<b>2. SPECIFICATIONS, APPROVALS AND WARRANTY</b> .....	<b>3</b>
2.1. Specifications.....	3
2.1.1. M501-TRS Specifications .....	3
2.2. EPA Equivalency Designation.....	3
2.3. CE Mark Compliance .....	4
<b>3. GETTING STARTED</b> .....	<b>5</b>
3.1. Unpacking the M102E .....	5
3.2. Unpacking the M501-TRS .....	5
3.2.1. M501-TRS Ventilation Clearance: .....	6
3.3. Internal Layouts.....	7
3.4. Internal Pneumatic Flow of the M102E & the M501-TRS .....	8
3.5. Rear Panel Layout for the M102E & M501-TRS .....	9
3.6. Initial Setup .....	10
3.6.1. Electrical Connections: .....	10
3.6.1.1. M102E Analog Output Connections .....	10
3.6.1.2. M501-TRS Alarm Output Connections .....	11
3.6.2. Pneumatic Connections: .....	11
3.6.2.1. Connections with Internal Valve Options Installed.....	14
3.7. Initial Operation .....	17
3.7.1. Startup / Warm Up of the M102E.....	17
3.7.2. Functional Check of the M102E.....	17
3.7.3. Startup / Warm Up of the M501-TRS.....	18
3.8. Initial Calibration.....	19
<b>4. OPTIONAL HARDWARE AND SOFTWARE</b> .....	<b>21</b>
4.1. Rack Mount Kits (Options 20a, 20b, 21, 22 & 81).....	21
4.2. Calibration Valves Options .....	21
4.2.1. Zero/Span Valves (Option 50) & Internal Zero/Span Gas Generator (Option 51).....	21
4.3. Additional Manuals.....	24
4.3.1. Printed Manuals (P/N 049880000) .....	24
4.3.2. Addendum on CD (Part number 049880200).....	24
<b>5. M102E OPERATING INSTRUCTIONS</b> .....	<b>25</b>
5.1.1. M102E Analog Output Signals .....	25
5.1.2. Setting the M102E Gas Measurement Mode.....	26
5.2. SETUP – DIAG: Using the Diagnostics Functions.....	26
5.2.1. M102E Analog I/O Configuration.....	26
5.2.2. M102E Test Channel Output .....	27
5.3. SETUP – COMM: Setting Up the M102E’s Communication Ports .....	27
5.3.1. M102E ID Code.....	27
5.3.2. M102E Ethernet Host Name.....	27
5.4. Remote Operation of the Analyzer.....	28
5.4.1. Control Inputs .....	28
5.4.2. Using the M102E with a Hessen Protocol Network .....	29
5.4.2.1. M102E Hessen Protocol Gas ID List. ....	29
5.4.2.2. Setting Hessen Protocol Status Flags .....	30
<b>6. M501-TRS OPERATING INSTRUCTIONS</b> .....	<b>31</b>
6.1. Basic M501-TRS Controls.....	31
6.2. To Display The Current Temperature: .....	32
6.3. To Manually Adjust the Converter Oven Temperature: .....	33
6.4. Autotune the Temperature Controller: .....	34
6.4.1. Initiating the Autotune Process: .....	34
6.4.2. Aborting the Autotune Process: .....	35
6.5. M501TRS Alarm Relay Adjustment .....	35
<b>7. CALIBRATION PROCEDURES</b> .....	<b>37</b>
7.1. M102E Calibration .....	37
7.2. M501-TRS Calibration .....	37

<b>8. INSTRUMENT MAINTENANCE</b> .....	<b>39</b>
8.1. Additional and Updated Maintenance Procedures .....	40
8.1.1. Maintaining the SO <sub>2</sub> Scrubber .....	40
8.1.1.1. Predicting When the SO <sub>2</sub> Scrubber Should Be Replaced. ....	40
8.1.1.2. Checking the Function of the SO <sub>2</sub> Scrubber.....	41
8.1.1.3. Changing the SO <sub>2</sub> Scrubber Material .....	41
<b>9. THEORY OF OPERATION</b> .....	<b>43</b>
9.1. Measurement Principle .....	43
9.1.1. TRS Conversion .....	43
9.1.2. SO <sub>2</sub> Ultraviolet Fluorescence .....	43
9.2. The UV Light Path.....	46
9.2.1. UV Lamp Shutter & PMT Offset.....	46
9.3. Pneumatic Operation.....	46
9.3.1. Sample gas Flow .....	46
9.3.2. M501 SO <sub>2</sub> Scrubber .....	46
9.4. Electronic Operation.....	47
9.4.1. Sensor Module.....	47
9.4.1.1. Sample Chamber .....	48
9.4.1.2. Sample Chamber Heating Circuit.....	48
9.4.2. M501-TRS electronics .....	49
9.4.2.1. Thermal Switch .....	49
9.4.2.2. Temperature Alarms and Alarm Output .....	50
<b>10. TROUBLESHOOTING &amp; REPAIR</b> .....	<b>51</b>
10.1.1. Fault Diagnosis with Warning Messages .....	51
10.1.1.1. M102E Warning Messages .....	51
10.1.1.2. M501-TRS Error Codes.....	51
10.1.2. Fault Diagnosis with Test Functions.....	52
10.2. M501-TRS Trouble shooting .....	53
10.2.1. TRS Converter Not Heating:.....	53
10.3. Other Performance Problems .....	53
10.3.1. Excessive noise .....	53
10.4. Subsystem Checkout.....	54
10.4.1. Checking the Efficiency of the M501-TRS SO <sub>2</sub> Scrubber.....	54
10.4.2. Checking the Efficiency of the M501-TRS TRS → SO <sub>2</sub> Converter.....	54
10.5. Additional Repair Procedures .....	55
10.5.1. UV Lamp Adjustment and/or Replacement .....	55
10.5.1.1. Adjusting the UV Lamp ( <i>Peaking the Lamp</i> ) .....	56
10.5.1.2. Replacing the UV Lamp .....	57
10.5.2. Replacing the UV filter/lens .....	58
10.5.3. Replacing the PMT, HVPS or TEC.....	59
10.5.4. M102E PMT Hardware Calibration ( <i>FACTORY CAL</i> ) .....	61
10.5.5. Replacing the TRS Converter Heating Tube .....	63
10.6. Manually Programming the M501-TRS Temperature Controller .....	64
10.6.1. Temperature Controller Primary Menu Parameters.....	65
10.7. Technical Assistance .....	67

## LIST OF APPENDICES

### APPENDIX A - VERSION SPECIFIC SOFTWARE DOCUMENTATION

- APPENDIX A-1: M102E Software Menu Trees, Revision A.2
- APPENDIX A-2: Setup Variables For Serial I/O, Revision A.2
- APPENDIX A-3: Warnings and Test Functions, Revision A.2
- APPENDIX A-4: M102E Signal I/O Definitions, Revision A.2
- APPENDIX A-5: M102E iDAS Functions, Revision A.2

### APPENDIX B - M102E SPARE PARTS LIST

### APPENDIX D - ELECTRONIC SCHEMATICS

## LIST OF FIGURES

Figure 3-1:	M102E Internal Layout .....	7
Figure 3-2:	M501-TRS Internal Layout.....	7
Figure 3-3:	Internal Pneumatic Diagram of the M102E Standard Configuration.....	8
Figure 3-4:	M102E Rear Panel Layout.....	9
Figure 3-5:	M501-TRS Rear Panel Layout.....	9
Figure 3-6:	Analog Output Connector .....	10
Figure 3-7:	Pneumatic Connections–Basic Configuration–Using Gas Dilution Calibrator .....	12
Figure 3-8:	Pneumatic Connections–Basic Configuration–Using Bottled Span Gas .....	12
Figure 3-9:	Basic Pneumatic Connections for Units with Zero/Span Valve Option .....	15
Figure 3-10:	Pneumatic Connections for Formal Calibration of Units with an IZS Valve Option ...	16
Figure 3-11:	Pneumatic Connections for Informal Calibration Checks of Units with IZS Valve Option .....	16
Figure 3-12:	M501-TRS Temperature Controller Startup .....	18
Figure 4-1:	Internal Pneumatic Diagram of the M102E With Z/S Option Installed.....	22
Figure 4-2:	Internal Pneumatic Diagram of the M102E with IZS Options Installed.....	23
Figure 5-1:	Analog Output Connector Key .....	25
Figure 5-2:	Control Inputs with local 5 V power supply .....	28
Figure 5-3:	Control Inputs with external 5 V power supply .....	29
Figure 6-1:	M501-TRS Temperature Controls .....	31
Figure 9-1:	UV Absorption in the M102E Reaction Cell .....	44
Figure 9-2:	M102E Sensor Module .....	47
Figure 9-3:	M102E Sample Chamber.....	48
Figure 9-4:	M501-TRS Electronic Block Diagram .....	49
Figure 10-1:	Shutter Assembly - Exploded View.....	57
Figure 10-2:	Disassembling the Shutter Assembly.....	58
Figure 10-3:	PMT Assembly - Exploded View .....	59
Figure 10-4:	Pre-Amplifier Board Layout.....	62

## LIST OF TABLES

Table 2-1:	Model 102E Basic Unit Specifications.....	3
Table 3-1:	TRS – SO <sub>2</sub> Switching Valve Operating Modes.....	8
Table 3-2:	Analog output Pin Outs.....	10
Table 3-3:	Inlet / Outlet Connector Nomenclature .....	11
Table 3-4:	NIST-SRM's Available for Traceability of H <sub>2</sub> S & SO <sub>2</sub> Calibration Gases .....	14
Table 4-1:	Zero/Span Valve Operating States.....	22
Table 4-2:	IZS Valve Operating States .....	23
Table 5-1:	M102E gas Measurement Modes.....	26
Table 5-2:	Analog Output Pin Assignments.....	26
Table 5-3:	Test Parameters Available for Analog Output A4 .....	27
Table 5-4:	M102E Control Input Pin Assignments .....	28
Table 5-5:	M102E Default Hessen Gas ID's.....	29
Table 5-6:	Default Hessen Status Bit Assignments .....	30
Table 6-1:	M501-TRS Temperature Controls and Definitions .....	32
Table 8-1:	M102E Preventive Maintenance Schedule.....	39
Table 10-1:	Test Functions - Possible Causes for Out-Of-Range Values .....	51
Table 10-2:	Test Functions - Possible Causes for Out-Of-Range Values .....	52
Table 10-3:	Temperature Controller – Primary Parameter Settings.....	66
Table 10-4:	Temperature Controller – Primary Parameter Settings.....	67



# 1. PREFACE

## NOTE

The information contained in this addendum is pertinent to M102E analyzers running software revision A.2. Some or all of the information may not be applicable to previous revision of that software.

The software revision your analyzer is running is displayed in the upper left-hand corner of the display any time the instrument is in SETUP mode.

This addendum is based on the Model 101E Operators Manual (P/N 04740, REV. A). In most ways the M102E is identical to the M101E in design and operation, therefore most of the basic set up information, operating instructions as well as calibration, maintenance, troubleshooting and repair methods are found in that manual.

This addendum documents only those areas where the M102E is different in design or operating method from the M101E.

Specifically:

- Areas where updates and improvements to the M10XE software have been implemented since the publication date of the M101E Manual - P/N 04740 Rev A.
- Corrections of errors and omissions discovered in the M101E Manual - P/N 04740 Rev A.
- **EXTERNAL TRS CONVERSION:** Like the M101E, which converts H<sub>2</sub>S to SO<sub>2</sub>, then measures the amount of SO<sub>2</sub> present using a UV fluorescence technique, the M102E converts total reduced sulfur (TRS) gases into SO<sub>2</sub> before measuring the SO<sub>2</sub> using the same UV fluorescence method.

Unlike the M102E, which performs the H<sub>2</sub>S → SO<sub>2</sub> conversion internally, the M101E requires an external TRS converter, in this case a Teledyne Instruments M501-TRS.

Therefore this addendum includes instructions and information regarding:

- Areas of operation and setup of the M102 that depart from the method described by the M101E operator's manual because the TRS → SO<sub>2</sub> conversion is performed externally.
- The proper set up and operation on the M501-TRS.

## 1.1. Reference Numbering convention

Unless otherwise specified, chapter, section, figure and table reference numbers referred to within this text are relative to this document.

EXAMPLE: "Figure 2-1" refers to the figure, within this document, labeled as 2-1.

References to chapters, sections, figures and tables in the original document will be labeled as such.

EXAMPLE: "Figure 6.1 of the M101E Operators Manual (P/N 04470, REV. A)".

---

## User Notes:



## 2. SPECIFICATIONS, APPROVALS AND WARRANTY

### 2.1. Specifications

There are no significant differences between the performance specifications for the M102E and the M102E as listed in Section 2.1 of the M101E Manual - P/N 04740 Rev A.

#### 2.1.1. M501-TRS Specifications

**Table 2-1: Model 102E Basic Unit Specifications**

Minimum Converter Efficiency	H <sub>2</sub> S >95% COS >90% CS <sub>2</sub> >90%
Maximum TS Concentration for specified conversion efficiency	20 ppmv
Sample Flow Rate	650cc/min. ±10% - driven by M102E pneumatic system
Optimum Converter Temperature	1000°C (factory setup)
Maximum Converter Temperature	1100°C
Dimensions H x W x D	7" x 17" x 22" (178 mm x 432 mm x 559 mm)
Weight	16 lbs (8 kg) 26 lbs (12 kg) CE version
AC Power Rating	115 V, 50/60 Hz - 400 Watts; 230 V, 50/60 Hz - 575 Watts; CE Version
Internal Alarms	High Alarm Point: 1050°C Low Alarm Point: 950°C
Alarm Output Relay	SPST - 1 point: Alarm output is energized should either the temperature controller's high or low internal alarm set points be activated.
Alarm Output Rating	220V AC/30V DC, 1A (resistive load)
Environmental	Installation category (over-voltage category) II; Pollution degree 2
Certifications	IEC 1010-1 / 61010-1:93 (includes A1) + A2:95,
For indoor use at altitudes ≤ 2000m only	

### 2.2. EPA Equivalency Designation

No EPA equivalency standards exist for TRS measurement, however, the M102E analyzer qualifies for EPA equivalency designation as Reference Method Number EQSA-0495-100 per 40 CFR Part 53 when operated under the following conditions:

- Measurement Mode: SO<sub>2</sub> single gas mode.
- Range: Any range from 50 parts per billion (ppb) to 10 parts per million (ppm).
- Ambient temperature range of 5 °C to 40 °C.
- Line voltage range of 105-125 VAC or 220-240 VAC, at 50 or 60 Hz.

- Sample filter: Equipped with PTFE filter element in the internal filter assembly.
- Sample flow of 650 +/- 65 cc/min.
- Vacuum pump (internal or external) capable of 14"Hg Absolute pressure @ 1 slpm or better.
- Software settings:

Dynamic span	OFF
Dynamic zero	OFF
Dilution factor	OFF
AutoCal	ON or OFF
Dual range	ON or OFF
Auto-range	ON or OFF
Temp/Pressure compensation	ON

Under the designation, the analyzer may be operated with or without the following optional equipment:

- Rack mount with chassis slides.
- Rack mount without slides, ears only.
- Zero/span valve options.
- Internal zero/span (IZS) option with either:
  - SO<sub>2</sub> permeation tube - 0.4 ppm at 0.7 liter per minute; certified/uncertified.
  - SO<sub>2</sub> permeation tube - 0.8 ppm at 0.7 liter per minute; certified/uncertified. Under the designation, the IZS option cannot be used as the source of calibration.
- 4-20mA isolated analog outputs.
- Status outputs.
- Control inputs.
- RS-232 output.
- Ethernet output.
- Zero air scrubber.
- 4-20mA, isolated output.

## 2.3. CE Mark Compliance

See Section 2.3 of the M101E Manual - P/N 04740 Rev A

---

## User Notes:

## 3. GETTING STARTED

### 3.1. Unpacking the M102E

Unpack the M102E as per the directions ins Section 3.1 of the M101E Manual - P/N 04740 Rev A.

1. There are no shipping screws to be removed in the M102E.

### 3.2. Unpacking the M501-TRS

2. Inspect the shipping package for external damage. If damaged, please advise the shipper first, then Teledyne Instruments.
3. Carefully remove the top cover of the converter and check for internal shipping damage.
  - Remove the screws fastening the top cover to the unit (four per side).
  - Lift the cover straight up.



#### CAUTION

**Never disconnect electronic circuit boards, wiring harnesses or electronic subassemblies while the unit is under power.**

4. Inspect the interior of the instrument to make sure all components are in good shape and properly seated.
5. Check the connectors of the various internal wiring harnesses and pneumatic hoses to make sure they are firmly and properly seated.
6. There are no shipping screws to be removed in the M501-TRS.
7. Replace the top cover.

#### NOTE

**The M501-TRS will not operate properly with the top cover removed.**

**The air cooling required to stabilize the temperature of the converter tube is dependent on air flow patterns that only exist with the top cover in place.**

**Without the top cover in place, the thermal cutout may overheat and shut off the heating element.**

### 3.2.1. M501-TRS Ventilation Clearance:

Whether the M501-TRS is set up on a bench or installed into an instrument rack, be sure to leave sufficient ventilation clearance.

AREA	MINIMUM REQUIRED CLEARANCE
Back of the instrument	10 cm / 4 inches
Sides of the instrument	2.5 cm / 1 inch
Above and below the instrument.	2.5 cm / 1 inch

#### NOTE

**If the M501-TRS is installed in an instrument rack or any type of enclosure, make sure that the rack/enclosure itself is adequately ventilated.**

**Failure to provide proper ventilation can result in the ambient temperature exceeding the maximum operating temperature specification for the M102E (40°C)**

### 3.3. Internal Layouts

Figures 3-1 & 3-3 supersede Figure 3-9 of the M101E Manual - P/N 04740 Rev A.

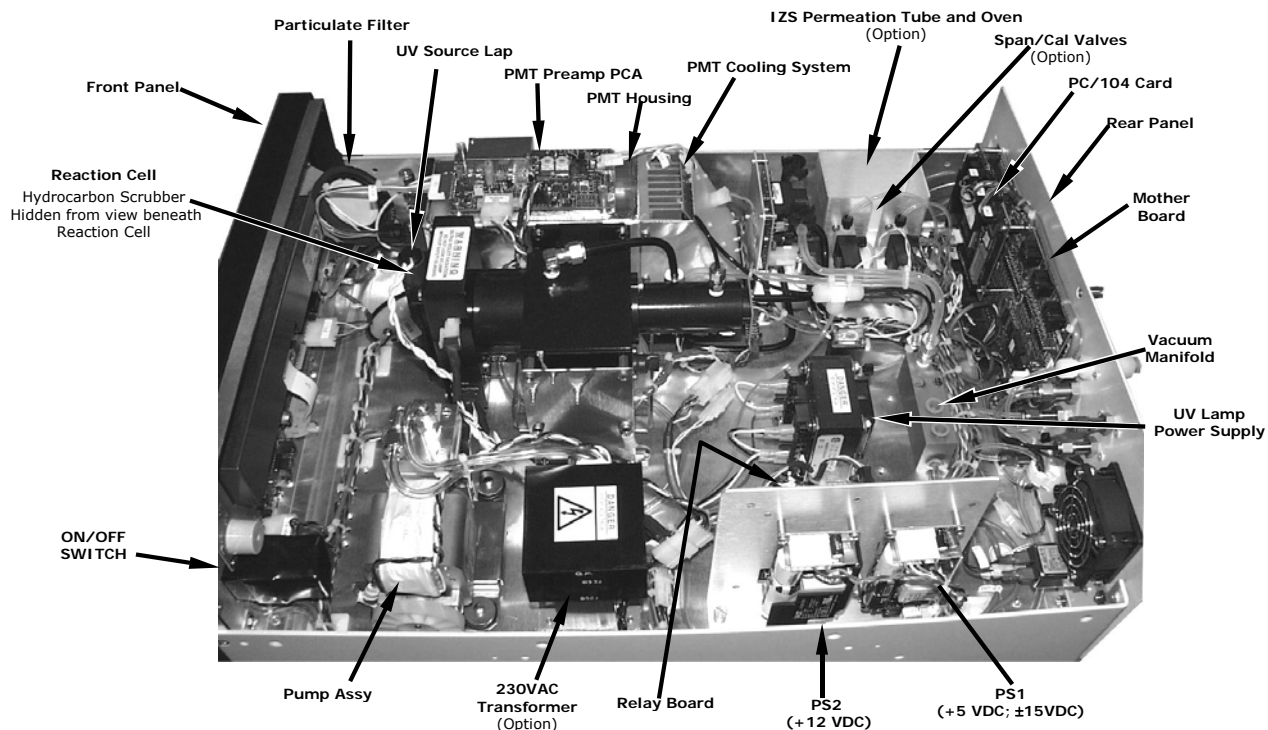

Figure 3-1: M102E Internal Layout

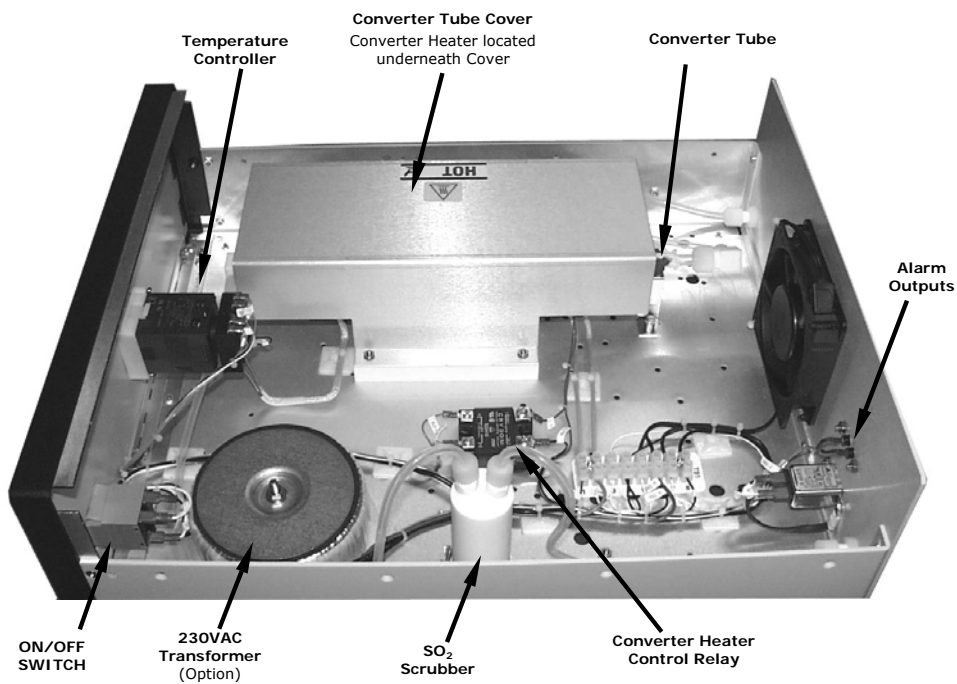

Figure 3-2: M501-TRS Internal Layout

### 3.4. Internal Pneumatic Flow of the M102E & the M501-TRS

Figure 3-3 shows the internal pneumatic flow of the M102E in its Standard configuration. For information on instruments in which one of the various zero/span valve options refer to Figures 5-2 and 5-3.

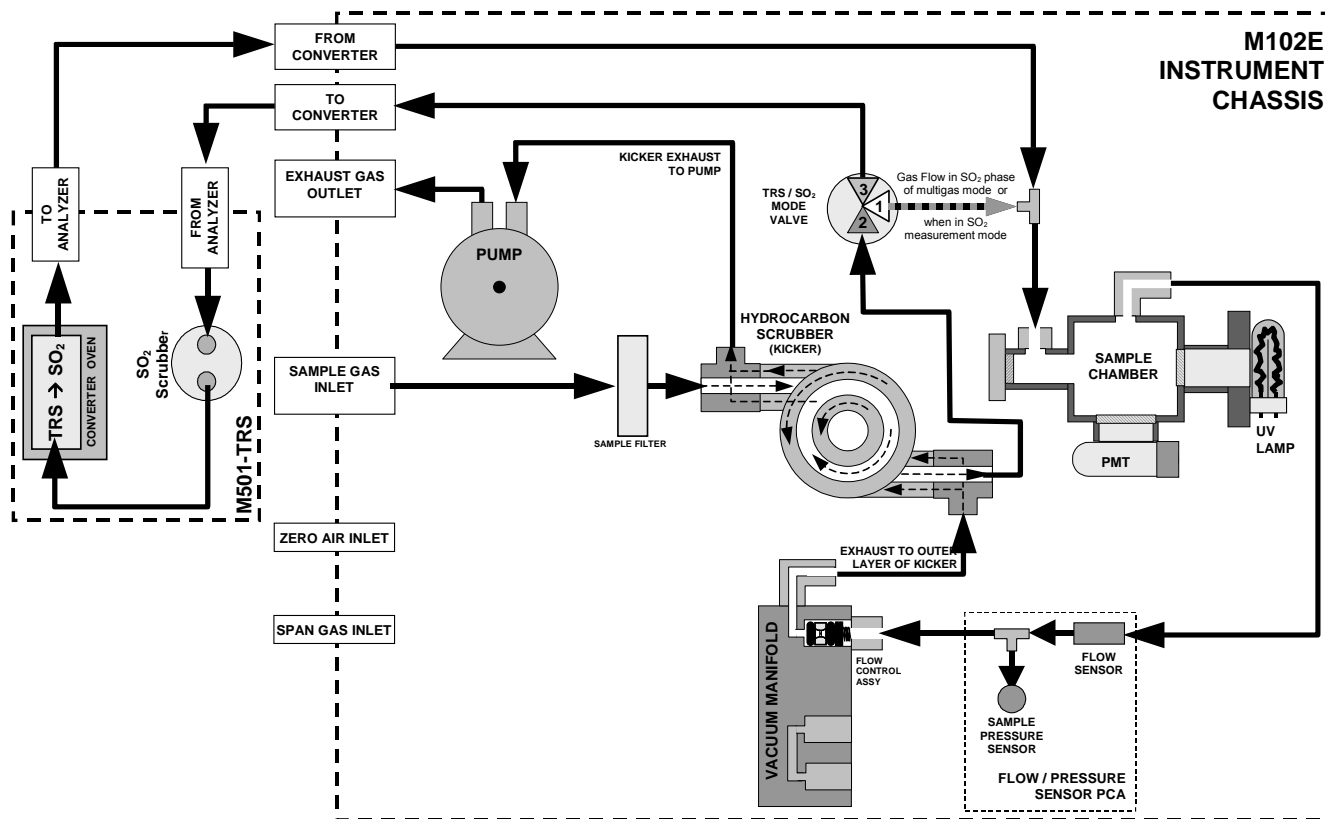

Figure 3-3: Internal Pneumatic Diagram of the M102E Standard Configuration.

Table 3-1: TRS – SO<sub>2</sub> Switching Valve Operating Modes

GAS MODE	CONDITION OF TRS –SO <sub>2</sub> SWITCHING VALVE	VALVE PORT CONNECTION (FIG. 5-2)
TRS	Open to SO <sub>2</sub> Scrubber and Molybdenum Converter	2 → 3
SO <sub>2</sub>	Open to directly to Sample Chamber. Bypasses M501-TRS	2 → 1
TRS –SO <sub>2</sub>	Switches between above two states every 10 minutes.	- -

### 3.5. Rear Panel Layout for the M102E & M501-TRS

Figures 3-4 & 3-5 supersede Figure 3-2 of the M101E Manual - P/N 04740 Rev A.

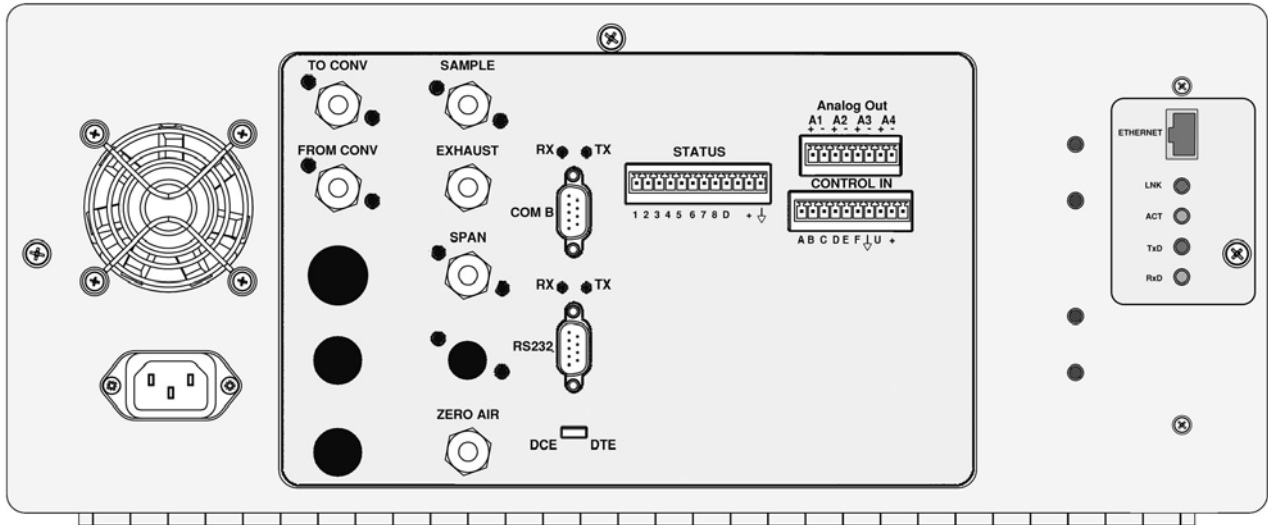

Figure 3-4: M102E Rear Panel Layout

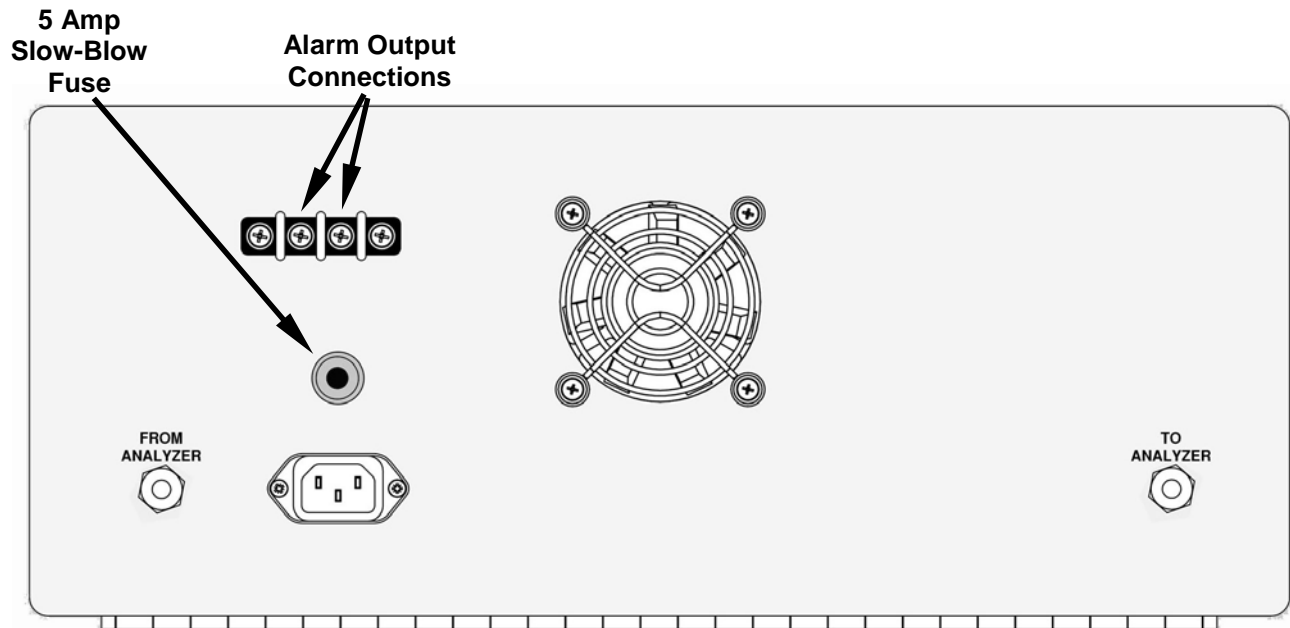

Figure 3-5: M501-TRS Rear Panel Layout

## 3.6. Initial Setup

### 3.6.1. Electrical Connections:

The electrical connections for the M102E are the same as those described in Section 3.1.1 of the M101E Manual - P/N 04740 Rev A except for the test channel analog output:

#### 3.6.1.1. M102E Analog Output Connections

This section supercedes Section 3.1.1.1 of the M101E Manual - P/N 04740 Rev A.

Attach a strip chart recorder and/or data-logger to the appropriate contacts of the analog output connector on the rear panel of the analyzer.

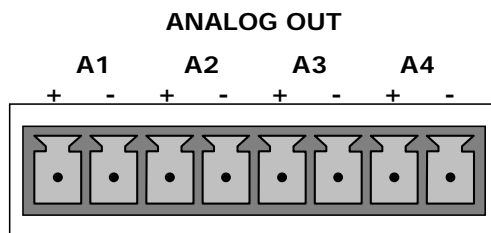

Figure 3-6: Analog Output Connector

The **A1** and **A2** channels output a signal that is proportional to the SO<sub>2</sub> concentration of the sample gas.

The output, labeled **A3** is special. It can be set by the user (see Section 6.9.10 of the M101E Manual - P/N 04740 Rev A) to output any one of the parameters accessible through the <TST TST> keys of the units sample display.

Pin-outs for the Analog Output connector at the rear panel of the instrument are:

Table 3–2: Analog output Pin Outs

PIN	ANALOG OUTPUT	VOLTAGE OUTPUT	CURRENT LOOP OPTION
1	<b>A1</b>	V Out	I Out +
2		Ground	I Out -
3	<b>A2</b>	V Out	I Out +
4		Ground	I Out -
5	<b>A3</b>	V Out	I Out +
6		Ground	I Out -
7	<b>A4</b>	Not Available	Not Available
8		Not Available	Not Available

- The default analog output voltage setting of the M102E UV Fluorescence SO<sub>2</sub> Analyzer is 0 – 5 VDC with a range of 0 – 500 ppb.



- TO change these settings, see Sections 6.9.4 and 6.7 of the M101E Manual - P/N 04740 Rev A respectively.

### 3.6.1.2. M501-TRS Alarm Output Connections

The rear panel of the M501-TRS includes a terminal strip by which connections can be made to the converters internal temperature alarm for more information on this alarm see Section 6.5).

- Connect the input leads to your alarm-sensing device (e.g. datalogger) to the center two pins of the alarm output connector (see Figure 3-5).
- Make sure the load does not exceed the rated capacity of the relay.

### 3.6.2. Pneumatic Connections:

This section supercedes the information contained in Section 3.1.2 of the M101E Manual - P/N 04740 Rev A.

**CAUTION**

**To prevent dust from getting into the analyzer, it was shipped with small plugs inserted into each of the pneumatic fittings on the rear panel. Make sure that all dust plugs are removed before attaching exhaust and supply gas lines.**

Sample and calibration gases should only come into contact with PTFE (Teflon) or glass materials. They should not come in contact with FEP or stainless steel materials.

Figures 3-7 and 3-8 show the most common configurations for gas supply and exhaust lines to the Model 102E Analyzer. Figures 3-9, 3-10 & 3-11 show the connections for units with valve options installed.

Please refer to Figures 3-1 & 3.3 for the location of pneumatic connections at the rear panel of the M102E and the M501-TRS.

**Table 3-3: Inlet / Outlet Connector Nomenclature**

<b>M102E PNEUMATIC CONNECTERS</b>	
<b>REAR PANEL LABEL</b>	<b>FUNCTION</b>
<b>SAMPLE</b>	Connects the sample gas to the analyzer. When operating the analyzer without zero/span option, this is also the inlet for any calibration gases.
<b>EXHAUST</b>	Exhausts the gas sampled by the analyzer. Connect to an outside area away from people.
<b>SPAN</b>	On units with zero/span/shutoff valve options installed, connect a gas line to the source of calibrated span gas here.
<b>ZERO AIR</b>	On Units with zero/span valve or IZS option installed, this port connects the zero air gas or the zero air cartridge to the analyzer.
<b>TO CONVERTER</b>	Sample gas leaves the M102E to be conditioned by the M501-TRS via this port.
<b>FROM CONVERTER</b>	Sample gas returns to the M102E after being conditioned by the M501-TRS via this port.
<b>M501-TRS PNEUMATIC CONNECTERS</b>	
<b>REAR PANEL LABEL</b>	<b>FUNCTION</b>

<b>FROM ANALYZER</b>	Sample gas enters the M501-TRS from the M102E via this port.
<b>TO ANALYZER</b>	Sample gas leaves the M501-TRS to return to the M102E via this port.

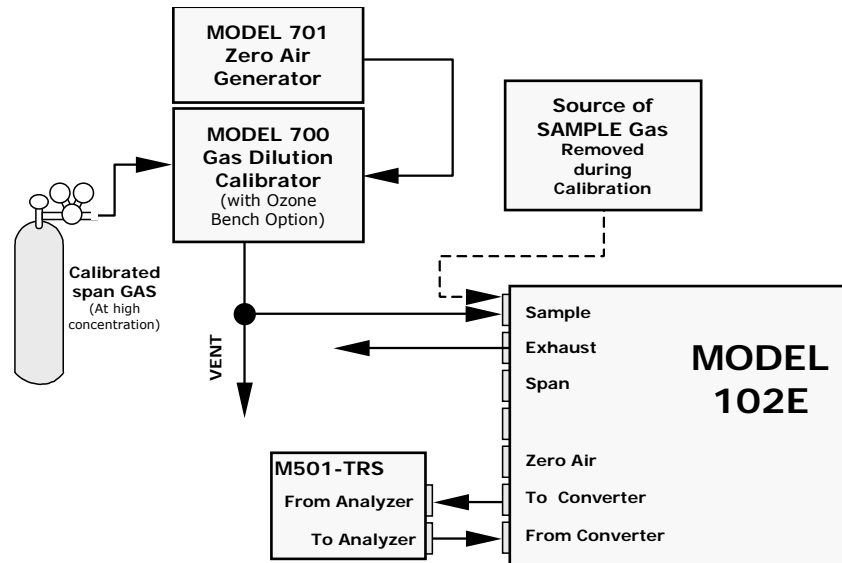

Figure 3-7: Pneumatic Connections–Basic Configuration–Using Gas Dilution Calibrator

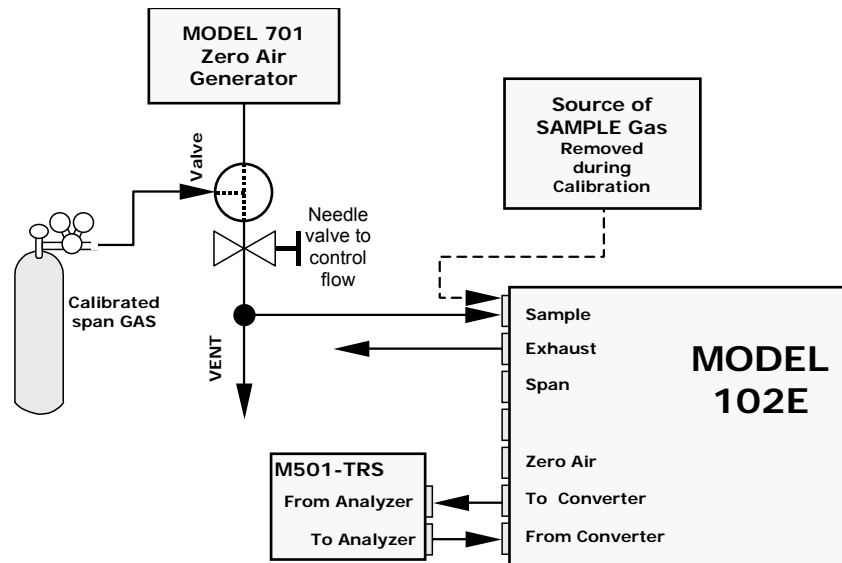

Figure 3-8: Pneumatic Connections–Basic Configuration–Using Bottled Span Gas

8. Attach the 1/4" exhaust line to the exhaust port.



**CAUTION**

The exhaust from the instrument needs to be vented outside the immediate area or shelter surrounding the instrument and conform to all safety requirements using a maximum of 10 meters of 1/4" PTFE tubing.

9. Attach the sample line to the sample inlet port. Ideally, the pressure of the sample gas should be equal to ambient atmospheric pressure.

**NOTE**

Maximum pressure of any gas at the sample inlet should not exceed 1.5 in-Hg above ambient pressure and ideally should equal ambient atmospheric pressure.

In applications where the sample gas is received from a pressurized manifold, a vent must be provided to equalize the sample gas with ambient atmospheric pressure before it enters the analyzer. The vented gas needs to be routed outside the immediate area or shelter surrounding the instrument.

10. Attach zero air and span gas supply lines as appropriate (see Figures 3-5 & 3.5).

- Zero air and span gas inlets should supply their respective gases in excess of the 700 cc<sup>3</sup>/min demand of the analyzer. Supply and vent lines should be of sufficient length and diameter to prevent back diffusion and pressure effects.
- For this type of analyzer, zero air and span gas are defined as follows:

**SPAN GAS**

- While it is possible to calibrate the M102E using SO<sub>2</sub> as the span calibration gas by setting the analyzers gas measurement mode to SO<sub>2</sub>, Teledyne Instruments recommends that H<sub>2</sub>S be used and that calibration operations be carried out with the analyzer's TRS gas measurement mode selected. Please note that verifying converter efficiency requires that the instrument be calibrated on both TRS and SO<sub>2</sub>, and the slope factors compared between the TRS and SO<sub>2</sub> modes.
- It is recommended that the H<sub>2</sub>S span gas be equal to 90% of the analyzer's selected reporting range.
- O<sub>2</sub> is a quenching agent in fluorescent Sulfur analyzers. If the balance gas is pure nitrogen, then false positive readings will result, both at zero and span. Therefore the user should either use cylinders with zero air as the balance gas, or should use higher concentration cylinders with an N<sub>2</sub> balance, and dilute further with zero air using a calibrator, such as the TAPI M700.

EXAMPLE: If the selected reporting rang is 0 ppb → 500 ppb, an appropriate span gas concentration would be 450 ppb H<sub>2</sub>S.

Cylinders of calibrated H<sub>2</sub>S gas traceable to NIST-Standard Reference Material specifications (also referred to as SRM's or EPA protocol calibration gases) are commercially available. Table 3-4 lists specific NIST-SRM reference numbers for various concentrations of H<sub>2</sub>S.

Table 3-4: NIST-SRM's Available for Traceability of H<sub>2</sub>S & SO<sub>2</sub> Calibration Gases

NIST-SRM <sup>4</sup>	TYPE	NOMINAL CONCENTRATION
2730	Hydrogen sulfide in N <sub>2</sub>	5000 ppb
2731	Hydrogen sulfide in N <sub>2</sub>	20 ppm

**ZERO AIR**

- A gas that is similar in chemical composition to the earth's atmosphere but without the gas(es) being measured by the analyzer, in this case total reduced sulfur (TRS). While TRS typically includes Hydrogen sulfide (H<sub>2</sub>S), Dimethyl sulfide (CH<sub>3</sub>)<sub>2</sub>, Dimethyl disulfide (CH<sub>3</sub>)<sub>2</sub>S<sub>2</sub> and Methyl mercaptan (MeSH), CH<sub>4</sub>S many other gases fall into this category as well. In addition other interferent gases may be present in ambient air as well.

To ensure that high quality zero air is available a zero air generator such as the Teledyne Instruments Model 701 should be used.

- If your analyzer is equipped with an IZS option, it is capable of creating zero air that is adequate for performing informal calibration checks, but a zero air generator such as the Teledyne Instruments Model 701 is still recommended for performing formal calibration operations.

11. Once the appropriate pneumatic connections have been made, check all pneumatic fittings for leaks using a procedure similar to that defined in Section 11.5.1 of the M101E Manual - P/N 04740 Rev A.

**3.6.2.1. Connections with Internal Valve Options Installed**

If your analyzer is equipped with either the zero/span valve option (Option 50) or the internal zero/span option (Option 51), the pneumatic connections should be made as shown in Figures 3-9; 3-10 & 3-11:

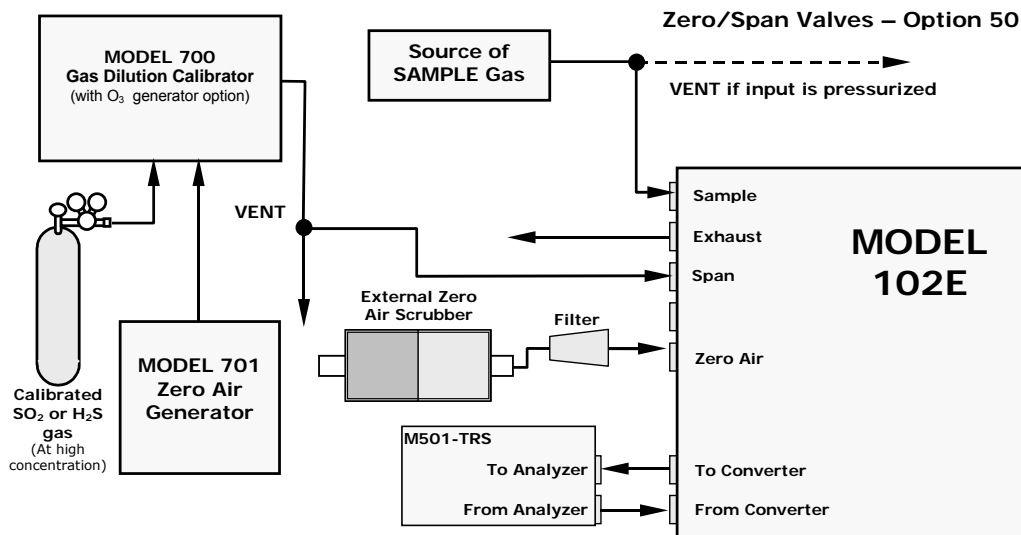

Figure 3-9: Basic Pneumatic Connections for Units with Zero/Span Valve Option

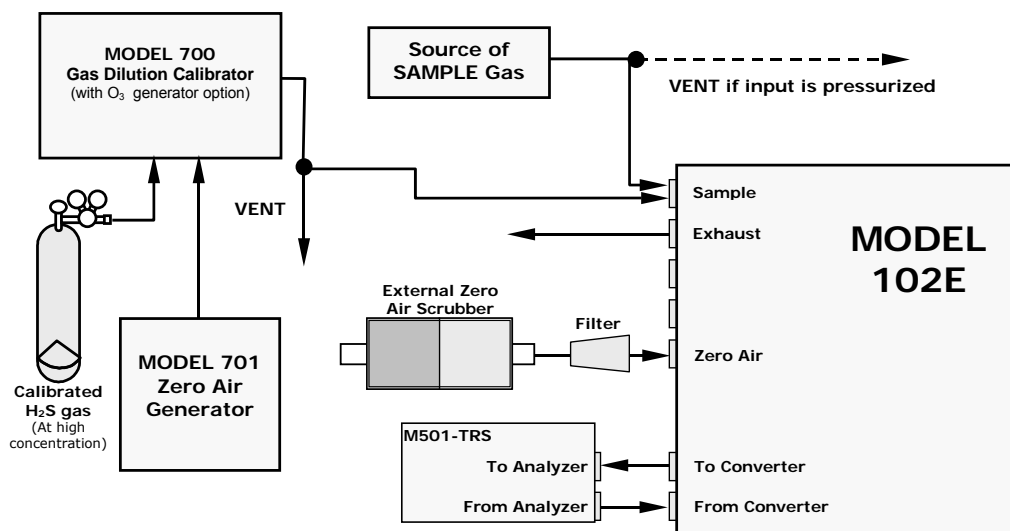

Figure 3-10: Pneumatic Connections for Formal Calibration of Units with an IZS Valve Option

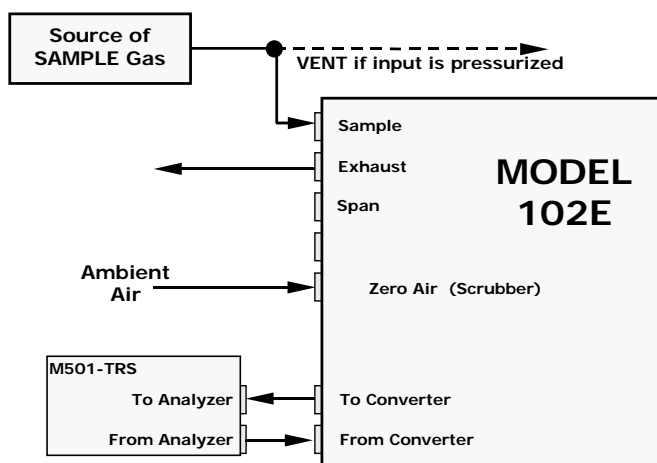

Figure 3-11: Pneumatic Connections for Informal Calibration Checks of Units with IZS Valve Option

#### NOTE

Gas flow must be maintained at all times for units with IZS Options installed. The IZS option requires a permeation tube (customer supplied) which emits H<sub>2</sub>S. Insufficient gas flow can build up H<sub>2</sub>S to levels that will damage the instrument.

Remove the permeation device when taking the analyzer out of operation.

## 3.7. Initial Operation

### 3.7.1. Startup / Warm Up of the M102E

Startup procedures and warm up behavior of the M102E are identical to those described in Sections 3.2.1 and 3.2.2 of the M101E Manual - P/N 04740 Rev A.

#### Possible Warning Messages at Start-Up

Warning messages for the M102E is the same as the list of warning messages included in appendix A—3 of the M101E Manual - P/N 04740 Rev A with the exception that there is no **CONV TEMP WARNING** (converter Temperature Warning).

### 3.7.2. Functional Check of the M102E

To performing an initial functional check of the M102E follow the steps contained in Section 3.2.4 of the M101E Manual - P/N 04740 Rev A.

#### Test Functions

The following diagram supercedes the one found in Step 2 of Section 3.2.4 of the M101E Manual - P/N 04740 Rev A.

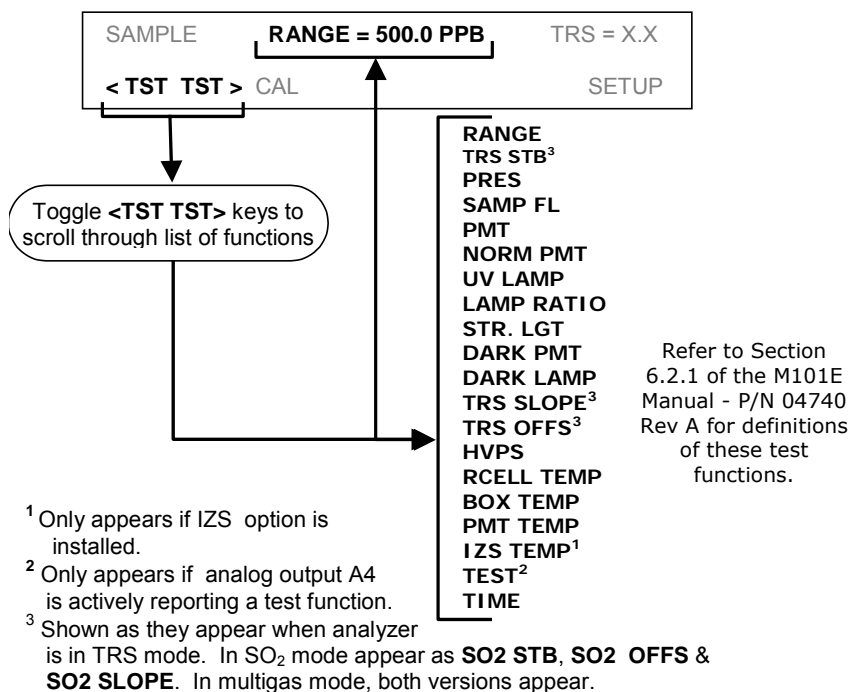

### 3.7.3. Startup / Warm Up of the M501-TRS

After electrical and pneumatic connections are made, turn on the instrument and pump power. The exhaust fan should start.

The M501-TRS' temperature controller is preprogrammed at the factory so no special setup operation is required. The temperature controller (see Figure 3-12) should immediately come on in operation mode: the current temperature of the converter oven should the display immediately appear in the display area and the process value (PV) LED should be lit.

It may take as much as 30 minutes for the oven to reach its nominal operating temperature.

During that initial warm up period the high and low alarms and the M501-TRS single alarm output are disabled. Both the internal alarms and the alarm output will be automatically enabled once the converter oven temperature rises above the lower alarm limit.

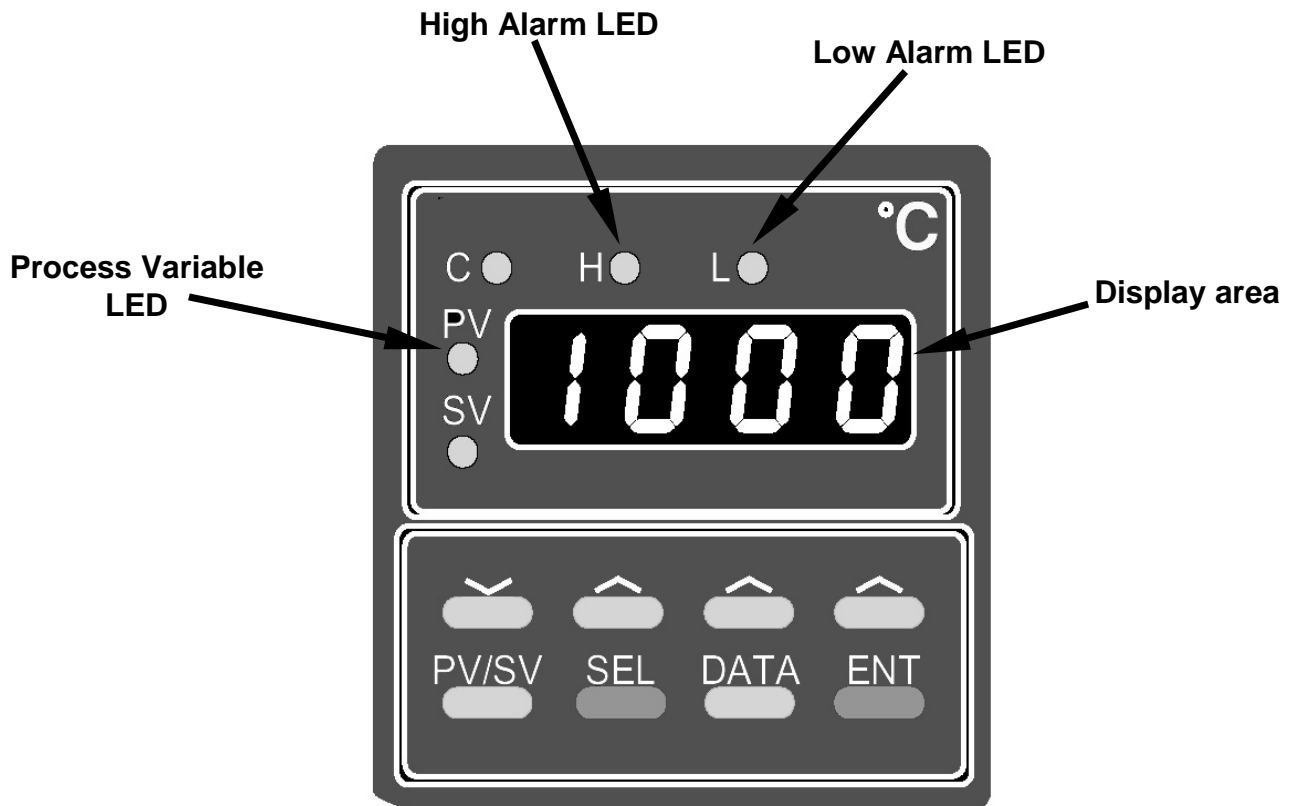

Figure 3-12: M501-TRS Temperature Controller Startup



## 3.8. Initial Calibration

Initial calibration of the M102E should be performed with:

- Zero air supplied by a zero air generator such as the Teledyne Instruments' M701;
- Calibrated H<sub>2</sub>S span gas of the appropriate concentration:
- With external pneumatic connections as described in Figures 3-7 through 3-11 of this addendum, and;
- Using the information and procedure included in Section 3.3 of the M101E Manual - P/N 04740 Rev A.

No initial calibration of the M501-TRS temperature controller is required.

### NOTE

**Once you have completed the above set-up procedures, please fill out the quality questionnaire that was shipped with your unit and return it to Teledyne Instruments. This information is vital to our efforts in continuously improving our service and our products. Thank you.**

---

## User Notes:



## 4. OPTIONAL HARDWARE AND SOFTWARE

This section includes descriptions of the hardware and software options available for the Model 102E analyzer and M501-TRS converter that are different from or not included in Chapter 5 of the M101E Manual - P/N 04740 Rev A. For all other available options see that document.

For assistance with ordering these options please contact the sales department of Teledyne Instruments at:

**TOLL-FREE:** 800-324-5190  
**TEL:** +1 858-657-9800  
**FAX:** +1 858-657-9816  
**E-MAIL:** [apisales@teledyne.com](mailto:apisales@teledyne.com)  
**WEB SITE:** <http://www.teledyne-api.com>

### 4.1. Rack Mount Kits (Options 20a, 20b, 21, 22 & 81)

The following table supercedes the one included in Section 5.1 of the M101E Manual - P/N 04740 Rev A.

OPTION NUMBER	DESCRIPTION
OPT 20A	Rack mount brackets with 26 in. chassis slides.
OPT 20B	Rack mount brackets with 24 in. chassis slides.
OPT 21	Rack mount brackets only
OPT 22	Rack Mount for M501-TRS
OPT 81	Rack Mount for M501-TRS with slides

### 4.2. Calibration Valves Options

#### 4.2.1. Zero/Span Valves (Option 50) & Internal Zero/Span Gas Generator (Option 51)

The description of the construction and operation for the zero span and IZS valve options for the M102E TRS is identical to that information contained in Section 5.4 of the M101E Manual - P/N 04740 Rev A.

The internal pneumatic flow or the M102E with either of these options installed is however different. See:

- Figure 4-1 for an illustration of the M102E internal gas flow with the zero/span valves (option 50), and;
- Figure 4-2 for an illustration of the M102E internal gas flow with the IZS valve (option 1).

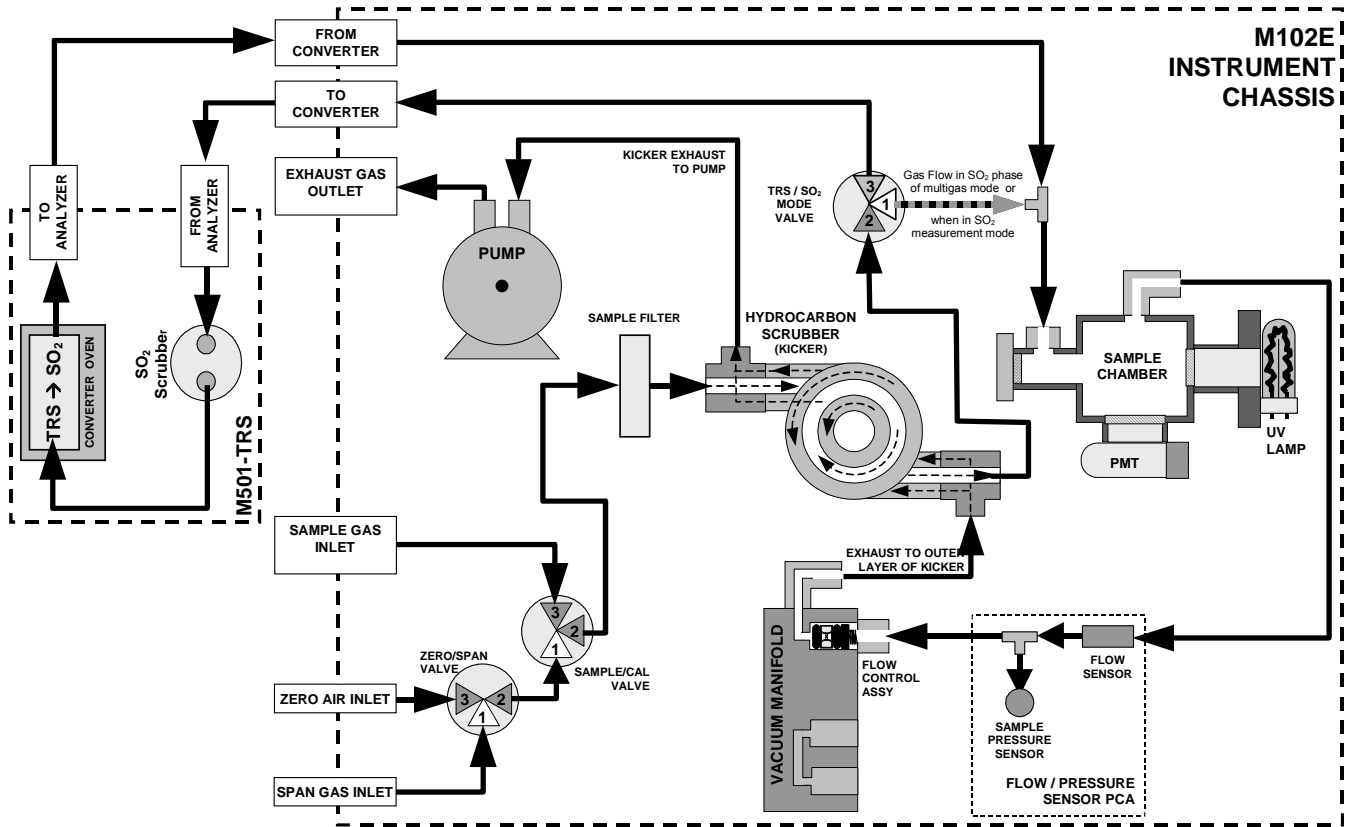

Figure 4-1: Internal Pneumatic Diagram of the M102E With Z/S Option Installed.

The following table describes the state of each valve during the analyzer’s various operational modes.

Table 4-1: Zero/Span Valve Operating States

MODE	VALVE	CONDITION	VALVE PORT CONNECTION (FIG. 5-2)
SAMPLE	Sample/Cal	Open to SAMPLE inlet	3 → 2
	Zero/Span	Open to ZERO AIR inlet	3 → 2
ZERO CAL	Sample/Cal	Open to zero/span inlet	1 → 2
	Zero/Span	Open to ZERO AIR inlet	3 → 2
SPAN CAL	Sample/Cal	Open to zero/span inlet	1 → 2
	Zero/Span	Open to SPAN GAS inlet	1 → 2

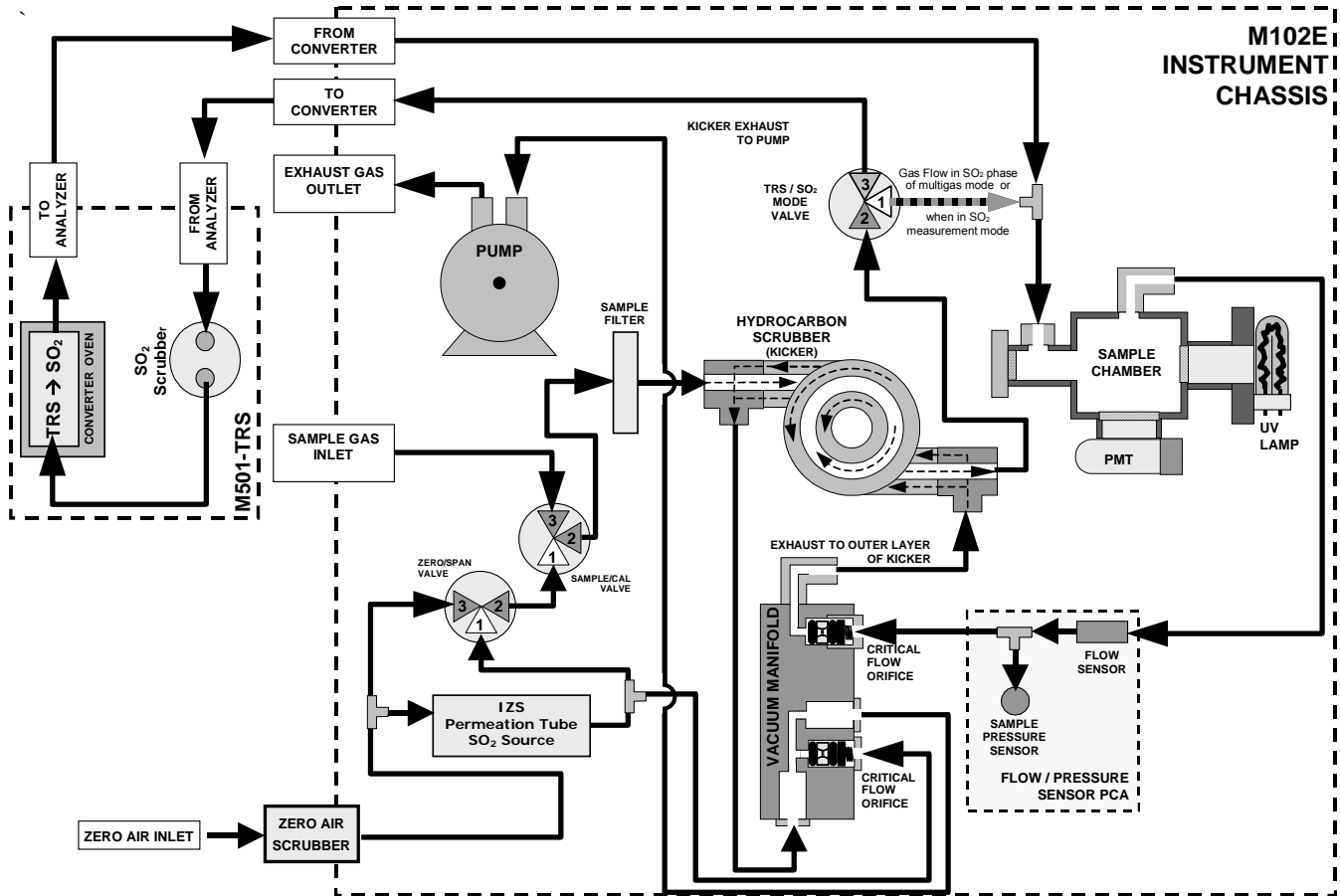

Figure 4-2: Internal Pneumatic Diagram of the M102E with IZS Options Installed.

The following table describes the state of each valve during the analyzer's various operational modes.

Table 4-2: IZS Valve Operating States

MODE	VALVE	CONDITION	VALVE PORT CONNECTIONS
SAMPLE	Sample/Cal	Open to SAMPLE inlet	3 → 2
	Zero/Span	Open to ZERO AIR inlet	3 → 2
ZERO CAL	Sample/Cal	Open to zero/span valve	1 → 2
	Zero/Span	Open to ZERO AIR inlet	3 → 2
SPAN CAL	Sample/Cal	Open to zero/span valve	1 → 2
	Zero/Span	Open to SPAN GAS inlet	1 → 2

## 4.3. Additional Manuals

### 4.3.1. Printed Manuals (P/N 049880000)

Additional printed copies of this addendum are available from Teledyne Instruments

### 4.3.2. Addendum on CD (Part number 049880200)

This addendum is also available on CD. The electronic document is stored in Adobe Systems Inc. Portable Document Format (PDF) and is viewable with Adobe Acrobat Reader® software, downloadable for free at <http://www.adobe.com/>

The CD version of the addendum has many advantages:

Fully searchable text.

Hypertext links for figures, tables, table of contents and embedded references for quick access of individual addendum portions.

A list of thumbnails, chapters and sections displayed at the left of the text.

Internet links embedded in the addendum will take you to the corresponding web site (requires an internet connection).

---

## User Notes:

## 5. M102E OPERATING INSTRUCTIONS

### NOTE

For the most part the operation instruction for the M102E are the same as those described in Chapter 6 of the M101E Manual - P/N 04740 Rev A with the exception that the terms "TRS" & "total reduced sulfur" should be substituted for the terms "H<sub>2</sub>S" & "hydrogen sulfide" unless otherwise stated in this addendum.

### 5.1.1. M102E Analog Output Signals

The information contained in Section 6.7.1 of the M101E Manual - P/N 04740 Rev A is correct except that the test channel output is located on analog output **A3** rather than **A4**.

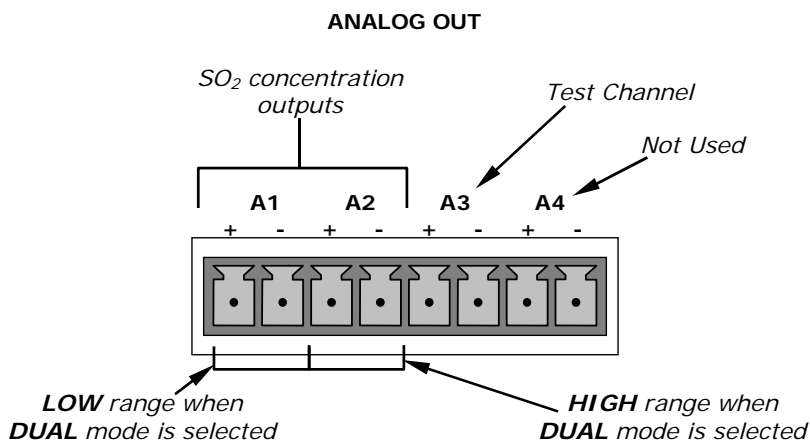

Figure 5-1: Analog Output Connector Key

### NOTE

On analyzers with the SO<sub>2</sub>-TRS multigas gas measurement option available, the outputs of A1 and A2 correspond to:

<u>Output Channel</u>	<u>SO<sub>2</sub> Mode</u>	<u>SO<sub>2</sub> - TRS Mode</u>	<u>TRS Mode</u>
A1 ↔	SO <sub>2</sub> ↔	SO <sub>2</sub> ↔	TRS
A2 ↔	SO <sub>2</sub> ↔	TRS ↔	TRS

As the instrument switches from TRS mode to SO<sub>2</sub> mode and back, only the reporting range and analog output associated with the gas currently being measured will be active. The reporting range and analog output for the gas not being measured will continue to report the last valid reading.

The output, labeled **A3** is special. It can be set by the user (see Section 6.9.10 of the M101E Manual - P/N 04740 Rev A) to output many of the parameters accessible through the <TST TST> keys of the units Sample Display.

Output **A4** is not available on the Model 102E Analyzer.

## 5.1.2. Setting the M102E Gas Measurement Mode

Setting the gas measurement mode on the M102E is identical to the method described in Sections 6.8.1 of the M101E Manual - P/N 04740 Rev A except that the available measurement ranges are:

**Table 5-1 M102E gas Measurement Modes**

GAS MODE	DESCRIPTION
TRS	The sample gas stream is stripped of any ambient SO <sub>2</sub> by a special chemical scrubber, then passed through a catalytic converter that changes the TRS present into SO <sub>2</sub> which is then measured using the UV Fluorescence method
SO <sub>2</sub>	The sample gas stream bypasses the SO <sub>2</sub> Scrubber and catalytic converter allowing the only ambient SO <sub>2</sub> to be measured.
TRS –SO <sub>2</sub>	The switching valve alternates the gas stream between the two paths at regular intervals allowing the instrument to measure both gases.

## 5.2. SETUP – DIAG: Using the Diagnostics Functions

### 5.2.1. M102E Analog I/O Configuration

The following table supercedes Table 6-11 of the M101E Manual - P/N 04740 Rev A

**Table 5-2: Analog Output Pin Assignments**

PIN	ANALOG OUTPUT	VOLTAGE SIGNAL	CURRENT SIGNAL
1	A1	V Out	I Out +
2		Ground	I Out -
3	A2	V Out	I Out +
4		Ground	I Out -
5	A3	V Out	not available
6		Ground	not available
7-8	A3	Not Used	Not Used

See Figure 3-4 for a the location of the analog output connector on the instruments rear panel.



## 5.2.2. M102E Test Channel Output

The following table supercedes Table 6-14 of the M101E Manual - P/N 04740 Rev A

**Table 5-3: Test Parameters Available for Analog Output A4**

TEST CHANNEL	TEST PARAMETER RANGE <sup>1</sup>
NONE	Test channel is turned off
PMT READING	0-5000 mV
UV READING	0-5000 mV
SAMPLE PRESSURE	0-40 in-Hg-A
SAMPLE FLOW	0-1000 cm <sup>3</sup> /min
RCELL TEMP	0-70° C
CHASSIS TEMP	0-70° C
IZS TEMP	0-70° C
PMT TEMP	0-50° C
CHASSIS TEMP	0-70° C
HVPS VOLTAGE	0-5000 V
<sup>1</sup> This refers to the voltage range of the parameter and not the output signal of the test channel.	

Once a TEST function is selected, the instrument begins to report a signal on the **A36** output and adds **TEST=** to the list of test functions viewable on the display (just before the TIME display).

## 5.3. SETUP – COMM: Setting Up the M102E's Communication Ports

### 5.3.1. M102E ID Code

The default ID code for all M102E analyzers is **102**.

To edit the instrument's ID code, see Section 6.10.1 of the M101E Manual - P/N 04740 Rev A.

### 5.3.2. M102E Ethernet Host Name

The default name for all Teledyne Instruments Model 102E analyzers is **M102E**.

To change the Ethernet Host Name see Section 6.10.6.4 of the M101E Manual - P/N 04740 Rev A.

## 5.4. Remote Operation of the Analyzer

### 5.4.1. Control Inputs

The description of the control inputs in Section 6.12.1.2 of the M101E Manual - P/N 04740 Rev A in correctly shows an external low span cal input. This is not correct. Neither the M102E nor the M102E has an external low span cal input.

The following table and figures supercede Table 6-23 and Figures 6-18 & 6-19 of the M101E Manual - P/N 04740 Rev A respectively.

**Table 5-4: M102E Control Input Pin Assignments**

INPUT	STATUS	CONDITION WHEN ENABLED
A	External Zero Cal	Zero calibration mode is activated. The mode field of the display will read ZERO CAL R.
B	External Span Cal	Span calibration mode is activated. The mode field of the display will read SPAN CAL R.
C, D, E, & F		Unused
↓	Digital Ground	Provided to ground an external device (e.g., recorder).
U	DC Power For Input Pull Ups	Input for +5 VDC required to activate inputs A - F. This voltage can be taken from an external source or from the "+" pin.
+	Internal +5v Supply	Internal source of +5V which can be used to activate inputs when connected to pin U.

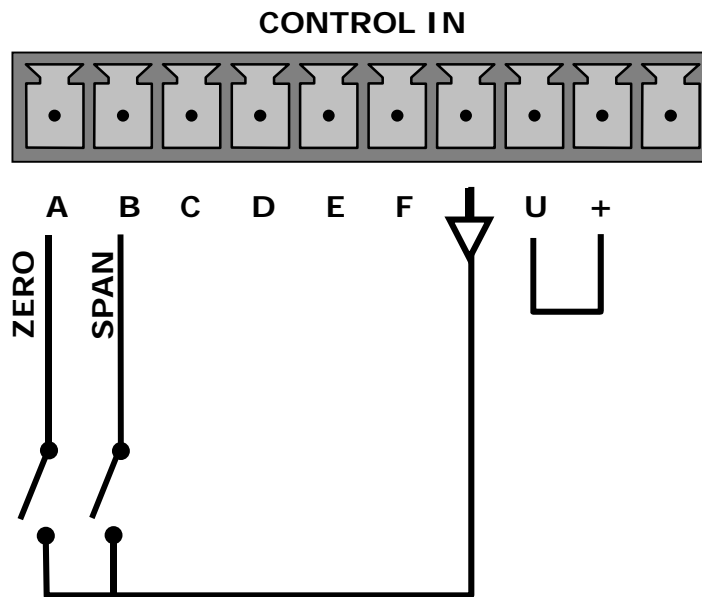

**Figure 5-2: Control Inputs with local 5 V power supply**

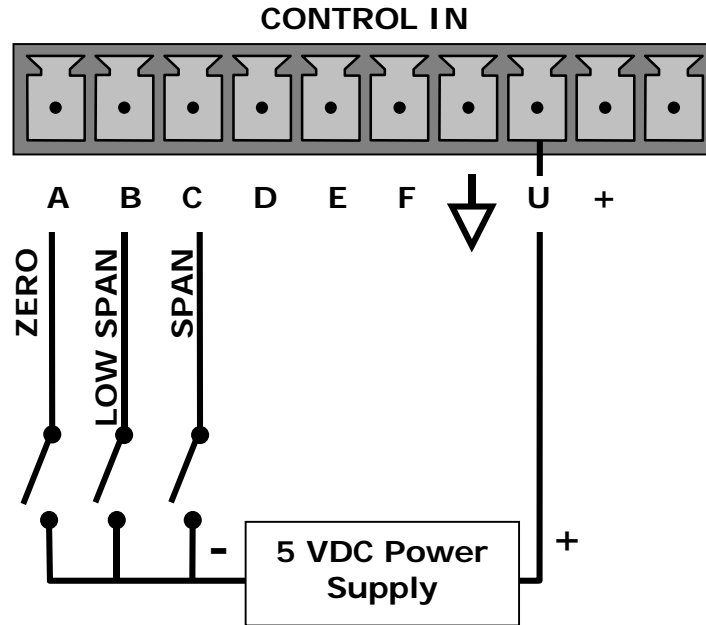

Figure 5-3: Control Inputs with external 5 V power supply

## 5.4.2. Using the M102E with a Hessen Protocol Network

### 5.4.2.1. M102E Hessen Protocol Gas ID List.

The default Hessen Gas Id's for all M102E analyzers are:

Table 5-5: M102E Default Hessen Gas ID's

Gas Type	Hessen Gas ID
SO <sub>2</sub>	111
TRS	112

To edit the instrument's ID code, see Section 6.12.4.6 of the M101E Manual - P/N 04740 Rev A.

### 5.4.2.2. Setting Hessen Protocol Status Flags

The following table supercedes Table 6-29 of the M101E Manual - P/N 04740 Rev A/

**Table 5-6: Default Hessen Status Bit Assignments**

STATUS FLAG NAME	DEFAULT BIT ASSIGNMENT
<b>WARNING FLAGS</b>	
SAMPLE FLOW WARNING	0001
PMT DET WARNING	0002
UV LAMP WARNING	0002
HVPS WARNING	0004
DARK CAL WARNING	0008
RCELL TEMP WARNING	0010
IZS TEMP WARNING	0020
PMT TEMP WARNING	0040
CONV TEMP WARNING	1000
<b>OPERATIONAL FLAGS</b>	
In Manual Calibration Mode	0200
In Zero Calibration Mode	0400
In Span Calibration Mode	0800
<b>UNITS OF MEASURE FLAGS</b>	
UGM	0000
MGM	2000
PPB	4000
PPM	6000
<b>SPARE/UNUSED BITS</b>	0080, 0100, 1000, 8000
<b>UNASSIGNED FLAGS</b>	
Box Temp Warning	Front Panel Warning
Sample Press Warning	Analog Cal Warning
System Reset	Cannot Dyn Zero
Rear Board Not Detected	Cannot Dyn Span
Relay Board Warning	Invalid Conc

## User Notes:

## 6. M501-TRS OPERATING INSTRUCTIONS



### CAUTION !

DO NOT OPERATE WITHOUT THE COVER OF THE M501TS CONVERTER INSTALLED.

OVEN TEMPERATURE WILL NOT REGULATE PROPERLY WITHOUT THE COVER IN PLACE.

### NOTE:

Changing the Converter temperature from the value preprogrammed at the factory may have undesirable effects of TRS converters efficiency.

Do not change this value unless absolutely necessary or unless directed to do so by Teledyne Instruments customer service.

### 6.1. Basic M501-TRS Controls

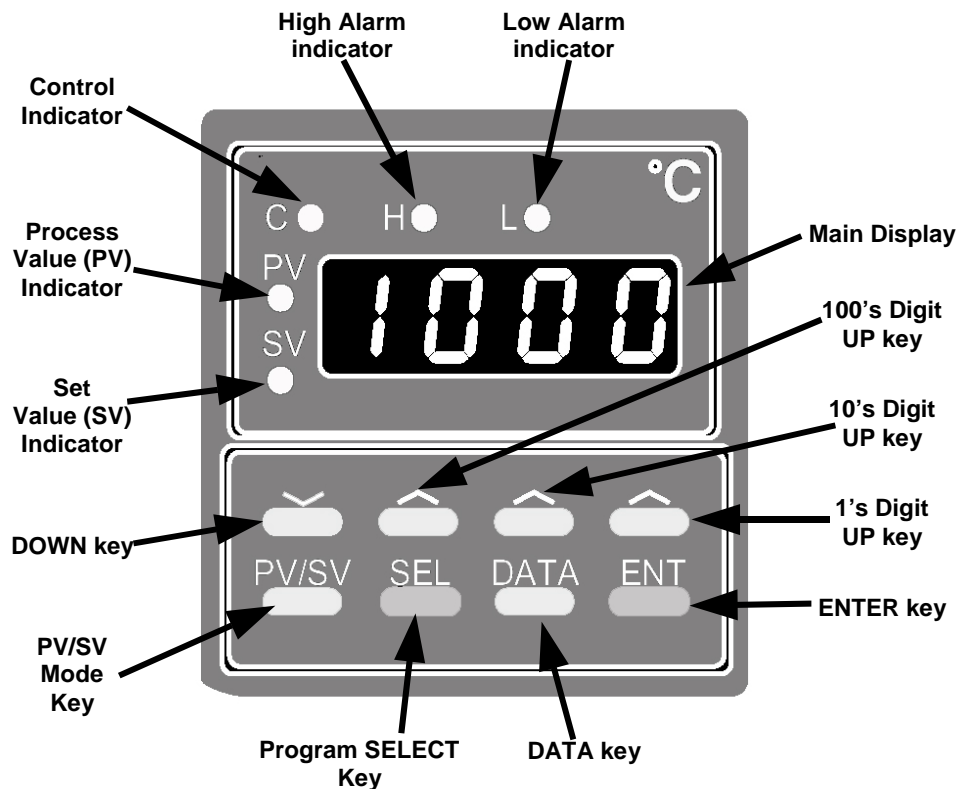

Figure 6-1: M501-TRS Temperature Controls

Table 6-1: M501-TRS Temperature Controls and Definitions

NAME	FUNCTION
<b>Main Display</b>	A 4-digit, 7 segment LED display on which the current value of the PV and the SV as well as error codes and programming parameters and data are all displayed.
<b>Process value (PV) indicator</b>	When lit indicates that the value on the main display is the process value (SV).
<b>PV/SV Mode key</b>	Toggling this key switches the main display between the PV and the SV.
<b>Set value Indicator</b>	When lit indicates that the value on the main display is the set value (SV).
<b>Program SELECT key</b>	To access the Primary Parameter Menu - Press and release this key once To access the Secondary Parameter Menu - Press and hold this key for 3 sec., then release. Repeatedly pressing this key scrolls through the list of available parameter for whatever menu is selected in ascending order.
<b>DATA key</b>	Displays the current setting assigned to the parameter selected with the SEL/DOWN/100's UP keys
<b>ENTER key</b>	Once the value of a parameter is changed, press this key to store the new value in memory.
<b>1's Digit UP key</b>	Press once to select the 1's digit of the display when in numeric mode. Hold the key down to continuously increment the 1's digit. When "9" is reached the digit loops back to "0"
<b>10's Digit UP key</b>	Same as 1's Digit UP key but for 10's digit.
<b>100's Digit UP key</b>	Same as 1's Digit UP key but for 100's digit. When "9" is reached the digit loops back to "0" and the 1000's digit is incremented by one.
<b>DOWN key</b>	Decrements the numerical value by one digit of which ever display position (1, 10, or 100) selected with by pressing the appropriate UP key. In Program mode, where various parameters are displayed, repeatedly pressing this key scrolls through the list of available parameter in descending order
<b>Control Indicator</b>	Lit when the controller is actively controlling the heater temperature.
<b>High Alarm Indicator</b>	Lit when the PV equals or exceeds the upper alarm limit.
<b>Low Alarm Indicator</b>	Lit when the PV equals or falls below the lower alarm limit.

## 6.2. To Display The Current Temperature:

If the **Process value (PV) indicator** is lit. the process value is currently being displayed.

If it is not lit Press the PV/SV mode key.

## 6.3. To Manually Adjust the Converter Oven Temperature:

	<p><b>CAUTION !</b></p> <p><b>DO NOT SET THE TEMPERATURE HIGHER THAN 1050OC</b></p>
---	---

1. Set the main display to show the current value of the set variable by pressing the PV/SV mode key.
2. To set each digit:
  - a. Press the up-arrow under that digit once. The digit will flash.
  - b. to increment that digit, press and hold the digit until the appropriate number is displayed.
  - c. To decrement that digit press and hold the DOWN key until the appropriate number is displayed.
  - d. To increment/decrement the 1000's digit it is necessary to adjust increment/decrement the 100's digit up and down. Each time the 100's digit passes "0" the 1000s digit will increment or decrement correspondingly.
3. Once the desired value is reached, press the ENT key to store the new set value
4. Return the main display to process mode by pressing the PV/SV mode key once

EXAMPLE to change the set value from 950 to equal 1010.

ACTION	RESULT
Press the PV/SV mode key	The SV indicator will lit up and the display will show 950.
Press the 10's UP key once	The 10's digit will begin to blink
Press the DOWN key	The 10's digit will decrement from "5". Release the DOWN key when the 10's digit reads "1".
Press the 100's UP Key once	The 100's digit will begin to blink
Press and hold the 100's UP key	The 100's digit will increment from "9". When it passes "0" the 1000's digit will increment to "1". Release the 100's UP key.
--	The Display should now read "1010"
Press the ENTER key	The new set value is recorded
Press the PV/SV mode key	The current level of the process value will be displayed.

## 6.4. Autotune the Temperature Controller:

The M501-TRS controller includes an auto tune feature which allows the controller to find and set optimum values for various process control parameters so that the controller can establish and maintain the converter oven at the temperature set value in the most stable and efficient manner.

### NOTE

**Before initiating the autotune feature make sure that the converter temperature oven has reached a stable, constant temperature.**

### 6.4.1. Initiating the Autotune Process:

1. Press the SELECT key once. The main display will show **P**
2. Use the SELECT , DOWN or 100's UP key to scroll through the primary menu parameters until the display shows **A7** (AT =Autotune).
3. Press the DATA key once. The display will show **0** (zero = Off).
4. Press the 1's UP key once. The display will show **1** (1 = autotune based on set point value).
5. Press the ENTER key to begin the autotune process. A blinking decimal point will appear at the bottom right-hand corner of the main display.
6. Wait until the blinking light stops. This may take up to 30 minutes.
7. The autotune process is finished. The autotune parameter value will automatically reset to zero (off).
8. Press the PV/SV mode key to return to operational mode.

### Note

**The P-I-D parameters calculated by autotuning will be retained even if the power is lost. However, if the power is turned off during the auto-tuning process, you must restart autotuning.**



## 6.4.2. Aborting the Autotune Process:

1. Press the DATA key once. The display will show **1** (1).
2. Press the 1's UP key once. The **1** will begin blinking
3. Press the DOWN key once. The display will show **0** (zero).
4. Press the ENTER key once.
5. Press the PV/SV mode key to return to operational mode.

### Note

**Auto-tuning MUST to be repeated if there is a significant change in the set value.**

**If the temperature begins to oscillate excessively around the set value, it may be necessary to repeat the autotune procedure.**

## 6.5. M501TRS Alarm Relay Adjustment

To set the High and Low Alarm points:

6. Press the SELECT key once. The main display will show **P**
7. Use the SELECT , DOWN or 100's UP key to scroll through the primary menu parameters until the display shows either **AL** (AL = Alarm Low) or **AH** (AH = High Alarm).
8. Press the DATA key once. The current value of the alarm limit will be displayed.
9. To set each digit:
  - a. Press the up-arrow under that digit once. The digit will flash.
  - b. To increment that digit, press and hold the digit until the appropriate number is displayed.
  - c. To decrement that digit press and hold the DOWN key until the appropriate number is displayed.
  - d. To increment/decrement the 1000's digit it is necessary to adjust increment/decrement the 100's digit up and down. Each time the 100's digit passes "0" the 1000s digit will increment or decrement correspondingly.
10. Once the desired value is reached, press the ENT key to store the new set value
11. Press the PV/SV mode key to return to operational mode.



## **7. CALIBRATION PROCEDURES**

### **7.1. M102E Calibration**

Calibration of the M102E should be performed according to the procedures described in Chapters 7 & 8 of the M101E Manual - P/N 04740 Rev A.

**NOTE**

**It is recommended that the M102E be calibrated in TRS gas measurement mode using H<sub>2</sub>S as a span gas.**

If you are using the M102E for US-EPA controlled monitoring of SO<sub>2</sub>, see Chapter 8 of the M101E Manual (P/N 04740 Rev A) for information on the EPA calibration protocol.

### **7.2. M501-TRS Calibration**

The M501-TRS converter does not require field calibration.

---

## **USER NOTES:**



## 8. INSTRUMENT MAINTENANCE

The following table supercedes Table 9-1 of the M101E Manual - P/N 04740 Rev A

**Table 8-1: M102E Preventive Maintenance Schedule**

ITEM	ACTION	FREQUENCY	CAL CHECK	M101E MANUAL SECTION	DATE PERFORMED						
M501 SO2 scrubber	Replace scrubber material	As required	Yes	8.1.1.3 of this addendum							
<sup>1</sup> Particulate filter	Change particle filter	Weekly	No	9.3.1							
Verify test functions	Review and evaluate	Weekly	No	Appendix C							
Zero/span check	Evaluate offset and slope	Weekly	--	7.3, 7.6, 7.9							
<sup>1</sup> Zero/span calibration	Zero and span calibration	Every 3 months	--	7.2, 7.4, 7.5, 7.7, 7.8							
<sup>1</sup> External zero air scrubber (option)	Exchange chemical	Every 3 months	No	9.3.4							
<sup>1</sup> Perform flow check	Check Flow	Every 6 Months	No	11.5.2							
<sup>1</sup> Sample chamber optics	Clean windows and filters	Annually or as necessary	Yes	9.3.6							
<sup>1</sup> Critical flow orifice & sintered filters	Replace	Annually	Yes	9.3.7							
Internal IZS Permeation Tube	Replace	Annually	YES	9.3.2							
Perform pneumatic leak check	Verify Leak Tight	Annually or after repairs involving pneumatics	Yes	11.5.1							
<sup>2</sup> pump diaphragm	Replace	Every 2 years, or as necessary	Yes	See instruction in diaphragm kit							
PMT sensor hardware calibration	Low-level hardware calibration	On PMT/ preamp changes if $0.7 < \text{SLOPE}$ or $\text{SLOPE} > 1.3$	Yes	11.6.3							

<sup>1</sup> These Items are required to maintain full warranty, all other items are strongly recommended.

<sup>2</sup> A pump rebuild kit is available from Teledyne Instruments Customer Service including all instructions and required parts (see Appendix B for part numbers).

## 8.1. Additional and Updated Maintenance Procedures

The following procedures need to be performed regularly as part of the standard maintenance of the Model 102E.

### 8.1.1. Maintaining the SO<sub>2</sub> Scrubber

This section REPLACES Section 9.3.3 of the M101E Manual - P/N 04740 Rev A.

Unlike the M101E which includes an internal scrubber to remove SO<sub>2</sub> from the sample gas before the H<sub>2</sub>S → SO<sub>2</sub> conversion takes place, the M102E relies on the SO<sub>2</sub> scrubber of the M501-TRS to perform the same function.

The SO<sub>2</sub> scrubber of your M501-TRS utilizes a consumable compound to absorb SO<sub>2</sub> from the sample gas before the TRS is converted to SO<sub>2</sub>. This material must be replaced periodically in order for the analyzer to continue measuring TRS accurately and reliability.

This material is capable of efficiently scrubbing SO<sub>2</sub> for up to 1000 ppm-hours. This means that if the SO<sub>2</sub> content of the sample gas is typically around 100 ppb, the scrubber will function for approximately 10,000 hours, a little over 13 months. If, however, the typical ambient SO<sub>2</sub> level of the sample gas is 250 ppb, the scrubber would only last for approximately 4000 hours or about 5 ½ months.

#### 8.1.1.1. Predicting When the SO<sub>2</sub> Scrubber Should Be Replaced.

To determine how long the SO<sub>2</sub> scrubber will operate efficiently:

1. Measure the amount of SO<sub>2</sub> in the sample gas.
  - If your M102E has the multigas measurement options activated, this can be done by following instructions found in Section 6.8.1 of the M101E Manual (P/N 04740 Rev A) and selecting **MEASURE MODE = SO<sub>2</sub>**.
  - Let the analyzer operate for 30 minutes, then note the SO<sub>2</sub> concentration.
2. Divide 1 000 by the SO<sub>2</sub> concentration.

EXAMPLE: If the SO<sub>2</sub> concentration is 125 ppb:

$$\begin{aligned}\text{Operational hours} &= 1000 \text{ ppm/hr} \div 0.125 \text{ ppm} \\ \text{Operational hours} &= 100\,000 \text{ ppb/hr} \div 125 \text{ ppb} \\ \text{Operational hours} &= 8000 \text{ hrs}\end{aligned}$$

### **8.1.1.2. Checking the Function of the SO<sub>2</sub> Scrubber**

To check to see if your SO<sub>2</sub> scrubber is operating properly perform the following test:

1. Set the analyzer for TRS gas measurement mode (see 6.8.1 of the M101E Manual - P/N 04740 Rev A).
2. Set the reporting range to range of 1000 PPB (see Sections 6.7.4; 6.7.5 & 6.7.6 of the M101E Manual - P/N 04740 Rev A).
3. Introduce a gas mixture into the sample gas stream that includes 500 PPB of SO<sub>2</sub>.
  - An increase of more than 10 PPB in the TRS reading is an indication that the efficiency of the scrubber is decreasing to the point that the absorbing material should be replaced.

### **8.1.1.3. Changing the SO<sub>2</sub> Scrubber Material**

1. Input zero air for 5 minutes
2. Turn off the M501-TRS
3. Locates the SO<sub>2</sub> scrubber cartridge on the right side of the converter: It looks like a big white cylinder (See Figure 3-2 of this addendum).
4. Undo the two 1/4 inch fittings on the top of the scrubber
5. Remove the two screws holding the scrubber to the instrument chassis and remove the scrubber
6. Take the two Teflon fittings off the instrument.
7. Empty the SO<sub>2</sub> scrubbing material into a hazmat bin
8. Fill each side of the scrubber with new SO<sub>2</sub> scrubber material until it is 1/2 inch from the bottom of the thread lines ( about 1 inch from the top of the scrubber ), do not fill it too high or the fitting will compact the material, causing a restriction in the gas flow.
9. Remove the Teflon tape from both of the removed fittings, and wrap them with new Teflon tape.
10. Install both fittings back onto the scrubber.
11. Put the scrubber back into the analyzer and replace the two screws on the bottom.
12. Screw the two 1/4" fittings back onto the top of the scrubber, they can be hooked up either way.
13. Return analyzer to normal operation

---

## **User Notes:**





## 9. THEORY OF OPERATION

The M102E is a modified M101E which, when used in conjunction with a M501-TRS determines the concentration of total reduced sulfur (TRS), in a sample gas drawn through the instrument. In most ways the theory of operation of the M102E & M501-TRS system is identical to the M101E theory of operation as described in Chapter 10 of the M101E Manual - P/N 04740 Rev A.

This section describes those areas where differences between the M102E and the M101E exist as well as updated information made available since the publication date of the M101E Manual - P/N 04740 Rev A.

### 9.1. Measurement Principle

This section supercedes Section 10.1 of the M101E Manual - P/N 04740 Rev A

#### 9.1.1. TRS Conversion

The M102E TRS analyzer is basically an SO<sub>2</sub> analyzer with a TRS → SO<sub>2</sub> converter (the M501-TRS) inserted into the gas stream before the sample gas enters the sample chamber.

The M501-TRS, receives sample gas from the M102E after it has been passed through a particulate filter and has been scrubbed of hydrocarbon interferences. Once inside the M501-TRS the sample gas is scrubbed of all naturally occurring SO<sub>2</sub>, then passed through a special quartz converter which heats the gas to a very high temperature causing it to react with the O<sub>2</sub> present in the sample gas creating SO<sub>2</sub> in the following manner .

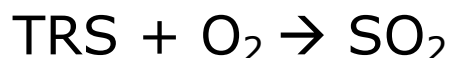

(Equation 9-1)

The converter is most efficient when it operates at 1000°C, converting >95% of the TRS into SO<sub>2</sub>. Converter temperature is viewable via the front panel of the M501-TRS

When the converter is operating at peak efficiency there is a nearly 1:1 relationship between the amount of TRS entering the converter and the amount of SO<sub>2</sub> leaving it. Therefore, by measuring the amount of SO<sub>2</sub> in the gas after it leaves the converter, the amount of TRS originally present on the sample gas can be directly inferred.

#### 9.1.2. SO<sub>2</sub> Ultraviolet Fluorescence

The physical principle upon which the M102E's measurement method is based is the fluorescence that occurs when sulfur dioxide (SO<sub>2</sub>) is excited by ultraviolet light with wavelengths in the range of 190 nm-230 nm. This reaction is a two-step process.

The first stage (Equation 9-2) occurs when SO<sub>2</sub> molecules are struck by photons of the appropriate ultraviolet wavelength. In the case of the Model 102E, a band pass filter between the source of the UV light and the affected gas limits the wavelength of the light to approximately 214

nm. The SO<sub>2</sub> molecules absorb some of the energy from the UV light causing one of the electrons of each of the affected molecules to move to a higher energy orbital state.

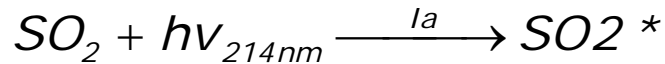

(Equation 9-2)

The amount of SO<sub>2</sub> converted to excited SO<sub>2</sub>\* in the sample chamber is dependent on the average intensity of the UV light (*Ia*) and not its peak intensity because the intensity of UV light is not constant in every part of the sample chamber. Some of the photons are absorbed by the SO<sub>2</sub> as the light travels through the sample gas.

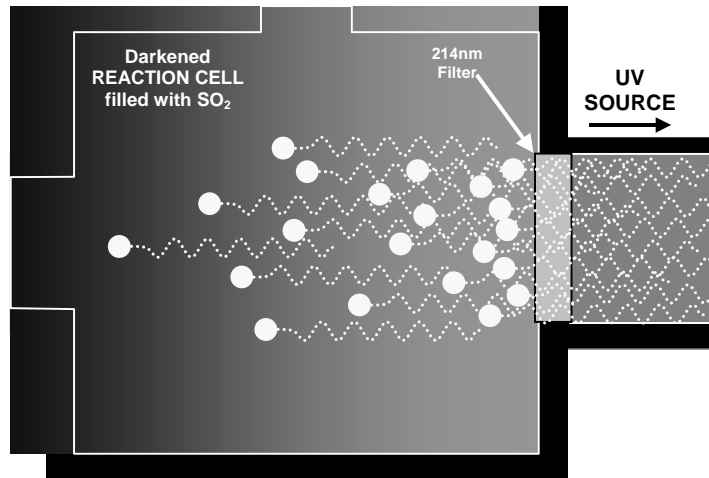

Figure 9-1: UV Absorption in the M102E Reaction Cell

The equation for defining the average intensity of the UV light (*Ia*) is:

$$Ia = I_0 [1 - \exp(-ax(SO_2))] ]$$

(Equation 9-3)

Where:

- I<sub>0</sub>*** = Intensity of the excitation UV light.
- a*** = The absorption coefficient of SO<sub>2</sub> (a constant).
- SO<sub>2</sub>*** = Concentration of SO<sub>2</sub> in the sample chamber.
- x*** = The distance between the UV source and the SO<sub>2</sub> molecule(s) being affected (path length).

The second stage of this reaction occurs after the SO<sub>2</sub> reaches its excited state (SO<sub>2</sub>\*). Because the system will seek the lowest available stable energy state, the SO<sub>2</sub>\* molecule quickly returns to its ground state (Equation 10-3) by giving off the excess energy in the form of a photon (*hν*). The wavelength of this fluoresced light is also in the ultraviolet band but at a longer (lower energy) wavelength centered at 330nm.

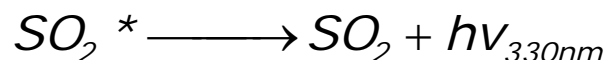

(Equation 9-4)

The amount of detectable UV given off by the decay of the  $SO_2^*$  is affected by the rate at which this reaction occurs ( $k$ ).

$$F = k(SO_2^*)$$

(Equation 9-5)

Where:

- $F$  = the amount of fluorescent light given off.  
 $k$  = The rate at which the  $SO_2^*$  decays into  $SO_2$ .  
 $SO_2^*$  = Amount of excited  $SO_2$  in the sample chamber.

So:

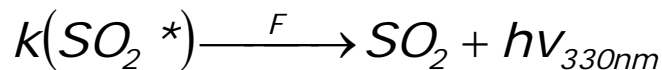

(Equation 9-6)

Finally, the function ( $k$ ) is affected by the temperature of the gas. The warmer the gas, the faster the individual molecules decay back into their ground state and the more photons of UV light are given off per unit of time.

In summary, given that the absorption rate of  $SO_2$  ( $a$ ) is constant, the amount of fluorescence ( $F$ ) is a result of:

- The amount of excited  $SO_2^*$  created which is affected by the variable factors from equation 10-2 above: concentration of  $SO_2$ ; intensity of UV light ( $I_0$ ); path length of the UV light ( $x$ ) and;
- The amount of fluorescent light created which is affected by the variable factors from equation 10-5: the amount of  $SO_2^*$  present and the rate of decay ( $k$ ) which changes based on the temperature of the gas.

So, when the intensity of the light ( $I_0$ ) is known; path length of excited light is short ( $x$ ); the temperature of the gas is known and compensated for so that the rate of  $SO_2^*$  decay is constant ( $k$ ); and; no interfering conditions are present (such as interfering gases or stray light); the amount of fluorescent light emitted ( $F$ ) is directly related to the concentration of the  $SO_2$  in the Sample Chamber.

The Model 100 E UV Fluorescence  $SO_2$  Analyzer is specifically designed to create these circumstances.

- The light path is very short ( $x$ ).
- A reference detector measures the intensity of the available excitation UV light and is used to remove effects of lamp drift ( $I_0$ ).
- The temperature of the sample gas is measured and controlled via heaters attached to the sample chamber so that the rate of decay ( $k$ ) is constant.
- A special hydrocarbon scrubber removes the most common interfering gases from the sample gas.
- And finally, the design of the sample chamber reduces the effects of stray light via its optical geometry and spectral filtering.

The net result is that any variation in UV fluorescence can be directly attributed to changes in the concentration of  $SO_2$  in the sample gas.

## 9.2. The UV Light Path

The following information is in addition to that contained in Section 10.2 of the M101E Manual - P/N 04740 Rev A.

### 9.2.1. UV Lamp Shutter & PMT Offset

Inherent in the operation of both the reference detector and the PMT are minor electronic offsets. The degree of offset differs from detector to detector and from PMT to PMT and can change over time as these components age.

To account for these offsets the M102E includes a shutter, located between the UV Lamp and the source filter, that periodically cuts off the UV light from the sample chamber. This happens every 30 minutes. The analyzer records the outputs of both the reference detector and the PMT during this dark period and factors them into the SO<sub>2</sub> concentration calculation.

- The reference detector offset is stored as and viewable via the front panel as the test function **DRK LMP**.
- The PMT offset is stored as and viewable via the front panel as the test function **DRK PMT**

## 9.3. Pneumatic Operation

### 9.3.1. Sample gas Flow

See Figures 3-4, 4-1 and 4-2 for depictions of the internal pneumatic flow of both the M102E & the M501-TRS.

### 9.3.2. M501 SO<sub>2</sub> Scrubber

In order to ensure that no ambient SO<sub>2</sub> interferes with the analyzer's TRS measurement the sample gas stream is passed through a chemical scrubber that removes SO<sub>2</sub> from the sample stream before it is passed through the M501-TRS converter oven.

The SO<sub>2</sub> scrubber is a Teflon encased, stand-alone unit containing a room-temperature catalyst tube mounted in the right side of the converter case (see Figure 3.2).

The SO<sub>2</sub> scrubber material is consumed as it removes SO<sub>2</sub>. If the expected concentrations of SO<sub>2</sub> are very high, the lifetime of the scrubber will be short. The expected life of the scrubber is approximately 1000 ppm-hours. See Section 8.1.1.3 for information on when and how to replace the SO<sub>2</sub> scrubber material)

## 9.4. Electronic Operation

### 9.4.1. Sensor Module

This Section replaces Section 10.4.2 of the M101E Manual - P/N 04740 Rev A.

Electronically, the M102E sensor module is a group of components that: create the UV light that initiates the fluorescence reaction between  $\text{SO}_2$  and  $\text{O}_3$ ; sense the intensity of that fluorescence and generate various electronic signals needed by the analyzer to determine the  $\text{SO}_2$  concentration of the sample gas (see Section 9.1) and sense and control key environmental conditions such as the temperature of the sample gas and the PMT.

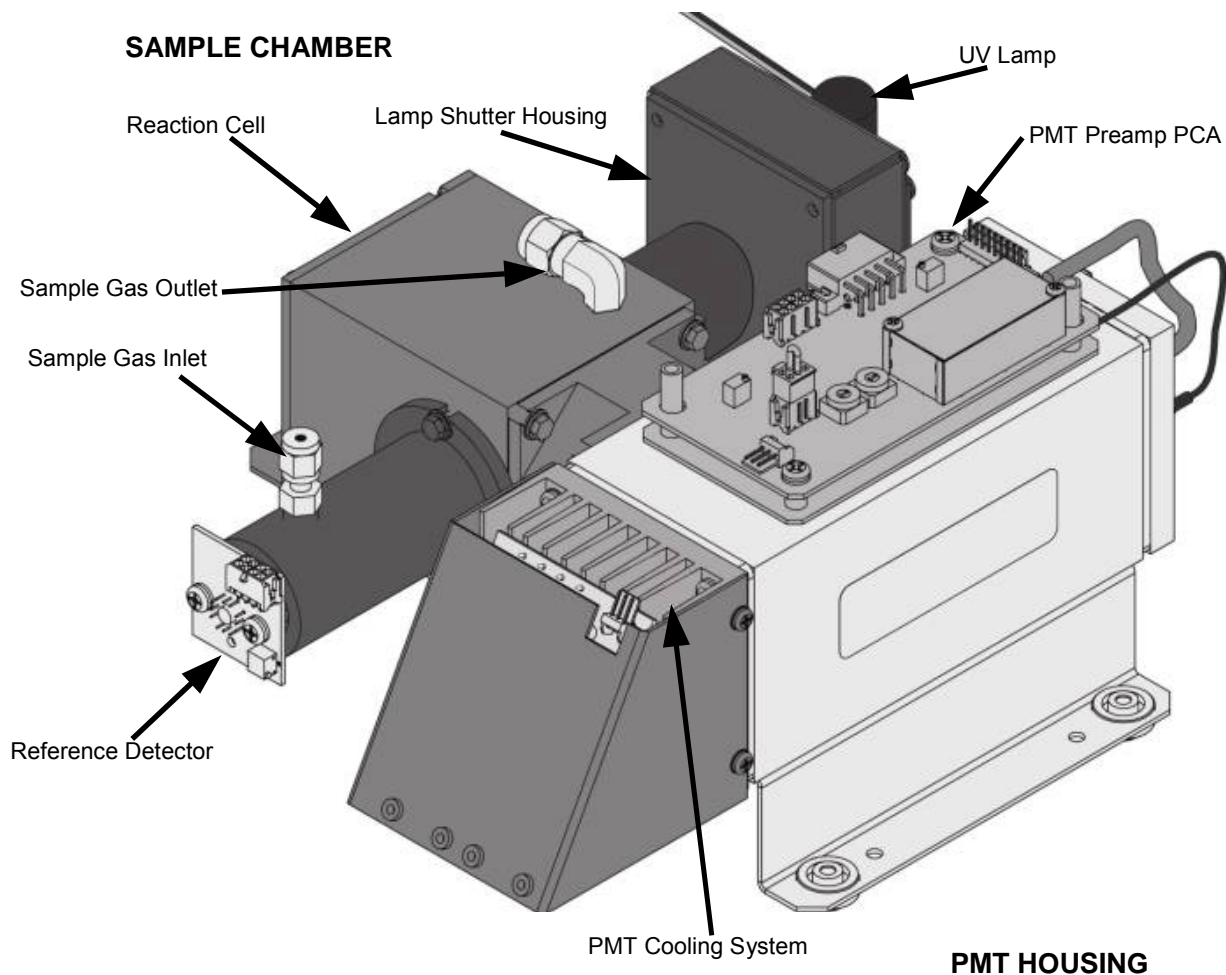

Figure 9-2: M102E Sensor Module

These components are divided into two significant subassemblies. The sample chamber and the PMT assembly.

- Figure 9-3 shows an exploded view of the sample chamber assembly
- Figure 9-5 shows an exploded view of the PMT Assembly

### 9.4.1.1. Sample Chamber

The main electronic components of the sample chamber are the reference detector (see Section 10.2.2 of the M101E Manual - P/N 04740 Rev A); the UV Lamp (see Section 10.2.1 of the M101E Manual - P/N 04740 Rev A) and its electronically operated shutter (see Section 9.2.1 of this addendum); and the sample chamber heating circuit,

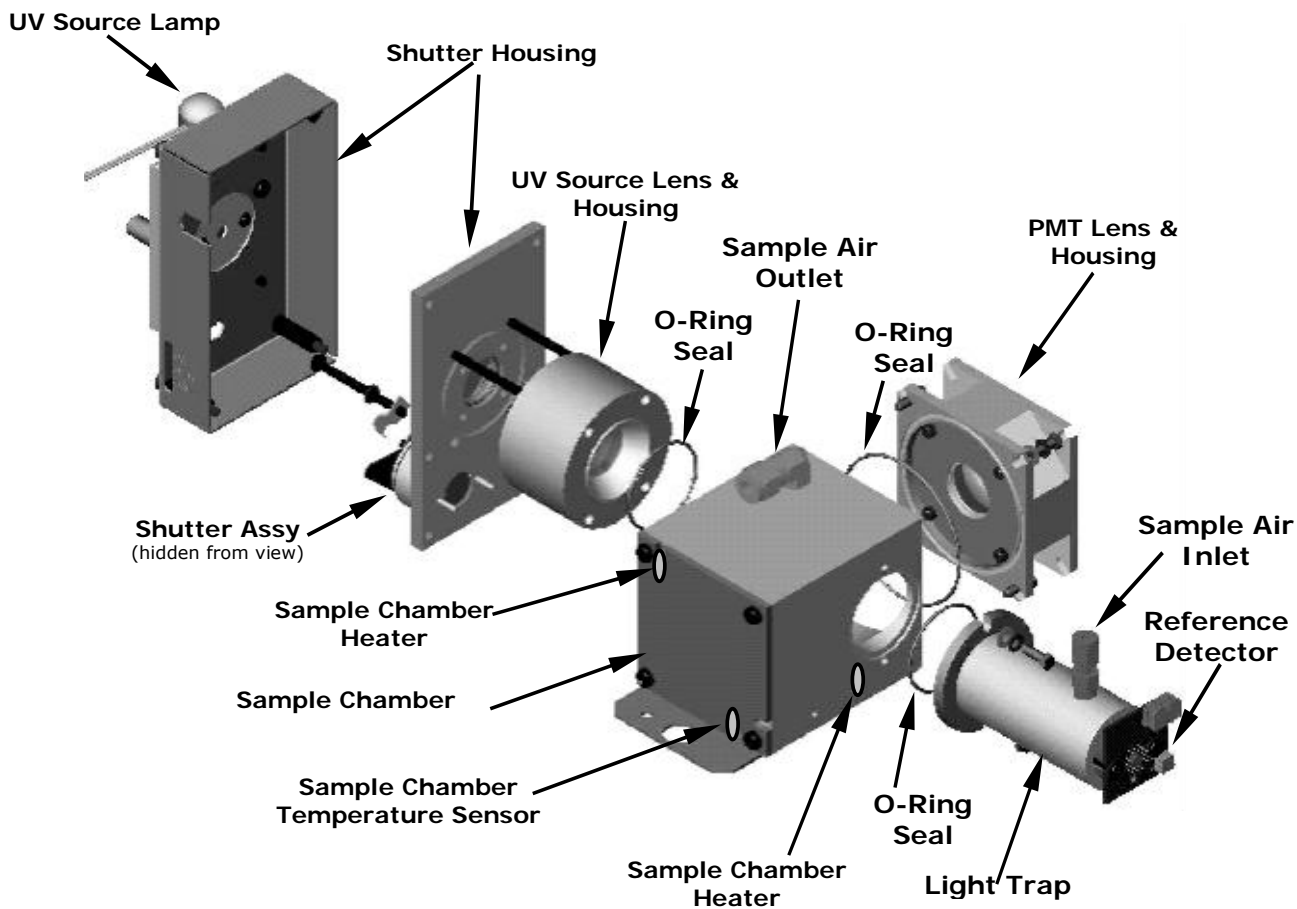

Figure 9-3: M102E Sample Chamber

### 9.4.1.2. Sample Chamber Heating Circuit

In order to reduce temperature effects, the sample chamber is maintained at a constant 50°C, just above the high end of the instrument's operation temperature range. Two AC heaters, one embedded into the top of the sample chamber, the other embedded directly below the reference detector's light trap, provide the heat source. These heaters operate off of the instrument's main AC power and are controlled by the CPU through a power relay on the relay board. A thermistor, also embedded in the bottom of the sample chamber, reports the cell's temperature to the CPU through the thermistor interface circuitry of the motherboard.

## 9.4.2. M501-TRS electronics

Electronically the M501-TRS is a simple device. The nucleus of the instrument is a programmable, P-I-D temperature controller which manages the temperature of the instruments' AC powered converter oven based on analog input from K-type thermocouple attached to the converters chamber.

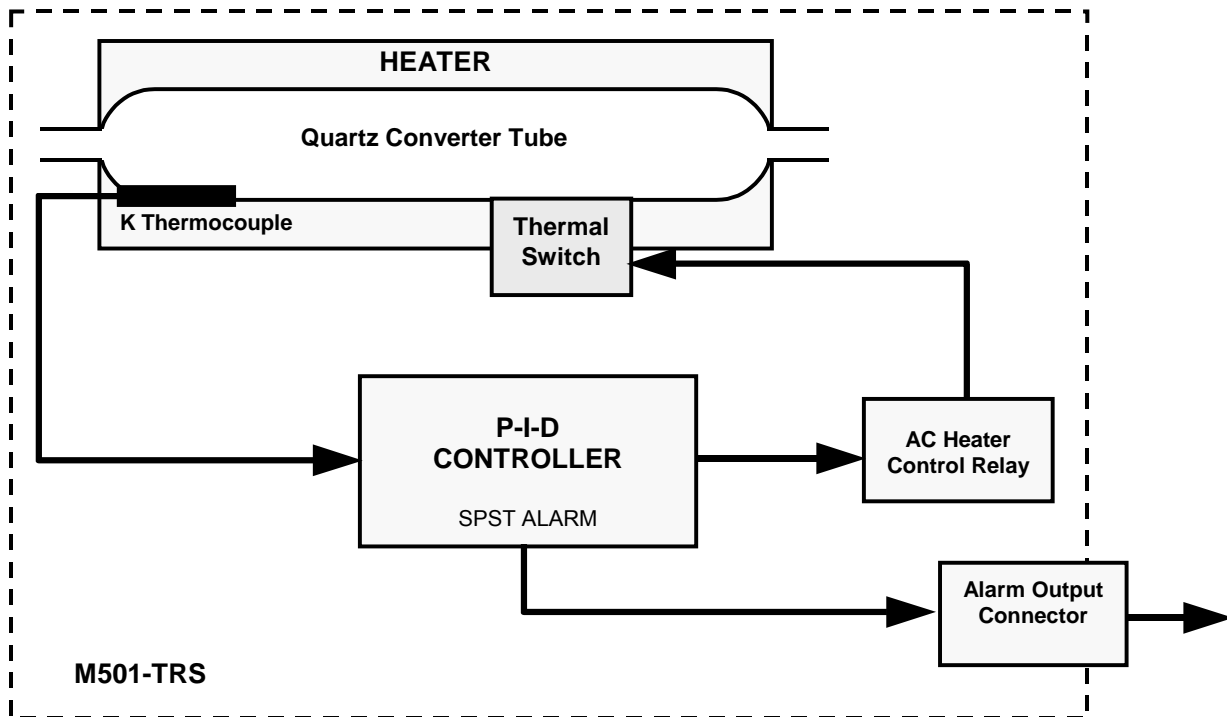

Figure 9-4: M501-TRS Electronic Block Diagram

The P-I-D controller determines the differences between the actual temperature of the oven (called the process value or PV), compares it to the target temperature (called the set point or SV) and changes the percentage of time the heater is turned on versus the time it is turned off accordingly. The higher the proportion of ON-time versus OFF-time the faster the oven is heated. For instance, if the PV is much lower than the SV the P-I-D will keep the heater turned on 100% of the time resulting in a relatively rapid increase in the temperature of the oven. As the PV approaches the same temperature as the SV the ON cycles get shorter compared to the OFF cycles.

The M501-TRS's P-I-D controller includes sophisticated software that allows the controller to track the rate change in temperature of the oven compared to the percentage of heater ON-time and predict the proportion needed to reach and maintain the proper oven temperature with a minimal amount of overshoot or fluctuation.

### 9.4.2.1. Thermal Switch

While the M501-TRS's P-I-D Controller includes many safeguards that prevent runaway heating of the converter oven, as an additional safety backup the M501-TRS includes a heat sensitive switch which automatically interrupts power to the heater if before the oven temperature reaches critical levels.

#### 9.4.2.2. Temperature Alarms and Alarm Output

The M501-TRS' controller has two user settable alarm points: High Alarm and Low Alarm. A single SPST alarm output is triggered should the PV rise above the set level of the high alarm point or fall below the level of the low alarm point.

The relay is normally open, and the contact closes in the alarm condition. The relay contacts are isolated (dry) SPST, 220VAC / 30 VDC 1 Amp, resistive load. This alarm output is available via a connector on the rear panel of the M501-TRS.

The M501-TRS temperature controller is programmed to hold off activation of either alarm until after the process value rises above the lower limit for the first time after power up.

---

## User Notes:



## 10. TROUBLESHOOTING & REPAIR

This section includes various troubleshooting and repair information that is either in addition to that included in Chapter 11 of the M101E Manual (P/N 04740 Rev A)

	<p><b>CAUTION</b></p> <p>The operations outlined in this chapter must be performed by qualified maintenance personnel only.</p> <p>Please read Chapter 11 of the M101E Manual (P/N 04740 Rev A) before attempting the following trouble shooting or repair procedures</p>
---	---

	<p><b>CAUTION</b></p> <p>Risk of electrical shock. Some operations need to be carried out with the analyzer open and running. Exercise caution to avoid electrical shocks and electrostatic or mechanical damage to the analyzer. Do not drop tools into the analyzer or leave those after your procedures. Do not shorten or touch electric connections with metallic tools while operating inside the analyzer. Use common sense when operating inside a running analyzer.</p>
---	--

### 10.1.1. Fault Diagnosis with Warning Messages

#### 10.1.1.1. M102E Warning Messages

The warning messages for the M102E are identical to those included in Section 11.1.1 of the M101E Manual (P/N 04740 Rev A) except that there is no **CONV TEMP WARNING**.

#### 10.1.1.2. M501-TRS Error Codes

The following error codes may appear on the temperature controller display of the M501-TRS

**Table 10-1: Test Functions - Possible Causes for Out-Of-Range Values**

ERROR MESSAGE	CAUSE	NOTES
UUUU	Thermocouple burnt out or wiring between Thermocouple and Temperature Controller is open. The controller process value exceeds the upper input range set point by 5% of full scale.	Controller will automatically turn off the converter heater and allow the TRS converter to cool down. <ul style="list-style-type: none"> <li>• Check the thermocouple for shorts or opens.</li> <li>• Check the condition of the wiring between the thermocouple and the controller.</li> </ul>
LLLL	When the controller process value is below the lower input range set point by 5% of full scale.	
Err	When either the Upper or lower limit of the input range is set improperly (e.g. Upper limit is set to lower value than lower limit).	Controller will turn off heating element until error is corrected.
FAL7	Undefined fault in controller	<b>Turn off M501-TRS. Call Teledyne Instruments Customer Service.</b>

## 10.1.2. Fault Diagnosis with Test Functions

The Following table supercedes Table 11.2 of the M101E Manual - P/N 04740 Rev A.

**Table 10-2: Test Functions - Possible Causes for Out-Of-Range Values**

TEST FUNCTION	NOMINAL VALUE(S)	POSSIBLE CAUSE(S)
STABIL	≤1 ppb with zero air	Faults that cause high stability values are: pneumatic leak; low or very unstable UV lamp output; light leak; faulty HVPS; defective preamp board; aging PMT; PMT recently exposed to room light; dirty/contaminated reaction cell.
SAMPLE FL	650 cm <sup>3</sup> /min ± 10%	Faults can be caused by: clogged critical flow orifice; pneumatic leak; faulty flow sensor; sample line flow restriction.
PMT	-20 TO 150 mV with zero air	High or noisy readings could be due to: calibration error; pneumatic leak; light leak (improper assembly); aging UV filter; low UV reference output; PMT recently exposed to room light; light leak in reaction cell; reaction cell contaminated; HVPS problem. <i>It takes 24-48 hours for a PMT exposed to ambient light levels to return to normal functioning.</i>
NORM PMT	- -	Noisy Norm PMT value (assuming unchanging SO <sub>2</sub> concentration of sample gas): Calibration error; HVPS problem; PMT problem; UV reference problem; UV lamp problem.
UV LAMP	2000 -4000 mV	This is the instantaneous reading of the UV lamp intensity. Low UV lamp intensity could be due to: aging UV lamp; UV lamp position out of alignment; faulty lamp transformer; aging or faulty UV detector; dirty optical components. Intensity lower than 600 mV will cause <b>UV LAMP WARNING</b> .
LAMP RATIO	30 TO 120%	The current output of the UV reference detector divided by the reading stored in the CPU's memory from the last time a UV Lamp calibration was performed. Out of range lamp ratio could be due to: malfunctioning UV lamp; UV lamp position out of alignment; faulty lamp transformer; aging or faulty UV detector; dirty optical components; pin holes or scratches in the UV optical filters; light leaks.
STR LGT	40-100 ppb	High stray light could be caused by: aging UV filter; contaminated reaction cell; light leak; pneumatic leak.
DRK PMT	-50 - +200 mV	High dark PMT reading could be due to: light leak; shutter not closing completely; high pmt temperature; high electronic offset.
DRK LMP	-50 - +200 mV	High dark UV detector could be caused by: light leak; shutter not closing completely; high electronic offset.
HVPS	≈ 400 V to 900 V	Incorrect HVPS reading could be caused by; HVPS broken; preamp board circuit problems.
RCELL TEMP	50°C ± 1°C	Incorrect temperature reading could be caused by: malfunctioning heater; relay board communication (I <sup>2</sup> C bus); relay burnt out
BOX TEMP	ambient + ~ 5°C	Incorrect temperature reading could be caused by: Environment out of temperature operating range; broken thermistor; runaway heater
PMT TEMP	7°C ± 2°C constant	Incorrect temperature reading could be caused by: TEC cooling circuit broken; High chassis temperature; 12V power supply
IZS TEMP (OPTION)	50°C ± 1°C	Malfunctioning heater; relay board communication (I <sup>2</sup> C bus); relay burnt out
PRESS	ambient ± 2 IN-HG-A	Incorrect SAMPLE pressure could be due to: pneumatic leak; malfunctioning valve; malfunctioning pump; clogged flow orifices; sample inlet overpressure; faulty pressure sensor
SLOPE	1.0 ± 0.3	Slope out of range could be due to: poor calibration quality ; span gas concentration incorrect; leaks; UV Lamp output decay.
OFFSET	< 250 mV	High offset could be due to: incorrect span gas concentration/contaminated zero air/leak; low-level calibration off; light leak; aging UV filter; contaminated reaction cell; pneumatic leak.
TIME OF DAY	Current time	Incorrect Time could be caused by: Internal clock drifting; move across time zones; daylight savings time?

## 10.2. M501-TRS Trouble shooting

### 10.2.1. TRS Converter Not Heating:

Problems with heating the If the TRS converter oven can have several causes.

- The "UUUU" error code will is displayed on the M501-TRS temperature controller display indicating a problem with the thermocouple
  - Check the resistance across the thermocouple leads for opens or shorts.
  - Check to make sure that the thermocouple leads are securely connected to the wiring block at the back of the controller.
  - Make sure that the wiring block/socket is correctly plugged onto socket on the back pf the controller.
- The set point for the process value is set incorrectly.
  - Check the set value; if it is incorrect, reset it.
- The controller is not in operational mode.
  - Press the PV/SV switch to return it to operation mode.
- The heater is malfunctioning.



#### CAUTION

**Make sure the M501-TRS is turned off and no AC power is being supplied to the heater before proceeding.**

- Check the resistance across the heater coil. It should be approximately 16.5 ohms.
- Check the wiring between the heater and the power supply.
- Check to make sure the M501-TRS cooling fan is operating properly and that the instrument is properly ventilated. Poor ventilation can cause the M501-TRS' thermal switch to turn off the converter to prevent overheating.
- Check to make sure that the thermal switch and heater control relay are operating properly.

## 10.3. Other Performance Problems

### 10.3.1. Excessive noise

In addition to the causes listed in Section 11.4.1 of the M101E Manual (P/N 04740 Rev A), an excessively noisy TRS measurement can be caused by hysteresis or fluctuations in the temperature of the TRS converter oven in the M501-TRS. If this is the case, perform the autotune procedure described in Section 6.4. of this addendum.

## 10.4. Subsystem Checkout

In addition to the information contained in Section 11.5 of the M101E Manual - P/N 04740 Rev A, the following diagnostic procedures are useful for troubleshooting and diagnosing problems with your M102E and M501-TRS.

### 10.4.1. Checking the Efficiency of the M501-TRS SO<sub>2</sub> Scrubber

See Section 8.1.1.2 of this addendum

### 10.4.2. Checking the Efficiency of the M501-TRS TRS → SO<sub>2</sub> Converter

To check to see if your TRS → SO<sub>2</sub> converter is operating properly:

1. Set the analyzer to TRS measurement mode (see Section 6.8.1 of the M101E Manual - P/N 04740 Rev A).
2. Bypass the scrubber inside the M501-TRS.
  - a. Unscrew the pneumatic fittings from the scrubber.
  - b. Connect them with a stainless steel or Teflon<sup>®</sup> union.
3. Supply a gas with a known concentration of SO<sub>2</sub> to the sample gas inlet of the analyzer.
4. Wait until the analyzer's output concentration measurement stabilizes. This can be determined by setting the analyzer's display to show the **TRS STB** test function (see Section 6.2.1 of the M101E Manual - P/N 04740 Rev A) **TRS STB** should be **0.5 ppb** or less before proceeding.
5. Record the stable SO<sub>2</sub> concentration (Although the concentration is labeled TRS, we are measuring SO<sub>2</sub>)
6. Supply a gas with a concentration of H<sub>2</sub>S equal to that of the SO<sub>2</sub> gas used in steps 2 through 5 above, to the sample gas inlet of the analyzer.
7. Wait until the analyzer's output concentration measurement stabilizes. This can be determined by setting the analyzer's display to show the **TRS STB** test function (see Section 6.2.1) **TRS STB** should be **0.5 ppb** or less before proceeding.
8. Record the stable TRS concentration
9. Divide the TRS concentration by the SO<sub>2</sub> concentration

EXAMPLE: If the SO<sub>2</sub> and TRS concentration of the two test gases used is 500 ppb:

Measured SO<sub>2</sub> concentration = 499.1 ppb

Measured TRS concentration = 490.3 ppb

Converter Efficiency =  $490.3 \div 499.1$

Converter Efficiency = 0.982 (98.2%)

10. If TRS → SO<sub>2</sub> converter efficiency is below 90% check for one of the following possible causes:

- Pneumatic leak
  - Perform a leak check (with the M501-TRS connected) as described in Section 11.5.1 of the M101E Manual - P/N 04740 Rev A.
- Plugged or constricted pneumatic flow?
  - Perform a sample flow check as described in Section 11.5.2 of the M101E Manual - P/N 04740 Rev A. This tests the entire system
  - Disconnect the gas feed line from the **FROM ANALYZER** port of the M501-TRS. Attach the flow meter to the port and repeat the test. Isolates the portions of the pneumatic system down stream from the TRS → SO<sub>2</sub> switching valve but includes the M501-TRS in the flow test.
  - Attach the flow meter to the **FROM CONVERTER** port at the back of the M102E. Retest. This bypasses M501-TRS during the flow test.
- Improper Set point temperature. Call Teledyne API's customer service for advice.
- Span Gas used in efficiency test was incorrect/wrong concentration. Independently verify the concentration of the span gas.
- Contaminants in the converter chamber, pneumatic lines. Sometimes contaminants such as tiny particles of scrubber material from the M501-TRS' SO<sub>2</sub> scrubber can get into the converter tube and react with the TRS → SO<sub>2</sub> conversion process, if the inline filter after the scrubber was damaged..

Call Teledyne Instruments customer service for instructions on cleaning the converter tube and M501-TRS pneumatic lines.

## 10.5. Additional Repair Procedures

The following repair procedures are in addition to those listed in Section 11.6 of the M101E Manual - P/N 04740 Rev A,

### 10.5.1. UV Lamp Adjustment and/or Replacement

There are three ways in which ambient conditions can affect the UV Lamp output and therefore the accuracy of the TRS concentration measurement. These are:

**Line Voltage Change:** UV lamp energy is directly proportional to the line voltage. This can be avoided by installing adequate AC Line conditioning equipment such as a UPS/surge suppressor.

**Lamp Aging** - Over a period of months, the UV energy will show a downward trend, usually 30% - 50% in the first 90 days, and then a slower rate, until the end of useful life of the lamp. Periodically running the UV lamp calibration routine (see Section 6.9.7 of the M101E Manual - P/N 04740 Rev A) will compensate for this until the lamp output becomes too low to function at all, 2-3 years nominally.

**Lamp Positioning** – The UV output level of the lamp is not even across the entire length of the lamp. Some portions of the lamp shine slightly more brightly than others. At the factory the position of the UV lamp is adjusted to optimize the amount of UV light shining through the UV filter/lens and into the reaction cell. Changes to the physical alignment of the lamp can affect the analyzer's ability to accurately measure SO<sub>2</sub>. See Section 11.6.3.2 of the M101E Manual (P/N 04740 Rev A) for instructions on adjusting the lamp position.

### 10.5.1.1. Adjusting the UV Lamp (*Peaking the Lamp*)



**CAUTION:**  
**ALWAYS wear UV-Protective, Safety Glasses when working with the UV Lamp Assembly**

1. Set the analyzer display to show the signal I/O function, **UVLAMP\_SIGNAL** (see Section 11.1.3 of the M101E Manual - P/N 04740 Rev A). **UVLAMP\_SIGNAL** is function 35.
2. Slightly loosen the large brass thumbscrew located on the shutter housing (see Figure 10-1) so that the lamp can be moved.
3. While watching the **UVLAMP\_SIGNAL** reading, slowly rotate the lamp or move it back and forth vertically until the **UVLAMP\_SIGNAL** reading is at its maximum.

**NOTE:**

**DO NOT grasp the UV lamp by its cap when changing its position (see Figure 10-1). Always grasp the main body of the lamp.**

- Ideally, the reading should be 3500mV±200mV.
  - If **UVLAMP\_SIGNAL** is lower than 600mV, replace the lamp.
  - If **UVLAMP\_SIGNAL** is greater than 3800 mV, adjust the pot on the UV reference board down until the output reads 3500 mV, and then continue to peak the lamp.
4. Finger tighten the thumbscrew.

**NOTE:**

**DO NOT over-tighten the thumbscrew.**

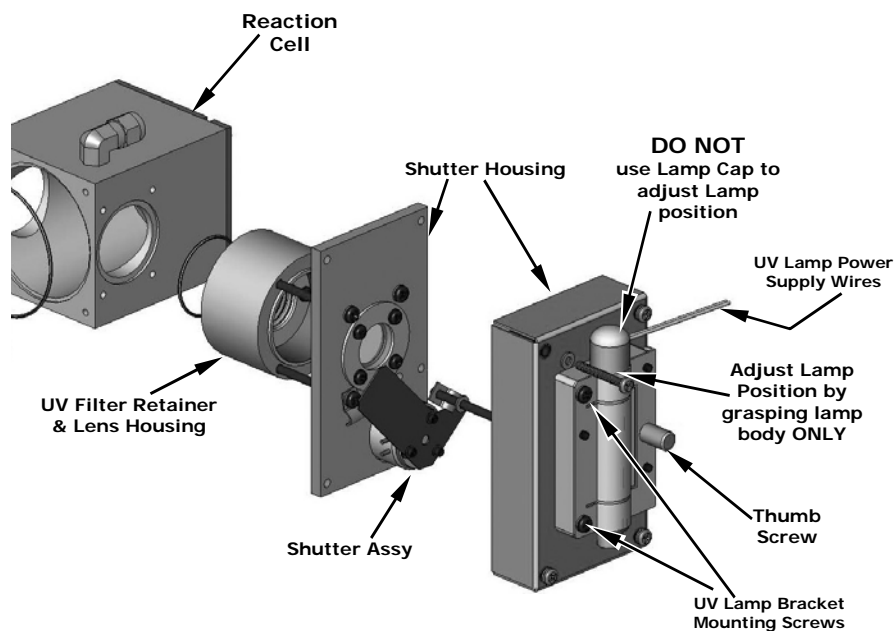

**Figure 10-1: Shutter Assembly - Exploded View**

### 10.5.1.2. Replacing the UV Lamp

1. Turn off the analyzer.
2. Disconnect the UV lamp from its power supply.
  - You can find the power supply connector by following the two, white UV Lamp power supply wires from the lamp to the power supply.
3. Loosen, but do not remove the two UV lamp bracket screws, and the large brass thumbscrew located on the shutter housing (see Figure 10-1) so that the lamp can be moved.

**NOTE:**

**DO NOT grasp the UV lamp by its cap when changing its position (see Figure 10-1). Always grasp the main body of the lamp.**

4. Remove the UV Lamp by pulling it straight up.
5. Insert the new UV lamp into the bracket.
6. Tighten the two UV lamp bracket screws, but leave the brass thumb screw un-tightened.
7. Connect the new UV lamp to the power supply.
8. Turn the instrument on and perform the UV adjustment procedure as defined in section 10.5.1.1 of this addendum

- Finger tighten the thumbscrew.

**NOTE:**

**DO NOT over-tighten the thumbscrew.**

- Perform a lamp calibration procedure (see Section 6.9.7 of the M101E Manual - P/N 04740 Rev A) and a zero point and span point calibration (see Chapter 7 of the M101E Manual - P/N 04740 Rev A).

### 10.5.2. Replacing the UV filter/lens

**Note:**

**Be careful not to leave thumbprints on the interior of the sample chamber. The various oils that make up fingerprints fluoresce brightly under UV light and will significantly affect the accuracy of the analyzer's SO<sub>2</sub> measurement)**

- Turn off the instrument's power and remove the power cord from the instrument.
- Unplug the J4 connector from the motherboard to allow tool access.
- Remove 4 screws from the shutter cover (see figure 11-2) and remove the cover .
- Remove 4 screws from the UV filter retainer.

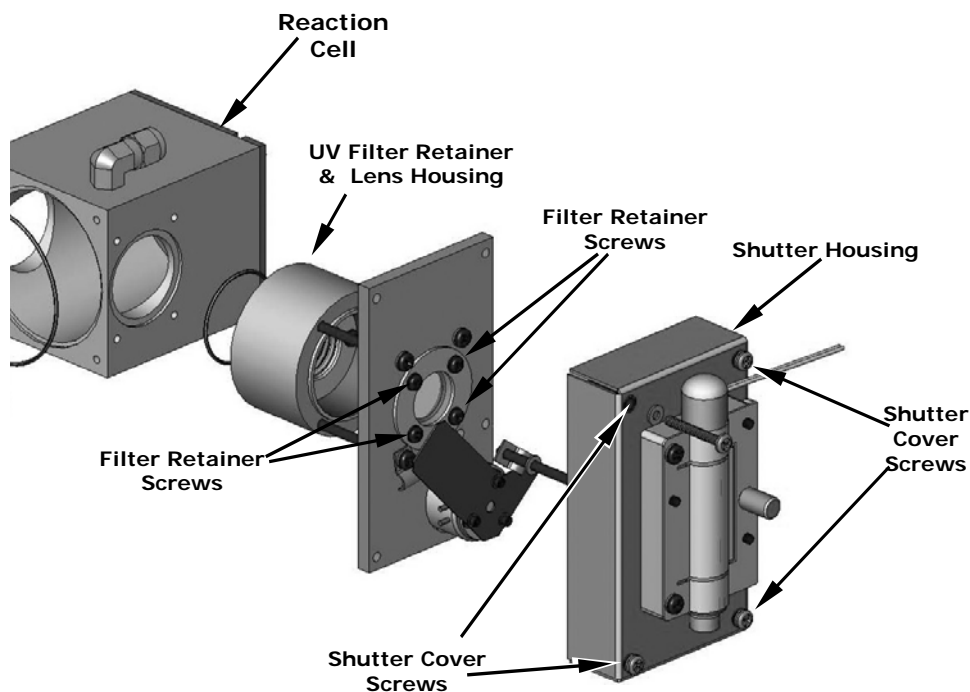
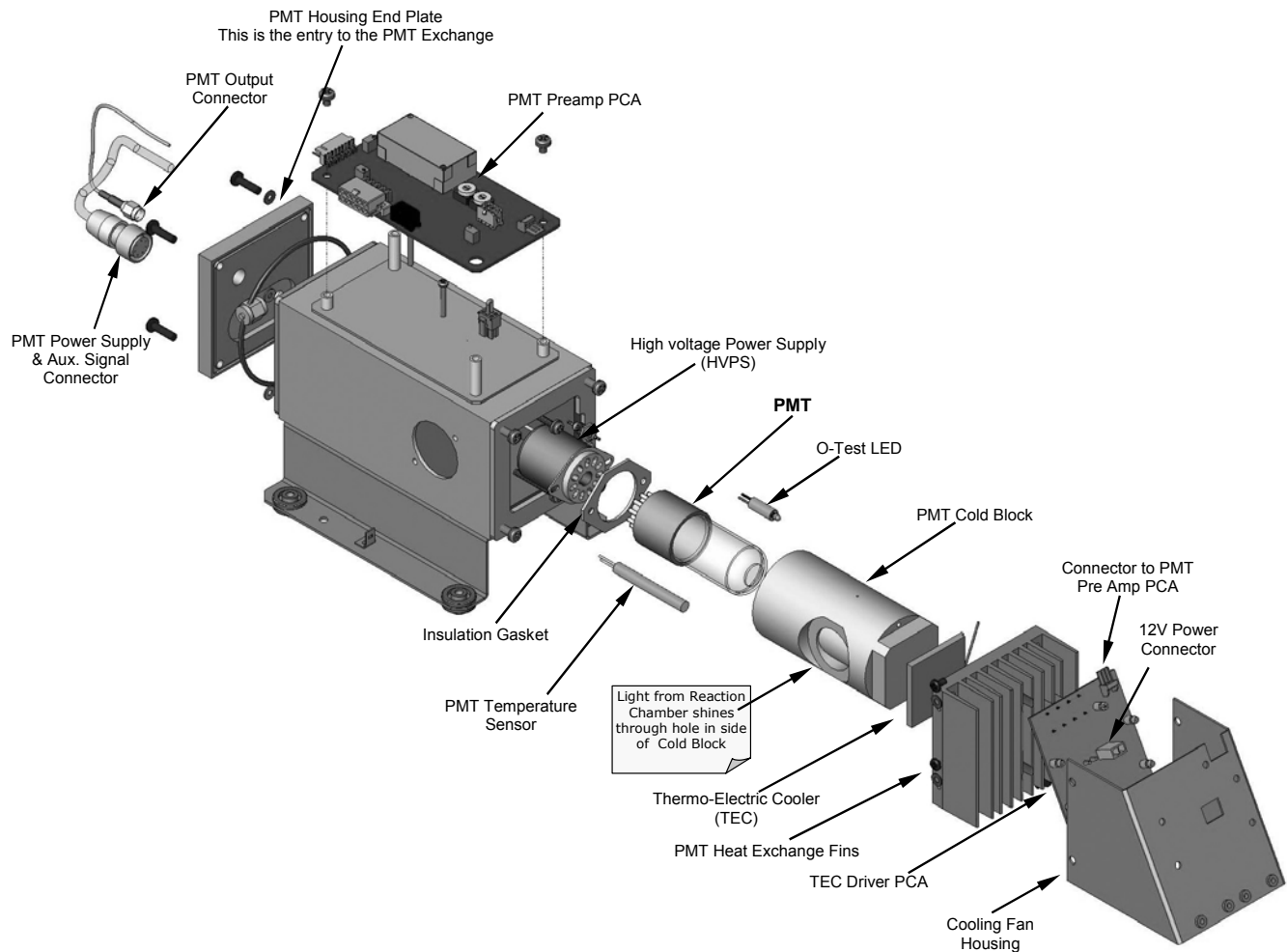

**Figure 10-2: Disassembling the Shutter Assembly**



- Carefully remove the UV filter.
- Install the UV filter. Handle carefully and never touch the filter's surface. The UV filter's wider ( ring ) side should be facing out. Install the UV filter retainer and tighten screws.
- Install the shutter cover and minifit connector. Tighten 4 screws.
- Re-plug J4 connector into the motherboard.

### 10.5.3. Replacing the PMT, HVPS or TEC



**Figure 10-3: PMT Assembly - Exploded View**

The PMT should last for the lifetime of the analyzer. However, in some cases, the high voltage power supply (HVPS) or the thermo-electric cooler (TEC) may fail. To replace the PMT, the HVPS or the TEC:

- Power down the analyzer, disconnect the power cord, remove the cover and disconnect all pneumatic and electrical connections from the sensor assembly.
- Remove the entire sensor module assembly from the.

3. Remove the reaction cell assembly.
4. Remove the two connectors on the PMT housing end plate facing towards the front panel.
5. Remove the end plate itself (4 screws with plastic washers). R
6. Remove all of the desiccant bags inside the PMT housing.
7. Along with the plate, slide out the OPTIC TEST LED and the thermistor that measures the PMT temperature.
  - The thermistor will be coated with a white, thermal conducting paste. Do not contaminate the inside of the housing or the PMT tube with this grease.
8. Unscrew the PMT assembly. It is held to the cold block by two plastic screws.
  - Because the threads of the plastic screws are easily damaged it is highly recommended to use new screws when reassembling the unit.
9. Carefully take out the assembly consisting of the HVPS, the gasket and the PMT.
10. Change the PMT or the HVPS or both, clean the PMT glass tube with a clean, anti-static wipe and do not touch it after cleaning.
11. If the cold block or TEC is to be changed disconnect the TEC driver board from the preamplifier board.
  - a. Remove the cooler fan duct (4 screws on its side) including the driver board.
  - b. Disconnect the driver board from the TEC and set the sub-assembly aside.
  - c. Remove the end plate with the cooling fins (4 screws) and slide out the PMT cold block assembly, which contains the TEC.
  - d. Unscrew the TEC from the cooling fins and the cold block and replace it with a new unit.
12. Re-assemble the TEC subassembly in reverse order.

**CAUTION**

**The thermo-electric cooler needs to be mounted flat to the heat sink. If there is any significant gap, the TEC might burn out. Make sure to apply heat sink paste before mounting it and tighten the screws evenly and cross-wise.**

- a. Make sure to use thermal grease between the TEC and the cooling fins as well as between the TEC and the cold block.
  - b. Align the side opening in the cold block with the hole in the PMT housing where the sample Chamber attaches.
  - c. Evenly tighten the long mounting screws for good thermal conductivity.
13. Re-insert the TEC subassembly. Make sure that the O-ring is placed properly and the assembly is tightened evenly.
  14. Insert the LED and thermistor into the cold bloc.

15. Re-insert the PMT/HVPS subassembly.
  - Don't forget the gasket between HVPS and PMT.
  - Use new plastic screws to mount the PMT assembly on the PMT cold block.
16. Insert the new desiccant bags.
17. Carefully replace the end plate.
  - Make sure that the O-ring is properly in place. Improperly placed O-rings will cause leaks, which – in turn – cause moisture to condense on the inside of the cooler causing the HVPS to short out.
18. Reconnect the cables and the reaction cell
  - Be sure to tighten these screws evenly,
19. Replace the sensor assembly into the chassis and fasten with four screws and washers.
20. Reconnect all electrical and pneumatic connections, leak check the system and power up the analyzer. Verify the basic operation of the analyzer using the ETEST and OTEST features (see Section 6.9.5 & 6.9.6 of the M101E Manual - P/N 04740 Rev A) or by measuring calibrated zero and span gases.
21. Perform a PMT Hardware calibration (see Section 11.6.6 of the M101E Manual - P/N 04740 Rev A)
22. Perform a zero point and span calibration (See Chapter 7 of the M101E Manual - P/N 04740 Rev A)

#### **10.5.4. M102E PMT Hardware Calibration (*FACTORY CAL*)**

**This procedure supercedes the one contained in section 11.6.3 of the M101E Manual - P/N 04740 Rev A.**

The sensor module hardware calibration adjusts the slope of the PMT output when the Instruments slope and offset values are outside of the acceptable range and all other more obvious causes for this problem have been eliminated.

1. Set the instrument reporting range to **SNGL** & 500 ppb (see Section 6.7.4 of the M101E Manual - P/N 04740 Rev A)
2. Perform a full zero–point calibration using zero air (see Chapter 7 of the M101E Manual - P/N 04740 Rev A).
3. Let the instrument stabilize by allowing it to run for one hour.
4. Adjust the UV Lamp. (See Section 10.5.1.1 of this addendum)
5. Perform a **LAMP CALIBRATION** procedure (see Section 6.9.7 of the M101E Manual - P/N 04740 Rev A).

6. Locate the Preamp board (see Figure 3-1).
7. Locate the Following Components On the Preamp board (see Figure 10-4):
  - HVPS coarse adjustment switch (Range 0-9, then A-F)
  - HVPS fine adjustment switch (Range 0-9, then A-F)
  - Gain adjustment potentiometer (Full scale is 10 to 12 turns).

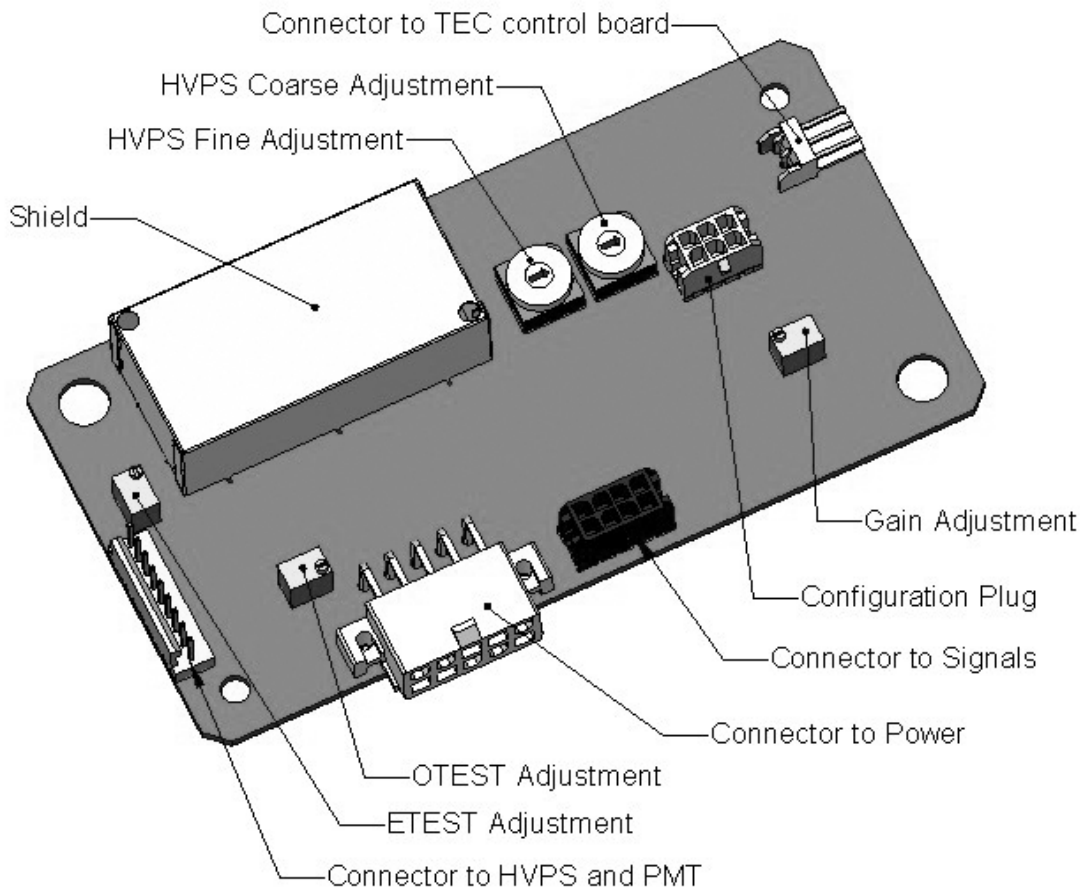

**Figure 10-4: Pre-Amplifier Board Layout**

8. Set the HVPS coarse adjustment to its minimum setting (0).
9. Set the HVPS fine adjustment switch to its maximum setting (F).
10. Turn the gain adjustment potentiometer clockwise to its maximum setting.
11. Set the front panel display to show **STABIL** (see Section 6.2.1 of the M101E Manual - P/N 04740 Rev A)
12. Feed 400 ppb span gas into the analyzer.

**NOTE**

If a reporting range other than 500 ppb is used in this procedure:

Use a span gas equal to 80% of the reporting range and adjust the PMT to a target NORM PMT value of twice the ppb value of the span gas.

**EXAMPLE**

If the reporting range is 800 ppb:

Use 640 ppb span gas.

Adjust the PMT until NORM PMT equals 1280 mV  $\pm$  10 mV

13. Wait until the **STABIL** value is below 0.5 ppb,
14. Scroll to the **NORM PMT** value.
15. Set the HVPS coarse adjustment switch to the lowest setting that will give you more than 1000 mV NORM PMT signal.
  - The coarse adjustment typically increments the **NORM PMT** signal in 100-300 mV steps.
16. Adjust the HVPS fine adjustment such that the **NORM PMT** value is at or just above 800 mV.

**NOTE**

**Do not overload the PMT by setting both adjustment switches to their maximum setting. This can cause permanent damage to the PMT.**

17. Continue adjusting the both the coarse and fine switches until **NORM PMT** is as close to 800 mV as possible.
18. Adjust the gain adjustment potentiometer until the NORM PMT value is 800 mV  $\pm$ 10 mV.
19. Perform span and zero-point calibrations (see Chapter 7 of the M101E Manual - P/N 04740 Rev A) to normalize the sensor response to its new PMT sensitivity.
20. Review the slope and offset values, and compare them to the values in Table 7-5 of the M101E Manual - P/N 04740 Rev A.

### 10.5.5. Replacing the TRS Converter Heating Tube



**WARNING !**

**THE CONVERTER TUBE AND HEATER ARE VERY HOT  
DO NOT TOUCH WHILE THE M501-TRS IS OPERATING**

1. Turn off the M501-TRS

2. Allow it to cool to room temperature. This may take up to 30 minutes.
3. Remove the instruments top cover (see Section 3.2 of this addendum)
4. Remove the four screws holding the converter cover in place.
5. Carefully lift the converter cover away.
6. Loosen front and rear pneumatic fittings at each end of the tube and remove the gas lines from the converter tube.
7. Remove the front ceramic bobbin from the converter tube. The thermistor assembly will come with it.

**NOTE:****Be Careful!**

**The ceramic bobbins at each end of the heater assembly are fragile.**

8. Slide a new tube into the heater coil assembly.
9. Make sure that the thermistor is threaded through its notch on the center hole of the front converter bobbin and properly seated in the corresponding indentation in the body of the quartz heater tube.
10. Reattach the front bobbin onto the converter tube.
11. Reattach the gas lines and retighten the pneumatic fittings.
12. Reassemble the converter cover and reattach the M501-TRS top cover.

**NOTE**

**The M501-TRS will not operate properly with the top cover removed.**

**The air cooling required to stabilize the temperature of the converter tube is dependent on air flow patterns that only exist with the top cover in place.**

**Without the top cover in place, the thermal cutout may overheat, and shut the heating element off.**

13. Restart the M501-TRS.
14. Check the converter efficiency. See Section 10.4.2 of this addendum.

## 10.6. Manually Programming the M501-TRS Temperature Controller

**NOTE**

**The temperature controller has been programmed at the factory and should not be altered, (except for temperature set point).**

**DO NOT manually alter the PID parameters of the M501-TRS temperature Controller unless directed to do so by Teledyne Instruments customer service personnel.**

In the event that the temperature controller of the M501-TRS must be replaced some initial programming is required set the control functions if reprogramming is necessary. The following tables define the approximate initial values for various processes control parameters. Once they are set, perform an autotune procedure as defined in Section 6.4 of this addendum

### 10.6.1. Temperature Controller Primary Menu Parameters

#### NOTE

Tables 10-3 and 10-4 show the typical primary P-I-D parameter values for operation on 115V/60Hz with a set value of 1000°C.

The P, I and d values may be different for other AC main voltages (call Teledyne Instruments customer service, and will vary somewhat after auto-tuning).

To set these parameters:

1. Open the appropriate menu
  - a. Press the SELECT key once to access the primary menu parameters. The main display will show **P**.
  - b. Press and Hold the SELECT key for 3 seconds to access the primary menu parameters. The main display will show **P-n I**.
2. Use the SELECT , DOWN or 100's UP key to scroll through the primary menu parameters until the appropriate parameter is displayed (see Table 10-3 or Table 10-4).
3. Press the DATA key once. The current value of the parameter will be displayed.
4. To set each digit:
  - a. Press the up-arrow under that digit once. The digit will flash.
  - b. To increment that digit, press and hold the digit until the appropriate number is displayed.
  - c. To decrement that digit press and hold the DOWN key until the appropriate number is displayed.
  - d. To increment/decrement the 1000's digit it is necessary to adjust increment/decrement the 100's digit up and down. Each time the 100's digit passes "0" the 1000s digit will increment or decrement correspondingly.
5. Once the desired value is reached, press the ENT key to store the new set Parameter value.
6. Press the PV/SV mode key to return to operational mode.

Table 10-3 – Temperature Controller – Primary Parameter Settings

DISPLAY	PARAMETER NAME	SET TO	COMMENTS
<b>P</b>	Proportional Band	<b>11</b>	Sets the bandwidth of the proportional control function to $\pm 11\%$ of full scale
<b>I</b>	Integral time	<b>10</b>	Sets the reaction time for the proportional control function to 10 seconds.
<b>d</b>	Derivative Time	<b>7.7</b>	Sets the reaction time for the derivative control function (which reduces overshoot) to 7.7 seconds.
<b>AL</b>	Low Alarm Limit	<b>950</b>	Sets the low alarm point to 950°C
<b>AH</b>	High Alarm Limit	<b>1050</b>	Sets the high alarm point to 1010°C
<b>TC</b>	Cycle Time	<b>2</b>	Sets the cycle time (which is divided proportionally between On and Off) for 2 seconds. EXAMPLE: for a duty cycle of 25% with a Cycle time of 2 seconds, the controller will turn the heater on for 0.5 seconds every 2 seconds
<b>HYS</b>	Hysteresis	<b>3</b>	Sets the bandwidth of the area around the set point where the controller will not try to change the process value (thereby inducing unnecessary fluctuations) to 3 % of full scale.
<b>AT</b>	Autotune	<b>0 (OFF)</b>	Autotune is OFF
<b>LoC</b>	Parameter Lock	Can be either <b>0</b> <b>1</b> <b>2</b>	All parameters are changeable All parameters are locked The set value can be changed but all other parameters are locked
Ignore any other parameters that may appear.			



**Table 10-4 – Temperature Controller – Primary Parameter Settings**

DISPLAY	PARAMETER NAME	SET TO	COMMENTS
<b>P-n1</b>	OFF	<b>0</b>	Sets the controller to reverse action (hotter temperatures = less heating; lower temperatures = more heating) and turns off the heater should the thermocouple input fail.
<b>P-n2</b>	Input type	<b>3</b>	K thermocouple
<b>P-dF</b>	Digital Filter	<b>5</b>	Sets the response time of the digital noise filter to 5 sec.
<b>P-SL</b>	Lower input range limit	<b>32</b>	Sets the lower end of the controller full scale bandwidth to 32°C
<b>P-SU</b>	Upper input range limit	<b>1100</b>	Sets the upper end of the controller full scale bandwidth to 1100°C
<b>P-AL</b>	High Alarm Type	<b>10</b>	Sets the High alarm point to trigger when the process value exceeds the high alarm set point only after the process value rises above the lower limit for the first time after power up
<b>P-AH</b>	Low Alarm Type	<b>10</b>	Sets the Low alarm point to trigger when the process value exceeds the high alarm set point only after the process value rises above the lower limit for the first time after power up
<b>P-An</b>	Alarm Hysteresis	<b>3</b>	Sets the hysteresis bandwidth for both alarm points to 3% of full scale.
<b>P-dP</b>	Decimal Point	<b>0</b>	Sets the decimal point for PV & SV readings to NONE
<b>PUOF</b>	Process variable Offset	<b>0</b>	OFF
<b>SUOF</b>	Set variable Offset	<b>0</b>	OFF
<b>P-f</b>	Celsius/Fahrenheit	<b>C</b>	Sets controller to perform function on Celsius temperature scale.
<b>FUSy</b>	Fuzzy Logic	<b>ON</b>	Turns of the controllers advanced fuzz logic feature which further reduces overshoot and fluctuations.
Ignore any other parameters that may appear.			

## 10.7. Technical Assistance

If this addendum and its trouble-shooting / repair sections do not solve your problems, technical assistance may be obtained from Teledyne Instruments, Customer Service, 6565 Nancy Ridge Drive, San Diego, CA 92121. Phone: +1 858 657 9800 or 1-800 324 5190. Fax: +1 858 657 9816. Email: [api-customerservice@teledyne.com](mailto:api-customerservice@teledyne.com).

Before you contact customer service, fill out the problem report form in Appendix C, which is also available online for electronic submission at <http://www.teledyne-api.com/forms/index.asp>.

## User Notes:

## **APPENDIX A - Version Specific Software Documentation**

### **APPENDIX A-1: Model 102E Software Menu Trees**

**NOTE**

The menu tree structure for the M102E is nearly identical to that of the M101E.

Included here are menu trees, including some minor variations for:

- Basic Sample Display Menu
- Sample Display Menu for Units with Z/S Valve or IZS Option installed
  - HESSEN Submenu
  - DIAG Submenu

The following menu trees can be found in  
**Appendix A-1 of the M101E Manual - P/N 04740110 Rev A:**

- Primary Setup Menu
  - iDAS submenu
- Basic Secondary Setup Menu
  - COMM submenu
  - COMM submenu with Ethernet card installed
  - VARs submenu

**APPENDIX A-2: Model 102E Setup Variables Available Via Serial I/O**

**APPENDIX A-3: Model 102E Warnings and Test Measurements Via Serial I/O**

**APPENDIX A-4: Model 102E Signal I/O Definitions**

**APPENDIX A-5: Model 102E iDAS Functions**

APPENDIX A-1: M102E Software Menu Trees, Revision A.2

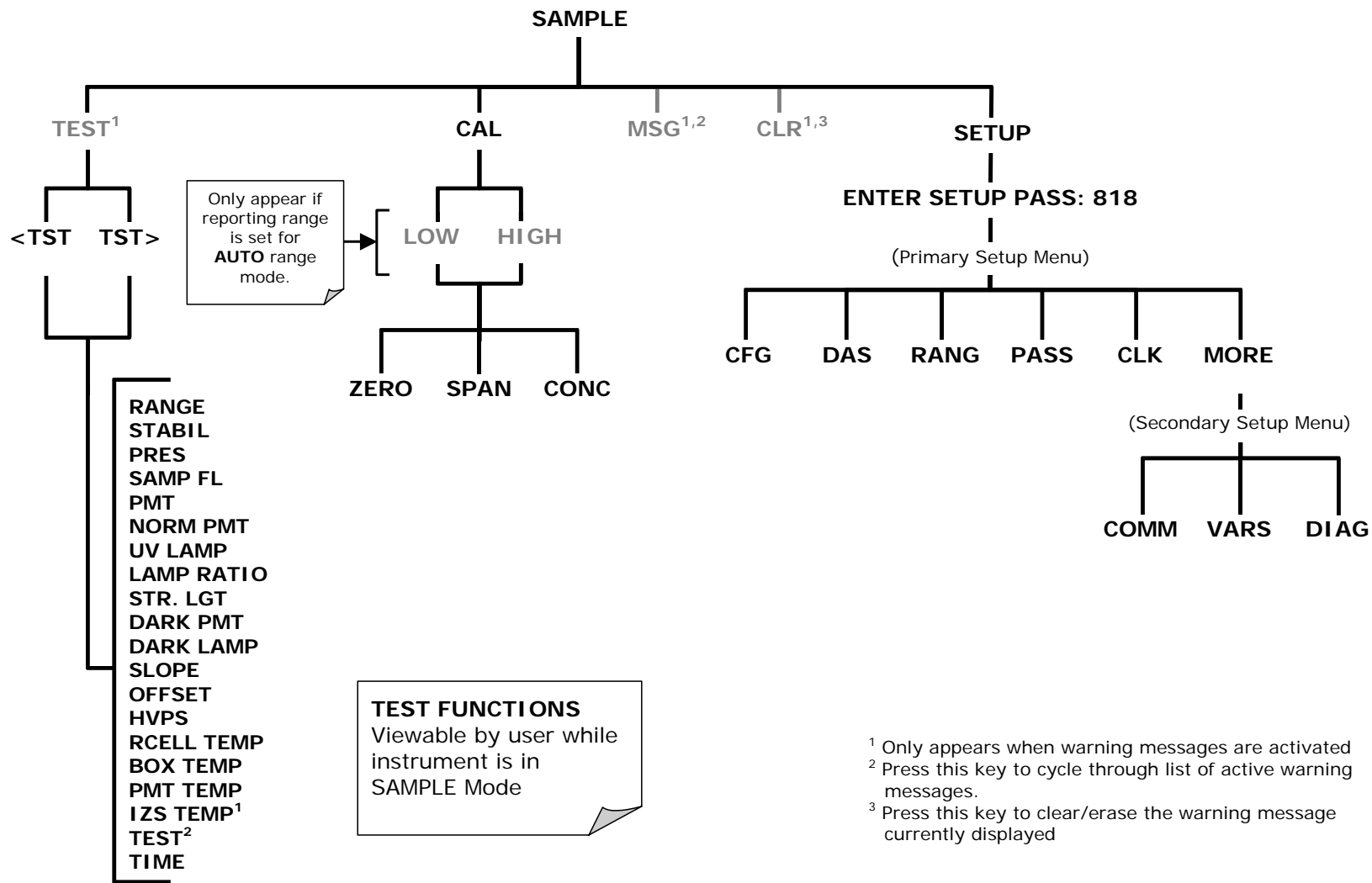

Figure A-1: Basic Sample Display Menu

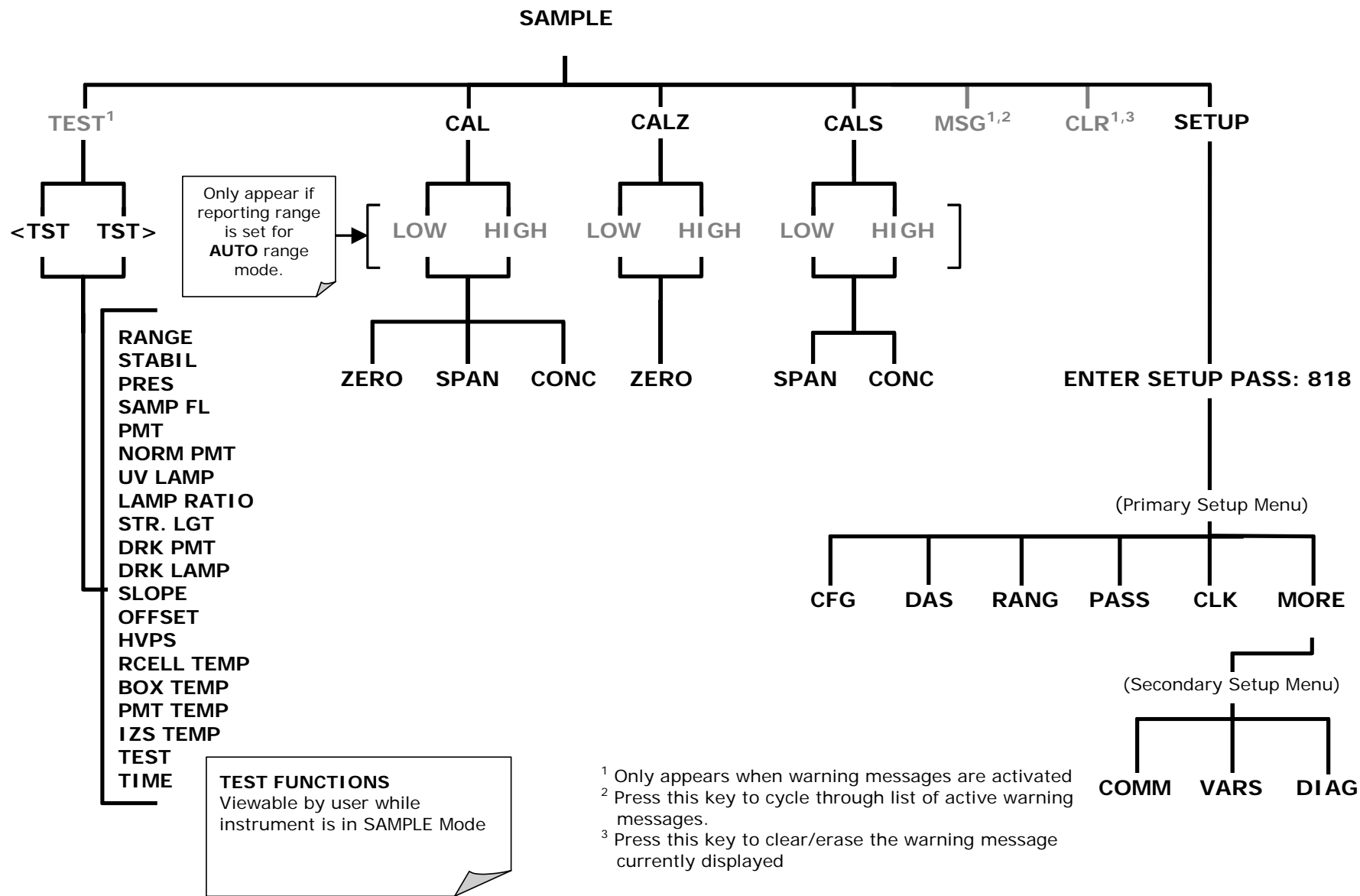
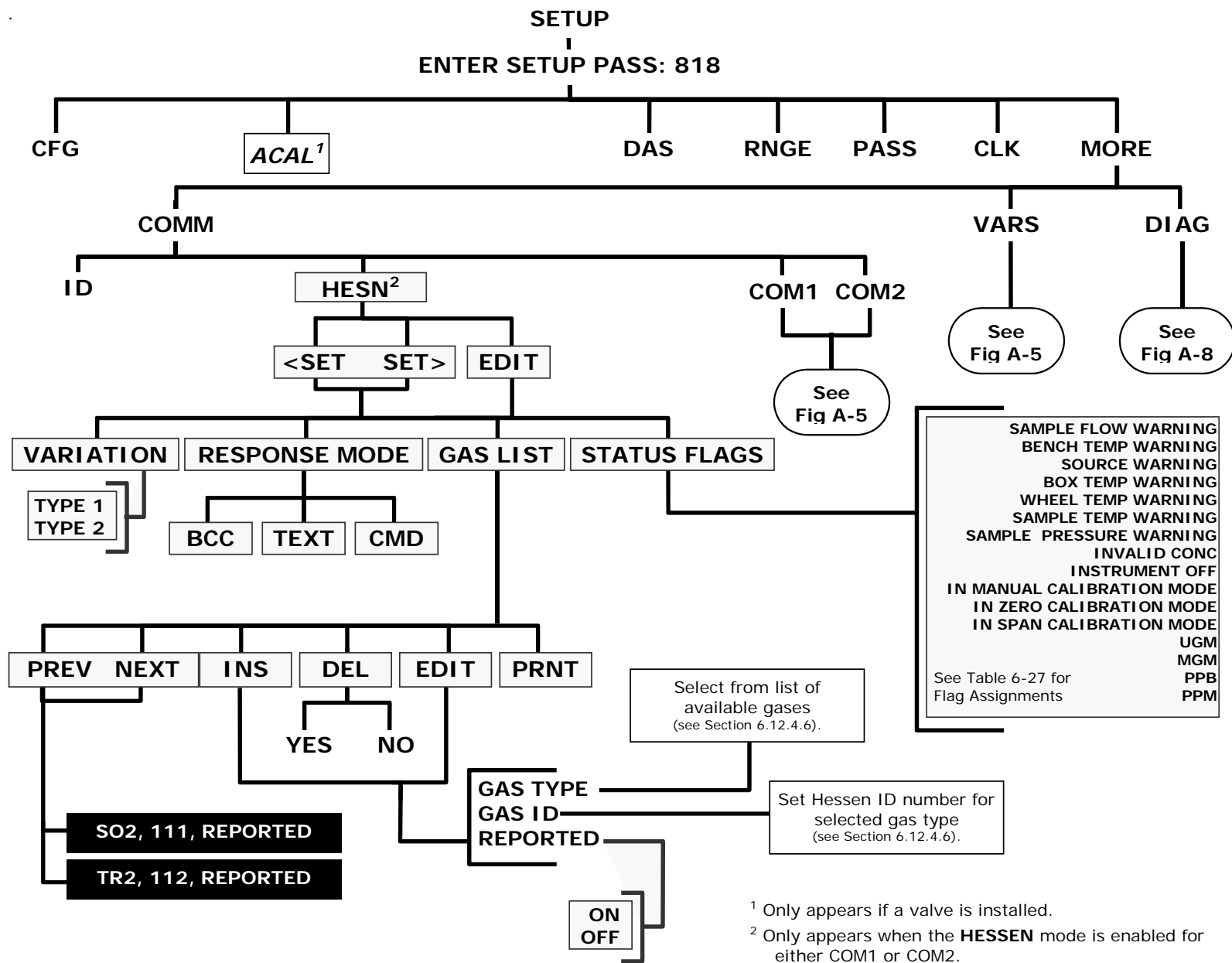

Figure A-2: Sample Display Menu - Units with Z/S Valve or IZS Option installed



<sup>1</sup> Only appears if a valve is installed.  
<sup>2</sup> Only appears when the **HESSEN** mode is enabled for either COM1 or COM2.

Figure A-3: Secondary Setup Menu - HESSEN Submenu

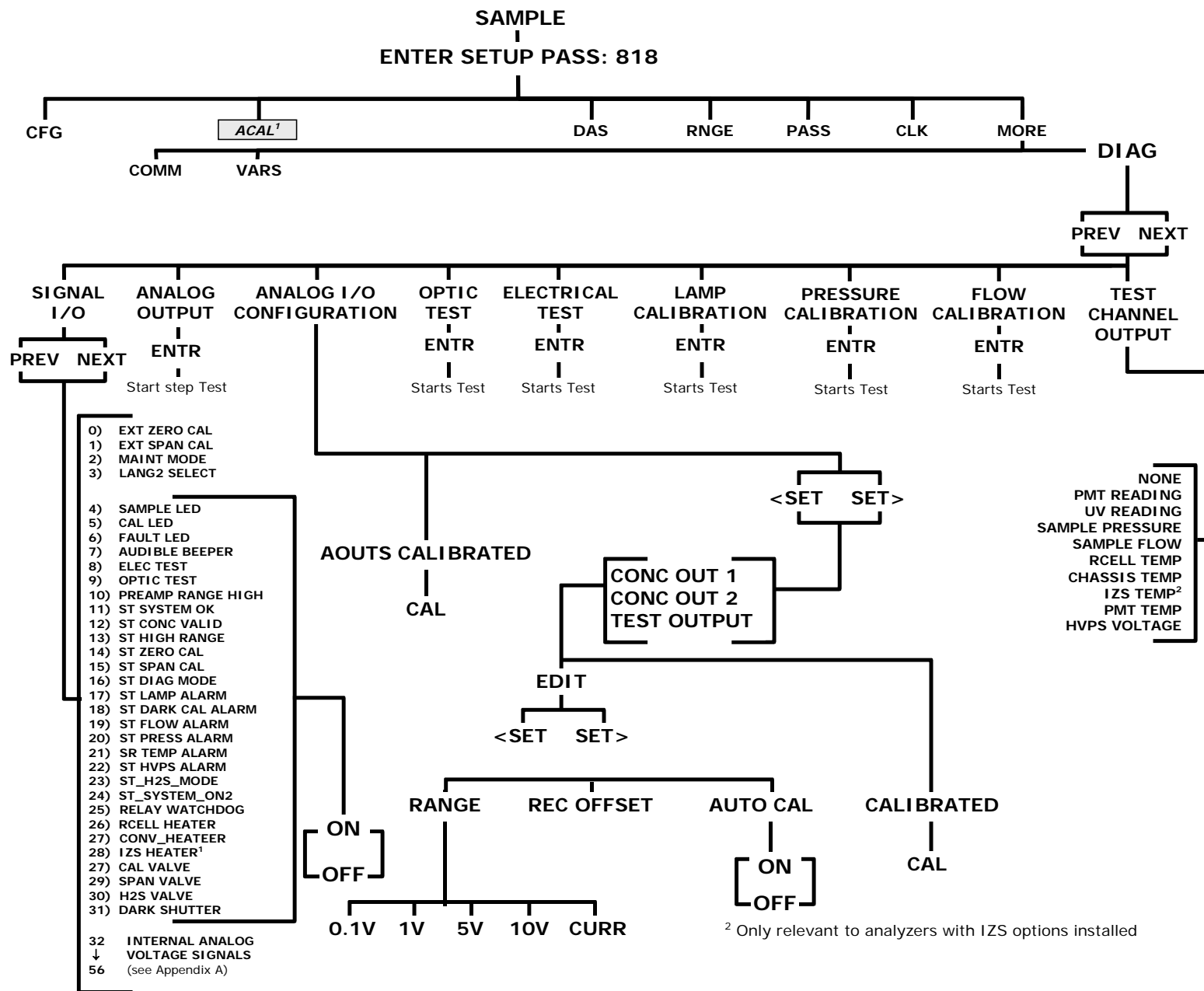

Figure A-4: Secondary Setup Menu (DIAG)

## APPENDIX A-2: Setup Variables For Serial I/O, Revision A.2

## NOTE

Setup Variables for the M102E are the same as those for the M101E (see Appendix A-3 of the M101E Manual - P/N 04740110 Rev A) with the following exceptions:

Table A-1: Changed or added Setup Variables for M102E Software Revision A.2

SETUP VARIABLE	NUMERIC UNITS	DEFAULT VALUE	VALUE RANGE	DESCRIPTION
MEASURE_MODE	—	SO2-TRS	SO2, SO2-TRS, TRS	Gas measurement mode. Enclose value in double quotes (") when setting from the RS-232 interface.
TRS_SPAN1	Conc	400	0.1–50000	Target TRS concentration during span calibration of range 1.
TRS_SPAN2	Conc	400	0.1–50000	Target TRS concentration during span calibration of range 2.
TRS_SLOPE1	PPB/mV	1	0.25–4	TRS slope for range 1.
TRS_SLOPE2	PPB/mV	1	0.25–4	TRS slope for range 2.
TRS_OFFSET1	mV	0	-1500–1500	TRS offset for range 1.
TRS_OFFSET2	mV	0	-1500–1500	TRS offset for range 2.
CE_FACTOR1	—	1	0.8–1.2	Converter efficiency factor for TRS for range 1.
CE_FACTOR2	—	1	0.8–1.2	Converter efficiency factor for TRS for range 2.
REMOTE_CAL_MODE	—	SO2-LOW	SO2-LOW, SO2-HIGH, TRS-LOW, TRS-HIGH	Gas and range to calibrate during contact-closure and Hessen calibration. Enclose value in double quotes (") when setting from the RS-232 interface.
STABIL_GAS	—	SO2	SO2, TRS	Gas to use to measure concentration stability. Enclose value in double quotes (") when setting from the RS-232 interface.

Table A-2: Deleted Setup Variables for M102E Software Revision A.2

SETUP VARIABLE	NUMERIC UNITS	DEFAULT VALUE	VALUE RANGE	DESCRIPTION
CONV_TYPE <sup>2</sup>	—	MOLY	NONE, MOLY	Converter type.
CONV_SET <sup>2</sup>	°C	315 Warnings: 310–320	0–350	Converter temperature set point and warning limits.
TEST_CHAN_ID	—	NONE	CONV TEMP ,	All other Test Channel settings are the same as those listed in appendix A-1 of the M101E Manual - P/N 04740110 Rev A



## APPENDIX A-3: Warnings and Test Functions, Revision A.2

## NOTE

Warning messages and test functions for the M102E are the same as those for the M102E (see Appendix A-3 of the M101E Manual - P/N 04740110 Rev A) with the following exceptions:

Table A-4: Warning Messages deleted from M102 Software Revision A.2

NAME	MESSAGE TEXT	DESCRIPTION
WCONVTEMP	CONV TEMP WARNING	Converter temperature outside of warning limits specified by <i>CONV_SET</i> variable.

Table A-5: Test Functions Changed and Added to M102 Software Revision A.2

TEST Function	Message Text	DESCRIPTION
STABILITY	TRS STB <sup>1</sup> =0.0 PPB <sup>1</sup>	Concentration stability (standard deviation based on setting of <i>STABIL_FREQ</i> and <i>STABIL_SAMPLES</i> ).
SO <sub>2</sub> SLOPE	SO2 SLOPE <sup>2</sup> =1.061	Slope for current SO <sub>2</sub> measurement range, computed during zero/span calibration.
SO <sub>2</sub> OFFSET	SO2 OFFS <sup>2</sup> =250.0 MV	Offset for current TRS measurement range, computed during zero/span calibration.
TRS SLOPE	TRS SLOPE <sup>2</sup> =1.061	Slope for current SO <sub>2</sub> measurement range, computed during zero/span calibration.
TRS OFFSET	TRS OFFS <sup>2</sup> =250.0 MV	Offset for current TRS measurement range, computed during zero/span calibration.

<sup>1</sup> Shown as it appear when analyzer is in TRS mode. In SO<sub>2</sub> mode appear as **SO2 STB**. In multigas mode, both versions appear.

<sup>2</sup> Only Appears in SO<sub>2</sub> and multigas measurement modes.

<sup>2</sup> Only Appears in TRS and multigas measurement mode.

Table A-6: Test Functions Deleted from M102 Software Revision A.2

TEST Function	Message Text	DESCRIPTION
RESPONSE <sup>2</sup>	RSP=1.11(0.00) SEC	Instrument response. Length of each signal processing loop. Time in parenthesis is standard deviation.
VACUUM <sup>5</sup>	VAC=9.1 IN-HG-A	Vacuum pressure.
RCELLDUTY	RCELL ON=0.00 SEC	Sample chamber temperature control duty cycle.
IZSDUTY	IZS ON=0.00 SEC	IZS temperature control duty cycle.
CONVTEMP	CONV TEMP=315.0 C	TRS → SO <sub>2</sub> Converter temperature.

## APPENDIX A-4: M102E Signal I/O Definitions, Revision A.2

## NOTE

Signal I/O Definitions for the M102E are the same as those for the M102E (see Appendix A-4 of the M101E Manual - P/N 04740110 Rev A) with the following exceptions:

Table A-7: Signal I/O Definitions Deleted from M102 Software Revision A.2

SIGNAL NAME	BIT OR CHANNEL NUMBER	DESCRIPTION
<b>Control inputs, U11, J1004, pins 1–6 = bits 0–5, default I/O address 321 hex</b>		
EXT_LOW_SPAN	2	0 = go into low span calibration 1 = exit low span calibration
<b>Relay board digital output (PCF8575), default I<sup>2</sup>C address 44 hex</b>		
CONV_HEATER	2	0 = converter cell heater on 1 = off
LOW_SPAN_VALVE	8	0 = let low span gas in 1 = let sample gas in
ZERO_VALVE	9	0 = let zero gas in 1 = let sample gas in
Rear board primary MUX analog inputs		
VACUUM_PRESSURE	10	Vacuum pressure

**APPENDIX A-5: M102E iDAS Functions, Revision A.2****NOTE**

iDAS Trigger Events and functions for the M102E are the same as those for the M102E (see Appendix A-5 and A-6 of the M101E Manual - P/N 04740110 Rev A) with the following exceptions:

**Table A-8: iDAS Trigger Events & Functions Deleted from M102 Software Revision A.2**

<b>TYPE</b>	<b>NAME</b>	<b>DESCRIPTION</b>
Trigger Event	<b>CTEMPW</b>	Converter temperature warning
Function	<b>CNVTMP</b>	Converter temperature

---

**User Notes:**



## APPENDIX B - M102E Spare Parts List

**NOTE**

Spare parts for the M102E are the same as those for the M101E (see Appendix B of the M101E Manual - P/N 04740120 Rev A)

Spare parts available for the M501-TRS are as follows:

**Table B-1: M102E Spare Parts List**

<b>PART NUMBER</b>	<b>DESCRIPTION</b>	<b>NOTES</b>
CH0000017	SO <sub>2</sub> scrubber refill	
000002125	Glass TRS converter tube	



Company: \_\_\_\_\_ Contact Name: \_\_\_\_\_

Phone Number: \_\_\_\_\_ Fax Number: \_\_\_\_\_ Email: \_\_\_\_\_

Site Address: \_\_\_\_\_

Can we connect to the instrument? If so, provide IP address or modem #: \_\_\_\_\_

Model 102E Serial Number: \_\_\_\_\_ Firmware revision: \_\_\_\_\_

The serial number can be found on the back of the instrument, the firmware revision is displayed in the upper left corner of the display when pressing SETUP on the front panel (Example: C.3).

1. List all front panel error/warning messages: \_\_\_\_\_

2. Please complete the following table: (Depending on options installed, not all test parameters shown below may be available in your instrument)

PARAMETER	RECORDED VALUE	ACCEPTABLE VALUE	PARAMETER	RECORDED VALUE	ACCEPTABLE VALUE
<b>RANGE</b>	ppb/ppm	50 ppb - 20 ppm	<b>SO2 SLOPE</b>		1.0 ± 0.3
<b>SO2 STB</b>	ppb	≤ 1 ppb with zero air	<b>TRS SLOPE</b>		1.0 ± 0.3
<b>TRS STB</b>	ppb	≤ 1 ppb with zero air	<b>SO2 OFFS</b>	mV	< 250
<b>SAMP FL</b>	cm <sup>3</sup> /min	500 ± 50	<b>TRS OFFS</b>	mV	< 250
<b>PMT signal with zero air</b>	mV	-20 to 150	<b>HVPS</b>	V	5500-900
<b>PMT signal at span gas conc</b>	mV ppb/ppm	0-5000 0-20 000 ppb	<b>ETEST</b>	mV	2000 ± 1000
<b>NORM PMT at span gas conc</b>	mV ppb/ppm	0-5000 0-20 000 ppb	<b>OTEST</b>	mV	2000 ± 1000
<b>UV LAMP</b>	mV	2 000 to 4 000	<b>RCELL TEMP</b>	°C	50 ± 1
<b>STR. LGT</b>	ppm	≤ 100 ppb/ zero air	<b>BOX TEMP</b>	°C	Ambient + ~5
<b>DARK PMT</b>	mV	-50 to 200	<b>PMT TEMP</b>	°C	7 ± 2
<b>DARK LAMP</b>	mV	-50 to 200	<b>IZS TEMP</b>	°C	50 ± 3

3. Has the analyzer been checked for leaks? Yes  No  For proper flows? Yes  No

4. What are the failure symptoms? \_\_\_\_\_

\_\_\_\_\_ Continue on back if necessary

5. Which tests have you done trying to solve the problem? \_\_\_\_\_

\_\_\_\_\_ Continue on back if necessary

6. If possible, fax a portion of a strip chart or email a data file to customer service.

CUSTOMER SERVICE CONTACT INFORMATION: 6565 Nancy Ridge Drive, San Diego, CA 92121.  
**PHONE:** +1 858 657 9800 or 1-800 324 5190. **FAX:** +1 858 657 9816. **EMAIL:** api-customerservice@teledyne.com.

You can access and submit an online version of this form at <http://www.teledyne-api.com/forms/csforM102E.asp>





## **APPENDIX D - ELECTRONIC SCHEMATICS**

The following drawing(s) are relevant to the M501-TRS.

All drawings relevant to the M102E are listed in Appendix D of the M101E Manual.

**Table D-1: List of Included Electronic Schematics**

<b>DOCUMENT #</b>	<b>DOCUMENT TITLE</b>
03404	Diagram, Cabling, M501TS Converter

---

## **USER NOTES:**

## User Notes

## Free Manuals Download Website

<http://myh66.com>

<http://usermanuals.us>

<http://www.somanuals.com>

<http://www.4manuals.cc>

<http://www.manual-lib.com>

<http://www.404manual.com>

<http://www.luxmanual.com>

<http://aubethermostatmanual.com>

Golf course search by state

<http://golfingnear.com>

Email search by domain

<http://emailbydomain.com>

Auto manuals search

<http://auto.somanuals.com>

TV manuals search

<http://tv.somanuals.com>