

USER INSTRUCTIONS

BKP-4, TKP-4, AND WKP-4 KEYPANELS

ADAM™, ADAM™ CS, AND ZEUS™ INTERCOM SYSTEMS

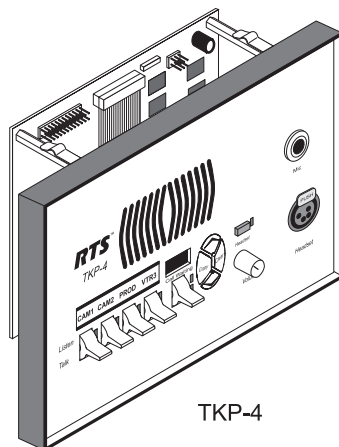
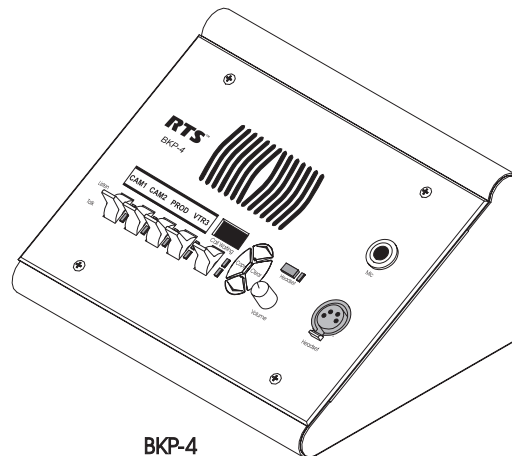
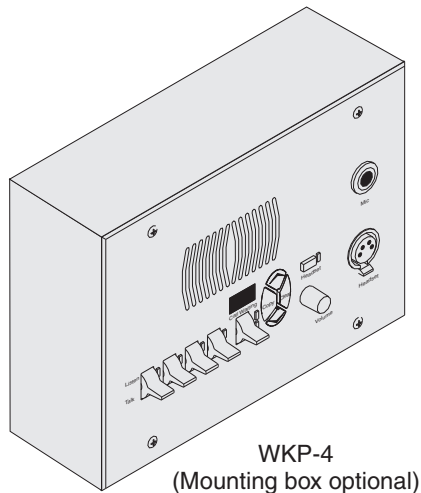

RTS™

PROPRIETARY NOTICE

The RTS product information and design disclosed herein were originated by and are the property of Telex Communications, Inc. Telex reserves all patent, proprietary design, manufacturing, reproduction, use and sales rights thereto, and to any article disclosed therein, except to the extent rights are expressly granted to others.

COPYRIGHT NOTICE

Copyright 1999 by Telex Communications, Inc. All rights reserved. Reproduction in whole or in part without prior written permission from Telex is prohibited.

UNPACKING AND INSPECTION

Immediately upon receipt of the equipment, inspect the shipping container and the contents carefully for any discrepancies or damage. Should there be any, notify the freight company and the dealer at once.

WARRANTY INFORMATION

RTS products are warranted by Telex Communications, Inc. to be free from defects in materials and workmanship for a period of three years from the date of sale.

The sole obligation of Telex during the warranty period is to provide, without charge, parts and labor necessary to remedy covered defects appearing in products returned prepaid to Telex. This warranty does not cover any defect, malfunction or failure caused beyond the control of Telex, including unreasonable or negligent operation, abuse, accident, failure to follow instructions in the Service Manual or the User Manual, defective or improper associated equipment, attempts at modification and repair not authorized by Telex, and shipping damage. Products with their serial numbers removed or effaced are not covered by this warranty.

To obtain warranty service, follow the procedures entitled "Procedure For Returns" and "Shipping to Manufacturer for Repair or Adjustment".

This warranty is the sole and exclusive express warranty given with respect to RTS products. It is the responsibility of the user to determine before purchase that this product is suitable for the user's intended purpose.

ANY AND ALL IMPLIED WARRANTIES, INCLUDING THE IMPLIED WARRANTY OF MERCHANTABILITY ARE LIMITED TO THE DURATION OF THIS EXPRESS LIMITED WARRANTY.

NEITHER TELEX NOR THE DEALER WHO SELLS RTS PRODUCTS IS LIABLE FOR INCIDENTAL OR CONSEQUENTIAL DAMAGES OF ANY KIND.

CUSTOMER SUPPORT

Technical questions should be directed to:

Customer Service Department
RTS/Telex,
12000 Portland Avenue South
Burnsville, MN 55337 U.S.A.
Telephone: (952) 884-4051
Fax: (800) 323-0498

RETURN SHIPPING INSTRUCTIONS

PROCEDURE FOR RETURNS

If a repair is necessary, contact the dealer where this unit was purchased.

If repair through the dealer is not possible, obtain a RETURN AUTHORIZATION from:

Customer Service Department
Telex Communications, Inc.
Telephone: (877) 863-4169
Fax: (800) 323-0498

DO NOT RETURN ANY EQUIPMENT DIRECTLY TO THE FACTORY WITHOUT FIRST OBTAINING A RETURN AUTHORIZATION.

Be prepared to provide the company name, address, phone number, a person to contact regarding the repair, the type and quantity of equipment, a description of the problem and the serial number(s).

SHIPPING TO MANUFACTURER FOR REPAIR OR ADJUSTMENT

All shipments of RTS products should be made via United Parcel Service or the best available shipper, prepaid. The equipment should be shipped in the original packing carton; if that is not available, use any suitable container that is rigid and of adequate size. If a substitute container is used, the equipment should be wrapped in paper and surrounded with at least four inches of excelsior or similar shock-absorbing material. All shipments must be sent to the following address and must include the Return Authorization.

Factory Service Department
Telex Communications, Incorporated
West 1st Street
Blue Earth, MN 56013 U.S.A.

Upon completion of any repair the equipment will be returned via United Parcel Service or specified shipper collect.

End-User License Agreement for Telex® Software

IMPORTANT - Please read this document carefully before using this product.

THIS DOCUMENT STATES THE TERMS AND CONDITIONS UPON WHICH TELEX COMMUNICATIONS, INC. (the "COMPANY") OFFERS TO LICENSE THE INSTALLED SOFTWARE OR PROGRAM ("the SOFTWARE") FOR USE WITH THE PRODUCT IN WHICH IT WAS INSTALLED. YOU ARE AGREEING TO BECOME BOUND BY THE TERMS OF THIS AGREEMENT. IF YOU DO NOT AGREE TO THE TERMS OF THIS AGREEMENT, DO NOT USE THIS PRODUCT. PROMPTLY RETURN THE PRODUCT TO THE PLACE WHERE YOU OBTAINED IT FOR A FULL REFUND.

The installed software as supplied by the Company is licensed, not sold, to you for use only under the terms of this license, and the Company reserves all rights not expressly granted to you. You own the product or other media on or in which the Software is originally or subsequently recorded or fixed, but the Company retains ownership of all copies of the Software itself.

1. License: This license allows you to use the Software for internal purposes only on a single product in which it was installed.

2. Restrictions: (a) You may not market, distribute or transfer copies of the Software to others or electronically transfer or duplicate the Software. YOU MAY NOT REVERSE ENGINEER, DECOMPILE, DISASSEMBLE, MODIFY, ADAPT, TRANSLATE, RENT, LEASE OR LOAN THE SOFTWARE OR CREATE DERIVATIVE WORKS BASED ON THE SOFTWARE OR ANY ACCOMPANYING WRITTEN MATERIALS. (b) The Software and the accompanying written materials are copyrighted. Unauthorized copying of the Software, including portions thereof or the written materials, is expressly forbidden. (c) You understand that the Company may update or revise the Software and in so doing incurs no obligation to furnish such updates to you.

3. Limited Warranty: The Company does not warrant that the operation of the Software will meet your requirements or operate free from error. The Company DISCLAIMS ALL OTHER WARRANTIES AND CONDITIONS EITHER EXPRESS OR IMPLIED, INCLUDING THE WARRANTIES OF MERCHANTABILITY, FITNESS FOR A PARTICULAR PURPOSE AND NON-INFRINGEMENT OF THIRD PARTY RIGHTS.

4. Limited Liability: The liability of the Company for any claims arising out of this License based upon the Software, regardless of the form of action, shall not exceed the greater of the license fee for the Software or \$50.

This page intentionally left blank.

TABLE OF CONTENTS

DESCRIPTION AND SPECIFICATIONS	7
GENERAL DESCRIPTION	7
FEATURES.	7
FRONT PANEL DESCRIPTION	7
BACK PANEL / CIRCUIT BOARD SWITCHES AND CONNECTORS	8
SPECIFICATIONS	9
INSTALLATION	10
UNPACKING AND INSPECTION.	10
WKP-4 BOX INSTALLATION	10
TKP-4 BOX INSTALLATION	10
CONFIGURATION SWITCHES	10
DIP Switches	10
Address Switch	11
CONNECTIONS	12
Mic Connector.	12
Headset Connector	12
Connection To Intercom System	12
Power Connection.	13
STARTUP AND OPERATIONAL CHECK	13
KEYPANEL SETUP.	14
ASSIGNING INTERCOM KEYS	14
CLEARING KEY ASSIGNMENTS	14
PRINTING DESIGNATION STRIPS	15
CHANGING SETUP PAGES.	15
OPERATION	15
HEADSET BUTTON OPERATION	15
DIP switch 4 in Open position (default)	15
DIP switch 4 in Closed position.	15
INTERCOM KEY OPERATION	15
Momentary vs Latching Operation	15
Intercom Key Operation for Different Types of Key Assignments.	16
Intercom Key Indications	16
CALL WAITING OPERATION FOR INCOMING CALLS.	16
OPERATION WITH THE TIF-951 TELEPHONE INTERFACE	17
DISPLAYING KEY ASSIGNMENTS	17
DISPLAYING THE PORT NUMBER	17

LIST OF FIGURES

Figure 1. Front Panel View.	7
Figure 2. BKP-4 Back Panel View.	8
Figure 3. WKP-4/TKP-4 Configuration Switches and Connectors on Circuit Board (WKP-4 Shown)	8
Figure 4. WKP-4 Mounting Box Dimensions	9
Figure 5. RJ12 Intercom cable wiring diagram	12
Figure 6. 9-pin Intercom cable wiring diagram.	13
Figure 7. Intercom and Power Terminal Block Pinouts for the TKP-4 / WKP-4.	13
Figure 8. Use tie wraps to secure the cables (WKP-4 installation).	13
Figure 9. Call Waiting Window and Key	13
Figure 10. Scroll, Copy and Clear Buttons	14

LIST OF TABLES

Table 1. Address number vs intercom port numbers for 8-Port Audio I/O Cards (ADAM and ADAM CS Intercom Systems)	18
Table 2. Address number vs intercom port numbers for 12-Port Audio I/O Cards (ADAM Intercom Systems)	19

1 DESCRIPTION AND SPECIFICATIONS

1.1 GENERAL DESCRIPTION

The BKP-4, TKP-4, and WKP-4 are ideal for users who want full access to the most commonly used keypad features, and who generally communicate with four or less locations in the intercom system at any given time. The BKP-4 is suitable for desktop use and is powered from an AC mains outlet. The TKP-4 is designed to fit in a Tektronics equipment bay. The WKP-4 is designed for wall mounting. The TKP-4 and WKP-4 may be ordered with a universal AC power supply, or the installer can supply power from another source.

1.2 FEATURES

- Works with ADAM™, ADAM CS and Zeus™ Digital Matrix Intercom Systems.
- Full-function intercom keys with LED indicators.
- Alphanumeric call waiting display with response key. (Call waiting display is optional on the WKP-4.)
- Access to intercom key and setup page assignments. (Optional on WKP-4.)
- 4-wire, balanced audio input and output.
- Several microphone/speaker/headphone combinations possible, including: Headset (microphone + headphones), headphones + panel mounted microphone, speaker + panel mounted microphone, speaker + handheld microphone. Works with: RTS headsets with A4M connector, and MCP5 and MCP6 Panel Microphones.
- Easy installation setup.
- Ready for worldwide use. The BKP-4 accepts any mains voltage from 90-240 VAC, 47/63 Hz. The TKP-4 and WKP-4 can be powered from an optional AC adapter which accepts 100-240 VAC, 47/63. Alternatively, the TKP-4 and WKP-4 may be powered from a user-supplied, 15-24 VDC, 1 amp, regulated power source.)

1.3 FRONT PANEL DESCRIPTION

- 1) Intercom Keys: Assignable for several types of operation, including talk only, listen only, talk with auto-listen, and all-call (where activating the key also activates all keys to the left of that key). Keys feature momentary or latching operation. For momentary operation, the operator presses and holds a key while communicating, then releases it when finished. For latching operation, the operator taps a key to turn it on, then taps it again to turn it off.

Latching can be disabled via an options switch (13) or from ADAMedit or ZEUSedit.

- 2) Key Indicators: Two bi-color (red and green) LED indicators for each key. Provide indications for talk on/off, listen on/off, incoming call, busy (for keys assigned to talk to IFB's), and in-use (for keys assigned to talk to either IFB's or ISO's).
- 3) Designation Strip Holder: Holds printed strip identifying key assignments. Works with ADAMedit and ZEUSedit designation strip print feature.
- 4) Call Waiting Display (Optional on WKP-4) and Response Key: 4-character, alphanumeric display for incoming caller names. Talkback to caller via the response key. The call waiting window and response key are also used with the copy, clear, and scroll keys (5).
- 5) Copy, Clear, and Scroll keys (Optional on the WKP-4): Used for key and setup page assignment. Can also be used to talk to any location in the intercom system when no intercom key is assigned. (Note: There are 4 setup pages. Each contains a complete set of key assignments.)
- 6) Headset On/Off Key with Indicator. When the headset is on, the speaker output and panel mic are off.
- 7) Listen Volume Control for Headset or Speaker.
- 8) Panel Mic Connector: 1/4", 3-conductor phone jack. Accepts MCP5 or MCP6 Panel Microphone.
- 9) Monaural Headset Connector: A4F (XLR-4F) connector. Accepts any RTS headset with A4M (XLR4M) connector. Also accepts monaural headphones for use with a panel microphone, or accepts a handheld microphone for use with the speaker.

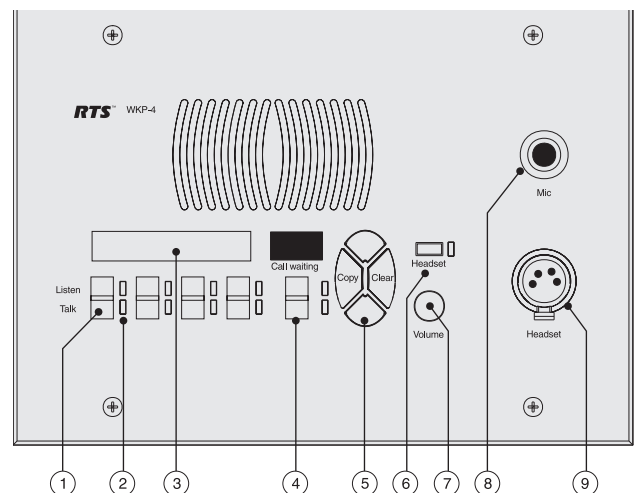

Figure 1. Front Panel View. (Numbered items refer to front panel description.)

1.4 BACK PANEL / CIRCUIT BOARD SWITCHES AND CONNECTORS

- 10) BKP-4: Universal Power Input: Accepts any mains voltage from 90-240 VAC, 47-63 Hz.
TKP-4 and WKP-4: Terminals for DC power connection.
- 11) Intercom Frame Connectors. All units have both 9-pin female Dsub (DE9S) and RJ12 connectors. The TKP-4 and WKP-4 also include spring-clamp terminals.
- 12) Options DIP Switches:
- Name Display for Assigned Keys: Assigned intercom keys provide an LED flash for incoming call announce. Optionally, the caller's name can also be displayed in the call waiting window. (Incoming calls from unassigned callers are always displayed in the call waiting window.)
 - Incoming Call Timeout Select: Incoming call LED flash can be set for 15 seconds, or until the caller's key is released.
 - Speaker / Microphone Selection: A DIP switch, together with the front panel Headset switch, permits any of the following speaker / microphone combinations: internal speaker with panel microphone; headphones with panel microphone; speaker with 4-pin dynamic microphone; headset with boom-mounted dynamic mic.
 - Latching: The electronic latching feature for the intercom keys can be turned on or off as previously mentioned.
- 13) Address Select Switch: 16-position rotary switch: Selects the keypanel's location in an intercom group. The combination of intercom group number and Address switch setting determines a keypanel's unique address within the intercom system. Note: Only positions 1-8 are used for Zeus and ADAM CS intercom systems, or ADAM intercom systems with 8-port Audio I/O cards. Only positions 1-C are used for ADAM intercom systems with 12-port Audio I/O cards. The remaining switch positions are not used.

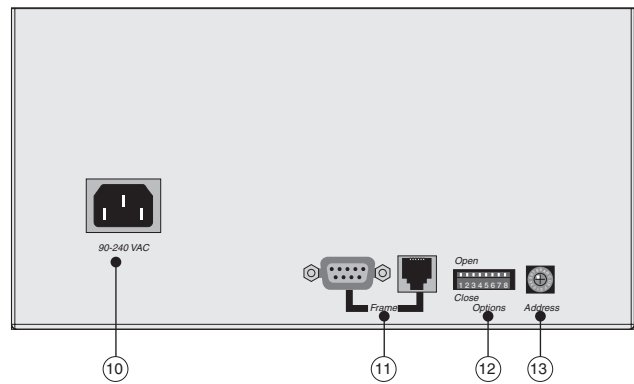

Figure 2. BKP-4 Back Panel View.

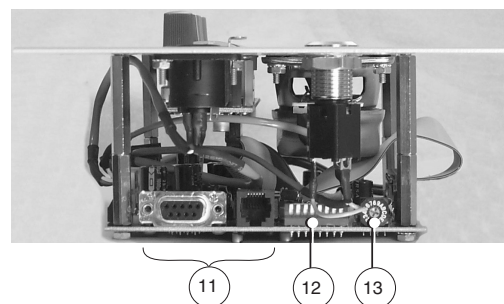
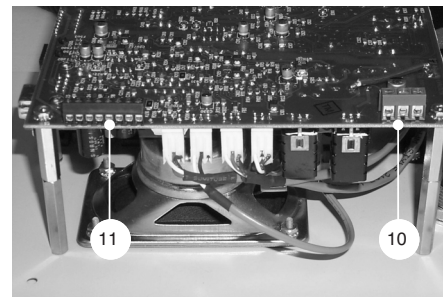

Figure 3. WKP-4/TKP-4 Configuration Switches and Connectors on Circuit Board (WKP-4 Shown)

1.5 SPECIFICATIONS

Matrix Input/ Output

8 dBu nominal, 20 dBu maximum

Audio Performance

SNR at 8 dBu (A-weighted): > 70 dB

THD+N at 8 dBu (Unweighted): < 0.5%

Frequency Response at 8 dBu: ± 1.5 dB from 100 Hz - 20 kHz

CMRR: > 70 dB

Panel Mic Input

Mic Type: Electret condenser

Power: Phantom (+5V DC)

Nominal Level: -42 dBu

Maximum Level: -25 dBu

Connector Type: 1/4", 3-conductor phone jack.

Tip: +Audio and DC bias

Ring: -Audio

Sleeve: No connection

Headset

Mic

Type: Dynamic

Nominal Level: -55 dBu

Maximum Level: -40 dBu

Headphone

Impedance: 50 to 600 ohms

Output Power: 150 mW into 50 ohms

Output Voltage Level: 8 volts p-p maximum

Connector Type: D4F (Mates with A4M)

Pin 1: Microphone -

Pin 2: Microphone +

Pin 3: Headphone -

Pin 4: Headphone +

Speaker

Output: 4 Watts into 8 ohms maximum

Environmental

Operating Temperature: -20°C to 50°C

Storage Temperature: -40°C to 85°C

Humidity: 0 to 95%, non-condensing

Power Requirements

WKP-4: 15-24 VDC, 1 amp, regulated

BKP-4: 90 to 240 VAC, 47 / 63 Hz

Dimensions

WKP-4 (without mounting box): 6.5" (165mm) high x 9" (229mm) wide x 2.8" (71mm) deep behind front panel. WKP-4 Mounting Box: See Figure 4.

TKP-4: 5.2" (132mm) high x 8.38" (213mm) wide x 3.25" (83mm) deep behind front panel.

BKP-4: 4.6" (117mm) high x 9" (229mm) wide x 7" (178mm) deep

Finish

Aluminum front panel and case, light gray finish

Approvals

UL, CSA, VDE, CE

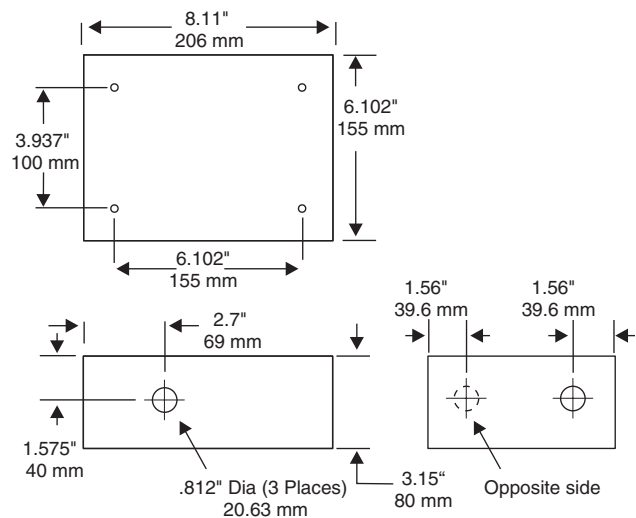

Figure 4. WKP-4 Mounting Box Dimensions

2 INSTALLATION

2.1 UNPACKING AND INSPECTION

As soon as possible after receipt, inspect the container and contents for physical damage that may have occurred in shipping. If damage has occurred, immediately (within 24 hours of receipt of equipment) contact the carrier involved and file a claim. Save all packing materials, and request an immediate inspection by the carrier's insurance claims agent. The container includes one or more of the following items, depending on the order:

Quantity	Description
1	BKP-4, TKP-4, or WKP-4 Keypanel
1	Power Cord (BKP-4 only)
1	User Manual
1	WKP-4 Mounting Box (Optional)
1	AC Power Adapter. Input: 100-240 VAC, 47-63 Hz, .4A. Output: 15 VDC, 1A max (Optional, used only for WKP-4 and TKP-4)

2.2 WKP-4 BOX INSTALLATION

1. If the WKP-4 was supplied assembled to the mounting box, remove the four (4) screws from the front panel.

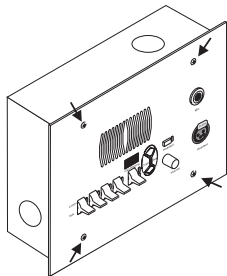

2. Mount the box in a suitable size wall opening using appropriate mounting screws (not supplied).

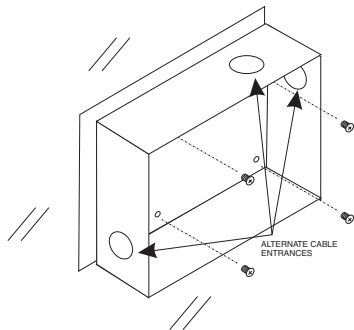

3. Route the intercom and power wires into the box. Reinstall the front panel after all dip switch settings and connections are completed as described on the following pages.

☞ If you are not using conduit to route the cables, use a plastic bushing or similar device at the cable entrance into the box to prevent abrasion of the wires.

2.3 TKP-4 BOX INSTALLATION

Insert the TKP-4 into a Tektronics equipment bay so that the spring clips are fully seated.

2.4 CONFIGURATION SWITCHES

☞ **Important!** If you change any configuration switch settings during operation, you must momentarily turn off power to reset.

2.4.1 DIP Switches

DIP Switch 1

Open: Default setting. All incoming calls appear in the call waiting display (if present).

Closed: Only calls for unassigned callers appear in the call waiting display (if present).

Description: Any intercom key that is already assigned to talk/listen to a specific intercom port will always provide an LED flash for incoming calls from that port. If a designation strip is used (see Printing Designation Strips, page 15) the keypanel operator can identify the caller from the designation strip. Optionally, the caller's name can also display in the call waiting window. If you don't want this to happen, set DIP switch 1 to Close.

☞ The above description applies only to assigned keys. Whenever there is an incoming call, and there is no key assigned to the caller, that caller's name will always display in the call waiting window.

DIP Switch 2

Open: Default setting. 15 second flash after incoming call is received.

Closed: LED flash until caller releases key.

Description: Whenever there is an incoming call and there is a talk key assigned to the caller, the talk LED next to that key will flash. The flash can be set for 15 second timeout, or until the caller's talk key is released.

DIP Switch 3

Open: Default setting. TIF-951 operation enabled.

Closed: keypanel cannot answer incoming calls to TIF-951.

Description: The keypanel can answer incoming telephone calls received by an RTS Model TIF-951 Telephone Interface. However, it cannot perform any other telephone operations. For example, it cannot force the TIF-951 to hang up at the end of a call. In many cases, the TIF-951 can detect a hang up at the far end of the line and then hang up itself. However, this may not always be the case in all phone systems. In such cases you may wish to completely disable keypanel operation with the TIF-951.

DIP Switch 4

Open: Default setting. Use a panel mic (connected to the Mic connector) to talk and use the speaker to listen. Or, use a headset (connected to Headset connector) to talk and listen.

Closed: Special Applications. Use a dynamic mic (connected to the Headset connector) with the speaker. Or, use headphones (connected to the Headset connector) with a panel mic (connected to the Mic connector).

Description: Typically, you will use the keypanel either with a panel microphone and a speaker or with a headset. The special applications setting is seldom used.

DIP Switch 5

Open: Default setting. Latching turned on.

Closed: Latching turned off.

Description: An intercom key can always be turned on for momentary conversation by pressing and holding the key during the conversation. There is also an electronic latching feature that lets you tap intercom keys to turn them on or off. This permits convenient hands-free conversation. However it can also result in a talk circuit being left on unintentionally. For example, a key that talks to a public address system could be accidentally left on. Or an IFB key (a type of key assignment that is often used by a director or producer to give instructions to a listener, such as a news anchor during a television broadcast) could accidentally be left on, causing confusion for the IFB listener. To prevent such accidents, the latching feature can be turned off.

DIP Switches 6-8

Not used. Leave Open.

2.4.2 Address Switch

☞ In Zeus, ADAM CS, and ADAM intercom systems, intercom ports are arranged in groups of 8 or 12 intercom ports. Within each group, each keypanel is uniquely identified by its Address switch setting.

The Address switch has a white pointer which points to the current switch setting. Determine the proper setting as follows:

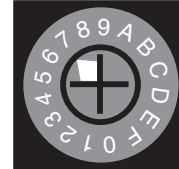

Important! Always reset the keypanel after changing the Address switch setting. Do this by briefly removing power to the keypanel.

Zeus Intercom Systems: Intercom port connectors on the Zeus back panel are arranged in three groups of eight intercom ports. For each group, intercom port connectors are labeled ID 1, ID 2, etc. When you connect a keypanel to Zeus, set the keypanel Address switch to match the corresponding ID number on the Zeus back panel. Note that address switch settings 0, and 9 through F are not used.

ADAM CS Intercom Systems: Each Audio I/O card contains 1 group of 8 intercom ports. However, the method of breaking out the groups depends on the type of connectors on the back panel. To determine the keypanel Address switch setting, use the planning worksheets in the ADAM CS Installation Manual. These are located near the back of the Installation Manual:

- **ADAM CS with RJ12 or DB-9 back panel:** You can determine the keypanel address from the worksheets in either of two ways: 1) If you know the port number that a keypanel will be connected to, look up the port number in the worksheet, then read across to the appropriate logical keypanel number for that port number. Use that number to set the keypanel Address switch. 2) If you know the connector number (on the back of the ADAM CS frame) that the keypanel will be connected to, look up that connector number in the worksheet, then read across to the appropriate logical keypanel number. Use that number to set the keypanel Address switch. Note that address switch settings 0, and 9 through F are not used.

- ADAM CS frame with 50-pin Telco back panel:**
 You can determine the keypanel address from the worksheet in either of two ways: 1) If you know the port number that a keypanel will be connected to, look up the port number in the worksheet, then read across to the appropriate logical keypanel number for that port number. Use that number to set the keypanel Address switch. 2) If you know the connector numbers and pin numbers that the keypanel will be connected to, look up these numbers in the worksheet, then read across to the appropriate logical keypanel number. Use that number to set the keypanel Address switch. Note that address switch settings 0, and 9 through F are not used.

ADAM Intercom Systems: Each Audio I/O contains 1 group of either 8 or 12 intercom ports per card. However, the individual intercom ports may be broken out using various types of breakout panels or punch blocks, and groups may not be easily identified. It may be easier to set the keypanel Address switch using the actual intercom port numbers. To do this, refer to Table 1, page 18 (for 8-port cards) or Table 2, page 19 (for 12-port cards). Locate the intercom port number to which the keypanel will be connected. Then, read across to the "Address" column to find the Address number. Set the keypanel Address switch to this number. Note: settings 0, and 9 through F are not used with 8-port cards settings 0, and C through F are not used with 12-port cards.

2.5 CONNECTIONS

2.5.1 Mic Connector

To connect a panel microphone, such as the RTS model MCP5 or MCP6, screw the microphone into the Mic connector on the front panel of the keypanel.

For Mic connector specifications, see page 9.

2.5.2 Headset Connector

The Headset connector accepts a monaural, dynamic-microphone headset (headphones and microphone). If you use a headset, make sure DIP switch 4 is set to the Open position (page 11).

Alternatively, headphones can be connected when a panel microphone is used for talkback. Or, a handheld dynamic microphone can be connected when a speaker is used for listening. If you use either of these special configurations, make sure DIP switch 4 is set to the Close position (page 11).

For Headset connector specifications, see page 9.

2.5.3 Connection To Intercom System

BKP-4 Connection

Use a standard RTS intercom cable. Either a 9-pin or RJ12 type can be used. Refer to Figure 5 or 6. Plug one end of the cable into the appropriate Frame connector on the back panel of the keypanel. Plug the other end into the appropriate port of the intercom system. (This will be the port number that you designated previously when setting the Address switch.)

Keypanels may be connected while the intercom system is running.

Note that 9-pin intercom cables for use with an ADAM CS frame must use special connectors at the intercom matrix end as described in Figure 6.

TKP-4 / WKP-4 Connection

You can use either type of standard intercom cable as shown in Figure 5 or 6. Alternatively, you can connect directly to the terminal block as shown in Figure 7. In either case, use tie wraps to secure the wires as shown in Figure 8.

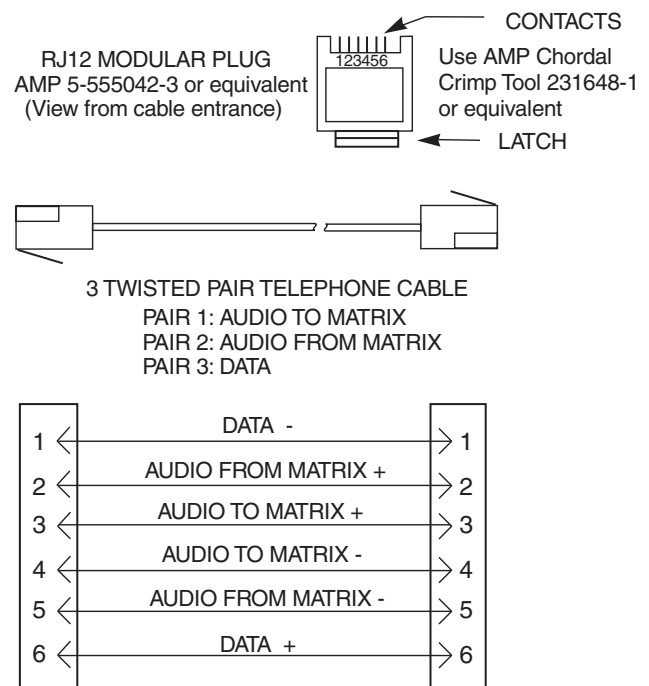
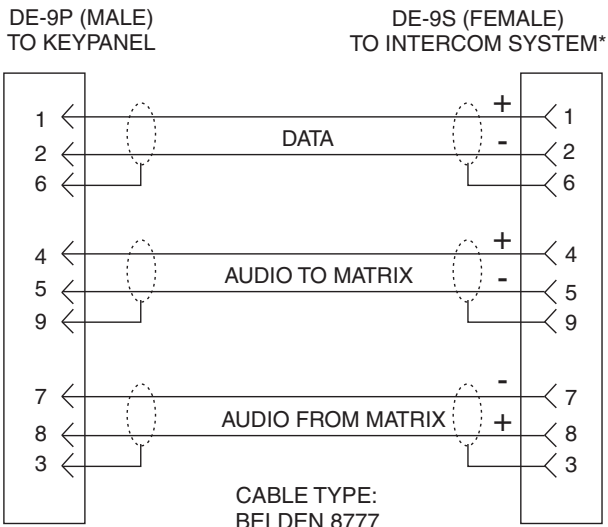

Figure 5. RJ12 Intercom cable wiring diagram



IMPORTANT!

* When connecting to an ADAM CS back panel, use only low-profile cable connectors such as AMP Part No. 747516-3 (Telex Part No. 59926-678)

Figure 6. 9-pin Intercom cable wiring diagram. Important: Shield connections at keypanel end are optional and may cause ground loops if used.

2.5.4 Power Connection

BKP-4: Plug an power cord (not supplied) into the power connector and into any 90-240 VAC, 47-63 Hz main power source.

TKP-4 / WKP-4: Connect an optional AC adapter using the color-code information on the AC adapter and the terminal pinout information in Figure 7. Alternatively, connect any well regulated and filtered 15 VDC, 1 amp power source to the power terminals.

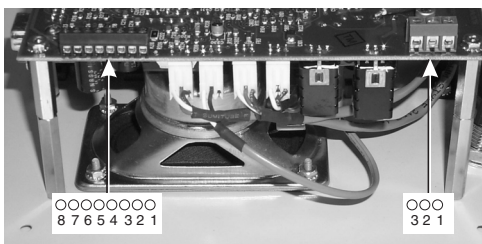

<p>INTERCOM</p> <p>PIN 1: DATA PLUS (+) PIN 2: DATA MINUS (-) PIN 3: NO CONNECTION PIN 4: AUDIO TO MATRIX PLUS (+) PIN 5: AUDIO TO MATRIX MINUS (-) PIN 6: NO CONNECTION PIN 7: AUDIO FROM MATRIX MINUS (-) PIN 8: AUDIO FROM MATRIX PLUS (+)</p>	<p>POWER</p> <p>PIN 1: PLUS (+) 15 VDC PIN 2: NO CONNECTION PIN 3: COMMON (GND)</p>
---	--

Figure 7. Intercom and Power Terminal Block Pinouts for the TKP-4 / WKP-4.

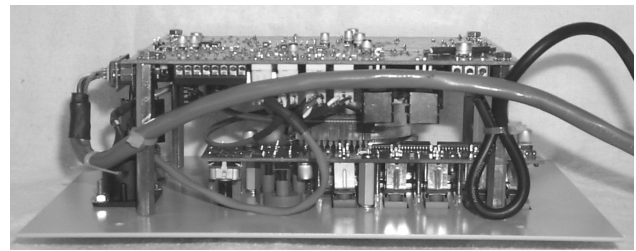

Figure 8. Use tie wraps to secure the cables (WKP-4 installation).

2.6 STARTUP AND OPERATIONAL CHECK

When power is applied, all LEDs will first flash red, then green. This confirms that all LEDs are working correctly. Also, the call waiting window will display asterisks (****) then dashes (----).



Figure 9. Call Waiting Window and Key

☞ If the keypanel cannot establish data communications with the intercom system, asterisks will continue to display. Check the intercom cable connections (in particular, the data connections).

Several symptoms may occur if the keypanel address is incorrectly set: 1) there may be no indication when there is an incoming call; 2) when an intercom key is pressed to talk, the destination may not hear the audio, 3) the call waiting display may behave erratically. If any of these symptoms occur, recheck the keypanel Address switch setting.

☞ **Important!** Always reset the keypanel after changing the Address switch setting. Do this by briefly removing power to the keypanel.

If installing a WKP-4, assemble the front panel into the mounting box using the screws supplied with the WKP-4.

This completes the standard installation procedures.

3 KEYPANEL SETUP

3.1 ASSIGNING INTERCOM KEYS

You can assign keypanel intercom keys using ZEUSedit or ADAMedit. For help with key assignment in ZEUSedit or ADAMedit, click the KP button on the program's toolbar, then press the F1 key on the computer keyboard for help.

If your keypanel has Copy, Clear, and Scroll buttons, you can also assign keys at the keypanel, with the following exceptions: 1) Special functions (auto follow, auto listen, etc.) cannot be assigned. 2) You can only assign one destination to each talk key (talk level 1). If you need to assign special functions, or activate two destinations with a single talk key (talk level 1 and talk level 2) you must assign the key using ZEUSedit or ADAMedit. Note: If you assign talk level 1 from the keypanel, it will erase any talk level 2 assignment that you previously assigned using ZEUSedit or ADAMedit.

Assign intercom keys at the keypanel as follows:

1. Make sure the key that you want to assign is off.
2. Press the Scroll Up or Scroll Down key to view the list of intercom names in the call waiting window.

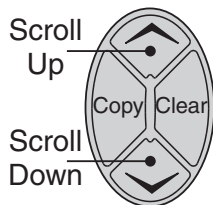

Figure 10. Scroll, Copy and Clear Buttons

If you start by pressing Scroll Up, the list will start with all point-to-point names. On power up the keypanel only displays the point-to-point names. Examine or assign a name from a different scroll list as follows:

- 1) Make sure that the CWW (call waiting window) is clear. (Dashes should display.)
- 2) Hold the call waiting window key down and tap the Scroll Up button. The CWW displays PL for party lines. Click on the Scroll Up or Scroll Down button to go through the different scroll lists available.
- 3) To select a particular scroll list, tap the Copy button.

- 4) You can go through the names in the selected scroll lists by tapping the Scroll Up or Scroll Down button.
- 5) Tap the CWW key up to return to normal operation.

☞ You can scroll one name at a time by clicking and immediately releasing the Scroll Up or Scroll Down button. If you press and hold the button it will start scrolling slowly through the names. After a few seconds the scroll speed will increase. This is useful when you need to scroll through a long list.

☞ The following types of names may not appear in the scroll list: UPL Resources, IFB's, Relays (GPI outputs), and ISO's. This is because the scroll enable check boxes for these items may not be checked in ADAMedit or ZEUSedit. If you don't know how to activate these check boxes, proceed as follows: Run ADAMedit (or ZEUSedit). Then, press the F1 key on your computer for help. Click the Search button in help, and type "UPL Resources" or "IFB", etc (without the quote marks). From the list of available help topics, select any topic that tells you how to access or set up the item that you typed. For example, there is a topic that tells you how to access UPL Resources. Once you access UPL Resources, again press the F1 key for help. Within the new help screen, you should find help with the scroll enable feature.

3. When the name you want to assign is displayed in the call waiting window, release the Scroll button.
4. Press and hold the Copy button, then tap down on an intercom key to assign talk, or tap up to assign listen. The talk or listen LED will blink once to confirm the assignment.

☞ To assign both talk and listen, continue holding the Copy button while tapping the intercom key both up and down.

5. Press the Clear button to return to normal operation after assigning keys. Otherwise, if you do nothing, the keypanel will automatically return to normal operation after about 30 seconds.

3.2 CLEARING KEY ASSIGNMENTS

1. Make sure that the key or keys that you want to clear are turned off.
2. Press up and release the call waiting key. This clears the call waiting display. (Dashes should display.)

3. Press and hold the Copy button, then tap the intercom key that you want to clear. Tap up to clear the listen assignment. Tap down to clear the talk assignment. The talk or listen LED will flash to confirm that the key assignment is cleared. You can tap several keys in succession to clear them while continuing to hold down the Copy button.

3.3 PRINTING DESIGNATION STRIPS

Currently in development.

3.4 CHANGING SETUP PAGES

There are 4 setup pages available. Each setup page can contain a complete set of key assignments. By changing the setup page you can therefore quickly change all of the keys assignments. Change the setup page as follows:

1. Make sure all intercom keys are off.
2. Press and hold the Clear button.
3. While holding the Clear button, press and hold the Copy button. The currently assigned setup page will display in the call waiting window. PG 1 means Page 1; PG 2 means Page 2 and so forth.
4. Release both buttons.
5. Tap the Scroll Up or Scroll Down button to select the desired setup page.
6. Tap the Copy button to assign the selected setup page. The topmost LED next to the call waiting key will flash briefly to confirm the assignment.

4 OPERATION

4.1 HEADSET BUTTON OPERATION

Operation of the Headset button depends on the position of DIP switch 4 on the back panel (page [11](#)):

4.1.1 DIP switch 4 in Open position (default)

- Startup Settings: The panel mic connector (Mic) and the speaker will both be on. The Headset connector will be off. The Headset button and LED will be off.
- Headset Button Off: Talk with a panel microphone and listen with the speaker.
- Headset Button On: Talk and listen with a headset.

4.1.2 DIP switch 4 in Closed position

- Startup Settings: The Speaker will be on at startup. The microphone input of the Headset connector will be on. The Headset button and LED will be off.
- Headset Button Off: Listen with the speaker and talk using a dynamic microphone connected to the Headset connector.
- Headset Button On: Listen with headphones connected to the Headset connector and talk with a panel microphone connected to the Mic connector.

4.2 INTERCOM KEY OPERATION

4.2.1 Momentary vs Latching Operation

For momentary key activation, press and hold an intercom key. For latching operation, tap the key to turn it on, and tap it again to turn it off.

 If the LED next to a key does not turn on when the key is activated, this means the key is not currently assigned.

 The electronic latching feature (DIP switch 5) must be enabled in order to use latching. See page [11](#) for details.

4.2.2 Intercom Key Operation for Different Types of Key Assignments

Basic Talk and/or Listen Key Operation: The down position activates talk (if assigned). The up position activates listen (if assigned). Talk and listen may be latched on or off independently by tapping up or down.

☞ The following paragraphs describe special types of key assignments called special functions. These types of key assignments can only be set up using the ADAMedit or ZEUSedit software, and they are described in detail in the software help file. To find out if a key has a special function assignment, you can display the key's assignment as described under "Displaying Key Assignments" on page 17. If a special function is assigned to a listen key, you will see AF, or AL, etc. when you display the key assignment.

Talk+Auto-follow (AF) Listen Key Assignment: This key assignment works the same as the basic talk/listen key assignment: The down position activates talk, and the up position activates listen. Talk and listen may be turned on or off independently by pressing up or down.

Talk+Auto-listen (AL) Listen Key Assignment: The down position activates both talk and listen. However, only the talk LED will turn on. If talk is on, you cannot turn off listen. If talk is off, you can turn listen on independently by pressing up.

Talk+Auto-mute (AM) Listen Key Assignment: The down position activates talk. And, if listen is on, it automatically turns off until talk is released. When talk is off, listen may be turned on independently by pressing up.

Talk+Auto-reciprocal (AR) Listen Key Assignment: The down position activates talk. Listen is always on and continuously monitors whatever is assigned to the talk position.

All Call (AC) Talk Key Assignment: When a talk key is assigned as an All Call key, it operates only as a switch to turn on or off all talk keys to the left of the All Call key. These other talk keys will then activate according to the way they have been assigned. Note that this will also affect any listen keys that have been assigned with special functions. For example, an auto listen key will also activate if its corresponding talk key has been activated by an All Call key.

4.2.3 Intercom Key Indications

Talk Indicator:

- Solid green: Talk is activated.
- Green flashing "incoming call" indication: The person assigned to the key is calling. Activate the key to talk back.
- Continuous red "in use" indication: An "in-use" indication is provided for an IFB or ISO key. It is also provided for a key that talks to a remote intercom system (when your intercom system is equipped with optional trunking). The "in-use" indication warns you that someone else is currently talking.
- Red flashing "busy" indication: May occur when a key is activated to talk to an IFB or a remote intercom system. This indicates that some other keypanel with a higher priority is currently talking and you cannot talk at this time.

Listen Indicator:

- Solid green: Listen is activated. (This indication will only be provided when you manually turn listen on by tapping or pressing upward on a key. It will not occur if listen has been automatically activated during talk.)

4.3 CALL WAITING OPERATION FOR INCOMING CALLS

As previously described, the talk indicator for a key will flash when there is an incoming call to that key, and you may activate that key to talk back. Also, if DIP switch 1 (page 10) was set to the Open position, the caller's name will appear in the call waiting window, and you may press down on the call waiting key instead to talk back. If a caller is not already assigned to an intercom key, the caller's name will always appear in the call waiting window, and you must use only the call waiting key to talk back.

If a second call is received in the call waiting window while a caller's name is already displayed there, the call waiting display will start to flash. Also, the topmost LED next to the call waiting key will turn on. When there are multiple calls, use the call waiting key as follows:

1. To talk to the currently displayed caller, press down on the call waiting key.
2. To clear the currently displayed caller name, briefly tap up on the call waiting key. The next caller's name will then appear in the call waiting window, and you may press down on the call waiting key to talk back.

3. Continue talking to callers and clearing their names until the call waiting window displays dashes (no callers). Also, when all calls have been answered, the green LED next to the call waiting key will turn off.

4.4 OPERATION WITH THE TIF-951 TELEPHONE INTERFACE

If DIP switch 3 (page 10) is set to the Open position, you can use the keypanel to answer incoming telephone calls that have been received by the TIF-951. A talk and listen key pair on the keypanel must be assigned to talk/listen to the TIF-951 as previously described. Use the assigned keys as follows:

1. Leave the talk and listen keys in the off position, except when answering a call.
2. When there is an incoming phone call, the talk indicator will flash red. Activate the talk key to talk back. You may also have to activate the listen key.
3. When the conversation is finished, turn the keys off.

 **Important!** The keypanel does not hang up the phone line when you turn the keys off. Usually the TIF-951 does this by detecting when the caller has hung up. However, this may not be possible in some phone systems, and the TIF-951 may remain off hook. In this case you must manually disconnect using the OFF switch on the front of the TIF-951.

 Unless there is an incoming call to answer, activating a key on the MKP-4 that is assigned to the TIF-951 will have no effect.

4.5 DISPLAYING KEY ASSIGNMENTS

 You can use this feature to check key assignments after making changes. You can also use it if you think the key assignments have been changed but the designation strip has not been updated.

1. Press up and release the call waiting key to clear the call waiting window. (Dashes should display when the window is clear.)
2. Press down and hold the call waiting key. Then tap an intercom key down or up to display the talk or listen assignment. You may press several keys in succession to check their assignments.
3. Release the call waiting key when finished.

4.6 DISPLAYING THE PORT NUMBER

Occasionally, you may need to know which intercom port your keypanel is connected to. Identify the port number as follows:

1. Make sure the Call Waiting window is clear. (Dashes should display. If not, press upward on the Call Waiting key.)
2. Hold down the Call Waiting key.
3. While holding down the Call Waiting key, tap the Clear key. The port number will appear in the Call Waiting display. This is the port that the keypanel is connected to. N001 indicates port 1, N002 indicates port 2 and so forth.

Table 1. Address number vs intercom port numbers for 8-Port Audio I/O Cards (ADAM and ADAM CS Intercom Systems)

Address	Card Numbers (bold headings) and Port Numbers																								
Cards 1-25																									
	1	2	3	4	5	6	7	8	9	10	11	12	13	14	15	16	17	18	19	20	21	22	23	24	25
1	1	9	17	25	33	41	49	57	65	73	81	89	97	105	113	121	129	137	145	153	161	169	177	185	193
2	2	10	18	26	34	42	50	58	66	74	82	90	98	106	114	122	130	138	146	154	162	170	178	186	194
3	3	11	19	27	35	43	51	59	67	75	83	91	99	107	115	123	131	139	147	155	163	171	179	187	195
4	4	12	20	28	36	44	52	60	68	76	84	92	100	108	116	124	132	140	148	156	164	172	180	188	196
5	5	13	21	29	37	45	53	61	69	77	85	93	101	109	117	125	133	141	149	157	165	173	181	189	197
6	6	14	22	30	38	46	54	62	70	78	86	94	102	110	118	126	134	142	150	158	166	174	182	190	198
7	7	15	23	31	39	47	55	63	71	79	87	95	103	111	119	127	135	143	151	159	167	175	183	191	199
8	8	16	24	32	40	48	56	64	72	80	88	96	104	112	120	128	136	144	152	160	168	176	184	192	200
Cards 26-50																									
	26	27	28	29	30	31	32	33	34	35	36	37	38	39	40	41	42	43	44	45	46	47	48	49	50
1	201	209	217	225	233	241	249	257	265	273	281	289	297	305	313	321	329	337	345	353	361	369	377	385	393
2	202	210	218	226	234	242	250	258	266	274	282	290	298	306	314	322	330	338	346	354	362	370	378	386	394
3	203	211	219	227	235	243	251	259	267	275	283	291	299	307	315	323	331	339	347	355	363	371	379	387	395
4	204	212	220	228	236	244	252	260	268	276	284	292	300	308	316	324	332	340	348	356	364	372	380	388	396
5	205	213	221	229	237	245	253	261	269	277	285	293	301	309	317	325	333	341	349	357	365	373	381	389	397
6	206	214	222	230	238	246	254	262	270	278	286	294	302	310	318	326	334	342	350	358	366	374	382	390	398
7	207	215	223	231	239	247	255	263	271	279	287	295	303	311	319	327	335	343	351	359	367	375	383	391	399
8	208	216	224	232	240	248	256	264	272	280	288	296	304	312	320	328	336	344	352	360	368	376	384	392	400
Cards 51-75																									
	51	52	53	54	55	56	57	58	59	60	61	62	63	64	65	66	67	68	69	70	71	72	73	74	75
1	401	409	417	425	433	441	449	457	465	473	481	489	497	505	513	521	529	537	545	553	561	569	577	585	593
2	402	410	418	426	434	442	450	458	466	474	482	490	498	506	514	522	530	538	546	554	562	570	578	586	594
3	403	411	419	427	435	443	451	459	467	475	483	491	499	507	515	523	531	539	547	555	563	571	579	587	595
4	404	412	420	428	436	444	452	460	468	476	484	492	500	508	516	524	532	540	548	556	564	572	580	588	596
5	405	413	421	429	437	445	453	461	469	477	485	493	501	509	517	525	533	541	549	557	565	573	581	589	597
6	406	414	422	430	438	446	454	462	470	478	486	494	502	510	518	526	534	542	550	558	566	574	582	590	598
7	407	415	423	431	439	447	455	463	471	479	487	495	503	511	519	527	535	543	551	559	567	575	583	591	599
8	408	416	424	432	440	448	456	464	472	480	488	496	504	512	520	528	536	544	552	560	568	576	584	592	600
Cards 76-100																									
	76	77	78	79	80	81	82	83	84	85	86	87	88	89	90	91	92	93	94	95	96	97	98	99	100
1	601	609	617	625	633	641	649	657	665	673	681	689	697	705	713	721	729	737	745	753	761	769	777	785	793
2	602	610	618	626	634	642	650	658	666	674	682	690	698	706	714	722	730	738	746	754	762	770	778	786	794
3	603	611	619	627	635	643	651	659	667	675	683	691	699	707	715	723	731	739	747	755	763	771	779	787	795
4	604	612	620	628	636	644	652	660	668	676	684	692	700	708	716	724	732	740	748	756	764	772	780	788	796
5	605	613	621	629	637	645	653	661	669	677	685	693	701	709	717	725	733	741	749	757	765	773	781	789	797
6	606	614	622	630	638	646	654	662	670	678	686	694	702	710	718	726	734	742	750	758	766	774	782	790	798
7	607	615	623	631	639	647	655	663	671	679	687	695	703	711	719	727	735	743	751	759	767	775	783	791	799
8	608	616	624	632	640	648	656	664	672	680	688	696	704	712	720	728	736	744	752	760	768	776	784	792	800

Table 2. Address number vs intercom port numbers for 12-Port Audio I/O Cards (ADAM Intercom Systems)

Address	Card Numbers (bold headings) and Port Numbers																								
	Cards 1-25																								
	1	2	3	4	5	6	7	8	9	10	11	12	13	14	15	16	17	18	19	20	21	22	23	24	25
1	1	13	25	37	49	61	73	85	97	109	121	133	145	157	169	181	193	205	217	229	241	253	265	277	289
2	2	14	26	38	50	62	74	86	98	110	122	134	146	158	170	182	194	206	218	230	242	254	266	278	290
3	3	15	27	39	51	63	75	87	99	111	123	135	147	159	171	183	195	207	219	231	243	255	267	279	291
4	4	16	28	40	52	64	76	88	100	112	124	136	148	160	172	184	196	208	220	232	244	256	268	280	292
5	5	17	29	41	53	65	77	89	101	113	125	137	149	161	173	185	197	209	221	233	245	257	269	281	293
6	6	18	30	42	54	66	78	90	102	114	126	138	150	162	174	186	198	210	222	234	246	258	270	282	294
7	7	19	31	43	55	67	79	91	103	115	127	139	151	163	175	187	199	211	223	235	247	259	271	283	295
8	8	20	32	44	56	68	80	92	104	116	128	140	152	164	176	188	200	212	224	236	248	260	272	284	296
9	9	21	33	45	57	69	81	93	105	117	129	141	153	165	177	189	201	213	225	237	249	261	273	285	297
A	10	22	34	46	58	70	82	94	106	118	130	142	154	166	178	190	202	214	226	238	250	262	274	286	298
B	11	23	35	47	59	71	83	95	107	119	131	143	155	167	179	191	203	215	227	239	251	263	275	287	299
C	12	24	36	48	60	72	84	96	108	120	132	144	156	168	180	192	204	216	228	240	252	264	276	288	300
	Cards 26-50																								
	26	27	28	29	30	31	32	33	34	35	36	37	38	39	40	41	42	43	44	45	46	47	48	49	50
1	301	313	325	337	349	361	373	385	397	409	421	433	445	457	469	481	493	505	517	529	541	553	565	577	589
2	302	314	326	338	350	362	374	386	398	410	422	434	446	458	470	482	494	506	518	530	542	554	566	578	590
3	303	315	327	339	351	363	375	387	399	411	423	435	447	459	471	483	495	507	519	531	543	555	567	579	591
4	304	316	328	340	352	364	376	388	400	412	424	436	448	460	472	484	496	508	520	532	544	556	568	580	592
5	305	317	329	341	353	365	377	389	401	413	425	437	449	461	473	485	497	509	521	533	545	557	569	581	593
6	306	318	330	342	354	366	378	390	402	414	426	438	450	462	474	486	498	510	522	534	546	558	570	582	594
7	307	319	331	343	355	367	379	391	403	415	427	439	451	463	475	487	499	511	523	535	547	559	571	583	595
8	308	320	332	344	356	368	380	392	404	416	428	440	452	464	476	488	500	512	524	536	548	560	572	584	596
9	309	321	333	345	357	369	381	393	405	417	429	441	453	465	477	489	501	513	525	537	549	561	573	585	597
A	310	322	334	346	358	370	382	394	406	418	430	442	454	466	478	490	502	514	526	538	550	562	574	586	598
B	311	323	335	347	359	371	383	395	407	419	431	443	455	467	479	491	503	515	527	539	551	563	575	587	599
C	312	324	336	348	360	372	384	396	408	420	432	444	456	468	480	492	504	516	528	540	552	564	576	588	600

REVISION RECORD

LOC. REV.	DESCRIPTION	ECO NO.	DRFT.	CHKR.	APP.	DATE
	REVC	63639				02/02/99
	RELEASE					

- DL1 590532-000
- DL2 590532-000
- DL3 590532-000
- DL4 590532-000
- DL5 590532-000
- DL6 590532-000
- DL7 590532-000
- DL8 590532-000
- DL9 590532-000
- DL10 590532-000
- DL11 590532-000

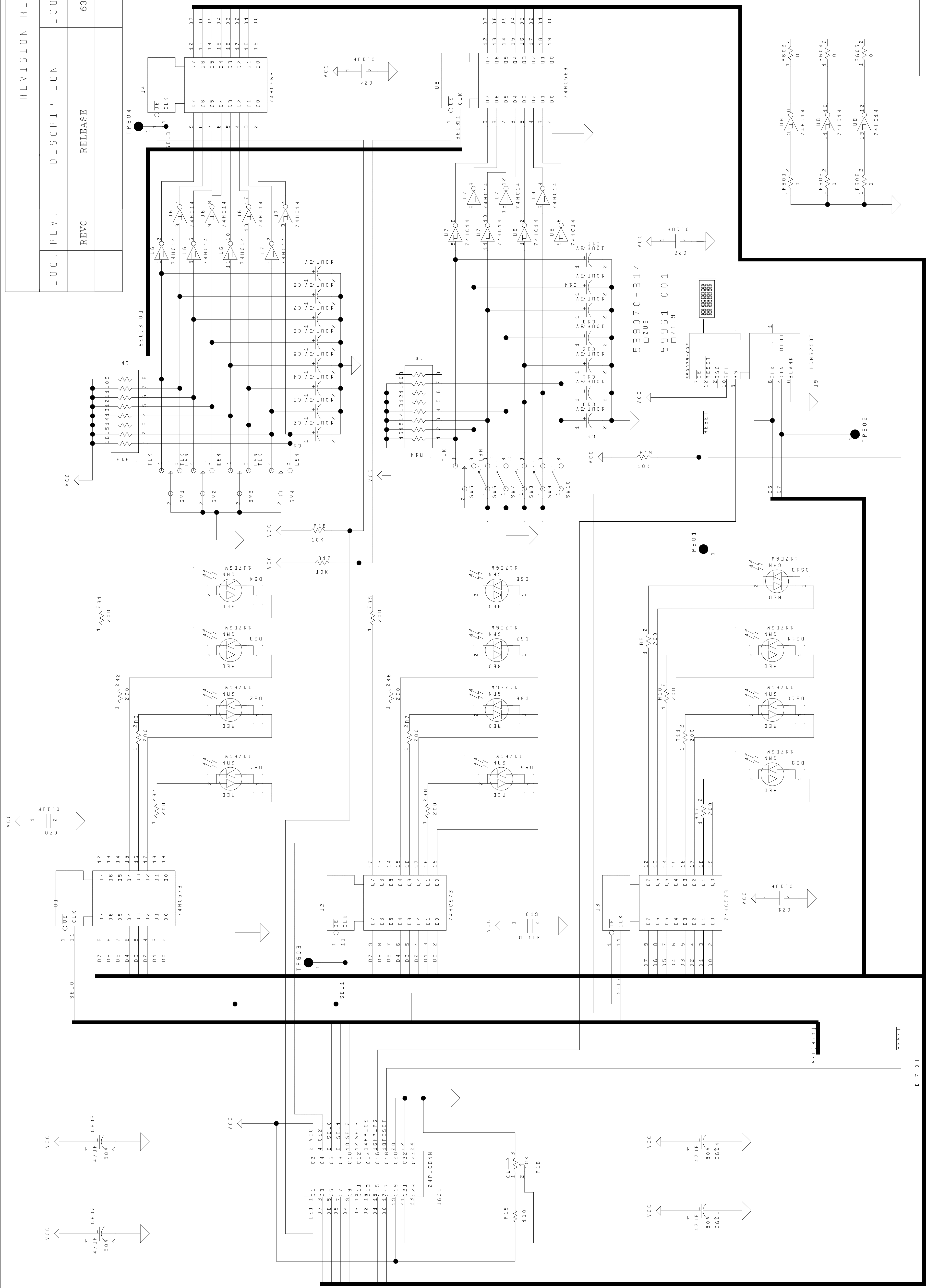

CAD GENERATED DRAWING
 FILENAME: IC_GROUP\SEM\MAT\0648\REV0648C

TELEX
 TELECOMMUNICATIONS, INC.
 MINNEAPOLIS, MINNESOTA

Zeus Key Panel
 Front Board
 SIZE DWG. NO. 90277646-000
 SHEET 1 OF 1 REV.

REVISION RECORD

LOC.	REV.	DESCRIPTION	ECD NO.	DRFT	CHKR	APP	DATE
	C	RELEASE	63639				02/02/99
	D	SEE ECO FOR CHANGES	63652				03/08/99
	F	BYPASS COMPRESSOR CIRCUIT	63825				10/8/99

NOT INSTALLED

MIKE LEVEL: -42dB

GAIN +18dbu

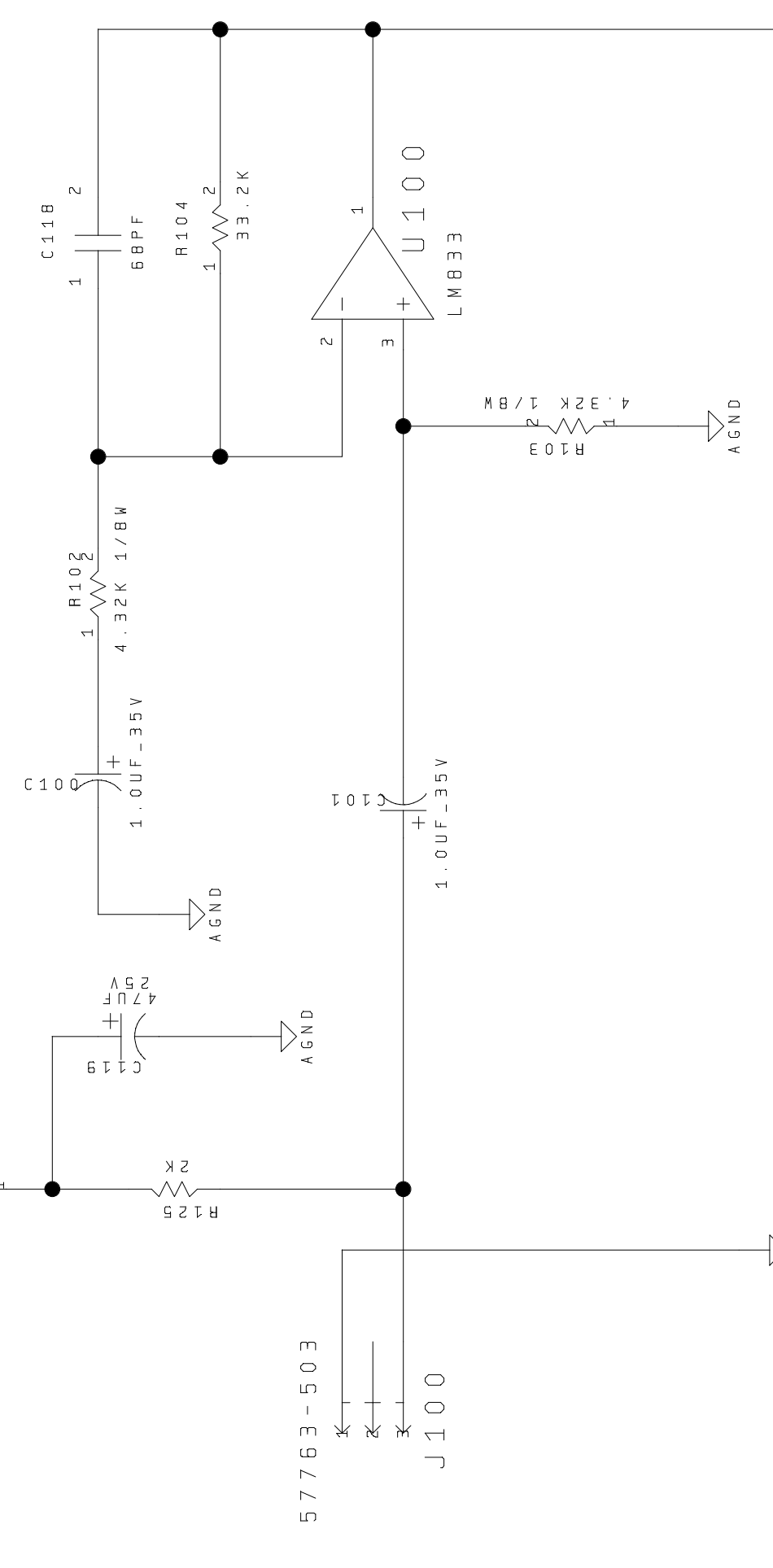

GOOSENECK MIKE INPUT

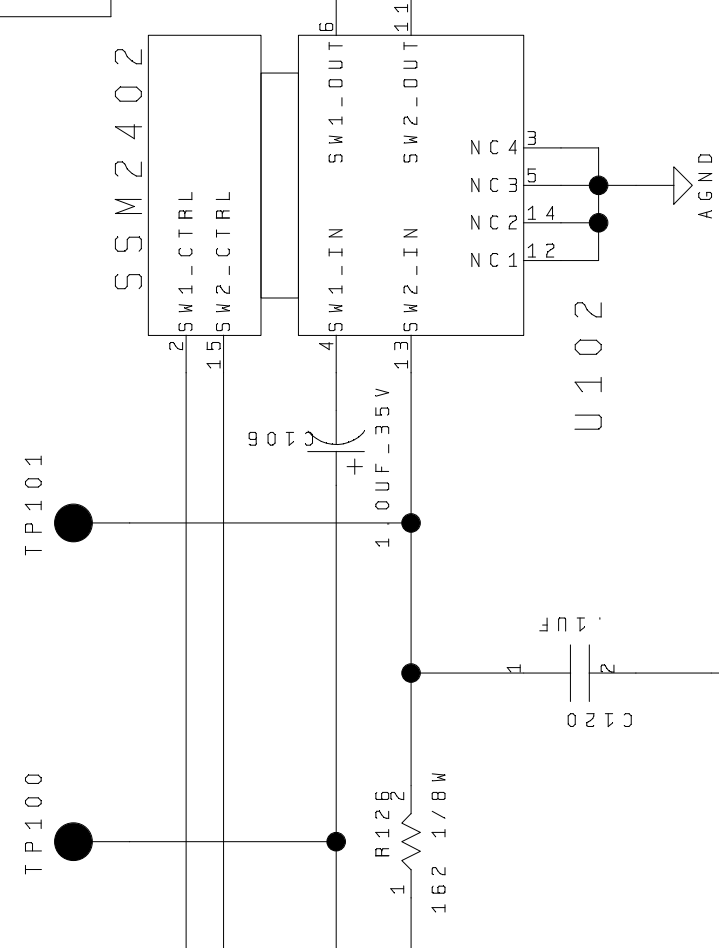

O/P LEVEL: -24db

O/P LEVEL: -24db

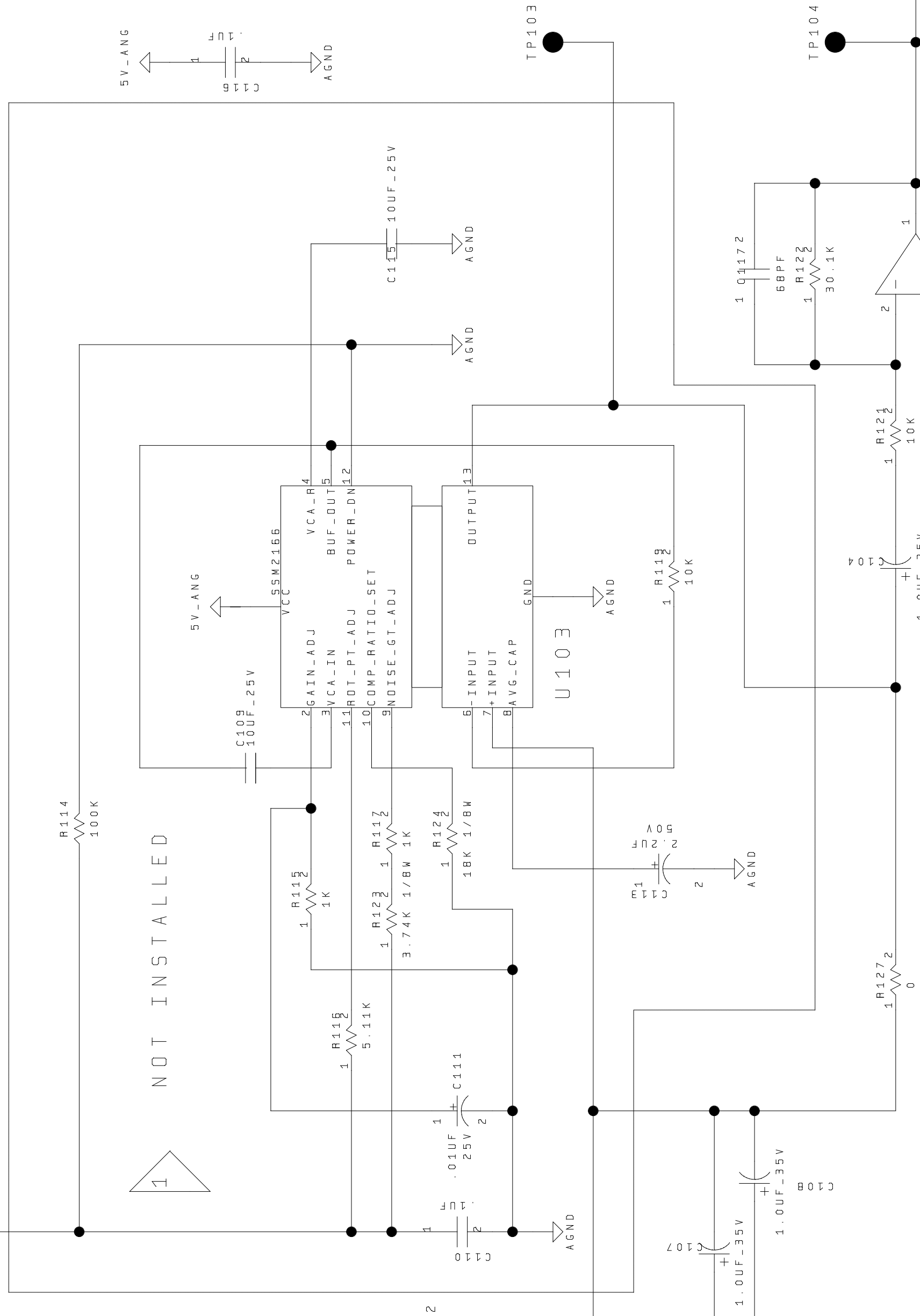

O/P LEVEL: -5.8 dbu

HEADSET LEVEL: -55db

GAIN +31dbu

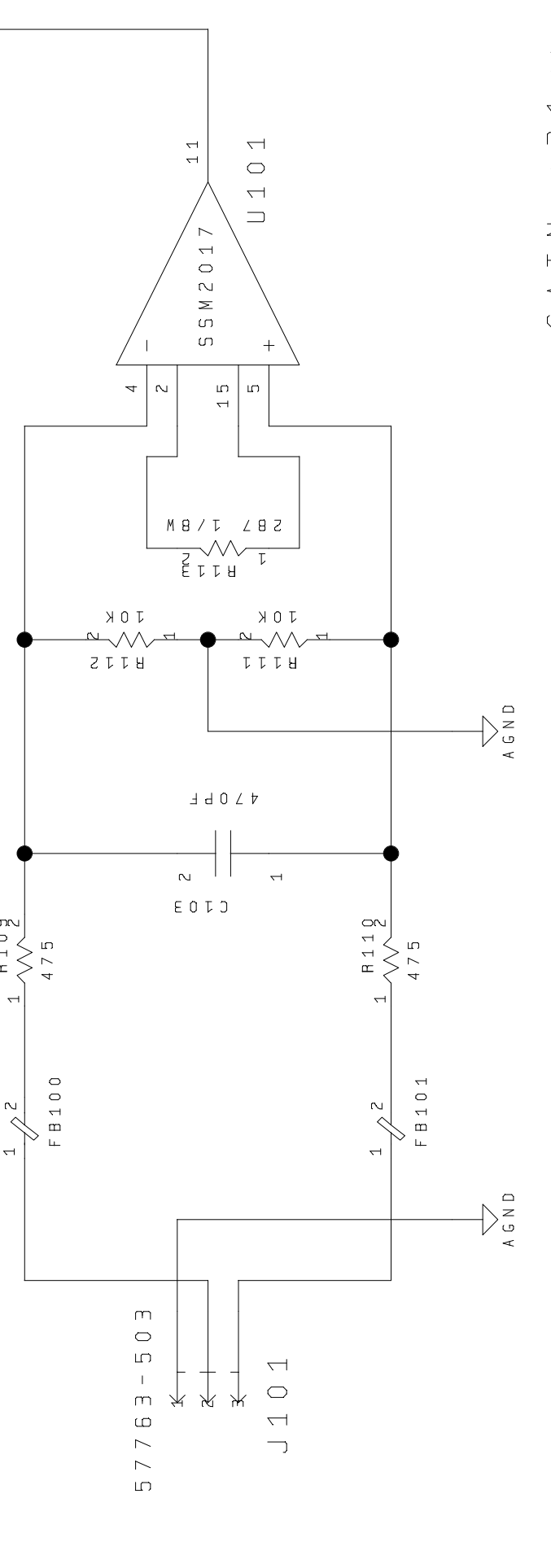

HEADSET MIKE INPUT

SWITCHING CKT

AUDIO COMPRESSOR CKT

CAD GENERATED DRAWING
FILENAME: C:\GROUP2\SCHEM\KEY\267\REV01\MAINBROD.DWG

DR.	E.K.	APP.	TITLE
GK			Zeus Key Panel
DATE	02/02/99		Mother Board
			TELEX
			TELECOMMUNICATIONS, INC.
			MINNEAPOLIS, MINNESOTA
SIZE	DWG. NO.		
	90277647-000		
	BHT.1	REV. 6	

AUDIO LEVELS AT 2161 I/P : 2dB

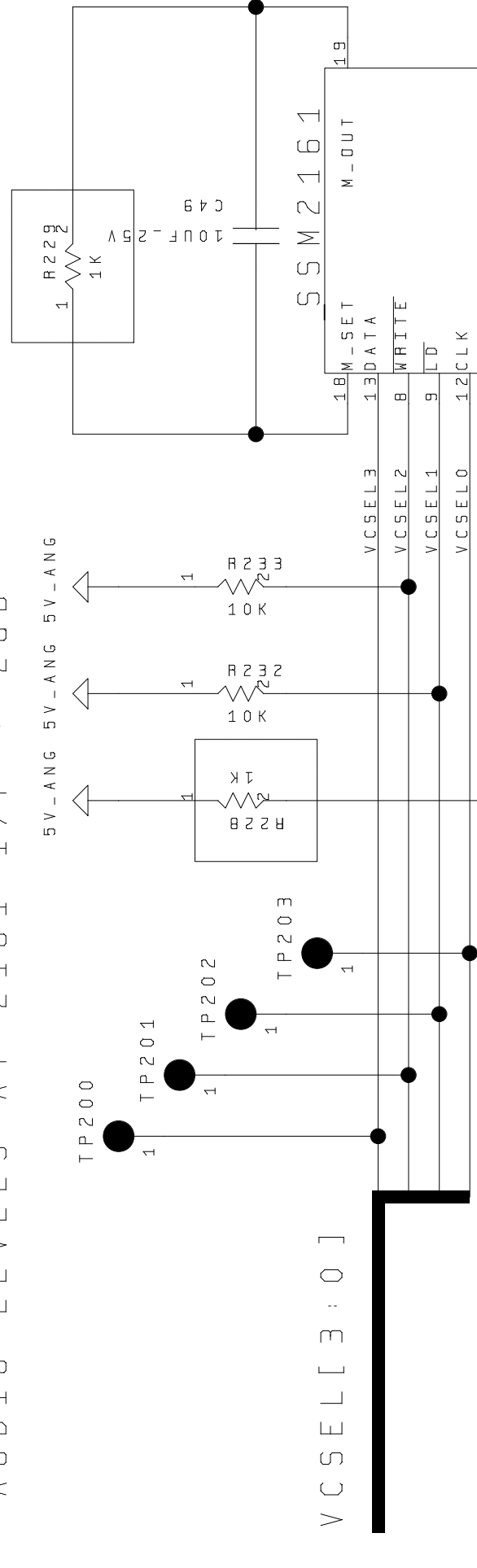

VCSEL[3:0]

GAIN: +17dB

GAIN: 0dB

GAIN: +17dB

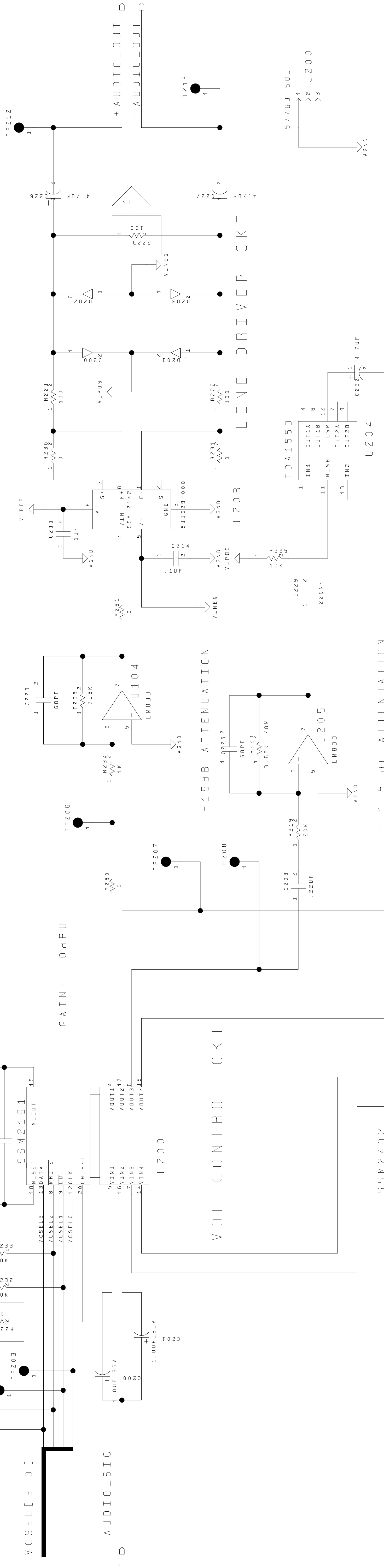

VOL CONTROL CKT

-15dB ATTENUATION

LINE DRIVER CKT

3 D SW2

3 D SW3

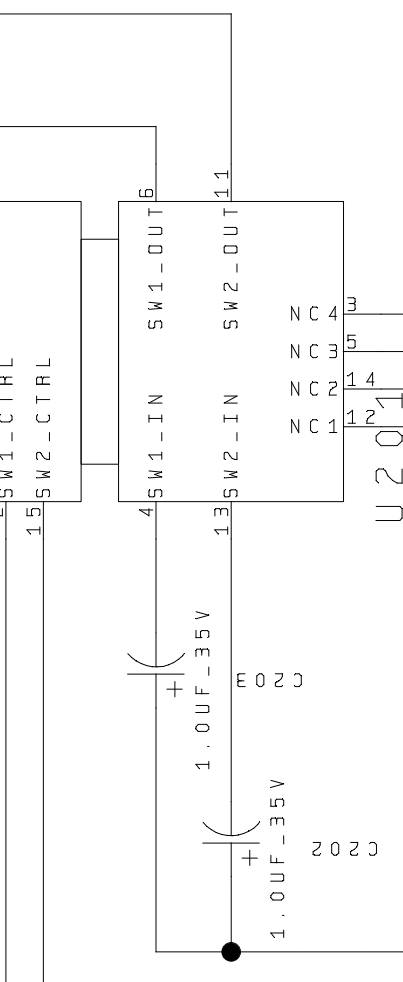

SELECTOR CIRCUIT

AUDIO: -14.5 dB

AUDIO: +8dB

SIDE TONE CKT

POWER AMPLIFIER CKT

- 1.5 db ATTENUATION

SPEAKER

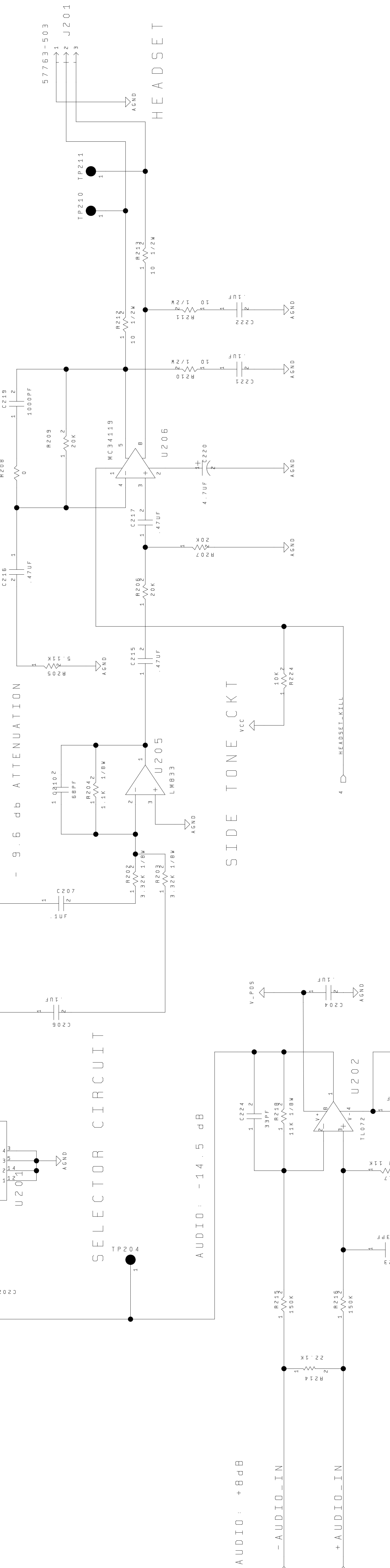

HEADSET

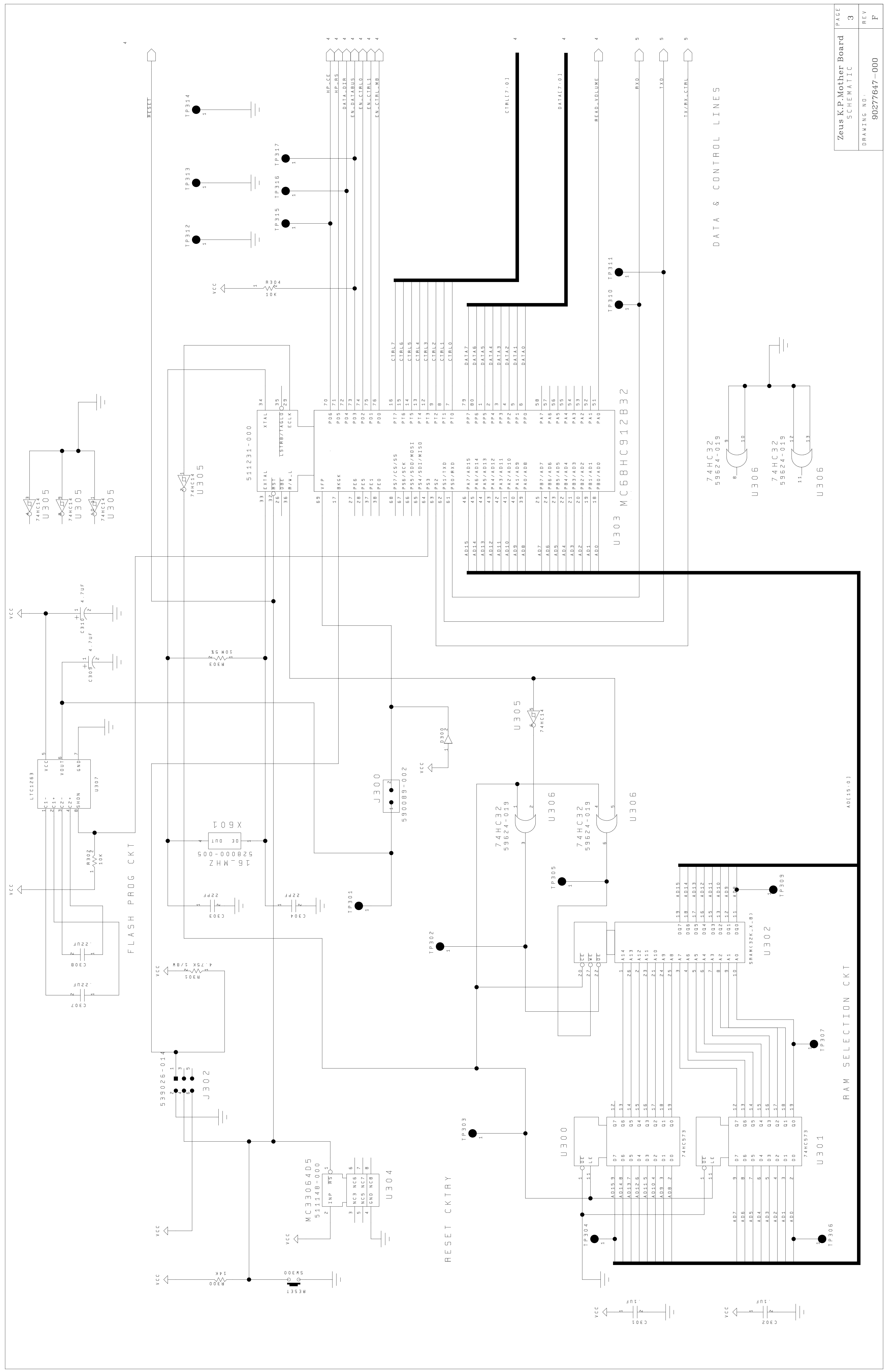

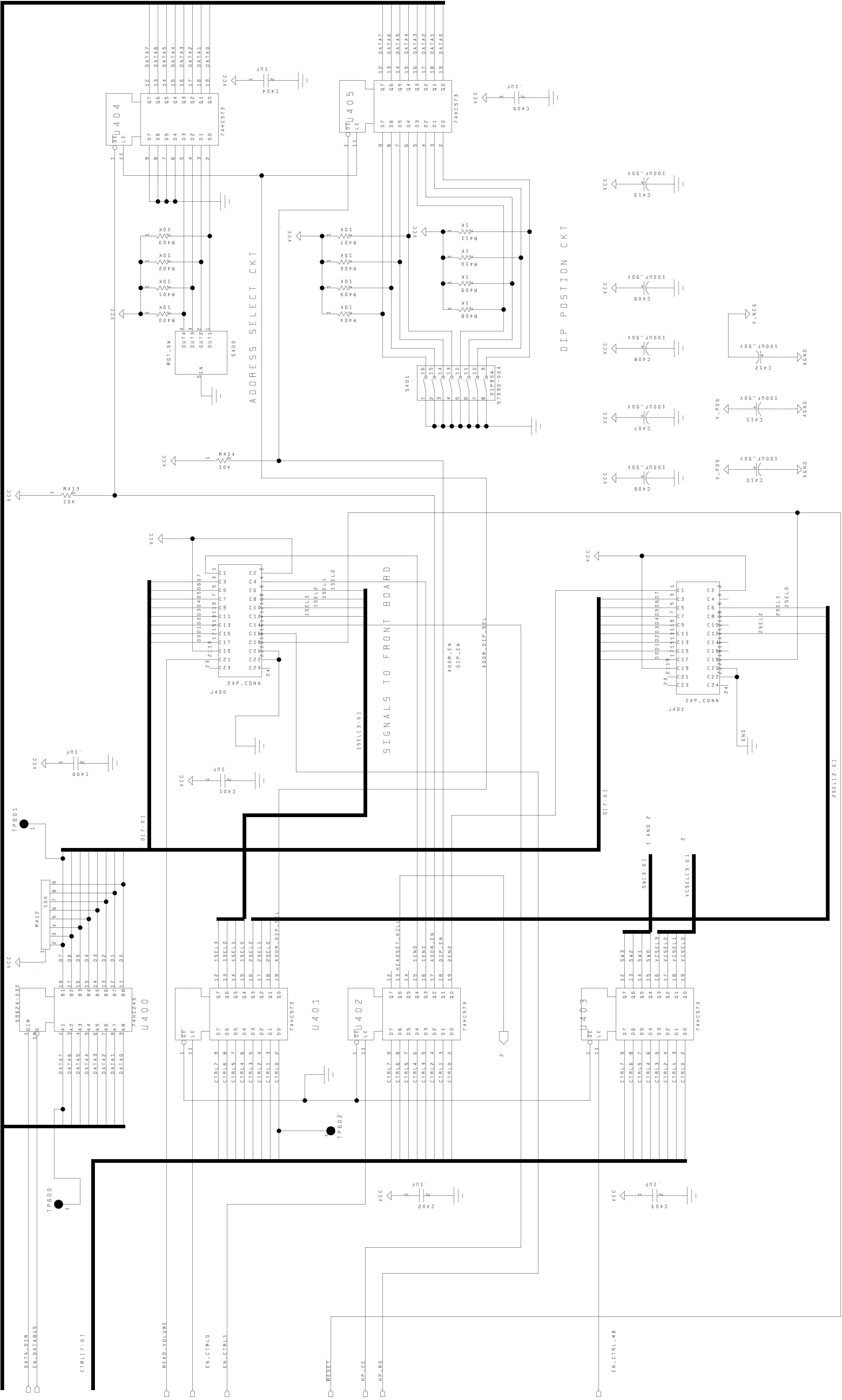

SIGNALS TO FRONT BOARD

CONNECTOR SELECT CKT

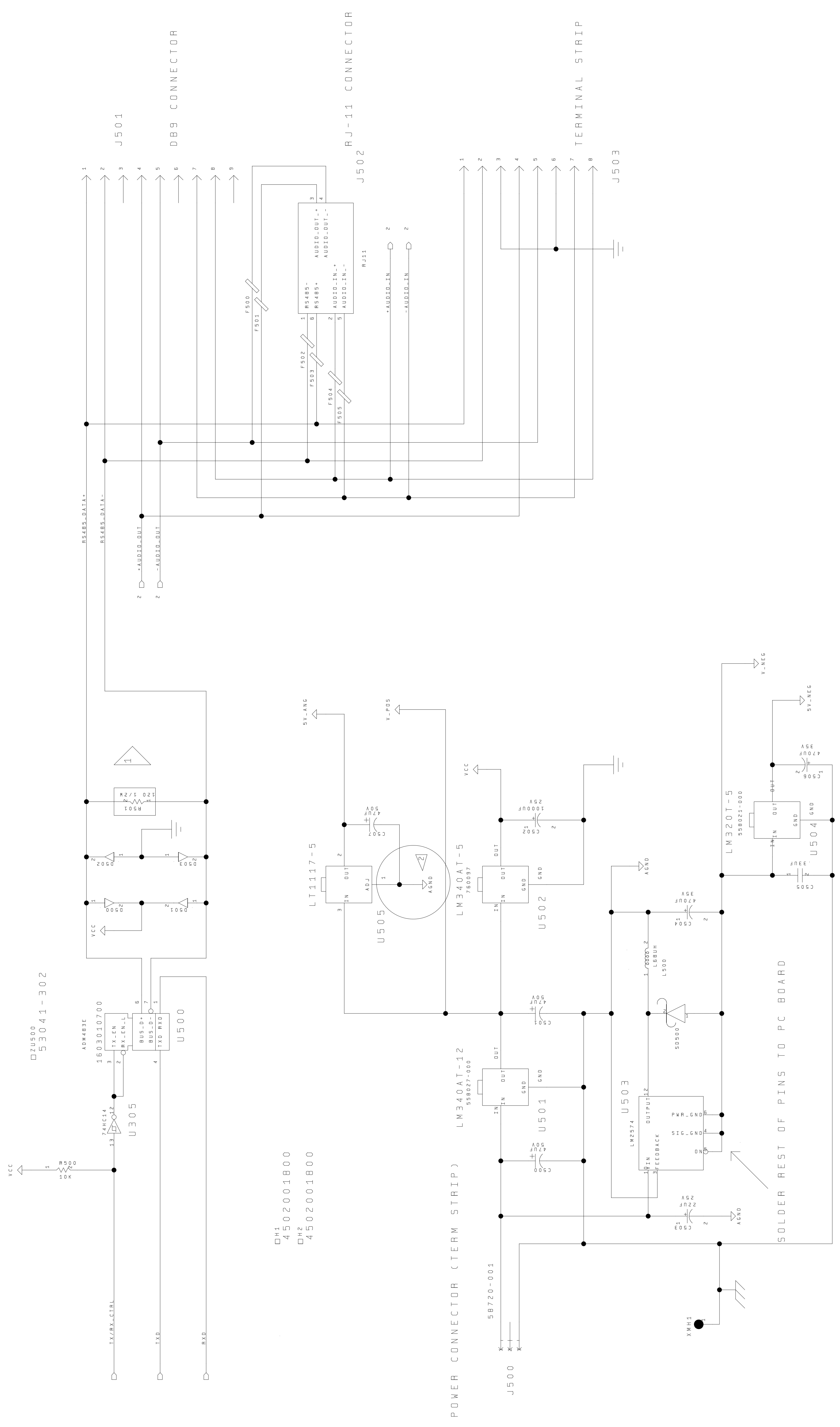

□ZU500
53041-302

□H1
4502001800
□H2
4502001800

POWER CONNECTOR (TERM STRIP)

SOLDER REST OF PINS TO PC BOARD

CONNECT GROUND OF + 5V_ANG TO A SEPARATE GROUND CONNECTION

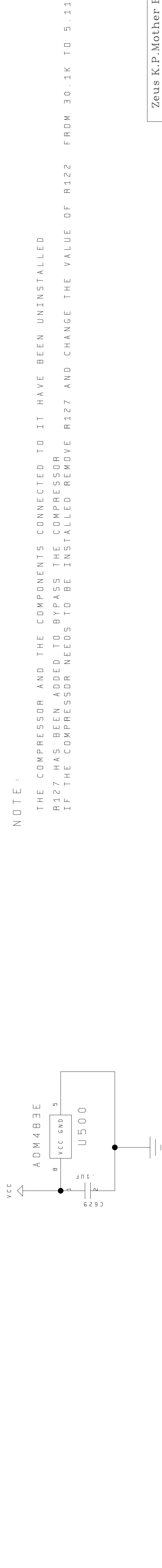
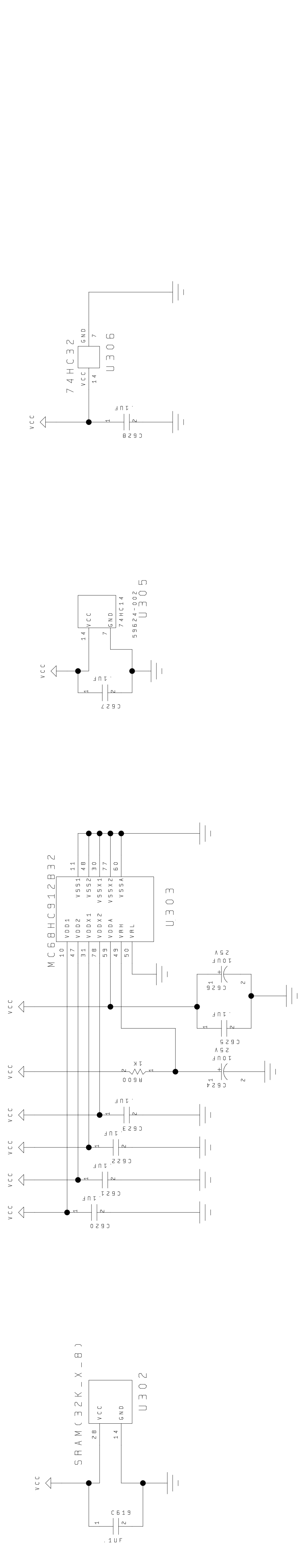
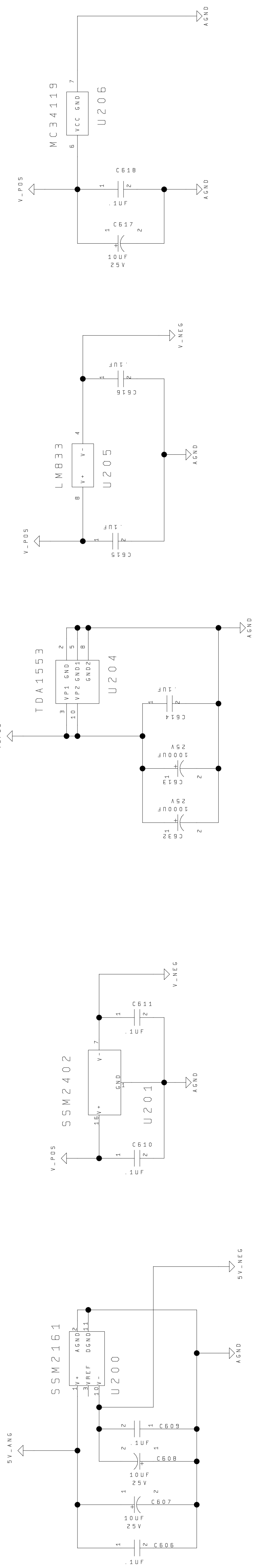
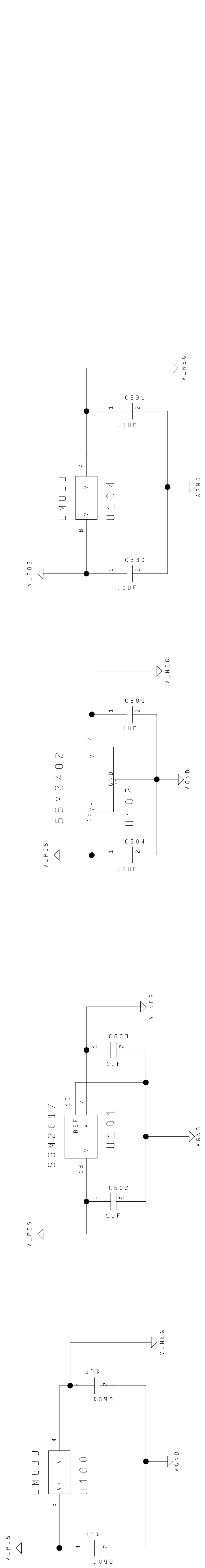

NOTE :

THE COMPRESSOR AND THE COMPONENTS CONNECTED TO IT HAVE BEEN UNINSTALLED

R127 HAS BEEN ADDED TO BYPASS THE COMPRESSOR

IF THE COMPRESSOR NEEDS TO BE INSTALLED REMOVE R127 AND CHANGE THE VALUE OF R122 FROM 30.1K TO 5.11k

Free Manuals Download Website

<http://myh66.com>

<http://usermanuals.us>

<http://www.somanuals.com>

<http://www.4manuals.cc>

<http://www.manual-lib.com>

<http://www.404manual.com>

<http://www.luxmanual.com>

<http://aubethermostatmanual.com>

Golf course search by state

<http://golfingnear.com>

Email search by domain

<http://emailbydomain.com>

Auto manuals search

<http://auto.somanuals.com>

TV manuals search

<http://tv.somanuals.com>