

Telex[®]

User Instructions

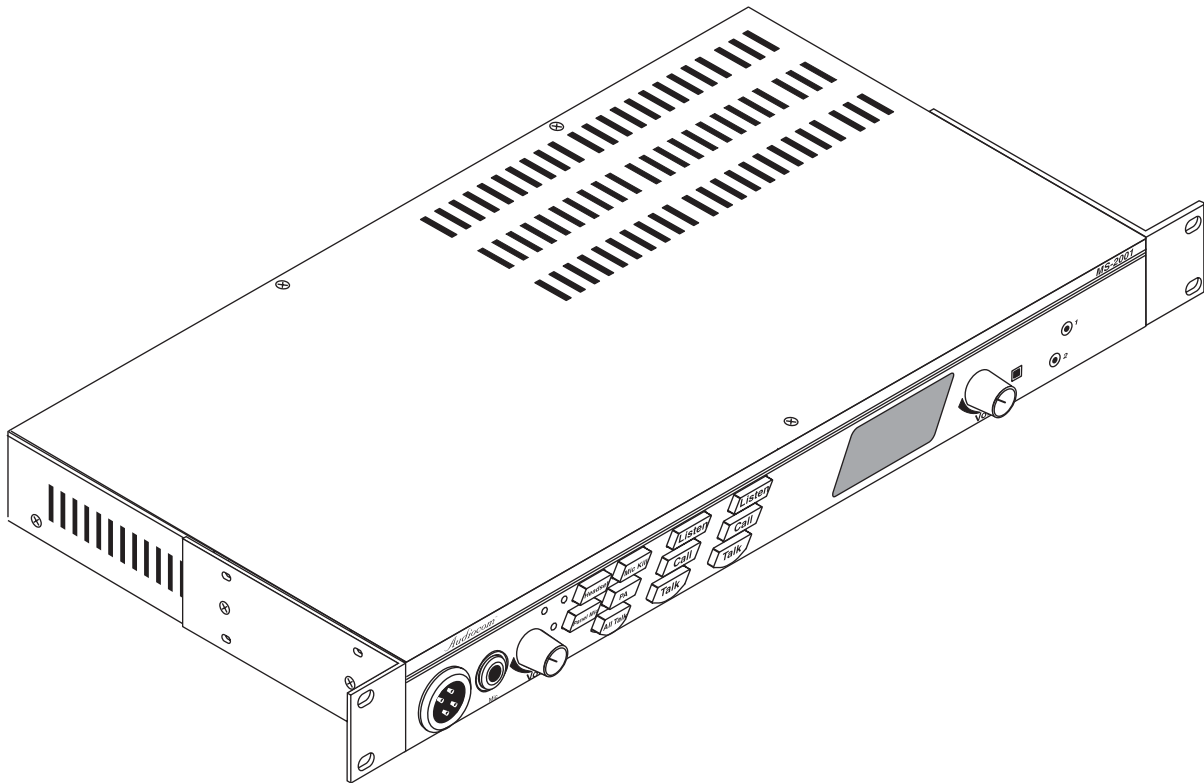

Model MS-2002 Master Station and Power Supply

Audiocom[®] Intercom Systems

9350-7749-000 Rev B, 10/2003

FCC Statement

This equipment uses, and can radiate radio frequency energy that may cause interference to radio communications if not installed in accordance with this manual. The equipment has been tested and found to comply with the limits of a Class A computing device pursuant to Subpart J, Part 15 of FCC Rules which are designed to provide reasonable protection against such interference when operated in a commercial environment. Operation of this equipment in a residential area may cause interference which the user (at his own expense) will be required to correct.

CE This product meets Electromagnetic Compatibility Directive 89/336/EEC

TRADEMARKS

Audiocom® is a registered trademark of Telex Communications. (*)Names of other products mentioned herein are used for identification purposes only and may be trademarks and/or registered trademarks of their respective companies.

WARRANTY INFORMATION

Products are warranted by Telex Communications, Inc. to be free from defects in materials and workmanship for a period of one year from the date of sale.

The sole obligation of Telex during the warranty period is to provide, without charge, parts and labor necessary to remedy covered defects appearing in products returned prepaid to Telex. This warranty does not cover any defect, malfunction or failure caused beyond the control of Telex, including unreasonable or negligent operation, abuse, accident, failure to follow instructions in the manual, defective or improper associated equipment, attempts at modification and repair not authorized by Telex, and shipping damage. Products with their serial numbers removed or effaced are not covered by this warranty.

To obtain warranty service, follow the procedures entitled "Procedure for Returns" and "Shipping to Manufacturer for Repair or Adjustment".

This warranty is the sole and exclusive express warranty given with respect to Audiocom products. It is the responsibility of the user to determine before purchase that this product is suitable for the user's intended purpose.

ANY AND ALL IMPLIED WARRANTIES, INCLUDING THE IMPLIED WARRANTY OF MERCHANTABILITY ARE LIMITED TO THE DURATION OF THIS EXPRESS LIMITED WARRANTY.

NEITHER TELEX NOR THE DEALER WHO SELLS TELEX PRODUCTS IS LIABLE FOR INCIDENTAL OR CONSEQUENTIAL DAMAGES OF ANY KIND.

CUSTOMER SUPPORT

Technical questions should be directed to:

Customer Service Department
Telex
12000 Portland Avenue South
Burnsville, MN 55337 U.S.A
Telephone: (952) 884-4051
Fax: (952) 884-0043

RETURN SHIPPING INSTRUCTIONS

Procedure for Returns

If a return is necessary, contact the dealer where this unit was purchased.

If a return through the dealer is not possible, obtain a RETURN AUTHORIZATION from:

Customer Service Department
Telex Communications, Inc.
Telephone: 1-800-392-3497 or (952) 884-4051
Fax: 1-800-323-0498 or (952) 884-0043

DO NOT RETURN ANY EQUIPMENT DIRECTLY TO THE FACTORY WITHOUT FIRST OBTAINING A RETURN AUTHORIZATION.

Be prepared to provide the company name, address, phone number, a person to contact regarding the return, purchase order number, the type and quantity of equipment, a description of the problem and the serial number(s).

Shipping to Manufacturer for Repair or Adjustment

All shipments of products should be made via United Parcel Service or the best available shipper prepaid. The equipment should be shipped in the original packing carton; if that is not available, use any suitable container that is rigid and of adequate size. If a substitute container is used, the equipment should be wrapped in paper and surrounded with at least four inches of excelsior or similar shock-absorbing material. All returns must include the return authorization number. Units sent for repair or adjustment **DO NOT** need a return authorization number

Factory Service department
Telex Communications, Inc.
West 1st Street
Blue Earth, MN 56013 U.S.A.

Upon completion of any repair the equipment will be returned via United Parcel Service or specified shipper collect.

Contents

Description	4
Features	4
Installation	6
Unpacking	6
Configuration Pre-check	6
Headset Microphone Type Selection DIP Switch	8
Mic Kill Send Enable DIP Switch	8
Program Interrupt DIP Switches	8
Incoming Call Beep DIP Switches	8
Monaural or Binaural Operation DIP Switches	8
Balanced/Unbalanced Switches	9
Direct Program Listen Enable / Disable Jumpers	9
Mounting	9
Connections	9
External Program Input and PA Output	9
Cables	10
Power-Up Check	16
Test Tone	16
Sidetone Adjustment	16
Voice-Activated Microphone (Vox) Setup	17
Operation	17
Public Address (PA)	19
Using Mic Kill	19
Using Voice-Activated Microphone (Vox)	19
Incoming Call Beep On/Off	19
Specifications	20
Quick Reference	23

Description

The MS-2002 is a complete 2-channel master station and system power supply (24 V DC, 2 Amps total power) in a single unit. You simply plug it into any AC power outlet from 100 to 240 volts, add a microphone or headset, connect intercom stations to the back panel, and you're ready to communicate. It even has both 1-channel and 2-channel connectors, so you don't have to add a separate breakout box if you want to mix 1-channel and 2-channel intercom stations. The MS-2002 fits in a standard 19-inch equipment rack and is 1 rack unit high. The basic MS-2002 can communicate with two intercom channels. This number can be increased by connecting optional EMS4001 Expansion Stations. Each EMS4001 adds four additional channels, and up to four of these expansion stations can be connected for a total of eighteen channels.

Features

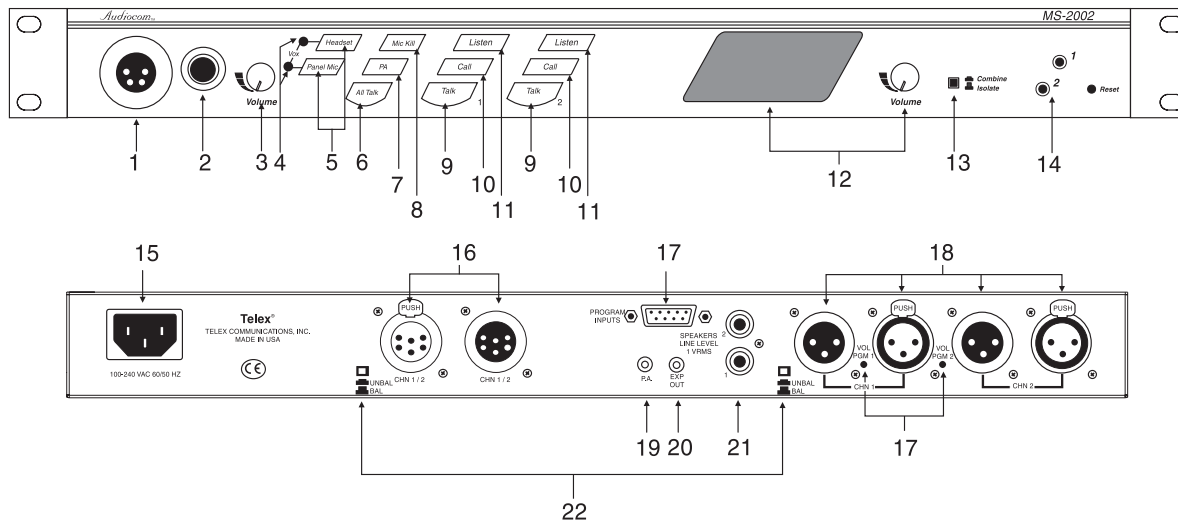

1. **DYNAMIC-MIC HEADSET CONNECTOR:** Accepts headsets with monaural headphones and either a balanced or unbalanced dynamic microphone.
2. **PANEL MIC / ELECTRET-MIC HEADSET CONNECTOR:** Accepts an electret gooseneck microphone, such as the Telex Model MCP-90-XX. The model MCP-90 series panel mic connector is a 1/4" stereo plug, with a threaded shaft for easy installation.
3. **VOLUME CONTROL:** Adjusts headphone volume only.
4. **VOX TRIMMERS:** Used with the voice-activated microphone feature. Separate trimmers adjust the voice activation level for the headset and panel microphones.
5. **HEADSET AND PANEL MIC KEYS:** Used to manually activate either the headset or panel microphone, whichever is being used.
6. **ALL TALK KEY:** Used to talk to all stations that are listening on all channels. This includes both MS-2002 channels and all channels of any connected EMS4001 Expansion Stations.
7. **PA KEY:** If the MS-2002 is connected to a public address system, this key may be used to talk over the public address system.
8. **MIC KILL KEY:** Used to turn off the microphones on any intercom stations on a channel. Also used to activate the program inputs and the audible beep feature for incoming calls.
9. **INTERCOM TALK KEYS:** Momentary or latching (hands-free) operation possible.

10. **CALL KEYS:** Used to place calls on intercom channels and to indicate incoming calls.
11. **INTERCOM LISTEN KEYS:** Momentary or latching operation possible.
12. **SPEAKER VOLUME CONTROL:** The Volume control adjusts the level to the front panel speaker. If an external speaker is used, volume must be adjusted at the external speaker.
13. **COMBINE / ISOLATE SWITCH:** This recessed, pushbutton switch lets you combine the audio signals of the two channels to create a single audio channel where all users can intercommunicate. Or, you can isolate each channel to create two groups of completely independent users. For normal operation, it should be set in the isolate position.
14. **CHANNEL STATUS INDICATORS AND RESET PUSHBUTTON:** The indicators are green for normal operation and red when there is an overload or short circuit. The Reset pushbutton restores normal operation after the short-circuit or overload has been located and fixed.
15. **UNIVERSAL AC POWER INPUT:** The MS-2002 accepts any input power in the range of 100-240 VAC, 50/60 Hz.
16. **2-CHANNEL INTERCOM CABLE CONNECTORS:** One male and one female XLR-6 connector for 2-channel operation with SS2002, BP2002, etc.
17. **PROGRAM INPUTS CONNECTOR AND TRIMMERS:** Each intercom channel has its own program input and level adjust trimmer. The program inputs may be turned on or off via the front panel and they may be set to interrupt during talk, if desired.
18. **1- CHANNEL INTERCOM CABLE CONNECTORS:** Two connectors are provided for each channel for loop-through connection of 1-channel intercom stations, such as the SS1002, BP1002, etc.
19. **PA OUTPUT:** Connects to a public address system.
20. **EXPANSION OUT CONNECTOR:** Connects to an EMS4001 Expansion Station.
21. **SPEAKER OUTPUT JACKS:** May be used with external, powered loudspeakers for monaural or binaural listening configurations.
22. **BALANCED / UNBALANCED SELECTOR SWITCHES:** The selector switches sets the MS-2002 for compatibility with either Audiocom or Clear-Com* channel connector pin-outs, channel power requirements, and call signaling requirements. Both switches must be in the same position.

Installation

Unpacking

The package contains the following items. Contact the shipper or your Audiocom dealer immediately if anything is damaged or missing. Detach and fill out the registration card and return it to Telex to properly register your MS-2002.

Qty	Description
1	MS-2002 Master Station and Power Station
1	Warranty and Registration Card
1	User Manual
2	Black Face Plates

WARNING

The following instructions are for use by qualified personnel only. To avoid electric shock, do not remove the cover unless you are qualified to do so.

AVERTISSEMENT

Les instructions qui suivent s'adressent uniquement a un technicien qualifie. Pour evite des chocs electriques, ne pas ouvrir le boitier, a moins d'y entre habilité.

Configuration Pre-check

Before connecting the MS-2002 make sure that it is properly configured for your intended usage. Figure 2 shows the locations of the configuration switches. To access internal switches, remove three screws from the top cover and three screws from the bottom portion of each side.

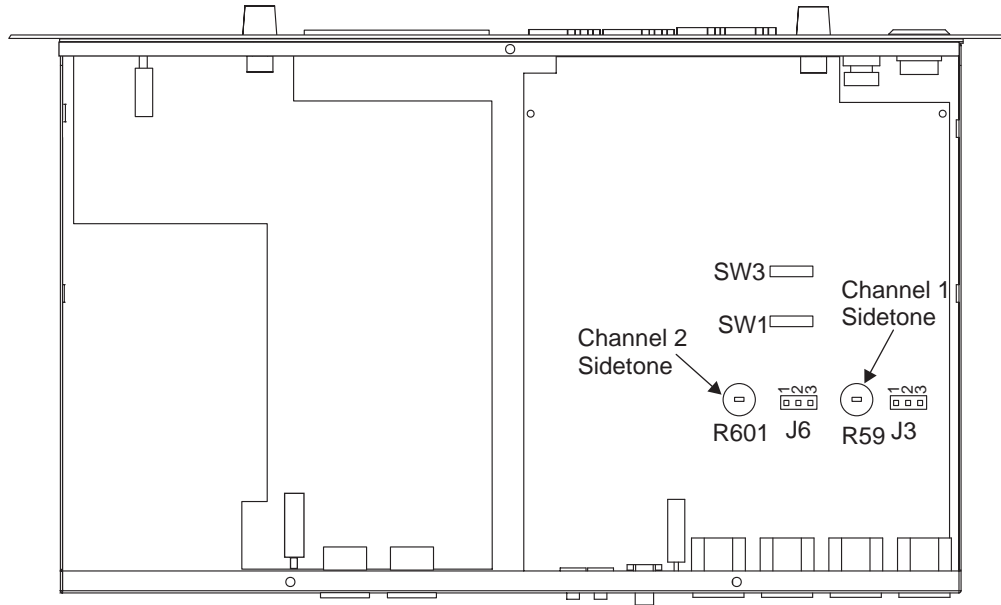

Figure 2 - Locations of Configuration Jumpers and Switches

Switch #	Description	Settings	Default
DIP SWITCH SW1 (INTERNAL)			
SW1-1	Headset microphone type	On: Unbalanced Off: Balanced (Typical)	Off
SW1-2	Call signal send, channel 1	On: Enabled Off: Disabled	On
SW1-3	Call signal receive, channel 1	On: Enabled Off: Disabled	On
SW1-4	Call signal send, channel 2	On: Enabled Off: Disabled	On
SW1-5	Call signal receive, channel 2	On: Enabled Off: Disabled	On
SW1-6	Mic kill signal send	On: Enabled Off: Disabled	Off
SW1-7	Program 2 interrupt	On: Interrupt during talk Off: No interrupt	Off
SW1-8	Program 1 interrupt	On: Interrupt during talk Off: No interrupt	Off
BALANCED (BAL) - UNBALANCED (UNBAL) OPERATION BOTH SWITCHES MUST BE SET THE SAME. FACTORY DEFAULT IS BALANCED.			
Rear Panel	Audiocom or Clear-Com operation	Out: Balanced (Audiocom) In: Unbalanced (Clear-Com)	Out (BAL)
Rear Panel	Audiocom or Clear-Com operation	Out: Balanced (Audiocom) In: Unbalanced (Clear-Com)	Out (BAL)
DIP SWITCH SW3 (INTERNAL) *SET ALL TO MONAURAL OR ALL TO BINAURAL			
SW3-1	Incoming call beep, headset	On: Disabled Off: Enabled	Off
SW3-2*	Listen 1 to speaker 1 only	On: Enabled (Binaural) Off: Disabled (Monaural)	Off
SW3-3	Incoming call beep, speaker 1	On: Enabled (SW3-1 must be off) Off: Disabled	Off
SW3-4	Incoming call beep, speaker 2	On: Enabled (SW3-1 must be off) Off: Disabled	Off
SW3-5	Listen 2 to right headphone	On: Enabled (Monaural) Off: Disabled (Binaural)	On
SW3-6	Listen 2 to speaker 2	On: Enabled (Binaural) Off: Disabled (Monaural)	Off
SW3-7	Listen 2 to speaker 1	On: Enabled (Monaural) Off: Disabled (Binaural)	On
SW3-8	Listen 1 to left headphone	On: Enabled (Monaural) Off: Disabled (Binaural)	On

Table 1 - Configuration Switch Settings

Headset Microphone Type Selection DIP Switch

SW1-1 applies only to a dynamic-mic headset connected to the dynamic-mic headset jack on the front panel. If the headset specifications indicate the microphone type is balanced, or if you are unsure, leave this switch in the off (default) position. If the specifications indicate an unbalanced microphone set SW1-1 to on.

Note: For best results in noisy environments, a noise canceling (directional or cardioid) microphone is highly recommended. This is especially true if you are using the Vox feature.

Mic Kill Send Enable DIP Switch

The MS-2002 can generate an inaudible signal which will turn off the microphones on all intercom stations on a channel (for stations that detect this signal). This feature is useful, for example, when an unattended microphone has been left on and is causing unnecessary noise on a channel. By default, Mic Kill is not enabled. To activate this feature set SW1-6 to the on position.

Program Interrupt DIP Switches

If you plan on using external program sources with the MS-2002, you have a choice of whether or not you want the program audio to shut off on the intercom channel while you are talking. By default, program audio does not interrupt during talk. You can change this as follows:

1. For channel 1 program interrupt during talk, set SW1-7 to on .
2. For channel 2 program interrupt during talk, set SW1-8 to on .

Incoming Call Beep DIP Switches

If call signal receive is enabled (switches SW1-3 and SW1-5), incoming calls will be indicated by red-flashing Call keys. An optional beep tone can also be used. Internal switches enable the beep tone. You can then turn the beep tone on or off via the front panel during normal operation. Enable the beep tone as follows:

1. Make sure the call signal receive DIP switches are on (SW1-3 and SW1-5).
2. For incoming call beep in a headset, set SW3-1 to off.
3. For incoming call beep in speaker 1, set SW3-1 to off and SW3-3 to on.
4. For incoming call beep in speaker 2, set SW3-1 to off and SW3-4 to on.
5. The procedure to turn incoming call beep on or off during operation can be found on page .

Monaural or Binaural Operation DIP Switches

The MS-2002 can be used with a single speaker or monaural headphones (single- or double-sided) for monaural operation. In this case, all audio signals are combined and sent to the headphones and the front panel speaker. The combined signals also go to the Speaker 1 jack on the back panel. The MS-2002 can also be used with two speakers for binaural operation. In this case, channel 1 is sent to the Speaker 1 jack and channel 2 is sent to the Speaker 2 jack. Binaural headphone operation is not supported.

For monaural operation with headphones or one speaker (factory default):

1. Set SW3-2 to off.
2. Set SW3-5 to on.
3. Set SW3-6 to off.
4. Set SW3-7 to on.
5. Set SW3-8 to on.

For binaural operation with two speakers:

1. Set SW3-2 to on.
2. Set SW3-5 to off.
3. Set SW3-6 to on.
4. Set SW3-7 to off.
5. Set SW3-8 to off.

Balanced/Unbalanced Switches

Both of the BAL - UNBAL Switches on the back panel are set at the factory to the balanced (BAL) position for use with Audiocom intercom channels. Set the switches to the unbalanced (UNBAL) position for use with a Clear-Com intercom systems.

Direct Program Listen Enable / Disable Jumpers

By default, each MS-2002 program input can be heard by all intercom stations that are listening on the corresponding intercom channel. This includes the MS-2002. Program input routing to the intercom channels can be turned on or off via the MS-2002 front panel programming. (See “Turning the Program Inputs On and Off”, page .) Additionally, all program signals can be routed directly to the MS-2002 speaker or headset. This lets the MS-2002 operator hear the program inputs even if they are not being routed to the intercom channels. To disable direct program listening in the speaker or headset for one or more program inputs, reset the appropriate jumper as shown in Table 2.

Jumper	Description	Settings for Jumpers
J3	Program 1 direct to Headset or Speaker	Pins 2&3 Shorted: Enabled Pins 1&2 Shorted: Disable
J6	Program 2 direct to Headset or Speaker	Pins 2&3 Shorted: Enabled Pins 1&2 Shorted: Disable

Table 2 - Direct Program Listen Enable / Disable Jumpers

Mounting

The MS-2002 mounts in a standard 19 inch equipment rack and is 1 rack unit high. When mounting the MS-2002 install the supplied black face plates on the appropriate side. The face plates should be mounted with the groves on the top.

Note: You will have to perform the sidetone adjustment (page) after all components are connected. With the MS-2002 being rack mounted, you may not be able to access the sidetone trimmers. In this case, you can position the MS-2002 in the rack and make all required connections. Then, adjust the sidetone trimmers before installing and tightening all rack mount screws.

Connections

Refer to the following paragraphs, and the sample connection drawings shown in Figures 3 through 7, starting on page 10.

External Program Input and PA Output

Connections for external program input and PA output are shown in Figure 6, page 13. EMS4001 Expansion Station Connection (Optional Component)

Refer to the EMS4001 User Instruction Manual for detailed connection information.

Cables

The numbers below correspond to the cable numbers in the connection drawings on the following pages.

1. 1-channel intercom cable. Sold separately. Use Telex "ME" cables, below. Or, build per Figure 7, page 14.
ME-25: 25' (7.6 m) cable with Male and Female 3-pin XLR connectors.
ME-50: 50' (15.2 m) cable with Male and Female 3-pin XLR connectors.
ME-100: 100' (30.4 m) cable with Male and Female 3-pin XLR connectors.

☞ When connecting from the MS-2002 to a TW-7W, keep cables as short as possible. Also, heavier gage wire is recommended.
2. 2-channel intercom cable. Sold separately. Use Telex "ME /2" cables, below. Or, build per Figure 7, page 14.
ME-25/2: 25' (7.6 m) cable with Male and Female 6-pin XLR connectors.
ME-50/2: 50' (15.2 m) cable with Male and Female 6-pin XLR connectors.
ME-100/2: 100' (30.4 m) cable with Male and Female 6-pin XLR connectors.
3. Y adapter cable. Sold separately. Use Telex CA-23-16. Or, build per Figure 7, page 14.
4. 3 ft (0.91 m) speaker cable with RCA plugs. One supplied with each SPS2001, and SPK-2000.
5. 18" (457 mm) EXP IN/OUT cable, stereo miniplug to stereo miniplug. One supplied with each EMS4001.
6. 18" (457 mm) CHANNEL OUTPUT cable, 15-pin Male Dsub to 15-pin Male Dsub. One supplied with each EMS4001. (Optional component. See EMS4001 User Manual for connection information.)
7. Shielded patch cable, 9-pin Male Dsub to 9-pin Female Dsub. Customer local purchase: available at Radio Shack, etc. Note: All pins must be connected straight through: do not use an RS232 computer cable!
8. Shielded patch cable, stereo miniplug to stereo miniplug. Customer local purchase. Available at Radio Shack, etc.
9. Shielded audio cable. Must have male 3-pin XLR connector at one end for connection to the XP-USPG or XP-4PGM program inputs. Pin-out for program inputs is as follows:
Pin 1: common
Pin 2: + program input
Pin 3: - program input
10. Shielded audio cable. Must have male 3-pin XLR connector at one end for connection to the XP-USPG PA output. Pin-out for PA output is as follows:
Pin 1: common
Pin 2: + PA output
Pin 3: - PA output
11. 18" (457 mm) CHANNEL OUTPUT cable, 15-pin Male Dsub to 15-pin Female Dsub. One supplied with each XP-ES4000A. (Optional component. See EMS4001 User Manual for connection information.)

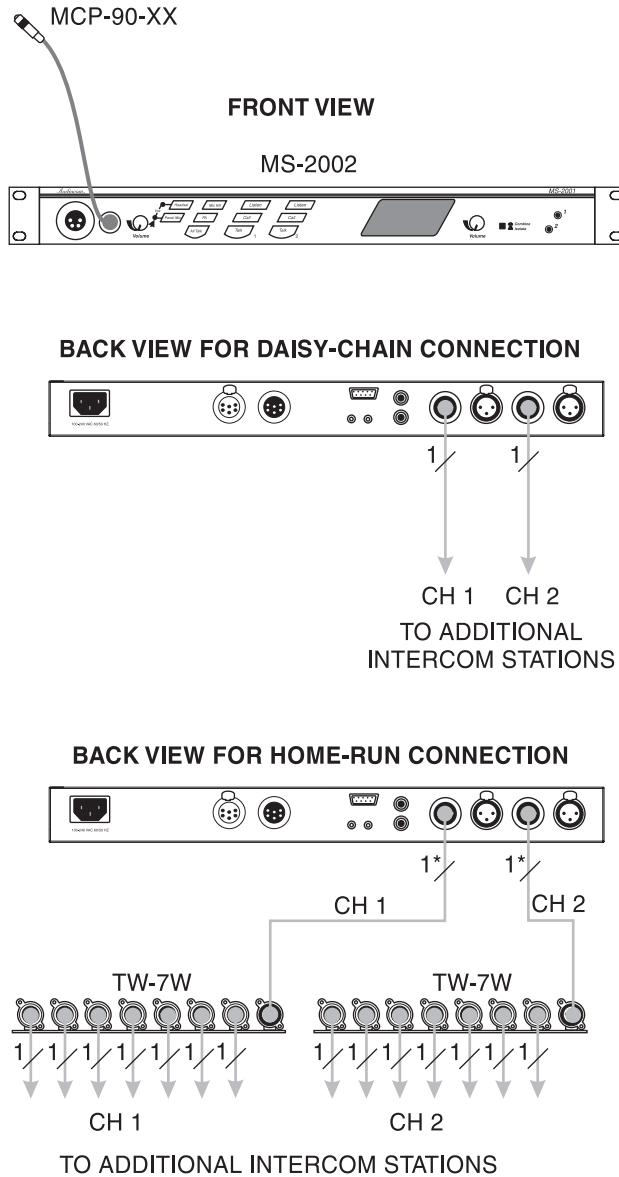
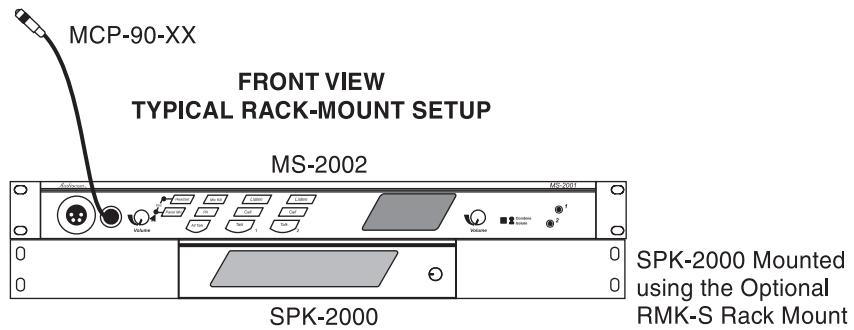
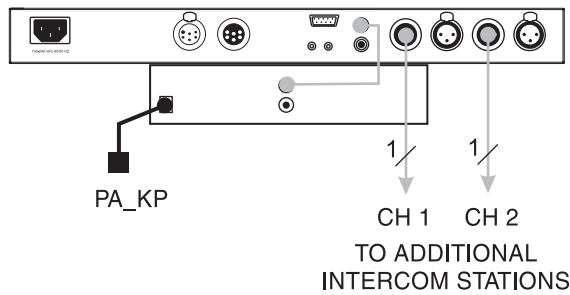

Figure 3 - MS-2002 Monaural Master Speaker Station Configuration.

This is a good configuration for smaller intercom systems when you want to operate the MS-2002 as a master speaker station, with one speaker to monitor both intercom channels. In this configuration, the Combine/Isolate switch is set to the Isolate position. With this setting the 2 intercom channels are completely separated. The MS-2002 dip switches are set to monaural operation so that both intercom channels are heard in the speaker.



BACK VIEW FOR DAISY-CHAIN CONNECTION



BACK VIEW FOR HOME-RUN CONNECTION

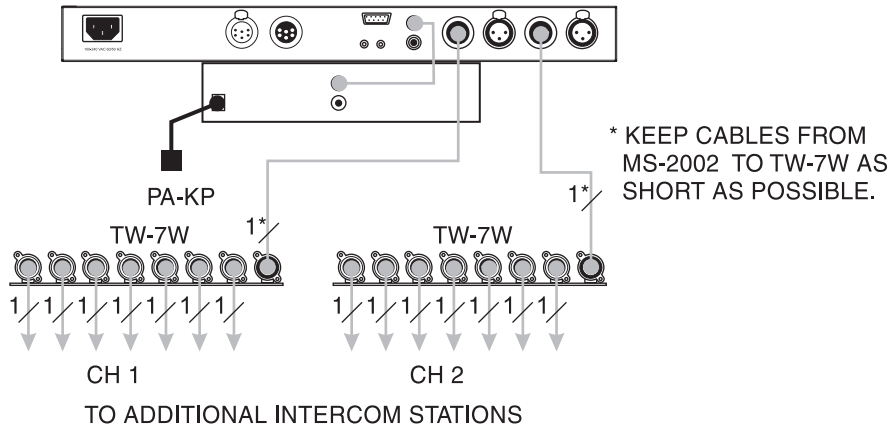

Figure 4 - MS-2002 Binaural Master Speaker Station Configuration.

This is a good configuration for smaller intercom systems when you want to operate the MS-2002 as a master speaker station, with a separate speaker for each intercom channel. Make sure the MS-2002 internal DIP switches are set for binaural speaker operation as described on page 7. Also, set the Combine/Isolate switch to the Isolate position. With this setting the two intercom channels are completely separated. The internal amplified speaker is used as the speaker output for channel 1, and the SPK-2000 is used for channel 2.

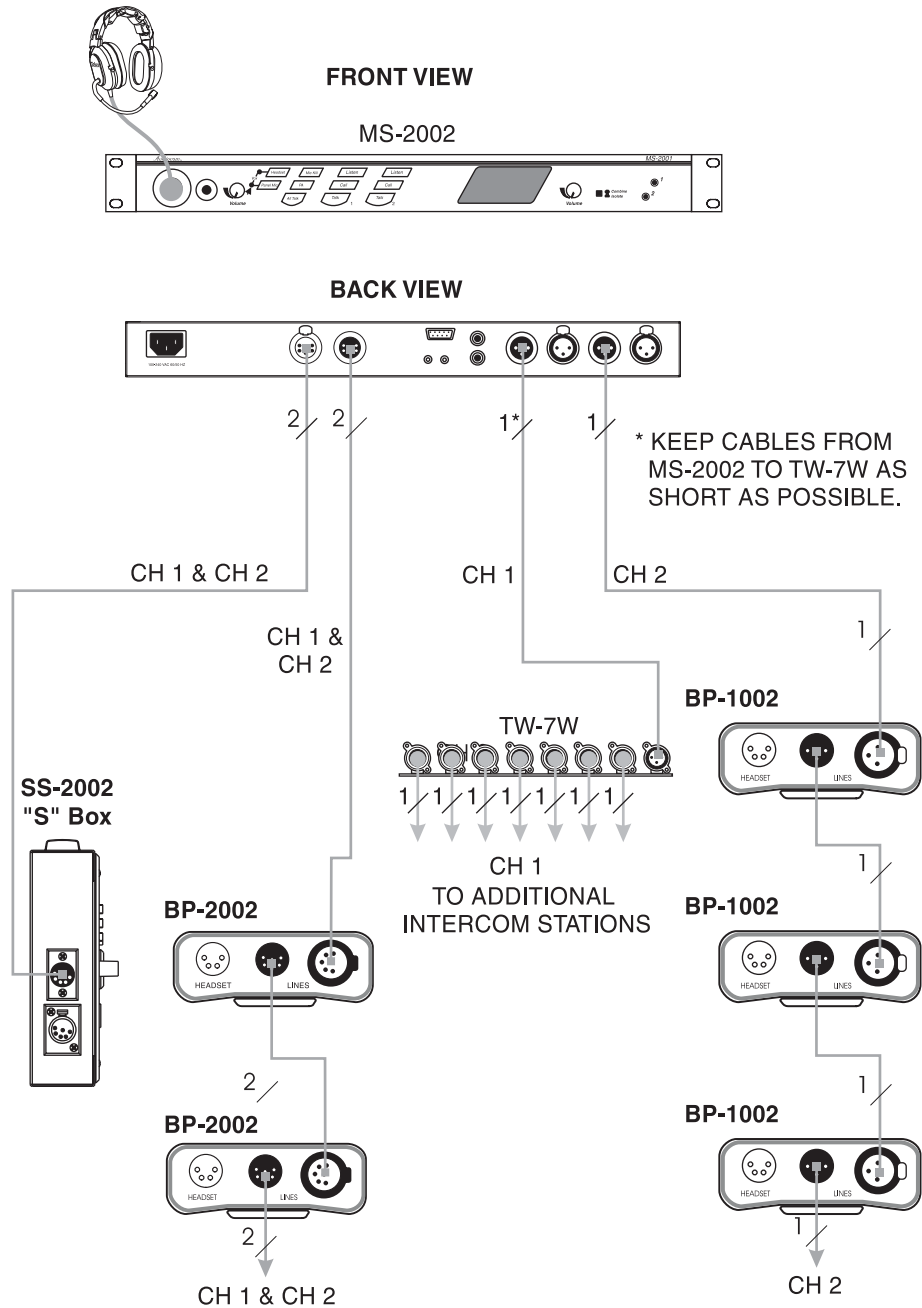

Figure 5 - MS-2002 typical Speaker Station and Belt Pack Connections.

Typically, a headset is connected to the front panel of the MS-2002, and the DIP switches are set to the monaural operation (default setting) so that both intercom channels as heard in the monaural headphones (binaural headphone operation is not supported). Note that belt packs use less power than speaker stations, and you can daisy-chain more of them on a single cable run. Avoid very long cable runs with daisy-chained speaker stations. This example shows how you would "home run" an SS2002 speaker station when the cable is very long. Also, set the Combine/Isolate switch to the Isolate position. With this setting the 2 intercom channels are completely separated.

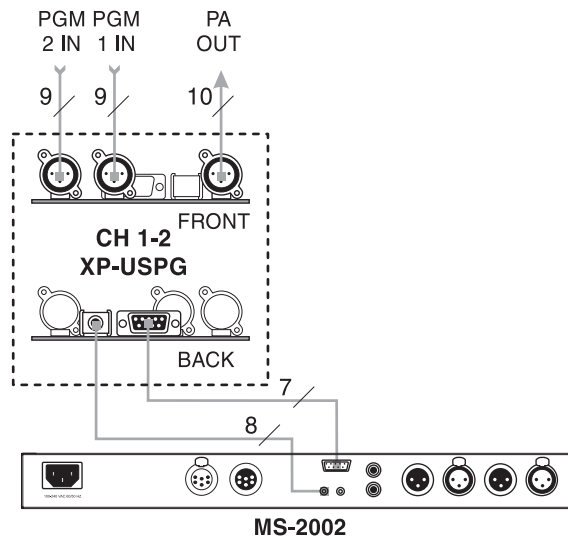
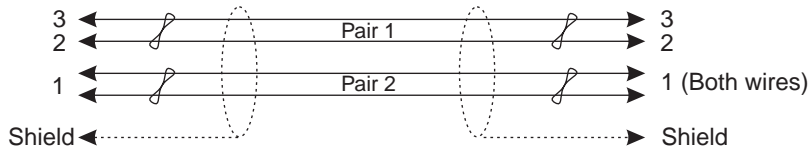

Figure 6 - External Audio Input and PA Output.

You can connect two audio sources to the Program Inputs connector: one for each channel. Audio sources can be directly connected with a user-supplied DB9M connector. (Refer to the program input connector specifications, located on page 20, for connector pin-out.) However, a more convenient method is to use an XP-USPG Breakout Panel as shown. The XP-USPG also interfaces the PA jack of the MS-2002 to a standard, 2-pin XLR audio cable. Note: The XP-USPG Breakout Panel can be rack mounted using a BOP-1000 Rack Mount Plate.

TYPICAL 1-CHANNEL CABLE WIRING



Cable Type: 22AWG Stranded, 2-Pair Twisted-wire, with Shield

Connector Type: 3-Pin XLR Audio (Neutrik or Switchcraft)*

Pin 1: Common

Pin 2: Channel Audio / Power

Pin 3: Channel Audio / Power

Shield: Earth ground

Denotes twisted pair.

Denotes shield.

TYPICAL 2-CHANNEL CABLE WIRING

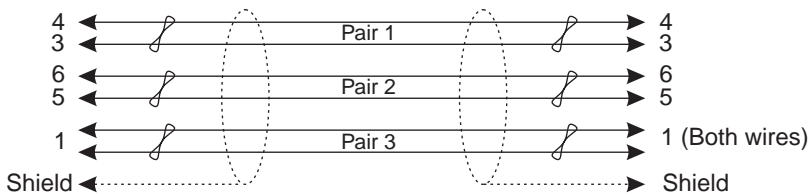

Cable Type: 22AWG Stranded, 3-Pair Twisted-wire, with Shield

Connector Type: 6-Pin XLR Audio (Neutrik only, not compatible with 6-pin Switchcraft)*

Pin 1: Channel 1 & 2 Common

Pin 2: No connection

Pin 3: Channel 1 Audio / Power

Pin 4: Channel 1 Audio / Power

Pin 5: Channel 2 Audio / Power

Pin 6: Channel 2 Audio / Power

Shield: Earth ground

Denotes twisted pair.

Denotes shield.

"Y" CABLE WIRING

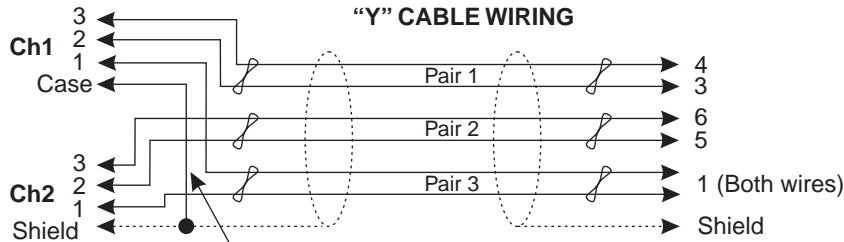

Use second drain wire if available, or add an extra section of wire.

* Standard cables are generally constructed using a male connector at one end and a female connector at the other end. This allows several cables to be interconnected to create longer cable runs. Audiocom master stations, speaker stations and belt packs also typically provide both a male and female Neutrik connector for each intercom channel. This permits loop-through connection of several intercom stations using the standard cables. Audiocom power supplies use a 3-pin male Neutrik connector for each channel. Audiocom wallplates use male Neutrik connectors.

Figure 7 - Audiocom Intercom Cables

Power-Up Check

Plug in the MS-2002. When power is first applied to the MS-2002, it will perform a power-up reset, in which the front panel indicators will cycle through all of their possible colors and then turn off. This verifies the general operation of the intercom station and indicators. The MS-2002 also reads the settings of all DIP switches at this time and configures itself accordingly.

Test Tone

The MS-2002 can generate a test tone, which can be used to verify intercom channel operation after installation or to locate a malfunction. This test tone is also used for the sidetone adjustment which follows. Use the test tone as follows:

1. Simultaneously press the All Talk and PA keys to activate the test tone.
2. Tap the Call key for the channel that you want to test (can be either a MS-2002 channel or an EMS4001 channel).
3. Verify that the test tone can be heard at all intercom stations on the channel. Replace any defective cable or intercom station where the test tone is being lost.
4. Tap the same Call key to stop the test signal on that channel.
5. Press any key except a Call key to turn off the test tone.

Sidetone Adjustment

The MS-2002 uses full-duplex audio (the same as a conventional telephone line) in which the talk and listen audio are sent and received on the same line. Thus, when you talk on a channel, you will also here your own voice back in the speaker or headphones. This is called sidetone. If you are using the MS-2002 with a microphone and speaker, sidetone could cause unwanted feedback, since the microphone may pick up your returned voice audio and re-amplify it. This could also happen if you are using a headset where the ear cushions do not completely cover the ears, although it is probably much less likely. In either of these cases, you should minimize the amount of sidetone. On the other hand, if you are using headphones that completely enclose the ears, a certain amount of your own voice level is desirable to overcome the muffled sensation when talking. See figure 8, page 16, for the adjustment locations.

If you are using a speaker and microphone, or open-ear style headphones, adjust sidetone as follows:

1. Simultaneously press the All Talk and PA keys to activate the test tone.
2. Tap the channel 1 Call key to send the test tone on channel 1.
3. Increase the volume until you can hear the test tone.
4. Using a small flat-bladed screwdriver, adjust the channel 1 sidetone through the access hole in the bottom of the MS-2002 (Figure) to minimize the tone volume.
5. Tap the channel 1 Call key to turn off the test tone on channel 1 when finished.
6. Tap the channel 2 Call key, and repeat the adjustment for the channel 2 sidetone.
7. Tap any other key, except a Call key, to turn off the test tone when finished.

If you are using headphones that completely enclose the ears, adjust sidetone as follows:

1. Tap the Headset key to turn the headset microphone on.
2. Tap the channel 1 Talk key to turn it on.
3. While speaking into the microphone, use a small flat-bladed screwdriver to adjust the channel 1 sidetone so that you hear your voice at an acceptable level in the headphones. Tap the channel 1 Talk key to turn it off when finished.
4. Tap the channel 2 Talk key to turn it on, and adjust the channel 2 sidetone as for channel 1. Tap the channel 2. Talk key to turn it off when finished.

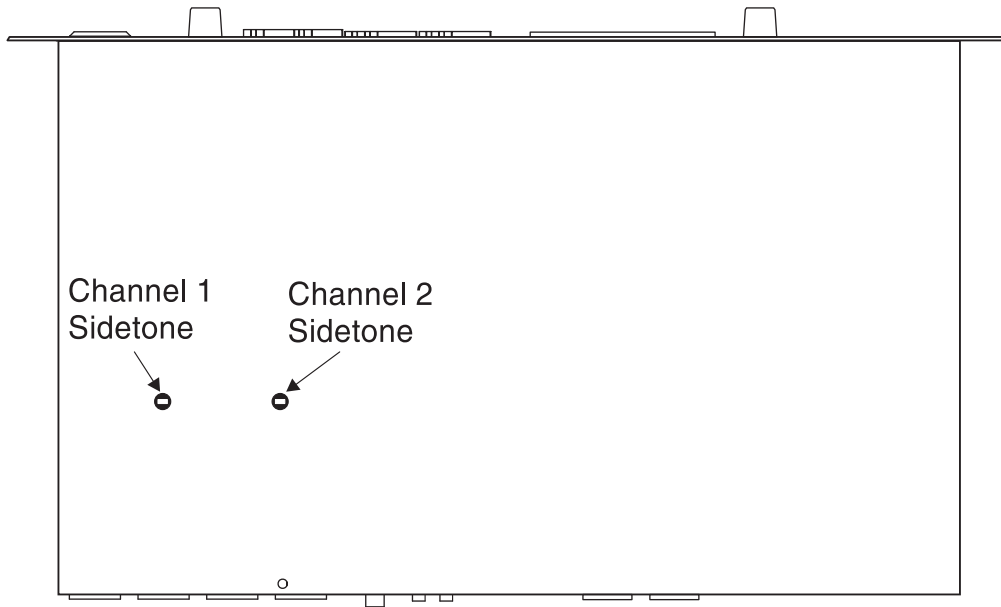

Figure 8 - MS-2002 Bottom View

Voice-Activated Microphone (Vox) Setup

If you are going to use vox, you must adjust the vox level for proper operation. If the vox level is too low, room noise will activate the microphone. If the Vox level is too high, the microphone will not activate when you begin talking.

Check and set the level as follows:

1. If you are using a headset, tap the Headset key twice to turn on headset Vox. Or, if you are using a panel microphone, tap the Panel Mic key twice to turn on panel mic Vox. Whichever key you tap, it will glow orange when the microphone is off and will flicker or turn green when sound is picked up by the microphone.
2. Position the microphone at its normal operating location. If you are using a headset, put the headset on and position the microphone close to your mouth. Insure that background noise is at the normal operating level.
3. Do not speak into the microphone.
4. Check the Headset or Panel Mic key, whichever you are using. If the key is constantly glowing orange, turn the Vox trimmer clockwise until the key begins to flicker green (mic activating) then turn the trimmer slightly back in the counterclockwise direction until the Panel Mic key just returns to steady orange (mic off). If you are wearing a headset, make sure that breathing and movement do not cause the Panel Mic key to flicker green. If they do, adjust the Vox control slightly more in the counterclockwise direction to eliminate this.
5. Speak into the microphone in a normal voice, and check that the headset key immediately turns green when you talk. If it does not, move the microphone closer to your mouth. If you are still unable to get satisfactory results, it may be that the microphone does not have the directional characteristics required for the noise level in the room. A directional, or cardioid, microphone is recommended when using Vox. Omnidirectional microphones mode, the Mic Kill key will be unlit, and in programming mode it will be lit continuously. To return the MS-2002 to normal operation if it has been left in programming mode, tap the Mic Kill key.

Operation

Note: A quick-reference to the following operating features can be found on the inside of the back cover.

NORMAL VS PROGRAMMING MODE

The MS-2002 has two operating modes: normal operating mode and programming mode. In normal operating mode, the Mic Kill key will be unlit, and in programming mode it will be lit continuously. To return the MS-2002 to normal operation if it has been left in programming mode, tap the Mic Kill key.

VOLUME ADJUSTMENT

If you are using a headset, adjust the intercom listen level with the left Volume control on the front panel of the MS-2002. If you are using a speaker, adjust the intercom listen level with the right Volume control next to the speaker. External speakers will require their own volume controls

RECEIVING CALLS

1. When there is an incoming call signal on a channel, the Call key for that channel will flash red. There will also be a beep tone if the beep feature has been activated (page 7).
2. Activate the microphone: If you are using a dynamic-mic headset tap the Headset key to turn the mic on; if you are using a panel-mounted microphone or an electret-mic headset, tap the Panel Mic key to turn the mic on.

Note: You can also use the voice-activated microphone (Vox) feature. See page 16.

3. Turn on the Talk and Listen keys for the calling channel and begin your conversation. Turn the keys off when finished.

Note: When you tap the Headset key, or the Panel Mic key, or any Talk or Listen key, it will lock in the on position. You may then tap the key again to turn it off. For momentary activation, press and hold the key. It will remain on as long as you hold it and it will turn off when you release it.

CALLING AN INTERCOM CHANNEL

1. Press and hold the Call key for the channel that you want to call. An inaudible call signal will be sent, and your listen key for that channel will automatically turn on in preparation to receive a verbal response.
2. When you hear a response, release the Call key.
3. If you are using manual microphone activation instead of Vox, make sure your microphone is on: for a dynamic mic headset, tap the Headset key to turn it on; for a panel-mounted microphone or electret headset, tap the Panel Mic key to turn it on.
4. Turn on the Talk key for the channel you called to begin your conversation.
5. Turn off your Talk and Listen keys to end the conversation.

MICROPHONE MUTE DURING TALK

You can mute the microphone while talking. Simply tap either the Headset key or the Panel Mic key, whichever is currently being used. Tap the key again to turn the microphone back on. (If you are using Vox, tap the key twice to reactivate vox.)

ALL TALK

You can talk to all intercom stations that currently have their listens activated. This applies to both channels of the MS-2002 as well as all talk channels of any connected EMS4001 Expansion Stations. Use All Talk as follows:

1. If you are using manual microphone activation instead of Vox, make sure the proper microphone switch is turned on (either Headset or Panel Mic).
2. Press and hold the All Talk key while talking. Release it when finished.

Note: To insure that the All Talk key is never accidentally left in the on position, it does not latch.

Public Address (PA)

If the PA output on the back panel of the MS-2002 is connected to a public address system, you can talk on the public address system as follows:

1. If you are using manual microphone activation instead of Vox, make sure the proper microphone switch is turned on (either Headset or Panel Mic).
2. Press and hold the PA key while talking. Release it when finished.

Note: To insure that the PA key is never accidentally left in the on position, it does not have latching operation.

Turning the Program Inputs On and Off

1. Insure that program inputs have been connected at the back panel and that the program sources are on.
2. Press and hold the Mic Kill key for about 2 seconds, then release it. It should now be glowing green to indicate that the MS-2002 is in programming mode.
3. The current status of the program inputs is indicated by the Talk keys. If the channel 1 Talk key is lit, the program 1 input is currently activated to channel 1; if channel 2 talk is lit, program 2 is activated to channel 2. Tap either Talk key to turn the program input for that channel on or off.
4. When the program inputs are configured as desired, tap the Mic Kill key to exit programming mode and return to normal operation.
5. Adjust program 1 and 2 levels via the trimmers on the back panel of the MS-2002.

Using Mic Kill

If the Mic Kill feature has been enabled you can use it to deactivate all talk keys on a single channel or on all channels. This feature is useful when a remote talk key has been left on and is causing unwanted noise on a channel.

Use Mic Kill as follows:

1. Tap the Mic Kill key. It will blink green.
2. Tap the Talk or Listen key for a channel to turn off all talk keys on that channel. Or, tap the All Talk key to turn off all talk keys. The key you tap will turn green and the Mic Kill signal will be sent.
3. Tap Mic Kill to exit.

Using Voice-Activated Microphone (Vox)

If you use Vox you will not have to insure that the microphone key is turned on whenever you want to talk. Activate

Vox as follows:

1. Make sure the Headset and Panel Mic keys are off.
2. If you are using a headset, tap the Headset key twice to turn on headset vox. Or, if you are using a panel microphone, tap the Panel Mic key twice to turn on panel mic vox. Whichever key you tap, it will glow orange when the microphone is off and will flicker or turn green when the microphone turns on.

Note: The Vox level may require adjustment, see "Voice-Activated Microphone (Vox) Setup", page 16.

Incoming Call Beep On/Off

Normally, incoming calls are indicated by red-flashing Call keys. An optional beep tone can also be enabled as follows:

1. Ensure that this feature has been activated via internal switches (page 7).
2. Press and hold the Mic Kill key for about 2 seconds, then release it. It should now be glowing green to indicate that the intercom station is in programming mode.
3. Tap either Call key on the MS-2002 to turn the beep feature on or off. (It doesn't matter which one you tap, since this feature affects both channels.)
4. Tap the Mic Kill key to return to normal operation.

Specifications

General

Power Requirements:

AC Input: 100-240 VAC, 50/60 Hz

Channel Power: 24 VDC nominal (12 to 30 VDC), 65 to 150 mA

MS2002 is capable of supplying 2 amps overall

Dimensions: 1.75" (44.5 mm) high x 19" (483 mm) wide x 10.31" (261.9 mm) deep

Weight: approximately 4.5lb (2 kg)

Environmental Requirements:

Storage: -20°C to 80°C; 0% to 95% humidity, non-condensing

Operating: -15°C to 60°C; 0% to 95% humidity, non-condensing

Dynamic-mic Headset

Microphone: 50 to 200 ohm, dynamic (balanced or unbalanced)

Headphones: 150 to 600 ohm, monaural

Connector Type: XLR-4M

Pin 1 Microphone low

Pin 2 Microphone high

Pin 3 Headphone high

Pin 4 Headphone low

Panel Microphone Input

Microphone Type: Electret condenser

Power: Phantom (+5 VDC)

Nominal Level: -42 dBu

Maximum Level: -25 dBu

Connector Type: IKP12 (MCP-90 series, stereo plug connector)

Program Input

Input Level: 100mV maximum

Voltage Gain: 25 ±3 dB

Output Level (to intercom channel) : 1.0 Vrms nominal, 2.3 Vrms max.

Input Impedance: 75 kohm

Common Mode Rejection: Greater than 50 dB

Connector Type: 9-pin female D-sub (DE9S)

Pin 1 Ground

Pin 2 Program 1 input low

Pin 3 Program 2 input low

Pin 4 NC

Pin 5 NC

Pin 6 Program 1 input high

Pin 7 Program 2 input high

Pin 8 NC

Pin 9 NC

Intercom Channels, Balanced Mode (Both Back Panel and internal switches (BAL/UNBAL) must be set to same setting)

Output Level: 1 Vrms nominal

Input Impedance: 300 ohms

Bridging Impedance: greater than 10,000 ohms

Sidetone: -40 dB, 35 dB adjustable range

Call Signaling:

Send: 20 kHz \pm 100 Hz, 0.5 Vrms \pm 10%

Receive: 20 kHz \pm 800 Hz, 100 mVrms

Mic-Kill Frequency:

Send: 24 kHz \pm 300 Hz, 0.5 Vrms \pm 10%

Detect: 24 kHz \pm 800 Hz, 100 mVrms

Noise Contribution: less than -70 dB

Common Mode Rejection Ratio: greater than 50 dB

Connector Type: One XLR-3M and XLR-3F pair, wired in parallel, for each channel (permits "loop-thru" connection). Two XLR-6M (Neutrik) connectors for 2-channel connection.

XLR-3 Balanced Configuration Pinouts

Pin 1: Common

Pin 2: Intercom audio low and +24 VDC input

Pin 3: Intercom audio high and +24 VDC input

XLR-6 Balanced Configuration Pinouts

Pin 1: Audio and DC Common

Pin 2: Local power (12 to 15 VDC, 65 to 150 mA)

Pin 3: Intercom channel 1 audio low and +24 VDC phantom power

Pin 4: Intercom channel 1 audio high and +24 VDC phantom power

Pin 5: Intercom channel 2 audio low and +24 VDC phantom power

Pin 6: Intercom channel 2 audio high and +24 VDC phantom power

Intercom Channel, Unbalanced Mode (Both Back Panel and internal switches (BAL/UNBAL) have to be set to same setting)

Output Level: 1 Vrms \pm 10%

Input Impedance: 150 ohms

Bridging Impedance: greater than 10,000 ohms

Call Signaling:

Send: 11 \pm 3 VDC

Receive: 4 VDC minimum

Connector Type: Uses same connectors as for balanced mode, above, but with pinouts modified by BAL/UNBAL switch on back panel as follows:

XLR-3 Unbalanced Configuration Pinouts

Pin 1: Common

Pin 2: +24 VDC input

Pin 3: Intercom audio high

XLR-6 Unbalanced Configuration Pinouts

Pin 1: Common

Pin 2: Local power (12 to 15 VDC, 65 to 150 mA)

Pin 3: Channel 1 +24 VDC input

Pin 4: Channel 1 Intercom audio high and DC call

Pin 5: Channel 2 +24 VDC input

Pin 6: Channel 2 Intercom audio high and DC call

PA Output

Output Level: 235 mVrms nominal

Connector Type: 1/8-inch Stereo Phone Jack

Tip: PA output high

Ring: Not used

Sleeve: Common

Speaker Output

Output Level: 0 dB nominal (1.0 Vrms)

Output Impedance: 1000 ohms nominal

Frequency Response: 200 Hz to 8 kHz +1/-3dB

Connector Type: RCA Phono Jack

Tip: Speaker output high

Sleeve: Common

Expansion Input /Output

Type: 2.0 mm stereo phone jack

Tip: Talk output

Ring: Listen input

Sleeve: Common

Headphone Amplifier

Voltage Gain: 30 \pm 3 dB

Maximum Output: 250 mW \pm 10% into 150 ohms, 65 mW \pm 10% into 600 ohms

Frequency Response: 200 Hz to 8 kHz +1/-3db

Incoming Call Beep Tone: 2 kHz, at the headphones

Total Harmonic Distortion: Less than 0.2% at 200 mW

Sidetone: 18 \pm 2 dB, adjustable

Quick Reference

DESCRIPTION	ACTION
Reset MS-2002	Press All Talk and Listen 1
Reset EMS4001	Press All Talk and Listen 5
Test signal on	Press All Talk and PA, then tap Call
Test signal off	Tap Call, then tap any other key
Mic latched on	Tap Headset or Panel Mic (key is green)
Mic latched off	Tap Headset or Panel Mic
Mic momentary on	Hold Headset or Panel Mic
Mic momentary off	Release Headset or Panel Mic
VOX mode on	Tap twice: Headset or Panel Mic (key is orange)
VOX mode off	Tap Headset or Panel Mic
All talk on	Hold All Talk when Headset or Panel Mic is lit (All Talk key is green)
All talk off	Release All Talk
Public Address	Hold PA when Headset or Panel Mic is lit (PA key is green)
Mic kill, one channel	Tap Mic Kill, then tap Talk or Listen (Mic Kill key will blink green and the Talk and Listen keys are green). Tap Mic Kill to exit
Mic kill, all channels	Tap Mic Kill, then tap All Talk (Mic Kill key will blink green and all Talk and Listen keys are green). Tap Mic Kill to exit
Program on	Hold Mic Kill, then tap channel's Talk key (key is green). Tap Mic Kill to exit
Program off	Hold Mic Kill, then tap the channel's Talk key. Tap Mic Kill to exit
Audible call alert on	Hold Mic Kill, then tap either Call (all Call keys are red). Tap Mic Kill to exit
Audible call alert off	Hold Mic Kill, then tap either Call. Tap Mic Kill to exit
Turn mic kill key off	Tap Mic Kill
Talk latched on	Tap Talk (key is green)
Talk latched off	Tap Talk
Talk momentary on	Hold Talk
Talk momentary off	Release Talk
Call signal on	Hold Call
Call signal off	Release Call
Receive call signal	(Call key blinks red)
Listen latched on	Tap Listen (key is green)
Listen latched off	Tap Listen
Listen momentary on	Hold Listen



TELEX COMMUNICATIONS, INC. • 12000 Portland Avenue South, Burnsville, MN 55337 USA

Free Manuals Download Website

<http://myh66.com>

<http://usermanuals.us>

<http://www.somanuals.com>

<http://www.4manuals.cc>

<http://www.manual-lib.com>

<http://www.404manual.com>

<http://www.luxmanual.com>

<http://aubethermostatmanual.com>

Golf course search by state

<http://golfingnear.com>

Email search by domain

<http://emailbydomain.com>

Auto manuals search

<http://auto.somanuals.com>

TV manuals search

<http://tv.somanuals.com>