

TMS320C2xx User's Guide

Literature Number: SPRU127B
Manufacturing Part Number: D412008-9761 revision A
January 1997



Printed on Recycled Paper

IMPORTANT NOTICE

Texas Instruments (TI) reserves the right to make changes to its products or to discontinue any semiconductor product or service without notice, and advises its customers to obtain the latest version of relevant information to verify, before placing orders, that the information being relied on is current.

TI warrants performance of its semiconductor products and related software to the specifications applicable at the time of sale in accordance with TI's standard warranty. Testing and other quality control techniques are utilized to the extent TI deems necessary to support this warranty. Specific testing of all parameters of each device is not necessarily performed, except those mandated by government requirements.

Certain applications using semiconductor products may involve potential risks of death, personal injury, or severe property or environmental damage ("Critical Applications").

TI SEMICONDUCTOR PRODUCTS ARE NOT DESIGNED, INTENDED, AUTHORIZED, OR WARRANTED TO BE SUITABLE FOR USE IN LIFE-SUPPORT APPLICATIONS, DEVICES OR SYSTEMS OR OTHER CRITICAL APPLICATIONS.

Inclusion of TI products in such applications is understood to be fully at the risk of the customer. Use of TI products in such applications requires the written approval of an appropriate TI officer. Questions concerning potential risk applications should be directed to TI through a local SC sales office.

In order to minimize risks associated with the customer's applications, adequate design and operating safeguards should be provided by the customer to minimize inherent or procedural hazards.

TI assumes no liability for applications assistance, customer product design, software performance, or infringement of patents or services described herein. Nor does TI warrant or represent that any license, either express or implied, is granted under any patent right, copyright, mask work right, or other intellectual property right of TI covering or relating to any combination, machine, or process in which such semiconductor products or services might be or are used.

Copyright © 1996, Texas Instruments Incorporated

Read This First

About This Manual

This user's guide describes the architecture, hardware, assembly language instructions, and general operation of the TMS320C2xx digital signal processors (DSPs). This manual can also be used as a reference guide for developing hardware and/or software applications. In this document, 'C2xx refers to any of the TMS320C2xx devices, except where device-specific information is explicitly stated. When device-specific information is given, the device name may be abbreviated; for example, TMS320C203 will be abbreviated as 'C203.

How to Use This Manual

Chapter 1, *Introduction*, summarizes the TMS320 family of products and then introduces the key features of the TMS320C2xx generation of that family. Chapter 2, *Architectural Overview*, summarizes the 'C2xx architecture, providing information about the CPU, bus structure, memory, on-chip peripherals, and scanning logic.

If you are reading this manual to learn about the 'C209, Chapter 11 is important for you. There are some notable differences between the 'C209 and other 'C2xx devices, and Chapter 11 explains these differences. In addition, it shows how to use this manual to get a complete picture of the 'C209.

The following table points you to major topics.

For this information:	Look here:
Addressing modes (for addressing data memory)	Chapter 6, <i>Addressing Modes</i>
Assembly language instructions	Chapter 7, <i>Assembly Language Instructions</i>
Assembly language instructions of TMS320C1x, 'C2x, 'C2xx, and 'C5x compared	Appendix B, <i>TMS320C1x/C2x/C2xx/C5x Instruction Set Comparison</i>
Boot loader	Chapter 4, <i>Memory and I/O Spaces</i>
Clock generator	Chapter 8, <i>On-Chip Peripherals</i>
CPU	Chapter 3, <i>Central Processing Unit</i>
Custom ROM from TI	Appendix D, <i>Submitting ROM Codes to TI</i>
Emulator	Appendix E, <i>Design Considerations for Using XDS510 Emulator</i>
Features	Chapter 1, <i>Introduction</i> Chapter 2, <i>Architectural Overview</i>
Input/output ports	Chapter 4, <i>Memory and I/O Spaces</i>
Interrupts	Chapter 5, <i>Program Control</i>
Memory configuration	Chapter 4, <i>Memory and I/O Spaces</i>
Memory interfacing	Chapter 4, <i>Memory and I/O Spaces</i>
On-chip peripherals	Chapter 8, <i>On-Chip Peripherals</i>
Pipeline	Chapter 5, <i>Program Control</i>
Program control	Chapter 5, <i>Program Control</i>
Program examples	Appendix C, <i>Program Examples</i>
Program-memory address generation	Chapter 5, <i>Program Control</i>
Registers summarized	Appendix A, <i>Register Summary</i>
Serial ports	Chapter 9, <i>Synchronous Serial Port</i> Chapter 10, <i>Asynchronous Serial Port</i>
Stack	Chapter 5, <i>Program Control</i>
Status registers	Chapter 5, <i>Program Control</i>
Timer	Chapter 8, <i>On-Chip Peripherals</i>
TMS320C209 differences and similarities	Chapter 11, <i>TMS320C209</i>
Wait-state generator	Chapter 8, <i>On-Chip Peripherals</i>

Notational Conventions

This document uses the following conventions:

- Program listings and program examples are shown in a special typeface.

Here is a segment of a program listing:

```
OUTPUT LDP      #6          ;select data page 6
        BLDD    #300, 20h   ;move data at address 300h to 320h
        RET
```

- In syntax descriptions, **bold** portions of a syntax should be entered as shown; *italic* portions of a syntax identify information that you specify. Here is an example of an instruction syntax:

BLDD *source, destination*

BLDD is the instruction mnemonic, which must be typed as shown. You specify the two parameters, *source* and *destination*.

- Square brackets ([and]) identify an optional parameter. If you use an optional parameter, you specify the information within the brackets; you do not type the brackets themselves. You separate each optional operand from required operands with a comma and a space. Here is a sample syntax:

BLDD *source, destination* [, **AR***n*]

BLDD is the instruction. The two required operands are *source* and *destination*, and the optional operand is **AR***n*. **AR** is bold and *n* is italic; if you choose to use **AR***n*, you must type the letters A and R and then supply a chosen value for *n* (in this case, a value from 0 to 7). Here is an example:

```
BLDD *, #310h, AR3
```

Information About Cautions

This book contains cautions.

This is an example of a caution statement.

A caution statement describes a situation that could potentially damage your software or equipment.

The information in a caution is provided for your protection. Please read each caution carefully.

Related Documentation From Texas Instruments

This subsection describes related TI™ documents that can be ordered by calling the Texas Instruments Literature Response Center at (800) 477–8924. When ordering, please identify the document by its title and literature number.

The following data sheets contain the electrical and timing specifications for the TMS320C2xx devices, as well as signal descriptions and pinouts for all of the available packages:

- TMS320C2xx data sheet (literature number SPRS025)
- TMS320F2xx data sheet (literature number SPRS050). This data sheet covers the TMS320C2xx devices that have on-chip flash memory.

The books listed below provide additional information about using the TMS320C2xx devices and related support tools, as well as more general information about using the TMS320 family of DSPs.

TMS320C1x/C2x/C2xx/C5x Code Generation Tools Getting Started Guide (literature number SPRU121) describes how to install the TMS320C1x, TMS320C2x, TMS320C2xx, and TMS320C5x assembly language tools and the C compiler for the 'C1x, 'C2x, 'C2xx, and 'C5x devices. The installation for MS-DOS™, OS/2™, SunOS™, and Solaris™ systems is covered.

TMS320C1x/C2x/C2xx/C5x Assembly Language Tools User's Guide (literature number SPRU018) describes the assembly language tools (assembler, linker, and other tools used to develop assembly language code), assembler directives, macros, common object file format, and symbolic debugging directives for the 'C1x, 'C2x, 'C2xx, and 'C5x generations of devices.

TMS320C2x/C2xx/C5x Optimizing C Compiler User's Guide (literature number SPRU024) describes the 'C2x/C2xx/C5x C compiler. This C compiler accepts ANSI standard C source code and produces TMS320 assembly language source code for the 'C2x, 'C2xx, and 'C5x generations of devices.

TMS320C2xx C Source Debugger User's Guide (literature number SPRU151) tells you how to invoke the 'C2xx emulator and simulator versions of the C source debugger interface. This book discusses various aspects of the debugger interface, including window management, command entry, code execution, data management, and breakpoints. It also includes a tutorial that introduces basic debugger functionality.

TMS320C2xx Simulator Getting Started (literature number SPRU137) describes how to install the TMS320C2xx simulator and the C source debugger for the 'C2xx. The installation for MS-DOS™, PC-DOS™, SunOS™, Solaris™, and HP-UX™ systems is covered.

TMS320C2xx Emulator Getting Started Guide (literature number SPRU209) tells you how to install the Windows™ 3.1 and Windows™ 95 versions of the 'C2xx emulator and C source debugger interface.

XDS51x Emulator Installation Guide (literature number SPNU070) describes the installation of the XDS510™, XDS510PP™, and XDS510WS™ emulator controllers. The installation of the XDS511™ emulator is also described.

JTAG/MPSD Emulation Technical Reference (literature number SPDU079) provides the design requirements of the XDS510™ emulator controller. Discusses JTAG designs (based on the IEEE 1149.1 standard) and modular port scan device (MPSD) designs.

TMS320 DSP Development Support Reference Guide (literature number SPRU011) describes the TMS320 family of digital signal processors and the tools that support these devices. Included are code-generation tools (compilers, assemblers, linkers, etc.) and system integration and debug tools (simulators, emulators, evaluation modules, etc.). Also covered are available documentation, seminars, the university program, and factory repair and exchange.

Digital Signal Processing Applications with the TMS320 Family, Volumes 1, 2, and 3 (literature numbers SPRA012, SPRA016, SPRA017) Volumes 1 and 2 cover applications using the 'C10 and 'C20 families of fixed-point processors. Volume 3 documents applications using both fixed-point processors as well as the 'C30 floating-point processor.

TMS320 DSP Designer's Notebook: Volume 1 (literature number SPRT125). Presents solutions to common design problems using 'C2x, 'C3x, 'C4x, 'C5x, and other TI DSPs.

TMS320 Third-Party Support Reference Guide (literature number SPRU052) alphabetically lists over 100 third parties that provide various products that serve the family of '320 digital signal processors. A myriad of products and applications are offered—software and hardware development tools, speech recognition, image processing, noise cancellation, modems, etc.

Related Articles

“A Greener World Through DSP Controllers”, Panos Papamichalis, *DSP & Multimedia Technology*, September 1994.

“A Single-Chip Multiprocessor DSP for Image Processing—TMS320C80”, Dr. Ing. Dung Tu, *Industrie Elektronik*, Germany, March 1995.

“Application Guide with DSP Leading-Edge Technology”, Y. Nishikori, M. Hattori, T. Fukuhara, R. Tanaka, M. Shimoda, I. Kudo, A. Yanagitani, H. Miyaguchi, et al., *Electronics Engineering*, November 1995.

“Approaching the No-Power Barrier”, Jon Bradley and Gene Frantz, *Electronic Design*, January 9, 1995.

“Beware of BAT: DSPs Add Brilliance to New Weapons Systems”, Panos Papamichalis, *DSP & Multimedia Technology*, October 1994.

“Choose DSPs for PC Signal Processing”, Panos Papamichalis, *DSP & Multimedia Technology*, January/February 1995.

“Developing Nations Take Shine to Wireless”, Russell MacDonald, Kara Schmidt and Kim Higden, *EE Times*, October 2, 1995.

“Digital Signal Processing Solutions Target Vertical Application Markets”, Ron Wages, *ECN*, September 1995.

“Digital Signal Processors Boost Drive Performance”, Tim Adcock, *Data Storage*, September/October 1995.

“DSP and Speech Recognition, An Origin of the Species”, Panos Papamichalis, *DSP & Multimedia Technology*, July 1994.

“DSP Design Takes Top-Down Approach”, Andy Fritsch and Kim Asal, *DSP Series Part III*, *EE Times*, July 17, 1995.

“DSPs Advance Low-Cost ‘Green’ Control”, Gregg Bennett, *DSP Series Part II*, *EE Times*, April 17, 1995.

“DSPs Do Best on Multimedia Applications”, Doug Rasor, *Asian Computer World*, October 9–16, 1995.

“DSPs: Speech Recognition Technology Enablers”, Gene Frantz and Gregg Bennett, *I&CS*, May 1995.

“Easing JTAG Testing of Parallel-Processor Projects”, Tony Coomes, Andy Fritsch, and Reid Tatge, *Asian Electronics Engineer*, Manila, Philippines, November 1995.

“Fixed or Floating? A Pointed Question in DSPs”, Jim Larimer and Daniel Chen, *EDN*, August 3, 1995.

“Function-Focused Chipsets: Up the DSP Integration Core”, Panos Papamichalis, *DSP & Multimedia Technology*, March/April 1995.

“GSM: Standard, Strategien und Systemchips”, Edgar Auslander, *Elektronik Praxis*, Germany, October 6, 1995.

“High Tech Copiers to Improve Images and Reduce Paperwork”, Karl Gutttag, *Document Management*, July/August 1995.

“Host-Enabled Multimedia: Brought to You by DSP Solutions”, Panos Papamichalis, *DSP & Multimedia Technology*, September/October 1995.

“Integration Shrinks Digital Cellular Telephone Designs”, Fred Cohen and Mike McMahan, *Wireless System Design*, November 1994.

“On-Chip Multiprocessing Melds DSPs”, Karl Gutttag and Doug Deao, *DSP Series Part III*, *EE Times*, July 18, 1994.

“Real-Time Control”, Gregg Bennett, *Appliance Manufacturer*, May 1995.

“Speech Recognition”, P.K. Rajasekaran and Mike McMahan, *Wireless Design & Development*, May 1995.

“Telecom Future Driven by Reduced Milliwatts per DSP Function”, Panos Papamichalis, *DSP & Multimedia Technology*, May/June 1995.

“The Digital Signal Processor Development Environment”, Greg Peake, *Embedded System Engineering*, United Kingdom, February 1995.

“The Growing Spectrum of Custom DSPs”, Gene Frantz and Kun Lin, *DSP Series Part II*, *EE Times*, April 18, 1994.

“The Wide World of DSPs,” Jim Larimer, *Design News*, June 27, 1994.

“Third-Party Support Drives DSP Development for Uninitiated and Experts Alike”, Panos Papamichalis, *DSP & Multimedia Technology*, December 1994/January 1995.

“Toward an Era of Economical DSPs”, John Cooper, *DSP Series Part I*, *EE Times*, Jan. 23, 1995.

Trademarks

TI, 320 Hotline On-line, XDS510, XDS510PP, XDS510WS, and XDS511 are trademarks of Texas Instruments Incorporated.

HP-UX is a trademark of Hewlett-Packard Company.

Intel is a trademark of Intel Corporation.

MS-DOS and Windows are registered trademarks of Microsoft Corporation.

PAL[®] is a registered trademark of Advanced Micro Devices, Inc.

OS/2, PC, and PC-DOS are trademarks of International Business Machines Corporation.

Solaris and SunOS are trademarks of Sun Microsystems, Inc.

Contents

1	Introduction	1-1
	<i>Summarizes the features of the TMS320 family of products and presents typical applications. Describes the TMS320C2xx DSP and lists its key features.</i>	
1.1	TMS320 Family	1-2
1.1.1	History, Development, and Advantages of TMS320 DSPs	1-2
1.1.2	Typical Applications for the TMS320 Family	1-4
1.2	TMS320C2xx Generation	1-5
1.3	Key Features of the TMS320C2xx	1-6
2	Architectural Overview	2-1
	<i>Summarizes the TMS320C2xx architecture. Provides information about the CPU, bus structure, memory, on-chip peripherals, and scanning logic.</i>	
2.1	'C2xx Bus Structure	2-3
2.2	Central Processing Unit	2-5
2.2.1	Central Arithmetic Logic Unit (CALU) and Accumulator	2-5
2.2.2	Scaling Shifters	2-5
2.2.3	Multiplier	2-6
2.2.4	Auxiliary Register Arithmetic Unit (ARAU) and Auxiliary Registers	2-6
2.3	Memory and I/O Spaces	2-7
2.3.1	Dual-Access On-Chip RAM	2-7
2.3.2	Single-Access On-Chip Program/Data RAM	2-8
2.3.3	Factory-Masked On-Chip ROM	2-8
2.3.4	Flash Memory	2-9
2.4	Program Control	2-10
2.5	On-Chip Peripherals	2-11
2.5.1	Clock Generator	2-11
2.5.2	CLKOUT1-Pin Control (CLK) Register	2-11
2.5.3	Hardware Timer	2-11
2.5.4	Software-Programmable Wait-State Generator	2-11
2.5.5	General-Purpose I/O Pins	2-12
2.5.6	Serial Ports	2-12
2.6	Scanning-Logic Circuitry	2-13

3	Central Processing Unit	3-1
	<i>Describes the TMS320C2xx CPU. Includes information about the central arithmetic logic unit, the accumulator, the shifters, the multiplier, and the auxiliary register arithmetic unit. Concludes with a description of the status register bits.</i>	
3.1	Input Scaling Section	3-3
3.2	Multiplication Section	3-5
3.2.1	Multiplier	3-5
3.2.2	Product-Scaling Shifter	3-6
3.3	Central Arithmetic Logic Section	3-8
3.3.1	Central Arithmetic Logic Unit (CALU)	3-9
3.3.2	Accumulator	3-9
3.3.3	Output Data-Scaling Shifter	3-11
3.4	Auxiliary Register Arithmetic Unit (ARAU)	3-12
3.4.1	ARAU and Auxiliary Register Functions	3-13
3.5	Status Registers ST0 and ST1	3-15
4	Memory and I/O Spaces	4-1
	<i>Describes the configuration and use of the TMS320C2xx memory and I/O spaces. Includes memory/address maps and descriptions of the HOLD (direct memory access) operation and the on-chip boot loader.</i>	
4.1	Overview of the Memory and I/O Spaces	4-2
4.1.1	Pins for Interfacing to External Memory and I/O Spaces	4-3
4.2	Program Memory	4-5
4.2.1	Interfacing With External Program Memory	4-5
4.3	Local Data Memory	4-7
4.3.1	Data Page 0 Address Map	4-8
4.3.2	Interfacing With External Local Data Memory	4-9
4.4	Global Data Memory	4-11
4.4.1	Interfacing With External Global Data Memory	4-12
4.5	Boot Loader	4-14
4.5.1	Choosing an EPROM	4-14
4.5.2	Connecting the EPROM to the Processor	4-15
4.5.3	Programming the EPROM	4-16
4.5.4	Enabling the Boot Loader	4-17
4.5.5	Boot Loader Execution	4-18
4.5.6	Boot Loader Program	4-21
4.6	I/O Space	4-23
4.6.1	Accessing I/O Space	4-25
4.7	Direct Memory Access Using the HOLD Operation	4-27
4.7.1	$\overline{\text{HOLD}}$ During Reset	4-29
4.8	Device-Specific Information	4-31
4.8.1	TMS320C203 Address Maps and Memory Configuration	4-31
4.8.2	TMS320C204 Address Maps and Memory Configuration	4-34

5	Program Control	5-1
	<i>Describes the TMS320C2xx hardware and software features used in controlling program flow, including program-address generation logic and interrupts. Also describes the reset operation and power-down mode.</i>	
5.1	Program-Address Generation	5-2
5.1.1	Program Counter (PC)	5-3
5.1.2	Stack	5-4
5.1.3	Micro Stack (MSTACK)	5-6
5.2	Pipeline Operation	5-7
5.3	Branches, Calls, and Returns	5-8
5.3.1	Unconditional Branches	5-8
5.3.2	Unconditional Calls	5-8
5.3.3	Unconditional Returns	5-9
5.4	Conditional Branches, Calls, and Returns	5-10
5.4.1	Using Multiple Conditions	5-10
5.4.2	Stabilization of Conditions	5-11
5.4.3	Conditional Branches	5-11
5.4.4	Conditional Calls	5-12
5.4.5	Conditional Returns	5-12
5.5	Repeating a Single Instruction	5-14
5.6	Interrupts	5-15
5.6.1	Interrupt Operation: Three Phases	5-15
5.6.2	Interrupt Table	5-16
5.6.3	Maskable Interrupts	5-18
5.6.4	Interrupt Flag Register (IFR)	5-20
5.6.5	Interrupt Mask Register (IMR)	5-22
5.6.6	Interrupt Control Register (ICR)	5-24
5.6.7	Nonmaskable Interrupts	5-27
5.6.8	Interrupt Service Routines (ISRs)	5-29
5.6.9	Interrupt Latency	5-30
5.7	Reset Operation	5-33
5.8	Power-Down Mode	5-36
5.8.1	Normal Termination of Power-Down Mode	5-36
5.8.2	Termination of Power-Down During a HOLD Operation	5-37
6	Addressing Modes	6-1
	<i>Describes the operation and use of the TMS320C2xx data-memory addressing modes.</i>	
6.1	Immediate Addressing Mode	6-2
6.1.1	Examples of Immediate Addressing	6-2
6.2	Direct Addressing Mode	6-4
6.2.1	Using Direct Addressing Mode	6-6
6.2.2	Examples of Direct Addressing	6-6

6.3	Indirect Addressing Mode	6-9
6.3.1	Current Auxiliary Register	6-9
6.3.2	Indirect Addressing Options	6-9
6.3.3	Next Auxiliary Register	6-11
6.3.4	Indirect Addressing Opcode Format	6-12
6.3.5	Examples of Indirect Addressing	6-15
6.3.6	Modifying Auxiliary Register Content	6-17
7	Assembly Language Instructions	7-1
	<i>Describes the TMS320C2xx assembly language instructions in alphabetical order. Begins with a summary of the TMS320C2xx instructions.</i>	
7.1	Instruction Set Summary	7-2
7.2	How To Use the Instruction Descriptions	7-12
7.2.1	Syntax	7-12
7.2.2	Operands	7-14
7.2.3	Opcode	7-14
7.2.4	Execution	7-15
7.2.5	Status Bits	7-15
7.2.6	Description	7-15
7.2.7	Words	7-16
7.2.8	Cycles	7-16
7.2.9	Examples	7-18
7.3	Instruction Descriptions	7-20
8	On-Chip Peripherals	8-1
	<i>Introduces the TMS320C2xx on-chip peripherals. Describes the clock generator, the CLKOUT1-pin control register, the timer, the wait-state generator, and the general-purpose I/O pins.</i>	
8.1	Control of On-Chip Peripherals	8-2
8.2	Clock Generator	8-4
8.2.1	Clock Generator Options	8-5
8.3	CLKOUT1-Pin Control (CLK) Register	8-7
8.4	Timer	8-8
8.4.1	Timer Operation	8-9
8.4.2	Timer Control Register (TCR)	8-10
8.4.3	Timer Counter Register (TIM) and Timer Period Register (PRD)	8-12
8.4.4	Setting the Timer Interrupt Rate	8-13
8.4.5	The Timer at Hardware Reset	8-13
8.5	Wait-State Generator	8-14
8.5.1	Generating Wait States With the READY Signal	8-14
8.5.2	Generating Wait States With the 'C2xx Wait-State Generator	8-14
8.6	General-Purpose I/O Pins	8-17
8.6.1	Input Pin BIO	8-17
8.6.2	Output Pin XF	8-18
8.6.3	Input/Output Pins IO0, IO1, IO2, and IO3	8-18

9	Synchronous Serial Port	9-1
	<i>Describes the operation and control of the TMS320C2xx on-chip synchronous serial port.</i>	
9.1	Overview of the Synchronous Serial Port	9-2
9.2	Components and Basic Operation	9-3
9.2.1	Signals	9-3
9.2.2	FIFO Buffers and Registers	9-5
9.2.3	Interrupts	9-6
9.2.4	Basic Operation	9-6
9.3	Controlling and Resetting the Port	9-8
9.3.1	Selecting a Mode of Operation (Bit 1 of the SSPCR)	9-12
9.3.2	Selecting Transmit Clock Source and Transmit Frame Sync Source (Bits 2 and 3 of the SSPCR)	9-12
9.3.3	Resetting the Synchronous Serial Port (Bits 4 and 5 of the SSPCR)	9-13
9.3.4	Using Transmit and Receive Interrupts (Bits 8–11 of the SSPCR)	9-13
9.4	Managing the Contents of the FIFO Buffers	9-15
9.5	Transmitter Operation	9-16
9.5.1	Burst Mode Transmission With Internal Frame Sync (FSM = 1, TXM = 1)	9-16
9.5.2	Burst Mode Transmission With External Frame Sync (FSM = 1, TXM = 0)	9-18
9.5.3	Continuous Mode Transmission With Internal Frame Sync (FSM = 0, TXM = 1)	9-20
9.5.4	Continuous Mode Transmission with External Frame Sync (FSM=0, TXM=0)	9-22
9.6	Receiver Operation	9-24
9.6.1	Burst Mode Reception	9-24
9.6.2	Continuous Mode Reception	9-25
9.7	Troubleshooting	9-27
9.7.1	Test Bits	9-27
9.7.2	Burst Mode Error Conditions	9-29
9.7.3	Continuous Mode Error Conditions	9-29
10	Asynchronous Serial Port	10-1
	<i>Describes the operation and control of the TMS320C2xx on-chip asynchronous serial port.</i>	
10.1	Overview of the Asynchronous Serial Port	10-2
10.2	Components and Basic Operation	10-3
10.2.1	Signals	10-3
10.2.2	Baud-Rate Generator	10-4
10.2.3	Registers	10-4
10.2.4	Interrupts	10-5
10.2.5	Basic Operation	10-6

10.3	Controlling and Resetting the Port	10-7
10.3.1	Asynchronous Serial Port Control Register (ASPCR)	10-7
10.3.2	I/O Status Register (IOSR)	10-10
10.3.3	Baud-Rate Divisor Register (BRD)	10-13
10.3.4	Using Automatic Baud-Rate Detection	10-14
10.3.5	Using I/O Pins IO3, IO2, IO1, and IO0	10-15
10.3.6	Using Interrupts	10-17
10.4	Transmitter Operation	10-19
10.5	Receiver Operation	10-20
11	TMS320C209	11-1
	<i>Describes how the TMS320C209 differs from other TMS320C2xx devices and is a central resource for all the TMS320C209-specific control registers and configuration information.</i>	
11.1	'C209 Versus Other 'C2xx Devices	11-2
11.1.1	What Is the Same	11-2
11.1.2	What Is Different	11-2
11.1.3	Where to Find the Information You Need About the TMS320C209	11-3
11.2	'C209 Memory and I/O Spaces	11-5
11.3	'C209 Interrupts	11-10
11.3.1	'C209 Interrupt Registers	11-11
11.3.2	$\overline{\text{IACK}}$ Pin	11-13
11.4	'C209 On-Chip Peripherals	11-14
11.4.1	'C209 Clock Generator Options	11-14
11.4.2	'C209 Timer Control Register (TCR)	11-15
11.4.3	'C209 Wait-State Generator	11-16
A	Register Summary	A-1
	<i>Is a concise, central resource for information about the TMS320C2xx on-chip registers. Includes addresses, reset values, and descriptive illustrations for the registers.</i>	
A.1	Addresses and Reset Values	A-2
A.2	Register Descriptions	A-4
B	TMS320C1x/C2x/C2xx/C5x Instruction Set Comparison	B-1
	<i>Discusses the compatibility of program code among the following devices: TMS320C1x, TMS320C2x, TMS320C2xx, and TMS320C5x.</i>	
B.1	Using the Instruction Set Comparison Table	B-2
B.1.1	An Example of a Table Entry	B-2
B.1.2	Symbols and Acronyms Used in the Table	B-3
B.2	Enhanced Instructions	B-5
B.3	Instruction Set Comparison Table	B-6
C	Program Examples	C-1
	<i>Presents examples of assembly language programs for the TMS320C2xx, primarily examples for the on-chip peripherals.</i>	
C.1	About These Program Examples	C-2
C.2	Shared Program Code	C-5
C.3	Task-Specific Program Code	C-8
C.4	Introduction to Generating Boot Loader Code	C-23

D	Submitting ROM Codes to TI	D-1
	<i>Explains the process for submitting custom program code to TI for designing masks for the on-chip ROM on a TMS320 DSP.</i>	
E	Design Considerations for Using XDS510 Emulator	E-1
	<i>Describes the JTAG emulator cable and how to construct a 14-pin connector on your target system and how to connect the target system to the emulator.</i>	
E.1	Designing Your Target System's Emulator Connector (14-Pin Header)	E-2
E.2	Bus Protocol	E-4
E.3	Emulator Cable Pod	E-5
E.4	Emulator Cable Pod Signal Timing	E-6
E.5	Emulation Timing Calculations	E-7
E.6	Connections Between the Emulator and the Target System	E-10
	E.6.1 Buffering Signals	E-10
	E.6.2 Using a Target-System Clock	E-12
	E.6.3 Configuring Multiple Processors	E-13
E.7	Physical Dimensions for the 14-Pin Emulator Connector	E-14
E.8	Emulation Design Considerations	E-16
	E.8.1 Using Scan Path Linkers	E-16
	E.8.2 Emulation Timing Calculations for a Scan Path Linker (SPL)	E-18
	E.8.3 Using Emulation Pins	E-20
	E.8.4 Performing Diagnostic Applications	E-24
F	Glossary	F-1
	<i>Explains terms, abbreviations, and acronyms used throughout this book.</i>	

Figures

1-1	TMS320 Family	1-3
2-1	Overall Block Diagram of the 'C2xx	2-2
2-2	Bus Structure Block Diagram	2-4
3-1	Block Diagram of the Input Scaling, Central Arithmetic Logic, and Multiplication Sections of the CPU	3-2
3-2	Block Diagram of the Input Scaling Section	3-3
3-3	Operation of the Input Shifter for SXM = 0	3-4
3-4	Operation of the Input Shifter for SXM = 1	3-4
3-5	Block Diagram of the Multiplication Section	3-5
3-6	Block Diagram of the Central Arithmetic Logic Section	3-8
3-7	Shifting and Storing the High Word of the Accumulator	3-11
3-8	Shifting and Storing the Low Word of the Accumulator	3-11
3-9	ARAU and Related Logic	3-12
3-10	Status Register ST0	3-15
3-11	Status Register ST1	3-15
4-1	Interface With External Program Memory	4-6
4-2	Pages of Data Memory	4-7
4-3	Interface With External Local Data Memory	4-10
4-4	GREG Register Set to Configure 8K for Global Data Memory	4-12
4-5	Global and Local Data Memory for GREG = 11100000	4-12
4-6	Using 8000h–FFFFh for Local and Global External Memory	4-13
4-7	Simplified Block Diagram of Boot Loader Operation	4-14
4-8	Connecting the EPROM to the Processor	4-15
4-9	Storing the Program in the EPROM	4-17
4-10	Program Code Transferred From 8-Bit EPROM to 16-Bit RAM	4-19
4-11	Interrupt Vectors Transferred First During Boot Load	4-20
4-12	I/O Address Map for the 'C2xx	4-23
4-13	I/O Port Interface Circuitry	4-26
4-14	$\overline{\text{HOLD}}$ Deasserted Before Reset Deasserted	4-29
4-15	Reset Deasserted Before $\overline{\text{HOLD}}$ Deasserted	4-30
4-16	'C203 Address Map	4-32
4-17	'C204 Address Map	4-35
5-1	Program-Address Generation Block Diagram	5-2
5-2	A Push Operation	5-5
5-3	A Pop Operation	5-6
5-4	4-Level Pipeline Operation	5-7

5-5	$\overline{\text{INT2}}/\overline{\text{INT3}}$ Request Flow Chart	5-18
5-6	Maskable Interrupt Operation Flow Chart	5-20
5-7	'C2xx Interrupt Flag Register (IFR) — Data-Memory Address 0006h	5-21
5-8	'C2xx Interrupt Mask Register (IMR) — Data-Memory Address 0004h	5-23
5-9	'C2xx Interrupt Control Register (ICR) — I/O-Space Address FFECh	5-26
5-10	Nonmaskable Interrupt Operation Flow Chart	5-29
6-1	Instruction Register Contents for Example 6-1	6-2
6-2	Two Words Loaded Consecutively to the Instruction Register in Example 6-2	6-3
6-3	Pages of Data Memory	6-4
6-4	Instruction Register (IR) Contents in Direct Addressing Mode	6-5
6-5	Generation of Data Addresses in Direct Addressing Mode	6-5
6-6	Instruction Register Content in Indirect Addressing	6-12
7-1	Bit Numbers and Their Corresponding Bit Codes for BIT Instruction	7-45
7-2	Bit Numbers and Their Corresponding Bit Codes for BITT Instruction	7-47
7-3	LST #0 Operation	7-87
7-4	LST #1 Operation	7-88
8-1	Using the Internal Oscillator	8-4
8-2	Using an External Oscillator	8-5
8-3	'C2xx CLK Register — I/O-Space Address FFE8h	8-7
8-4	Timer Functional Block Diagram	8-8
8-5	'C2xx Timer Control Register (TCR) — I/O-Space Address FFF8h	8-11
8-6	'C2xx Wait-State Generator Control Register (WSGR) — I/O-Space Address FFFCh	8-15
8-7	$\overline{\text{BIO}}$ Timing Diagram Example	8-18
9-1	Synchronous Serial Port Block Diagram	9-3
9-2	2-Way Serial Port Transfer With External Frame Sync and External Clock	9-5
9-3	Synchronous Serial Port Control Register (SSPCR) — I/O-Space Address FFF1h	9-8
9-4	Burst Mode Transmission With Internal Frame Sync and Multiple Words in the Buffer	9-17
9-5	Burst Mode Transmission With External Frame Sync	9-19
9-6	Continuous Mode Transmission With Internal Frame Sync	9-21
9-7	Continuous Mode Transmission With External Frame Sync	9-23
9-8	Burst Mode Reception	9-25
9-9	Continuous Mode Reception	9-26
9-10	Test Bits in the SSPCR	9-27
10-1	Asynchronous Serial Port Block Diagram	10-3
10-2	Typical Serial Link Between a 'C2xx Device and a Host CPU	10-6
10-3	Asynchronous Serial Port Control Register (ASPCR) — I/O-Space Address FFF5h	10-7
10-4	I/O Status Register (IOSR) — I/O-Space Address FFF6h	10-10
10-5	Example of the Logic for Pins IO0–IO3	10-15
10-6	Data Transmit	10-19
10-7	Data Receive	10-20
11-1	'C209 Address Maps	11-6

11-2	'C209 Interrupt Flag Register (IFR) — Data-Memory Address 0006h	11-12
11-3	'C209 Interrupt Mask Register (IMR) — Data-Memory Address 0004h	11-13
11-4	'C209 Timer Control Register (TCR) — I/O Address FFFCh	11-15
11-5	'C209 Wait-State Generator Control Register (WSGR) — I/O Address FFFFh	11-17
C-1	Procedure for Generating Executable Files	C-2
D-1	TMS320 ROM Code Submittal Flow Chart	D-2
E-1	14-Pin Header Signals and Header Dimensions	E-2
E-2	Emulator Cable Pod Interface	E-5
E-3	Emulator Cable Pod Timings	E-6
E-4	Emulator Connections Without Signal Buffering	E-10
E-5	Emulator Connections With Signal Buffering	E-11
E-6	Target-System-Generated Test Clock	E-12
E-7	Multiprocessor Connections	E-13
E-8	Pod/Connector Dimensions	E-14
E-9	14-Pin Connector Dimensions	E-15
E-10	Connecting a Secondary JTAG Scan Path to a Scan Path Linker	E-17
E-11	EMU0/1 Configuration to Meet Timing Requirements of Less Than 25 ns	E-21
E-12	Suggested Timings for the EMU0 and EMU1 Signals	E-22
E-13	EMU0/1 Configuration With Additional AND Gate to Meet Timing Requirements of Greater Than 25 ns	E-23
E-14	EMU0/1 Configuration Without Global Stop	E-24
E-15	TBC Emulation Connections for n JTAG Scan Paths	E-25

Tables

1-1	Typical Applications for TMS320 DSPs	1-4
1-2	'C2xx Generation Summary	1-5
2-1	Program and Data Memory on the TMS320C2xx Devices	2-7
2-2	Serial Ports on the 'C2xx Devices	2-12
3-1	Product Shift Modes for the Product-Scaling Shifter	3-7
3-2	Bit Fields of Status Registers ST0 and ST1	3-16
4-1	Pins for Interfacing With External Memory and I/O Spaces	4-3
4-2	Data Page 0 Address Map	4-8
4-3	Global Data Memory Configurations	4-11
4-4	On-Chip Registers Mapped to I/O Space	4-24
4-5	'C203 Program-Memory Configuration Options	4-33
4-6	'C203 Data-Memory Configuration Options	4-34
4-7	'C204 Program-Memory Configuration Options	4-37
4-8	'C204 Data-Memory Configuration Options	4-37
5-1	Program-Address Generation Summary	5-3
5-2	Address Loading to the Program Counter	5-4
5-3	Conditions for Conditional Calls and Returns	5-10
5-4	Groupings of Conditions	5-11
5-5	'C2xx Interrupt Locations and Priorities	5-16
5-6	Reset Values of On-Chip Registers Mapped to Data Space	5-35
5-7	Reset Values of On-Chip Registers Mapped to I/O Space	5-35
6-1	Indirect Addressing Operands	6-10
6-2	Effects of the ARU Code on the Current Auxiliary Register	6-13
6-3	Field Bits and Notation for Indirect Addressing	6-14
7-1	Accumulator, Arithmetic, and Logic Instructions	7-4
7-2	Auxiliary Register Instructions	7-7
7-3	TREG, PREG, and Multiply Instructions	7-7
7-4	Branch Instructions	7-8
7-5	Control Instructions	7-9
7-6	I/O and Memory Instructions	7-10
7-7	Product Shift Modes	7-37
7-8	Product Shift Modes	7-167
8-1	Peripheral Register Locations and Reset Conditions	8-2
8-2	'C2xx Input Clock Modes	8-6
8-3	'C2xx Timer Run/Emulation Modes	8-11
8-4	Setting the Number of Wait States With the 'C2xx WSGR Bits	8-16

9-1	SSP Interface Pins	9-4
9-2	Run and Emulation Modes	9-9
9-3	Controlling Transmit Interrupt Generation by Writing to Bits FT1 and FT0	9-9
9-4	Controlling Receive Interrupt Generation by Writing to Bits FR1 and FR0	9-10
9-5	Selecting Transmit Clock and Frame Sync Sources	9-13
9-6	Run and Emulation Modes	9-28
10-1	Asynchronous Serial Port Interface Pins	10-4
10-2	Common Baud Rates and the Corresponding BRD Values	10-14
10-3	Configuring Pins IO0–IO3 with ASPCR Bits CIO0–CIO3	10-15
10-4	Viewing the Status of Pins IO0–IO3 With IOSR Bits IO0–IO3 and DIO0–DIO3	10-16
11-1	'C209 Program-Memory Configuration Options	11-8
11-2	'C209 Data-Memory Configuration Options	11-9
11-3	'C209 On-Chip Registers Mapped to I/O Space	11-9
11-4	'C209 Interrupt Locations and Priorities	11-10
11-5	'C209 Input Clock Modes	11-15
A-1	Reset Values of the Status Registers	A-2
A-2	Addresses and Reset Values of On-Chip Registers Mapped to Data Space	A-2
A-3	Addresses and Reset Values of On-Chip Registers Mapped to I/O Space	A-2
B-1	Symbols and Acronyms Used in the Instruction Set Summary	B-3
B-2	Summary of Enhanced Instructions	B-5
C-1	Shared Programs in This Appendix	C-3
C-2	Task-Specific Programs in This Appendix	C-3
E-1	14-Pin Header Signal Descriptions	E-3
E-2	Emulator Cable Pod Timing Parameters	E-6

Examples

4-1	An Interrupt Service Routine Supporting $\overline{\text{INT1}}$ and $\overline{\text{HOLD}}$	4-28
6-1	RPT Instruction Using Short-Immediate Addressing	6-2
6-2	ADD Instruction Using Long-Immediate Addressing	6-2
6-3	Using Direct Addressing with ADD (Shift of 0 to 15)	6-7
6-4	Using Direct Addressing with ADD (Shift of 16)	6-7
6-5	Using Direct Addressing with ADDC	6-8
6-6	Selecting a New Current Auxiliary Register	6-12
6-7	No Increment or Decrement	6-15
6-8	Increment by 1	6-15
6-9	Decrement by 1	6-16
6-10	Increment by Index Amount	6-16
6-11	Decrement by Index Amount	6-16
6-12	Increment by Index Amount With Reverse Carry Propagation	6-16
6-13	Decrement by Index Amount With Reverse Carry Propagation	6-16
C-1	Generic Command File (c203.cmd)	C-5
C-2	Header File With I/O Register Declarations (init.h)	C-6
C-3	Header File With Interrupt Vector Declarations (vector.h)	C-7
C-4	Implementing Simple Delay Loops (delay.asm)	C-8
C-5	Testing and Using the Timer (timer.asm)	C-9
C-6	Testing and Using Interrupt $\overline{\text{INT1}}$ (intr1.asm)	C-10
C-7	Implementing a HOLD Operation (hold.asm)	C-11
C-8	Testing and Using Interrupts $\overline{\text{INT2}}$ and $\overline{\text{INT3}}$ (intr23.asm)	C-12
C-9	Asynchronous Serial Port Transmission (uart.asm)	C-13
C-10	Loopback to Verify Transmissions of Asynchronous Serial Port (echo.asm)	C-14
C-11	Testing and Using Automatic Baud-Rate Detection on Asynchronous Serial Port (autobaud.asm)	C-16
C-12	Testing and Using Asynchronous Serial Port Delta Interrupts (bitio.asm)	C-18
C-13	Synchronous Serial Port Continuous Mode Transmission (ssp.asm)	C-20
C-14	Using Synchronous Serial Port With Codec Device (ad55.asm)	C-21
C-15	Linker Command File	C-24
C-16	Hex Conversion Utility Command File	C-24
E-1	Key Timing for a Single-Processor System Without Buffers	E-8
E-2	Key Timing for a Single- or Multiple-Processor System With Buffered Input and Output	E-8
E-3	Key Timing for a Single-Processor System Without Buffering (SPL)	E-19
E-4	Key Timing for a Single- or Multiprocessor-System With Buffered Input and Output (SPL)	E-19

Cautions

- Obtain the Proper Timing Information 4-5
- Do Not Write to Test/Emulation Addresses 4-8
- Obtain the Proper Timing Information 4-9
- Do Not Write to Reserved Addresses 4-24
- Do Not Write to Reserved Addresses 4-33
- Do Not Write to Reserved Addresses 4-36
- Initialize the DP in All Programs 6-5
- Do Not Write to Reserved Addresses 11-7

Introduction

The TMS320C2xx ('C2xx) is one of several fixed-point generations of DSPs in the TMS320 family. The 'C2xx is source-code compatible with the TMS320C2x. Much of the code written for the 'C2x can be reassembled to run on a 'C2xx device. In addition, the 'C2xx generation is upward compatible with the 'C5x generation of DSPs.

Topic	Page
1.1 TMS320 Family	1-2
1.2 TMS320C2xx Generation	1-5
1.3 Key Features of the TMS320C2xx	1-6

1.1 TMS320 Family

The TMS320 family consists of fixed-point, floating-point, and multiprocessor digital signal processors (DSPs). TMS320 DSPs have an architecture designed specifically for real-time signal processing. The following characteristics make this family the ideal choice for a wide range of processing applications:

- Flexible instruction sets
- High-speed performance
- Innovative parallel architectures
- Cost effectiveness

1.1.1 History, Development, and Advantages of TMS320 DSPs

In 1982, Texas Instruments introduced the TMS32010, the first fixed-point DSP in the TMS320 family. Before the end of the year, *Electronic Products* magazine awarded the TMS32010 the title “Product of the Year”. Today, the TMS320 family consists of these generations: 'C1x, 'C2x, 'C2xx, 'C5x, and 'C54x fixed-point DSPs; 'C3x and 'C4x floating-point DSPs; and 'C8x multiprocessor DSPs. See Figure 1–1.

Devices within a generation of the TMS320 family have the same CPU structure but different on-chip memory and peripheral configurations. Spin-off devices use new combinations of on-chip memory and peripherals to satisfy a wide range of needs in the worldwide electronics market. By integrating memory and peripherals onto a single chip, TMS320 devices reduce system cost and save circuit board space.

Figure 1–1. TMS320 Family

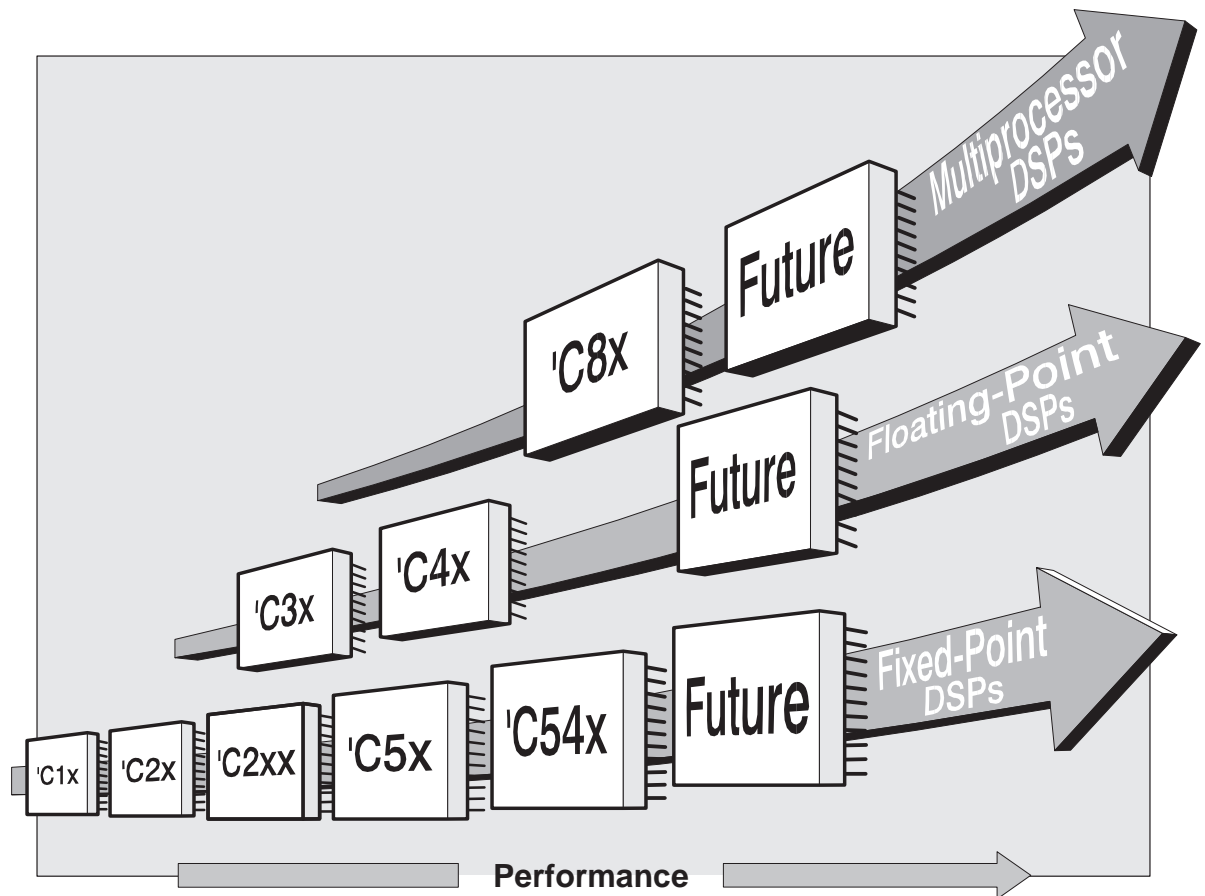

1.1.2 Typical Applications for the TMS320 Family

Table 1–1 lists some typical applications for the TMS320 family of DSPs. The TMS320 DSPs offer adaptable approaches to traditional signal-processing problems such as filtering and vocoding. They also support complex applications that often require multiple operations to be performed simultaneously.

Table 1–1. Typical Applications for TMS320 DSPs

Automotive	Consumer	Control
Adaptive ride control	Digital radios/TVs	Disk drive control
Antiskid brakes	Educational toys	Engine control
Cellular telephones	Music synthesizers	Laser printer control
Digital radios	Pagers	Motor control
Engine control	Power tools	Robotics control
Global positioning	Radar detectors	Servo control
Navigation	Solid-state answering machines	
Vibration analysis		
Voice commands		
General-Purpose	Graphics/Imaging	Industrial
Adaptive filtering	3-D rotation	Numeric control
Convolution	Animation/digital maps	Power-line monitoring
Correlation	Homomorphic processing	Robotics
Digital filtering	Image compression/transmission	Security access
Fast Fourier transforms	Image enhancement	
Hilbert transforms	Pattern recognition	
Waveform generation	Robot vision	
Windowing	Workstations	
Instrumentation	Medical	Military
Digital filtering	Diagnostic equipment	Image processing
Function generation	Fetal monitoring	Missile guidance
Pattern matching	Hearing aids	Navigation
Phase-locked loops	Patient monitoring	Radar processing
Seismic processing	Prosthetics	Radio frequency modems
Spectrum analysis	Ultrasound equipment	Secure communications
Transient analysis		Sonar processing
Telecommunications		Voice/Speech
1200- to 28 800-bps modems	Faxing	Speaker verification
Adaptive equalizers	Line repeaters	Speech enhancement
ADPCM transcoders	Personal communications systems (PCS)	Speech recognition
Cellular telephones	Personal digital assistants (PDA)	Speech synthesis
Channel multiplexing	Speaker phones	Speech vocoding
Data encryption	Spread spectrum communications	Text-to-speech applications
Digital PBXs	Video conferencing	Voice mail
Digital speech interpolation (DSI)	X.25 packet switching	
DTMF encoding/decoding		
Echo cancellation		

1.2 TMS320C2xx Generation

Texas Instruments uses static CMOS integrated-circuit technology to fabricate the TMS320C2xx DSPs. The architectural design of the 'C2xx is based on that of the 'C5x. The operational flexibility and speed of the 'C2xx and 'C5x are a result of an advanced, modified Harvard architecture (which has separate buses for program and data memory), a multilevel pipeline, on-chip peripherals, on-chip memory, and a highly specialized instruction set. The 'C2xx performs up to 40 MIPS (million instructions per second).

The 'C2xx generation offers the following benefits:

- Enhanced TMS320 architectural design for increased performance and versatility
- Modular architectural design for fast development of additional spin-off devices
- Advanced IC processing technology for increased performance
- Fast and easy performance upgrades for 'C1x and 'C2x source code, which is upward compatible with 'C2xx source code
- Enhanced instruction set for faster algorithms and for optimized high-level language operation
- New static design techniques for minimizing power consumption

Table 1–2 provides an overview of the basic features of the 'C2xx DSPs.

Table 1–2. 'C2xx Generation Summary

Device	Cycle Time (ns)	On-Chip Memory			Serial Ports		Timers	Package
		RAM	ROM	Flash	Synch.	Asynch.		
TMS320C203	25/35/50	544			1	1	1	100 TQFP†
TMS320C204	25/35/50	544	4K		1	1	1	100 TQFP†
TMS320F206	25/35/50	4.5K		32K	1	1	1	100 TQFP†
TMS320C209	35/50	4.5K	4K		–	–	1	80 TQFP†

† TQFP = Thin quad flat pack

1.3 Key Features of the TMS320C2xx

Key features on the various 'C2xx devices are:

- Speed:
 - 50-, 35-, or 25-ns execution time of a single-cycle instruction
 - 20, 28.5, or 40 MIPS
- Code compatibility with other TMS320 fixed-point devices:
 - Source-code compatible with all 'C1x and 'C2x devices
 - Upward compatible with the 'C5x devices
- Memory:
 - 224K words of addressable memory space (64K words of program space, 64K words of data space, 64K words of I/O space, and 32K words of global space)
 - 544 words of dual-access on-chip RAM (288 words for data and 256 words for program/data)
 - 4K words on-chip ROM or 32K words on-chip flash memory (on selected devices)
 - 4K words of single-access on-chip RAM (on selected devices)
- CPU:
 - 32-bit arithmetic logic unit (CALU)
 - 32-bit accumulator
 - 16-bit × 16-bit parallel multiplier with 32-bit product capability
 - Three scaling shifters
 - Eight 16-bit auxiliary registers with a dedicated arithmetic unit for indirect addressing of data memory
- Program control:
 - 4-level pipeline operation
 - 8-level hardware stack
 - User-maskable interrupt lines

- Instruction set:
 - Single-instruction repeat operation
 - Single-cycle multiply/accumulate instructions
 - Memory block move instructions for better program/data management
 - Indexed-addressing capability
 - Bit-reversed indexed-addressing capability for radix-2 FFTs
- On-chip peripherals:
 - Software-programmable timer
 - Software-programmable wait-state generator for program, data, and I/O memory spaces
 - Oscillator and phase-locked loop (PLL) to implement clock options: $\times 1$, $\times 2$, $\times 4$, and $\div 2$ (only $\times 2$ and $\div 2$ available on 'C209)
 - CLK register for turning the CLKOUT1 pin on and off (not available on 'C209)
 - Synchronous serial port (not available on 'C209)
 - Asynchronous serial port (not available on 'C209)
- On-chip scanning-logic circuitry (IEEE Standard 1149.1) for emulation and testing purposes
- Power:
 - 5- or 3.3-V static CMOS technology
 - Power-down mode to reduce power consumption
- Packages:
 - 100-pin TQFP (thin quad flat pack)
 - 80-pin TQFP for the 'C209

Architectural Overview

This chapter provides an overview of the architectural structure and components of the 'C2xx. The 'C2xx DSPs use an advanced, modified Harvard architecture that maximizes processing power by maintaining separate bus structures for program memory and data memory. The three main components of the 'C2xx are the central processing unit (CPU), memory, and on-chip peripherals.

Figure 2–1 shows an overall block diagram of the 'C2xx.

Note:

All 'C2xx devices use the same central processing unit (CPU), bus structure, and instruction set, but the 'C209 has some notable differences. For example, although certain peripheral control registers have the same names on all 'C2xx devices, these registers are located at different I/O addresses on the 'C209. See Chapter 11 for a detailed description of the differences on the 'C209.

Topic	Page
2.1 'C2xx Bus Structure	2-3
2.2 Central Processing Unit	2-5
2.3 Memory and I/O Spaces	2-7
2.4 Program Control	2-10
2.5 On-Chip Peripherals	2-11
2.6 Scanning-Logic Circuitry	2-13

Figure 2–1. Overall Block Diagram of the 'C2xx

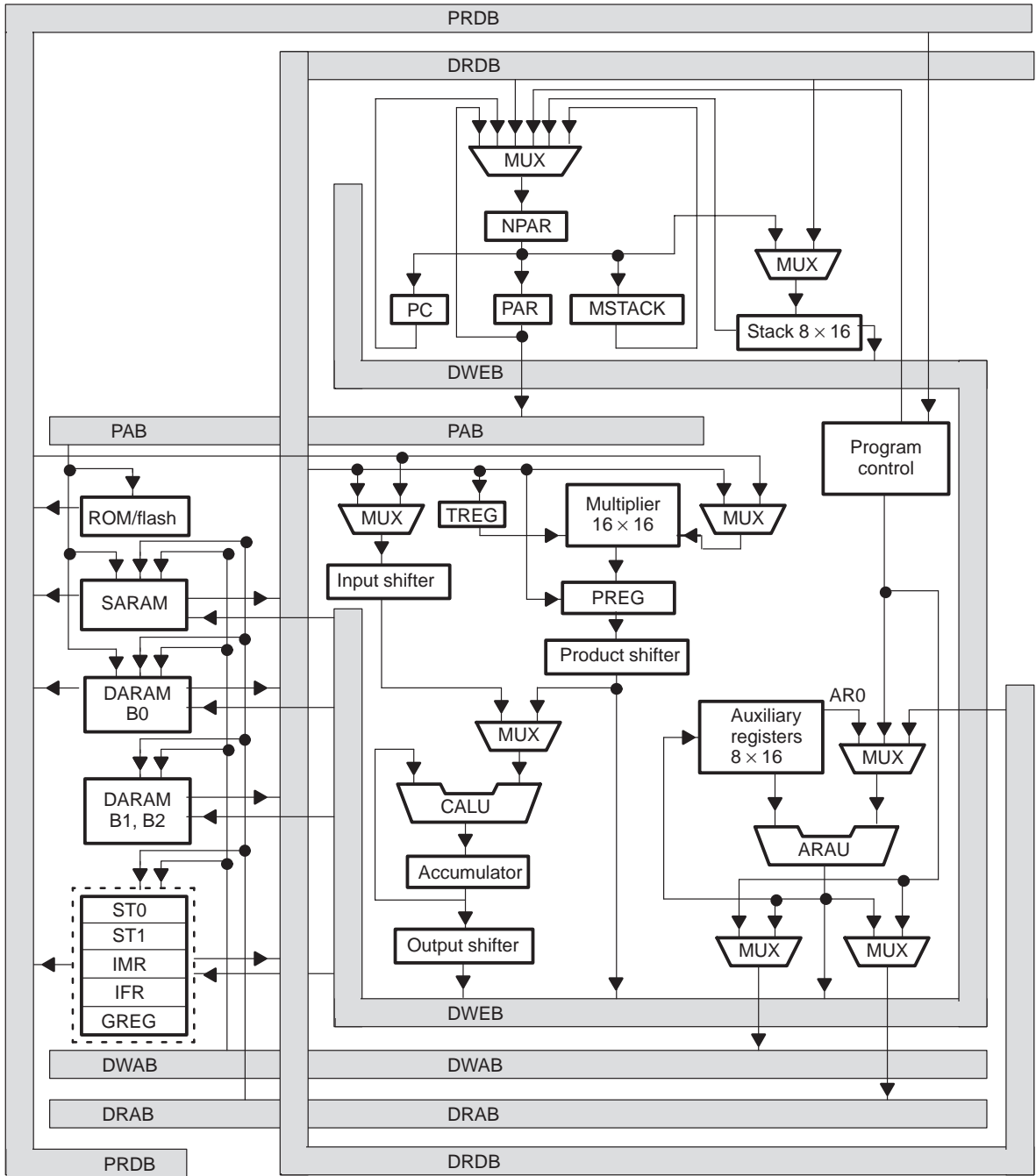

Note: The I/O-mapped (peripheral) registers are not part of the core; they are accessed as shown in Figure 2–2 on page 2-4.

2.1 'C2xx Bus Structure

Figure 2–2 shows a block diagram of the 'C2xx bus structure. The 'C2xx internal architecture is built around six 16-bit buses:

- ❑ **PAB.** The *program address bus* provides addresses for both reads from and writes to program memory.
- ❑ **DRAB.** The *data-read address bus* provides addresses for reads from data memory.
- ❑ **DWAB.** The *data-write address bus* provides addresses for writes to data memory.
- ❑ **PRDB.** The *program read bus* carries instruction code and immediate operands, as well as table information, from program memory to the CPU.
- ❑ **DRDB.** The *data read bus* carries data from data memory to the central arithmetic logic unit (CALU) and the auxiliary register arithmetic unit (ARAU).
- ❑ **DWEB.** The *data write bus* carries data to both program memory and data memory.

Having separate address buses for data reads (DRAB) and data writes (DWAB) allows the CPU to read and write in the same machine cycle.

Separate program and data spaces allow simultaneous access to program instructions and data. For example, while data is multiplied, a previous product can be added to the accumulator, and, at the same time, a new address can be generated. Such parallelism supports a set of arithmetic, logic, and bit-manipulation operations that can all be performed in a single machine cycle. In addition, the 'C2xx includes control mechanisms to manage interrupts, repeated operations, and function/subroutine calls.

All 'C2xx devices share the same CPU and bus structure; however, each device has different on-chip memory configurations and on-chip peripherals.

Figure 2–2. Bus Structure Block Diagram

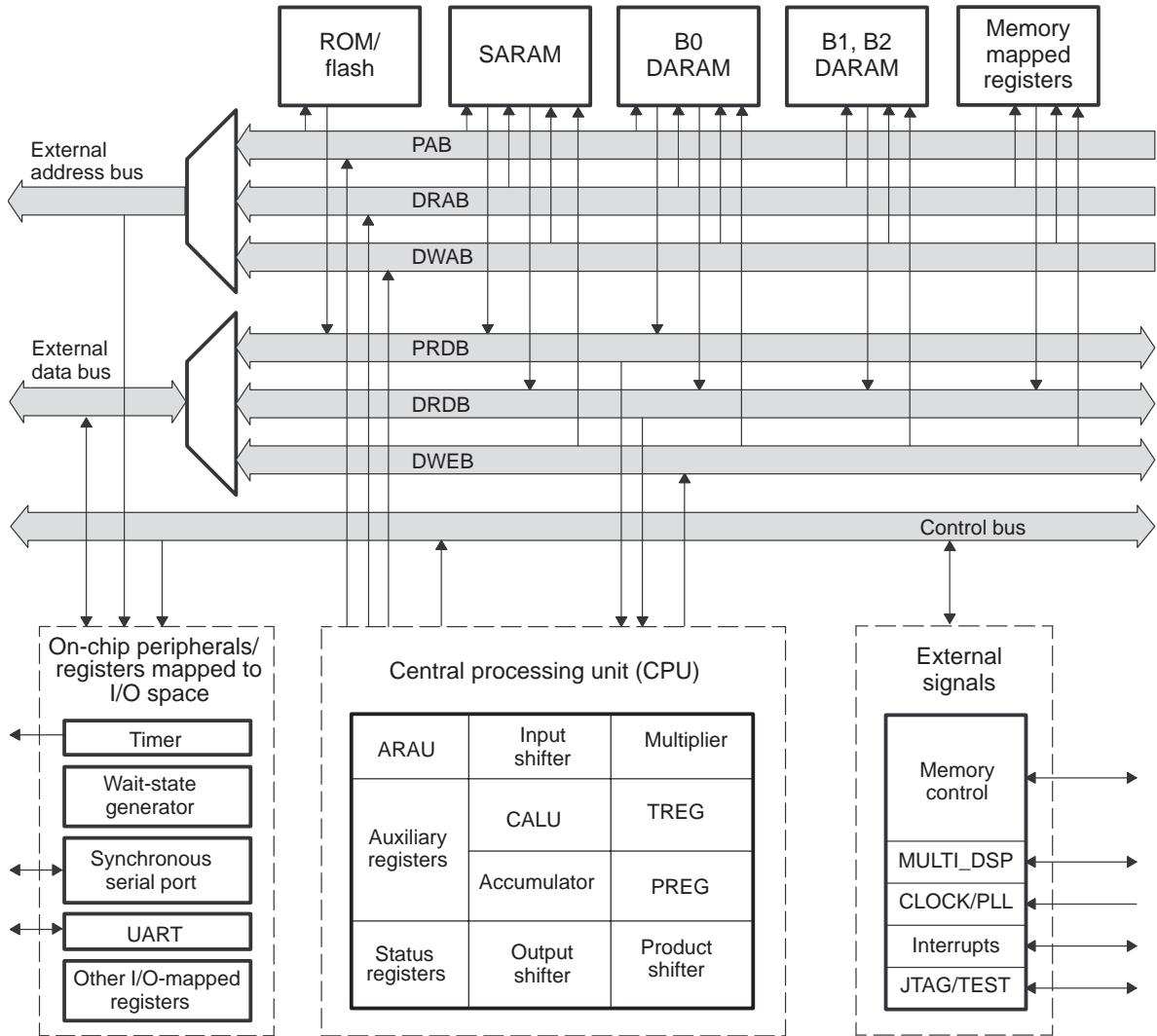

2.2 Central Processing Unit

The CPU is the same on all the 'C2xx devices. The 'C2xx CPU contains:

- A 32-bit central arithmetic logic unit (CALU)
- A 32-bit accumulator
- Input and output data-scaling shifters for the CALU
- A 16-bit \times 16-bit multiplier
- A product-scaling shifter
- Data-address generation logic, which includes eight auxiliary registers and an auxiliary register arithmetic unit (ARAU)
- Program-address generation logic

2.2.1 Central Arithmetic Logic Unit (CALU) and Accumulator

The 'C2xx performs 2s-complement arithmetic using the 32-bit CALU. The CALU uses 16-bit words taken from data memory or derived from an immediate instruction, or it uses the 32-bit result from the multiplier. In addition to arithmetic operations, the CALU can perform Boolean operations.

The accumulator stores the output from the CALU; it can also provide a second input to the CALU. The accumulator is 32 bits wide and is divided into a high-order word (bits 31 through 16) and a low-order word (bits 15 through 0). Assembly language instructions are provided for storing the high- and low-order accumulator words to data memory.

2.2.2 Scaling Shifters

The 'C2xx has three 32-bit shifters that allow for scaling, bit extraction, extended arithmetic, and overflow-prevention operations:

- Input data-scaling shifter (input shifter).** This shifter left shifts 16-bit input data by 0 to 16 bits to align the data to the 32-bit input of the CALU.
- Output data-scaling shifter (output shifter).** This shifter can left shift output from the accumulator by 0 to 7 bits before the output is stored to data memory. The content of the accumulator remains unchanged.
- Product-scaling shifter (product shifter).** The product register (PREG) receives the output of the multiplier. The product shifter shifts the output of the PREG before that output is sent to the input of the CALU. The product shifter has four product shift modes (no shift, left shift by one bit, left shift by four bits, and right shift by 6 bits), which are useful for performing multiply/accumulate operations, performing fractional arithmetic, or justifying fractional products.

2.2.3 Multiplier

The on-chip multiplier performs 16-bit \times 16-bit 2s-complement multiplication with a 32-bit result. In conjunction with the multiplier, the 'C2xx uses the 16-bit temporary register (TREG) and the 32-bit product register (PREG). The TREG always supplies one of the values to be multiplied. The PREG receives the result of each multiplication.

Using the multiplier, TREG, and PREG, the 'C2xx efficiently performs fundamental DSP operations such as convolution, correlation, and filtering. The effective execution time of each multiplication instruction can be as short as one CPU cycle.

2.2.4 Auxiliary Register Arithmetic Unit (ARAU) and Auxiliary Registers

The ARAU generates data memory addresses when an instruction uses indirect addressing (see Chapter 6, *Addressing Modes*) to access data memory. The ARAU is supported by eight auxiliary registers (AR0 through AR7), each of which can be loaded with a 16-bit value from data memory or directly from an instruction word. Each auxiliary register value can also be stored to data memory. The auxiliary registers are referenced by a 3-bit auxiliary register pointer (ARP) embedded in status register ST0.

2.3 Memory and I/O Spaces

The 'C2xx memory is organized into four individually selectable spaces: program, local data, global data, and I/O. These spaces form an address range of 224K words.

All 'C2xx devices include 288 words of dual-access RAM (DARAM) for data memory and 256 words of data/program DARAM. Depending on the device, it may also have data/program single-access RAM (SARAM) and read-only memory (ROM) or flash memory. Table 2–1 shows how much ROM, flash memory, DARAM, and SARAM are available on the different 'C2xx devices.

Table 2–1. Program and Data Memory on the TMS320C2xx Devices

Memory Type	'C203	'C204	'F206	'C209
ROM (words)	–	4K	–	4K
Flash memory (words)	–	–	32K	–
DARAM (words)	544	544	544	544
Data (words)	288	288	288	288
Data/program (words)	256	256	256	256
SARAM (words)	–	–	4K	4K

The 'C2xx also has CPU registers that are mapped in data memory space and peripheral registers that are mapped in on-chip I/O space. The 'C2xx memory types and features are introduced in the subsections following this paragraph. For more details about the configuration and use of the 'C2xx memory and I/O space, see Chapter 4, *Memory and I/O Space*.

2.3.1 Dual-Access On-Chip RAM

All 'C2xx devices have 544 words \times 16-bits of on-chip DARAM, which can be accessed twice per machine cycle. This memory is primarily intended to hold data but, when needed, can also hold programs. It can be configured in one of two ways:

- All 544 words are configured as data memory.
- 288 words are configured as data memory, and 256 words are configured as program memory.

Because DARAM can be accessed twice per cycle, it improves the speed of the CPU. The CPU operates within a four-cycle pipeline. In this pipeline, the

CPU reads data on the third cycle and writes data on the fourth cycle. However, DARAM allows the CPU to write and read in one cycle; the CPU writes to DARAM on the master phase of the cycle and reads from DARAM on the slave phase. For example, suppose two instructions, A and B, store the accumulator value to DARAM and load the accumulator with a new value from DARAM. Instruction A stores the accumulator value during the master phase of the CPU cycle, and instruction B loads the new value to the accumulator during the slave phase. Because part of the dual-access operation is a write, it only applies to RAM.

2.3.2 Single-Access On-Chip Program/Data RAM

Some of the 'C2xx devices have 4K 16-bit words of single-access RAM (SARAM). The addresses associated with the SARAM can be used for both data memory and program memory and are software- or hardware-configurable (depending on the device) to either external memory or the internal SARAM. When configured as external, these addresses can be used for off-chip data and program memory. Code can be booted from off-chip ROM and then executed at full speed once it is loaded into the on-chip SARAM. Because the SARAM can be mapped to program and/or data memory, the SARAM allows for more flexible address mapping than the DARAM block.

SARAM is accessed only once per CPU cycle. When the CPU requests multiple accesses, the SARAM schedules the accesses by providing a not-ready condition to the CPU and then executing the accesses one per cycle. For example, if the instruction sequence involves storing the accumulator value and then loading a value to the accumulator, it would take two cycles to complete in SARAM, compared to one cycle in DARAM.

2.3.3 Factory-Masked On-Chip ROM

Some of the 'C2xx devices feature an on-chip, 4K 16-bit words of programmable ROM. The ROM can be selected during reset by driving the $\overline{MP/\overline{MC}}$ pin low. If the ROM is not selected, the device starts its execution from off-chip memory.

If you want a custom ROM, you can provide the code or data to be programmed into the ROM in object file format, and Texas Instruments will generate the appropriate process mask to program the ROM. See Appendix D for details on how to submit ROM code to Texas Instruments.

2.3.4 Flash Memory

Some of the 'C2xx devices feature on-chip blocks of flash memory, which is electronically erasable and programmable, and non-volatile. Each block of flash memory will have a set of control registers that allow for erasing, programming, and testing of that block. The flash memory blocks can be selected during reset by driving the MP/\overline{MC} pin low. If the flash memory is not selected, the device starts its execution from off-chip memory.

2.4 Program Control

Several features provide program control:

- ❑ The program controller of the CPU decodes instructions, manages the pipeline, stores the status of operations, and decodes conditional operations. Elements involved in program control are the program counter, the status registers, the stack, and the address-generation logic.
- ❑ Software mechanisms used for program control include branches, calls, conditional instructions, a repeat instruction, reset, and interrupts.

For descriptions of these program control features, see Chapter 5, *Program Control*.

2.5 On-Chip Peripherals

All the 'C2xx devices have the same CPU, but different on-chip peripherals are connected to their CPUs. The on-chip peripherals featured on the 'C2xx devices are:

- Clock generator (an oscillator and a phase lock loop circuit)
- CLK register for turning the CLKOUT1 pin on and off
- Timer
- Wait-state generator
- General-purpose input/output (I/O) pins
- Synchronous serial port
- Asynchronous serial port

2.5.1 Clock Generator

The clock generator consists of an internal oscillator and an internal phase lock loop (PLL) circuit. The clock generator can be driven internally by connecting the DSP to a crystal resonator circuit, or it can be driven by an external clock source. The PLL circuit generates an internal CPU clock by multiplying the clock source by a specified factor. Thus, you can use a clock source with a lower frequency than that of the CPU. The clock generator is discussed in Section 8.2, on page 8-4.

2.5.2 CLKOUT1-Pin Control (CLK) Register

The 'C2xx CLK register controls whether the master clock output signal (CLKOUT1) is available at the CLKOUT1 pin.

2.5.3 Hardware Timer

The 'C2xx features a 16-bit down-counting timer with a 4-bit prescaler. Timer control bits can stop, start, reload, and determine the prescaler count for the timer. For more information, see Section 8.4, *Timer*, on page 8-8.

2.5.4 Software-Programmable Wait-State Generator

Software-programmable wait-state logic is incorporated (without any external hardware) for interfacing with slower off-chip memory and I/O devices. The 'C209 wait-state generator generates zero or one wait states; the wait-state generator on other 'C2xx devices generates zero to seven wait states. For more information, see Section 8.5, *Wait-State Generator*, on page 8-14.

2.5.5 General-Purpose I/O Pins

The 'C2xx has pins that provide general-purpose input or output signals. All 'C2xx devices have a general-purpose input pin, $\overline{\text{BIO}}$, and a general-purpose output pin, XF. Except for the 'C209, the 'C2xx devices also have pins IO0, IO1, IO2, and IO3, which are connected to corresponding bits (IO0–IO3) mapped into the on-chip I/O space. These bits can be individually configured as inputs or outputs. For more information on the general-purpose pins, see Section 8.6, on page 8-17.

2.5.6 Serial Ports

The serial ports available on the 'C2xx vary by device, but two types of serial ports are represented: synchronous and asynchronous. See Table 2–2 for the number of each kind on the various 'C2xx devices. The subsections following the table provide an introduction to the two types of serial ports.

Table 2–2. Serial Ports on the 'C2xx Devices

Serial Ports	'C203	'C204	'F206	'C209
Synchronous	1	1	1	–
Asynchronous	1	1	1	–

Synchronous serial port (SSP)

The 'C2xx synchronous serial port (SSP) communicates with codecs, other 'C2xx devices, and external peripherals. The SSP offers:

- Two four-word-deep first in, first out (FIFO) buffers that have interrupt-generating capabilities.
- Burst and continuous transfer modes.
- A wide range of operation speeds when external clocking is used.

If internal clocking is used, the speed is fixed at 1/2 of the internal DSP clock frequency. For more information on the SSP, see Chapter 9.

Asynchronous serial port (ASP)

The 'C2xx asynchronous serial port (ASP) communicates with asynchronous serial devices. The ASP has a maximum transfer rate of 250,000 characters per second (assuming it uses 10 bits to transmit each 8-bit character). The ASP also has logic for automatic baud detection, which allows the ASP to lock to the incoming data rate. All transfers through the asynchronous serial port use double buffering. See Chapter 10, *Asynchronous Serial Port*, for more information.

2.6 Scanning-Logic Circuitry

The 'C2xx has JTAG scanning-logic circuitry that is compatible with IEEE Standard 1149.1. This circuitry is used for emulation and testing purposes only. The serial scan path is used to test pin-to-pin continuity as well as to perform operational tests on the on-chip peripherals. The internal scanning logic provides access to all of the on-chip resources. Thus, the serial-scan pins and the emulation pins on 'C2xx devices allow on-board emulation. However, on all 'C2xx devices, the serial scan path does not have boundary scan logic. Appendix E provides information to help you meet the design requirements of the Texas Instruments XDS510™ emulator with respect to IEEE-1149.1 designs and discusses the XDS510 cable.

Central Processing Unit

This chapter describes the main components of the central processing unit (CPU). First, this chapter describes three fundamental sections of the CPU (see Figure 3–1):

- Input scaling section
- Multiplication section
- Central arithmetic logic section

The chapter then describes the auxiliary register arithmetic unit (ARAU), which performs arithmetic operations independently of the central arithmetic logic section. The chapter concludes with a description of status registers ST0 and ST1, which contain bits for determining processor modes, addressing pointer values, and indicating various processor conditions and arithmetic logic results.

Topic	Page
3.1 Input Scaling Section	3-3
3.2 Multiplication Section	3-5
3.3 Central Arithmetic Logic Section	3-8
3.4 Auxiliary Register Arithmetic Unit (ARAU)	3-12
3.5 Status Registers ST0 and ST1	3-15

Figure 3-1. Block Diagram of the Input Scaling, Central Arithmetic Logic, and Multiplication Sections of the CPU

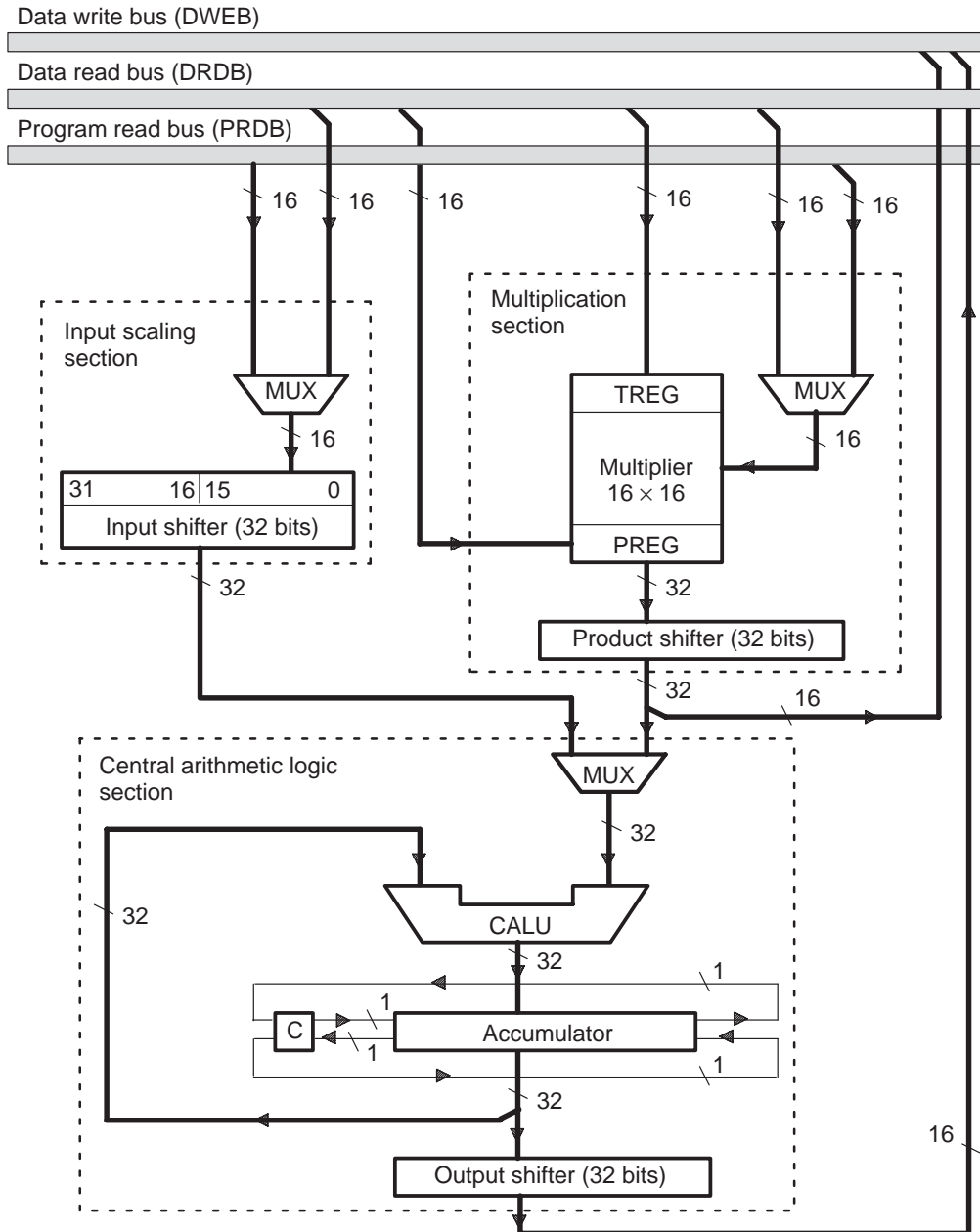

3.1 Input Scaling Section

A 32-bit input data-scaling shifter (input shifter) aligns a 16-bit value coming from memory to the 32-bit CALU. This data alignment is necessary for data-scaling arithmetic as well as aligning masks for logical operations. The input shifter operates as part of the data path between program or data space and the CALU and, thus, requires no cycle overhead. Described directly below are the input, the output, and the shift count of the input shifter. Throughout the discussion, refer to Figure 3–2.

Figure 3–2. Block Diagram of the Input Scaling Section

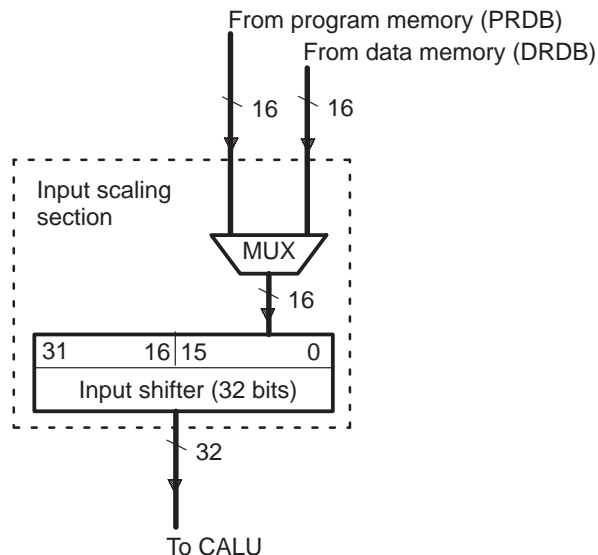

Input. Bits 15 through 0 of the input shifter accept a 16-bit input from either of two sources (see Figure 3–2):

- The data read bus (DRDB).* This input is a value from a data memory location referenced in an instruction operand.
- The program read bus (PRDB).* This input is a constant value given as an instruction operand.

Output. After a value has been accepted into bits 15 through 0, the input shifter aligns the 16-bit value to the 32-bit bus of the CALU as shown in Figure 3–2. The shifter shifts the value left 0 to 16 bits and then sends the 32-bit result to the CALU.

During the left shift, unused LSBs in the shifter are filled with zeros, and unused MSBs in the shifter are either filled with zeros or sign extended, depending on the value of the sign-extension mode bit (SXM) of status register ST1.

Shift count. The shifter can left-shift a 16-bit value by 0 to 16 bits. The size of the shift (or the shift count) is obtained from one of two sources:

- ❑ *A constant embedded in the instruction word.* Putting the shift count in the instruction word allows you to use specific data-scaling or alignment operations customized for your program code.
- ❑ *The four LSBs of the temporary register (TREG).* The TREG-based shift allows the data-scaling factor to be determined dynamically so that it can be adapted to the system's performance.

Sign-extension mode bit. For many but not all instructions, the sign-extension mode bit (SXM), bit 10 of status register ST1, determines whether the CALU uses sign extension during its calculations. If SXM = 0, sign extension is suppressed. If SXM = 1, the output of the input shifter is sign extended. Figure 3–3 shows an example of an input value shifted left by 8 bits for SXM = 0. The MSBs of the value passed to the CALU are zero filled. Figure 3–4 shows the same shift but with SXM = 1. The value is sign extended during the shift.

Figure 3–3. Operation of the Input Shifter for SXM = 0

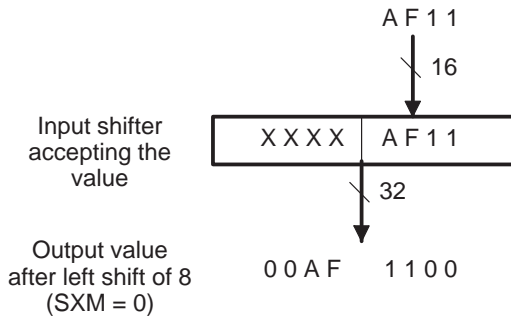
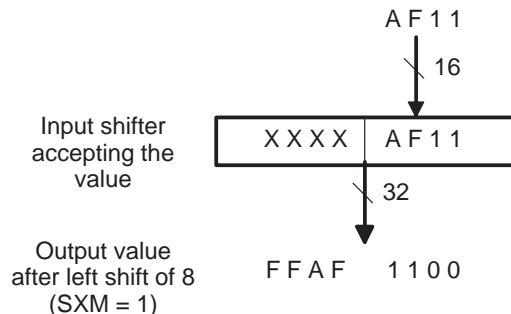

Figure 3–4. Operation of the Input Shifter for SXM = 1



3.2 Multiplication Section

The 'C2xx uses a 16-bit \times 16-bit hardware multiplier that can produce a signed or unsigned 32-bit product in a single machine cycle. As shown in Figure 3–5, the multiplication section consists of:

- ❑ The 16-bit temporary register (TREG), which holds one of the multipliers
- ❑ The multiplier, which multiplies the TREG value by a second value from data memory or program memory
- ❑ The 32-bit product register (PREG), which receives the result of the multiplication
- ❑ The product shifter, which scales the PREG value before passing it to the CALU.

Figure 3–5. Block Diagram of the Multiplication Section

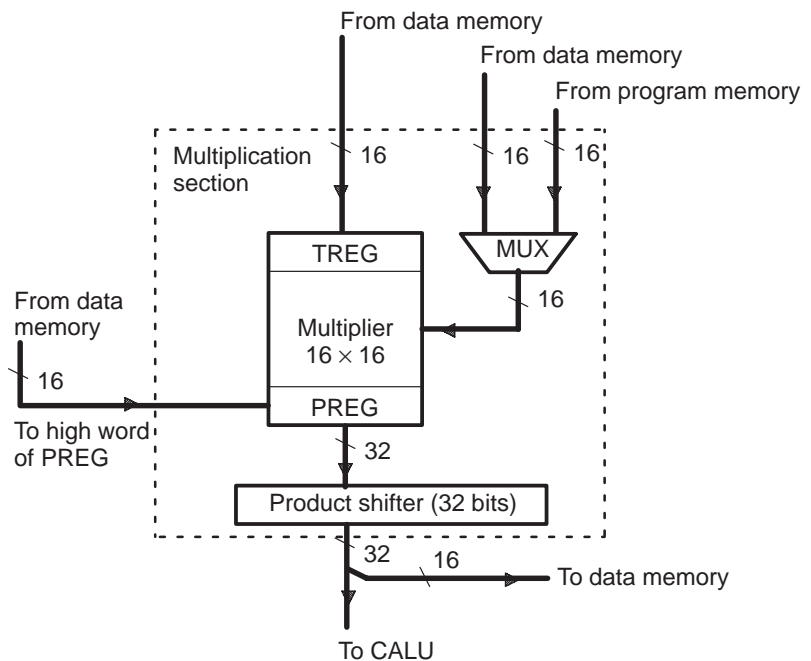

3.2.1 Multiplier

The 16-bit \times 16-bit hardware multiplier can produce a signed or unsigned 32-bit product in a single machine cycle. The two numbers being multiplied are treated as 2s-complement numbers, except during unsigned multiplication (MPYU instruction). Descriptions of the inputs and output of the multiplier follow.

Inputs. The multiplier accepts two 16-bit inputs:

- One input is always from the 16-bit temporary register (TREG). The TREG is loaded before the multiplication with a data-value from the data read bus (DRDB).
- The other input is one of the following:
 - A data-memory value from the data read bus (DRDB).
 - A program memory value from the program read bus (PRDB).

Output. After the two 16-bit inputs are multiplied, the 32-bit result is stored in the product register (PREG). The output of the PREG is connected to the 32-bit product-scaling shifter. Through this shifter, the product may be transferred from the PREG to the CALU or to data memory (by the SPH and SPL instructions).

3.2.2 Product-Scaling Shifter

The product-scaling shifter (product shifter) facilitates scaling of the product register (PREG) value. The shifter has a 32-bit input connected to the output of the PREG and a 32-bit output connected to the input of the CALU.

Input. The shifter has a 32-bit input connected to the output of the PREG.

Output. After the shifter completes the shift, all 32 bits of the result can be passed to the CALU, or 16 bits of the result can be stored to data memory.

Shift Modes. This shifter uses one of four product shift modes, summarized in Table 3–1. As shown in the table, these modes are determined by the product shift mode (PM) bits of status register ST1. In the first shift mode (PM = 00), the shifter does not shift the product at all before giving it to the CALU or to data memory. The next two modes cause left shifts (of one or four), which are useful for implementing fractional arithmetic or justifying products. The right-shift mode shifts the product by six bits, enabling the execution of up to 128 consecutive multiply-and-accumulate operations without causing the accumulator to overflow. Note that the content of the PREG remains unchanged; the value is copied to the product shifter and shifted there.

Note:

The right shift in the product shifter is always sign extended, regardless of the value of the sign-extension mode bit (SXM) of status register ST1.

Table 3–1. Product Shift Modes for the Product-Scaling Shifter

PM	Shift	Comments
00	no shift	Product sent to CALU or data write bus (DWEB) with no shift
01	left 1	Removes the extra sign bit generated in a 2s-complement multiply to produce a Q31 product [†]
10	left 4	Removes the extra four sign bits generated in a 16-bit × 13-bit 2s-complement multiply to produce a Q31 product [†] when multiplying by a 13-bit constant
11	right 6	Scales the product to allow up to 128 product accumulations without overflowing the accumulator. The right shift is always sign extended, regardless of the value of the sign-extension mode bit (SXM) of status register ST1.

[†] A Q31 number is a binary fraction in which there are 31 digits to the right of the binary point (the base 2 equivalent of the base 10 decimal point).

3.3 Central Arithmetic Logic Section

Figure 3–6 shows the main components of the central arithmetic logic section, which are:

- ❑ The central arithmetic logic unit (CALU), which implements a wide range of arithmetic and logic functions.
- ❑ The 32-bit accumulator (ACC), which receives the output of the CALU and is capable of performing bit shifts on its contents with the help of the carry bit (C). Figure 3–6 shows the accumulator’s high word (ACCH) and low word (ACCL).
- ❑ The output shifter, which can shift a copy of either the high word or low word of the accumulator before sending it to data memory for storage.

Figure 3–6. Block Diagram of the Central Arithmetic Logic Section

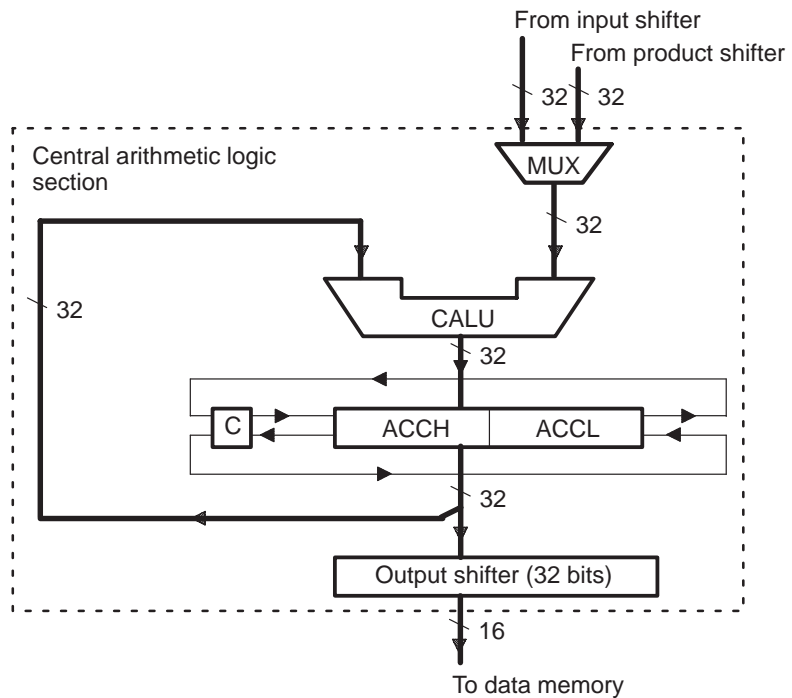

3.3.1 Central Arithmetic Logic Unit (CALU)

The central arithmetic logic unit (CALU), implements a wide range of arithmetic and logic functions, most of which execute in a single clock cycle. These functions can be grouped into four categories:

- 16-bit addition
- 16-bit subtraction
- Boolean logic operations
- Bit testing, shifting, and rotating.

Because the CALU can perform Boolean operations, you can perform bit manipulation. For bit shifting and rotating, the CALU uses the accumulator. The CALU is referred to as central because there is an independent arithmetic unit, the auxiliary register arithmetic unit (ARAU), which is described in Section 3.4. A description of the inputs, the output, and an associated status bit of the CALU follows.

Inputs. The CALU has two inputs (see again Figure 3–6):

- One input is always provided by the 32-bit accumulator.
- The other input is provided by one of the following:
 - The product-scaling shifter (see subsection 3.2.2)
 - The input data-scaling shifter (see Section 3.1)

Output. Once the CALU performs an operation, it transfers the result to the 32-bit accumulator, which is capable of performing bit shifts of its contents. The output of the accumulator is connected to the 32-bit output data-scaling shifter. Through the output shifter, the accumulator's upper and lower 16-bit words can be individually shifted and stored to data memory.

Sign-extension mode bit. For many but not all instructions, the sign-extension mode bit (SXM), bit 10 of status register ST1, determines whether the CALU uses sign extension during its calculations. If $SXM = 0$, sign extension is suppressed. If $SXM = 1$, sign extension is enabled.

3.3.2 Accumulator

Once the CALU performs an operation, it transfers the result to the 32-bit accumulator, which can then perform single-bit shifts or rotations on its contents. Each of the accumulator's upper and lower 16-bit words can be passed to the output data-scaling shifter, where it can be shifted, and then stored in data memory. Status bits and branch instructions associated with the accumulator are discussed directly below.

Status bits. Four status bits are associated with the accumulator:

- Carry bit (C).** C (bit 9 of status register ST1) is affected during:
 - Additions to and subtractions from the accumulator:
 - C = 0 When the result of a subtraction generates a borrow.
When the result of an addition does not generate a carry. (Exception: When the ADD instruction is used with a shift of 16 and no carry is generated, the ADD instruction has no effect on C.)
 - C = 1 When the result of an addition generates a carry.
When the result of a subtraction does not generate a borrow. (Exception: When the SUB instruction is used with a shift of 16 and no borrow is generated, the SUB instruction has no effect on C.)
 - Single-bit shifts and rotations of the accumulator value. During a left shift or rotation, the most significant bit of the accumulator is passed to C; during a right shift or rotation, the least significant bit is passed to C.
- Overflow mode bit (OVM).** OVM (bit 11 of status register ST0) determines how the accumulator will reflect arithmetic overflows. When the processor is in overflow mode (OVM = 1) and an overflow occurs, the accumulator is filled with one of two specific values:
 - If the overflow is in the positive direction, the accumulator is filled with its most positive value (7FFF FFFFh).
 - If the overflow is in the negative direction, the accumulator is filled with its most negative value (8000 0000h).
- Overflow flag bit (OV).** OV is bit 12 of status register ST0. When no accumulator overflow is detected, OV is latched at 0. When overflow (positive or negative) occurs, OV is set to 1 and latched.
- Test/control flag bit (TC).** TC (bit 11 of status register ST1) is set to 0 or 1 depending on the value of a tested bit. In the case of the NORM instruction, if the exclusive-OR of the two MSBs of the accumulator is true, TC is set to 1.

A number of branch instructions are implemented based on the status of bits C, OV, and TC, and on the value in the accumulator (as compared to zero). For more information about these instructions, see Section 5.4, *Conditional Branches, Calls, and Returns*, on page 5-10.

3.3.3 Output Data-Scaling Shifter

The output data-scaling shifter (output shifter) has a 32-bit input connected to the 32-bit output of the accumulator and a 16-bit output connected to the data bus. The shifter copies all 32-bits of the accumulator and then performs a left shift on its content; it can be shifted from zero to seven bits, as specified in the corresponding store instruction. The upper word (SACH instruction) or lower word (SACL instruction) of the shifter is then stored to data memory. The content of the accumulator remains unchanged.

When the output shifter performs the shift, the MSBs are lost and the LSBs are zero filled. Figure 3–7 shows an example in which the accumulator value is shifted left by four bits and the shifted high word is stored to data memory. Figure 3–8 shows the same accumulator value shifted left by 6 bits and then the shifted low word stored.

Figure 3–7. Shifting and Storing the High Word of the Accumulator

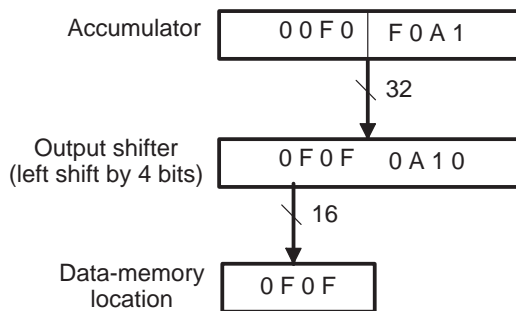
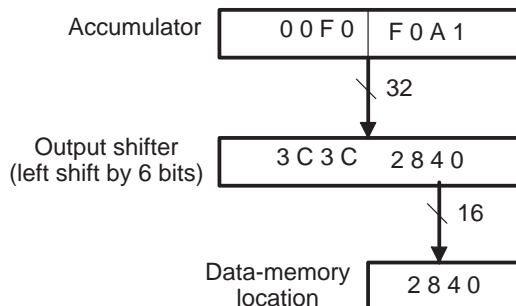

Figure 3–8. Shifting and Storing the Low Word of the Accumulator



3.4 Auxiliary Register Arithmetic Unit (ARAU)

The CPU also contains the auxiliary register arithmetic unit (ARAU), an arithmetic unit independent of the central arithmetic logic unit (CALU). The main function of the ARAU is to perform arithmetic operations on eight auxiliary registers (AR7 through AR0) in parallel with operations occurring in the CALU. Figure 3–9 shows the ARAU and related logic.

Figure 3–9. ARAU and Related Logic

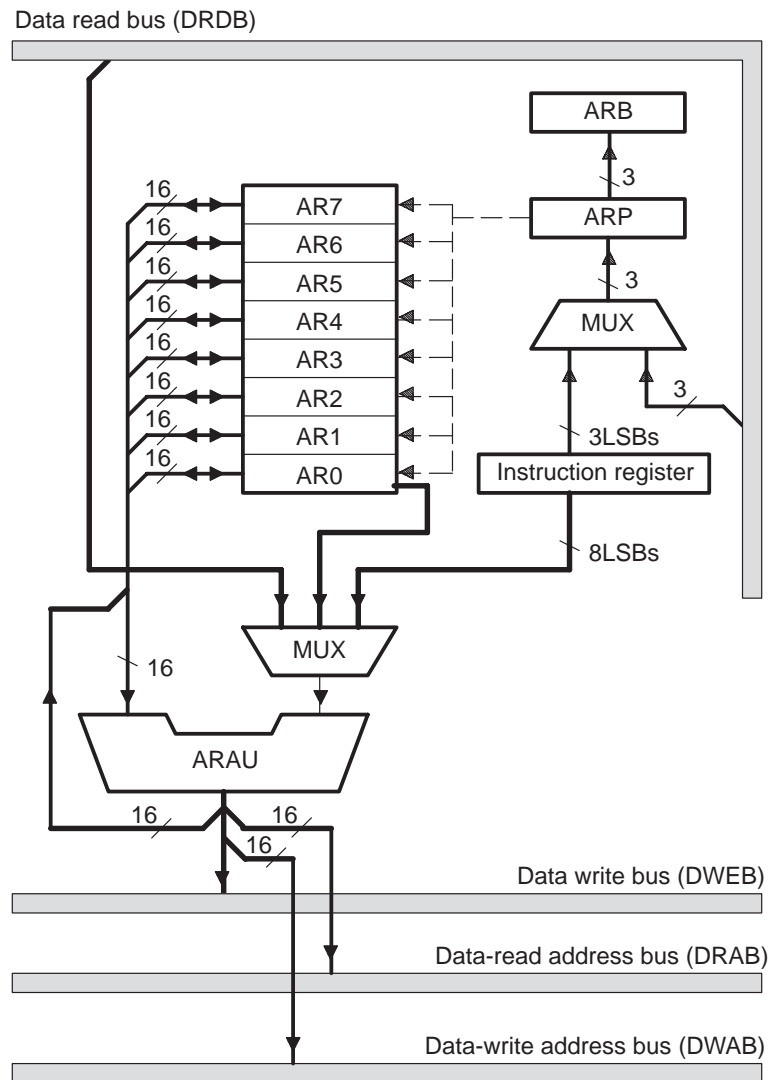

The eight auxiliary registers (AR7–AR0) provide flexible and powerful indirect addressing. Any location in the 64K data memory space can be accessed using a 16-bit address contained in an auxiliary register. For the details of indirect addressing, see Section 6.3 on page 6-9.

To select a specific auxiliary register, load the 3-bit auxiliary register pointer (ARP) of status register ST0 with a value from 0 through 7. The ARP can be loaded as a primary operation by the MAR instruction (which only performs modifications to the auxiliary registers and the ARP) or by the LST instruction (which can load a data-memory value to ST0 by way of the data read bus, DRDB). The ARP can be loaded as a secondary operation by any instruction that supports indirect addressing.

The register pointed to by the ARP is referred to as the *current auxiliary register* or *current AR*. During the processing of an instruction, the content of the current auxiliary register is used as the address at which the data-memory access will take place. The ARAU passes this address to the data-read address bus (DRAB) if the instruction requires a read from data memory, or it passes the address to the data-write address bus (DWAB) if the instruction requires a write to data memory. After the instruction uses the data value, the contents of the current auxiliary register can be incremented or decremented by the ARAU, which implements unsigned 16-bit arithmetic.

3.4.1 ARAU and Auxiliary Register Functions

The ARAU performs the following operations:

- Increments or decrements an auxiliary register value by 1 or by an index amount (by way of any instruction that supports indirect addressing)
- Adds a constant value to an auxiliary register value (ADRK instruction) or subtracts a constant value from an auxiliary register value (SBRK instruction). The constant is an 8-bit value taken from the eight LSBs of the instruction word.
- Compares the content of AR0 with the content of the current AR and puts the result in the test/control flag bit (TC) of status register ST1 (CMPR instruction). The result is passed to TC by way of the data write bus (DWEB).

Normally, the ARAU performs its arithmetic operations in the decode phase of the pipeline (when the instruction specifying the operations is being decoded). This allows the address to be generated before the decode phase of the next instruction. There is an exception to this rule: During processing of the NORM instruction, the auxiliary register and/or ARP modification is done during the

execute phase of the pipeline. For information on the operation of the pipeline, see Section 5.2 on page 5-7.

In addition to using the auxiliary registers to reference data-memory addresses, you can use them for other purposes. For example, you can:

- Use the auxiliary registers to support conditional branches, calls, and returns by using the CMPR instruction. This instruction compares the content of AR0 with the content of the current AR and puts the result in the test/control flag bit (TC) of status register ST1.
- Use the auxiliary registers for temporary storage by using the LAR instruction to load values into the registers and the SAR instruction to store AR values to data memory.
- Use the auxiliary registers as software counters, incrementing or decrementing them as necessary.

3.5 Status Registers ST0 and ST1

The 'C2xx has two status registers, ST0 and ST1, which contain status and control bits. These registers can be stored into and loaded from data memory, thus allowing the status of the machine to be saved and restored for subroutines.

The LST (load status register) instruction writes to ST0 and ST1, and the SST (store status register) instruction reads from ST0 and ST1 (with the exception of the INTM bit, which is not affected by the LST instruction). Many of the individual bits of these registers can be set and cleared using the SETC and CLRC instructions. For example, the sign-extension mode is set with SETC SXM and cleared with CLRC SXM.

Figure 3–10 and Figure 3–11 show the organization of status registers ST0 and ST1, respectively. Several bits in the status registers are reserved; they are always read as logic 1s. The other bits are described in alphabetical order in Table 3–2.

Figure 3–10. Status Register ST0

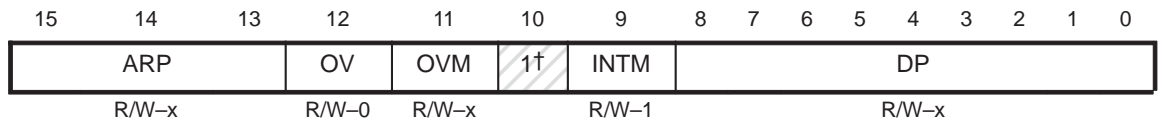

Note: R = Read access; W = Write access; value following dash (–) is value after reset (x means value not affected by reset).

† This reserved bit is always read as 1. Writes have no effect on it.

Figure 3–11. Status Register ST1

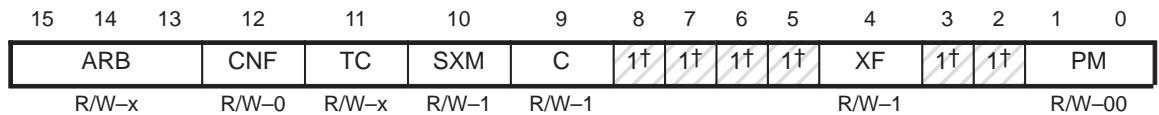

Note: R = Read access; W = Write access; value following dash (–) is value after reset (x means value not affected by reset).

† These reserved bits are always read as 1s. Writes have no effect on them.

Table 3–2. Bit Fields of Status Registers ST0 and ST1

Name	Description
ARB	Auxiliary register pointer buffer. Whenever the auxiliary register pointer (ARP) is loaded, the previous ARP value is copied to the ARB, except during an LST (load status register) instruction. When the ARB is loaded by an LST instruction, the same value is also copied to the ARP.
ARP	Auxiliary register pointer. This 3-bit field selects which auxiliary register (AR) to use in indirect addressing. When the ARP is loaded, the previous ARP value is copied to the ARB register, except during an LST (load status register) instruction. The ARP may be modified by memory-reference instructions using indirect addressing, and by the MAR (modify auxiliary register) and LST instructions. When the ARB is loaded by an LST instruction, the same value is also copied to the ARP. For more details on the use of ARP in indirect addressing, see Section 6.3, <i>Indirect Addressing Mode</i> , on page 6-9.
C	Carry bit. This bit is set to 1 if the result of an addition generates a carry, or cleared to 0 if the result of a subtraction generates a borrow. Otherwise, it is cleared after an addition or set after a subtraction, except if the instruction is ADD or SUB with a 16-bit shift. In these cases, ADD can only set and SUB only clear the carry bit, but cannot affect it otherwise. The single-bit shift and rotate instructions also affect this bit, as well as the SETC, CLRC, and LST instructions. The conditional branch, call, and return instructions can execute based on the status of C. C is set to 1 on reset.
CNF	On-chip DARAM configuration bit. This bit determines whether reconfigurable dual-access RAM blocks are mapped to data space or to program space. The CNF bit may be modified by the SETC CNF, CLRC CNF, and LST instructions. Reset clears the CNF bit to 0. For more information about CNF and the dual-access RAM blocks, see Chapter 4, <i>Memory and I/O Spaces</i> .
	CNF = 0 Reconfigurable dual-access RAM blocks are mapped to data space.
	CNF = 1 Reconfigurable dual-access RAM blocks are mapped to program space.
DP	Data page pointer. When an instruction uses direct addressing, the 9-bit DP field is concatenated with the 7 LSBs of the instruction word to form a full 16-bit data-memory address. For more details, see Section 6.2, <i>Direct Addressing Mode</i> , on page 6-4. The LST and LDP (load DP) instructions can modify the DP field.
INTM	Interrupt mode bit. This bit enables or disables all maskable interrupts. INTM is set and cleared by the SETC <u>INTM</u> and CLRC <u>INTM</u> instructions, respectively. INTM has no effect on the nonmaskable interrupts <u>RS</u> and <u>NMI</u> or on interrupts initiated by software. INTM is unaffected by the LST (load status register) instruction. INTM is set to 1 when an interrupt trap is taken (except in the case of the TRAP instruction) and at reset.
	INTM = 0 All unmasked interrupts are enabled.
	INTM = 1 All maskable interrupts are disabled.
OV	Overflow flag bit. This bit holds a latched value that indicates whether overflow has occurred in the CALU. OV is set to 1 when an overflow occurs in the CALU. Once an overflow occurs, the OV bit remains set until it is cleared by a reset, a conditional branch on overflow (OV) or no overflow (NOV), or an LST instruction .

Table 3–2. Bit Fields of Status Registers ST0 and ST1 (Continued)

Name	Description
OVM	<p>Overflow mode bit. OVM determines how overflows in the CALU are handled. The SETC and CLRC instructions set and clear this bit, respectively. An LST instruction can also be used to modify OVM.</p> <p>OVM = 0 Results overflow normally in the accumulator.</p> <p>OVM = 1 The accumulator is set to either its most positive or negative value upon encountering an overflow. (See subsection 3.3.2, <i>Accumulator</i>.)</p>
PM	<p>Product shift mode. PM determines the amount that the PREG value is shifted on its way to the CALU or to data memory. Note that the content of the PREG remains unchanged; the value is copied to the product shifter and shifted there. PM is loaded by the SPM and LST instructions. The PM bits are cleared by reset.</p> <p>PM = 00 The multiplier's 32-bit product is passed to the CALU or to data memory with no shift.</p> <p>PM = 01 The output of the PREG is left shifted one place (with the LSBs zero filled) before being passed to the CALU or to data memory.</p> <p>PM = 10 The output of the PREG is left shifted four bits (with the LSBs zero filled) before being passed to the CALU or to data memory.</p> <p>PM = 11 This mode produces a right shift of six bits, sign extended.</p>
SXM	<p>Sign-extension mode bit. SXM does not affect the basic operation of certain instructions. For example, the ADDS instruction suppresses sign extension regardless of SXM. This bit is set by the SETC SXM instruction and cleared by the CLRC SXM instruction, and may be loaded by the LST instruction. SXM is set to 1 by reset.</p> <p>SXM = 0 This mode suppresses sign extension.</p> <p>SXM = 1 This mode produces sign extension on data as it is passed into the accumulator from the input shifter.</p>
TC	<p>Test/control flag bit. The TC bit is set to 1 if a bit tested by BIT or BITT is a 1, if a compare condition tested by CMPR exists between the current auxiliary register and AR0, or if the exclusive-OR function of the two MSBs of the accumulator is true when tested by a NORM instruction. The conditional branch, call, and return instructions can execute based on the condition of the TC bit. The TC bit is affected by the BIT, BITT, CMPR, LST, and NORM instructions.</p>
XF	<p>XF pin status bit. This bit determines the state of the XF pin, which is a general-purpose output pin. XF is set by the SETC XF instruction and cleared by the CLRC XF instruction. XF can also be modified with an LST instruction. XF is set to 1 by reset.</p>

Memory and I/O Spaces

This chapter describes the 'C2xx memory configuration options and the address maps of the individual 'C2xx devices. It also illustrates typical ways of interfacing the 'C2xx with external memory and external input/output (I/O) devices.

Each 'C2xx device has a 16-bit address line that accesses four individually selectable spaces (224K words total):

- A 64K-word program space
- A 64K-word local data space
- A 32K-word global data space
- A 64K-word I/O space

Also available on select 'C2xx devices are an on-chip boot loader and a HOLD operation. The on-chip boot loader allows a 'C2xx to boot software from an 8-bit external ROM to a 16-bit external RAM at reset. The HOLD operation allows a 'C2xx to give external devices direct memory access to external program, data, and I/O spaces.

Topic	Page
4.1 Overview of the Memory and I/O Spaces	4-2
4.2 Program Memory	4-5
4.3 Local Data Memory	4-7
4.4 Global Data Memory	4-11
4.5 Boot Loader	4-14
4.6 I/O Space	4-23
4.7 Direct Memory Access Using the HOLD Operation	4-27
4.8 Device-Specific Information	4-31

4.1 Overview of the Memory and I/O Spaces

The 'C2xx address map is organized into four individually selectable spaces:

- Program memory** (64K words) contains the instructions to be executed, as well as data used during program execution.
- Local data memory** (64K words) holds data used by the instructions.
- Global data memory** (32K words) shares data with other processors or serves as additional data space. Addresses in the upper 32K words (8000h–FFFFh) of local data memory can be used for global data memory.
- Input/output (I/O) space** (64K words) interfaces to external peripherals and contains registers for the on-chip peripherals.

These spaces provide a total address range of 224K words. The 'C2xx includes a considerable amount of on-chip memory to aid in system performance and integration and a considerable amount of addresses that can be used for external memory and I/O devices.

The advantages of operating from on-chip memory are:

- Higher performance than external memory (because the wait states required for slower external memories are avoided)
- Lower cost than external memory
- Lower power consumption than external memory

The advantage of operating from external memory is the ability to access a larger address space.

The 'C2xx design is based on an enhanced Harvard architecture. The 'C2xx memory spaces are accessible on three parallel buses—the program address bus (PAB), the data-read address bus (DRAB), and the data-write address bus (DWAB). Because the operations of the three buses are independent, it is possible to access both the program and data spaces simultaneously. Within a given machine cycle, the central arithmetic logic unit (CALU) can execute as many as three concurrent memory operations.

4.1.1 Pins for Interfacing to External Memory and I/O Spaces

The pins for interfacing to external memory and I/O space, described in Table 4–1, are of four main types:

- **External buses.** Sixteen signals (A15–A0) are available for passing an address from the 'C2xx to another device. Sixteen signals (D15–D0) are available for transferring a data value between the 'C2xx and another device.
- **Select signals.** These signals can be used by external devices to determine when the 'C2xx is requesting access to off-chip locations, and whether that request is for data, program, global, or I/O space.
- **Read/write signals.** These signals indicate to external devices the direction of a data transfer (to the 'C2xx or from the 'C2xx).
- **Request/control signals.** The input request signals ($\overline{\text{BOOT}}$, $\overline{\text{MP/MC}}$, $\overline{\text{RAMEN}}$, $\overline{\text{READY}}$, and $\overline{\text{HOLD}}$) effect a change in the operation of the 'C2xx. The output $\overline{\text{HOLDA}}$ is the response to $\overline{\text{HOLD}}$.

Table 4–1. Pins for Interfacing With External Memory and I/O Spaces

	Pin(s)	Description
External buses	A15–A0	The 16 lines of the external address bus. This bus can address up to 64K words of external memory or I/O space.
	D15–D0	The 16 bidirectional lines of the external data bus. This bus carries data to and from external memory or I/O space.
Select signals	$\overline{\text{DS}}$	Data memory select pin. The 'C2xx asserts $\overline{\text{DS}}$ to indicate an access to external data memory (local or global).
	$\overline{\text{BR}}$	Bus request pin. The 'C2xx asserts both $\overline{\text{BR}}$ and $\overline{\text{DS}}$ to indicate an access to global data memory.
	$\overline{\text{PS}}$	Program memory select pin. The 'C2xx asserts $\overline{\text{PS}}$ to indicate an access to external program memory.
	$\overline{\text{IS}}$	I/O space select pin. The 'C2xx asserts $\overline{\text{IS}}$ to indicate an access to external I/O space.
	$\overline{\text{STRB}}$	External access active strobe. The 'C2xx asserts $\overline{\text{STRB}}$ during accesses to external program, data, or I/O space.

Table 4–1. Pins for Interfacing With External Memory and I/O Spaces (Continued)

	Pin(s)	Description
Read/write signals	$\overline{R/W}$	Read/write pin. This pin indicates the direction of transfer between the 'C2xx and external program, data, or I/O space.
	\overline{RD}	Read select pin. The 'C2xx asserts \overline{RD} to request a read from external program, data, or I/O space.
	\overline{WE}	Write enable pin. The 'C2xx asserts \overline{WE} to request a write to external program, data, or I/O space.
Request/control signals	\overline{BOOT}	Boot load pin. This pin is only on devices that have the on-chip boot loader. If \overline{BOOT} is low during a hardware reset, the 'C2xx transfers code from EPROM in global data memory to RAM in external program memory.
	MP/\overline{MC}	Microprocessor/microcomputer pin. This pin is only on devices with on-chip non-volatile program memory. The level on this pin is tested at reset. If MP/\overline{MC} is high, the device is in microprocessor mode (the reset vector is fetched from external memory). If MP/\overline{MC} is low, the device is in microcomputer mode (the reset vector is fetched from on-chip memory).
	\overline{RAMEN}	Single-access RAM enable pin. On 'C2xx devices with on-chip single-access RAM, when this pin is high, the RAM is enabled; when this pin is low, the RAM is disabled.
	\overline{READY}	External device ready pin (for generating wait states externally). When this pin is driven low, the 'C2xx waits one CPU cycle and then tests \overline{READY} again. After \overline{READY} is driven low, the 'C2xx does not continue processing until \overline{READY} is driven high. If \overline{READY} is not used, it should be kept high. On the 'C203, at boot time, this pin must be high.
	\overline{HOLD}	HOLD operation request pin. An external device can request control of the external buses by asserting \overline{HOLD} . After the 'C2xx (along with proper software logic) asserts \overline{HOLDA} , the external device controls the buses until it deasserts \overline{HOLD} .
	\overline{HOLDA}	\overline{HOLD} acknowledge pin. The 'C2xx (with assistance from proper program code) asserts \overline{HOLDA} to acknowledge that \overline{HOLD} has been asserted and places its external buses in high impedance.

4.2 Program Memory

Program-memory space holds the code for applications; it can also hold table information and constant operands. The program-memory space addresses up to 64K 16-bit words. Every 'C2xx device contains a DARAM block B0 that can be configured as program memory or data memory. Other on-chip program memory may be SARAM and ROM or flash memory. For information on configuring on-chip program-memory blocks, see Section 4.8.

4.2.1 Interfacing With External Program Memory

The 'C2xx can address up to 64K words of external program memory. While the 'C2xx is accessing the on-chip program-memory blocks, the external memory signals \overline{PS} and \overline{STRB} are in high impedance. The external buses are active only when the 'C2xx is accessing locations within the address ranges mapped to external memory. An active \overline{PS} signal indicates that the external buses are being used for program memory. Whenever the external buses are active (when external memory or I/O space is being accessed) the 'C2xx drives the \overline{STRB} signal low.

For fast memory interfacing, it is important to select external memory with fast access time. If fast memory is not available, or if speed is not a serious consideration, you can use the READY signal and/or the on-chip wait-state generator to create wait states.

Figure 4–1 shows an example of interfacing to external program memory. In the figure, $8K \times 16$ -bit static memory is interfaced to the 'C2xx using two $8K \times 8$ -bit RAMs.

Obtain the Proper Timing Information

When interfacing memory with high-speed 'C2xx devices, refer to the data sheet for that 'C2xx device for the required access, delay, and hold times.

Figure 4-1. Interface With External Program Memory

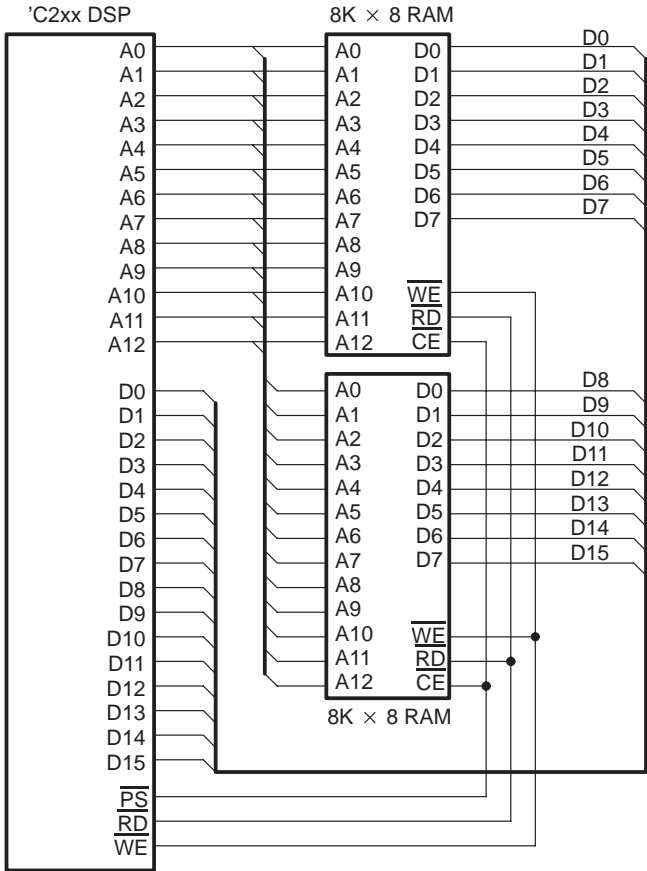

4.3 Local Data Memory

The local data-memory space addresses up to 64K 16-bit words. Every 'C2xx device has three on-chip DARAM blocks: B0, B1, and B2. Block B0 has 256 words that are configurable as either data locations or program locations. Blocks B1 (256 words) and B2 (32 words) have a total of 288 words that are available for data memory only. Some 'C2xx devices, in addition to the three DARAM blocks, have an on-chip SARAM block that can be used for program and/or data memory. Section 4.8 tells how to configure these memory blocks.

Data memory can be addressed with either of two addressing modes: direct-addressing mode or indirect-addressing mode. Addressing modes are described in detail in Chapter 6.

When direct addressing is used, data memory is addressed in blocks of 128 words called data pages. Figure 4–2 shows how these blocks are addressed. The entire 64K of data memory consists of 512 data pages labeled 0 through 511. The current data page is determined by the value in the 9-bit data page pointer (DP) in status register ST0. Each of the 128 words on the current page is referenced by a 7-bit offset, which is taken from the instruction that is using direct addressing. Therefore, when an instruction uses direct addressing, you must specify both the data page (with a preceding instruction) and the offset (in the instruction that accesses data memory).

Figure 4–2. Pages of Data Memory

DP value	Offset	'C2xx Data Memory
0000 0000 0	000 0000	Page 0: 0000h–007Fh
⋮	⋮	
0000 0000 0	111 1111	Page 1: 0080h–00FFh
0000 0000 1	000 0000	
⋮	⋮	Page 2: 0100h–017Fh
0000 0000 1	111 1111	
0000 0001 0	000 0000	Page 511: FF80h–FFFFh
⋮	⋮	
0000 0001 0	111 1111	
⋮	⋮	
⋮	⋮	
⋮	⋮	
⋮	⋮	
1111 1111 1	000 0000	Page 511: FF80h–FFFFh
⋮	⋮	
1111 1111 1	111 1111	

4.3.1 Data Page 0 Address Map

Table 4–2 shows the address map of data page 0 (addresses 0000h–007Fh). Note the following:

- Three memory-mapped registers can be accessed with zero wait states:
 - Interrupt mask register (IMR)
 - Global memory allocation register (GREG)
 - Interrupt flag register (IFR)
- The test/emulation reserved area is used by the test and emulation systems for special information transfers.

Do Not Write to Test/Emulation Addresses

Writing to the test/emulation addresses can cause the device to change its operational mode and, therefore, affect the operation of an application.

- The scratch-pad RAM block (B2) includes 32 words of DARAM that provide for variable storage without fragmenting the larger RAM blocks, whether internal or external. This RAM block supports dual-access operations and can be addressed with any data-memory addressing mode.

Table 4–2. Data Page 0 Address Map

Address	Name	Description
0000h–0003h	–	Reserved
0004h	IMR	Interrupt mask register
0005h	GREG	Global memory allocation register
0006h	IFR	Interrupt flag register
0023h–0027h	–	Reserved
002Bh–002Fh	–	Reserved for test/emulation
0060h–007Fh	B2	Scratch-pad RAM (DARAM B2)

4.3.2 Interfacing With External Local Data Memory

While the 'C2xx is accessing the on-chip local data-memory blocks, the external memory signals \overline{DS} and \overline{STRB} are in high impedance. The external buses are active only when the 'C2xx is accessing locations within the address ranges mapped to external memory. An active \overline{DS} signal indicates that the external buses are being used for data memory. Whenever the external buses are active (when external memory or I/O space is being accessed) the 'C2xx drives the \overline{STRB} signal low.

For fast memory interfacing, it is important to select external memory with fast access time. If fast memory is not available, or if speed is not a serious consideration, you can use the READY signal and/or the on-chip wait-state generator to create wait states.

Figure 4–3 shows an example of interfacing to external data memory. In the figure $8K \times 16$ -bit static memory is interfaced to the 'C2xx using two $8K \times 8$ -bit RAMs. The RAM devices must have fast access times if the internal instruction speed is to be maintained.

Obtain the Proper Timing Information

When interfacing memory with high-speed 'C2xx devices, refer to the data sheet for that 'C2xx device for the required access, delay, and hold times.

Figure 4-3. Interface With External Local Data Memory

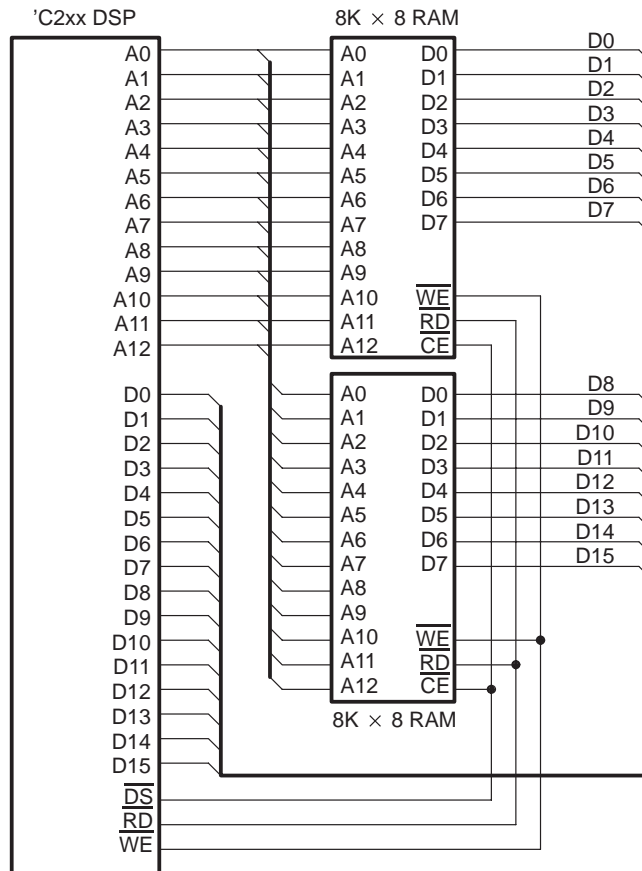

4.4 Global Data Memory

Addresses in the upper 32K words (8000h–FFFFh) of local data memory can be used for global data memory. The global memory allocation register (GREG) determines the size of the global data-memory space, which is between 256 and 32K words. The GREG is connected to the eight LSBs of the internal data bus and is memory-mapped to data-memory location 0005h. Table 4–3 shows the allowable GREG values and shows the corresponding address range set aside for global data memory. Any remaining addresses within 8000h–FFFFh are available for local data memory.

Note:

Choose only the GREG values listed in Table 4–3. Other values lead to fragmented memory maps.

Table 4–3. Global Data Memory Configurations

GREG Value		Local Memory		Global Memory	
High Byte	Low Byte	Range	Words	Range	Words
XXXX XXXX	0000 0000	0000h–FFFFh	65 536	–	0
XXXX XXXX	1000 0000	0000h–7FFFh	32 768	8000h–FFFFh	32 768
XXXX XXXX	1100 0000	0000h–BFFFh	49 152	C000h–FFFFh	16 384
XXXX XXXX	1110 0000	0000h–DFFFh	57 344	E000h–FFFFh	8 192
XXXX XXXX	1111 0000	0000h–EFFFh	61 440	F000h–FFFFh	4 096
XXXX XXXX	1111 1000	0000h–F7FFh	63 488	F800h–FFFFh	2 048
XXXX XXXX	1111 1100	0000h–FBFFh	64 512	FC00h–FFFFh	1 024
XXXX XXXX	1111 1110	0000h–FDFFh	65 024	FE00h–FFFFh	512
XXXX XXXX	1111 1111	0000h–FEFFh	65 280	FF00h–FFFFh	256

Note: X = Don't care

As an example of configuring global memory, suppose you want to designate 8K addresses as global addresses. You would write the 8-bit value 11100000_2 to the eight LSBs of the GREG (see Figure 4–4). This would designate addresses E000h–FFFFh of data memory as global data addresses (see Figure 4–5).

Figure 4–4. GREG Register Set to Configure 8K for Global Data Memory

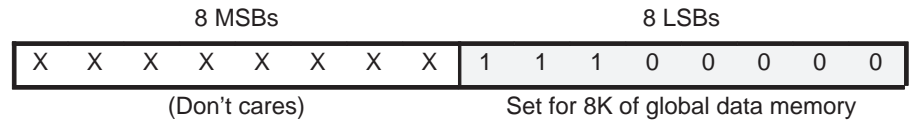
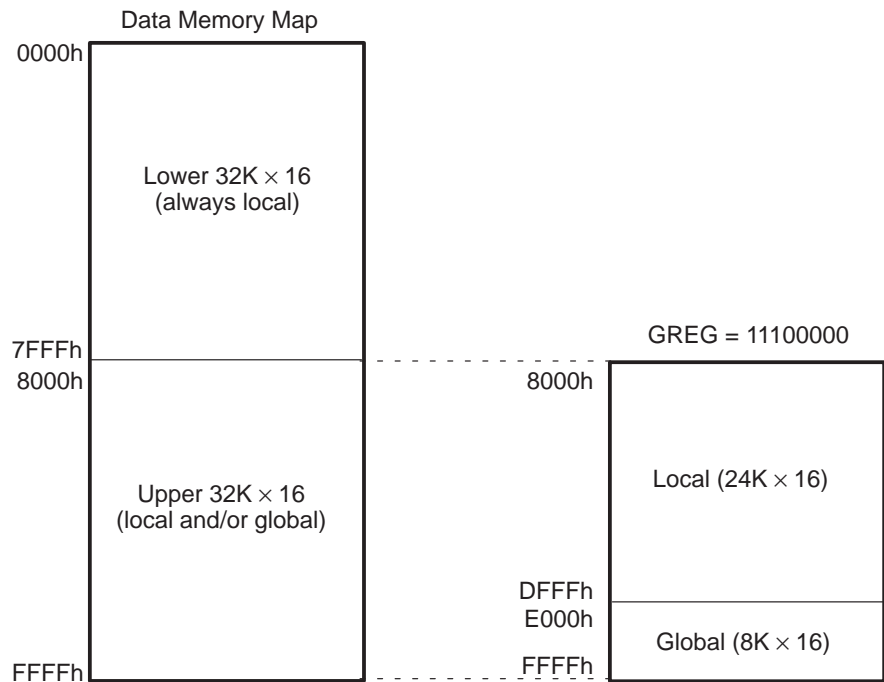

Figure 4–5. Global and Local Data Memory for GREG = 11100000



4.4.1 Interfacing With External Global Data Memory

When a program accesses any data-memory address, the 'C2xx drives the \overline{DS} signal low. If that address is within a range defined by the GREG as global, \overline{BR} and \overline{DS} are asserted. Because \overline{BR} differentiates local and global accesses, you can use the GREG to extend data memory by up to 32K. Figure 4–6 shows two external RAMs that are sharing data-memory addresses 8000h–FFFFh. Overlapping addresses must be reconfigured with the GREG in order to be

toggled between local memory and global memory. For example, in the system of Figure 4–6, when $GREG = \text{XXXXXXXX00000000}_2$ (no global memory), the local data RAM is fully accessible; when $GREG = \text{XXXXXXXX10000000}_2$ (all global memory), the local data RAM is not accessible.

Figure 4–6. Using 8000h–FFFFh for Local and Global External Memory

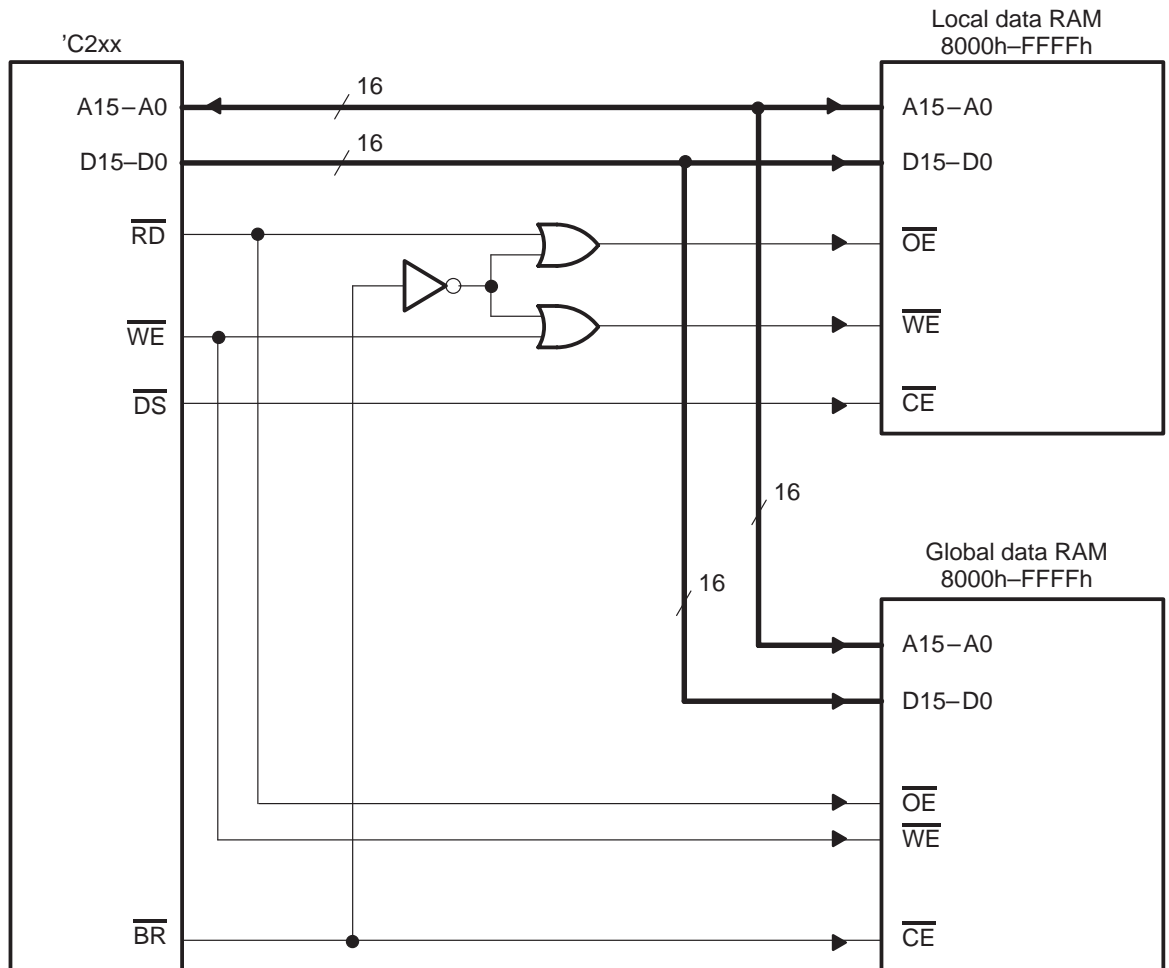

4.5 Boot Loader

This section applies to 'C2xx devices that have an on-chip boot loader. The boot loader is used for booting software from an 8-bit external ROM to a 16-bit external RAM at reset (see Figure 4–7). The source for your program is an external ROM located in external global data memory. The destination for the boot loaded program is RAM in program space. The main purpose of the boot loader is to provide you with the ability to use low-cost, simple-to-use 8-bit EPROMs with the 16-bit 'C2xx.

Figure 4–7. Simplified Block Diagram of Boot Loader Operation

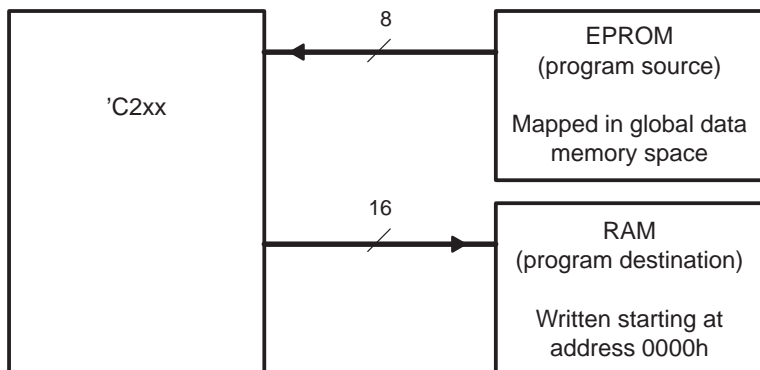

The code for the boot loader is stored on chip. Using the boot loader requires several steps: choosing an EPROM, connecting and programming the EPROM, enabling the boot loader program, and finally, booting.

4.5.1 Choosing an EPROM

The code that you want boot loaded must be stored in non-volatile external memory; usually, this code is stored in an EPROM. Most standard EPROMs can be used. At reset, the processor defaults to the maximum number of software wait states to accommodate slow EPROMs.

The maximum size for the EPROM is 32K words × 8 bits, which accommodates a program of up to 16K words × 16 bits. However, you could use the boot loader to load your own boot software to get around this limit or to perform a different type of boot.

Recommended EPROMs include the 27C32, 27C64, 27C128, and 27C256.

4.5.2 Connecting the EPROM to the Processor

To map the EPROM into the global data space at address 8000h, make the following connections between the processor and the EPROM (refer to Figure 4–8):

- Connect the address lines of the processor and the EPROM (see lines A14–A0 in the figure).
- Connect the data lines of the processor and the EPROM (see lines D7–D0 in the figure).
- Connect the processor's \overline{RD} pin to the EPROM's output enable pin (\overline{OE} in the figure).
- Connect the processor's \overline{BR} pin to the EPROM's chip enable pin (\overline{CE} in the figure).

Notes:

- 1) If the EPROM is smaller than 32K words \times 8 bits, connect only the address pins that are available on the EPROM.
- 2) When the boot loader accesses global memory, along with \overline{BR} , \overline{DS} is driven low. Design your system such that the \overline{DS} signal does not initiate undesired accesses to data memory during the boot loads.

Figure 4–8. Connecting the EPROM to the Processor

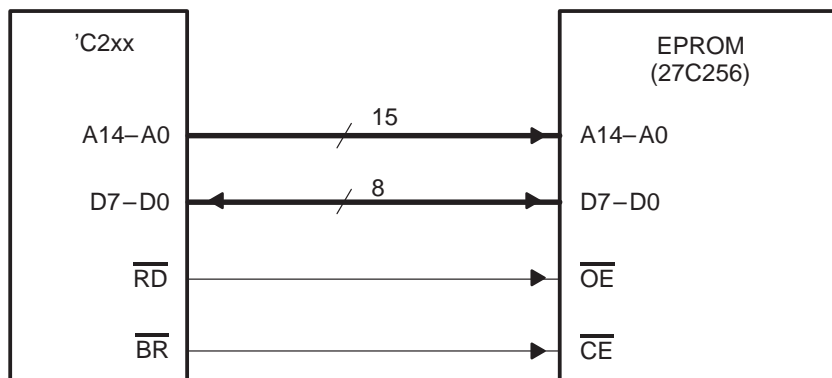

4.5.3 Programming the EPROM

Texas Instruments fixed-point development tools provide the utilities to generate the boot ROM code. (For an introduction to the procedure for generating boot loader code, see Appendix C, *Program Examples*.) However, should you need to do the programming, use the following procedure.

Store the following to the EPROM:

- Destination address.** Store the destination address in the first two bytes of the EPROM—store the high-order byte of the destination address at EPROM address 8000h and store the low-order byte at EPROM address 8001h.

- Program length.** Store N (the length of your program in bytes) in the next two bytes in EPROM. Use this calculation to determine N:

$$N = ((\text{number of bytes to be transferred})/2) - 1$$

Store the high-order N byte at EPROM address 8002h and the low-order N byte at EPROM address 8003h.

- Program.** Store the program, one byte at a time, beginning at EPROM address 8004h.

Each word in the program must be divided into two bytes in the EPROM; store the high-order byte first and store the low-order byte second. For example, if the first word were 813Fh, you would store 81h into the first byte (at 8004h) and 3Fh into the second byte (at 8005h). Then, you would store the high byte of the next word at address 8006h.

Notes:

- 1) Do not include the first four bytes of the EPROM in your calculation of the length (N). The boot loader uses N beginning at the fifth byte of the EPROM.
 - 2) Make sure the first part of the program on the EPROM contains code for the reset and interrupt vectors. These vectors must be stored in the destination RAM first, so that they can be fetched from program-memory addresses 0000h–003Fh. The reset vector will be fetched from 0000h. For a list of all the assigned vector locations, see subsection 5.6.2, *Interrupt Table*, on page 5-16.
-

Figure 4–9 shows how to store a 16-bit program into the 8-bit EPROM. A subscript h (for example, on Word1_h) indicates the high-byte and a subscript l (for example, on Word1_l) indicates the low byte.

Figure 4–9. Storing the Program in the EPROM

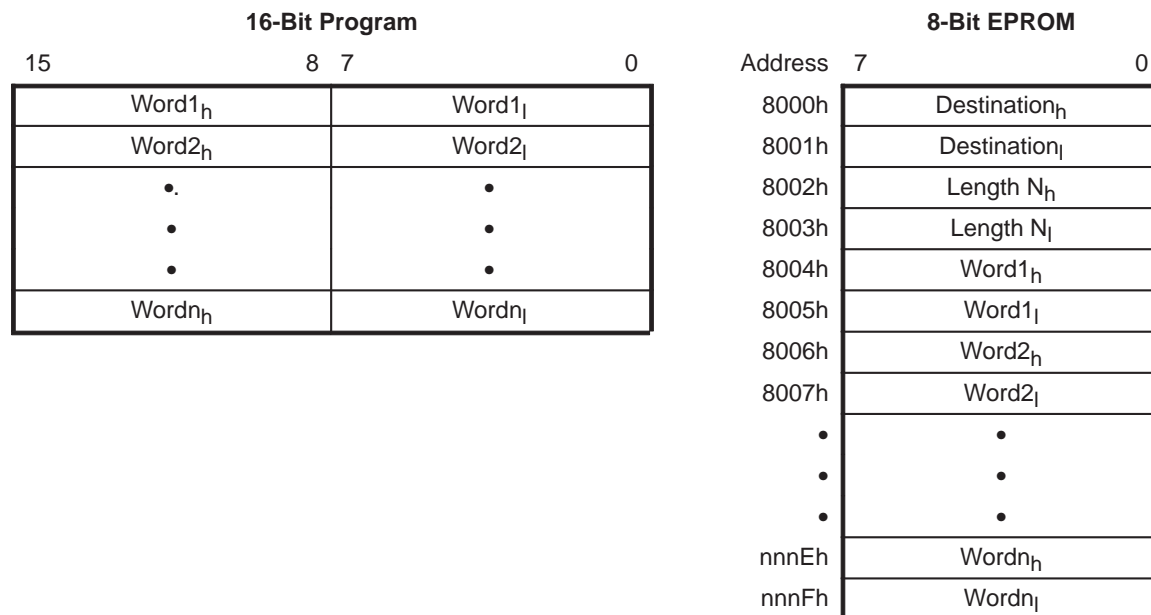

4.5.4 Enabling the Boot Loader

To enable the boot loader, tie the $\overline{\text{BOOT}}$ pin low and reset the device. The $\overline{\text{BOOT}}$ pin is sampled only at reset. If you don't want to use the boot loader, tie $\overline{\text{BOOT}}$ high before initiating a reset.

Three main conditions occur at reset that ensure proper operation of the boot loader:

- All maskable interrupts are globally disabled (INTM bit = 1).
- On-chip DARAM block B0 is mapped to data space (CNF bit = 0).
- Seven wait states are selected for program and data spaces.

After a hardware reset, the processor either executes the boot loader software or skips execution of the boot loader, depending on the level on the $\overline{\text{BOOT}}$ pin:

- If $\overline{\text{BOOT}}$ is low, the processor branches to the location of the on-chip boot loader program.
- If $\overline{\text{BOOT}}$ is high, the processor begins program execution at the address pointed to by the reset vector at address 0000h in program memory.

4.5.5 Boot Loader Execution

Once the EPROM has been programmed and installed, and the boot loader has been enabled, the processor automatically boots the program from EPROM at startup. If you need to reboot the processor during operation, bring the \overline{RS} pin low to cause a hardware reset.

When the processor executes the boot loader, the program first enables the full 32K words of global data memory by setting the eight LSBs of the GREG register to 80h. Next, the boot loader copies your program from the EPROM in global data space to the RAM in program space through a five step process (refer to Figure 4–10):

- 1) The boot loader loads the first two bytes from the EPROM and uses this word as the destination address for the code. (In Figure 4–10, the destination is 0000h.)
- 2) The boot loader loads the next two bytes to determine the length of the code.
- 3) The boot loader transfers the next two bytes. It loads the high byte first and the low byte second, combines the two bytes into one word, stores the new word in the destination memory location, and then increments the source and destination addresses.
- 4) The boot loader checks to see if the end of the program has been reached:
 - If the end is reached, the boot loader goes on to step 5.
 - If the end is not reached, the boot loader repeats steps 3 and 4.
- 5) The boot loader disables the entire global memory and then forces a branch to the reset vector at address 0000h in program memory. Once the boot loader finishes operation, the processor switches the on-chip boot loader out of the memory map.

Note:

During the boot load, data is read using the low-order eight data lines (D7–D0). The upper eight data lines are not used by the boot loader code.

Figure 4–10. Program Code Transferred From 8-Bit EPROM to 16-Bit RAM

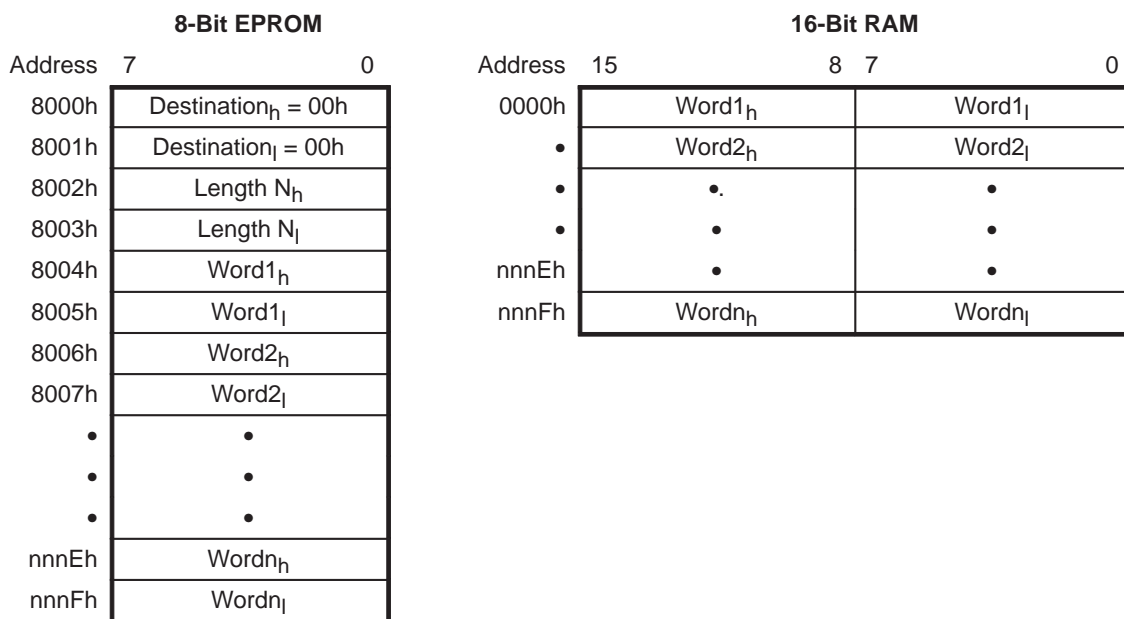

The 'C2xx fetches its interrupt vectors from program-memory locations 0000h–003Fh (the reset vector is fetched from 0000h). Make sure that the interrupt vectors are stored at the top of the EPROM, so that they will be transferred to addresses 0000h–003Fh in the RAM (see Figure 4–11). Each interrupt vector is a branch instruction, which requires four 8-bit words, and there is space for 32 interrupt vectors. Therefore, the first 128 words to be transferred from the EPROM should be the interrupt vectors.

Figure 4–11. Interrupt Vectors Transferred First During Boot Load

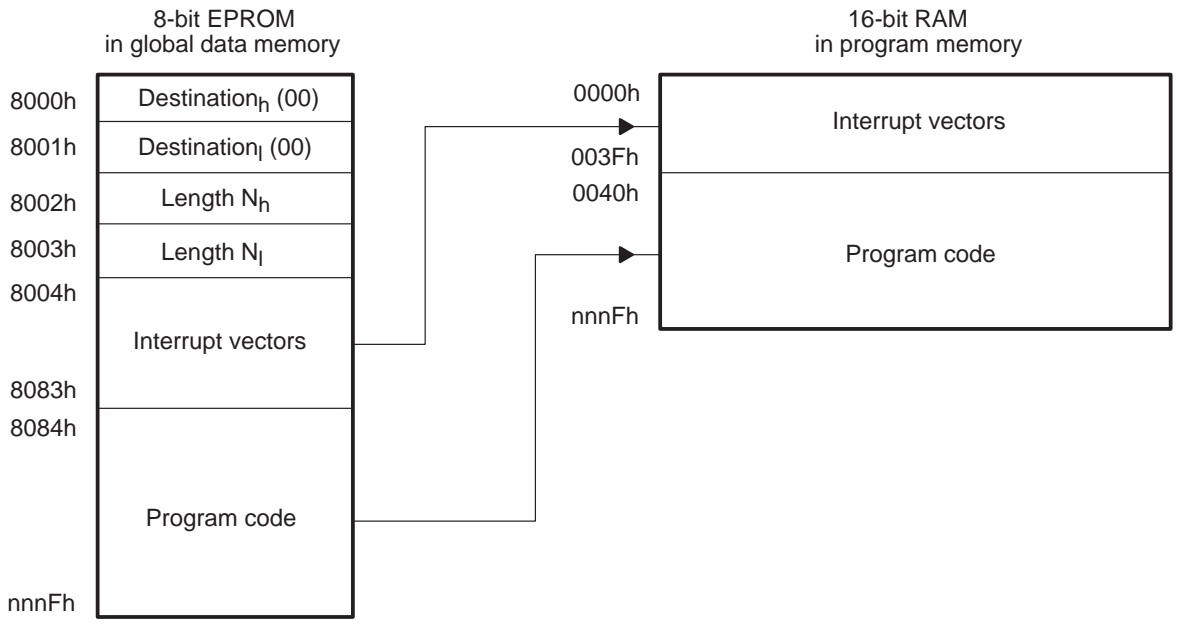

4.5.6 Boot Loader Program

```

*****
*   TMS320C2xx Boot Loader Program                                     *
*                                                                 *
*   This code sets up and executes boot loader code that loads program *
*   code from location 8000h in external global data space and transfers it *
*   to the destination address specified by the first word read from locations *
*   8000h and 8001h.                                               *
*****
        .length 60
GREG    .set    5h          ; The GREG Register
SRC     .set    8000h       ; Source address
DEST    .set    60h        ; Destination address
LENGTH .set    61h        ; Code length
TEMP   .set    62h        ; Temporary storage
HBYTE  .set    63h        ; Temporary storage for upper half of 16-bit word
CODEWORD .set    64h      ; Hold program code word
        .sect    "bootload"

*
*   Initialization
*
BOOT    LDP     #0          ; Set the data page to 0 (load DP with 0)
        SPLK   #2E00h,TEMP ; Set ARP = 1, OVM = 1, INTM = 1, DP = 0
        LST    #0,TEMP
        SPLK   #21FCh,TEMP ; Set ARB = 1, CNF = 0, SXM = 0, XF = 1, PM = 0
        LST    #1,TEMP
        SPLK   #80h,GREG   ; Designate locations 8000-FFFFH as global data
                           ; space
* * * * *
*   BOOT LOAD FROM 8-BIT MEMORY. MOST SIGNIFICANT BYTE IS FIRST *
* * * * *
*
*   Determine destination address
*
ADDR    LAR     AR1,#SRC    ; AR1 points to global address 8000h
        LACC   **+,8      ; Load ACC with high byte shifted left by 8 bits
        SACL   HBYTE      ; Store high byte
        LACL   **+        ; Load ACC with low byte of destination
        AND    #0FFH      ; Mask off upper 24 bits.
        OR     HBYTE      ; OR ACC with high byte to form 16-bit
                           ; destination address
        SACL   DEST       ; Store destination address

*
*   Determine length of code to be transferred
*
LEN     LACC   **+,8      ; Load ACC with high byte shifted left by 8 bits
        SACL   HBYTE      ; Store high byte
        LACL   **+        ; Load ACC with low byte of length
        AND    #0FFH      ; Mask off upper 24 bits.
        OR     HBYTE      ; OR ACC with high byte to form 16-bit length
        SACL   LENGTH     ; Store length
        LAR    AR0,LENGTH ; Load AR0 with length to be used for BANZ

```

```
*
* Transfer code
*
LOOP    LACC    *+,8          ; Load ACC with high byte of code shifted by 8 bits
        SACL    HBYTE        ; Store high byte
        LACL    *+,AR0       ; Load ACC with low byte of code
        AND     #0FFH        ; Mask off upper 24 bits
        OR      HBYTE        ; OR ACC with high byte to form 16-bit code word
        SACL    CODEWORD     ; Store code word
        LACL    DEST         ; Load destination address
        TBLW   CODEWORD     ; Transfer code to destination address
        ADD     #1           ; Add 1 to destination address
        SACL    DEST         ; Save new address
        BANZ   LOOP,AR1     ; Determine if end of code is reached
        SPLK   #0,GREG      ; Disable entire global memory
        INTR   0            ; Branch to reset vector and execute code.

.END
```

Note:

The INTR instruction in the boot loader program causes the processor to push a return address onto the stack, but the device does not use a RET to return to this address. Therefore, your program must execute a POP instruction to get the address off the stack.

4.6 I/O Space

The 'C2xx supports an I/O address range of 64K 16-bit words. Figure 4–12 shows the 'C2xx I/O address map.

Figure 4–12. I/O Address Map for the 'C2xx

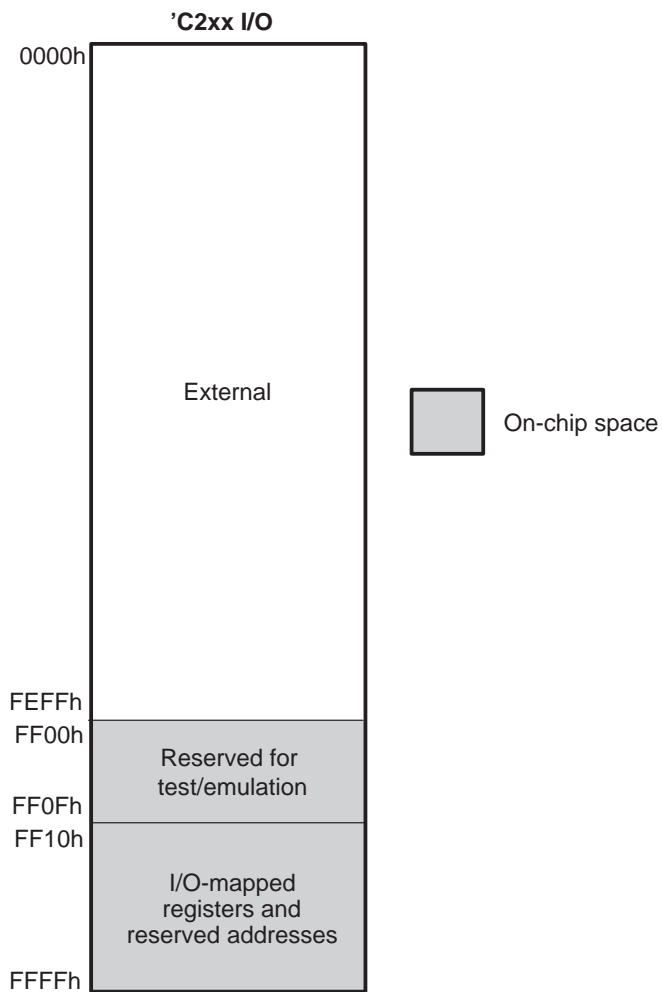

The map has three main sections of addresses:

- ❑ Addresses 0000h–FEFFh allow access to off-chip peripherals typically used in DSP applications, such as digital-to-analog and analog-to-digital converters.
- ❑ Addresses FF00h–FF0Fh are mapped to on-chip I/O space. These addresses are reserved for test purposes and should not be used.
- ❑ Addresses FF10h–FFFFh are also mapped to on-chip I/O space. These addresses are used for other reserved space and for the on-chip I/O-mapped registers. For 'C2xx devices other than the 'C209, Table 4–4 lists the registers mapped to on-chip I/O space. For the I/O-mapped registers on the 'C209, see Section 11.2, on page 11-5.

Do Not Write to Reserved Addresses

To avoid unpredictable operation of the processor, do not write to I/O addresses FF00h–FF0Fh or any reserved I/O address in the range FF10–FFFFh (that is, any address not designated for an on-chip peripheral.)

Table 4–4. On-Chip Registers Mapped to I/O Space

I/O Address	Name	Description
FFE8h	CLK	CLK register
FFEC	ICR	Interrupt control register
FFF0h	SDTR	Synchronous serial port transmit and receive register
FFF1h	SSPCR	Synchronous serial port control register
FFF4h	ADTR	Asynchronous serial port transmit and receive register
FFF5h	ASPCR	Asynchronous serial port control register
FFF6h	IOSR	Input/output status register
FFF7h	BRD	Baud rate divisor register
FFF8h	TCR	Timer control register
FFF9h	PRD	Timer period register
FFFAh	TIM	Timer counter register
FFFCh	WSGR	Wait-state generator control register

Note: This table does not apply to the 'C209. For the I/O-mapped registers on the 'C209, see Section 11.2 on page 11-5.

4.6.1 Accessing I/O Space

All I/O words (external I/O ports and on-chip I/O registers) are accessed with the IN and OUT instructions. Accesses to external parallel I/O ports are multiplexed over the same address and data buses for program and data-memory accesses. These accesses are distinguished from external program and data-memory accesses by \overline{IS} going low. The data bus is 16 bits wide; however, if you use 8-bit peripherals, you can use either the higher or lower eight lines of the data bus to suit a particular application.

You can use \overline{RD} with chip-select logic to generate an output-enable signal for an external peripheral. You can also use the \overline{WE} signal with chip-select logic to generate a write-enable signal for an external peripheral. As an example of interfacing to external I/O space, Figure 4–13 shows interface circuitry for eight input bits and eight output bits. Note that the decode section is simplified if fewer I/O ports are used.

Figure 4-13. I/O Port Interface Circuitry

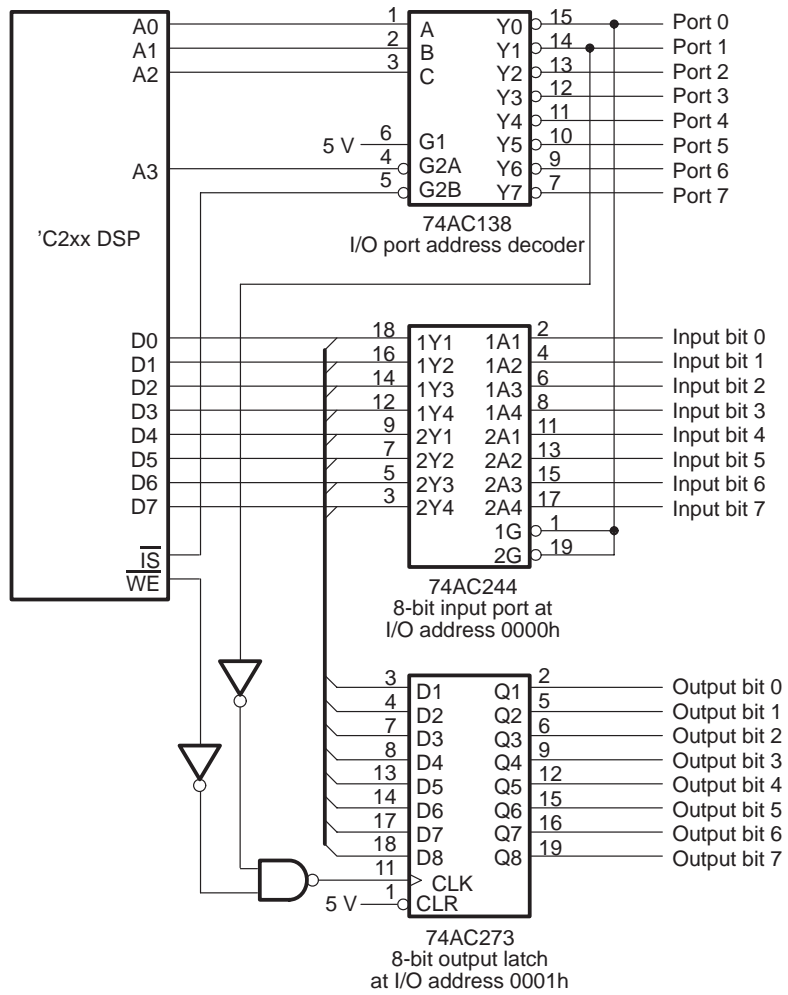

4.7 Direct Memory Access Using the HOLD Operation

The 'C2xx HOLD operation allows direct-memory access to external program, data, and I/O spaces. The process is controlled by two signals:

- ❑ **HOLD.** An external device can drive the $\overline{\text{HOLD}}/\overline{\text{INT1}}$ pin low to request control over the external buses. If the HOLD/INT1 interrupt line is enabled, this triggers an interrupt.
- ❑ **HOLDA.** In response to a $\overline{\text{HOLD}}$ interrupt, software logic can cause the processor to issue a $\overline{\text{HOLD}}$ acknowledge (HOLDA pin low), to indicate that it is relinquishing control of its external lines. Upon $\overline{\text{HOLDA}}$, the external address signals (A15–A0), data signals (D15–D0), and memory-control signals ($\overline{\text{PS}}$, $\overline{\text{DS}}$, $\overline{\text{BR}}$, $\overline{\text{IS}}$, $\overline{\text{STRB}}$, $\overline{\text{R/W}}$, $\overline{\text{RD}}$, $\overline{\text{WE}}$) are placed in high impedance.

Following a negative edge on the $\overline{\text{HOLD}}/\overline{\text{INT1}}$ pin, if interrupt line HOLD/INT1 is enabled, the CPU branches to address 0002h (this branch could also be accomplished with an INTR 1 instruction). Here the CPU fetches the interrupt vector and follows it to the interrupt service routine. If you wish to use this routine for HOLD operations and also for the interrupt $\overline{\text{INT1}}$, the tasks carried out by this routine will depend on the value of the MODE bit:

- ❑ **MODE = 1.** When the CPU detects a negative edge on $\overline{\text{HOLD}}/\overline{\text{INT1}}$, it finishes executing the current instruction (or repeat operation) and then forces program control to the interrupt service routine. The interrupt service routine, after successfully testing for MODE = 1, performs the tasks for $\overline{\text{INT1}}$.
- ❑ **MODE = 0.** Interrupt line INT1 is both negative- and positive-edge sensitive. When the CPU detects the negative edge, it finishes executing the current instruction (or repeat operation) and then forces program control to the interrupt service routine. This routine, after successfully testing for MODE = 0, executes an IDLE instruction. Upon IDLE, $\overline{\text{HOLDA}}$ is asserted and the external lines are placed in high impedance. Only after detecting a rising edge on the $\overline{\text{HOLD}}/\overline{\text{INT1}}$ pin, the CPU exits the IDLE state, deasserts $\overline{\text{HOLDA}}$, and returns the external lines to their normal states.

Example 4–1 shows an interrupt service routine that tests the MODE bit and acts accordingly. Note that the IDLE instruction should be placed inside the interrupt service routine to issue $\overline{\text{HOLDA}}$. Also note that the interrupt program code disables all maskable interrupts except $\overline{\text{HOLD}}/\overline{\text{INT1}}$ to allow safe recovery of $\overline{\text{HOLDA}}$ and the buses. Any other sequence of CPU code will cause undesirable bus control and is not recommended. (Interrupt operation is explained in detail in Section 5.6 on page 5-15.)

Example 4-1. An Interrupt Service Routine Supporting $\overline{INT1}$ and \overline{HOLD}

```

        .mmregs                ;Include c2xx memory-mapped registers.
ICR     .set    0FFFECh        ;Define interrupt control register in I/O space.
ICRSHDW .set    060h          ;Define ICRSHDW in scratch pad location.

*   Interrupt vectors   *
reset   B      main          ;0 - reset , Branch to main program on reset.
Int1h   B      int1_hold     ;1 - external interrupt 1 or HOLD.
        .space 40*16         ;Fill 0000 between vectors and main program.
main:   SPLK   #0001h,imr     ;Enable HOLD/INT1 interrupt line.
        CLRC   INTM
wait:   B      wait

*****Interrupt service routine for HOLD logic*****

int1_hold:
        ; Perform any desired context save.

        LDP   #0              ;Set data-memory page to 0.
        IN   ICRSHDW, ICR     ;Save the contents of ICR register.
        LACL #010h           ;Load accumulator (ACC) with mask for MODE bit.
        AND  ICRSHDW         ;Filter out all bits except MODE bit.
        BCND int1, neg       ;Branch if MODE bit is 1, else in HOLD mode.
        LACC imr, 0          ;Load ACC with interrupt mask register.
        SPLK #1, imr         ;Mask all interrupts except interrupt1/HOLD.
        IDLE                ;Enter HOLD mode. Issues HOLDA, and puts
                            ;buses in high impedance. Wait until
                            ;rising edge is seen on HOLD/INT1 pin.
        SPLK #1, ifr         ;Clear HOLD/INT1 flag in interrupt flag register
                            ;to prevent re-entering HOLD mode.
        SACL  imr            ;Restore interrupt mask register.

        ; Perform necessary context restore.

        CLRC  INTM          ;Enable all interrupts.
        RET                                ;Return from HOLD interrupt.

int1:   NOP                  ;Replace these NOPs with desired int1 interrupt
        NOP                  ;service routine.
        ; Perform necessary context restore.
        CLRC  INTM          ;Enable all interrupts.
        RET                                ;Return from interrupts.

```

Here are three valid methods for exiting the IDLE state, thus deasserting $\overline{\text{HOLDA}}$ and restoring the buses to normal operation:

- Cause a rising edge on the $\overline{\text{HOLD/INT1}}$ pin when $\text{MODE} = 0$.
- Assert system reset at the reset pin.
- Assert the nonmaskable interrupt $\overline{\text{NMI}}$ at the $\overline{\text{NMI}}$ pin.

If reset or $\overline{\text{NMI}}$ occurs while $\overline{\text{HOLDA}}$ is asserted, the CPU will deassert $\overline{\text{HOLDA}}$ regardless of the level on the $\overline{\text{HOLD/INT1}}$ pin. Therefore, to avoid further conflicts in bus control, the system hardware logic should restore $\overline{\text{HOLD}}$ to a high state.

4.7.1 $\overline{\text{HOLD}}$ During Reset

The HOLD logic can be used to put the buses in a high-impedance state at power-on or reset. This feature is useful in extending the DSP memory control to external processors. If $\overline{\text{HOLD}}$ is driven low during reset, normal reset operation occurs internally, but $\overline{\text{HOLDA}}$ will be asserted, placing all buses and control lines in a high-impedance state. Upon release of both $\overline{\text{HOLD}}$ and $\overline{\text{RS}}$, execution starts from program location 0000h.

Either of the following conditions will cause the processor to deassert $\overline{\text{HOLDA}}$ and return the buses to a normal state:

- HOLD is deasserted before reset is deasserted.** See Figure 4–14. This is the normal recovery condition after a HOLD operation. After the $\overline{\text{HOLD}}$ signal goes high, the $\overline{\text{HOLDA}}$ signal will be deasserted, and the buses will assume normal states.

Figure 4–14. $\overline{\text{HOLD}}$ Deasserted Before Reset Deasserted

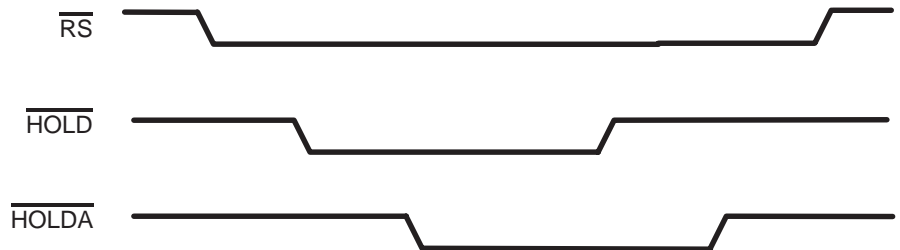

- Reset is deasserted before $\overline{\text{HOLD}}$ is deasserted.** See Figure 4–15. The CPU will deassert $\overline{\text{HOLDA}}$ regardless of the $\overline{\text{HOLD}}$ signal after the 16 clock cycles required for normal reset operation. Along with the $\overline{\text{HOLDA}}$ signal, the buses will assume normal states. The external system hardware logic should restore the $\overline{\text{HOLD}}$ signal to a high state to avoid conflicts in HOLD logic.

Figure 4-15. Reset Deasserted Before \overline{HOLD} Deasserted

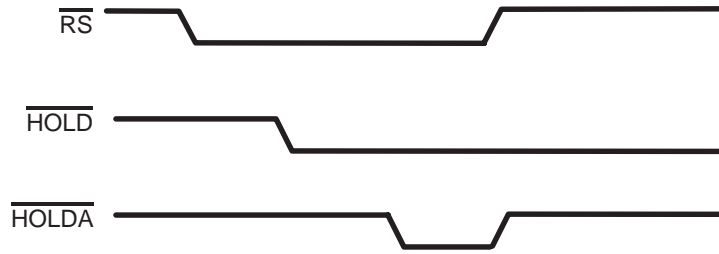

4.8 Device-Specific Information

For 'C2xx devices other than the 'C209, this section mentions the presence or absence of the boot loader and HOLD features, shows address maps, and explains the contents and configuration of the program-memory and data-memory maps. For details about the memory and I/O spaces of the 'C209, see Section 11.2 on page 11-5.

4.8.1 TMS320C203 Address Maps and Memory Configuration

The 'C203 has a 'C2xx on-chip boot loader and supports the 'C2xx HOLD operation. Figure 4–16 shows the 'C203 address map.

The on-chip program and data memory available on the 'C203 consists of:

- DARAM B0 (256 words, for program or data memory)
- DARAM B1 (256 words, for data memory)
- DARAM B2 (32 words, for data memory)

Figure 4–16. 'C203 Address Map

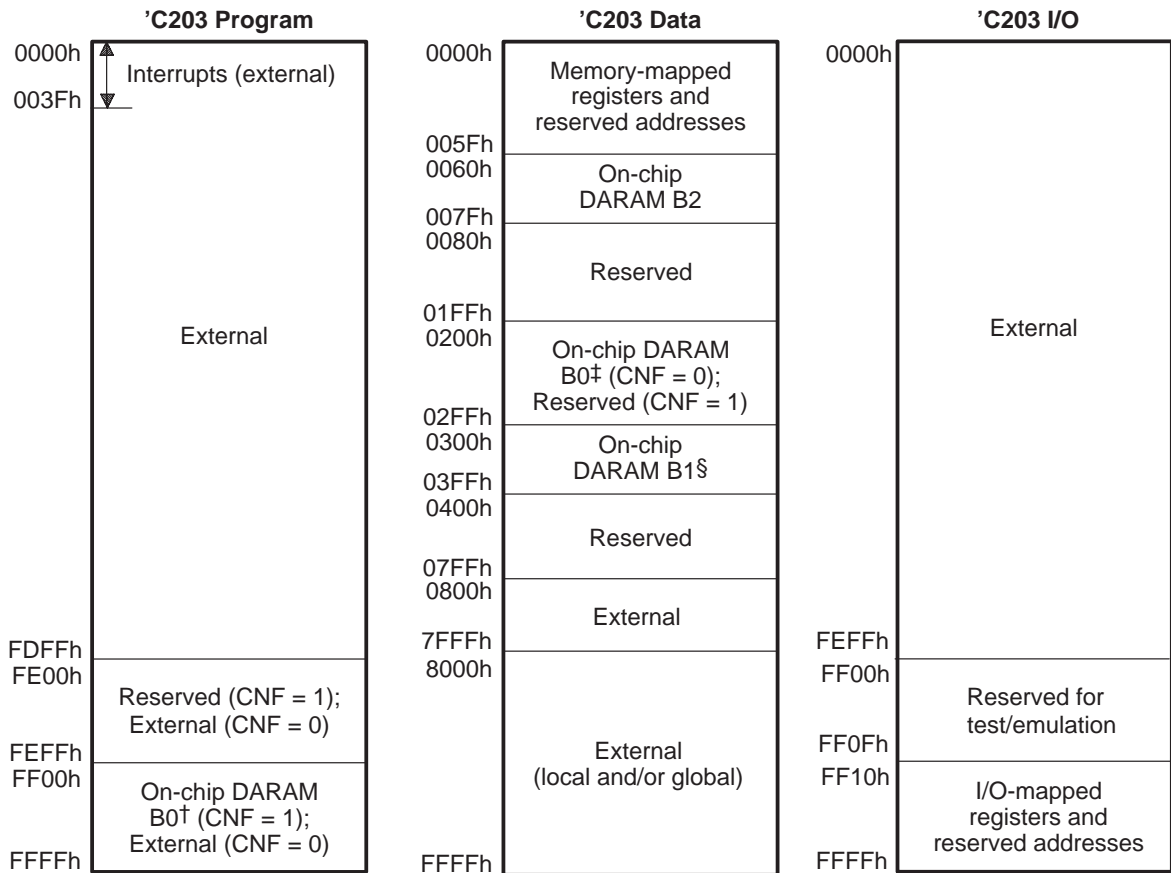

† When CNF = 1, addresses FE00h–FEFFh and FF00h–FFFFh are mapped to the same physical block (B0) in program-memory space. For example, a write to FE00h will have the same effect as a write to FF00h. For simplicity, addresses FE00h–FEFFh are referred to here as reserved when CNF = 1.

‡ When CNF = 0, addresses 0100h–01FFh and 0200h–02FFh are mapped to the same physical block (B0) in data-memory space. For example, a write to 0100h will have the same effect as a write to 0200h. For simplicity, addresses 0100h–01FFh are referred to here as reserved.

§ Addresses 0300h–03FFh and 0400h–04FFh are mapped to the same physical block (B1) in data-memory space. For example, a write to 0400h has the same effect as a write to 0300h. For simplicity, addresses 0400h–04FFh are referred to here as reserved.

DARAM blocks B1 and B2 are fixed, but DARAM block B0 may be mapped to program space or data space, depending on the value of the CNF bit (bit 12 of status register ST1):

- CNF = 0.** B0 is mapped to data space and is accessible at data addresses 0200h–02FFh. Note that the addressable external *program* memory increases by 512 words.
- CNF = 1.** B0 is mapped to program space and is accessible at program addresses FF00h–FFFFh.

At reset, CNF = 0.

Table 4–5 shows the program-memory options for the 'C203; Table 4–6 lists the data-memory options. Note these facts:

- Program-memory addresses 0000h–003Fh are used for the interrupt vectors.
- Data-memory addresses 0000h–005Fh contain on-chip memory-mapped registers and reserved memory.
- Two other on-chip data-memory ranges are always reserved: 0080h–01FFh and 0400h–07FFh.

Do Not Write to Reserved Addresses

To avoid unpredictable operation of the processor, do not write to any addresses labeled Reserved. This includes any data-memory address in the range 0000h–005Fh that is not designated for an on-chip register and any I/O address in the range FF00h–FFFFh that is not designated for an on-chip register.

Table 4–5. 'C203 Program-Memory Configuration Options

CNF	DARAM B0	External	Reserved
0	–	0000h–FFFFh	–
1	FF00h–FFFFh	0000h–FDFFh	FE00h–FEFFh

Table 4–6. 'C203 Data-Memory Configuration Options

CNF	DARAM B0 (hex)	DARAM B1 (hex)	DARAM B2 (hex)	External (hex)	Reserved (hex)
0	0200–02FF	0300–03FF	0060–007F	0800–FFFF	0000–005F 0080–01FF 0400–07FF
1	–	0300–03FF	0060–007F	0800–FFFF	0000–005F 0080–02FF 0400–07FF

4.8.2 TMS320C204 Address Maps and Memory Configuration

The 'C204 does not have an on-chip boot loader, but it does support the 'C2xx HOLD operation. Figure 4–16 shows the 'C204 address map. The on-chip program and data memory available on the 'C204 consists of:

- ROM (4K words, for program memory)
- DARAM B0 (256 words, for program or data memory)
- DARAM B1 (256 words, for data memory)
- DARAM B2 (32 words, for data memory)

Figure 4–17. 'C204 Address Map

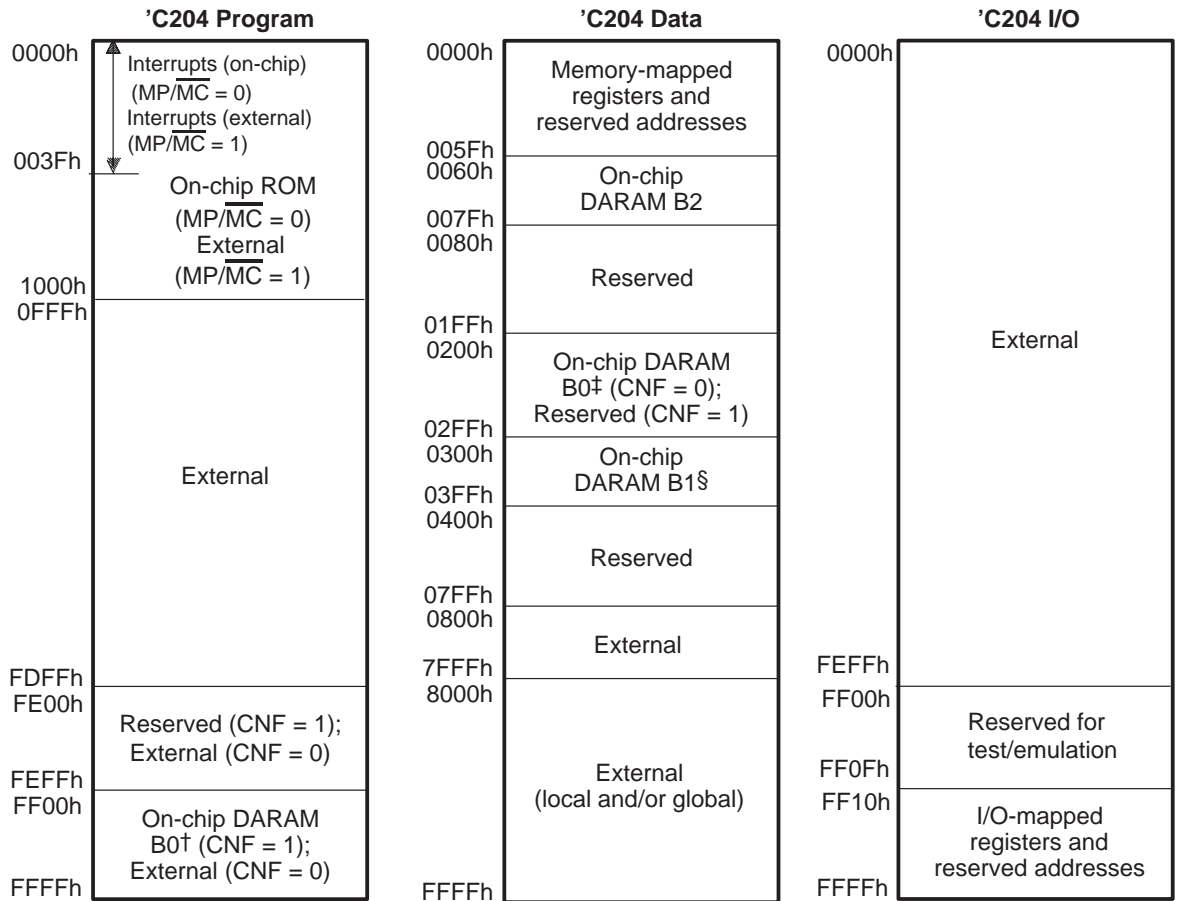

† When CNF = 1, addresses FE00h–FEFFh and FF00h–FFFFh are mapped to the same physical block (B0) in program-memory space. For example, a write to FE00h will have the same effect as a write to FF00h. For simplicity, addresses FE00h–FEFFh are referred to here as reserved when CNF = 1.

‡ When CNF = 0, addresses 0100h–01FFh and 0200h–02FFh are mapped to the same physical block (B0) in data-memory space. For example, a write to 0100h will have the same effect as a write to 0200h. For simplicity, addresses 0100h–01FFh are referred to here as reserved.

§ Addresses 0300h–03FFh and 0400h–04FFh are mapped to the same physical block (B1) in data-memory space. For example, a write to 0400h has the same effect as a write to 0300h. For simplicity, addresses 0400h–04FFh are referred to here as reserved.

You select or deselect the ROM by changing the level on the $\overline{\text{MP/MC}}$ pin at reset:

- $\overline{\text{MP/MC}} = 0$ at reset.** The device is configured as a microcomputer. The on-chip ROM is enabled and is accessible at addresses 0000h–0FFFh. The device fetches the reset vector from on-chip ROM.
- $\overline{\text{MP/MC}} = 1$ at reset.** The device is configured as a microprocessor, and addresses 0000h–0FFFh are used to access external memory. The device fetches the reset vector from external memory.

Regardless of the value of $\overline{\text{MP/MC}}$, the 'C2xx fetches its reset vector at location 0000h of program memory.

DARAM blocks B1 and B2 are fixed, but DARAM block B0 may be mapped to program space or data space, depending on the value of the CNF bit (bit 12 of status register ST1):

- CNF = 0.** B0 is mapped to data space and is accessible at data addresses 0200h–02FFh. Note that the addressable external *program* memory increases by 512 words.
- CNF = 1.** B0 is mapped to program space and is accessible at program addresses FF00h–FFFFh.

At reset, CNF = 0.

Table 4–7 lists the available program memory configurations for the 'C204; Table 4–8 lists the data-memory configurations. Note these facts:

- Program-memory addresses 0000h–003Fh are used for the interrupt vectors.
- Data-memory addresses 0000h–005Fh contain on-chip memory-mapped registers and reserved memory.
- Two other on-chip data-memory ranges are always reserved: 0080h–01FFh and 0400h–07FFh.

Do Not Write to Reserved Addresses

To avoid unpredictable operation of the processor, do not write to any addresses labeled Reserved. This includes any data-memory address in the range 0000h–005Fh that is not designated for an on-chip register and any I/O address in the range FF00h–FFFFh that is not designated for an on-chip register.

Table 4–7. 'C204 Program-Memory Configuration Options

MP/ $\overline{\text{MC}}$	CNF	ROM (hex)	DARAM B0 (hex)	External (hex)	Reserved (hex)
0	0	0000–0FFF	–	1000–FFFF	–
0	1	0000–0FFF	FF00–FFFF	1000–FDFF	FE00–FEFF
1	0	–	–	0000–FFFF	–
1	1	–	FF00–FFFF	0000–FDFF	FE00–FEFF

Table 4–8. 'C204 Data-Memory Configuration Options

CNF	DARAM B0 (hex)	DARAM B1 (hex)	DARAM B2 (hex)	External (hex)	Reserved (hex)
0	0200–02FF	0300–03FF	0060–007F	0800–FFFF	0000–005F 0080–01FF 0400–07FF
1	–	0300–03FF	0060–007F	0800–FFFF	0000–005F 0080–02FF 0400–07FF

Program Control

This chapter discusses the processes and features involved in controlling the flow of a program on the 'C2xx.

Program control involves controlling the order in which one or more blocks of instructions are executed. Normally, the flow of a program is sequential: the 'C2xx executes instructions at consecutive program-memory addresses. At times, a program must branch to a nonsequential address and then execute instructions sequentially at that new location. For this purpose, the 'C2xx supports branches, calls, returns, repeats, and interrupts.

The 'C2xx also provides a power-down mode, which halts internal program flow and temporarily lowers the power requirements of the 'C2xx.

Topic	Page
5.1 Program-Address Generation	5-2
5.2 Pipeline Operation	5-7
5.3 Branches, Calls, and Returns	5-8
5.4 Conditional Branches, Calls, and Returns	5-10
5.5 Repeating a Single Instruction	5-14
5.6 Interrupts	5-15
5.7 Reset Operation	5-33
5.8 Power-Down Mode	5-36

5.1 Program-Address Generation

Program flow requires the processor to generate the next program address (sequential or nonsequential) while executing the current instruction. Program-address generation is illustrated in Figure 5–1 and summarized in Table 5–1.

Figure 5–1. Program-Address Generation Block Diagram

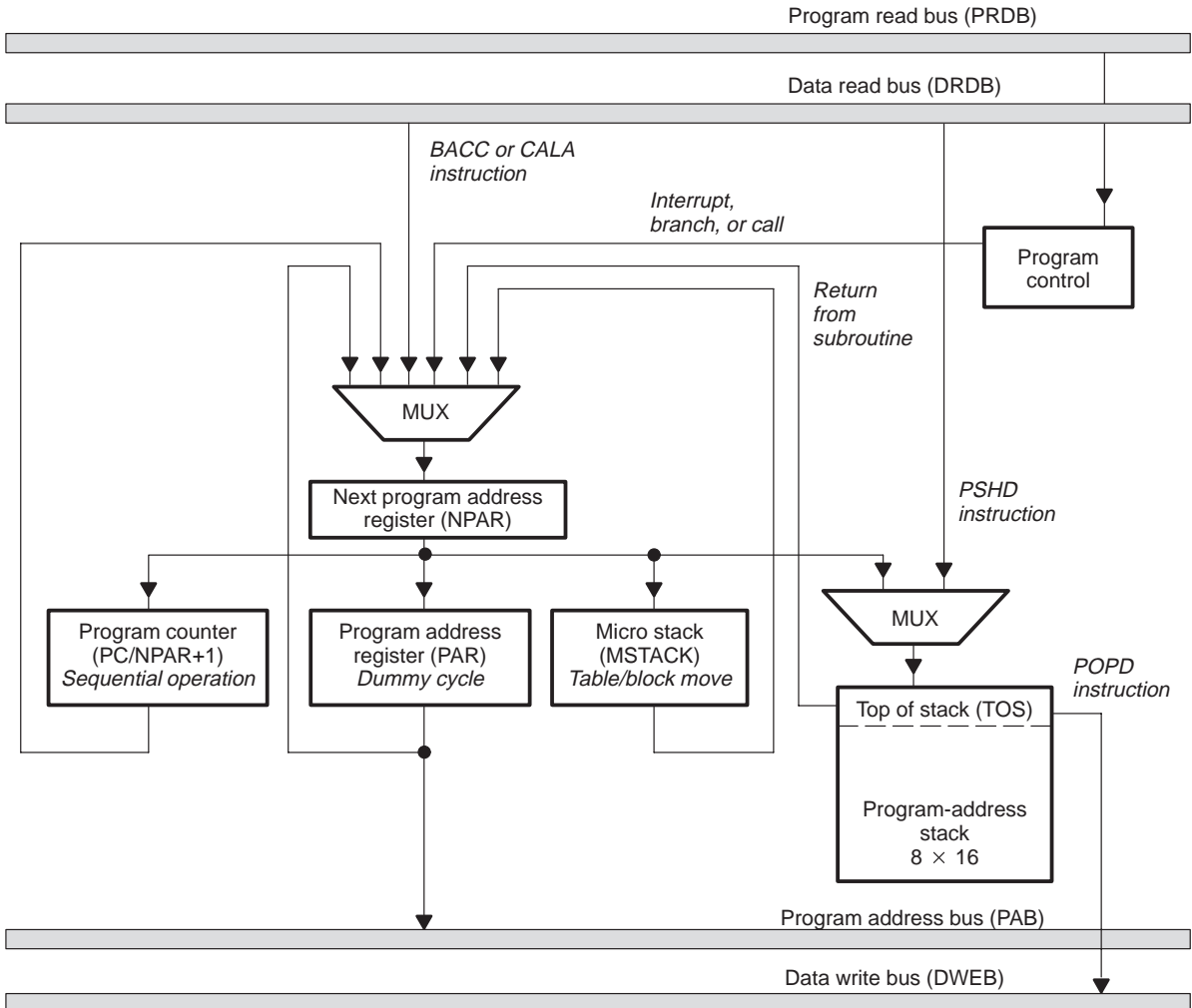

Table 5–1. Program-Address Generation Summary

Operation	Program-Address Source
Sequential operation	PC (contains program address +1)
Dummy cycle	PAR (contains program address)
Return from subroutine	Top of the stack (TOS)
Return from table move or block move	Micro stack (MSTACK)
Branch or call to address specified in instruction	Branch or call instruction by way of the program read bus (PRDB)
Branch or call to address specified in lower half of the accumulator	Low accumulator by way of the data read bus (DRDB)
Branch to interrupt service routine	Interrupt vector location by way of the program read bus (PRDB)

The 'C2xx program-address generation logic uses the following hardware:

- Program counter (PC).** The 'C2xx has a 16-bit program counter (PC) that addresses internal and external program memory when fetching instructions.
- Program address register (PAR).** The PAR drives the program address bus (PAB). The PAB is a 16-bit bus that provides program addresses for both reads and writes.
- Stack.** The program-address generation logic includes a 16-bit-wide, 8-level hardware stack for storing up to eight return addresses. In addition, you can use the stack for temporary storage.
- Micro stack (MSTACK).** Occasionally, the program-address generation logic uses the 16-bit-wide, 1-level MSTACK to store one return address.
- Repeat counter (RPTC).** The 16-bit RPTC is used with the repeat (RPT) instruction to determine how many times the instruction following RPT is repeated.

5.1.1 Program Counter (PC)

The program-address generation logic uses the 16-bit program counter (PC) to address internal and external program memory. The PC holds the address of the next instruction to be executed. Through the program address bus (PAB), an instruction is fetched from that address in program memory and loaded into the instruction register. When the instruction register is loaded, the PC holds the next address.

The 'C2xx can load the PC in a number of ways, to accommodate sequential and nonsequential program flow. Table 5–2 shows what is loaded to the PC according to the code operation performed.

Table 5–2. Address Loading to the Program Counter

Code Operation	Address Loaded to the PC
Sequential execution	The PC is loaded with PC + 1 if the current instruction has one word or PC + 2 if the current instruction has two words.
Branch	The PC is loaded with the long immediate value directly following the branch instruction.
Subroutine call and return	For a call, the address of the next instruction is pushed from the PC onto the stack, and then the PC is loaded with the long immediate value directly following the call instruction. A return instruction pops the return address back into the PC to return to the calling sequence of code.
Software or hardware interrupt	The PC is loaded with the address of the appropriate interrupt vector location. At this location is a branch instruction that loads the PC with the address of the corresponding interrupt service routine.
Computed GOTO	The content of the lower 16 bits of the accumulator is loaded into the PC. Computed GOTO operations can be performed using the BACC (branch to address in accumulator) or CALA (call subroutine at location specified by the accumulator) instructions.

5.1.2 Stack

The 'C2xx has a 16-bit-wide, 8-level-deep hardware stack. The program-address generation logic uses the stack for storing return addresses when a subroutine call or interrupt occurs. When an instruction forces the CPU into a subroutine or an interrupt forces the CPU into an interrupt service routine, the return address is loaded to the top of the stack automatically; this event does not require additional cycles. When the subroutine or interrupt service routine is complete, a return instruction transfers the return address from the top of the stack to the program counter.

When the eight levels are not used for return addresses, the stack may be used for saving context data during a subroutine or interrupt service routine, or for other storage purposes.

You can access the stack with two sets of instructions:

- PUSH and POP.** The PUSH instruction copies the lower half of the accumulator to the top of the stack. The POP instruction copies the value on the top of the stack to the lower half of the accumulator.

- ❑ **PSHD and POPD.** These instructions allow you to build a stack in data memory for the nesting of subroutines or interrupts beyond eight levels. The PSHD instruction pushes a data-memory value onto the top of the stack. The POPD instruction pops a value from the top of the stack to data memory.

Whenever a value is pushed onto the top of the stack (by an instruction or by the address-generation logic), the content of each level is pushed down one level, and the bottom (eighth) location of the stack is lost. Therefore, data is lost (stack overflow occurs) if more than eight successive pushes occur before a pop. Figure 5–2 shows a push operation.

Figure 5–2. A Push Operation

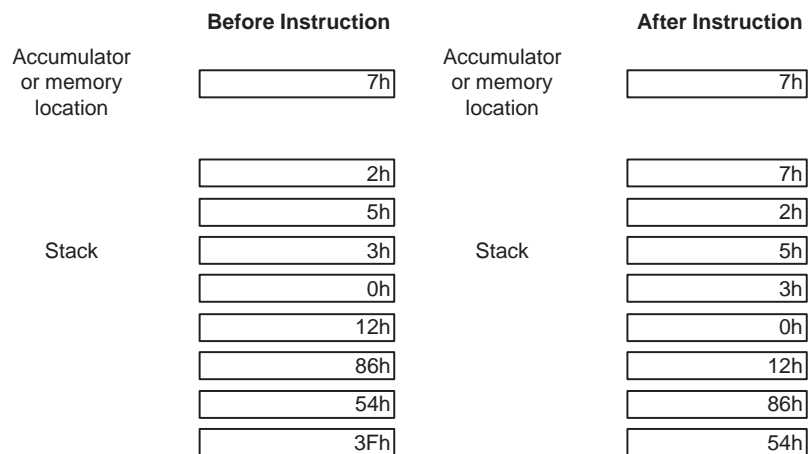

Pop operations are the reverse of push operations. A pop operation copies the value at each level to the next higher level. Any pop after seven sequential pops yields the value that was originally at the bottom of the stack because, by then, the bottom value has been copied upward to all of the stack levels. Figure 5–3 shows a pop operation.

Figure 5–3. A Pop Operation

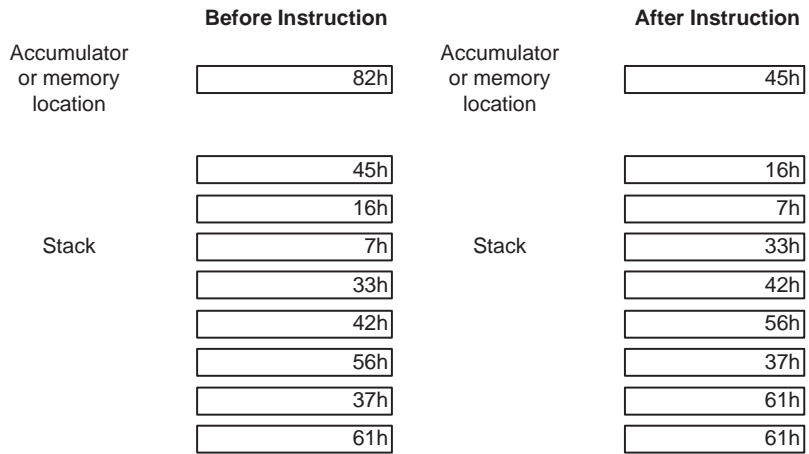

5.1.3 Micro Stack (MSTACK)

The program-address generation logic uses the 16-bit-wide, 1-level-deep MSTACK to store a return address before executing certain instructions. These instructions use the program-address generation logic to provide a second address in a two-operand instruction. These instructions are: BLDD, BLPD, MAC, MACD, TBLR, and TBLW. When repeated, these instructions use the PC to increment the first operand address and can use the auxiliary register arithmetic unit (ARAU) to generate the second operand address. When these instructions are used, the return address (the address of the next instruction to be fetched) is pushed onto the MSTACK. Upon completion of the repeated instruction, the MSTACK value is popped back into the program-address generation logic. The MSTACK operations are not visible to you. Unlike the stack, the MSTACK can be used only by the program-address generation logic; there are no instructions that allow you to use the MSTACK for storage.

5.2 Pipeline Operation

Instruction pipelining consists of a sequence of bus operations that occur during the execution of an instruction. The 'C2xx pipeline has four independent stages: instruction-fetch, instruction-decode, operand-fetch, and instruction-execute. Because the four stages are independent, these operations can overlap. During any given cycle, one to four different instructions can be active, each at a different stage of completion. Figure 5–4 shows the operation of the 4-level-deep pipeline for single-word, single-cycle instructions executing with no wait states.

The pipeline is essentially invisible to you except in the following cases:

- ❑ A single-word, single-cycle instruction immediately following a modification of the global-memory allocation register (GREG) uses the previous global map.
- ❑ The NORM instruction modifies the auxiliary register pointer (ARP) and uses the current auxiliary register (the one pointed to by the ARP) during the execute phase of the pipeline. If the next two instruction words change the values in the current auxiliary register or the ARP, they will do so during the instruction decode phase of the pipeline (before the execution of NORM). This would cause NORM to use the wrong auxiliary register value and the following instructions to use the wrong ARP value.

Figure 5–4. 4-Level Pipeline Operation

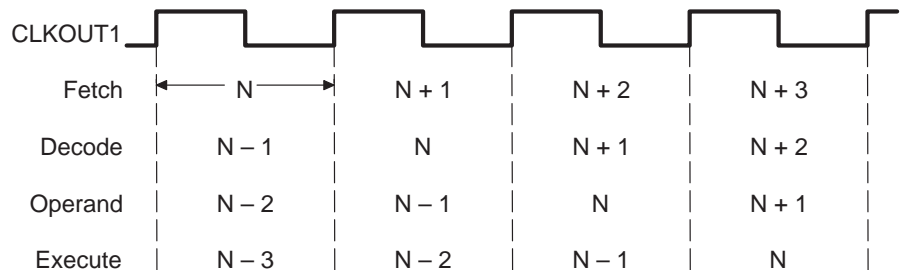

The CPU is implemented using 2-phase static logic. The 2-phase operation of the 'C2xx CPU consists of a master phase in which all commutation logic is executed, and a slave phase in which results are latched. Therefore, sequential operations require sequential master cycles. Although sequential operations require a deeper pipeline, 2-phase operation provides more time for the computational logic to execute. This allows the 'C2xx to run at faster clock rates despite having a deeper pipeline that imposes a penalty on branches and subroutine calls.

5.3 Branches, Calls, and Returns

Branches, calls, and returns break the sequential flow of instructions by transferring control to another location in program memory. A *branch* only transfers control to the new location. A *call* also saves the return address (the address of the instruction following the call) to the top of the hardware stack. Every called subroutine or interrupt service routine is concluded with a *return* instruction, which pops the return address off the stack and back into the program counter (PC).

The 'C2xx has two types of branches, calls, and returns:

- Unconditional.** An unconditional branch, call, or return is always executed. The unconditional branch, call, and return instructions are described in subsections 5.3.1, 5.3.2, and 5.3.3, respectively.
- Conditional.** A conditional branch, call, or return is executed only if certain specified conditions are met. The conditional branch, call, and return instructions are described in detail in Section 5.4, *Conditional Branches, Calls, and Returns*, on page 5-10.

5.3.1 Unconditional Branches

When an unconditional branch is encountered, it is always executed. During the execution, the PC is loaded with the specified program-memory address and program execution begins at that address. The address loaded into the PC may come from either the second word of the branch instruction or the lower sixteen bits of the accumulator.

By the time the branch instruction reaches the execute phase of the pipeline, the next two instruction words have already been fetched. These two instruction words are flushed from the pipeline so that they are not executed, and then execution continues at the branched-to address. The unconditional branch instructions are B (branch) and BACC (branch to location specified by accumulator).

5.3.2 Unconditional Calls

When an unconditional call is encountered, it is always executed. When the call is executed, the PC is loaded with the specified program-memory address and program execution begins at that address. The address loaded into the PC may come from either the second word of the call instruction or the lower sixteen bits of the accumulator. Before the PC is loaded, the return address is saved in the stack. After the subroutine or function is executed, a return instruction loads the PC with the return address from the stack, and execution resumes at the instruction following the call.

By the time the unconditional call instruction reaches the execute phase of the pipeline, the next two instruction words have already been fetched. These two instruction words are flushed from the pipeline so that they are not executed, the return address is stored to the stack, and then execution continues at the beginning of the called function. The unconditional call instructions are CALL and CALA (call subroutine at location specified by accumulator).

5.3.3 Unconditional Returns

When an unconditional return (RET) instruction is encountered, it is always executed. When the return is executed, the PC is loaded with the value at the top of the stack, and execution resumes at that address.

By the time the unconditional return instruction reaches the execute phase of the pipeline, the next two instruction words have already been fetched. The two instruction words are flushed from the pipeline so that they are not executed, the return address is taken from the stack, and then execution continues in the calling function.

5.4 Conditional Branches, Calls, and Returns

The 'C2xx provides branch, call, and return instructions that will execute only if one or more conditions are met. You specify the conditions as operands of the conditional instruction. Table 5–3 lists the conditions that you can use with these instructions and their corresponding operand symbols.

Table 5–3. Conditions for Conditional Calls and Returns

Operand Symbol	Condition	Description
EQ	ACC = 0	Accumulator equal to zero
NEQ	ACC ≠ 0	Accumulator not equal to zero
LT	ACC < 0	Accumulator less than zero
LEQ	ACC ≤ 0	Accumulator less than or equal to zero
GT	ACC > 0	Accumulator greater than zero
GEQ	ACC ≥ 0	Accumulator greater than or equal to zero
C	C = 1	Carry bit set to 1
NC	C = 0	Carry bit cleared to 0
OV	OV = 1	Accumulator overflow detected
NOV	OV = 0	No accumulator overflow detected
BIO	$\overline{\text{BIO}}$ low	$\overline{\text{BIO}}$ pin is low
TC	TC = 1	Test/control flag set to 1
NTC	TC = 0	Test/control flag cleared to 0

5.4.1 Using Multiple Conditions

Multiple conditions can be listed as operands of the conditional instructions. If multiple conditions are listed, all conditions must be met for the instruction to execute. Note that only certain combinations of conditions are meaningful. See Table 5–4. For each combination, the conditions must be selected from Group 1 and Group 2 as follows:

- Group 1.** You can select up to two conditions. Each of these conditions must be from a different category (A or B); you cannot have two conditions from the same category. For example, you can test EQ and OV at the same time, but you cannot test GT and NEQ at the same time.

- **Group 2.** You can select up to three conditions. Each of these conditions must be from a different category (A, B, or C); you cannot have two conditions from the same category. For example, you can test TC, C, and BIO at the same time, but you cannot test C and NC at the same time.

Table 5–4. Groupings of Conditions

Group 1		Group 2		
Category A	Category B	Category A	Category B	Category C
EQ	OV	TC	C	BIO
NEQ	NOV	NTC	NC	
LT				
LEQ				
GT				
GEQ				

5.4.2 Stabilization of Conditions

A conditional instruction must be able to test the most recent values of the status bits. Therefore, the conditions cannot be considered stable until the fourth, or execution, stage of the pipeline, one cycle after the previous instruction has been executed. The pipeline controller stops the decoding of any instructions following the conditional instruction until the conditions are stable.

5.4.3 Conditional Branches

A branch instruction transfers program control to any location in program memory. Conditional branch instructions are executed only when one or more user-specified conditions are met (see Table 5–3 on page 5-10). If all the conditions are met, the PC is loaded with the second word of the branch instruction, which contains the address to branch to, and execution continues at this address.

By the time the conditions have been tested, the two instruction words following the conditional branch instruction have already been fetched in the pipeline. If all the conditions are met, these two instruction words are flushed from the pipeline so that they are not executed, and then execution continues at the branched-to address. If the conditions are *not* met, the two instruction words are executed instead of the branch. Because conditional branches use conditions determined by the execution of the previous instructions, a conditional branch takes one more cycle than an unconditional one.

The conditional branch instructions are BCND (branch conditionally) and BANZ (branch if currently selected auxiliary register is not equal to 0). The BANZ instruction is useful for implementing loops.

5.4.4 Conditional Calls

The conditional call (CC) instruction is executed only when the specified condition or conditions are met (see Table 5–3 on page 5-10). This allows your program to choose among multiple subroutines based on the data being processed. If all the conditions are met, the PC is loaded with the second word of the call instruction, which contains the starting address of the subroutine. Before branching to the subroutine, the processor stores the address of the instruction following the call instruction—the return address—to the stack. The function must end with a return instruction, which will take the return address off the stack and force the processor to resume execution of the calling program.

By the time the conditions of the conditional call instruction have been tested, the two instruction words following the call instruction have already been fetched in the pipeline. If all the conditions are met, these two instruction words are flushed from the pipeline so that they are not executed, and then execution continues at the beginning of the called function. If the conditions are *not* met, the two instructions are executed instead of the call. Because there is a wait cycle for conditions to become stable, the conditional call takes one more cycle than the unconditional one.

5.4.5 Conditional Returns

Returns are used in conjunction with calls and interrupts. A call or interrupt stores a return address to the stack and then transfers program control to a new location in program memory. The called subroutine or the interrupt service routine concludes with a return instruction, which pops the return address off the top of the stack and into the program counter (PC).

The conditional return instruction (RETC) is executed only when one or more conditions are met (see Table 5–3 on page 5-10). By using the RETC instruction, you can give a subroutine or interrupt service routine more than one possible return path. The path chosen then depends on the data being processed. In addition, you can use a conditional return to avoid conditionally branching to/around the return instruction at the end of the subroutine or interrupt service routine.

If all the conditions are met for execution of the RETC instruction, the processor loads the return address from the stack to the PC and resumes execution of the calling or interrupted program.

RETC, like RET, is a single-word instruction. However, because of the potential PC discontinuity, it operates with the same effective execution time as the conditional branch (BCND) and the conditional call (CC). By the time the conditions of the conditional return instruction have been tested, the two instruction words following the return instruction have already been fetched in the pipeline. If all the conditions are met, these two instruction words are flushed from the pipeline so that they are not executed, and then execution of the calling program continues. If the conditions are *not* met, the two instructions are executed instead of the return. Because there is a wait cycle for conditions to become stable, the conditional return takes one more cycle than the unconditional one.

5.5 Repeating a Single Instruction

The 'C2xx repeat (RPT) instruction allows the execution of a single instruction $N + 1$ times, where N is specified as an operand of the RPT instruction. When RPT is executed, the repeat counter (RPTC) is loaded with N . RPTC is then decremented every time the repeated instruction is executed, until RPTC equals zero. RPTC can be used as a 16-bit counter when the count value is read from a data-memory location; if the count value is specified as a constant operand, it is in an 8-bit counter.

The repeat feature is useful with instructions such as NORM (normalize contents of accumulator), MACD (multiply and accumulate with data move), and SUBC (conditional subtract). When instructions are repeated, the address and data buses for program memory are free to fetch a second operand in parallel with the address and data buses for data memory. This allows instructions such as MACD and BLPD to effectively execute in a single cycle when repeated.

5.6 Interrupts

Interrupts are hardware- or software-driven signals that cause the 'C2xx to suspend its current program sequence and execute a subroutine. Typically, interrupts are generated by hardware devices that need to give data to or take data from the 'C2xx (for example, A/D and D/A converters and other processors). Interrupts can also signal that a particular event has taken place (for example, a timer has finished counting).

The 'C2xx supports both software and hardware interrupts:

- A *software interrupt* is requested by an instruction (INTR, NMI, or TRAP).
- A *hardware interrupt* is requested by a signal from a physical device. Two types exist:
 - *External hardware* interrupts are triggered by signals at external interrupt pins. All these interrupts are negative-edge triggered and should be active low for at least one CLKOUT1 period to be recognized.
 - *Internal hardware* interrupts are triggered by signals from the on-chip peripherals.

If hardware interrupts are triggered at the same time, the 'C2xx services them according to a set priority ranking. Each of the 'C2xx interrupts, whether hardware or software, can be placed in one of the following two categories:

- Maskable interrupts.** These are hardware interrupts that can be blocked (masked) or enabled (unmasked) through software.
- Nonmaskable interrupts.** These interrupts cannot be blocked. The 'C2xx will always acknowledge this type of interrupt and branch from the main program to a subroutine. The 'C2xx nonmaskable interrupts include all software interrupts and two external hardware interrupts: reset (\overline{RS}) and \overline{NMI} .

5.6.1 Interrupt Operation: Three Phases

The 'C2xx handles interrupts in three main phases:

- 1) **Receive the interrupt request.** Suspension of the main program must be requested by a software interrupt (from program code) or a hardware interrupt (from a pin or an on-chip device).
- 2) **Acknowledge the interrupt.** The 'C2xx must acknowledge the interrupt request. If the interrupt is maskable, certain conditions must be met in order for the 'C2xx to acknowledge it. For nonmaskable hardware interrupts and for software interrupts, acknowledgement is immediate.

- 3) **Execute the interrupt service routine.** Once the interrupt is acknowledged, the 'C2xx branches to its corresponding subroutine called an interrupt service routine (ISR). The 'C2xx follows the branch instruction you place at a predetermined address (the vector location) and executes the ISR you have written.

5.6.2 Interrupt Table

For 'C2xx devices other than the 'C209, Table 5–5 lists the interrupts available and shows their vector locations. In addition, it shows the priority of each of the hardware interrupts. For the corresponding 'C209 table, see Section 11.3, 'C209 Interrupts, on page 11-10.

Table 5–5. 'C2xx Interrupt Locations and Priorities

K†	Vector Location	Name	Priority	Function
0	0h	\overline{RS}	1 (highest)	Hardware reset (nonmaskable)
1	2h	$\overline{HOLD}/\overline{INT1}$	4	User-maskable interrupt #1
2	4h	$\overline{INT2}, \overline{INT3}‡$	5	User-maskable interrupts #2 and #3
3	6h	TINT	6	User-maskable timer interrupt
4	8h	RINT	7	User-maskable synchronous serial port receive interrupt
5	Ah	XINT	8	User-maskable synchronous serial port transmit interrupt
6	Ch	TXRXINT	9	User-maskable asynchronous serial port transmit/receive interrupt
7	Eh		10	Reserved
8	10h	INT8	–	User-defined software interrupt
9	12h	INT9	–	User-defined software interrupt

Note: This table does not apply to the 'C209. For the 'C209 interrupt table, see Section 11.3 on page 11-10.

† The K value is the operand used in an INTR instruction that branches to the corresponding interrupt vector location.

‡ INT2 and INT3 have separate pins but are tied to the same vector location.

Table 5–5. 'C2xx Interrupt Locations and Priorities (Continued)

K†	Vector Location	Name	Priority	Function
10	14h	INT10	–	User-defined software interrupt
11	16h	INT11	–	User-defined software interrupt
12	18h	INT12	–	User-defined software interrupt
13	1Ah	INT13	–	User-defined software interrupt
14	1Ch	INT14	–	User-defined software interrupt
15	1Eh	INT15	–	User-defined software interrupt
16	20h	INT16	–	User-defined software interrupt
17	22h	TRAP	–	TRAP instruction vector
18	24h	<u>NMI</u>	3	Nonmaskable interrupt
19	26h		2	Reserved
20	28h	INT20	–	User-defined software interrupt
21	2Ah	INT21	–	User-defined software interrupt
22	2Ch	INT22	–	User-defined software interrupt
23	2Eh	INT23	–	User-defined software interrupt
24	30h	INT24	–	User-defined software interrupt
25	32h	INT25	–	User-defined software interrupt
26	34h	INT26	–	User-defined software interrupt
27	36h	INT27	–	User-defined software interrupt
28	38h	INT28	–	User-defined software interrupt
29	3Ah	INT29	–	User-defined software interrupt
30	3Ch	INT30	–	User-defined software interrupt
31	3Eh	INT31	–	User-defined software interrupt

Note: This table does not apply to the 'C209. For the 'C209 interrupt table, see Section 11.3 on page 11-10.

† The K value is the operand used in an INTR instruction that branches to the corresponding interrupt vector location.

‡ INT2 and INT3 have separate pins but are tied to the same vector location.

5.6.3 Maskable Interrupts

When a maskable interrupt is successfully requested by a hardware device or by an external pin, the corresponding flag or flags are activated. These flags are activated whether or not the interrupt is later acknowledged by the processor.

Two registers on the 'C2xx contain flag bits:

- ❑ Interrupt flag register (IFR), a 16-bit, memory-mapped register located at address 0006h in data-memory space. The IFR is explained in detail in subsection 5.6.4
- ❑ Interrupt control register (ICR), a 16-bit register located at address FFECh in I/O space. The ICR is explained in subsection 5.6.6.

The IFR contains flag bits for all the maskable interrupts. The ICR contains additional flag bits for the interrupts $\overline{INT2}$ and $\overline{INT3}$. For all maskable interrupts except $\overline{INT2}$ and $\overline{INT3}$, an interrupt request is sent to the CPU as soon as the interrupt signal is sent by the pin or on-chip peripheral. For $\overline{INT2}$ or $\overline{INT3}$, the interrupt request is only sent to the CPU if the interrupt signal is not masked by its mask bit in the ICR. Figure 5–5 shows the process for successfully requesting $\overline{INT2}$ or $\overline{INT3}$.

Figure 5–5. $\overline{INT2}/\overline{INT3}$ Request Flow Chart

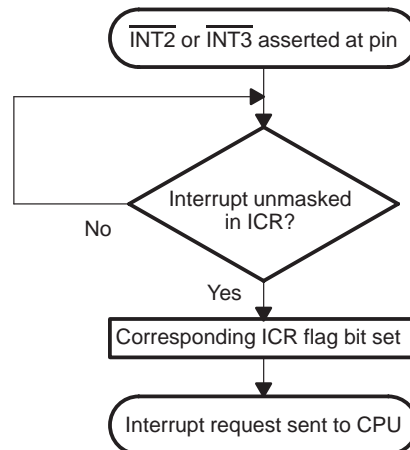

After an interrupt request is received by the CPU, the CPU must decide whether to acknowledge the request. Maskable hardware interrupts are acknowledged only after certain conditions are met:

- **Priority is highest.** When more than one hardware interrupt is requested at the same time, the 'C2xx services them according to a set priority ranking in which 1 indicates the highest priority. For the priorities of the hardware interrupts, see subsection 5.6.2 (on page 5-16).
- **IMR mask bit is 1.** The interrupt must be unmasked (enabled) in the interrupt mask register (IMR), a 16-bit, memory-mapped register located at address 0004h in data-memory space. The IMR contains mask bits for all the maskable interrupts. $\overline{\text{INT2}}$ and $\overline{\text{INT3}}$ share one of the bits in the IMR. The IMR is explained in subsection 5.6.5 on page 5-22.
- **INTM bit is 0.** The interrupt mode (INTM) bit, bit 9 of status register ST0, enables or disables all maskable interrupts:
 - When INTM = 0, all unmasked interrupts are enabled.
 - When INTM = 1, all unmasked interrupts are disabled.

INTM is set to 1 automatically when the CPU acknowledges an interrupt (except when initiated by the TRAP instruction). INTM can also be set to 1 by a hardware reset or by execution of a disable-interrupts instruction (SETC INTM). You can clear INTM by executing the enable-interrupts instruction (CLRC INTM). INTM has no effect on reset, $\overline{\text{NMI}}$, or software-interrupts (initiated with the TRAP, NMI, and INTR instructions). Also, INTM is unaffected by the LST (load status register) instruction.

INTM does not modify the interrupt flag register (IFR), the interrupt mask register (IMR), or the interrupt control register (ICR).

When the CPU acknowledges a maskable hardware interrupt, it loads the instruction bus with the INTR instruction. This instruction forces the CPU to branch to the corresponding *interrupt vector location*. From this location in program memory, the CPU fetches a branch that leads to the appropriate interrupt service routine. As the CPU branches to the interrupt service routine, it also sets the INTM bit to 1, preventing all hardware-initiated maskable interrupts from interrupting the execution of the ISR. Note that the INTR instruction can also be initiated directly by software; thus, the interrupt service routines for the maskable interrupts can also be initiated directly with the INTR instruction (see subsection 5.6.7, *Nonmaskable Interrupts* on page 5-27).

To determine which vector address has been assigned to each of the interrupts, see subsection 5.6.2 (on page 5-16). Interrupt vector locations are spaced apart by two addresses so a 2-word branch instruction can be accommodated in each of the locations.

Figure 5–6 summarizes how maskable interrupts are handled by the CPU.

Figure 5–6. Maskable Interrupt Operation Flow Chart

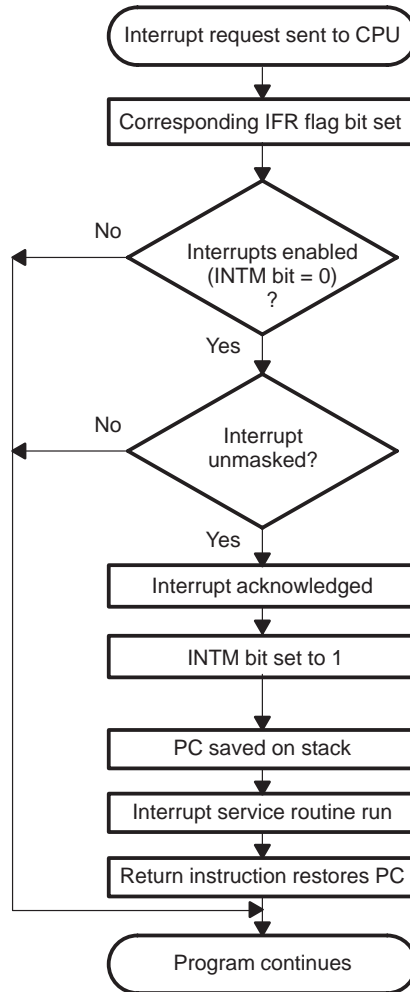

5.6.4 Interrupt Flag Register (IFR)

The 16-bit interrupt flag register (IFR), located at address 0006h in data memory space, contains flag bits for all the maskable interrupts. When a maskable interrupt request reaches the CPU, the corresponding flag is set to 1 in the IFR. This indicates that the interrupt is pending, or waiting for acknowledgement.

Read the IFR to identify pending interrupts, and write to the IFR to clear pending interrupts. To clear an interrupt request (and set its IFR flag to 0), write a

1 to the corresponding IFR bit. All pending interrupts can be cleared by writing the current contents of the IFR back into the IFR. Acknowledgement of a hardware request also clears the corresponding IFR bit. A device reset clears all IFR bits.

Notes:

- 1) When an interrupt is requested by an INTR instruction, if the corresponding IFR bit is set, the CPU will not clear it automatically. If an application requires that the IFR bit be cleared, the bit must be cleared in the interrupt service routine.
- 2) To avoid double interrupts from the synchronous serial port and the asynchronous serial port (including delta interrupts), clear the IFR bit(s) in the corresponding interrupt service routine, just before returning from the routine.

For 'C2xx devices other than the 'C209, Figure 5–7 shows the IFR. Descriptions of the bits follow the figure. For a description of the 'C209 IFR, see subsection 11.3.1, 'C209 Interrupt Registers, on page 11-11.

Figure 5–7. 'C2xx Interrupt Flag Register (IFR) — Data-Memory Address 0006h

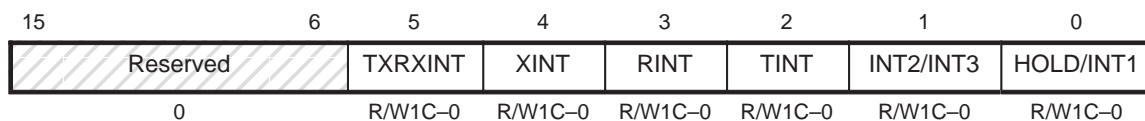

Note: 0 = Always read as zeros; R = Read access; W1C = Write 1 to this bit to clear it to 0; value following dash (–) is value after reset.

Bits 15–6 **Reserved.** Bits 15–6 are reserved and are always read as 0s.

Bit 5 **TXRXINT — Transmit/receive interrupt flag.** Bit 5 is tied to the transmit/receive interrupt for the asynchronous serial port. *To avoid double interrupts, write a 1 to this bit in the interrupt service routine.*

TXRXINT = 0 Interrupt TXRXINT is not pending.

TXRXINT = 1 Interrupt TXRXINT is pending.

Bit 4 **XINT — Transmit interrupt flag.** Bit 4 is tied to the transmit interrupt for the synchronous serial port. *To avoid double interrupts, write a 1 to this bit in the interrupt service routine.*

XINT = 0 Interrupt XINT is not pending.

XINT = 1 Interrupt XINT is pending.

- Bit 3** **RINT — Receive interrupt flag.** Bit 3 is tied to the receive interrupt for the synchronous serial port. *To avoid double interrupts, write a 1 to this bit in the interrupt service routine.*
- RINT = 0 Interrupt RINT is not pending.
- RINT = 1 Interrupt RINT is pending.
- Bit 2** **TINT — Timer interrupt flag.** Bit 2 is tied to the timer interrupt, TINT.
- TINT = 0 Interrupt TINT is not pending.
- TINT = 1 Interrupt TINT is pending.
- Bit 1** **INT2/INT3 — Interrupt 2/Interrupt 3 flag.** The $\overline{\text{INT2}}$ pin and the $\overline{\text{INT3}}$ pin are both tied to bit 1. If $\overline{\text{INT2}}$ is requested, INT2/INT3 and FINT2 (of the ICR) are both automatically set to 1. If $\overline{\text{INT3}}$ is requested, INT2/INT3 and FINT3 (of the ICR) are both automatically set to 1.
- INT2/INT3 = 0 Neither $\overline{\text{INT2}}$ nor $\overline{\text{INT3}}$ is pending.
- INT2/INT3 = 1 At least one of the two interrupts is pending. To determine which one is pending or if both are pending, read flag bits FINT2 and FINT3 in the interrupt control register (ICR). FINT2 and FINT3 are not automatically cleared when $\overline{\text{INT2}}$ and $\overline{\text{INT3}}$ are acknowledged by the CPU; they must be cleared by the interrupt service routine.
- Bit 0** **HOLD/INT1 — HOLD/Interrupt 1 flag.** Bit 0 is a flag for $\overline{\text{HOLD}}$ or $\overline{\text{INT1}}$. The operation of the $\overline{\text{HOLD/INT1}}$ pin differs depending on the value of the MODE bit in the interrupt control register (ICR). When MODE = 1, an interrupt is triggered only by a negative edge on the pin. When MODE = 0, interrupts can be triggered by both a negative edge and a positive edge. This is necessary to implement the 'C2xx HOLD operation (see Section 4.7, *Direct Memory Access Using The HOLD Operation*, on page 4-27).
- HOLD/INT1 = 0 $\overline{\text{HOLD/INT1}}$ is not pending.
- HOLD/INT1 = 1 $\overline{\text{HOLD/INT1}}$ is pending.

5.6.5 Interrupt Mask Register (IMR)

The 16-bit interrupt mask register (IMR), located at address 0004h in data-memory space, is used for masking external and internal hardware interrupts. Neither $\overline{\text{NMI}}$ nor $\overline{\text{RS}}$ is included in the IMR; thus, IMR has no effect on these interrupts.

Read the IMR to identify masked or unmasked interrupts, and write to the IMR to mask or unmask interrupts. To unmask an interrupt, set its corresponding IMR bit to 1. To mask an interrupt, set its corresponding IMR bit to 0. At reset, the IMR bits are all set to 0, masking all the maskable interrupts.

For 'C2xx devices other than the 'C209, Figure 5–8 shows the IMR. Descriptions of the bits follow the figure. For a description of the 'C209 IMR, see subsection 11.3.1, 'C209 Interrupt Registers, on page 11-11.

Figure 5–8. 'C2xx Interrupt Mask Register (IMR) — Data-Memory Address 0004h

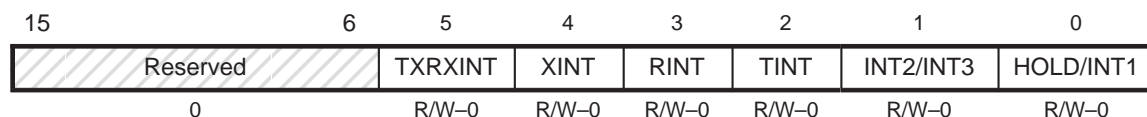

Note: 0 = Always read as zeros; R = Read access; W = Write access; value following dash (–) is value after reset.

Bits 15–6 **Reserved.** Bits 15–6 are reserved and are always read as 0s.

Bit 5 **TXRXINT — Transmit/receive interrupt mask.** Bit 5 is tied to the transmit/receive interrupt for the asynchronous serial port.

TXRXINT = 0 Interrupt TXRXINT is masked.

TXRXINT = 1 Interrupt TXRXINT is unmasked.

Bit 4 **XINT — Transmit interrupt mask.** Bit 4 is tied to the transmit interrupt for the synchronous serial port.

XINT = 0 Interrupt XINT is masked.

XINT = 1 Interrupt XINT is unmasked.

Bit 3 **RINT — Receive interrupt mask.** Bit 3 is tied to the receive interrupt for the synchronous serial port.

RINT = 0 Interrupt RINT is masked.

RINT = 1 Interrupt RINT is unmasked.

Bit 2 **TINT — Timer interrupt mask.** Bit 2 is tied to the interrupt for the timer.

TINT = 0 Interrupt TINT is masked.

TINT = 1 Interrupt TINT is unmasked.

Bit 1 **INT2/INT3 — Interrupt 2/Interrupt 3 mask.** The $\overline{\text{INT2}}$ pin and the $\overline{\text{INT3}}$ pin are both tied to bit 1. With this bit, you mask both $\overline{\text{INT2}}$ and $\overline{\text{INT3}}$ simultaneously. In conjunction with this bit, bits MINT2 and MINT3 of the ICR are used to individually unmask $\overline{\text{INT2}}$ and $\overline{\text{INT3}}$.

INT2/INT3 = 0 $\overline{\text{INT2}}$ and $\overline{\text{INT3}}$ are masked.

INT2/INT3 = 1 If INT2/INT3 = 1 and MINT2 = 1, $\overline{\text{INT2}}$ is unmasked.

 If INT2/INT3 = 1 and MINT3 = 1, $\overline{\text{INT3}}$ is unmasked.

Bit 0 **HOLD/INT1 — HOLD/Interrupt 1 mask.** This bit masks or un.masks interrupts requested at the $\overline{\text{HOLD/INT1}}$ pin.

$\text{HOLD/INT1} = 0$ $\overline{\text{HOLD/INT1}}$ is masked.

$\text{HOLD/INT1} = 1$ $\overline{\text{HOLD/INT1}}$ is unmasked.

5.6.6 Interrupt Control Register (ICR)

The 16-bit interrupt control register (ICR), located at address FFEC_h in I/O space, controls the function of the $\overline{\text{HOLD/INT1}}$ pin and individually controls the interrupts $\overline{\text{INT2}}$ and $\overline{\text{INT3}}$.

Controlling the $\overline{\text{HOLD/INT1}}$ pin

This pin can be used for triggering the interrupt $\overline{\text{INT1}}$ and for sending a $\overline{\text{HOLD}}$ signal to the CPU. Accordingly, the MODE bit provides two possible modes for the $\overline{\text{HOLD/INT1}}$ pin. When MODE = 1, the pin is negative-edge sensitive and, thus, is set appropriately for initiating a standard interrupt ($\overline{\text{INT1}}$). When MODE = 0, the pin is both negative- and positive-edge sensitive, which is necessary for implementing the logic for the HOLD operation (see Section 4.7, *Direct Memory Access Using The HOLD Operation*, on page 4-27). Regardless of the value of MODE, the pin is connected to the same interrupt logic, which initiates only one interrupt service routine. ($\overline{\text{HOLD/INT1}}$ is mapped to interrupt vector location 0002h in program memory.) To differentiate the two uses of the pin, the interrupt service routine must test the value of the MODE bit.

Controlling $\overline{\text{INT2}}$ and $\overline{\text{INT3}}$

Each of these interrupts has its own pin. However, they share:

- A single flag bit ($\overline{\text{INT2/INT3}}$) in the interrupt flag register (IFR).
- A single mask bit in the interrupt mask register (IMR).
- A single interrupt service routine. ($\overline{\text{INT2}}$ and $\overline{\text{INT3}}$ are mapped to interrupt vector location 0004h in program memory.)

To allow you to use $\overline{\text{INT2}}$ and $\overline{\text{INT3}}$ individually, the ICR provides two mask bits ($\overline{\text{MINT2}}$ and $\overline{\text{MINT3}}$) and two flag bits ($\overline{\text{FINT2}}$ and $\overline{\text{FINT3}}$).

When interrupts are requested on the pins $\overline{\text{INT2}}$ and $\overline{\text{INT3}}$, $\overline{\text{MINT2}}$ and $\overline{\text{MINT3}}$ determine whether the flag bits $\overline{\text{FINT2}}$, $\overline{\text{FINT3}}$, and $\overline{\text{INT2/INT3}}$ are set. To mask $\overline{\text{INT2}}$ (prevent the setting of flags $\overline{\text{FINT2}}$ and $\overline{\text{INT2/INT3}}$), write a 0 to $\overline{\text{MINT2}}$;

to mask $\overline{\text{INT3}}$ (prevent the setting of flags FINT3 and INT2/INT3) write a 0 to MINT3. If INT2/INT3 is not set, the CPU has not received and will not acknowledge the interrupt request.

When INT2/INT3 is set, one or both of the interrupts is pending. To differentiate the occurrences of the two interrupts, your interrupt service routine can test FINT2 and FINT3 and then branch to the appropriate subroutine. If you want the interrupt service routine to be executed only in response to one of the interrupts, mask the other interrupt in the ICR. Each of the ICR flag bits, like the IFR flag bit, can be cleared by writing a 1 to it.

Note:

- 1) Neither FINT2 nor FINT3 is automatically cleared when the CPU acknowledges the corresponding interrupt. If the application requires the bit(s) be cleared, the clearing must be done in the interrupt service routine.
 - 2) Writing 1s to FINT2 and FINT3 will set these bits to 0 but will *not* clear interrupt requests for $\overline{\text{INT2}}$ and $\overline{\text{INT3}}$. To clear requests for $\overline{\text{INT2}}$ and/or $\overline{\text{INT3}}$, write a 1 to the INT2/INT3 bit of the IFR.
-

If INT2 or INT3 is unmasked in the ICR, the IFR flag bit will be set regardless of bit 1 (INT2/INT3) in the IMR. If the IFR flag bit is set, the IMR bit is set, and the INTM bit is 0 (maskable interrupts are enabled), the CPU will acknowledge the interrupt. If an interrupt is masked by the IMR and/or the ICR, it will not be acknowledged, even if INTM = 0.

At reset, all ICR bits are set to zero, which means:

- The $\overline{\text{HOLD/INT1}}$ pin is both negative- and positive-edge sensitive (MODE = 0).
- The FINT2 and FINT3 flag bits are cleared.
- $\overline{\text{INT2}}$ and $\overline{\text{INT3}}$ are masked.

Figure 5–9 shows the ICR, and bit descriptions follow the figure.

Figure 5–9. 'C2xx Interrupt Control Register (ICR) — I/O-Space Address FFECh

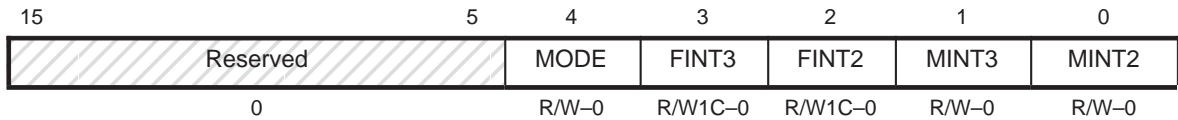

Note: 0 = Always read as zeros; R = Read access; W = Write access; W1C = Write 1 to this bit to clear it to 0; value following dash (–) is value after reset.

Bits 15–5 **Reserved.** Bits 15–5 are reserved and are always read as 0s.

Bit 4 **MODE — Pin mode.** Bit 4 selects one of two possible modes for the $\overline{\text{HOLD}}/\overline{\text{INT1}}$ pin.

MODE = 0 *Double-edge mode.* The $\overline{\text{HOLD}}/\overline{\text{INT1}}$ pin is both negative- and positive-edge sensitive. A falling edge or a rising edge triggers an interrupt request. This mode is necessary for proper implementation of a HOLD operation.

MODE = 1 *Single-edge mode.* A falling edge (only) on the $\overline{\text{HOLD}}/\overline{\text{INT1}}$ pin triggers an interrupt request.

Bit 3 **FINT3 — Interrupt 3 flag.** If MINT3 = 1, an interrupt request on the $\overline{\text{INT3}}$ pin sets FINT3 and bit 1 of the IFR (INT2/INT3).

FINT3 = 0 $\overline{\text{INT3}}$ is not pending.

FINT3 = 1 $\overline{\text{INT3}}$ is pending.

Bit 2 **FINT2 — Interrupt 2 flag.** If MINT2 = 1, an interrupt request on the $\overline{\text{INT2}}$ pin sets FINT2 and bit 1 of the IFR (INT2/INT3).

INT2 = 0 $\overline{\text{INT2}}$ is not pending.

INT2 = 1 $\overline{\text{INT2}}$ is pending.

Bit 1 **MINT3 — Interrupt 3 mask.** This bit masks the external interrupt $\overline{\text{INT3}}$ or, in conjunction with the INT2/INT3 bit of the IMR, unmask $\overline{\text{INT3}}$.

MINT3 = 0 $\overline{\text{INT3}}$ is masked. Neither FINT3 nor bit 1 of the IFR (INT2/INT3) is set by a request on the $\overline{\text{INT3}}$ pin.

MINT3 = 1 $\overline{\text{INT3}}$ is unmasked. Flag bits FINT3 and INT2/INT3 are both set by a request on the $\overline{\text{INT3}}$ pin.

- Bit 0** **MINT2 — Interrupt 2 mask.** This bit masks the external interrupt $\overline{\text{INT2}}$ or, in conjunction with the INT2/INT3 bit of the IMR, unmask $\overline{\text{INT2}}$.
- MINT2 = 0 $\overline{\text{INT2}}$ is masked. Neither FINT2 nor bit 1 of the IFR (INT2/INT3) is set by a request on the $\overline{\text{INT2}}$ pin.
- MINT2 = 1 $\overline{\text{INT2}}$ is unmasked. Flag bits FINT2 and INT2/INT3 are both set by a request on the $\overline{\text{INT2}}$ pin.

5.6.7 Nonmaskable Interrupts

Hardware nonmaskable interrupts can be requested through two pins:

- $\overline{\text{RS}}$ (reset).** $\overline{\text{RS}}$ is an interrupt that stops program flow, returns the processor to a predetermined state, and then begins program execution at address 0000h. For details of the reset operation, see Section 5.7, *Reset Operation*, on page 5-33. When $\overline{\text{RS}}$ is acknowledged, the interrupt mode (INTM) bit of status register ST1 is set to 1 to disable maskable interrupts.
- $\overline{\text{NMI}}$.** When $\overline{\text{NMI}}$ is activated (either by the $\overline{\text{NMI}}$ pin or by the NMI instruction), the processor switches program control to vector location 24h. In addition, maskable interrupts are disabled (the INTM bit of status register ST0 is set to 1). Although $\overline{\text{NMI}}$ uses the same logic as the maskable interrupts, it is not maskable. $\overline{\text{NMI}}$ happens regardless of the value of the INTM bit, and no mask bit exists for $\overline{\text{NMI}}$. If the $\overline{\text{NMI}}$ pin is not used, it should be pulled high to prevent an accidental interrupt.

$\overline{\text{NMI}}$ can be used as a soft reset. Unlike a hardware reset ($\overline{\text{RS}}$), the $\overline{\text{NMI}}$ neither affects any of the modes of the device nor aborts a currently active instruction or memory operation.

Software interrupts (which are inherently nonmaskable) are requested by the following instructions:

- INTR.** This instruction allows you to initiate any 'C2xx interrupt, including user-defined interrupts INT8 through INT16 and INT20 through INT31. The instruction operand (K) indicates which interrupt vector location the CPU will branch to. To determine the operand K that corresponds to each interrupt vector location see subsection 5.6.2 (on page 5-16). When an INTR interrupt is acknowledged, the interrupt mode (INTM) bit of status register ST1 is set to 1 to disable maskable interrupts.

Note:

The INTR instruction does not affect IFR flags. When you use the INTR instruction to initiate an interrupt that has an associated flag bit in the IFR, the instruction neither sets nor clears the flag bit. No software write operation can set the IFR flag bits; only the appropriate hardware requests can. If a hardware request has set the flag for an interrupt and then the INTR instruction is used to initiate that interrupt, the INTR instruction will not clear the flag.

- NMI.** This instruction forces a branch to interrupt vector location 24h, the same location used for the nonmaskable hardware interrupt $\overline{\text{NMI}}$. Thus, you can either initiate $\overline{\text{NMI}}$ by driving the $\overline{\text{NMI}}$ pin low or by executing an NMI instruction. When the NMI instruction is executed, INTM is set to 1 to disable maskable interrupts.
- TRAP.** This instruction forces the CPU to branch to interrupt vector location 22h. The TRAP instruction does *not* disable maskable interrupts (INTM is not set to 1); thus when the CPU branches to the interrupt service routine, that routine can be interrupted by the maskable hardware interrupts (in addition to $\overline{\text{RS}}$ and $\overline{\text{NMI}}$).

If the INTM bit is set to 1 during the acknowledgement process, all hardware-initiated maskable interrupts are disabled and, thus, cannot interfere with the interrupt service routine.

To determine which vector address has been assigned to each of the interrupts on a specific 'C2xx device, see subsection 5.6.2 (on page 5-16). Interrupt vector locations are spaced apart by two addresses so that a 2-word branch instruction can be accommodated in each location.

Figure 5–10 summarizes how nonmaskable interrupts are handled by the CPU.

Figure 5–10. Nonmaskable Interrupt Operation Flow Chart

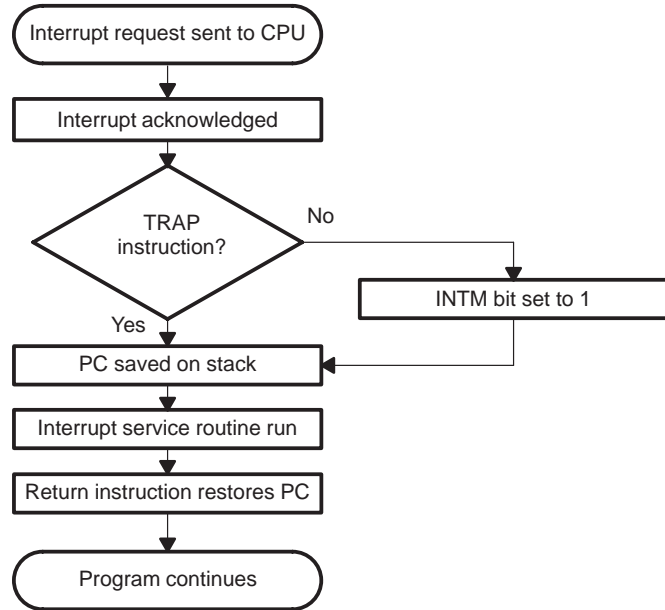

5.6.8 Interrupt Service Routines (ISRs)

After an interrupt has been requested and acknowledged, the CPU follows an interrupt vector to the ISR. The ISR is the program code that actually performs the tasks requested by the interrupt. While performing these tasks, the ISR may also be:

- Saving and restoring register values
- Managing ISRs within ISRs

Saving and restoring register values

Only the incremented program counter value is stored automatically before the CPU enters an interrupt service routine (ISR). You must design the ISR to save and then restore any other important register values. For example, if your ISR will need to perform a multiplication, it will need to use the product register (PREG). If the value currently in the PREG must be in the PREG after the ISR, the ISR must save the value, perform the new multiplication, store the resulting PREG value, and then reload the original value. You may find that certain registers will need to be saved during most ISRs. If so, you can copy a common save and restore routine and then individualize it for each interrupt.

Managing ISRs within ISRs

The 'C2xx hardware stack allows you to have ISRs within ISRs. When considering nesting ISRs like this, keep the following in mind:

- If you want the ISR be interrupted by a maskable interrupt, the ISR must unmask the interrupt by setting the appropriate IMR bit (and ICR bit, if applicable) and executing the enable-interrupts instruction (CLRC INTM).
- The hardware stack is limited to eight levels. Each time an interrupt is serviced or a subroutine is entered, the return address is pushed onto the hardware stack. This provides a way to return to the previous context afterwards. The stack contains eight locations, allowing interrupts or subroutines to be nested up to eight levels deep. (One level of the stack is reserved for debugging, to be used for breakpoint/single-step operations. If debugging is not used, this extra level is available for internal use.) If your software requires more than eight stack levels, you can use the POPD and PSHD instructions to effectively extend the stack into data memory.
- If you do not nest ISRs, you can avoid stack overflow. The 'C2xx has a feature that allows you to prevent unintentional nesting. If an interrupt occurs during the execution of a CLRC INTM instruction, the device always completes CLRC INTM as well as the next instruction before the pending interrupt is processed. This ensures that a return instruction that directly follows CLRC INTM will be executed before an interrupt is processed. The return instruction will pop the previous return address off the top of the stack before the new return address is pushed onto the stack.

To allow the CPU to complete the return, interrupts are also blocked after a RET instruction until at least one instruction at the return address is executed. Interrupts may be blocked for more than one instruction if the instruction at the return address requires additional blocking for pipeline protection.

- If you want an ISR to occur *within* the current ISR rather than *after* the current ISR, place the CLRC INTM instruction more than one instruction before the return (RET) instruction.

5.6.9 Interrupt Latency

The length of an interrupt latency—the delay between when an interrupt request is made and when it is serviced—depends on many factors. For example, the CPU always completes all instructions in the pipeline before executing a software vector. This subsection describes the factors that determine minimum latency and then describes factors that may cause additional latency. The maximum latency is a function of wait states and pipeline protection.

For an external, maskable hardware interrupt, a minimum latency of eight cycles is required to synchronize the interrupt externally, recognize the interrupt, and branch to the interrupt vector location. On the ninth cycle, the interrupt vector is fetched. For a software interrupt, the minimum latency consists of four cycles needed to branch to the interrupt vector location.

Latency for pipeline protection

Multicycle instructions add additional cycles to empty the pipeline. Instructions may become multicycle for these reasons:

- ❑ An instruction that writes to or reads from external memory may be delayed by wait states generated by the external READY pin or the on-chip wait-state generator. These wait states may affect the instruction being executed at the time the interrupt is requested, and they may affect the interrupt itself if the interrupt vector must be fetched from external memory.
- ❑ If an interrupt occurs during a HOLD operation and the interrupt vector must be fetched from external memory, the vector cannot be fetched until $\overline{\text{HOLDA}}$ is deasserted.
- ❑ When repeated with RPT, instructions run parallel operations in the pipeline and the context of these additional parallel operations cannot be saved in an interrupt service routine. To protect the context of the repeated instruction, the CPU locks out all interrupts except reset until the RPT loop completes.

Note:

Reset ($\overline{\text{RS}}$) is not delayed by multicycle instructions. $\overline{\text{NMI}}$ can be delayed by multicycle instructions.

Latency for stack overflow protection

A return address (incremented program counter value) is forced onto the hardware stack every time the CPU follows another interrupt service routine or other subroutine. However, the 'C2xx has a feature that can help you to keep the hardware stack from overflowing. Interrupts cannot be processed between the CLRC INTM (enable maskable interrupts) instruction and the next instruction in a program sequence. This ensures that a return instruction that directly follows CLRC INTM will be executed before an interrupt is processed. The return instruction will pop the previous return address off the top of the stack before the new return address is pushed onto the stack. If the interrupt were to occur

before the return, the new return address would be added to the hardware stack, even if the stack were already full.

To allow the CPU to complete the return, interrupts are also blocked after a RET instruction until at least one instruction at the return address is executed.

5.7 Reset Operation

Reset (\overline{RS}) is a nonmaskable external interrupt that can be used at any time to put the 'C2xx into a known state. Reset is the highest priority interrupt; no other interrupt takes precedence over reset. Reset is typically applied after power up when the machine is in an unknown state. Because the reset signal aborts memory operations and initializes status bits, the system should be re-initialized after each reset. The \overline{NMI} interrupt can be used for soft resets because it neither aborts memory operations nor initializes status bits.

Driving \overline{RS} low causes the 'C2xx to terminate execution and affects various registers and status bits. For correct system operation after power up, \overline{RS} must be asserted for at least six clock cycles. The device latches the reset pulse and generates an internal reset pulse long enough to ensure a device reset. The device fetches its first instruction 16 cycles after the rising edge of \overline{RS} . Processor execution begins at location 0000h, which normally contains a branch instruction to the system initialization routine.

When the 'C2xx receives a reset signal, the following actions take place:

Program-control features:

- The program counter is cleared to 0 (however, the address bus, A15–A0, is unknown while \overline{RS} is low).
- Status bits in registers ST0 and ST1 are loaded with their reset values: OV = 0, INTM = 1, CNF = 0, SXM = 1, C = 1, XF = 1 and PM = 00. (The other status bits remain undefined and should be initialized by a reset.)
- The INTM (interrupt mode) bit is set to 1, disabling all maskable interrupts. (\overline{RS} and \overline{NMI} are not maskable.) Also, the interrupt flag register (IFR), interrupt mask register (IMR), and interrupt control register (ICR) are cleared.
- The MODE bit of the interrupt control register (ICR) is set to 0 so that the $\overline{HOLD}/\overline{INT1}$ pin is both negative- and positive-edge sensitive.
- The repeat counter (RPTC) is cleared.

Memory and I/O spaces:

- A logic 0 is loaded into the CNF (configuration control) bit in status register ST1, mapping dual-access RAM block B0 into data space.
- The global memory allocation register (GREG) is cleared to make all memory local.
- The wait-state generator is set to provide the maximum number of wait states for external memory and I/O accesses.

□ **Peripherals:**

- The timer count is set to its maximum value (FFFFh), the timer divide-down value is set to 0, and the timer starts counting down.
- The synchronous serial port is reset:
 - The port emulation mode is set to immediate stop.
 - Error and status flags are reset.
 - Receive interrupts are set to occur when the receive buffer is not empty.
 - Transmit interrupts are set to occur when the transmit buffer can accept one or more words.
 - External clock and frame synchronization sources are selected.
 - Continuous mode is selected.
 - Digital loopback mode is disabled.
 - The receiver and transmitter are enabled.
- The asynchronous serial port is reset:
 - The port emulation mode is set to immediate stop.
 - Error and status flags are reset.
 - Receive, transmit, and delta interrupts are disabled.
 - One stop bit is selected.
 - Auto-baud alignment is disabled.
 - The TX pin is forced high between transmissions.
 - I/O pins IO0, IO1, IO2, and IO3 are configured as inputs.
 - A baud rate of (CLKOUT1 rate)/16 is selected.
 - The port is disabled.
- CLK register bit 0 is cleared to 0 so that the CLKOUT1 signal is available at the CLKOUT1 pin.

No other registers or status bits (such as the accumulator, DP, ARP, and the auxiliary registers) are initialized. Table 5–6 and Table 5–7 list the reset values for all the registers mapped to on-chip addresses.

Table 5–6. Reset Values of On-Chip Registers Mapped to Data Space

Name	Data-Memory Address	Reset Value	Description
IMR	0004h	0000h	Interrupt mask register
GREG	0005h	0000h	Interrupt control register
IFR	0006h	0000h	Synchronous data transmit and receive register

Table 5–7. Reset Values of On-Chip Registers Mapped to I/O Space

Name	I/O Address		Reset Value	Description
	'C209	Other 'C2xx		
CLK	–	FFE8h	0000h	CLKOUT1-pin control (CLK) register
ICR	–	FFEC h	0000h	Interrupt control register
SDTR	–	FFF0h	xxxxh	Synchronous data transmit and receive register
SSPCR	–	FFF1h	0030h	Synchronous serial port control register
ADTR	–	FFF4h	xxxxh	Asynchronous data transmit and receive register
ASPCR	–	FFF5h	0000h	Asynchronous serial port control register
IOSR	–	FFF6h	18xxh	I/O status register
BRD	–	FFF7h	0001h	Baud-rate divisor register
TCR	FFFCh	FFF8h	0000h	Timer control register
PRD	FFFDh	FFF9h	FFFFh	Timer period register
TIM	FFFEh	FFFAh	FFFFh	Timer counter register
WSGR	FFFFh	FFFC h	0FFFh	Wait-state generator control register

Note: An x in an address represents four bits that are either not affected by reset or dependent on pin levels at reset.

5.8 Power-Down Mode

The 'C2xx has a power-down mode that allows the 'C2xx core to enter a dormant state and use less power than during normal operation. Executing an IDLE instruction initiates power-down mode. When the IDLE instruction executes, the program counter is incremented once, and then all CPU activities are halted. While the 'C2xx is in power-down mode, all of its internal contents are maintained. The content of all on-chip RAM remains unchanged. The peripheral circuits continue to operate, allowing the serial ports and the timer to take the CPU out of the power-down state. The CLKOUT1 pin remains active if bit 0 of the CLK register is set to 0.

The methods for terminating power-down mode depend on whether the power-down was initiated under normal circumstances or as part of a HOLD operation. The following subsections describe the differences.

5.8.1 Normal Termination of Power-Down Mode

If power-down has been initiated, any hardware interrupt (internal or external) takes the processor out of the IDLE state. If you use reset or $\overline{\text{NMI}}$, the CPU will immediately execute the corresponding interrupt service routine. In addition, if you use reset, registers will assume their reset values.

For a maskable hardware interrupt to wake the processor, it must be unmasked by the interrupt mask register (IMR bit = 1). However, if the interrupt is unmasked and is then requested, the processor will leave the IDLE state regardless of the value of the INTM bit (bit 9 of status register ST0). The value of the INTM bit will only determine the action of the CPU *after* power-down has been terminated:

- INTM = 0.** The interrupt is enabled, and the CPU executes the corresponding interrupt service routine.
- INTM = 1.** The interrupt is disabled, and the CPU continues with the instruction after IDLE.

If you do not want the CPU to follow an interrupt service routine before continuing with the interrupted program sequence:

- Do not use reset or $\overline{\text{NMI}}$ to bring the processor out of power-down.
- Make sure your program globally disables maskable interrupts (sets INTM to 1) before IDLE is executed.

5.8.2 Termination of Power-Down During a HOLD Operation

One of the necessary steps in the HOLD operation is the execution of an IDLE instruction (see Section 4.7, *Direct Memory Access Using The HOLD Operation*, on page 4-27) . There are unique characteristics of the HOLD operation that affect how the IDLE state can be exited.

Before performing a HOLD operation, your program must write a 0 to the MODE bit (bit 4 of the interrupt control register, ICR). This makes the $\overline{\text{HOLD}}/\text{INT1}$ pin both negative- and positive-edge sensitive. A *falling* edge on $\overline{\text{HOLD}}/\text{INT1}$ will cause the CPU to branch to the interrupt service routine, which initiates the HOLD operation with an IDLE instruction. A subsequent *rising* edge on $\overline{\text{HOLD}}/\text{INT1}$ can take the CPU out of the IDLE state and end the HOLD operation. This rising-edge interrupt does *not* cause the CPU to branch to the interrupt service routine.

The recommended software logic for the HOLD operation is described in Section 4.7, *Direct Memory Access Using the HOLD Operation*, on page 4-27.

During a HOLD operation, there are only three valid methods for taking the CPU out of the IDLE state:

- Causing a rising edge on the $\overline{\text{HOLD}}/\text{INT1}$ pin.
- Asserting a system reset at the reset pin.
- Asserting the nonmaskable interrupt $\overline{\text{NMI}}$ at the $\overline{\text{NMI}}$ pin.

If you use reset or $\overline{\text{NMI}}$, the CPU will immediately execute the corresponding interrupt service routine. In addition, if you use reset, the contents of some registers will be changed. For more information about exiting a HOLD operation with reset or $\overline{\text{NMI}}$, see Section 4.7, *Direct Memory Access Using The HOLD Operation*, on page 4-27.

Addressing Modes

This chapter explains the three basic memory addressing modes used by the 'C2xx instruction set. The three modes are:

- Immediate addressing mode
- Direct addressing mode
- Indirect addressing mode

In immediate addressing, a constant to be manipulated by the instruction is supplied directly as an operand of that instruction. Two types of immediate addressing are available—short and long. In short-immediate addressing, an 8-, 9-, or 13-bit operand is included in the instruction word. Long-immediate addressing uses a 16-bit operand.

When you need to access data memory, you can use direct or indirect addressing. Direct addressing concatenates seven bits of the instruction word with the nine bits of the data-memory page pointer (DP) to form the 16-bit data memory address. Indirect addressing accesses data memory through one of eight 16-bit auxiliary registers.

Topic	Page
6.1 Immediate Addressing Mode	6-2
6.2 Direct Addressing Mode	6-4
6.3 Indirect Addressing Mode	6-9

Figure 6–2. Two Words Loaded Consecutively to the Instruction Register in Example 6–2

First instruction word:

15	14	13	12	11	10	9	8	7	6	5	4	3	2	1	0
1	0	1	1	1	1	1	1	1	0	0	1	0	0	1	0

ADD opcode for long-immediate addressing

shift = 2

Second instruction word:

15	14	13	12	11	10	9	8	7	6	5	4	3	2	1	0
0	1	0	0	0	0	0	0	0	0	0	0	0	0	0	0

16-bit constant = 16 384 = 4000h

6.2 Direct Addressing Mode

In the direct addressing mode, data memory is addressed in blocks of 128 words called data pages. The entire 64K of data memory consists of 512 data pages labeled 0 through 511, as shown in Figure 6–3. The current data page is determined by the value in the 9-bit data page pointer (DP) in status register ST0. For example, if the DP value is 000000000₂, the current data page is 0. If the DP value is 000000010₂, the current data page is 2.

Figure 6–3. Pages of Data Memory

DP value	Offset	Data Memory
0000 0000 0	000 0000	Page 0: 0000h–007Fh
⋮	⋮	
0000 0000 0	111 1111	Page 1: 0080h–00FFh
⋮	⋮	
0000 0000 1	000 0000	Page 2: 0100h–017Fh
⋮	⋮	
0000 0000 1	111 1111	⋮
⋮	⋮	
0000 0001 0	000 0000	⋮
⋮	⋮	
0000 0001 0	111 1111	⋮
⋮	⋮	
⋮	⋮	⋮
⋮	⋮	
1111 1111 1	000 0000	Page 511: FF80h–FFFFh
⋮	⋮	
1111 1111 1	111 1111	

In addition to the data page, the processor must also know the particular word being referenced on that page. This is determined by a 7-bit offset (see Figure 6–3). The offset is supplied by the seven least significant bits (LSBs) of the instruction register, which holds the opcode for the next instruction to be executed. In direct addressing mode, the content of the instruction register has the format shown in Figure 6–4.

Figure 6–4. Instruction Register (IR) Contents in Direct Addressing Mode

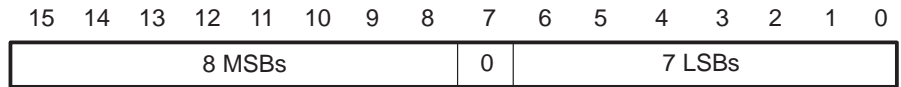

- 8 MSBs** Bits 15 through 8 indicate the instruction type (for example, ADD) and also contain any information regarding a shift of the data value to be accessed by the instruction.
- 0** **Direct/indirect indicator.** Bit 7 contains a 0 to define the addressing mode as direct.
- 7 LSBs** Bits 6 through 0 indicate the offset for the data-memory address referenced by the instruction.

To form a complete 16-bit address, the processor concatenates the DP value and the seven LSBs of the instruction register, as shown in Figure 6–5. The DP supplies the nine most significant bits (MSBs) of the address (the page number), and the seven LSBs of the instruction register supply the seven LSBs of the address (the offset). For example, to access data address 003Fh, you specify data page 0 (DP = 0000 0000 0) and an offset of 011 1111. Concatenating the DP and the offset produces the 16-bit address 0000 0000 0011 1111, which is 003Fh or decimal 63.

Figure 6–5. Generation of Data Addresses in Direct Addressing Mode

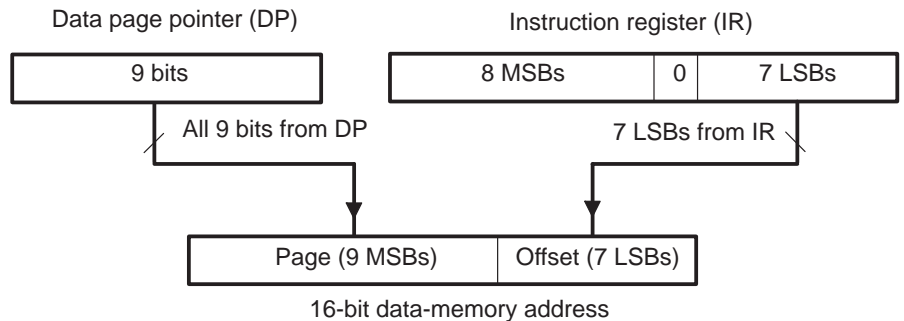

Initialize the DP in All Programs

It is critical that all programs initialize the DP. The DP is not initialized by reset and is undefined after power up. The 'C2xx development tools use default values for many parameters, including the DP. However, programs that do not explicitly initialize the DP can execute improperly, depending on whether they are executed on a 'C2xx device or with a development tool.

6.2.1 Using Direct Addressing Mode

When you use direct addressing mode, the processor uses the DP to find the data page and uses the seven LSBs of the instruction register to find a particular address on that page. Always do the following:

- 1) **Set the data page.** Load the appropriate value (from 0 to 511) into the DP. The DP register can be loaded by the LDP instruction or by any instruction that can load a value to ST0. The LDP instruction loads the DP directly without affecting the other bits of ST0, and it clearly indicates the value loaded into the DP. For example, to set the current data page to 32 (addresses 1000h–107Fh), you can use:

```
LDP #32      ;Initialize data page pointer
```

- 2) **Specify the offset.** Supply the 7-bit offset as an operand of the instruction. For example, if you want the ADD instruction to use the value at the second address of the current data page, you would write:

```
ADD 1h      ;Add to accumulator the value in the current  
            ;data page, offset of 1.
```

You do not have to set the data page prior to every instruction that uses direct addressing. If all the instructions in a block of code access the same data page, you can simply load the DP at the front of the block. However, if various data pages are being accessed throughout the block of code, be sure the DP is changed whenever a new data page should be accessed.

6.2.2 Examples of Direct Addressing

In Example 6–3, the first instruction loads the DP with 000000100_2 (4) to set the current data page to 4. The ADD instruction then references a data memory address that is generated as shown following the program code. Before the ADD instruction is executed, the opcode is loaded into the instruction register. Together, the DP and the seven LSBs of the instruction register form the complete 16-bit address, 0000001000001001_2 (0209h).

Example 6–3. Using Direct Addressing with ADD (Shift of 0 to 15)

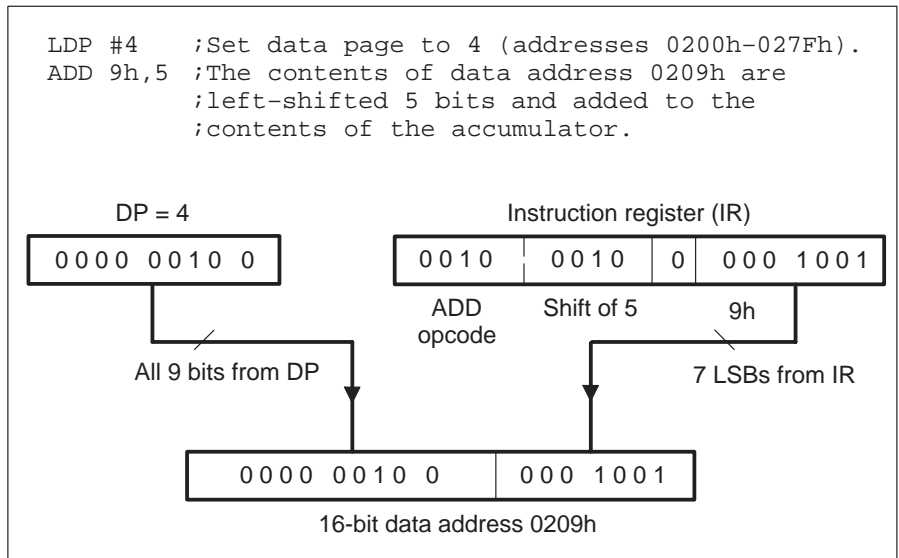

In Example 6–4, the ADD instruction references a data memory address that is generated as shown following the program code. For any instruction that performs a shift of 16, the shift value is not embedded directly in the instruction word; instead, all eight MSBs contain an opcode that not only indicates the instruction type but also a shift of 16. The eight MSBs of the instruction word indicate an ADD with a shift of 16.

Example 6–4. Using Direct Addressing with ADD (Shift of 16)

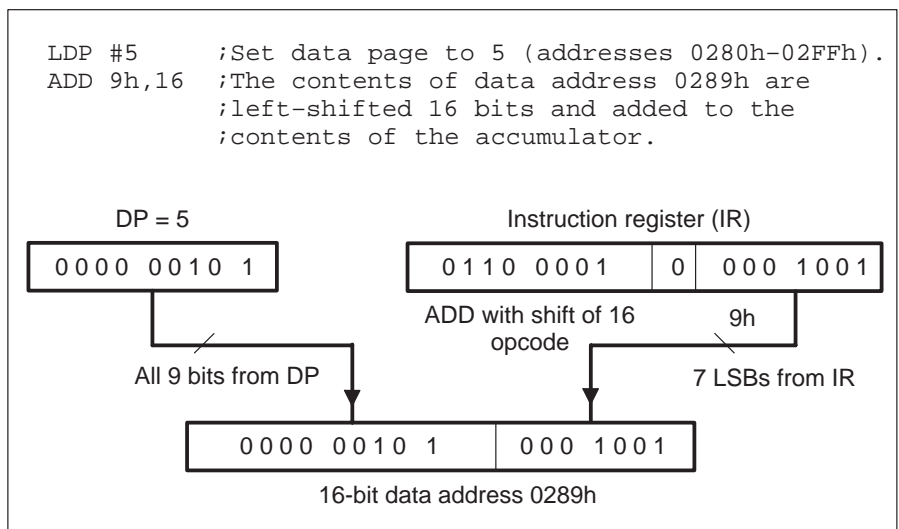

In Example 6–5, the ADDC instruction references a data memory address that is generated as shown following the program code. Note that if an instruction does not perform shifts, like the ADDC instruction does not, all eight MSBs of the instruction contain the opcode for the instruction type.

Example 6–5. Using Direct Addressing with ADDC

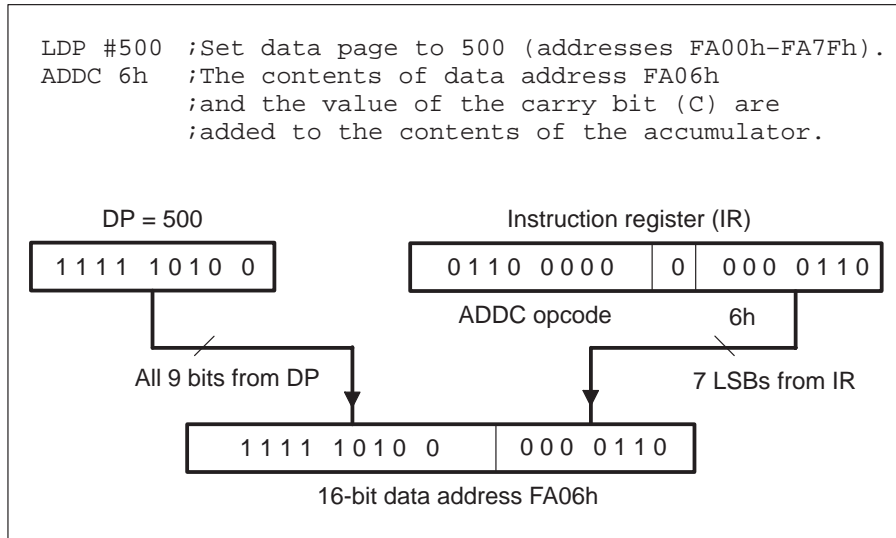

6.3 Indirect Addressing Mode

Eight auxiliary registers (AR0–AR7) provide flexible and powerful indirect addressing. Any location in the 64K data memory space can be accessed using a 16-bit address contained in an auxiliary register.

6.3.1 Current Auxiliary Register

To select a specific auxiliary register, load the 3-bit auxiliary register pointer (ARP) of status register ST0 with a value from 0 to 7. The ARP can be loaded as a primary operation by the MAR instruction or by the LST instruction. The ARP can be loaded as a secondary operation by any instruction that supports indirect addressing.

The register pointed to by the ARP is referred to as the *current auxiliary register* or *current AR*. During the processing of an instruction, the content of the current auxiliary register is used as the address at which the data-memory access will take place. The ARAU passes this address to the data-read address bus (DRAB) if the instruction requires a read from data memory, or it passes the address to the data-write address bus (DWAB) if the instruction requires a write to data memory. After the instruction uses the data value, the contents of the current auxiliary register can be incremented or decremented by the ARAU, which implements unsigned 16-bit arithmetic.

Normally, the ARAU performs its arithmetic operations in the decode phase of the pipeline (when the instruction specifying the operations is being decoded). This allows the address to be generated before the decode phase of the next instruction. There is an exception to this rule: During processing of the NORM instruction, the auxiliary register and/or ARP modification is done during the execute phase of the pipeline. For information on the operation of the pipeline, see Section 5.2 on page 5-7.

6.3.2 Indirect Addressing Options

The 'C2xx provides four types of indirect addressing options:

- No increment or decrement.** The instruction uses the content of the current auxiliary register as the data memory address but neither increments nor decrements the content of the current auxiliary register.
- Increment or decrement by 1.** The instruction uses the content of the current auxiliary register as the data memory address and then increments or decrements the content of the current auxiliary register by one.
- Increment or decrement by an index amount.** The value in AR0 is the index amount. The instruction uses the content of the current auxiliary reg-

ister as the data memory address and then increments or decrements the content of the current auxiliary register by the index amount.

- **Increment or decrement by an index amount using reverse carry.** The value in AR0 is the index amount. After the instruction uses the content of the current auxiliary register as the data-memory address, that content is incremented or decremented by the index amount. The addition or subtraction, in this case, is done with the carry propagation reversed (for FFTs).

These four option types provide the seven indirect addressing options listed in Table 6–1. The table also shows the instruction operand that corresponds to each indirect addressing option and gives an example of how each option is used.

Table 6–1. Indirect Addressing Operands

Option	Operand	Example
No increment or decrement	*	LT * loads the temporary register (TREG) with the content of the data memory address referenced by the current AR.
Increment by 1	*+	LT *+ loads the temporary register (TREG) with the content of the data memory address referenced by the current AR and then adds one to the content of the current AR.
Decrement by 1	*-	LT *- loads the temporary register (TREG) with the content of the data memory address referenced by the current AR and then subtracts one from the content of the current AR.
Increment by index amount	*0+	LT *0+ loads the temporary register (TREG) with the content of the data memory address referenced by the current AR and then adds the content of AR0 to the content of the current AR.
Decrement by index amount	*0-	LT *0- loads the temporary register (TREG) with the content of the data memory address referenced by the current AR and then subtracts the content of AR0 from the content of the current AR.

Table 6–1. Indirect Addressing Operands (Continued)

Option	Operand	Example
Increment by index amount, adding with reverse carry	*BR0+	LT *BR0+ loads the temporary register (TREG) with the content of the data memory address referenced by the current AR and then adds the content of AR0 to the content of the current AR, adding with reverse carry propagation.
Decrement by index amount, subtracting with reverse carry	*BR0–	LT *BR0– loads the temporary register (TREG) with the content of the data memory address referenced by the current AR and then subtracts the content of AR0 from the content of the current AR, subtracting with bit reverse carry propagation.

All increments or decrements are performed by the auxiliary register arithmetic unit (ARAU) in the same cycle during which the instruction is being decoded in the pipeline.

The bit-reversed indexed addressing allows efficient I/O operations by resequencing the data points in a radix-2 FFT program. The direction of carry propagation in the ARAU is reversed when the address is selected, and AR0 is added to or subtracted from the current auxiliary register. A typical use of this addressing mode requires that AR0 first be set to a value corresponding to half of the array's size, and that the current AR value be set to the base address of the data (the first data point).

6.3.3 Next Auxiliary Register

In addition to updating the current auxiliary register, a number of instructions can also specify the *next auxiliary register* or *next AR*. This register will be the current auxiliary register when the instruction execution is complete. The instructions that allow you to specify the next auxiliary register load the ARP with a new value. When the ARP is loaded with that value, the previous ARP value is loaded into the auxiliary register pointer buffer (ARB). Example 6–6 illustrates the selection of a next auxiliary register, as well as other indirect addressing features discussed so far.

Example 6–6. Selecting a New Current Auxiliary Register

```

MAR *,AR1      ;Load the ARP with 1 to make AR1 the
                ;current auxiliary register.
LT  **+,AR2    ;AR2 is the next auxiliary register.
                ;Load the TREG with the content of the
                ;address referenced by AR1, add one to
                ;the content of AR1, then make AR2 the
                ;current auxiliary register.
MPY *          ;Multiply TREG by content of address
                ;referenced by AR2.
    
```

6.3.4 Indirect Addressing Opcode Format

Figure 6–6 shows the format of the instruction word loaded into the instruction register when you use indirect addressing. The opcode fields are described following the figure.

Figure 6–6. Instruction Register Content in Indirect Addressing

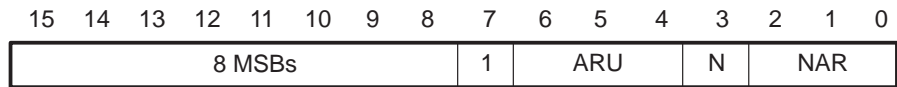

- 8 MSBs** Bits 15 through 8 indicate the instruction type (for example, LT) and also contain any information regarding data shifts.
- 1** **Direct/indirect indicator.** Bit 7 contains a 1 to define the addressing mode as indirect.
- ARU** **Auxiliary register update code.** Bits 6 through 4 determine whether and how the current auxiliary register is incremented or decremented. See Table 6–2.

Table 6–2. Effects of the ARU Code on the Current Auxiliary Register

ARU Code			Arithmetic Operation Performed on Current AR
6	5	4	
0	0	0	No operation on current AR
0	0	1	current AR – 1 → current AR
0	1	0	current AR + 1 → current AR
0	1	1	Reserved
1	0	0	current AR – AR0 → current AR [reverse carry propagation]
1	0	1	current AR – AR0 → current AR
1	1	0	current AR + AR0 → current AR
1	1	1	current AR + AR0 → current AR [reverse carry propagation]

N **Next auxiliary register indicator.** Bit 3 specifies whether the instruction will change the ARP value.

N = 0 If N is 0, the content of the ARP will remain unchanged.

N = 1 If N is 1, the content of NAR will be loaded into the ARP, and the old ARP value is loaded into the auxiliary register buffer (ARB) of status register ST1.

NAR **Next auxiliary register value.** Bits 2 through 0 contain the value of the next auxiliary register. NAR is loaded into the ARP if N = 1.

Table 6–3 shows the opcode field bits and the notation used for indirect addressing. It also shows the corresponding operations performed on the current auxiliary register and the ARP.

Table 6–3. Field Bits and Notation for Indirect Addressing

Instruction Opcode Bits										Operand(s)	Operation
15	–	8	7	6	5	4	3	2	1		
←	8 MSBs	→	1	0	0	0	0	0	←NAR→	*	No manipulation of current AR
←	8 MSBs	→	1	0	0	0	0	1	←NAR→	*,AR n	NAR → ARP
←	8 MSBs	→	1	0	0	1	0	0	←NAR→	*–	current AR – 1 → current AR
←	8 MSBs	→	1	0	0	1	1	0	←NAR→	*–,AR n	current AR – 1 → current AR NAR → ARP
←	8 MSBs	→	1	0	1	0	0	0	←NAR→	*+	current AR + 1 → current AR
←	8 MSBs	→	1	0	1	0	1	0	←NAR→	*+,AR n	current AR + 1 → current AR NAR → ARP
←	8 MSBs	→	1	1	0	0	0	0	←NAR→	*BR0–	current AR – rcAR0 → current AR †
←	8 MSBs	→	1	1	0	0	1	0	←NAR→	*BR0–,AR n	current AR – rcAR0 → current AR NAR → ARP †
←	8 MSBs	→	1	1	0	1	0	0	←NAR→	*0–	current AR – AR0 → current AR
←	8 MSBs	→	1	1	0	1	1	0	←NAR→	*0–,AR n	current AR – AR0 → current AR NAR → ARP
←	8 MSBs	→	1	1	1	0	0	0	←NAR→	*0+	current AR + AR0 → current AR
←	8 MSBs	→	1	1	1	0	1	0	←NAR→	*0+,AR n	current AR + AR0 → current AR NAR → ARP
←	8 MSBs	→	1	1	1	1	0	0	←NAR→	*BR0+	current AR + rcAR0 → current AR †
←	8 MSBs	→	1	1	1	1	1	0	←NAR→	*BR0+,AR n	current AR + rcAR0 → current AR NAR → ARP †

† Bit-reversed addressing mode

Legend:

- rc Reverse carry propagation
- NAR Next AR
- n 0, 1, 2, ..., or 7
- 8 MSBs Eight bits determined by instruction type and (sometimes) shift information
- Is loaded into

Example 6–9. Decrement by 1

```
ADD *- ,8 ;Operates as in Example 6-7, but in
;addition, the current auxiliary register
;is decremented by one.
```

Example 6–10. Increment by Index Amount

```
ADD *0+,8 ;Operates as in Example 6-7, but in
;addition, the content of register AR0
;is added to the current auxiliary
;register.
```

Example 6–11. Decrement by Index Amount

```
ADD *0-,8 ;Operates as in Example 6-7, but in
;addition, the content of register AR0
;is subtracted from the current auxiliary
;register.
```

Example 6–12. Increment by Index Amount With Reverse Carry Propagation

```
ADD *BR0+,8 ;Operates as in Example 6-10, except that
;the content of register AR0 is added to
;the current auxiliary register with
;reverse carry propagation.
```

Example 6–13. Decrement by Index Amount With Reverse Carry Propagation

```
ADD *BR0-,8 ;Operates as in Example 6-11, except that
;the content of register AR0 is subtracted
;from the current auxiliary register with
;reverse carry propagation.
```

6.3.6 Modifying Auxiliary Register Content

The LAR, ADRK, SBRK, and MAR instructions are specialized instructions for changing the content of an auxiliary register (AR):

- The LAR instruction loads an AR.
- The ADRK instruction adds an immediate value to an AR; SBRK subtracts an immediate value.
- The MAR instruction can increment or decrement an AR value by one or by an index amount.

However, you are not limited to these four instructions. Auxiliary registers can be modified by any instruction that supports indirect addressing operands. (Indirect addressing can be used with all instructions except those that have immediate operands or no operands.)

Assembly Language Instructions

The 'C2xx instruction set supports numerically intensive signal-processing operations as well as general-purpose applications such as multiprocessing and high-speed control. The 'C2xx instruction set is compatible with the 'C2x instruction set; code written for the 'C2x can be reassembled to run on the 'C2xx. The 'C5x instruction set is a superset of that of the 'C2xx; thus, code written for the 'C2xx can be upgraded to run on a 'C5x.

This chapter describes the assembly language instructions.

Topic	Page
7.1 Instruction Set Summary	7-2
7.2 How To Use the Instruction Descriptions	7-12
7.3 Instruction Descriptions	7-20

7.1 Instruction Set Summary

This section provides a summary of the instruction set in six tables (Table 7–1 to Table 7–6) according to the following functional headings:

- Accumulator, arithmetic, and logic instructions (see Table 7–1 on page 7-4)
- Auxiliary register and data page pointer instructions (see Table 7–2 on page 7-7)
- TREG, PREG, and multiply instructions (see Table 7–3 on page 7-7)
- Branch instructions (see Table 7–4 on page 7-8)
- Control instructions (see Table 7–5 on page 7-9)
- I/O and memory operations (see Table 7–6 on page 7-10)

Within each table, the instructions are arranged alphabetically. The number of words that an instruction occupies in program memory is specified in column three of each table; the number of cycles that an instruction requires to execute is in column four. All instructions are assumed to be executed from internal program memory (RAM) and internal data dual-access memory. The cycle timings are for single-instruction execution, not for repeat mode. Additional information about each instruction is presented in the individual instruction descriptions in Section 7.2.

For your reference, here are definitions of the symbols used in these six summary tables:

ACC	The accumulator
AR	Auxiliary register
ARX	A 3-bit value used in the LAR and SAR instructions to designate which auxiliary register will be loaded (LAR) or have its contents stored (SAR)
BITX	A 4-bit value (called the bit code) that determines which bit of a designated data memory value will be tested by the BIT instruction
CM	A 2-bit value. The CMPR instruction performs a comparison specified by the value of CM: If CM = 00, test whether current AR = AR0 If CM = 01, test whether current AR < AR0 If CM = 10, test whether current AR > AR0 If CM = 11, test whether current AR ≠ AR0

I AAA AAAA	(One I followed by seven As) The I at the left represents a bit that reflects whether direct addressing (I = 0) or indirect addressing (I = 1) is being used. When direct addressing is used, the seven As are the seven least significant bits (LSBs) of a data memory address. For indirect addressing, the seven As are bits that control auxiliary register manipulation (see Section 6.3, <i>Indirect Addressing Mode</i> , p. 6-9).								
IIII IIII	(Eight Is) An 8-bit constant used in short immediate addressing								
I IIII IIII	(Nine Is) A 9-bit constant used in short immediate addressing for the LDP instruction								
I IIII IIII IIII	(Thirteen Is) A 13-bit constant used in short immediate addressing for the MPY instruction								
I INTR#	A 5-bit value representing a number from 0 to 31. The INTR instruction uses this number to change program control to one of the 32 interrupt vector addresses.								
PM	A 2-bit value copied into the PM bits of status register ST1 by the SPM instruction								
SHF	A 3-bit left-shift value								
SHFT	A 4-bit left-shift value								
TP	A 2-bit value used by the conditional execution instructions to represent four conditions:								
	<table> <tr> <td>$\overline{\text{BIO}}$ pin low</td> <td>TP = 00</td> </tr> <tr> <td>TC bit = 1</td> <td>TP = 01</td> </tr> <tr> <td>TC bit = 0</td> <td>TP = 10</td> </tr> <tr> <td>No condition</td> <td>TP = 11</td> </tr> </table>	$\overline{\text{BIO}}$ pin low	TP = 00	TC bit = 1	TP = 01	TC bit = 0	TP = 10	No condition	TP = 11
$\overline{\text{BIO}}$ pin low	TP = 00								
TC bit = 1	TP = 01								
TC bit = 0	TP = 10								
No condition	TP = 11								

ZLVC ZLVC Two 4-bit fields — each representing the following conditions:

ACC = 0	Z
ACC < 0	L
Overflow	V
Carry	C

A conditional instruction contains two of these 4-bit fields. The 4-LSB field of the instruction is a mask field. A 1 in the corresponding mask bit indicates that condition is being tested. For example, to test for $ACC \geq 0$, the Z and L fields are set, and the V and C fields are not set. The Z field is set to test the condition $ACC = 0$, and the L field is reset to test the condition $ACC \geq 0$. The second 4-bit field (bits 4 – 7) indicates the state of the conditions to test. The conditions possible with these eight bits are shown in the descriptions for the BCND, CC, and RETC instructions.

+ 1 word The second word of a two-word opcode. This second word contains a 16-bit constant. Depending on the instruction, this constant is a long immediate value, a program memory address, or an address for an I/O port or an I/O-mapped register.

Table 7–1. Accumulator, Arithmetic, and Logic Instructions

Mnemonic	Description	Words	Cycles	Opcode
ABS	Absolute value of ACC	1	1	1011 1110 0000 0000
ADD	Add to ACC with shift of 0 to 15, direct or indirect	1	1	0010 SHFT IAAA AAAA
	Add to ACC with shift 0 to 15, long immediate	2	2	1011 1111 1001 SHFT + 1 word
	Add to ACC with shift of 16, direct or indirect	1	1	0110 0001 IAAA AAAA
	Add to ACC, short immediate	1	1	1011 1000 IIII IIII
ADDC	Add to ACC with carry, direct or indirect	1	1	0110 0000 IAAA AAAA
ADDS	Add to low ACC with sign-extension suppressed, direct or indirect	1	1	0110 0010 IAAA AAAA
ADDT	Add to ACC with shift (0 to 15) specified by TREG, direct or indirect	1	1	0110 0011 IAAA AAAA

Table 7-1. Accumulator, Arithmetic, and Logic Instructions (Continued)

Mnemonic	Description	Words	Cycles	Opcode
AND	AND ACC with data value, direct or indirect	1	1	0110 1110 IAAA AAAA
	AND with ACC with shift of 0 to 15, long immediate	2	2	1011 1111 1011 SHFT + 1 word
	AND with ACC with shift of 16, long immediate	2	2	1011 1110 1000 0001 + 1 word
CMPL	Complement ACC	1	1	1011 1110 0000 0001
LACC	Load ACC with shift of 0 to 15, direct or indirect	1	1	0001 SHFT IAAA AAAA
	Load ACC with shift of 0 to 15, long immediate	2	2	1011 1111 1000 SHFT + 1 word
	Load ACC with shift of 16, direct or indirect	1	1	0110 1010 IAAA AAAA
LACL	Load low word of ACC, direct or indirect	1	1	0110 1001 IAAA AAAA
	Load low word of ACC, short immediate	1	1	1011 1001 IIII IIII
LACT	Load ACC with shift (0 to 15) specified by TREG, direct or indirect	1	1	0110 1011 IAAA AAAA
NEG	Negate ACC	1	1	1011 1110 0000 0010
NORM	Normalize the contents of ACC, indirect	1	1	1010 0000 IAAA AAAA
OR	OR ACC with data value, direct or indirect	1	1	0110 1101 IAAA AAAA
	OR with ACC with shift of 0 to 15, long immediate	2	2	1011 1111 1100 SHFT + 1 word
	OR with ACC with shift of 16, long immediate	2	2	1011 1110 1000 0010 + 1 word
ROL	Rotate ACC left	1	1	1011 1110 0000 1100
ROR	Rotate ACC right	1	1	1011 1110 0000 1101
SACH	Store high ACC with shift of 0 to 7, direct or indirect	1	1	1001 1SHF IAAA AAAA
SACL	Store low ACC with shift of 0 to 7, direct or indirect	1	1	1001 0SHF IAAA AAAA
SFL	Shift ACC left	1	1	1011 1110 0000 1001
SFR	Shift ACC right	1	1	1011 1110 0000 1010

Table 7–1. Accumulator, Arithmetic, and Logic Instructions (Continued)

Mnemonic	Description	Words	Cycles	Opcode
SUB	Subtract from ACC with shift of 0 to 15, direct or indirect	1	1	0011 SHFT IAAA AAAA
	Subtract from ACC with shift of 0 to 15, long immediate	2	2	1011 1111 1010 SHFT + 1 word
	Subtract from ACC with shift of 16, direct or indirect	1	1	0110 0101 IAAA AAAA
	Subtract from ACC, short immediate	1	1	1011 1010 IIII IIII
SUBB	Subtract from ACC with borrow, direct or indirect	1	1	0110 0100 IAAA AAAA
SUBC	Conditional subtract, direct or indirect	1	1	0000 1010 IAAA AAAA
SUBS	Subtract from ACC with sign-extension suppressed, direct or indirect	1	1	0110 0110 IAAA AAAA
SUBT	Subtract from ACC with shift (0 to 15) specified by TREG, direct or indirect	1	1	0110 0111 IAAA AAAA
XOR	Exclusive OR ACC with data value, direct or indirect	1	1	0110 1100 IAAA AAAA
	Exclusive OR with ACC with shift of 0 to 15, long immediate	2	2	1011 1111 1101 SHFT + 1 word
	Exclusive OR with ACC with shift of 16, long immediate	2	2	1011 1110 1000 0011 + 1 word
ZALR	Zero low ACC and load high ACC with rounding, direct or indirect	1	1	0110 1000 IAAA AAAA

Table 7–2. Auxiliary Register Instructions

Mnemonic	Description	Words	Cycles	Opcode
ADRK	Add constant to current AR, short immediate	1	1	0111 1000 IIII IIII
BANZ	Branch on current AR not-zero, indirect	2	4 (condition true) 2 (condition false)	0111 1011 1AAA AAAA + 1 word
CMPR	Compare current AR with ARO	1	1	1011 1111 0100 01CM
LAR	Load specified AR from specified data location, direct or indirect	1	2	0000 0ARX IAAA AAAA
	Load specified AR with constant, short immediate	1	2	1011 0ARX IIII IIII
	Load specified AR with constant, long immediate	2	2	1011 1111 0000 1ARX + 1 word
MAR	Modify current AR and/or ARP, indirect (performs no operation when direct)	1	1	1000 1011 IAAA AAAA
SAR	Store specified AR to specified data location, direct or indirect	1	1	1000 0ARX IAAA AAAA
SBRK	Subtract constant from current AR, short immediate	1	1	0111 1100 IIII IIII

Table 7–3. TREG, PREG, and Multiply Instructions

Mnemonic	Description	Words	Cycles	Opcode
APAC	Add PREG to ACC	1	1	1011 1110 0000 0100
LPH	Load high PREG, direct or indirect	1	1	0111 0101 IAAA AAAA
LT	Load TREG, direct or indirect	1	1	0111 0011 IAAA AAAA
LTA	Load TREG and accumulate previous product, direct or indirect	1	1	0111 0000 IAAA AAAA
LTD	Load TREG, accumulate previous product, and move data, direct or indirect	1	1	0111 0010 IAAA AAAA
LTP	Load TREG and store PREG in accumulator, direct or indirect	1	1	0111 0001 IAAA AAAA
LTS	Load TREG and subtract previous product, direct or indirect	1	1	0111 0100 IAAA AAAA

Table 7–3. TREG, PREG, and Multiply Instructions (Continued)

Mnemonic	Description	Words	Cycles	Opcode
MAC	Multiply and accumulate, direct or indirect	2	3	1010 0010 IAAA AAAA + 1 word
MACD	Multiply and accumulate with data move, direct or indirect	2	3	1010 0011 IAAA AAAA + 1 word
MPY	Multiply TREG by data value, direct or indirect	1	1	0101 0100 IAAA AAAA
	Multiply TREG by 13-bit constant, short immediate	1	1	110I IIII IIII IIII
MPYA	Multiply and accumulate previous product, direct or indirect	1	1	0101 0000 IAAA AAAA
MPYS	Multiply and subtract previous product, direct or indirect	1	1	0101 0001 IAAA AAAA
MPYU	Multiply unsigned, direct or indirect	1	1	0101 0101 IAAA AAAA
PAC	Load ACC with PREG	1	1	1011 1110 0000 0011
SPAC	Subtract PREG from ACC	1	1	1011 1110 0000 0101
SPH	Store high PREG, direct or indirect	1	1	1000 1101 IAAA AAAA
SPL	Store low PREG, direct or indirect	1	1	1000 1100 IAAA AAAA
SPM	Set product shift mode	1	1	1011 1111 0000 00PM
SQRA	Square and accumulate previous product, direct or indirect	1	1	0101 0010 IAAA AAAA
SQRS	Square and subtract previous product, direct or indirect	1	1	0101 0011 IAAA AAAA

Table 7–4. Branch Instructions

Mnemonic	Description	Words	Cycles	Opcode
B	Branch unconditionally, indirect	2	4	0111 1001 1AAA AAAA + 1 word
BACC	Branch to address specified by ACC	1	4	1011 1110 0010 0000
BANZ	Branch on current AR not-zero, indirect	2	4 (condition true) 2 (condition false)	0111 1011 1AAA AAAA + 1 word
BCND	Branch conditionally	2	4 (conditions true) 2 (any condition false)	1110 00TP ZLVC ZLVC + 1 word
CALA	Call subroutine at location specified by ACC	1	4	1011 1110 0011 0000

Table 7–4. Branch Instructions (Continued)

Mnemonic	Description	Words	Cycles	Opcode
CALL	Call subroutine, indirect	2	4	0111 1010 1AAA AAAA + 1 word
CC	Call conditionally	2	4 (conditions true) 2 (any condition false)	1110 10TP ZLVC ZLVC + 1 word
INTR	Soft interrupt	1	4	1011 1110 0111 NTR#
NMI	Nonmaskable interrupt	1	4	1011 1110 0101 0010
RET	Return from subroutine	1	4	1110 1111 0000 0000
RETC	Return conditionally	1	4 (conditions true) 2 (any condition false)	1110 11TP ZLVC ZLVC
TRAP	Software interrupt	1	4	1011 1110 0101 0001

Table 7–5. Control Instructions

Mnemonic	Description	Words	Cycles	Opcode
BIT	Test bit, direct or indirect	1	1	0100 BITX IAAA AAAA
BITT	Test bit specified by TREG, direct or indirect	1	1	0110 1111 IAAA AAAA
CLRC	Clear C bit	1	1	1011 1110 0100 1110
	Clear CNF bit	1	1	1011 1110 0100 0100
	Clear INTM bit	1	1	1011 1110 0100 0000
	Clear OVM bit	1	1	1011 1110 0100 0010
	Clear SXM bit	1	1	1011 1110 0100 0110
	Clear TC bit	1	1	1011 1110 0100 1010
	Clear XF bit	1	1	1011 1110 0100 1100
IDLE	Idle until interrupt	1	1	1011 1110 0010 0010
LDP	Load data page pointer, direct or indirect	1	2	0000 1101 IAAA AAAA
	Load data page pointer, short immediate	1	2	1011 110I IIII IIII
LST	Load status register ST0, direct or indirect	1	2	0000 1110 IAAA AAAA
	Load status register ST1, direct or indirect	1	2	0000 1111 IAAA AAAA
NOP	No operation	1	1	1000 1011 0000 0000
POP	Pop top of stack to low ACC	1	1	1011 1110 0011 0010

Table 7–5. Control Instructions (Continued)

Mnemonic	Description	Words	Cycles	Opcode
POPD	Pop top of stack to data memory, direct or indirect	1	1	1000 1010 IAAA AAAA
PSHD	Push data memory value on stack, direct or indirect	1	1	0111 0110 IAAA AAAA
PUSH	Push low ACC onto stack	1	1	1011 1110 0011 1100
RPT	Repeat next instruction, direct or indirect	1	1	0000 1011 IAAA AAAA
	Repeat next instruction, short immediate	1	1	1011 1011 IIII IIII
SETC	Set C bit	1	1	1011 1110 0100 1111
	Set CNF bit	1	1	1011 1110 0100 0101
	Set INTM bit	1	1	1011 1110 0100 0001
	Set OVM bit	1	1	1011 1110 0100 0011
	Set SXM bit	1	1	1011 1110 0100 0111
	Set TC bit	1	1	1011 1110 0100 1011
	Set XF bit	1	1	1011 1110 0100 1101
SPM	Set product shift mode	1	1	1011 1111 0000 00PM
SST	Store status register ST0, direct or indirect	1	1	1000 1110 IAAA AAAA
	Store status register ST1, direct or indirect	1	1	1000 1111 IAAA AAAA

Table 7–6. I/O and Memory Instructions

Mnemonic	Description	Words	Cycles	Opcode
BLDD	Block move from data memory to data memory, direct/indirect with long immediate source	2	3	1010 1000 IAAA AAAA + 1 word
	Block move from data memory to data memory, direct/indirect with long immediate destination	2	3	1010 1001 IAAA AAAA + 1 word
BLPD	Block move from program memory to data memory, direct/indirect with long immediate source	2	3	1010 0101 IAAA AAAA + 1 word
DMOV	Data move in data memory, direct or indirect	1	1	0111 0111 IAAA AAAA
IN	Input data from I/O location, direct or indirect	2	2	1010 1111 IAAA AAAA + 1 word
OUT	Output data to port, direct or indirect	2	3	0000 1100 IAAA AAAA + 1 word
SPLK	Store long immediate to data memory location, direct or indirect	2	2	1010 1110 IAAA AAAA + 1 word

Table 7–6. I/O and Memory Instructions (Continued)

Mnemonic	Description	Words	Cycles	Opcode
TBLR	Table read, direct or indirect	1	3	1010 0110 IAAA AAAA
TBLW	Table write, direct or indirect	1	3	1010 0111 IAAA AAAA

7.2 How To Use the Instruction Descriptions

Section 7.3 contains detailed information on the instruction set. The description for each instruction presents the following categories of information:

- Syntax
- Operands
- Opcode
- Execution
- Status Bits
- Description
- Words
- Cycles
- Examples

7.2.1 Syntax

Each instruction begins with a list of the available assembler syntax expressions and the addressing mode type(s) for each expression. For example, the description for the ADD instruction begins with:

ADD <i>dma</i> [, <i>shift</i>]	Direct addressing
ADD <i>dma</i> , 16	Direct with left shift of 16
ADD <i>ind</i> [, <i>shift</i> [, AR <i>n</i>]]	Indirect addressing
ADD <i>ind</i> , 16 [, AR <i>n</i>]	Indirect with left shift of 16
ADD # <i>k</i>	Short immediate addressing
ADD # <i>lk</i> [, <i>shift</i>]	Long immediate addressing

These are the notations used in the syntax expressions:

italic symbols Italic symbols in an instruction syntax represent variables.

Example: For the syntax:
ADD *dma*
 you may use a variety of values for *dma*.
 Samples with this syntax follow:

```
ADD DAT
ADD 15
```

boldface characters Boldface characters in an instruction syntax must be typed as shown.

Example: For the syntax:
ADD *dma*, 16
 you may use a variety of values for *dma*, but the word ADD and the number 16 should be typed as shown. Samples with this syntax follow:

```
ADD 7h, 16
ADD X, 16
```

- [, x] Operand x is optional.
Example: For the syntax:
 ADD dma, [, *shift*]
 you must supply *dma*, as in the instruction:
 `ADD 7h`
 and you have the option of adding a *shift* value,
 as in the instruction:
 `ADD 7h, 5`
- [, x1 [, x2]] Operands x1 and x2 are optional, but you cannot include x2
 without also including x1.
Example: For the syntax:
 ADD ind, [, *shift* [, **ARn**]]
 you must supply *ind*, as in the instruction:
 `ADD *+`
 You have the option of including *shift*,
 as in the instruction:
 `ADD *+, 5`
 If you wish to include **ARn**, you must also
 include *shift*, as in:
 `ADD *+, 0, AR2`
- # The # symbol is a prefix for constants used in immediate
 addressing. For short- or long- immediate operands, it is
 used in instructions where there is ambiguity with other
 addressing modes.
Example: `RPT #15` uses short immediate addressing. It
 causes the next instruction to be repeated 16
 times. But `RPT 15` uses direct addressing.
 The number of times the next instruction
 repeats is determined by a value stored in
 memory.

Finally, consider this code example:

```
MoveData BLDD DAT5, #310h ;move data at address
                           ;referenced by DAT5 to address
                           ;310h.
```

Note the optional label `MoveData` used as a reference in front of the instruction mnemonic. Place labels either before the instruction mnemonic on the same line or on the preceding line in the first column. (Be sure there are no spaces in your labels.) An optional comment field can conclude the syntax expression. At least one space is required between fields (label, mnemonic, operand, and comment).

7.2.2 Operands

Operands can be constants, or assembly-time expressions referring to memory, I/O ports, register addresses, pointers, shift counts, and a variety of other constants. The operands category for each instruction description defines the variables used for and/or within operands in the syntax expressions. For example, for the ADD instruction, the syntax category gives these syntax expressions:

ADD <i>dma</i> [, <i>shift</i>]	Direct addressing
ADD <i>dma</i> , 16	Direct with left shift of 16
ADD <i>ind</i> [, <i>shift</i> [, AR <i>n</i>]]	Indirect addressing
ADD <i>ind</i> , 16 [, AR <i>n</i>]	Indirect with left shift of 16
ADD # <i>k</i>	Short immediate addressing
ADD # <i>lk</i> [, <i>shift</i>]	Long immediate addressing

The operands category defines the variables *dma*, *shift*, *ind*, *n*, *k*, and *lk*. For *ind*, an indirect addressing variable, you supply one of the following seven symbols:

* *+ *− *0+ *0− *BR0+ *BR0−

These symbols are defined in subsection 6.3.2, *Indirect Addressing Options*, on page 6-9.

7.2.3 Opcode

The opcode category breaks down the various bit fields that make up each instruction word. When one of the fields contains a constant value derived directly from an operand, it will have the same name as that operand. The contents of fields that do not directly relate to operands are given other names; the opcode category either explains these names directly or refers you to a section of this book that explains them in detail. For example, these opcodes are given for the ADDC instruction:

ADDC *dma*

15	14	13	12	11	10	9	8	7	6	5	4	3	2	1	0
0	1	1	0	0	0	0	0	0	dma						

ADDC *ind* [, **AR***n*]

15	14	13	12	11	10	9	8	7	6	5	4	3	2	1	0
0	1	1	0	0	0	0	0	1	ARU	N	NAR				

Note: ARU, N, and NAR are defined in Section 6.3, *Indirect Addressing Mode* (page 6-9).

The field called *dma* contains the value *dma*, which is defined in the operands category. The contents of the fields ARU, N, and NAR are derived from the operands *ind* and *n* but do not directly correspond to those operands; therefore, a note directs you to the appropriate section for more details.

7.2.4 Execution

The execution category presents an instruction operation sequence that describes the processing that takes place when the instruction is executed. If the execution event or events depend on the addressing mode used, the execution category specifies which events are associated with which addressing modes. Here are notations used in the execution category:

(r)	The content of register or location r. <i>Example:</i> (ACC) represents the value in the accumulator.
$x \rightarrow y$	Value x is assigned to register or location y. <i>Example:</i> (data-memory address) \rightarrow ACC means: The content of the specified data-memory address is put into the accumulator.
r(n:m)	Bits n through m of register or location r. <i>Example:</i> ACC(15:0) represents bits 15 through 0 of the accumulator.
(r(n:m))	The content of bits n through m of register or location r. <i>Example:</i> (ACC(31:16)) represents the content of bits 31 through 16 of the accumulator.
nnh	Indicates that nn represents a hexadecimal number.

7.2.5 Status Bits

The bits in status registers ST0 and ST1 affect the operation of certain instructions and are affected by certain instructions. The status bits category of each instruction description states which of the bits (if any) affect the execution of the instruction and which of the bits (if any) are affected by the instruction.

7.2.6 Description

The description category explains what happens during instruction execution and its effect on the rest of the processor or on memory contents. It also discusses any constraints on the operands imposed by the processor or the assembler. This description parallels and supplements the information given in the execution category.

7.2.7 Words

The words category specifies the number of memory words (one or two) required to store the instruction. When the number of words depends on the addressing mode used for an instruction, the words category specifies which addressing modes require one word and which require two words.

7.2.8 Cycles

The cycles category of each instruction description contains tables showing the number of processor machine cycles (CLKOUT1 periods) required for the instruction to execute in a given memory configuration when executed as a single instruction or when repeated with the RPT instruction. For example:

Cycles for a Single Instruction

Operand	Program			
	ROM	DARAM	SARAM	External
DARAM	1	1	1	1+p
SARAM	1	1	1	1+p
External	1+d	1+d	1+d	2+d+p

Cycles for a Repeat (RPT) Execution of an Instruction

Operand	Program			
	ROM	DARAM	SARAM	External
DARAM	n	n	n	n+p
SARAM	n	n	n	n+p
External	n+nd	n+nd	n+nd	n+1+p+nd

The column headings in these tables indicate the program source location, defined as follows:

- ROM** The instruction executes from internal program ROM.
- DARAM** The instruction executes from internal dual-access program RAM.
- SARAM** The instruction executes from internal single-access program RAM.
- External** The instruction executes from external program memory.

If an instruction requires memory operand(s), the rows in the table indicate the location(s) of the operand(s), as defined here:

DARAM The operand is in internal dual-access RAM.

SARAM The operand is in internal single-access RAM.

External The operand is in external memory.

For the RPT mode execution, n indicates the number of times a given instruction is repeated by an RPT instruction. Additional cycles (wait states) can be generated for program-memory, data-memory, and I/O accesses by the wait-state generator or by the external READY signal. These additional wait states are represented in the tables by the following variables:

- p** Program-memory wait states. Represents the number of additional clock cycles the device waits for external program memory to respond to a single access.
- d** Data-memory wait states. Represents the number of additional clock cycles the device waits for external data memory to respond to a single access.
- io** I/O wait states. Represents the number of additional clock cycles the device waits for an external I/O device to respond to a single access.
- n** Number of repetitions (where $n > 2$ to fill the pipeline). Represents the number of times a repeated instruction is executed.

If there are multiple accesses to one of the spaces, the variable will be preceded by the appropriate integer multiple. For example, two accesses to external program memory would require $2p$ wait states. The above variables may also use the subscripts *src*, *dst*, and *code* to indicate source, destination, and code, respectively.

The internal single-access memory on each 'C2xx processor is divided into 2K-word blocks contiguous in address space. All 'C2xx processors support parallel accesses to these internal single-access RAM blocks. Furthermore, one single access block allows only one access per cycle. Thus, the processor can read/write on single-access RAM block while accessing another single-access RAM block at the same time.

All external reads take at least one machine cycle while all external writes take at least two machine cycles. However, if an external write is immediately followed or preceded by an external read cycle, then the external write requires three cycles. If the wait state generator or the READY pin is used to add m ($m > 0$) wait states to an external access, then external reads require $m+1$ cycles, and external write accesses require $m+2$ cycles. See Section 8.5, *Wait-State Generator*, page 8-14, for the discussion on generating wait states.

The instruction-cycle timings are based on the following assumptions:

- At least the next four instructions are fetched from the same memory section (internal or external) that was used to fetch the current instruction (except in the case of PC discontinuity instructions, such as B, CALL, etc.)
- In the single-execution mode, there is no pipeline conflict between the current instruction and the instructions immediately preceding or following that instruction. The only exception is the conflict between the fetch phase of the pipeline and the memory read/write (if any) access of the instruction under consideration. See Section 5.2, *Pipeline*, on page 5-7 for more information about pipeline operation.
- In the repeat execution mode, all conflicts caused by the pipelined execution of an instruction are considered.

7.2.9 Examples

Example code is included for each instruction. The effect of the code on memory and/or registers is summarized. Program code is shown in a special typeface. The sample code is then followed by a verbal or graphic description of the effect of that code. Consider this example of the ADD instruction:

ADD *, 0, AR0

		Before Instruction			After Instruction
ARP		4	ARP		0
AR4		0302h	AR4		0303h
Data Memory			Data Memory		
302h		2h	302h		2h
ACC	X	2h	ACC	0	04h
	C			C	

Here are the facts and events represented in this example:

- The auxiliary register pointer (ARP) points to the current auxiliary register. Because ARP = 4, the current auxiliary register is AR4.
- When the addition takes place, the CPU follows AR4 to data-memory address 0302h. The content of that address, 2h, is added to the content of the accumulator, also 2h. The result (4h) is placed in the accumulator. (Because the second operand of the instruction specifies a left shift of 0, the data-memory value is not shifted before being added to the accumulator value.)
- The instruction specifies an increment of one for the contents of the current auxiliary register (*+); therefore, after the addition is performed, the content of AR4 is incremented to 0303h.

- The instruction also specifies that AR0 will be the next auxiliary register; therefore, after the instruction $ARP = 0$.
- Because no carry is generated during the addition, the carry bit (C) becomes 0.

7.3 Instruction Descriptions

This section contains detailed information on the instruction set for the 'C2xx (For a summary of the instruction set, see Section 7.1.) The instructions are presented alphabetically, and the description for each instruction presents the following categories of information:

- Syntax
- Operands
- Opcode
- Execution
- Status Bits
- Description
- Words
- Cycles
- Examples

For a description of how to use each of these categories, see Section 7.2.

Example 1

ABS

		Before Instruction			After Instruction
ACC	<input checked="" type="checkbox"/> C	1234h	ACC	<input type="checkbox"/> C	1234h

Example 2

ABS

		Before Instruction			After Instruction
ACC	<input checked="" type="checkbox"/> C	0FFFFFFFh	ACC	<input type="checkbox"/> C	1h

Example 3

ABS

; (OVM = 1)

		Before Instruction			After Instruction
ACC	<input checked="" type="checkbox"/> C	80000000h	ACC	<input type="checkbox"/> C	7FFFFFFFh
	<input checked="" type="checkbox"/> OV			<input type="checkbox"/> OV	

Example 4

ABS

; (OVM = 0)

		Before Instruction			After Instruction
ACC	<input checked="" type="checkbox"/> C	80000000h	ACC	<input type="checkbox"/> C	80000000h
	<input checked="" type="checkbox"/> OV			<input type="checkbox"/> OV	

Syntax	ADD <i>dma</i> [, <i>shift</i>]	Direct addressing
	ADD <i>dma</i> , 16	Direct with left shift of 16
	ADD <i>ind</i> [, <i>shift</i> [, AR <i>n</i>]]	Indirect addressing
	ADD <i>ind</i> , 16 [, AR <i>n</i>]	Indirect with left shift of 16
	ADD # <i>k</i>	Short immediate addressing
	ADD # <i>lk</i> [, <i>shift</i>]	Long immediate addressing

Operands	<i>dma</i> :	7 LSBs of the data-memory address
	<i>shift</i> :	Left shift value from 0 to 15 (defaults to 0)
	<i>n</i> :	Value from 0 to 7 designating the next auxiliary register
	<i>k</i> :	8-bit short immediate value
	<i>lk</i> :	16-bit long immediate value
	<i>ind</i> :	Select one of the following seven options: * *+ *− *0+ *0− *BR0+ *BR0−

Opcode**ADD** *dma* [, *shift*]

15	14	13	12	11	10	9	8	7	6	5	4	3	2	1	0
0	0	1	0	shift				0	dma						

ADD *dma*, **16**

15	14	13	12	11	10	9	8	7	6	5	4	3	2	1	0
0	1	1	0	0	0	0	1	0	dma						

ADD *ind* [, *shift* [, **AR***n*]]

15	14	13	12	11	10	9	8	7	6	5	4	3	2	1	0
0	0	1	0	shift				1	ARU	N	NAR				

Note: ARU, N, and NAR are defined in Section 6.3, *Indirect Addressing Mode* (page 6-9).

ADD *ind*, **16** [, **AR***n*]

15	14	13	12	11	10	9	8	7	6	5	4	3	2	1	0
0	1	1	0	0	0	0	1	1	ARU	N	NAR				

Note: ARU, N, and NAR are defined in Section 6.3, *Indirect Addressing Mode* (page 6-9).

ADD **#***k*

15	14	13	12	11	10	9	8	7	6	5	4	3	2	1	0
1	0	1	1	1	0	0	0	k							

ADD **#***lk* [, *shift*]

15	14	13	12	11	10	9	8	7	6	5	4	3	2	1	0
1	0	1	1	1	1	1	1	1	0	0	1	shift			
lk															

Execution	Increment PC, then ...		
	<u>Event</u>		<u>Addressing mode</u>
	$(ACC) + ((\text{data-memory address}) \times 2^{\text{shift}}) \rightarrow ACC$		Direct or indirect
	$(ACC) + ((\text{data-memory address}) \times 2^{16}) \rightarrow ACC$		Direct or indirect (shift of 16)
	$(ACC) + k \rightarrow ACC$		Short immediate
	$(ACC) + lk \times 2^{\text{shift}} \rightarrow ACC$		Long immediate
Status Bits	<u>Affected by</u>	<u>Affects</u>	<u>Addressing mode</u>
	SXM and OVM	C and OV	Direct or indirect
	OVM	C and OV	Short immediate
	SXM and OVM	C and OV	Long immediate
Description	<p>The content of the addressed data memory location or an immediate constant is left-shifted and added to the accumulator. During shifting, low-order bits are zero filled. High-order bits are sign extended if SXM = 1 and zero filled if SXM = 0. The result is stored in the accumulator. When short immediate addressing is used, the addition is unaffected by SXM and is not repeatable.</p> <p>If you are using indirect addressing and update the ARP, you must specify a shift operand. However, if you do not want a shift to occur, enter a 0 for this operand. For example:</p> <pre>ADD *, 0, AR2</pre> <p>Normally, the carry bit is set (C = 1) if the result of the addition generates a carry and is cleared (C = 0) if it does not generate a carry. However, when adding with a shift of 16, the carry bit is set if a carry is generated but otherwise, the carry bit is unaffected. This allows the accumulator to generate the proper single carry when adding a 32-bit number to the accumulator.</p>		
	Words	<u>Words</u>	<u>Addressing mode</u>
	1		Direct, indirect, or short immediate
	2		Long immediate

Cycles

Cycles for a Single ADD Instruction (Using Direct and Indirect Addressing)

Operand	Program			
	ROM	DARAM	SARAM	External
DARAM	1	1	1	1+p
SARAM	1	1	1, 2†	1+p
External	1+d	1+d	1+d	2+d+p

† If the operand and the code are in the same SARAM block

Cycles for a Repeat (RPT) Execution of an ADD Instruction (Using Direct and Indirect Addressing)

Operand	Program			
	ROM	DARAM	SARAM	External
DARAM	n	n	n	n+p
SARAM	n	n	n, n+1†	n+p
External	n+nd	n+nd	n+nd	n+1+p+nd

† If the operand and the code are in the same SARAM block

Cycles for a Single ADD Instruction (Using Short Immediate Addressing)

ROM	DARAM	SARAM	External
1	1	1	1+p

Cycles for a Single ADD Instruction (Using Long Immediate Addressing)

ROM	DARAM	SARAM	External
2	2	2	2+2p

Example 1

ADD 1, 1 ; (DP = 6)

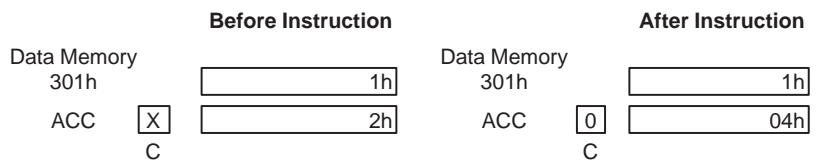

Example 2

ADD *, 0, AR0

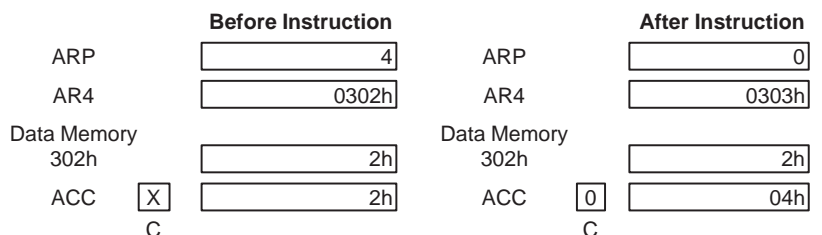

Example 3

ADD #1h ;Add short immediate

	Before Instruction		After Instruction	
ACC	X	2h	0	03h
	C		C	

Example 4

ADD #1111h,1 ;Add long immediate with shift of 1

	Before Instruction		After Instruction	
ACC	X	2h	0	2224h
	C		C	

Cycles for a Repeat (RPT) Execution of an ADDC Instruction

Operand	Program			
	ROM	DARAM	SARAM	External
DARAM	n	n	n	n+p
SARAM	n	n	n, n+1†	n+p
External	n+nd	n+nd	n+nd	n+1+p+nd

† If the operand and the code are in the same SARAM block

Example 1

```
ADDC    DAT300    ;(DP = 6: addresses 0300h-037Fh;
                ;DAT300 is a label for 300h)
```

		Before Instruction				After Instruction	
Data Memory	300h	<input type="text" value="04h"/>		Data Memory	300h	<input type="text" value="04h"/>	
ACC	<input type="text" value="1"/> C	<input type="text" value="13h"/>		ACC	<input type="text" value="0"/> C	<input type="text" value="18h"/>	

Example 2

```
ADDC    *- ,AR4    ;(OVM = 0)
```

		Before Instruction				After Instruction	
ARP		<input type="text" value="0"/>		ARP		<input type="text" value="4"/>	
AR0		<input type="text" value="300h"/>		AR0		<input type="text" value="299h"/>	
Data Memory	300h	<input type="text" value="0h"/>		Data Memory	300h	<input type="text" value="0h"/>	
ACC	<input type="text" value="1"/> C	<input type="text" value="0FFFFFFFh"/>		ACC	<input type="text" value="1"/> C	<input type="text" value="0h"/>	
		<input type="text" value="X"/> OV				<input type="text" value="0"/> OV	

Cycles for a Repeat (RPT) Execution of an ADDS Instruction

Operand	Program			
	ROM	DARAM	SARAM	External
DARAM	n	n	n	n+p
SARAM	n	n	n, n+1†	n+p
External	n+nd	n+nd	n+nd	n+1+p+nd

† If the operand and the code are in the same SARAM block

Example 1

ADDS 0 ; (DP = 6: addresses 0300h-037Fh)

		Before Instruction		After Instruction	
Data Memory	300h	0F006h	Data Memory	300h	0F006h
ACC	<input checked="" type="checkbox"/> C	0000003h	ACC	<input type="checkbox"/> C	0000F009h

Example 2

ADDS *

		Before Instruction		After Instruction	
ARP		0	ARP		0
AR0		0300h	AR0		0300h
Data Memory	300h	0FFFFh	Data Memory	300h	0FFFFh
ACC	<input checked="" type="checkbox"/> C	7FFF0000h	ACC	<input type="checkbox"/> C	7FFFFFFFh

Cycles for a Repeat (RPT) Execution of an ADDT Instruction

Operand	Program			
	ROM	DARAM	SARAM	External
DARAM	n	n	n	n+p
SARAM	n	n	n, n+1†	n+p
External	n+nd	n+nd	n+nd	n+1+p+nd

† If the operand and the code are in the same SARAM block

Example 1

ADDT 127 ; (DP = 4: addresses 0200h-027Fh,
; SXM = 0)

		Before Instruction			After Instruction
Data Memory	027Fh	09h	Data Memory	027Fh	09h
TREG		0FF94h	TREG		0FF94h
ACC	X	0F715h	ACC	0	0F7A5h
	C			C	

Example 2

ADDT *- ,AR4 ; (SXM = 0)

		Before Instruction			After Instruction
ARP		0	ARP		4
AR0		027Fh	AR0		027Eh
Data Memory	027Fh	09h	Data Memory	027Fh	09h
TREG		0FF94h	TREG		0FF94h
ACC	X	0F715h	ACC	0	0F7A5h
	C			C	

Syntax **ADRK #k** Short immediate addressing

Operands k: 8-bit short immediate value

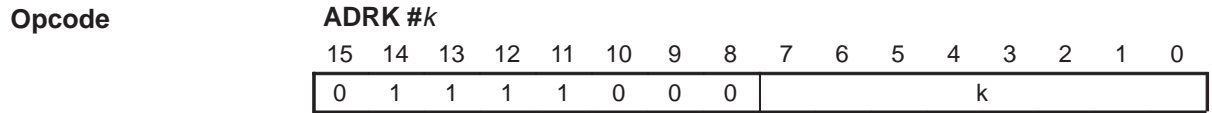

Execution Increment PC, then ...
 (current AR) + 8-bit positive constant → current AR

Status Bits None

Description The 8-bit immediate value is added, right justified, to the current auxiliary register (the one specified by the current ARP value) and the result replaces the auxiliary register contents. The addition takes place in the ARAU, with the immediate value treated as an 8-bit positive integer. All arithmetic operations on the auxiliary registers are unsigned.

Words 1

Cycles

Cycles for a Single ADRK Instruction			
ROM	DARAM	SARAM	External
1	1	1	1+p

Example ADRK #80h

		Before Instruction		After Instruction
	ARP	5	ARP	5
	AR5	4321h	AR5	43A1h

Syntax	AND <i>dma</i> AND <i>ind</i> [, AR <i>n</i>] AND #lk [, <i>shift</i>] AND #lk , 16	Direct addressing Indirect addressing Long immediate addressing Long immediate with left shift of 16
---------------	--	---

Operands	<i>dma</i> : 7 LSBs of the data-memory address <i>shift</i> : Left shift value from 0 to 15 (defaults to 0) <i>n</i> : Value from 0 to 7 designating the next auxiliary register <i>lk</i> : 16-bit long immediate value <i>ind</i> : Select one of the following seven options: * *+ *− *0+ *0− *BR0+ *BR0−
-----------------	---

Opcode	<p>AND <i>dma</i></p> <table border="1" style="width: 100%; border-collapse: collapse; text-align: center;"> <tr> <td>15</td><td>14</td><td>13</td><td>12</td><td>11</td><td>10</td><td>9</td><td>8</td><td>7</td><td>6</td><td>5</td><td>4</td><td>3</td><td>2</td><td>1</td><td>0</td> </tr> <tr> <td>0</td><td>1</td><td>1</td><td>0</td><td>1</td><td>1</td><td>1</td><td>0</td><td>0</td><td colspan="7">dma</td> </tr> </table> <p>AND <i>ind</i> [, AR<i>n</i>]</p> <table border="1" style="width: 100%; border-collapse: collapse; text-align: center;"> <tr> <td>15</td><td>14</td><td>13</td><td>12</td><td>11</td><td>10</td><td>9</td><td>8</td><td>7</td><td>6</td><td>5</td><td>4</td><td>3</td><td>2</td><td>1</td><td>0</td> </tr> <tr> <td>0</td><td>1</td><td>1</td><td>0</td><td>1</td><td>1</td><td>1</td><td>0</td><td>1</td><td>ARU</td><td>N</td><td colspan="5">NAR</td> </tr> </table> <p>Note: ARU, N, and NAR are defined in Section 6.3, <i>Indirect Addressing Mode</i> (page 6-9).</p> <p>AND #lk [, <i>shift</i>]</p> <table border="1" style="width: 100%; border-collapse: collapse; text-align: center;"> <tr> <td>15</td><td>14</td><td>13</td><td>12</td><td>11</td><td>10</td><td>9</td><td>8</td><td>7</td><td>6</td><td>5</td><td>4</td><td>3</td><td>2</td><td>1</td><td>0</td> </tr> <tr> <td>1</td><td>0</td><td>1</td><td>1</td><td>1</td><td>1</td><td>1</td><td>1</td><td>1</td><td>0</td><td>1</td><td>1</td><td colspan="4">shift</td> </tr> <tr> <td colspan="16">lk</td> </tr> </table> <p>AND #lk, 16</p> <table border="1" style="width: 100%; border-collapse: collapse; text-align: center;"> <tr> <td>15</td><td>14</td><td>13</td><td>12</td><td>11</td><td>10</td><td>9</td><td>8</td><td>7</td><td>6</td><td>5</td><td>4</td><td>3</td><td>2</td><td>1</td><td>0</td> </tr> <tr> <td>1</td><td>0</td><td>1</td><td>1</td><td>1</td><td>1</td><td>1</td><td>0</td><td>1</td><td>0</td><td>0</td><td>0</td><td>0</td><td>0</td><td>0</td><td>1</td> </tr> <tr> <td colspan="16">lk</td> </tr> </table>	15	14	13	12	11	10	9	8	7	6	5	4	3	2	1	0	0	1	1	0	1	1	1	0	0	dma							15	14	13	12	11	10	9	8	7	6	5	4	3	2	1	0	0	1	1	0	1	1	1	0	1	ARU	N	NAR					15	14	13	12	11	10	9	8	7	6	5	4	3	2	1	0	1	0	1	1	1	1	1	1	1	0	1	1	shift				lk																15	14	13	12	11	10	9	8	7	6	5	4	3	2	1	0	1	0	1	1	1	1	1	0	1	0	0	0	0	0	0	1	lk															
15	14	13	12	11	10	9	8	7	6	5	4	3	2	1	0																																																																																																																																																		
0	1	1	0	1	1	1	0	0	dma																																																																																																																																																								
15	14	13	12	11	10	9	8	7	6	5	4	3	2	1	0																																																																																																																																																		
0	1	1	0	1	1	1	0	1	ARU	N	NAR																																																																																																																																																						
15	14	13	12	11	10	9	8	7	6	5	4	3	2	1	0																																																																																																																																																		
1	0	1	1	1	1	1	1	1	0	1	1	shift																																																																																																																																																					
lk																																																																																																																																																																	
15	14	13	12	11	10	9	8	7	6	5	4	3	2	1	0																																																																																																																																																		
1	0	1	1	1	1	1	0	1	0	0	0	0	0	0	1																																																																																																																																																		
lk																																																																																																																																																																	

Execution	Increment PC, then ... <u>Event(s)</u> <u>Addressing mode</u> (ACC(15:0)) AND (data-memory address) → ACC(15:0) Direct or indirect 0 → ACC(31:16) (ACC(31:0)) AND lk × 2 ^{shift} → ACC Long immediate (ACC(31:0)) AND lk × 2 ¹⁶ → ACC Long immediate with left shift of 16
------------------	--

Status Bits None

This instruction is not affected by SXM.

Description If direct or indirect addressing is used, the low word of the accumulator is ANDed with a data-memory value, and the result is placed in the low word position in the accumulator. The high word of the accumulator is zeroed. If immediate addressing is used, the long-immediate constant can be shifted. During the shift, low-order and high-order bits not filled by the shifted value are zeroed. The resulting value is ANDed with the accumulator contents.

Words	<u>Words</u>	<u>Addressing mode</u>
	1	Direct or indirect
	2	Long immediate

Cycles

Cycles for a Single AND Instruction (Using Direct and Indirect Addressing)

Operand	Program			
	ROM	DARAM	SARAM	External
DARAM	1	1	1	1+p
SARAM	1	1	1, 2 [†]	1+p
External	1+d	1+d	1+d	2+d+p

[†] If the operand and the code are in the same SARAM block

Cycles for a Repeat (RPT) Execution of an AND Instruction (Using Direct and Indirect Addressing)

Operand	Program			
	ROM	DARAM	SARAM	External
DARAM	n	n	n	n+p
SARAM	n	n	n, n+1 [†]	n+p
External	n+nd	n+nd	n+nd	n+1+p+nd

[†] If the operand and the code are in the same SARAM block

Cycles for a Single AND Instruction (Using Long Immediate Addressing)

ROM	DARAM	SARAM	External
2	2	2	2+2p

Example 1 AND 16 ; (DP = 4: addresses 0200h-027Fh)

	Before Instruction		After Instruction
Data Memory 0210h	00FFh	Data Memory 0210h	00FFh
ACC	12345678h	ACC	00000078h

Example 2 AND *

	Before Instruction		After Instruction
ARP	0	ARP	0
AR0	0301h	AR0	0301h
Data Memory 0301h	0FF00h	Data Memory 0301h	0FF00h
ACC	12345678h	ACC	00005600h

Example 3 AND #00FFh, 4

	Before Instruction		After Instruction
ACC	12345678h	ACC	00000670h

Syntax APAC**Operands** None**Opcode** APAC

15	14	13	12	11	10	9	8	7	6	5	4	3	2	1	0
1	0	1	1	1	1	1	0	0	0	0	0	0	1	0	0

Execution Increment PC, then ...
(ACC) + shifted (PREG) → ACC**Status Bits** Affected by PM and OVM Affects C and OV

This instruction is not affected by SXM.

Description The contents of PREG are shifted as defined by the PM status bits of the ST1 register (see Table 7–7) and added to the contents of the accumulator. The result is placed in the accumulator. APAC is not affected by the SXM bit of the status register. PREG is always sign extended. The task of the APAC instruction is also performed as a subtask of the LTA, LTD, MAC, MACD, MPYA, and SQRA instructions.

Table 7–7. Product Shift Modes

PM Bits		Resulting Shift
Bit 1	Bit 0	
0	0	No shift
0	1	Left shift of 1 bit
1	0	Left shift of 4 bits
1	1	Right shift of 6 bits

Words 1**Cycles**

Cycles for a Single APAC Instruction			
ROM	DARAM	SARAM	External
1	1	1	1+p

Cycles for a Repeat (RPT) Execution of an APAC Instruction			
ROM	DARAM	SARAM	External
n	n	n	n+p

Example

APAC ; (PM = 01)

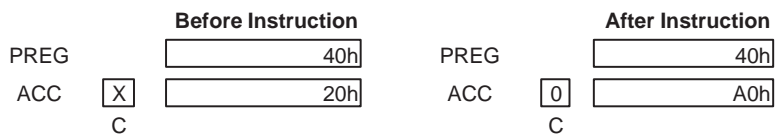

Syntax **B** *pma* [, *ind* [, **AR***n*]] Indirect addressing

Operands

pma: 16-bit program-memory address

n: Value from 0 to 7 designating the next auxiliary register

ind: Select one of the following seven options:
 * *+ *- *0+ *0- *BR0+ *BR0-

Opcode **B** *pma* [, *ind* [, **AR***n*]]

15	14	13	12	11	10	9	8	7	6	5	4	3	2	1	0
0	1	1	1	1	0	0	1	1	ARU		N		NAR		
pma															

Note: ARU, N, and NAR are defined in Section 6.3, *Indirect Addressing Mode* (page 6-9).

Execution *pma* → PC
 Modify (current AR) and (ARP) as specified.

Status Bits None

Description The current auxiliary register and ARP contents are modified as specified, and control is passed to the designated program-memory address (*pma*). The *pma* can be either a symbolic or numeric address.

Words 2

Cycles

Cycles for a Single B Instruction

ROM	DARAM	SARAM	External
4	4	4	4+4p

Note: When this instruction reaches the execute phase of the pipeline, two additional instruction words have entered the pipeline. When the PC discontinuity is taken, these two instruction words are discarded.

Example **B** 191, *+, AR1

The value 191 is loaded into the program counter, and the program continues to execute from that location. The current auxiliary register is incremented by 1, and ARP is set to point to auxiliary register 1 (AR1).

Syntax **BACC**

Operands None

Opcode

15	14	13	12	11	10	9	8	7	6	5	4	3	2	1	0
1	0	1	1	1	1	1	0	0	0	1	0	0	0	0	0

Execution ACC(15:0) → PC

Status Bits None

Description Control is passed to the 16-bit address residing in the lower half of the accumulator.

Words 1

Cycles

Cycles for a Single BACC Instruction			
ROM	DARAM	SARAM	External
4	4	4	4+3p

Note: When this instruction reaches the execute phase of the pipeline, two additional instruction words have entered the pipeline. When the PC discontinuity is taken, these two instruction words are discarded.

Example BACC ; (ACC contains the value 191)

The value 191 is loaded into the program counter, and the program continues to execute from that location.

Syntax **BANZ** *pma* [, *ind* [, **AR***n*]] Indirect addressing

Operands
pma: 16-bit program-memory address
n: Value from 0 to 7 designating the next auxiliary register
ind: Select one of the following seven options:
 * *+ *− *0+ *0− *BR0+ *BR0−

Opcode **BANZ** *pma* [, *ind* [, **AR***n*]]

15	14	13	12	11	10	9	8	7	6	5	4	3	2	1	0
0	1	1	1	1	0	1	1	1	ARU		N		NAR		
pma															

Note: ARU, N, and NAR are defined in Section 6.3, *Indirect Addressing Mode* (page 6-9).

Execution
 If (current AR) \neq 0
 Then *pma* \rightarrow PC
 Else (PC) + 2 \rightarrow PC
 Modify (current AR) and (ARP) as specified

Status Bits None

Description
 Control is passed to the designated program-memory address (*pma*) if the contents of the current auxiliary register are not zero. Otherwise, control passes to the next instruction. The default modification to the current AR is a decrement by one. N loop iterations can be executed by initializing an auxiliary register (as a loop counter) to N−1 prior to loop entry. The *pma* can be either a symbolic or a numeric address.

Words 2

Cycles

Cycles for a Single BANZ Instruction

Condition	ROM	DARAM	SARAM	External
True	4	4	4	4+4p
False	2	2	2	2+2p

Note: The 'C2xx performs speculative fetching by reading two additional instruction words. If the PC discontinuity is taken, these two instruction words are discarded.

Example 1

	BANZ	PGM0		<i>;(PGM0 labels program address 0)</i>	
			Before Instruction		After Instruction
	ARP		0	ARP	0
	AR0		5h	AR0	4h

Because the content of AR0 is not zero, the program branches to program address 0 is loaded into the program counter (PC), and the program continues executing from that location. The default auxiliary register operation is a decrement of the current auxiliary register content; thus, AR0 contains 4h at the end of the execution.

or

			Before Instruction		After Instruction
	ARP		0	ARP	0
	AR0		0h	AR0	FFFFh

Because the content of AR0 is zero, the branch is not executed; instead, the PC is incremented by 2, and execution continues with the instruction following the BANZ instruction. Because of the default decrement, AR0 is decremented by 1, becoming -1.

Example 2

```

MAR *,AR0           ;Set ARP to point to AR0.
LAR AR1,#3          ;Load AR1 with 3.
LAR AR0,#60h        ;Load AR0 with 60h.
PGM191 ADD *+,AR1    ;Loop: While AR1 not zero,
BANZ PGM191,AR0    ;add data referenced by AR0
                   ;to accumulator and increment
                   ;AR0 value.
    
```

The contents of data-memory locations 60h–63h are added to the accumulator.

Syntax **BCND** *pma*, *cond 1* [, *cond 2*] [,...]

Operands *pma*: 16-bit program-memory address

<u><i>cond</i></u>	<u>Condition</u>
EQ	ACC = 0
NEQ	ACC ≠ 0
LT	ACC < 0
LEQ	ACC ≤ 0
GT	ACC > 0
GEQ	ACC ≥ 0
NC	C = 0
C	C = 1
NOV	OV = 0
OV	OV = 1
BIO	$\overline{\text{BIO}}$ low
NTC	TC = 0
TC	TC = 1
UNC	Unconditionally

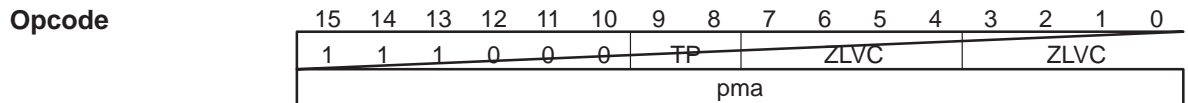

Note: The TP and ZLVC fields are defined on pages 7-3 and 7-4.

Execution If *cond 1* AND *cond 2* AND ...
 Then *pma* → PC
 Else increment PC

Status Bits None

Description A branch is taken to the specified program-memory address (*pma*) if the specified conditions are met. Not all combinations of conditions are meaningful. For example, testing for LT and GT is contradictory. In addition, testing $\overline{\text{BIO}}$ is mutually exclusive to testing TC.

Words 2

Cycles for a Single BCND Instruction

Condition	ROM	DARAM	SARAM	External
True	4	4	4	4+4p
False	2	2	2	2+2p

Note: The 'C2xx performs speculative fetching by reading two additional instruction words. If the PC discontinuity is taken, these two instruction words are discarded.

Example

BCND PGM191 , LEQ , C

If the accumulator contents are less than or equal to zero and the carry bit is set, program address 191 is loaded into the program counter, and the program continues to execute from that location. If these conditions do not hold, execution continues from location PC + 2.

Syntax **BIT** *dma*, *bit code* Direct addressing
BIT *ind*, *bit code* [, **AR***n*] Indirect addressing

Operands *dma*: 7 LSBs of the data-memory address
bit code: Value from 0 to 15 indicating which bit to test (see Figure 7–1)
n: Value from 0 to 7 designating the next auxiliary register
ind: Select one of the following seven options:
 * *+ *- *0+ *0- *BR0+ *BR0-

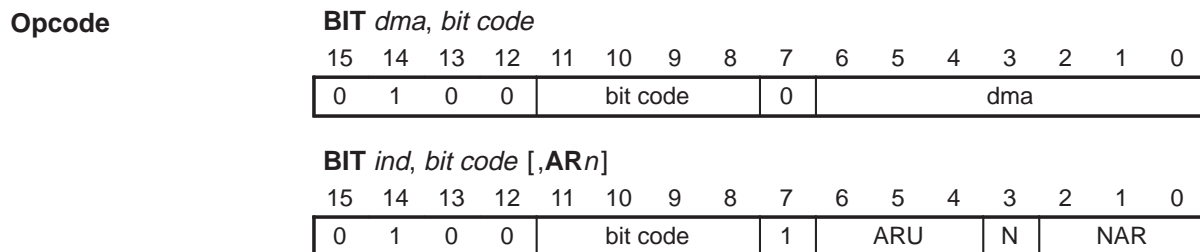

Note: ARU, N, and NAR are defined in Section 6.3, *Indirect Addressing Mode* (page 6-9).

Execution Increment PC, then ...
 (data bit number (15 – bit code)) → TC

Status Bits Affects
 TC

Description The BIT instruction copies the specified bit of the data-memory value to the TC bit of status register ST1. Note that the BITT, CMPR, LST #1, and NORM instructions also affect the TC bit in ST1. A bit code value is specified that corresponds to a certain bit number of the data-memory value, as shown in Figure 7–1.

Figure 7–1. Bit Numbers and Their Corresponding Bit Codes for BIT Instruction



Words 1

Cycles

Cycles for a Single BIT Instruction

Operand	Program			
	ROM	DARAM	SARAM	External
DARAM	1	1	1	1+p
SARAM	1	1	1, 2†	1+p
External	1+d	1+d	1+d	2+d+p

† If the operand and the code are in the same SARAM block

Cycles for a Repeat (RPT) Execution of a BIT Instruction

Operand	Program			
	ROM	DARAM	SARAM	External
DARAM	n	n	n	n+p
SARAM	n	n	n, n+1†	n+p
External	n+nd	n+nd	n+nd	n+1+p+nd

† If the operand and the code are in the same SARAM block

Example 1

BIT 0h,15 ;(DP = 6). Test LSB at 300h

	Before Instruction		After Instruction	
Data Memory 300h	<input type="text" value="4DC8h"/>	Data Memory 300h	<input type="text" value="4DC8h"/>	
TC	<input type="text" value="0"/>	TC	<input type="text" value="0"/>	

Example 2

BIT *,0,AR1 ;Test MSB at 310h, then set ARP = 1

	Before Instruction		After Instruction	
ARP	<input type="text" value="0"/>	ARP	<input type="text" value="1"/>	
AR0	<input type="text" value="310h"/>	AR0	<input type="text" value="310h"/>	
Data Memory 310h	<input type="text" value="8000h"/>	Data Memory 310h	<input type="text" value="8000h"/>	
TC	<input type="text" value="0"/>	TC	<input type="text" value="1"/>	

Cycles

Cycles for a Single BITT Instruction

Operand	Program			
	ROM	DARAM	SARAM	External
DARAM	1	1	1	1+p
SARAM	1	1	1, 2†	1+p
External	1+d	1+d	1+d	2+d+p

† If the operand and the code are in the same SARAM block

Cycles for a Repeat (RPT) Execution of an BITT Instruction

Operand	Program			
	ROM	DARAM	SARAM	External
DARAM	n	n	n	n+p
SARAM	n	n	n, n+1†	n+p
External	n+nd	n+nd	n+nd	n+1+p+nd

† If the operand and the code are in the same SARAM block

Example 1

BITT 00h ;(DP = 6) Test bit 14 of data
 ;at 300h

	Before Instruction		After Instruction
Data Memory 300h	4DC8h	Data Memory 300h	4DC8h
TREG	1h	TREG	1h
TC	0	TC	1

Example 2

BITT * ;Test bit 1 of data at 310h

	Before Instruction		After Instruction
ARP	1	ARP	1
AR1	310h	AR1	310h
Data Memory 310h	8000h	Data Memory 310h	8000h
TREG	0Eh	TREG	0Eh
TC	0	TC	0

SyntaxGeneral syntax: **BLDD** *source, destination*

BLDD <i>#lk, dma</i>	Direct with long immediate source
BLDD <i>#lk, ind [, ARn]</i>	Indirect with long immediate source
BLDD <i>dma, #lk</i>	Direct with long immediate destination
BLDD <i>ind, #lk [, ARn]</i>	Indirect with long immediate destination

Operands

dma: 7 LSBs of the data-memory address
n: Value from 0 to 7 designating the next auxiliary register
lk: 16-bit long immediate value
ind: Select one of the following seven options:
* *+ *− *0+ *0− *BR0+ *BR0−

Opcode**BLDD** *#lk, dma*

15	14	13	12	11	10	9	8	7	6	5	4	3	2	1	0
1	0	1	0	1	0	0	0	0	dma						
lk															

BLDD *#lk, ind [, ARn]*

15	14	13	12	11	10	9	8	7	6	5	4	3	2	1	0
1	0	1	0	1	0	0	0	1	ARU	N	NAR				
lk															

Note: ARU, N, and NAR are defined in Section 6.3, *Indirect Addressing Mode* (page 6-9).**BLDD** *dma, #lk*

15	14	13	12	11	10	9	8	7	6	5	4	3	2	1	0
1	0	1	0	1	0	0	1	0	dma						
lk															

BLDD *ind, #lk [, ARn]*

15	14	13	12	11	10	9	8	7	6	5	4	3	2	1	0
1	0	1	0	1	0	0	1	1	ARU	N	NAR				
lk															

Note: ARU, N, and NAR are defined in Section 6.3, *Indirect Addressing Mode* (page 6-9).

Execution Increment PC, then ...
 (PC) → MSTACK
 lk → PC
 (source) → destination
 For indirect, modify (current AR) and (ARP) as specified
 (PC) + 1 → PC

 While (repeat counter) ≠ 0:
 (source) → destination
 For indirect, modify (current AR) and (ARP) as specified
 (PC) + 1 → PC
 (repeat counter) -1 → repeat counter

 (MSTACK) → PC

Status Bits None

Description The word in data memory pointed to by *source* is copied to a data-memory space pointed at by *destination*. The word of the source and/or destination space can be pointed at with a long-immediate value or by a data-memory address. Note that not all source/destination combinations of pointer types are valid.

Note:
BLDD will not work with memory-mapped registers.

RPT can be used with the BLDD instruction to move consecutive words in data memory. The number of words to be moved is one greater than the number contained in the repeat counter (RPTC) at the beginning of the instruction. When the BLDD instruction is repeated, the source (destination) address specified by the long immediate constant is stored to the PC. Because the PC is incremented by 1 during each repetition, it is possible to access a series of source (destination) addresses. If you use indirect addressing to specify the destination (source) address, a new destination (source) address can be accessed during each repetition. If you use the direct addressing mode, the specified destination (source) address is a constant; it will not be modified during each repetition.

The source and destination blocks do not have to be entirely on chip or off chip. Interrupts are inhibited during a BLDD operation used with the RPT instruction. When used with RPT, BLDD becomes a single-cycle instruction once the RPT pipeline is started.

Words 2

Cycles**Cycles for a Single BLDD Instruction**

Operand	ROM	DARAM	SARAM	External
Source: DARAM Destination: DARAM	3	3	3	3+2p
Source: SARAM Destination: DARAM	3	3	3	3+2p
Source: External Destination: DARAM	3+d _{src}	3+d _{src}	3+d _{src}	3+d _{src} +2p
Source: DARAM Destination: SARAM	3	3	3 4†	3+2p
Source: SARAM Destination: SARAM	3	3	3 4†	3+2p
Source: External Destination: SARAM	3+d _{src}	3+d _{src}	3+d _{src} 4+d _{src} †	3+d _{src} +2p
Source: DARAM Destination: External	4+d _{dst}	4+d _{dst}	4+d _{dst}	6+d _{dst} +2p
Source: SARAM Destination: External	4+d _{dst}	4+d _{dst}	4+d _{dst}	6+d _{dst} +2p
Source: External Destination: External	4+d _{src} +d _{dst}	4+d _{src} +d _{dst}	4+d _{src} +d _{dst}	6+d _{src} +d _{dst} +2p

† If the destination operand and the code are in the same SARAM block.

Cycles for a Repeat (RPT) Execution of a BLDD Instruction

Operand	ROM	DARAM	SARAM	External
Source: DARAM Destination: DARAM	n+2	n+2	n+2	n+2+2p
Source: SARAM Destination: DARAM	n+2	n+2	n+2	n+2+2p
Source: External Destination: DARAM	n+2+nd _{src}	n+2+nd _{src}	n+2+nd _{src}	n+2+nd _{src} +2p
Source: DARAM Destination: SARAM	n+2	n+2	n+2 n+4†	n+2+2p
Source: SARAM Destination: SARAM	n+2 2n‡	n+2 2n‡	n+2 2n‡ n+4† 2n+2§	n+2+2p 2n+2p‡
Source: External Destination: SARAM	n+2+nd _{src}	n+2+nd _{src}	n+2+nd _{src} n+4+nd _{src} †	n+2+nd _{src} +2p
Source: DARAM Destination: External	2n+2+nd _{dst}	2n+2+nd _{dst}	2n+2+nd _{dst}	2n+2+nd _{dst} +2p
Source: SARAM Destination: External	2n+2+nd _{dst}	2n+2+nd _{dst}	2n+2+nd _{dst}	2n+2+nd _{dst} +2p
Source: External Destination: External	4n+nd _{src} +nd _{dst} ‡	4n+nd _{src} +nd _{dst}	4n+nd _{src} +nd _{dst}	4n+2+nd _{src} +nd _{dst} +2p

† If the destination operand and the code are in the same SARAM block

‡ If both the source and the destination operands are in the same SARAM block

§ If both operands and the code are in the same SARAM block

Example 1

BLDD #300h,20h ;(DP = 6)

		Before Instruction			After Instruction
Data Memory			Data Memory		
	300h	0h		300h	0h
	320h	0Fh		320h	0h

Example 2

BLDD *+,#321h,AR3

		Before Instruction			After Instruction
ARP		2	ARP		3
AR2		301h	AR2		302h
Data Memory			Data Memory		
	301h	01h		301h	01h
	321h	0Fh		321h	01h

Syntax General syntax: **BLPD** *source, destination*

BLPD #pma, dma Direct with long immediate source

BLPD #pma, ind [, ARn] Indirect with long immediate source

Operands

pma: 16-bit program-memory address
 dma: 7 LSBs of the data-memory address
 n: Value from 0 to 7 designating the next auxiliary register
 ind: Select one of the following seven options:
 * *+ *− *0+ *0− *BR0+ *BR0−

Opcode

BLPD #pma, dma

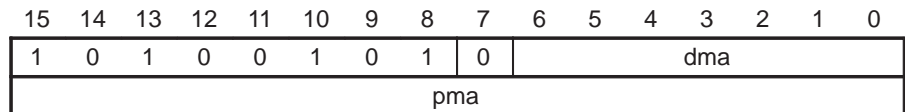

BLPD #pma, ind [, ARn]

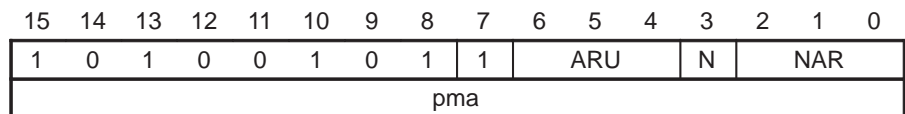

Note: ARU, N, and NAR are defined in Section 6.3, *Indirect Addressing Mode* (page 6-9).

Execution

Increment PC, then ...
 (PC) → MSTACK
 pma → PC
 (source) → destination
 For indirect, modify (current AR) and (ARP) as specified
 (PC) + 1 → PC

While (repeat counter) ≠ 0:
 (source) → destination
 For indirect, modify (current AR) and (ARP) as specified
 (PC) + 1 → PC
 (repeat counter) − 1 → repeat counter

(MSTACK) → PC

Status Bits

None

Description

A word in program memory pointed to by the *source* is copied to data-memory space pointed to by *destination*. The first word of the source space is pointed to by a long-immediate value. The data-memory destination space is pointed to by a data-memory address or auxiliary register pointer. Not all source/destination combinations of pointer types are valid.

RPT can be used with the BLPD instruction to move consecutive words. The number of words to be moved is one greater than the number contained in the repeat counter (RPTC) at the beginning of the instruction. When the BLPD instruction is repeated, the source (program-memory) address specified by the long immediate constant is stored to the PC. Because the PC is incremented by 1 during each repetition, it is possible to access a series of program-memory addresses. If you use indirect addressing to specify the destination (data-memory) address, a new data-memory address can be accessed during each repetition. If you use the direct addressing mode, the specified data-memory address is a constant; it will not be modified during each repetition.

The source and destination blocks do not have to be entirely on chip or off chip. Interrupts are inhibited during a repeated BLPD instruction. When used with RPT, BLPD becomes a single-cycle instruction once the RPT pipeline is started.

Words

2

Cycles

Cycles for a Single BLPD Instruction

Operand	ROM	DARAM	SARAM	External
Source: DARAM/ROM Destination: DARAM	3	3	3	$3+2p_{code}$
Source: SARAM Destination: DARAM	3	3	3	$3+2p_{code}$
Source: External Destination: DARAM	$3+p_{src}$	$3+p_{src}$	$3+p_{src}$	$3+p_{src}+2p_{code}$
Source: DARAM/ROM Destination: SARAM	3	3	3 4 [†]	$3+2p_{code}$
Source: SARAM Destination: SARAM	3	3	3 4 [†]	$3+2p_{code}$
Source: External Destination: SARAM	$3+p_{src}$	$3+p_{src}$	$3+p_{src}$ $4+p_{src}$ [†]	$3+p_{src}+2p_{code}$
Source: DARAM/ROM Destination: External	$4+d_{dst}$	$4+d_{dst}$	$4+d_{dst}$	$6+d_{dst}+2p_{code}$
Source: SARAM Destination: External	$4+d_{dst}$	$4+d_{dst}$	$4+d_{dst}$	$6+d_{dst}+2p_{code}$
Source: External Destination: External	$4+p_{src}+d_{dst}$	$4+p_{src}+d_{dst}$	$4+p_{src}+d_{dst}$	$6+p_{src}+d_{dst}+2p_{code}$

[†] If the destination operand and the code are in the same SARAM block

Cycles for a Repeat (RPT) Execution of a BLPD Instruction

Operand	ROM	DARAM	SARAM	External
Source: DARAM/ROM Destination: DARAM	n+2	n+2	n+2	$n+2+2p_{code}$
Source: SARAM Destination: DARAM	n+2	n+2	n+2	$n+2+2p_{code}$
Source: External Destination: DARAM	$n+2+np_{src}$	$n+2+np_{src}$	$n+2+np_{src}$	$n+2+np_{src}+2p_{code}$
Source: DARAM/ROM Destination: SARAM	n+2	n+2	n+2 n+4 [†]	$n+2+2p_{code}$

[†] If the destination operand and the code are in the same SARAM block

[‡] If both the source and the destination operands are in the same SARAM block

[§] If both operands and the code are in the same SARAM block

Cycles for a Repeat (RPT) Execution of a BLPD Instruction (Continued)

Operand	ROM	DARAM	SARAM	External
Source: SARAM Destination: SARAM	n+2 2n [†]	n+2 2n [†]	n+2 2n [†] n+4 [†] 2n+2 [§]	n+2+2p _{code} 2n+2p _{code} [†]
Source: External Destination: SARAM	n+2+np _{src} [†]	n+2+np _{src}	n+2+np _{src} n+4+np _{src} [†]	n+2+np _{src} +2p _{code}
Source: DARAM/ROM Destination: External	2n+2+nd _{dst}	2n+2+nd _{dst}	2n+2+nd _{dst}	2n+2+nd _{dst} +2p _{code}
Source: SARAM Destination: External	2n+2+nd _{dst}	2n+2+nd _{dst}	2n+2+nd _{dst}	2n+2+nd _{dst} +2p _{code}
Source: External Destination: External	4n+np _{src} +nd _{dst} [†]	4n+np _{src} +nd _{dst}	4n+np _{src} +nd _{dst}	4n+2+np _{src} +nd _{dst} + 2p _{code}

† If the destination operand and the code are in the same SARAM block
 ‡ If both the source and the destination operands are in the same SARAM block
 § If both operands and the code are in the same SARAM block

Example 1

BLPD #800h, 00h ; (DP=6)

		Before Instruction			After Instruction
Program Memory	800h	0Fh	Program Memory	800h	0Fh
Data Memory	300h	0h	Data Memory	300h	0Fh

Example 2

BLPD #800h, *, AR7

		Before Instruction			After Instruction
ARP		0	ARP		7
AR0		310h	AR0		310h
Program Memory	800h	1111h	Program Memory	800h	1111h
Data Memory	310h	0100h	Data Memory	310h	1111h

Syntax **CALA**

Operands None

Opcode

15	14	13	12	11	10	9	8	7	6	5	4	3	2	1	0
1	0	1	1	1	1	1	0	0	0	1	1	0	0	0	0

Execution PC + 1 → TOS
 ACC(15:0) → PC

Status Bits None

Description The current program counter (PC) is incremented and pushed onto the top of the stack (TOS). Then, the contents of the lower half of the accumulator are loaded into the PC. Execution continues at this address.

The CALA instruction is used to perform computed subroutine calls.

Words 1

Cycles

Cycles for a Single CALA Instruction			
ROM	DARAM	SARAM	External
4	4	4	4+3p

Note: When this instruction reaches the execute phase of the pipeline, two additional instruction words have entered the pipeline. When the PC discontinuity is taken, these two instruction words are discarded.

Example CALA

	Before Instruction		After Instruction
PC	25h	PC	83h
ACC	83h	ACC	83h
TOS	100h	TOS	26h

Syntax `CALL pma [, ind [, ARn]]` Indirect addressing

Operands
 pma: 16-bit program-memory address
 n: Value from 0 to 7 designating the next auxiliary register
 ind: Select one of the following seven options:
 * *+ *- *0+ *0- *BR0+ *BR0-

Opcode `CALL pma [, ind [, ARn]]`

15	14	13	12	11	10	9	8	7	6	5	4	3	2	1	0
0	1	1	1	1	0	1	0	1		ARU		N		NAR	
pma															

Note: ARU, N, and NAR are defined in Section 6.3, *Indirect Addressing Mode* (page 6-9).

Execution
 PC + 2 → TOS
 pma → PC
 Modify (current AR) and (ARP) as specified.

Status Bits None

Description
 The current program counter (PC) is incremented and pushed onto the top of the stack (TOS). Then, the contents of the pma, either a symbolic or numeric address, are loaded into the PC. Execution continues at this address. The current auxiliary register and ARP contents are modified as specified.

Words 2

Cycles

Cycles for a Single CALL Instruction

ROM	DARAM	SARAM	External
4	4	4	4+4p [†]

Note: When this instruction reaches the execute phase of the pipeline, two additional instruction words have entered the pipeline. When the PC discontinuity is taken, these two instruction words are discarded.

Example `CALL 191, *+, AR0`

	Before Instruction		After Instruction	
ARP	<input type="text" value="1"/>	ARP	<input type="text" value="0"/>	
AR1	<input type="text" value="05h"/>	AR1	<input type="text" value="06h"/>	
PC	<input type="text" value="30h"/>	PC	<input type="text" value="0BFh"/>	
TOS	<input type="text" value="100h"/>	TOS	<input type="text" value="32h"/>	

Program address 0BFh (191) is loaded into the program counter, and the program continues executing from that location.

Syntax **CC** *pma, cond 1* [*,cond 2*] [...]

Operands	<i>pma</i> : 16-bit program-memory address
	<u><i>cond</i></u> <u><i>Condition</i></u>
	EQ ACC = 0
	NEQ ACC ≠ 0
	LT ACC < 0
	LEQ ACC ≤ 0
	GT ACC > 0
	GEQ ACC ≥ 0
	NC C = 0
	C C = 1
	NOV OV = 0
	OV OV = 1
	BIO $\overline{\text{BIO}}$ low
	NTC TC = 0
	TC TC = 1
	UNC Unconditionally

Opcode

15	14	13	12	11	10	9	8	7	6	5	4	3	2	1	0
1	1	1	0	1	0	TP		ZLVC			ZLVC				
pma															

Note: The TP and ZLVC fields are defined on pages 7-3 and 7-4.

Execution If *cond 1* AND *cond 2* AND ...
 Then
 PC + 2 → TOS
 pma → PC
 Else
 Increment PC

Status Bits None

Description Control is passed to the specified program-memory address (*pma*) if the specified conditions are met. Not all combinations of conditions are meaningful. For example, testing for LT and GT is contradictory. In addition, testing $\overline{\text{BIO}}$ is mutually exclusive to testing TC. The CC instruction operates like the CALL instruction if all conditions are true.

Words 2

Cycles

Condition	ROM	DARAM	SARAM	External
True	4	4	4	4+4p†
False	2	2	2	2+2p

† The processor performs speculative fetching by reading two additional instruction words. If the PC discontinuity is taken these two instruction words are discarded.

Example

CC PGM191 , LEQ , C

If the accumulator contents are less than or equal to zero and the carry bit is set, 0BFh (191) is loaded into the program counter, and the program continues to execute from that location. If the conditions are not met, execution continues at the instruction following the CC instruction.

Syntax **CLRC** *control bit*

Operands control bit: Select one of the following control bits:

- C Carry bit of status register ST1
- CNF RAM configuration control bit of status register ST1
- INTM Interrupt mode bit of status register ST0
- OVM Overflow mode bit of status register ST0
- SXM Sign-extension mode bit of status register ST1
- TC Test/control flag bit of status register ST1
- XF XF pin status bit of status register ST1

Opcode

CLRC C

15	14	13	12	11	10	9	8	7	6	5	4	3	2	1	0
1	0	1	1	1	1	1	0	0	1	0	0	1	1	1	0

CLRC CNF

15	14	13	12	11	10	9	8	7	6	5	4	3	2	1	0
1	0	1	1	1	1	1	0	0	1	0	0	0	1	0	0

CLRC INTM

15	14	13	12	11	10	9	8	7	6	5	4	3	2	1	0
1	0	1	1	1	1	1	0	0	1	0	0	0	0	0	0

CLRC OVM

15	14	13	12	11	10	9	8	7	6	5	4	3	2	1	0
1	0	1	1	1	1	1	0	0	1	0	0	0	0	1	0

CLRC SXM

15	14	13	12	11	10	9	8	7	6	5	4	3	2	1	0
1	0	1	1	1	1	1	0	0	1	0	0	0	1	1	0

CLRC TC

15	14	13	12	11	10	9	8	7	6	5	4	3	2	1	0
1	0	1	1	1	1	1	0	0	1	0	0	1	0	1	0

CLRC XF

15	14	13	12	11	10	9	8	7	6	5	4	3	2	1	0
1	0	1	1	1	1	1	0	0	1	0	0	1	1	0	0

Execution Increment PC, then ...
0 → control bit

Status Bits None

Description The specified control bit is cleared to 0. Note that the LST instruction can also be used to load ST0 and ST1. See subsection 3.5, *Status Registers ST0 and ST1* on page 3-15, for more information on each of these control bits.

Words 1

Cycles

Cycles for a Single CLRC Instruction

ROM	DARAM	SARAM	External
1	1	1	1+p

Cycles for a Repeat (RPT) Execution of a CLRC Instruction

ROM	DARAM	SARAM	External
n	n	n	n+p

Example

CLRC TC ; (TC is bit 11 of ST1)

	Before Instruction		After Instruction
ST1	x9xxh	ST1	x1xxh

Syntax **CMPL**

Operands None

Opcode

15	14	13	12	11	10	9	8	7	6	5	4	3	2	1	0
1	0	1	1	1	1	1	0	0	0	0	0	0	0	0	1

Execution Increment PC, then ...
 $\overline{(ACC)} \rightarrow ACC$

Status Bits None

Description The contents of the accumulator are replaced with its logical inversion (1s complement). The carry bit is unaffected.

Words 1

Cycles

Cycles for a Single CMPL Instruction			
ROM	DARAM	SARAM	External
1	1	1	1+p

Cycles for a Repeat (RPT) Execution of an CMPL Instruction			
ROM	DARAM	SARAM	External
n	n	n	n+p

Example

CMPL

		Before Instruction		After Instruction
ACC	X	0F7982513h	ACC	X
	C			C
				0867DAECh

Syntax **CMPR** *CM*

Operands CM: Value from 0 to 3

Opcode

15	14	13	12	11	10	9	8	7	6	5	4	3	2	1	0
1	0	1	1	1	1	1	1	0	1	0	0	0	1	CM	

Execution Increment PC, then ...
Compare (current AR) to (AR0) and place the result in the TC bit of status register ST1.

Status Bits Affects
TC

This instruction is not affected by SXM. It does not affect SXM.

Description The CMPR instruction performs a comparison specified by the value of CM:

- If CM = 00, test whether (current AR) = (AR0)
- If CM = 01, test whether (current AR) < (AR0)
- If CM = 10, test whether (current AR) > (AR0)
- If CM = 11, test whether (current AR) ≠ (AR0)

If the condition is true, the TC bit is set to 1. If the condition is false, the TC bit is cleared to 0.

Note that the auxiliary register values are treated as unsigned integers in the comparisons.

Words 1

Cycles

Cycles for a Single CMPR Instruction			
ROM	DARAM	SARAM	External
1	1	1	1+p

Cycles for a Repeat (RPT) Execution of an CMPR Instruction			
ROM	DARAM	SARAM	External
n	n	n	n+p

Example CMPR 2 ; (current AR) > (AR0)?

	Before Instruction		After Instruction
ARP	4	ARP	4
AR0	0FFFFh	AR0	0FFFFh
AR4	7FFFh	AR4	7FFFh
TC	1	TC	0

Cycles**Cycles for a Single DMOV Instruction**

Operand	Program			
	ROM	DARAM	SARAM	External
DARAM	1	1	1	1+p
SARAM	1	1	1, 3 [†]	1+p
External [‡]	2+2d	2+2d	2+2d	5+2d+p

[†] If the operand and the code are in the same SARAM block

[‡] If used on external memory, DMOV reads the specified memory location but performs no operations.

Cycles for a Repeat (RPT) Execution of a DMOV Instruction

Operand	Program			
	ROM	DARAM	SARAM	External
DARAM	n	n	n	n+p
SARAM	2n-2	2n-2	2n-2, 2n+1 [†]	2n-2+p
External [‡]	4n-2+2nd	4n-2+2nd	4n-2+2nd	4n+1+2nd+p

[†] If the operand and the code are in the same SARAM block

[‡] If used on external memory, DMOV reads the specified memory location but performs no operations.

Example 1

DMOV DAT8 ; (DP = 6)

	Before Instruction		After Instruction
Data Memory 308h	43h	Data Memory 308h	43h
Data Memory 309h	2h	Data Memory 309h	43h

Example 2

DMOV *, AR1

	Before Instruction		After Instruction
ARP	0	ARP	1
AR0	30Ah	AR0	30Ah
Data Memory 30Ah	40h	Data Memory 30Ah	40h
Data Memory 30Bh	41h	Data Memory 30Bh	40h

Syntax **IDLE**

Operands None

Opcode

15	14	13	12	11	10	9	8	7	6	5	4	3	2	1	0
1	0	1	1	1	1	1	0	0	0	1	0	0	0	1	0

Execution Increment PC, then wait for unmasked or nonmaskable hardware interrupt.

Status Bits *Affected by*
INTM

Description The IDLE instruction forces the program being executed to halt until the CPU receives a request from an unmasked hardware interrupt (external or internal), $\overline{\text{NMI}}$, or reset. Execution of the IDLE instruction causes the 'C2xx to enter a power-down mode. The PC is incremented once before the 'C2xx enters power down; it is not incremented during the idle state. On-chip peripherals remain active; thus, their interrupts are among those that can wake the processor.

The idle state is exited by an unmasked interrupt even if INTM is 1. (INTM, the interrupt mode bit of status register ST0, normally disables maskable interrupts when it is set to 1.) When the idle state is exited by an unmasked interrupt, the CPU's next action, however, depends on INTM:

- If INTM is 0, the program branches to the corresponding interrupt service routine.
- If INTM is 1, the program continues executing at the instruction following the IDLE.

$\overline{\text{NMI}}$ and reset are not maskable; therefore, if the idle state is exited by $\overline{\text{NMI}}$ or reset, the corresponding interrupt service routine will be executed, regardless of INTM.

Words 1

Cycles

Cycles for a Single IDLE Instruction			
ROM	DARAM	SARAM	External
1	1	1	1+p

Example

```
IDLE      ;The processor idles until a hardware reset,
          ;a hardware NMI, or an unmasked interrupt
          ;occurs.
```

Cycles **Cycles for a Single IN Instruction**

Operand	Program			
	ROM	DARAM	SARAM	External
Destination: DARAM	$2+i_{src}$	$2+i_{src}$	$2+i_{src}$	$3+i_{src}+2p_{code}$
Destination: SARAM	$2+i_{src}$	$2+i_{src}$	$2+i_{src}$ $3+i_{src}^\dagger$	$3+i_{src}+2p_{code}$
Destination: External	$3+d_{dst}+i_{src}$	$3+d_{dst}+i_{src}$	$3+d_{dst}+i_{src}$	$6+d_{dst}+i_{src}+2p_{code}$

[†] If the operand and the code are in the same SARAM block

Cycles for a Repeat (RPT) Execution of an IN Instruction

Operand	Program			
	ROM	DARAM	SARAM	External
Destination: DARAM	$2n+n_{io_{src}}$	$2n+n_{io_{src}}$	$2n+n_{io_{src}}$	$2n+1+n_{io_{src}}+2p_{code}$
Destination: SARAM	$2n+n_{io_{src}}$	$2n+n_{io_{src}}$	$2n+n_{io_{src}}$ $2n+2+n_{io_{src}}^\dagger$	$2n+1+n_{io_{src}}+2p_{code}$
Destination: External	$4n-1+nd_{dst}+n_{io_{src}}$	$4n-1+nd_{dst}+n_{io_{src}}$	$4n-1+nd_{dst}+n_{io_{src}}$	$4n+2+nd_{dst}+n_{io_{src}}+2p_{code}$

[†] If the operand and the code are in the same SARAM block

Example 1 IN 7,1000h ;Read in word from peripheral on
 ;port address 1000h. Store word in
 ;data memory location 307h (DP=6).

Example 2 IN *,5h ;Read in word from peripheral on
 ;port address 5h. Store word in
 ;data memory location specified by
 ;current auxiliary register.

Syntax **INTR K****Operands** K: Value from 0 to 31 that indicates the interrupt vector location to branch to**Opcode**

15	14	13	12	11	10	9	8	7	6	5	4	3	2	1	0
1	0	1	1	1	1	1	0	0	1	1	K				

Execution (PC) + 1 → stack
corresponding interrupt vector location → PC**Status Bits** Affects
INTM

This instruction is not affected by INTM.

Description The processor has locations for 32 interrupt vectors; each location is represented by a value K from 0 to 31. The INTR instruction is a software interrupt that transfers program control to the program-memory address specified by K. The vector at that address then leads to the corresponding interrupt service routine. Thus, the instruction allows any one of the interrupt service routines to be executed from your software. For a list of interrupts and their corresponding K values, see subsection 5.6.2, *Interrupt Table*, on page 5-16. During execution of the instruction, the value PC + 1 (the return address) is pushed onto the stack. Neither the INTM bit nor the interrupt masks affect the INTR instruction. An INTR for the external interrupts looks exactly like an external interrupt (an interrupt acknowledge is generated, and maskable interrupts are globally disabled by setting INTM = 1).**Words** 1**Cycles**

Cycles for a Single INTR Instruction			
ROM	DARAM	SARAM	External
4	4	4	4+3p†

† The processor performs speculative fetching by reading two additional instruction words. If the PC discontinuity is taken, these two instruction words are discarded.

Example

```
INTR      3           ;PC + 1 is pushed onto the stack.
                   ;Then control is passed to program
                   ;memory location 6h.
```

Syntax	LACC <i>dma</i> [, <i>shift</i>]	Direct addressing
	LACC <i>dma</i> , 16	Direct with left shift of 16
	LACC <i>ind</i> [, <i>shift</i> [, AR <i>n</i>]]	Indirect addressing
	LACC <i>ind</i> , 16 [, AR <i>n</i>]	Indirect with left shift of 16
	LACC # <i>lk</i> [, <i>shift</i>]	Long immediate addressing

Operands	dma :	7 LSBs of the data-memory address
	shift :	Left shift value from 0 to 15 (defaults to 0)
	n :	Value from 0 to 7 designating the next auxiliary register
	lk :	16-bit long immediate value
	ind :	Select one of the following seven options: * *+ *− *0+ *0− *BR0+ *BR0−

Opcode

LACC *dma* [, *shift*]

15	14	13	12	11	10	9	8	7	6	5	4	3	2	1	0
0	0	0	1	shift				0	dma						

LACC *dma*, **16**

15	14	13	12	11	10	9	8	7	6	5	4	3	2	1	0
0	1	1	0	1	0	1	0	0	dma						

LACC *ind* [, *shift* [, **AR***n*]]

15	14	13	12	11	10	9	8	7	6	5	4	3	2	1	0
0	0	0	1	shift				1	ARU	N	NAR				

Note: ARU, N, and NAR are defined in Section 6.3, *Indirect Addressing Mode* (page 6-9).

LACC *ind*, **16** [, **AR***n*]

15	14	13	12	11	10	9	8	7	6	5	4	3	2	1	0
0	1	1	0	1	0	1	0	1	ARU	N	NAR				

Note: ARU, N, and NAR are defined in Section 6.3, *Indirect Addressing Mode* (page 6-9).

LACC **#***lk* [, *shift*]

15	14	13	12	11	10	9	8	7	6	5	4	3	2	1	0
1	0	1	1	1	1	1	1	1	0	0	0	shift			
lk															

Execution	Increment PC, then ...	
	<u>Event</u> (data-memory address) $\times 2^{\text{shift}}$ \rightarrow ACC	<u>Addressing mode</u> Direct or indirect
	(data-memory address) $\times 2^{16}$ \rightarrow ACC	Direct or indirect (shift of 16)
	$lk \times 2^{\text{shift}}$ \rightarrow ACC	Long immediate

Status Bits Affected by
SXM

Description The contents of the specified data-memory address or a 16-bit constant are left shifted and loaded into the accumulator. During shifting, low-order bits are zero filled. High-order bits are sign extended if SXM = 1 and zeroed if SXM = 0.

Words	<u>Words</u> 1	<u>Addressing mode</u> Direct or indirect
	2	Long immediate

Cycles **Cycles for a Single LACC Instruction (Using Direct and Indirect Addressing)**

Operand	Program			
	ROM	DARAM	SARAM	External
DARAM	1	1	1	1+p
SARAM	1	1	1, 2 [†]	1+p
External	1+d	1+d	1+d	2+d+p

[†] If the operand and the code are in the same SARAM block

Cycles for a Repeat (RPT) Execution of an LACC Instruction (Using Direct and Indirect Addressing)

Operand	Program			
	ROM	DARAM	SARAM	External
DARAM	n	n	n	n+p
SARAM	n	n	n, n+1 [†]	n+p
External	n+nd	n+nd	n+nd	n+1+p+nd

[†] If the operand and the code are in the same SARAM block

Cycles for a Single LACC Instruction (Using Immediate Addressing)

ROM	DARAM	SARAM	External
2	2	2	2+2p

Syntax

LACL <i>dma</i>	Direct addressing
LACL <i>ind</i> [, AR <i>n</i>]	Indirect addressing
LACL # <i>k</i>	Short immediate

Operands

dma: 7 LSBs of the data-memory address
n: Value from 0 to 7 designating the next auxiliary register
k: 8-bit short immediate value
ind: Select one of the following seven options:
 * *+ *− *0+ *0− *BR0+ *BR0−

Opcode

LACL *dma*

15	14	13	12	11	10	9	8	7	6	5	4	3	2	1	0
0	1	1	0	1	0	0	1	0	dma						

LACL *ind* [, **AR***n*]

15	14	13	12	11	10	9	8	7	6	5	4	3	2	1	0
0	1	1	0	1	0	0	1	1	ARU	N	NAR				

Note: ARU, N, and NAR are defined in Section 6.3, *Indirect Addressing Mode* (page 6-9).

LACL **#***k*

15	14	13	12	11	10	9	8	7	6	5	4	3	2	1	0
1	0	1	1	1	0	0	1	k							

Execution

Increment PC, then ...

<u>Events</u>	<u>Addressing mode</u>
0 → ACC(31:16) (data-memory address) → ACC(15:0)	Direct or indirect
0 → ACC(31:8) k → ACC(7:0)	Short immediate

Status Bits This instruction is not affected by SXM.

Description The contents of the addressed data-memory location or a zero-extended 8-bit constant are loaded into the 16 low-order bits of the accumulator. The upper half of the accumulator is zeroed. The data is treated as an unsigned 16-bit number rather than a 2s-complement number. There is no sign extension of the operand with this instruction, regardless of the state of SXM.

Words 1

Cycles

Cycles for a Single LACL Instruction (Using Direct and Indirect Addressing)

Operand	Program			
	ROM	DARAM	SARAM	External
DARAM	1	1	1	1+p
SARAM	1	1	1, 2†	1+p
External	1+d	1+d	1+d	2+d+p

† If the operand and the code are in the same SARAM block

Cycles for a Repeat (RPT) Execution of an LACL Instruction (Using Direct and Indirect Addressing)

Operand	Program			
	ROM	DARAM	SARAM	External
DARAM	n	n	n	n+p
SARAM	n	n	n, n+1†	n+p
External	n+nd	n+nd	n+nd	n+1+p+nd

† If the operand and the code are in the same SARAM block

Cycles for a Single LACL Instruction (Using Immediate Addressing)

ROM	DARAM	SARAM	External
1	1	1	1+p

Example 1

LACL 1 ; (DP = 6: addresses 0300h-037Fh)

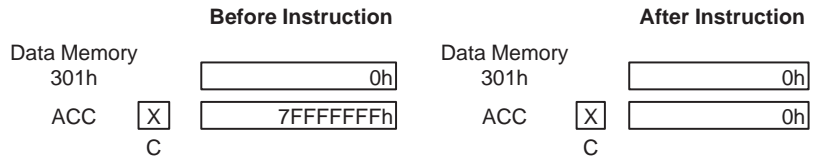

Example 2

LACL *- , AR4

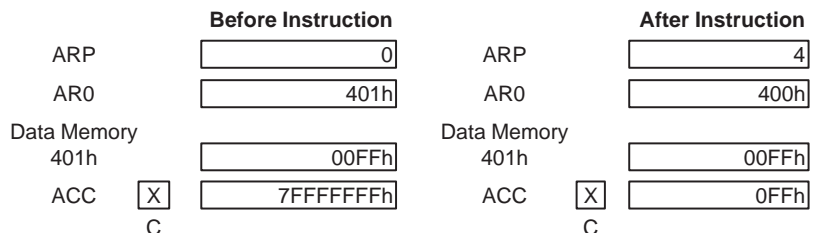

Example 3

LACL #10h



Cycles

Cycles for a Single LACT Instruction

Operand	Program			
	ROM	DARAM	SARAM	External
DARAM	1	1	1	1+p
SARAM	1	1	1, 2†	1+p
External	1+d	1+d	1+d	2+d+p

† If the operand and the code are in the same SARAM block

Cycles for a Repeat (RPT) Execution of an LACT Instruction

Operand	Program			
	ROM	DARAM	SARAM	External
DARAM	n	n	n	n+p
SARAM	n	n	n, n+1†	n+p
External	n+nd	n+nd	n+nd	n+1+p+nd

† If the operand and the code are in the same SARAM block

Example 1

```
LACT    1                ; (DP = 6: addresses 0300h-037Fh,
                        ; SXM = 0)
```

	Before Instruction		After Instruction	
Data Memory 301h	<input type="text" value="1376h"/>	Data Memory 301h	<input type="text" value="1376h"/>	
TREG	<input type="text" value="14h"/>	TREG	<input type="text" value="14h"/>	
ACC <input type="checkbox"/> C	<input type="text" value="98F7EC83h"/>	ACC <input type="checkbox"/> C	<input type="text" value="13760h"/>	

Example 2

```
LACT    *- ,AR3        ; (SXM = 1)
```

	Before Instruction		After Instruction	
ARP	<input type="text" value="1"/>	ARP	<input type="text" value="3"/>	
AR1	<input type="text" value="310h"/>	AR1	<input type="text" value="30Fh"/>	
Data Memory 310h	<input type="text" value="0FF00h"/>	Data Memory 310h	<input type="text" value="0FF00h"/>	
TREG	<input type="text" value="11h"/>	TREG	<input type="text" value="11h"/>	
ACC <input type="checkbox"/> C	<input type="text" value="098F7EC83h"/>	ACC <input type="checkbox"/> C	<input type="text" value="0FFFFFFE00h"/>	

Syntax	LAR AR_x, dma	Direct addressing
	LAR AR_x, ind [, AR_n]	Indirect addressing
	LAR AR_x, #k	Short immediate addressing
	LAR AR_x, #lk	Long immediate addressing

Operands	x:	Value from 0 to 7 designating the auxiliary register to be loaded
	dma:	7 LSBs of the data-memory address
	k:	8-bit short immediate value
	lk:	16-bit long immediate value
	n:	Value from 0 to 7 designating the next auxiliary register
	ind:	Select one of the following seven options: * *+ *− *0+ *0− *BR0+ *BR0−

Opcode	LAR AR_x, dma
	15 14 13 12 11 10 9 8 7 6 5 4 3 2 1 0
	0 0 0 0 0 x 0 dma

	LAR AR_x, ind [, AR_n]
	15 14 13 12 11 10 9 8 7 6 5 4 3 2 1 0
	0 0 0 0 0 x 1 ARU N NAR

Note: ARU, N, and NAR are defined in Section 6.3, *Indirect Addressing Mode* (page 6-9).

	LAR AR_x, #k
	15 14 13 12 11 10 9 8 7 6 5 4 3 2 1 0
	1 0 1 1 0 x k

	LAR AR_x, #lk
	15 14 13 12 11 10 9 8 7 6 5 4 3 2 1 0
	1 0 1 1 1 1 1 1 0 0 0 0 1 x
	lk

Execution	Increment PC, then ...	
	<u>Event</u> (data-memory address) → AR _x	<u>Addressing mode</u> Direct or indirect
	k → AR _x	Short immediate
	lk → AR _x	Long immediate

Status Bits None

Description

The contents of the specified data-memory address or an 8-bit or 16-bit constant are loaded into the specified auxiliary register (ARx). The specified constant is acted upon like an unsigned integer, regardless of the value of SXM.

The LAR and SAR (store auxiliary register) instructions can be used to load and store the auxiliary registers during subroutine calls and interrupts. If an auxiliary register is not being used for indirect addressing, LAR and SAR enable the register to be used as an additional storage register, especially for swapping values between data-memory locations without affecting the contents of the accumulator.

WordsWords

1

Addressing mode

Direct, indirect or short immediate

2

Long immediate

Cycles**Cycles for a Single LAR Instruction (Using Direct and Indirect Addressing)**

Operand	Program			
	ROM	DARAM	SARAM	External
DARAM	2	2	2	2+p _{code}
SARAM	2	2	2, 3 [†]	2+p _{code}
External	2+d _{src}	2+d _{src}	2+d _{src}	3+d _{src} +p _{code}

[†] If the operand and the code are in the same SARAM block

Cycles for a Repeat (RPT) Execution of an LAR Instruction (Using Direct and Indirect Addressing)

Operand	Program			
	ROM	DARAM	SARAM	External
DARAM	2n	2n	2n	2n+p _{code}
SARAM	2n	2n	2n, 2n+1 [†]	2n+p _{code}
External	2n+nd _{src}	2n+nd _{src}	2n+nd _{src}	2n+1+nd _{src} p _{code}

[†] If the operand and the code are in the same SARAM block

Cycles for a Single LAR Instruction (Using Short Immediate Addressing)

ROM	DARAM	SARAM	External
2	2	2	2+p _{code}

Cycles for a Single LAR Instruction (Using Long Immediate Addressing)

ROM	DARAM	SARAM	External
2	2	2	2+2p

Example 1

LAR	AR0, 16 ; (DP = 6: addresses 0300h-037Fh)			
	Before Instruction		After Instruction	
	Data Memory 310h	18h	Data Memory 310h	18h
	AR0	6h	AR0	18h

Example 2

LAR	AR4, *-			
	Before Instruction		After Instruction	
	ARP	4	ARP	4
	Data Memory 300h	32h	Data Memory 300h	32h
	AR4	300h	AR4	32h

Note:

LAR in the indirect addressing mode ignores any AR modifications if the AR specified by the instruction is the same as that pointed to by the ARP. Therefore, in Example 2, AR4 is not decremented after the LAR instruction.

Example 3

LAR	AR4, #01h			
	Before Instruction		After Instruction	
	AR4	0FF09h	AR4	01h

Example 4

LAR	AR6, #3FFFh			
	Before Instruction		After Instruction	
	AR6	0h	AR6	3FFFh

Syntax

LDP <i>dma</i>	Direct addressing
LDP <i>ind</i> [, AR<i>n</i>]	Indirect addressing
LDP #<i>k</i>	Short immediate addressing

Operands

dma:	7 LSBs of the data-memory address
n:	Value from 0 to 7 designating the next auxiliary register
k:	9-bit short immediate value
ind:	Select one of the following seven options: * *+ *− *0+ *0− *BR0+ *BR0−

Opcode

LDP *dma*

15	14	13	12	11	10	9	8	7	6	5	4	3	2	1	0
0	0	0	0	1	1	0	1	0	dma						

LDP *ind* [, AR*n*]

15	14	13	12	11	10	9	8	7	6	5	4	3	2	1	0
0	0	0	0	1	1	0	1	1	ARU	N	NAR				

Note: ARU, N, and NAR are defined in Section 6.3, *Indirect Addressing Mode* (page 6-9).

LDP #*k*

15	14	13	12	11	10	9	8	7	6	5	4	3	2	1	0
1	0	1	1	1	1	0	k								

Execution

Increment PC, then ...	
<u>Event</u>	<u>Addressing mode</u>
Nine LSBs of (data-memory address) → DP	Direct or indirect
k → DP	Short immediate

Status Bits

Affects
DP

Description

The nine LSBs of the contents of the addressed data-memory location or a 9-bit immediate value is loaded into the data page pointer (DP) of status register ST0. The DP can also be loaded by the LST instruction.

In direct addressing, the 9-bit DP and the 7-bit value specified in the instruction (*dma*) are concatenated to form the 16-bit data-memory address accessed by the instruction. The DP provides the 9 MSBs, and *dma* provides the 7 LSBs.

Words 1

Cycles

Cycles for a Single LDP Instruction (Using Direct and Indirect Addressing)

Operand	Program			
	ROM	DARAM	SARAM	External
DARAM	2	2	2	2+p _{code}
SARAM	2	2	2, 3†	2+p _{code}
External	2+d _{src}	2+d _{src}	2+d _{src}	3+d _{src} +p _{code}

† If the operand and the code are in the same SARAM block

Cycles for a Repeat (RPT) Execution of an LDP Instruction (Using Direct and Indirect Addressing)

Operand	Program			
	ROM	DARAM	SARAM	External
DARAM	2n	2n	2n	2n+p _{code}
SARAM	2n	2n	2n, 2n+1†	2n+p _{code}
External	2n+nd _{src}	2n+nd _{src}	2n+nd _{src}	2n+1+nd _{src} p _{code}

† If the operand and the code are in the same SARAM block

Cycles for a Single LDP Instruction (Using Short Immediate Addressing)

ROM	DARAM	SARAM	External
2	2	2	2+p _{code}

Example 1

LDP 127 ; (DP = 511: addresses FF80h-FFFFh)

		Before Instruction			After Instruction
Data Memory	FFFFh	FEDCh	Data Memory	FFFFh	FEDCh
DP		1FFh	DP		0DCh

Example 2

LDP #0h

		Before Instruction			After Instruction
DP		1FFh	DP		0h

Example 3

LDP *, AR5

		Before Instruction			After Instruction
ARP		4	ARP		5
AR4		300h	AR4		300h
Data Memory	300h	06h	Data Memory	300h	06h
DP		1FFh	DP		06h

Syntax **LPH** *dma* Direct addressing
LPH *ind* [, **AR***n*] Indirect addressing

Operands *dma*: 7 LSBs of the data-memory address
n: Value from 0 to 7 designating the next auxiliary register
ind: Select one of the following seven options:
 * *+ *- *0+ *0- *BR0+ *BR0-

Opcode

LPH *dma*

15	14	13	12	11	10	9	8	7	6	5	4	3	2	1	0
0	1	1	1	0	1	0	1	0	dma						

LPH *ind* [, **AR***n*]

15	14	13	12	11	10	9	8	7	6	5	4	3	2	1	0
0	1	1	1	0	1	0	1	1	ARU	N	NAR				

Note: ARU, N, and NAR are defined in Section 6.3, *Indirect Addressing Mode* (page 6-9).

Execution Increment PC, then ...
(data-memory address) → PREG (31:16)

Status Bits None

Description The 16 high-order bits of the PREG are loaded with the content of the specified data-memory address. The low-order PREG bits are unaffected.

The LPH instruction can be used for restoring the high-order bits of the PREG after interrupts and subroutine calls.

Words 1

Cycles

Cycles for a Single LPH Instruction

Operand	Program			
	ROM	DARAM	SARAM	External
DARAM	1	1	1	1+p
SARAM	1	1	1, 2†	1+p
External	1+d	1+d	1+d	2+d+p

† If the operand and the code are in the same SARAM block

Cycles for a Repeat (RPT) Execution of an LPH Instruction

Operand	Program			
	ROM	DARAM	SARAM	External
DARAM	n	n	n	n+p
SARAM	n	n	n, n+1†	n+p
External	n+nd	n+nd	n+nd	n+1+p+nd

† If the operand and the code are in the same SARAM block

Example 1

LPH	DAT0	; (DP = 4)	
		Before Instruction	After Instruction
	Data Memory		Data Memory
	200h	0F79Ch	200h 0F79Ch
	PREG	30079844h	PREG 0F79C9844h

Example 2

LPH	* , AR6		
		Before Instruction	After Instruction
	ARP	5	ARP 6
	AR5	200h	AR5 200h
	Data Memory		Data Memory
	200h	0F79Ch	200h 0F79Ch
	PREG	30079844h	PREG 0F79C9844h

Figure 7–4. LST #1 Operation

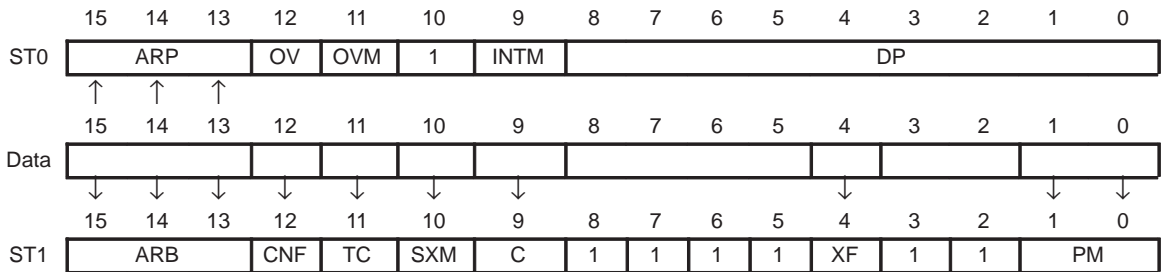

Status Bits

Affects

ARB, ARP, OV, OVM, DP, CNF, TC, SXM, C, XF, and PM

This instruction does not affect INTM.

Description

The specified status register (ST0 or ST1) is loaded with the addressed data-memory value. Note the following points:

- The LST #0 operation does not affect the ARB field in the ST1 register, even though a new ARP is loaded.
- During the LST #1 operation, the value loaded into ARB is also loaded into ARP.
- If a next AR value is specified as an operand in the indirect addressing mode, this operand is ignored. ARP is loaded with the three MSBs of the value contained in the addressed data-memory location.
- Reserved bit values in the status registers are always read as 1s. Writes to these bits have no effect.

The LST instruction can be used for restoring the status registers after subroutine calls and interrupts.

Words

1

Cycles

Cycles for a Single LST Instruction

Operand	Program			
	ROM	DARAM	SARAM	External
DARAM	2	2	2	2+p _{code}
SARAM	2	2	2, 3†	2+p _{code}
External	2+d _{src}	2+d _{src}	2+d _{src}	3+d _{src} +p _{code}

† If the operand and the code are in the same SARAM block

Cycles for a Repeat (RPT) Execution of an LST Instruction

Operand	Program			
	ROM	DARAM	SARAM	External
DARAM	2n	2n	2n	2n+p _{code}
SARAM	2n	2n	2n, 2n+1 [†]	2n+p _{code}
External	2n+nd _{src}	2n+nd _{src}	2n+nd _{src}	2n+1+nd _{src} +p _{code}

[†] If the operand and the code are in the same SARAM block

Example 1

```

MAR    *,AR0
LST    #0,*,AR1 ;The data memory word addressed by the
                ;contents of auxiliary register AR0 is
                ;loaded into status register ST0,except
                ;for the INTM bit. Note that even
                ;though a next ARP value is specified,
                ;that value is ignored. Also note that
                ;the old ARP is not loaded into the
                ;ARB.

```

Example 2

```

LST    #0,60h ;(DP = 0)

```

		Before Instruction			After Instruction
Data Memory	60h	2404h	Data Memory	60h	2404h
	ST0	6E00h		ST0	2604h
	ST1	05ECh		ST1	05ECh

Example 3

```

LST    #0,*-,AR1

```

		Before Instruction			After Instruction
ARP		4	ARP		7
AR4		3FFh	AR4		3FEh
Data Memory	3FFh	EE04h	Data Memory	3FFh	EE04h
	ST0	EE00h		ST0	EE04h
	ST1	F7ECh		ST1	F7ECh

Example 4

LST #1,00h ;(DP = 6)
 ;Note that the ARB is loaded with
 ;the new ARP value.

	Before Instruction		After Instruction		
Data Memory		Data Memory			
300h	<table border="1"><tr><td>E1BCh</td></tr></table>	E1BCh	300h	<table border="1"><tr><td>E1BCh</td></tr></table>	E1BCh
E1BCh					
E1BCh					
ST0	<table border="1"><tr><td>0406h</td></tr></table>	0406h	ST0	<table border="1"><tr><td>E406h</td></tr></table>	E406h
0406h					
E406h					
ST1	<table border="1"><tr><td>09ECh</td></tr></table>	09ECh	ST1	<table border="1"><tr><td>E1FCh</td></tr></table>	E1FCh
09ECh					
E1FCh					

Cycles for a Repeat (RPT) Execution of an LT Instruction

Operand	Program			
	ROM	DARAM	SARAM	External
DARAM	n	n	n	n+p
SARAM	n	n	n, n+1†	n+p
External	n+nd	n+nd	n+nd	n+1+p+nd

† If the operand and the code are in the same SARAM block

Example 1

LT 24 ; (DP = 8: addresses 0400h-047Fh)

	Before Instruction		After Instruction	
Data Memory 418h	62h	Data Memory 418h	62h	
TREG	3h	TREG	62h	

Example 2

LT *, AR3

	Before Instruction		After Instruction	
ARP	2	ARP	3	
AR2	418h	AR2	418h	
Data Memory 418h	62h	Data Memory 418h	62h	
TREG	3h	TREG	62h	

Cycles for a Repeat (RPT) Execution of an LTA Instruction

Operand	Program			
	ROM	DARAM	SARAM	External
DARAM	n	n	n	n+p
SARAM	n	n	n, n+1†	n+p
External	n+nd	n+nd	n+nd	n+1+p+nd

† If the operand and the code are in the same SARAM block

Example 1

LTA 36 ; (DP = 6: addresses 0300h-037Fh,
 ; PM = 0: no shift of product)

	Before Instruction		After Instruction	
Data Memory			Data Memory	
324h	<input type="text" value="62h"/>		324h	<input type="text" value="62h"/>
TREG	<input type="text" value="3h"/>		TREG	<input type="text" value="62h"/>
PREG	<input type="text" value="0Fh"/>		PREG	<input type="text" value="0Fh"/>
ACC	<input checked="" type="checkbox"/> <input type="text" value="5h"/>		ACC	<input type="checkbox"/> <input type="text" value="14h"/>
	C			C

Example 2

LTA *, AR5 ; (PM = 0)

	Before Instruction		After Instruction	
ARP	<input type="text" value="4"/>		ARP	<input type="text" value="5"/>
AR4	<input type="text" value="324h"/>		AR4	<input type="text" value="324h"/>
Data Memory			Data Memory	
324h	<input type="text" value="62h"/>		324h	<input type="text" value="62h"/>
TREG	<input type="text" value="3h"/>		TREG	<input type="text" value="62h"/>
PREG	<input type="text" value="0Fh"/>		PREG	<input type="text" value="0Fh"/>
ACC	<input checked="" type="checkbox"/> <input type="text" value="5h"/>		ACC	<input type="checkbox"/> <input type="text" value="14h"/>
	C			C

Words 1
Cycles

Cycles for a Single LTD Instruction

Operand	Program			
	ROM	DARAM	SARAM	External [‡]
DARAM	1	1	1	1+p
SARAM	1	1	1, 3 [†]	1+p
External	2+2d	2+2d	2+2d	5+2d+p

[†] If the operand and the code are in the same SARAM block

[‡] If the LTD instruction is used with external memory, the data move will not occur. (The previous product will be accumulated, and the TREG will be loaded.)

Cycles for a Repeat (RPT) Execution of an LTD Instruction

Operand	Program			
	ROM	DARAM	SARAM	External [‡]
DARAM	n	n	n	n+p
SARAM	2n-2	2n-2	2n-2, 2n+1 [†]	2n-2+p
External	4n-2+2nd	4n-2+2nd	4n-2+2nd	4n+1+2nd+p

[†] If the operand and the code are in the same SARAM block

[‡] If the LTD instruction is used with external memory, the data move will not occur. (The previous product will be accumulated, and the TREG will be loaded.)

Example 1

LTD 126 ; (DP = 7: addresses 0380h-03FFh,
; PM = 0: no shift of product).

	Before Instruction		After Instruction	
Data Memory 3FEh	<input type="text" value=""/>	62h	Data Memory 3FEh	<input type="text" value=""/>
Data Memory 3FFh	<input type="text" value=""/>	0h	Data Memory 3FFh	<input type="text" value=""/>
TREG	<input type="text" value=""/>	3h	TREG	<input type="text" value=""/>
PREG	<input type="text" value=""/>	0Fh	PREG	<input type="text" value=""/>
ACC	<input type="text" value="X"/>	5h	ACC	<input type="text" value="0"/>
	C		C	

Example 2

LTD	*,AR3		;(PM = 0)
		Before Instruction	After Instruction
ARP		1	ARP
AR1		3FEh	AR1
Data Memory 3FEh		62h	Data Memory 3FEh
Data Memory 3FFh		0h	Data Memory 3FFh
TREG		3h	TREG
PREG		0Fh	PREG
ACC	X	5h	ACC
	C		0
			C
			14h

Note: The data move function for LTD can occur only within on-chip data memory RAM blocks.

Cycles for a Repeat (RPT) Execution of an LTP Instruction

Operand	Program			
	ROM	DARAM	SARAM	External
DARAM	n	n	n	n+p
SARAM	n	n	n, n+1†	n+p
External	n+nd	n+nd	n+nd	n+1+p+nd

† If the operand and the code are in the same SARAM block

Example 1

LTP 36 ;(DP = 6: addresses 0300h-037Fh,
 ;PM = 0: no shift of product)

		Before Instruction		After Instruction	
Data Memory	324h	<input type="text" value="62h"/>		Data Memory	324h
TREG		<input type="text" value="3h"/>		TREG	<input type="text" value="62h"/>
PREG		<input type="text" value="0Fh"/>		PREG	<input type="text" value="0Fh"/>
ACC	<input type="checkbox"/> X C	<input type="text" value="5h"/>		ACC	<input type="checkbox"/> X C
					<input type="text" value="0Fh"/>

Example 2

LTP * ,AR5 ;(PM = 0)

		Before Instruction		After Instruction	
ARP		<input type="text" value="2"/>		ARP	<input type="text" value="5"/>
AR2		<input type="text" value="324h"/>		AR2	<input type="text" value="324h"/>
Data Memory	324h	<input type="text" value="62h"/>		Data Memory	324h
TREG		<input type="text" value="3h"/>		TREG	<input type="text" value="62h"/>
PREG		<input type="text" value="0Fh"/>		PREG	<input type="text" value="0Fh"/>
ACC	<input type="checkbox"/> X C	<input type="text" value="5h"/>		ACC	<input type="checkbox"/> X C
					<input type="text" value="0Fh"/>

Cycles for a Repeat (RPT) Execution of an LTS Instruction

Operand	Program			
	ROM	DARAM	SARAM	External
DARAM	n	n	n	n+p
SARAM	n	n	n, n+1 [†]	n+p
External	n+nd	n+nd	n+nd	n+1+p+nd

[†] If the operand and the code are in the same SARAM block

Example 1

```
LTS      DAT36      ;(DP = 6: addresses 0300h-037Fh,
                  ;PM = 0: no shift of product)
```

		Before Instruction		After Instruction	
Data Memory	324h	<input type="text" value="62h"/>	Data Memory	324h	<input type="text" value="62h"/>
TREG		<input type="text" value="3h"/>	TREG		<input type="text" value="62h"/>
PREG		<input type="text" value="0Fh"/>	PREG		<input type="text" value="0Fh"/>
ACC	<input checked="" type="checkbox"/>	<input type="text" value="05h"/>	ACC	<input type="checkbox"/>	<input type="text" value="0FFFFFFF6h"/>
	C			C	

Example 2

```
LTS      *,AR2      ;(PM = 0)
```

		Before Instruction		After Instruction	
ARP		<input type="text" value="1"/>	ARP		<input type="text" value="2"/>
AR1		<input type="text" value="324h"/>	AR1		<input type="text" value="324h"/>
324h		<input type="text" value="62h"/>	324h		<input type="text" value="62h"/>
TREG		<input type="text" value="3h"/>	TREG		<input type="text" value="62h"/>
PREG		<input type="text" value="0Fh"/>	PREG		<input type="text" value="0Fh"/>
ACC	<input checked="" type="checkbox"/>	<input type="text" value="05h"/>	ACC	<input type="checkbox"/>	<input type="text" value="0FFFFFFF6h"/>
	C			C	

Description

The MAC instruction:

- Adds the previous product, shifted as defined by the PM status bits, to the accumulator. The carry bit is set ($C = 1$) if the result of the addition generates a carry and is cleared ($C = 0$) if it does not generate a carry.
- Loads the TREG with the content of the specified data-memory address.
- Multiplies the data-memory value in the TREG by the contents of the specified program-memory address.

The data and program memory locations on the 'C2xx may be any nonreserved on-chip or off-chip memory locations. If the program memory is block B0 of on-chip RAM, the CNF bit must be set to 1.

When the MAC instruction is repeated, the program-memory address contained in the PC is incremented by 1 during each repetition. This makes it possible to access a series of operands in program memory. If you use indirect addressing to specify the data-memory address, a new data-memory address can be accessed during each repetition. If you use the direct addressing mode, the specified data-memory address is a constant; it will not be modified during each repetition.

MAC is useful for long sum-of-products operations because, when repeated, it becomes a single-cycle instruction once the RPT pipeline is started.

Words

2

Cycles

Cycles for a Single MAC Instruction

Operand	ROM	DARAM	SARAM	External
Operand 1: DARAM/ ROM Operand 2: DARAM	3	3	3	$3+2p_{code}$
Operand 1: SARAM Operand 2: DARAM	3	3	3	$3+2p_{code}$
Operand 1: External Operand 2: DARAM	$3+p_{op1}$	$3+p_{op1}$	$3+p_{op1}$	$3+p_{op1}+2p_{code}$
Operand 1: DARAM/ ROM Operand 2: SARAM	3	3	3	$3+2p_{code}$
Operand 1: SARAM Operand 2: SARAM	3 4†	3 4†	3 4†	$3+2p_{code}$ $4+2p_{code}$ †
Operand 1: External Operand 2: SARAM	$3+p_{op1}$	$3+p_{op1}$	$3+p_{op1}$	$3+p_{op1}+2p_{code}$
Operand 1: DARAM/ ROM Operand 2: External	$3+d_{op2}$	$3+d_{op2}$	$3+d_{op2}$	$3+d_{op2}+2p_{code}$
Operand 1: SARAM Operand 2: External	$3+d_{op2}$	$3+d_{op2}$	$3+d_{op2}$	$3+d_{op2}+2p_{code}$
Operand 1: External Operand 2: External	$4+p_{op1}+d_{op2}$	$4+p_{op1}+d_{op2}$	$4+p_{op1}+d_{op2}$	$4+p_{op1}+d_{op2}+2p_{code}$

† If both operands are in the same SARAM block

Cycles for a Repeat (RPT) Execution of an MAC Instruction

Operand	ROM	DARAM	SARAM	External
Operand 1: DARAM/ ROM Operand 2: DARAM	n+2	n+2	n+2	$n+2+2p_{code}$
Operand 1: SARAM Operand 2: DARAM	n+2	n+2	n+2	$n+2+2p_{code}$
Operand 1: External Operand 2: DARAM	$n+2+np_{op1}$	$n+2+np_{op1}$	$n+2+np_{op1}$	$n+2+np_{op1}+2p_{code}$

† If both operands are in the same SARAM block

Cycles for a Repeat (RPT) Execution of an MAC Instruction (Continued)

Operand	ROM	DARAM	SARAM	External
Operand 1: DARAM/ ROM Operand 2: SARAM	n+2	n+2	n+2	n+2+2p _{code}
Operand 1: SARAM Operand 2: SARAM	n+2 2n+2†	n+2 2n+2†	n+2 2n+2†	n+2+2p _{code} 2n+2†
Operand 1: External Operand 2: SARAM	n+2+np _{op1}	n+2+np _{op1}	n+2+np _{op1}	n+2+np _{op1} +2p _{code}
Operand 1: DARAM/ ROM Operand 2: External	n+2+nd _{op2}	n+2+nd _{op2}	n+2+nd _{op2}	n+2+nd _{op2} +2p _{code}
Operand 1: SARAM Operand 2: External	n+2+nd _{op2}	n+2+nd _{op2}	n+2+nd _{op2}	n+2+nd _{op2} +2p _{code}
Operand 1: External Operand 2: External	2n+2+np _{op1} + nd _{op2}	2n+2+np _{op1} +nd _{op2}	2n+2+np _{op1} +nd _{op2}	2n+2+np _{op1} +nd _{op2} + 2p _{code}

† If both operands are in the same SARAM block

Example 1

MAC 0FF00h, 02h ; (DP = 6, PM = 0, CNF = 1)

	Before Instruction	After Instruction
Data Memory 302h	23h	23h
Program Memory FF00h	4h	4h
TREG	45h	23h
PREG	458972h	08Ch
ACC <input checked="" type="checkbox"/> C	723EC41h	0 76975B3h C

Example 2

MAC 0FF00h, *, AR5 ; (PM = 0, CNF = 1)

	Before Instruction	After Instruction
ARP	4	5
AR4	302h	302h
Data Memory 302h	23h	23h
Program Memory FF00h	4h	4h
TREG	45h	23h
PREG	458972h	8Ch
ACC <input checked="" type="checkbox"/> C	723EC41h	0 76975B3h C

Syntax **MACD** *pma, dma* Direct addressing
 MACD *pma, ind [, ARn]* Indirect addressing

Operands *dma*: 7 LSBs of the data-memory address
 pma: 16-bit program-memory address
 n: Value from 0 to 7 designating the next auxiliary register
 ind: Select one of the following seven options:
 * *+ *- *0+ *0- *BR0+ *BR0-

Opcode

MACD *pma, dma*

15	14	13	12	11	10	9	8	7	6	5	4	3	2	1	0
1	0	1	0	0	0	1	1	0	dma						
pma															

MACD *pma, ind [, ARn]*

15	14	13	12	11	10	9	8	7	6	5	4	3	2	1	0
1	0	1	0	0	0	1	1	1	ARU		N	NAR			
pma															

Note: ARU, N, and NAR are defined in Section 6.3, *Indirect Addressing Mode* (page 6-9).

Execution

Increment PC, then . . .
 (PC) → MSTACK
pma → PC
 (ACC) + shifted (PREG) → ACC
 (data-memory address) → TREG
 (data-memory address) × (*pma*) → PREG
 For indirect, modify (current AR) and (ARP) as specified
 (PC) + 1 → PC
 (data-memory address) → data-memory address + 1

While (repeat counter) ≠ 0:
 (ACC) + shifted (PREG) → ACC
 (data-memory address) → TREG
 (data-memory address) × (*pma*) → PREG
 For indirect, modify (current AR) and (ARP) as specified
 (PC) + 1 → PC
 (data-memory address) → data-memory address + 1
 (repeat counter) – 1 → repeat counter

(MSTACK) → PC

Status Bits	<u>Affected by</u> PM and OVM	<u>Affects</u> C and OV
--------------------	----------------------------------	----------------------------

Description The MACD instruction:

- Adds the previous product, shifted as defined by the PM status bits, to the accumulator. The carry bit is set (C = 1) if the result of the addition generates a carry and is cleared (C = 0) if it does not generate a carry.
- Loads the TREG with the content of the specified data-memory address.
- Multiplies the data-memory value in the TREG by the contents of the specified program-memory address.
- Copies the contents of the specified data-memory address to the next higher data-memory address.

The data- and program-memory locations on the 'C2xx may be any nonreserved, on-chip or off-chip memory locations. If the program memory is block B0 of on-chip RAM, the CNF bit must be set to 1. If MACD addresses one of the memory-mapped registers or external memory as a data-memory location, the effect of the instruction is that of a MAC instruction; the data move will not occur (see the DMOV instruction description).

When the MACD instruction is repeated, the program-memory address contained in the PC is incremented by 1 during each repetition. This makes it possible to access a series of operands in program memory. If you use indirect addressing to specify the data-memory address, a new data-memory address can be accessed during each repetition. If you use the direct addressing mode, the specified data-memory address is a constant; it will not be modified during each repetition.

MACD functions in the same manner as MAC, with the addition of a data move for on-chip RAM blocks. This feature makes MACD useful for applications such as convolution and transversal filtering. When used with RPT, MACD becomes a single-cycle instruction once the RPT pipeline is started.

Words 2

Cycles

Cycles for a Single MACD Instruction

Operand	ROM	DARAM	SARAM	External
Operand 1: DARAM/ ROM Operand 2: DARAM	3	3	3	3+2p _{code}
Operand 1: SARAM Operand 2: DARAM	3	3	3	3+2p _{code}

Cycles for a Single MACD Instruction (Continued)

Operand	ROM	DARAM	SARAM	External
Operand 1: External Operand 2: DARAM	$3+p_{op1}$	$3+p_{op1}$	$3+p_{op1}$	$3+p_{op1}+2p_{code}$
Operand 1: DARAM/ ROM Operand 2: SARAM	3	3	3	$3+2p_{code}$
Operand 1: SARAM Operand 2: SARAM	3	3	3 4† 5‡	$3+2p_{code}$ $4+2p_{code}$ †
Operand 1: External Operand 2: SARAM	$3+p_{op1}$	$3+p_{op1}$	$3+p_{op1}$	$3+p_{op1}+2p_{code}$
Operand 1: DARAM/ ROM Operand 2: External§	$3+d_{op2}$	$3+d_{op2}$	$3+d_{op2}$	$3+d_{op2}+2p_{code}$
Operand 1: SARAM Operand 2: External§	$3+d_{op2}$	$3+d_{op2}$	$3+d_{op2}$	$3+d_{op2}+2p_{code}$
Operand 1: External Operand 2: External§	$4+p_{op1}+d_{op2}$	$4+p_{op1}+d_{op2}$	$4+p_{op1}+d_{op2}$	$4+p_{op1}+d_{op2}+2p_{code}$

† If both operands are in the same SARAM block

‡ If both operands and code are in the same SARAM block

§ Data move operation is not performed when operand2 is in external data memory.

Cycles for a Repeat (RPT) Execution of an MACD Instruction

Operand	ROM	DARAM	SARAM	External
Operand 1: DARAM/ ROM Operand 2: DARAM	$n+2$	$n+2$	$n+2$	$n+2+2p_{code}$
Operand 1: SARAM Operand 2: DARAM	$n+2$	$n+2$	$n+2$	$n+2+2p_{code}$
Operand 1: External Operand 2: DARAM	$n+2+np_{op1}$	$n+2+np_{op1}$	$n+2+np_{op1}$	$n+2+np_{op1}+2p_{code}$
Operand 1: DARAM/ ROM Operand 2: SARAM	$2n$	$2n$	$2n$ $2n+2$ †	$2n+2p_{code}$

† If operand 2 and code are in the same SARAM block

‡ If both operands are in the same SARAM block

§ If both operands and code are in the same SARAM block

¶ Data move operation is not performed when operand2 is in external data memory.

Cycles for a Repeat (RPT) Execution of an MACD Instruction (Continued)

Operand	ROM	DARAM	SARAM	External
Operand 1: SARAM	2n	2n	2n	2n+2p _{code}
Operand 2: SARAM	3n‡	3n‡	2n+2† 3n‡ 3n+2§	3n‡
Operand 1: External	2n+np _{op1}	2n+np _{op1}	2n+np _{op1}	2n+np _{op1} +2p _{code}
Operand 2: SARAM			2n+2+np _{op1} †	
Operand 1: DARAM/ ROM	n+2+nd _{op2}	n+2+nd _{op2}	n+2+nd _{op2}	n+2+nd _{op2} +2p _{code}
Operand 2: External¶				
Operand 1: SARAM	n+2+nd _{op2}	n+2+nd _{op2}	n+2+nd _{op2}	n+2+nd _{op2} +2p _{code}
Operand 2: External¶				
Operand 1: External	2n+2+np _{op1} + nd _{op2}	2n+2+np _{op1} +nd _{op2}	2n+2+np _{op1} +nd _{op2}	2n+2+np _{op1} +nd _{op2} + 2p _{code}
Operand 2: External¶				

† If operand 2 and code are in the same SARAM block

‡ If both operands are in the same SARAM block

§ If both operands and code are in the same SARAM block

¶ Data move operation is not performed when operand2 is in external data memory.

Example 1

```
MACD 0FF00h,08h ;(DP = 6: addresses 0300h-037Fh,
;PM = 0: no shift of product,
;CNF = 1: RAM B0 configured to
;program memory).
```

	Before Instruction	After Instruction
Data Memory 308h	23h	23h
Data Memory 309h	18h	23h
Program Memory FF00h	4h	4h
TREG	45h	23h
PREG	458972h	8Ch
ACC <input checked="" type="checkbox"/> C	723EC41h	ACC <input type="checkbox"/> C 76975B3h

Example 2

MACD	0FF00h, *, AR6		; (PM = 0, CNF = 1)
	Before Instruction		After Instruction
ARP	5	ARP	6
AR5	308h	AR5	308h
Data Memory 308h	23h	Data Memory 308h	23h
Data Memory 309h	18h	Data Memory 309h	23h
Program Memory FF00h	4h	Program Memory FF00h	4h
TREG	45h	TREG	23h
PREG	458972h	PREG	8Ch
ACC	X 723EC41h C	ACC	0 76975B3h C

Note: The data move function for MACD can occur only within on-chip data memory RAM blocks.

Words 1
Cycles

Cycles for a Single MAR Instruction			
ROM	DARAM	SARAM	External
1	1	1	1+p

Cycles for a Repeat (RPT) Execution of an MAR Instruction			
ROM	DARAM	SARAM	External
n	n	n	n+p

Example 1

MAR *,AR1 ;Load the ARP with 1.

	Before Instruction		After Instruction
ARP	0	ARP	1
ARB	7	ARB	0

Example 2

MAR *,AR5 ;Increment current auxiliary
 ;register (AR1) and load ARP
 ;with 5.

	Before Instruction		After Instruction
AR1	34h	AR1	35h
ARP	1	ARP	5
ARB	0	ARB	1

Syntax

MPY <i>dma</i>	Direct addressing
MPY <i>ind</i> [, <i>ARn</i>]	Indirect addressing
MPY #<i>k</i>	Short immediate addressing

Operands

dma: 7 LSBs of the data-memory address
n: Value from 0 to 7 designating the next auxiliary register
k: 13-bit short immediate value
ind: Select one of the following seven options:
 * *+ *− *0+ *0− *BR0+ *BR0−

Opcode

MPY *dma*

15	14	13	12	11	10	9	8	7	6	5	4	3	2	1	0
0	1	0	1	0	1	0	0	0	dma						

MPY *ind* [, *ARn*]

15	14	13	12	11	10	9	8	7	6	5	4	3	2	1	0
0	1	0	1	0	1	0	0	1	ARU	N	NAR				

Note: ARU, N, and NAR are defined in Section 6.3, *Indirect Addressing Mode* (page 6-9).

MPY #*k*

15	14	13	12	11	10	9	8	7	6	5	4	3	2	1	0
1	1	0	k												

Execution

Increment PC, then ...

<u>Event</u>	<u>Addressing mode</u>
(TREG) × (data-memory address) → PREG	Direct or indirect
(TREG) × <i>k</i> → PREG	Short immediate

Status Bits None

Description

The contents of TREG are multiplied by the contents of the addressed data memory location. The result is placed in the product register (PREG). With short immediate addressing, TREG is multiplied by a signed 13-bit constant. The short-immediate value is right justified and sign extended before the multiplication, regardless of SXM.

Words 1

Cycles

Cycles for a Single MPY Instruction (Using Direct and Indirect Addressing)

Operand	Program			
	ROM	DARAM	SARAM	External
DARAM	1	1	1	1+p
SARAM	1	1	1, 2†	1+p
External	1+d	1+d	1+d	2+d+p

† If the operand and the code are in the same SARAM block

Cycles for a Repeat (RPT) Execution of an MPY Instruction (Using Direct and Indirect Addressing)

Operand	Program			
	ROM	DARAM	SARAM	External
DARAM	n	n	n	n+p
SARAM	n	n	n, n+1†	n+p
External	n+nd	n+nd	n+nd	n+1+p+nd

† If the operand and the code are in the same SARAM block

Cycles for a Single MPY Instruction (Using Short Immediate Addressing)

ROM	DARAM	SARAM	External
1	1	1	1+p

Example 1

MPY	DAT13	; (DP = 8)	
		Before Instruction	After Instruction
Data Memory	40Dh	<input type="text" value="7h"/>	Data Memory 40Dh <input type="text" value="7h"/>
TREG		<input type="text" value="6h"/>	TREG <input type="text" value="6h"/>
PREG		<input type="text" value="36h"/>	PREG <input type="text" value="2Ah"/>

Example 2 MPY *, AR2

	Before Instruction		After Instruction
ARP	1	ARP	2
AR1	40Dh	AR1	40Dh
Data Memory		Data Memory	
40Dh	7h	40Dh	7h
TREG	6h	TREG	6h
PREG	36h	PREG	2Ah

Example 3 MPY #031h

	Before Instruction		After Instruction
TREG	2h	TREG	2h
PREG	36h	PREG	62h

Syntax **MPYA** *dma* Direct addressing
MPYA *ind* [, **AR***n*] Indirect addressing

Operands *dma*: 7 LSBs of the data-memory address
n: Value from 0 to 7 designating the next auxiliary register
ind: Select one of the following seven options:
 * *+ *- *0+ *0- *BR0+ *BR0-

Opcode

MPYA *dma*

15	14	13	12	11	10	9	8	7	6	5	4	3	2	1	0
0	1	0	1	0	0	0	0	0	dma						

MPYA *ind* [, **AR***n*]

15	14	13	12	11	10	9	8	7	6	5	4	3	2	1	0
0	1	0	1	0	0	0	0	1	ARU		N	NAR			

Note: ARU, N, and NAR are defined in Section 6.3, *Indirect Addressing Mode* (page 6-9).

Execution Increment PC, then ...
 (ACC) + shifted (PREG) → ACC
 (TREG) × (data-memory address) → PREG

Status Bits *Affected by* *Affects*
 PM and OVM C and OV

Description The contents of TREG are multiplied by the contents of the addressed data memory location. The result is placed in the product register (PREG). The previous product, shifted as defined by the PM status bits, is also added to the accumulator.

Words 1

Cycles

Cycles for a Single MPYA Instruction

Operand	Program			
	ROM	DARAM	SARAM	External
DARAM	1	1	1	1+p
SARAM	1	1	1, 2†	1+p
External	1+d	1+d	1+d	2+d+p

† If the operand and the code are in the same SARAM block

Cycles for a Repeat (RPT) Execution of an MPYA Instruction

Operand	Program			
	ROM	DARAM	SARAM	External
DARAM	n	n	n	n+p
SARAM	n	n	n, n+1†	n+p
External	n+nd	n+nd	n+nd	n+1+p+nd

† If the operand and the code are in the same SARAM block

Example 1

```
MPYA    DAT13    ; (DP = 6, PM = 0)
```

		Before Instruction			After Instruction
Data Memory			Data Memory		
30Dh		7h	30Dh		7h
TREG		6h	TREG		6h
PREG		36h	PREG		2Ah
ACC	X	54h	ACC	0	8Ah
	C			C	

Example 2

```
MPYA    *,AR4    ; (PM = 0)
```

		Before Instruction			After Instruction
ARP		3	ARP		4
AR3		30Dh	AR3		30Dh
Data Memory			Data Memory		
30Dh		7h	30Dh		7h
TREG		6h	TREG		6h
PREG		36h	PREG		2Ah
ACC	X	54h	ACC	0	8Ah
	C			C	

Syntax **MPYS** *dma* Direct addressing
MPYS *ind* [, **AR***n*] Indirect addressing

Operands *dma*: 7 LSBs of the data-memory address
n: Value from 0 to 7 designating the next auxiliary register
ind: Select one of the following seven options:
 * *+ *- *0+ *0- *BR0+ *BR0-

Opcode

MPYS *dma*

15	14	13	12	11	10	9	8	7	6	5	4	3	2	1	0
0	1	0	1	0	0	0	1	0	dma						

MPYS *ind* [, **AR***n*]

15	14	13	12	11	10	9	8	7	6	5	4	3	2	1	0
0	1	0	1	0	0	0	1	1	ARU		N	NAR			

Note: ARU, N, and NAR are defined in Section 6.3, *Indirect Addressing Mode* (page 6-9).

Execution Increment PC, then ...
 (ACC) – shifted (PREG) → ACC
 (TREG) × (data-memory address) → PREG

Status Bits *Affected by* *Affects*
 PM and OVM C and OV

Description The contents of TREG are multiplied by the contents of the addressed data memory location. The result is placed in the product register (PREG). The previous product, shifted as defined by the PM status bits, is also subtracted from the accumulator, and the result is placed in the accumulator.

Words 1

Cycles

Cycles for a Single MPYS Instruction

Operand	Program			
	ROM	DARAM	SARAM	External
DARAM	1	1	1	1+p
SARAM	1	1	1, 2†	1+p
External	1+d	1+d	1+d	2+d+p

† If the operand and the code are in the same SARAM block

Cycles for a Repeat (RPT) Execution of an MPYS Instruction

Operand	Program			
	ROM	DARAM	SARAM	External
DARAM	n	n	n	n+p
SARAM	n	n	n, n+1†	n+p
External	n+nd	n+nd	n+nd	n+1+p+nd

† If the operand and the code are in the same SARAM block

Example 1

```
MPYS    DAT13    ; (DP = 6, PM = 0)
```

		Before Instruction			After Instruction
Data Memory			Data Memory		
30Dh		7h	30Dh		7h
TREG		6h	TREG		6h
PREG		36h	PREG		2Ah
ACC	X	54h	ACC	1	1Eh
	C			C	

Example 2

```
MPYS    *,AR5    ; (PM = 0)
```

		Before Instruction			After Instruction
ARP		4	ARP		5
AR4		30Dh	AR4		30Dh
Data Memory			Data Memory		
30Dh		7h	30Dh		7h
TREG		6h	TREG		6h
PREG		36h	PREG		2Ah
ACC	X	54h	ACC	1	1Eh
	C			C	

Cycles

Cycles for a Single MPYU Instruction

Operand	Program			
	ROM	DARAM	SARAM	External
DARAM	1	1	1	1+p
SARAM	1	1	1, 2†	1+p
External	1+d	1+d	1+d	2+d+p

† If the operand and the code are in the same SARAM block

Cycles for a Repeat (RPT) Execution of an MPYU Instruction

Operand	Program			
	ROM	DARAM	SARAM	External
DARAM	n	n	n	n+p
SARAM	n	n	n, n+1†	n+p
External	n+nd	n+nd	n+nd	n+1+p+nd

† If the operand and the code are in the same SARAM block

Example 1

MPYU 16 ; (DP = 4: addresses 0200h–027Fh)

	Before Instruction		After Instruction
Data Memory 210h	0FFFFh	Data Memory 210h	0FFFFh
TREG	0FFFFh	TREG	0FFFFh
PREG	1h	PREG	0FFFE0001h

Example 2

MPYU *, AR6

	Before Instruction		After Instruction
ARP	5	ARP	6
AR5	210h	AR5	210h
Data Memory 210h	0FFFFh	Data Memory 210h	0FFFFh
TREG	0FFFFh	TREG	0FFFFh
PREG	1h	PREG	0FFFE0001h

Syntax **NEG**

Operands None

Opcode

	15	14	13	12	11	10	9	8	7	6	5	4	3	2	1	0
	1	0	1	1	1	1	1	0	0	0	0	0	0	0	1	0

Execution Increment PC, then ...
 (ACC) × -1 → ACC

Status Bits Affected by Affects
 OVM C and OV

Description The content of the accumulator is replaced with its arithmetic complement (2s complement). The OV bit is set when taking the NEG of 8000 0000h. If OVM = 1, the accumulator content is replaced with 7FFF FFFFh. If OVM = 0, the result is 8000 0000h. The carry bit (C) is cleared to 0 by this instruction for all nonzero values of the accumulator, and is set to 1 if the accumulator equals zero.

Words 1

Cycles

Cycles for a Single NEG Instruction			
ROM	DARAM	SARAM	External
1	1	1	1+p
Cycles for a Repeat (RPT) Execution of an NEG Instruction			
ROM	DARAM	SARAM	External
n	n	n	n+p

Example 1 NEG ; (OVM = X) Convert -3544 to +3544

Before Instruction		After Instruction			
ACC	[X]	0FFFFFF228h	ACC	[0]	0DD8h
	C			C	
	[X]			[X]	
	OV			OV	

Example 2 NEG ; (OVM = 0)

Before Instruction		After Instruction			
ACC	[X]	080000000h	ACC	[0]	080000000h
	C			C	
	[X]			[1]	
	OV			OV	

Example 3

NEG ; (OVM = 1)

		Before Instruction			After Instruction
ACC	<input checked="" type="checkbox"/>	08000000h	ACC	<input type="checkbox"/>	7FFFFFFh
	C			C	
	<input checked="" type="checkbox"/>			<input type="checkbox"/>	
	OV			OV	

Syntax **NMI**

Operands None

Opcode

15	14	13	12	11	10	9	8	7	6	5	4	3	2	1	0
1	0	1	1	1	1	1	0	0	1	0	1	0	0	1	0

Execution (PC) + 1 → stack
 24h → PC
 1 → INTM

Status Bits Affects
 INTM

This instruction is not affected by INTM.

Description The NMI instruction forces the program counter to the nonmaskable interrupt vector located at 24h. This instruction has the same effect as the hardware nonmaskable interrupt NMI.

Words 1

Cycles

Cycles for a Single NMI Instruction			
ROM	DARAM	SARAM	External
4	4	4	4+3p†

† The 'C2xx performs speculative fetching by reading two additional instruction words. If the PC discontinuity is taken, these two instruction words are discarded.

Example NMI ;PC + 1 is pushed onto the stack, and then
 ;control is passed to program memory location
 ;24h.

Syntax **NORM** *ind* Indirect addressing

Operands *ind*: Select one of the following seven options:
 * *+ *- *0+ *0- *BR0+ *BR0-

Opcode **NORM** *ind*

15	14	13	12	11	10	9	8	7	6	5	4	3	2	1	0
1	0	1	0	0	0	0	0	1	ARU		N	NAR			

Note: ARU, N, and NAR are defined in Section 6.3, *Indirect Addressing Mode* (page 6-9).

Execution Increment PC, then ...

If (ACC) = 0:
 Then TC → 1;
 Else, if (ACC(31)) XOR (ACC(30)) = 0:
 Then TC → 0,
 (ACC) × 2 → ACC
 Modify (current AR) as specified;
 Else TC → 1.

Status Bits Affects
 TC

Description The NORM instruction normalizes a signed number that is contained in the accumulator. Normalizing a fixed-point number separates it into a mantissa and an exponent. By finding the magnitude of the sign-extended number. An exclusive-OR operation is performed on accumulator bits 31 and 30 to determine if bit 30 is part of the magnitude or part of the sign extension. If they are the same, they are both sign bits, and the accumulator is left shifted to eliminate the extra sign bit.

The current AR is modified as specified to generate the magnitude of the exponent. It is assumed that the current AR is initialized before normalization begins. The default modification of the current AR is an increment.

Multiple executions of the NORM instruction may be required to completely normalize a 32-bit number in the accumulator. Although using NORM with RPT does not cause execution of NORM to fall out of the repeat loop automatically when the normalization is complete, no operation is performed for the remainder of the repeat loop. NORM functions on both positive and negative 2s-complement numbers.

Notes:

For the NORM instruction, the auxiliary register operations are executed during the fourth phase of the pipeline, the execution phase. For other instructions, the auxiliary register operations take place in the second phase of the pipeline, in the decode phase. Therefore:

- 1) **The auxiliary register values should not be modified by the two instruction words following NORM.** If the auxiliary register used in the NORM instruction is to be affected by either of the next two instruction words, the auxiliary register value will be modified by the other instructions *before* it is modified by the NORM instruction.
- 2) **The value in the auxiliary register pointer (ARP) should not be modified by the two instruction words following NORM.** If either of the next two instruction words specify a change in the ARP value, the ARP value will be changed *before* NORM is executed; the ARP will not be pointing at the correct auxiliary register when NORM is executed.

**Words
Cycles**

1

Cycles for a Single NORM Instruction

ROM	DARAM	SARAM	External
1	1	1	1+p

Cycles for a Repeat (RPT) Execution of a NORM Instruction

ROM	DARAM	SARAM	External
n	n	n	n+p

Example 1

NORM *+

		Before Instruction			After Instruction
ARP		<input type="text" value="2"/>	ARP		<input type="text" value="2"/>
AR2		<input type="text" value="00h"/>	AR2		<input type="text" value="01h"/>
ACC	<input checked="" type="checkbox"/>	<input type="text" value="0FFFFFF001h"/>	ACC	<input checked="" type="checkbox"/>	<input type="text" value="0FFFE002h"/>
	C			C	
	<input checked="" type="checkbox"/>			<input type="checkbox"/>	
	TC			TC	

Example 2

31-Bit Normalization:

```

MAR    *,AR1      ;Use AR1 to store the exponent.
LAR    AR1,#0h   ;Clear out exponent counter.
LOOP   NORM    *+ ;One bit is normalized.
BCND   LOOP,NTC ;If TC = 0, magnitude not found yet.
    
```

Example 3

15-Bit Normalization:

```
MAR    *,AR1      ;Use AR1 to store the exponent.
LAR    AR1,#0Fh   ;Initialize exponent counter.
RPT    #14        ;15-bit normalization specified (yielding
                  ;a 4-bit exponent and 16-bit mantissa).
NORM   *--        ;NORM automatically stops shifting when first
                  ;significant magnitude bit is found,
                  ;performing NOPs for the remainder of the
                  ;repeat loops.
```

The method used in Example 2 normalizes a 32-bit number and yields a 5-bit exponent magnitude. The method used in Example 3 normalizes a 16-bit number and yields a 4-bit magnitude. If the number requires only a small amount of normalization, the Example 2 method may be preferable to the Example 3 method because the loop in Example 2 runs only until normalization is complete. Example 3 always executes all 15 cycles of the repeat loop. Specifically, Example 2 is more efficient if the number requires three or fewer shifts. If the number requires six or more shifts, Example 3 is more efficient.

Syntax	OR dma	Direct addressing
	OR ind [, ARn]	Indirect addressing
	OR #lk [, shift]	Long immediate addressing
	OR #lk, 16	Long immediate with left shift of 16

Operands	dma:	7 LSBs of the data-memory address
	shift:	Left shift value from 0 to 15 (defaults to 0)
	n:	Value from 0 to 7 designating the next auxiliary register
	lk:	16-bit long immediate value
	ind:	Select one of the following seven options: * *+ *− *0+ *0− *BR0+ *BR0−

Opcode**OR dma**

15	14	13	12	11	10	9	8	7	6	5	4	3	2	1	0
0	1	1	0	1	1	0	1	0	dma						

OR ind [, ARn]

15	14	13	12	11	10	9	8	7	6	5	4	3	2	1	0
0	1	1	0	1	1	0	1	1	ARU	N	NAR				

Note: ARU, N, and NAR are defined in Section 6.3, *Indirect Addressing Mode* (page 6-9).

OR #lk [, shift]

15	14	13	12	11	10	9	8	7	6	5	4	3	2	1	0
1	0	1	1	1	1	1	1	1	1	0	0	shift			
lk															

OR #lk [, 16]

15	14	13	12	11	10	9	8	7	6	5	4	3	2	1	0
1	0	1	1	1	1	1	0	1	0	0	0	0	0	1	0
lk															

Execution

Increment PC, then ...

<u>Event(s)</u>	<u>Addressing mode</u>
(ACC(15:0)) OR (data-memory address) → ACC(15:0)	Direct or indirect
(ACC(31:16)) → ACC(31:16)	

(ACC) OR lk × 2 ^{shift} → ACC	Long immediate
--	----------------

(ACC) OR lk × 2 ¹⁶ → ACC	Long immediate with left shift of 16
-------------------------------------	--------------------------------------

Status Bits None
 This instruction is not affected by SXM.

Description An OR operation is performed on the contents of the accumulator and the contents of the addressed data-memory location or a long-immediate value. The long-immediate value may be shifted before the OR operation. The result remains in the accumulator. All bit positions unoccupied by the data operand are zero filled, regardless of the value of the SXM status bit. Thus, the high word of the accumulator is unaffected by this instruction if direct or indirect addressing is used, or if immediate addressing is used with a shift of 0. Zeros are shifted into the least significant bits of the operand if immediate addressing is used with a nonzero shift count.

Words Words Addressing mode
 1 Direct or indirect
 2 Long immediate

Cycles

Cycles for a Single OR Instruction (Using Direct and Indirect Addressing)

Operand	Program			
	ROM	DARAM	SARAM	External
DARAM	1	1	1	1+p
SARAM	1	1	1, 2†	1+p
External	1+d	1+d	1+d	2+d+p

† If the operand and the code are in the same SARAM block

Cycles for a Repeat (RPT) Execution of an OR Instruction (Using Direct and Indirect Addressing)

Operand	Program			
	ROM	DARAM	SARAM	External
DARAM	n	n	n	n+p
SARAM	n	n	n, n+1†	n+p
External	n+nd	n+nd	n+nd	n+1+p+nd

† If the operand and the code are in the same SARAM block

Cycles for a Single OR Instruction (Using Long Immediate Addressing)

ROM	DARAM	SARAM	External
2	2	2	2+2p

Example 1

OR DAT8 ; (DP = 8)

		Before Instruction			After Instruction
Data Memory			Data Memory		
408h		0F000h	408h		0F000h
ACC	<input checked="" type="checkbox"/>	10002h	ACC	<input checked="" type="checkbox"/>	10F02h
	C			C	

Example 2

OR *,AR0

		Before Instruction			After Instruction
ARP		1	ARP		0
AR1		300h	AR1		300h
Data Memory			Data Memory		
300h		1111h	300h		1111h
ACC	<input checked="" type="checkbox"/>	222h	ACC	<input checked="" type="checkbox"/>	1333h
	C			C	

Example 3

OR #08111h,8

		Before Instruction			After Instruction
ACC	<input checked="" type="checkbox"/>	0FF0000h	ACC	<input checked="" type="checkbox"/>	0FF1100h
	C			C	

Cycles**Cycles for a Single OUT Instruction**

Operand	Program			
	ROM	DARAM	SARAM	External
Source: DARAM	$3+i_{dst}$	$3+i_{dst}$	$3+i_{dst}$	$5+i_{dst}+2p_{code}$
Source: SARAM	$3+i_{dst}$	$3+i_{dst}$	$3+i_{dst}$ $4+i_{dst}^\dagger$	$5+i_{dst}+2p_{code}$
Source: External	$3+d_{src}+i_{dst}$	$3+d_{src}+i_{dst}$	$3+d_{src}+i_{dst}$	$6+d_{src}+i_{dst}+2p_{code}$

† If the operand and the code are in the same SARAM block

Cycles for a Repeat (RPT) Execution of an OUT Instruction

Operand	Program			
	ROM	DARAM	SARAM	External
Destination: DARAM	$3n+n_{io_{dst}}$	$3n+n_{io_{dst}}$	$3n+n_{io_{dst}}$	$3n+3+n_{io_{dst}}+2p_{code}$
Destination: SARAM	$3n+n_{io_{dst}}$	$3n+n_{io_{dst}}$	$3n+n_{io_{dst}}$ $3n+1+n_{io_{dst}}^\dagger$	$3n+3+n_{io_{dst}}+2p_{code}$
Destination: External	$5n-2+nd_{src}+n_{io_{dst}}$	$5n-2+nd_{src}+n_{io_{dst}}$	$5n-2+nd_{src}+n_{io_{dst}}$	$5n+1+nd_{src}+n_{io_{dst}}+2p_{code}$

† If the operand and the code are in the same SARAM block

Example 1 `OUT DAT0,100h ;(DP = 4) Write data word stored in
 ;data memory location 200h to
 ;peripheral at I/O port address
 ;100h.`

Example 2 `OUT *,100h ;Write data word referenced by
 ;current auxiliary register to
 ;peripheral at I/O port address
 ;100h.`

Syntax PAC

Operands None

Opcode

15	14	13	12	11	10	9	8	7	6	5	4	3	2	1	0
1	0	1	1	1	1	1	0	0	0	0	0	0	0	1	1

Execution Increment PC, then ...
shifted (PREG) → ACC

Status Bits Affected by
PM

Description The content of PREG, shifted as specified by the PM status bits, is loaded into the accumulator.

Words 1

Cycles

Cycles for a Single PAC Instruction			
ROM	DARAM	SARAM	External
1	1	1	1+p

Cycles for a Repeat (RPT) Execution of a PAC Instruction			
ROM	DARAM	SARAM	External
n	n	n	n+p

Example PAC ; (PM = 0: no shift of product)

		Before Instruction			After Instruction
PREG		144h	PREG		144h
ACC	X	23h	ACC	X	144h
	C			C	

Syntax POP

Operands None

Opcode

15	14	13	12	11	10	9	8	7	6	5	4	3	2	1	0
1	0	1	1	1	1	1	0	0	0	1	1	0	0	1	0

Execution Increment PC, then ...
 (TOS) → ACC(15:0)
 0 → ACC(31:16)
 Pop stack one level

Status Bits None

Description The content of the top of the stack (TOS) is copied to the low accumulator, and then the stack values move up one level. The upper half of the accumulator is set to all zeros.

The hardware stack functions as a last-in, first-out stack with eight locations. Any time a pop occurs, every stack value is copied to the next higher stack location, and the top value is removed from the stack. After a pop, the bottom two stack words will have the same value. Because each stack value is copied, if more than seven stack pops (using the POP, POPD, RETC, or RET instructions) occur before any pushes occur, all levels of the stack will contain the same value. No provision exists to check stack underflow.

Words 1

Cycles

Cycles for a Single POP Instruction

ROM	DARAM	SARAM	External
1	1	1	1+p

Cycles for a Repeat (RPT) Execution of a POP Instruction

ROM	DARAM	SARAM	External
n	n	n	n+p

Example

POP

		Before Instruction		After Instruction	
ACC	<input checked="" type="checkbox"/>	<input type="text" value="82h"/>	ACC	<input checked="" type="checkbox"/>	<input type="text" value="45h"/>
	C			C	
Stack		<input type="text" value="45h"/>	Stack		<input type="text" value="16h"/>
		<input type="text" value="16h"/>			<input type="text" value="7h"/>
		<input type="text" value="7h"/>			<input type="text" value="33h"/>
		<input type="text" value="33h"/>			<input type="text" value="42h"/>
		<input type="text" value="42h"/>			<input type="text" value="56h"/>
		<input type="text" value="56h"/>			<input type="text" value="37h"/>
		<input type="text" value="37h"/>			<input type="text" value="61h"/>
		<input type="text" value="61h"/>			<input type="text" value="61h"/>

Cycles for a Repeat (RPT) Execution of a POPD Instruction

Operand	Program			
	ROM	DARAM	SARAM	External
DARAM	n	n	n	n+p
SARAM	n	n	n, n+2†	n+p
External	2n+nd	2n+nd	2n+nd	2n+2+nd+p

† If the operand and the code are in the same SARAM block

Example 1

```
POPD    DAT10    ; (DP = 8)
```

	Before Instruction		After Instruction
Data Memory		Data Memory	
40Ah	55h	40Ah	92h
Stack	92h	Stack	72h
	72h		8h
	8h		44h
	44h		81h
	81h		75h
	75h		32h
	32h		0AAh
	0AAh		0AAh

Example 2

```
POPD    *, AR1
```

	Before Instruction		After Instruction
ARP	0	ARP	1
AR0	300h	AR0	301h
Data Memory		Data Memory	
300h	55h	300h	92h
Stack	92h	Stack	72h
	72h		8h
	8h		44h
	44h		81h
	81h		75h
	75h		32h
	32h		0AAh
	0AAh		0AAh

Syntax **PSHD** *dma* Direct addressing
 PSHD *ind* [, **AR***n*] Indirect addressing

Operands *dma*: 7 LSBs of the data-memory address
 n: Value from 0 to 7 designating the next auxiliary register
 ind: Select one of the following seven options:
 * *+ *- *0+ *0- *BR0+ *BR0-

Opcode

PSHD *dma*

15	14	13	12	11	10	9	8	7	6	5	4	3	2	1	0
0	1	1	1	0	1	1	0	0	dma						

PSHD *ind* [, **AR***n*]

15	14	13	12	11	10	9	8	7	6	5	4	3	2	1	0
0	1	1	1	0	1	1	0	1	ARU	N	NAR				

Note: ARU, N, and NAR are defined in Section 6.3, *Indirect Addressing Mode* (page 6-9).

Execution Increment PC, then ...
 (data-memory address) → TOS
 Push all stack locations down one level

Status Bits None

Description The value from the data-memory location specified by the instruction is transferred to the top of the stack. In the lower seven locations of the stack, the values are also copied one level down, as explained in the description for the PUSH instruction. The value in the lowest stack location is lost.

Words 1

Cycles

Cycles for a Single PSHD Instruction

Operand	Program			
	ROM	DARAM	SARAM	External
DARAM	1	1	1	1+p
SARAM	1	1	1, 2†	1+p
External	1+d	1+d	1+d	2+d+p

† If the operand and the code are in the same SARAM block

Cycles for a Repeat (RPT) Execution of a PSHD Instruction

Operand	Program			
	ROM	DARAM	SARAM	External
DARAM	n	n	n	n+p
SARAM	n	n	n, n+1†	n+p
External	n+nd	n+nd	n+nd	n+1+nd+p

† If the operand and the code are in the same SARAM block

Example 1

PSHD 127 ; (DP = 3: addresses 0180-01FFh)

	Before Instruction		After Instruction	
Data Memory			Data Memory	
1FFh	<input type="text" value="65h"/>		1FFh	<input type="text" value="65h"/>
Stack	<input type="text" value="2h"/>		Stack	<input type="text" value="65h"/>
	<input type="text" value="33h"/>			<input type="text" value="2h"/>
	<input type="text" value="78h"/>			<input type="text" value="33h"/>
	<input type="text" value="99h"/>			<input type="text" value="78h"/>
	<input type="text" value="42h"/>			<input type="text" value="99h"/>
	<input type="text" value="50h"/>			<input type="text" value="42h"/>
	<input type="text" value="0h"/>			<input type="text" value="50h"/>
	<input type="text" value="0h"/>			<input type="text" value="0h"/>

Example 2

PSHD *, AR1

	Before Instruction		After Instruction	
ARP	<input type="text" value="0"/>		ARP	<input type="text" value="1"/>
AR0	<input type="text" value="1FFh"/>		AR0	<input type="text" value="1FFh"/>
Data Memory			Data Memory	
1FFh	<input type="text" value="12h"/>		1FFh	<input type="text" value="12h"/>
Stack	<input type="text" value="2h"/>		Stack	<input type="text" value="12h"/>
	<input type="text" value="33h"/>			<input type="text" value="2h"/>
	<input type="text" value="78h"/>			<input type="text" value="33h"/>
	<input type="text" value="99h"/>			<input type="text" value="78h"/>
	<input type="text" value="42h"/>			<input type="text" value="99h"/>
	<input type="text" value="50h"/>			<input type="text" value="42h"/>
	<input type="text" value="0h"/>			<input type="text" value="50h"/>
	<input type="text" value="0h"/>			<input type="text" value="0h"/>

Syntax **PUSH**

Operands None

Opcode 15 14 13 12 11 10 9 8 7 6 5 4 3 2 1 0
1 0 1 1 1 1 1 0 0 0 1 1 1 1 0 0

Execution Increment PC, then...
 Push all stack locations down one level
 ACC(15:0) → TOS

Status Bits None

Description The stack values move down one level. Then, the content of the lower half of the accumulator is copied onto the top of the hardware stack.

The hardware stack operates as a last-in, first-out stack with eight locations. If more than eight pushes (due to a CALA, CALL, CC, PSHD, PUSH, TRAP, INTR, or NMI instruction) occur before a pop, the first data values written are lost with each succeeding push.

Words 1

Cycles

Cycles for a Single PUSH Instruction

ROM	DARAM	SARAM	External
1	1	1	1+p

Cycles for a Repeat (RPT) Execution of a PUSH Instruction

ROM	DARAM	SARAM	External
n	n	n	n+p

Example PUSH

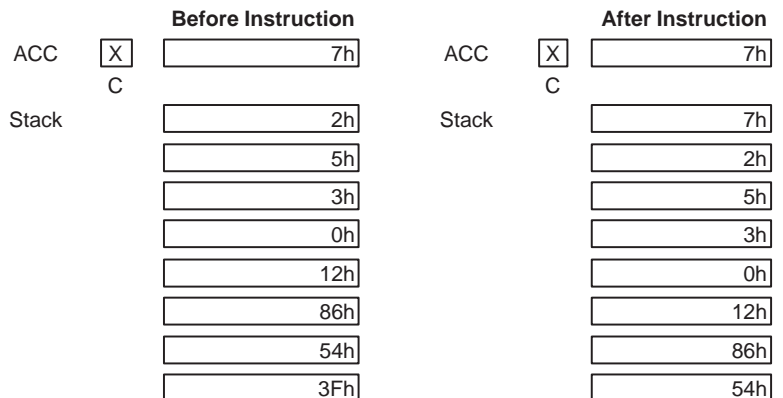

Syntax **RET**

Operands None

Opcode

15	14	13	12	11	10	9	8	7	6	5	4	3	2	1	0
1	1	1	0	1	1	1	1	0	0	0	0	0	0	0	0

Execution (TOS) → PC
 Pop stack one level.

Status Bits None

Description The contents of the top stack register are copied into the program counter. The remaining stack values are then copied up one level. RET concludes subroutines and interrupt service routines to return program control to the calling or interrupted program sequence.

Words 1

Cycles

Cycles for a Single RET Instruction

ROM	DARAM	SARAM	External
4	4	4	4+3p

Note: When this instruction reaches the execute phase of the pipeline, two additional instruction words have entered the pipeline. When the PC discontinuity is taken, these two instruction words are discarded.

Example

RET

		Before Instruction		After Instruction
PC		96h	PC	37h
Stack		37h	Stack	45h
		45h		75h
		75h		21h
		21h		3Fh
		3Fh		45h
		45h		6Eh
		6Eh		6Eh
		6Eh		6Eh

Syntax **RETC** *cond 1* [, *cond 2*] [...]

Operands	<u>cond</u>	<u>Condition</u>
	EQ	ACC = 0
	NEQ	ACC ≠ 0
	LT	ACC < 0
	LEQ	ACC ≤ 0
	GT	ACC > 0
	GEQ	ACC ≥ 0
	NC	C = 0
	C	C = 1
	NOV	OV = 0
	OV	OV = 1
	BIO	$\overline{\text{BIO}}$ low
	NTC	TC = 0
	TC	TC = 1
	UNC	Unconditionally

‡

Opcode	15	14	13	12	11	10	9	8	7	6	5	4	3	2	1	0
	1	1	1	0	1	1	TP		ZLVC			ZLVC				

Note: The TP and ZLVC fields are defined on pages 7-3 and 7-4.

Execution If *cond 1* AND *cond 2* AND ...
 (TOS) → PC
 Pop stack one level
 Else, continue

Status Bits None

Description If the specified condition or conditions are met, a standard return is executed (see the description for the RET instruction). Note that not all combinations of conditions are meaningful. For example, testing for LT and GT is contradictory. In addition, testing $\overline{\text{BIO}}$ is mutually exclusive to testing TC.

Words 1

Cycles

Cycles for a Single RETC Instruction

Condition	ROM	DARAM	SARAM	External
True	4	4	4	4+4p
False	2	2	2	2+2p

Note: The processor performs speculative fetching by reading two additional instruction words. If the PC discontinuity is taken, these two instruction words are discarded.

Example RETC GEQ,NOV ;A return is executed if the
 ;accumulator content is positive
 ;or zero and if the OV (overflow)
 ;-bit is zero.

Syntax ROL

Operands None

Opcode

	15	14	13	12	11	10	9	8	7	6	5	4	3	2	1	0
	1	0	1	1	1	1	1	0	0	0	0	0	1	1	0	0

Execution Increment PC, then ...
 C → ACC(0)
 (ACC(31)) → C
 (ACC(30:0)) → ACC(31:1)

Status Bits Affects
 C

This instruction is not affected by SXM.

Description The ROL instruction rotates the accumulator left one bit. The value of the carry bit is shifted into the LSB, then the MSB is shifted into the carry bit.

Words 1

Cycles

Cycles for a Single ROL Instruction			
ROM	DARAM	SARAM	External
1	1	1	1+p

Cycles for a Repeat (RPT) Execution of an ROL Instruction			
ROM	DARAM	SARAM	External
n	n	n	n+p

Example ROL

		Before Instruction			After Instruction
ACC	0	B0001234h		ACC	1
	C				C
					60002468h

Syntax ROR

Operands None

Opcode

15	14	13	12	11	10	9	8	7	6	5	4	3	2	1	0
1	0	1	1	1	1	1	0	0	0	0	0	1	1	0	1

Execution Increment PC, then ...
 C → ACC(31)
 (ACC(0)) → C
 (ACC(31:1)) → ACC(30:0)

Status Bits Affects
 C

This instruction is not affected by SXM.

Description The ROR instruction rotates the accumulator right one bit. The value of the carry bit is shifted into the MSB of the accumulator, then the LSB of the accumulator is shifted into the carry bit.

Words 1

Cycles	Cycles for a Single ROR Instruction			
	ROM	DARAM	SARAM	External
	1	1	1	1+p

Cycles for a Repeat (RPT) Execution of an ROR Instruction			
ROM	DARAM	SARAM	External
n	n	n	n+p

Example ROR

		Before Instruction			After Instruction
ACC	0	B0001235h	ACC	1	5800091Ah
	C			C	

Syntax	RPT dma RPT ind[, ARn] RPT #k	Direct addressing Indirect addressing Short immediate
---------------	--	---

Operands	dma: 7 LSBs of the data-memory address n: Value from 0 to 7 designating the next auxiliary register k: 8-bit short immediate value ind: Select one of the following seven options: * *+ *- *0+ *0- *BR0+ *BR0-
-----------------	---

Opcode

RPT dma

15	14	13	12	11	10	9	8	7	6	5	4	3	2	1	0
0	0	0	0	1	0	1	1	0	dma						

RPT ind[, ARn]

15	14	13	12	11	10	9	8	7	6	5	4	3	2	1	0
0	0	0	0	1	0	1	1	1	ARU		N	NAR			

Note: ARU, N, and NAR are defined in Section 6.3, *Indirect Addressing Mode* (page 6-9).

RPT #k

15	14	13	12	11	10	9	8	7	6	5	4	3	2	1	0
1	0	1	1	1	0	1	1	k							

Execution	Increment PC, then ... <u>Event</u> (data-memory address) → RPTC k → RPTC	<u>Addressing mode</u> Direct or indirect Short immediate
------------------	--	---

Status Bits None

Description

The repeat counter (RPTC) is loaded with the content of the addressed data-memory location if direct or indirect addressing is used; it is loaded with an 8-bit immediate value if short immediate addressing is used. The instruction following the RPT is repeated *n* times, where *n* is the initial value of the RPTC plus 1. Since the RPTC cannot be saved during a context switch, repeat loops are regarded as multicycle instructions and are not interruptible. The RPTC is cleared to 0 on a device reset.

RPT is especially useful for block moves, multiply/accumulates, and normalization. The repeat instruction itself is not repeatable.

Words 1

Cycles**Cycles for a Single RPT Instruction (Using Direct and Indirect Addressing)**

Operand	Program			
	ROM	DARAM	SARAM	External
DARAM	1	1	1	1+p
SARAM	1	1	1, 2†	1+p
External	1+d	1+d	1+d	2+d+p

† If the operand and the code are in the same SARAM block

Cycles for a Single RPT Instruction (Using Short Immediate Addressing)

ROM	DARAM	SARAM	External
1	1	1	1+p

Example 1

```
RPT  DAT127      ;(DP = 31: addresses 0F80h-0FFFh)
                ;Repeat next instruction 13 times.
```

		Before Instruction	After Instruction	
Data Memory	0FFFh	<input type="text" value="0Ch"/>	Data Memory	<input type="text" value="0Ch"/>
	RPTC	<input type="text" value="0h"/>	RPTC	<input type="text" value="0Ch"/>

Example 2

```
RPT  *,AR1      ;Repeat next instruction 4096 times.
```

		Before Instruction	After Instruction	
ARP		<input type="text" value="0"/>	ARP	<input type="text" value="1"/>
AR0		<input type="text" value="300h"/>	AR0	<input type="text" value="300h"/>
Data Memory	300h	<input type="text" value="0FFFh"/>	Data Memory	<input type="text" value="0FFFh"/>
	RPTC	<input type="text" value="0h"/>	RPTC	<input type="text" value="0FFFh"/>

Example 3

```
RPT  #1         ;Repeat next instruction two times.
```

		Before Instruction	After Instruction	
RPTC		<input type="text" value="0h"/>	RPTC	<input type="text" value="1h"/>

Cycles for a Repeat (RPT) Execution of an SACH Instruction

Operand	Program			
	ROM	DARAM	SARAM	External
DARAM	n	n	n	n+p
SARAM	n	n	n, n+2 [†]	n+p
External	2n+nd	2n+nd	2n+nd	2n+2+nd+p

[†] If the operand and the code are in the same SARAM block

Example 1

SACH DAT10,1 ;(DP = 4: addresses 0200h-027Fh,
;left shift of 1)

Before Instruction		After Instruction			
ACC	<input checked="" type="checkbox"/> <input type="checkbox"/> C	<input type="text" value="4208001h"/>	ACC	<input checked="" type="checkbox"/> <input type="checkbox"/> C	<input type="text" value="4208001h"/>
Data Memory		<input type="text" value="0h"/>	Data Memory		<input type="text" value="0841h"/>
20Ah			20Ah		

Example 2

SACH *+,0,AR2 ;(No shift)

Before Instruction		After Instruction	
ARP	<input type="text" value="1"/>	ARP	<input type="text" value="2"/>
AR1	<input type="text" value="300h"/>	AR1	<input type="text" value="301h"/>
ACC	<input checked="" type="checkbox"/> <input type="checkbox"/> C	ACC	<input checked="" type="checkbox"/> <input type="checkbox"/> C
	<input type="text" value="4208001h"/>		<input type="text" value="4208001h"/>
Data Memory		Data Memory	
300h	<input type="text" value="0h"/>	300h	<input type="text" value="0420h"/>

Syntax **SACL** *dma* [, *shift2*] Direct addressing
SACL *ind* [, *shift2* [, **AR***n*]] Indirect addressing

Operands

dma: 7 LSBs of the data-memory address
shift2: Left shift value from 0 to 7 (defaults to 0)
n: Value from 0 to 7 designating the next auxiliary register
ind: Select one of the following seven options:
 * *+ *- *0+ *0- *BR0+ *BR0-

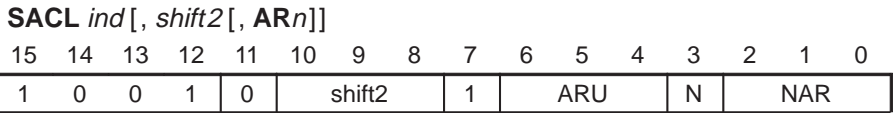
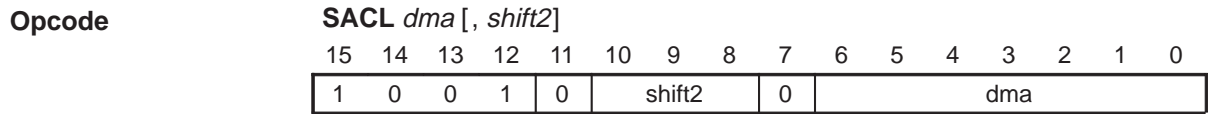

Note: ARU, N, and NAR are defined in Section 6.3, *Indirect Addressing Mode* (page 6-9).

Execution Increment PC, then ...
 16 LSBs of ((ACC) × 2^{shift2}) → data-memory address

Status Bits This instruction is not affected by SXM.

Description The SACL instruction copies the entire accumulator into the output shifter, where it left shifts the entire 32-bit number from 0 to 7 bits. It then copies the lower 16 bits of the shifted value into data memory. During the shift, the low-order bits are filled with zeros, and the high-order bits are lost. The accumulator itself remains unaffected.

Words 1

Cycles **Cycles for a Single SACL Instruction**

Operand	Program			
	ROM	DARAM	SARAM	External
DARAM	1	1	1	1+p
SARAM	1	1	1, 2†	1+p
External	2+d	2+d	2+d	4+d+p

† If the operand and the code are in the same SARAM block.

Cycles for a Repeat (RPT) Execution of an SACL Instruction

Operand	Program			
	ROM	DARAM	SARAM	External
DARAM	n	n	n	n+p
SARAM	n	n	n, n+2 [†]	n+p
External	2n+nd	2n+nd	2n+nd	2n+2+nd+p

[†] If the operand and the code are in the same SARAM block.

Example 1

```
SACL    DAT11,1    ;(DP = 4: addresses 0200h-027Fh,
                ;left shift of 1)
```

		Before Instruction		After Instruction	
ACC	<input checked="" type="checkbox"/> C	<input type="text" value="7C63 8421"/>	ACC	<input checked="" type="checkbox"/> C	<input type="text" value="7C63 8421h"/>
Data Memory	20Bh	<input type="text" value="05h"/>	Data Memory	20Bh	<input type="text" value="0842h"/>

Example 2

```
SACL    *,0,AR7    ;(No shift)
```

		Before Instruction		After Instruction	
ARP		<input type="text" value="6"/>	ARP		<input type="text" value="7"/>
AR6		<input type="text" value="300h"/>	AR6		<input type="text" value="300h"/>
ACC	<input checked="" type="checkbox"/> C	<input type="text" value="00FF 8421h"/>	ACC	<input checked="" type="checkbox"/> C	<input type="text" value="00FF 8421h"/>
Data Memory	300h	<input type="text" value="05h"/>	Data Memory	300h	<input type="text" value="8421h"/>

Cycles for a Repeat (RPT) Execution of an SAR Instruction

Operand	Program			
	ROM	DARAM	SARAM	External
DARAM	n	n	n	n+p
SARAM	n	n	n, n+2 [†]	n+p
External	2n+nd	2n+nd	2n+nd	2n+2+nd+p

[†] If the operand and the code are in the same SARAM block

Example 1

SAR AR0, DAT30 ; (DP = 6: addresses 0300h-037Fh)

		Before Instruction			After Instruction
	AR0	37h		AR0	37h
	Data Memory 31Eh	18h		Data Memory 31Eh	37h

Example 2

SAR AR0, *+

		Before Instruction			After Instruction
	ARP	0		ARP	0
	AR0	401h		AR0	402h
	Data Memory 401h	0h		Data Memory 401h	401h

Syntax **SBRK #k** Short immediate addressing

Operands k: 8-bit positive short immediate value

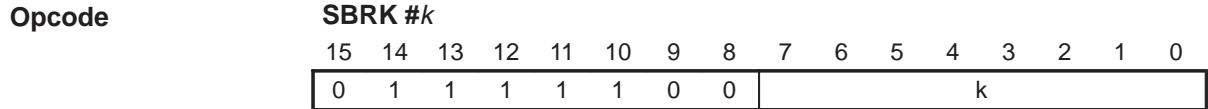

Execution Increment PC, then ...
 (current AR) – k → current AR

Note that k is an 8-bit positive constant.

Status Bits None

Description The 8-bit immediate value is subtracted, right justified, from the content of the current auxiliary register (the one pointed to by the ARP) and the result replaces the contents of the auxiliary register. The subtraction takes place in the auxiliary register arithmetic unit (ARAU), with the immediate value treated as an 8-bit positive integer. All arithmetic operations on the auxiliary registers are unsigned.

Words 1

Cycles **Cycles for a Single SBRK Instruction**

ROM	DARAM	SARAM	External
1	1	1	1+p

Example SBRK #0FFh

		Before Instruction		After Instruction
	ARP	7	ARP	7
	AR7	0h	AR7	FF01h

Syntax**SETC** control bit**Operands**

control bit: Select one of the following control bits:

C	Carry bit of status register ST1
CNF	RAM configuration control bit of status register ST1
INTM	Interrupt mode bit of status register ST0
OVM	Overflow mode bit of status register ST0
SXM	Sign-extension mode bit of status register ST1
TC	Test/control flag bit of status register ST1
XF	XF pin status bit of status register ST1

Opcode**SETC C**

15	14	13	12	11	10	9	8	7	6	5	4	3	2	1	0
1	0	1	1	1	1	1	0	0	1	0	0	1	1	1	1

SETC CNF

15	14	13	12	11	10	9	8	7	6	5	4	3	2	1	0
1	0	1	1	1	1	1	0	0	1	0	0	0	1	0	1

SETC INTM

15	14	13	12	11	10	9	8	7	6	5	4	3	2	1	0
1	0	1	1	1	1	1	0	0	1	0	0	0	0	0	1

SETC OVM

15	14	13	12	11	10	9	8	7	6	5	4	3	2	1	0
1	0	1	1	1	1	1	0	0	1	0	0	0	0	1	1

SETC SXM

15	14	13	12	11	10	9	8	7	6	5	4	3	2	1	0
1	0	1	1	1	1	1	0	0	1	0	0	0	1	1	1

SETC TC

15	14	13	12	11	10	9	8	7	6	5	4	3	2	1	0
1	0	1	1	1	1	1	0	0	1	0	0	1	0	1	1

SETC XF

15	14	13	12	11	10	9	8	7	6	5	4	3	2	1	0
1	0	1	1	1	1	1	0	0	1	0	0	1	1	0	1

Execution

Increment PC, then ...
1 → control bit

Status Bits

None

Description

The specified control bit is set to 1. Note that LST may also be used to load ST0 and ST1. See Section 3.5, *Status and Control Registers*, on page 3-15 for more information on each control bit.

Words 1

Cycles

Cycles for a Single SETC Instruction

ROM	DARAM	SARAM	External
1	1	1	1+p

Cycles for a Repeat (RPT) Execution of an SETC Instruction

ROM	DARAM	SARAM	External
n	n	n	n+p

Example

SETC TC ;TC is bit 11 of ST1



Syntax SFL**Operands** None

Opcode

15	14	13	12	11	10	9	8	7	6	5	4	3	2	1	0
1	0	1	1	1	1	1	0	0	0	0	0	1	0	0	1

Execution Increment PC, then ...
 (ACC(31)) → C
 (ACC(30:0)) → ACC(31:1)
 0 → ACC(0)

Status Bits Affects
 C

This instruction is not affected by SXM.

Description The SFL instruction shifts the entire accumulator left one bit. The least significant bit is filled with a 0, and the most significant bit is shifted into the carry bit (C). SFL, unlike SFR, is unaffected by SXM.

Words 1

Cycles

Cycles for a Single SFL Instruction

ROM	DARAM	SARAM	External
1	1	1	1+p

Cycles for a Repeat (RPT) Execution of an SFL Instruction

ROM	DARAM	SARAM	External
n	n	n	n+p

Example SFL

		Before Instruction			After Instruction
ACC	<input checked="" type="checkbox"/>	<input type="text" value="B0001234h"/>	ACC	<input type="checkbox"/>	<input type="text" value="60002468h"/>
	C			C	

Syntax **SFR**

Operands None

Opcode

15	14	13	12	11	10	9	8	7	6	5	4	3	2	1	0
1	0	1	1	1	1	1	0	0	0	0	0	1	0	1	0

Execution

Increment PC, then ...
 If SXM = 0
 Then 0 → ACC(31).
 If SXM = 1
 Then (ACC(31)) → ACC(31)

(ACC(31:1)) → ACC(30:0)
 (ACC(0)) → C

Status Bits

<u>Affected by</u>	<u>Affects</u>
SXM	C

Description

The SFR instruction shifts the accumulator right one bit.

- If SXM = 1, the instruction produces an arithmetic right shift. The sign bit (MSB) is unchanged and is also copied into bit 30. Bit 0 is shifted into the carry bit (C).
- If SXM = 0, the instruction produces a logic right shift. All of the accumulator bits are shifted right by one bit. The least significant bit is shifted into the carry bit, and the most significant bit is filled with a 0.

Words 1

Cycles

Cycles for a Single SFR Instruction			
ROM	DARAM	SARAM	External
1	1	1	1+p

Cycles for a Repeat (RPT) Execution of an SFR Instruction			
ROM	DARAM	SARAM	External
n	n	n	n+p

Example 1

SFR ;(SXM = 0: no sign extension)

		Before Instruction			After Instruction
ACC	<input checked="" type="checkbox"/>	<input type="text" value="B0001234h"/>	ACC	<input type="checkbox"/>	<input type="text" value="5800091Ah"/>
	C			C	

Example 2

SFR ;(SXM = 1: sign extend)

		Before Instruction			After Instruction
ACC	<input checked="" type="checkbox"/>	<input type="text" value="B0001234h"/>	ACC	<input type="checkbox"/>	<input type="text" value="D800091Ah"/>
	C			C	

Syntax SPAC

Operands None

Opcode

	15	14	13	12	11	10	9	8	7	6	5	4	3	2	1	0
	1	0	1	1	1	1	1	0	0	0	0	0	0	1	0	1

Execution Increment PC, then ...
(ACC) – shifted (PREG) → ACC

Status Bits

<u>Affected by</u>	<u>Affects</u>
PM and OVM	C and OV

This instruction is not affected by SXM.

Description The content of PREG, shifted as defined by the PM status bits, is subtracted from the content of the accumulator. The result is stored in the accumulator. SPAC is not affected by SXM, and the PREG value is always sign extended.

The function of the SPAC instruction is a subtask of the LTS, MPYS, and SQRS instructions.

Words 1

Cycles

Cycles for a Single SPAC Instruction			
ROM	DARAM	SARAM	External
1	1	1	1+p

Cycles for a Repeat (RPT) Execution of an SPAC Instruction			
ROM	DARAM	SARAM	External
n	n	n	n+p

Example SPAC ; (PM = 0)

		Before Instruction			After Instruction
PREG		10000000h		PREG	10000000h
ACC	X	70000000h		ACC	1
	C				C
					60000000h

Syntax	SPH dma SPH ind [, ARn]	Direct addressing Indirect addressing
Operands	dma: 7 LSBs of the data-memory address n: Value from 0 to 7 designating the next auxiliary register ind: Select one of the following seven options: * *+ *− *0+ *0− *BR0+ *BR0−	

Opcode	SPH dma
	15 14 13 12 11 10 9 8 7 6 5 4 3 2 1 0
	1 0 0 0 1 1 0 1 0 dma

	SPH ind [, ARn]
	15 14 13 12 11 10 9 8 7 6 5 4 3 2 1 0
	1 0 0 0 1 1 0 1 1 ARU N NAR

Note: ARU, N, and NAR are defined in Section 6.3, *Indirect Addressing Mode* (page 6-9).

Execution	Increment PC, then ... 16 MSBs of shifted (PREG) → data-memory address
------------------	---

Status Bits	<u>Affected by</u> PM
--------------------	--------------------------

Description	The 16 high-order bits of the PREG, shifted as specified by the PM bits, are stored in data memory. First, the 32-bit PREG value is copied into the product shifter, where it is shifted as specified by the PM bits. If the right-shift-by-6 mode is selected, the high-order bits are sign extended and the low-order bits are lost. If a left shift is selected, the high-order bits are lost and the low-order bits are zero filled. If PM = 00, no shift occurs. Then the 16 MSBs of the shifted value are stored in data memory. Neither the PREG value nor the accumulator value is modified by this instruction.
--------------------	--

Words	1
--------------	---

Cycles

Cycles for a Single SPH Instruction

Operand	Program			
	ROM	DARAM	SARAM	External
DARAM	1	1	1	1+p
SARAM	1	1	1, 2†	1+p
External	2+d	2+d	2+d	4+d+p

† If the operand and the code are in the same SARAM block

Cycles for a Repeat (RPT) Execution of an SPH Instruction

Operand	Program			
	ROM	DARAM	SARAM	External
DARAM	n	n	n	n+p
SARAM	n	n	n, n+2†	n+p
External	2n+nd	2n+nd	2n+nd	2n+2+nd+p

† If the operand and the code are in the same SARAM block

Example 1

SPH DAT3 ;(DP = 4: addresses 0200h-027Fh,
 ;PM = 0: no shift)

	Before Instruction		After Instruction
PREG	FE079844h	PREG	FE079844h
Data Memory 203h	4567h	Data Memory 203h	FE07h

Example 2

SPH *,AR7 ;(PM = 2: left shift of four)

	Before Instruction		After Instruction
ARP	6	ARP	7
AR6	203h	AR6	203h
PREG	FE079844h	PREG	FE079844h
Data Memory 203h	4567h	Data Memory 203h	E079h

Syntax	SPL dma SPL ind [, ARn]	Direct addressing Indirect addressing
Operands	dma: 7 LSBs of the data-memory address n: Value from 0 to 7 designating the next auxiliary register ind: Select one of the following seven options: * *+ *− *0+ *0− *BR0+ *BR0−	

Opcode	SPL dma
	15 14 13 12 11 10 9 8 7 6 5 4 3 2 1 0
	1 0 0 0 1 1 0 0 0 dma

	SPL ind [, ARn]
	15 14 13 12 11 10 9 8 7 6 5 4 3 2 1 0
	1 0 0 0 1 1 0 0 1 ARU N NAR

Note: ARU, N, and NAR are defined in Section 6.3, *Indirect Addressing Mode* (page 6-9).

Execution	Increment PC, then ... 16 LSBs of shifted (PREG) → data-memory address
------------------	---

Status Bits	<u>Affected by</u> PM
--------------------	--------------------------

Description	The 16 low-order bits of the PREG, shifted as specified by the PM bits, are stored in data memory. First, the 32-bit PREG value is copied into the product shifter, where it is shifted as specified by the PM bits. If the right-shift-by-6 mode is selected, the high-order bits are sign extended and the low-order bits are lost. If a left shift is selected, the high-order bits are lost and the low-order bits are zero filled. If PM = 00, no shift occurs. Then the 16 LSBs of the shifted value are stored in data memory. Neither the PREG value nor the accumulator value is modified by this instruction.
--------------------	---

Words	1
--------------	---

Cycles

Cycles for a Single SPL Instruction

Operand	Program			
	ROM	DARAM	SARAM	External
DARAM	1	1	1	1+p
SARAM	1	1	1, 2†	1+p
External	2+d	2+d	2+d	4+d+p

† If the operand and the code are in the same SARAM block

Cycles for a Repeat (RPT) Execution of an SPL Instruction

Operand	Program			
	ROM	DARAM	SARAM	External
DARAM	n	n	n	n+p
SARAM	n	n	n, n+2†	n+p
External	2n+nd	2n+nd	2n+nd	2n+2+nd+p

† If the operand and the code are in the same SARAM block

Example 1

SPL	DAT5	;(DP = 4: addresses 0200h-027Fh, ;PM = 2: left shift of four)	
		Before Instruction	After Instruction
	PREG	0FE079844h	PREG 0FE079844h
	Data Memory 205h	4567h	Data Memory 205h 08440h

Example 2

SPL	*,AR3	;(PM = 0: no shift)	
		Before Instruction	After Instruction
	ARP	2	ARP 3
	AR2	205h	AR2 205h
	PREG	0FE079844h	PREG 0FE079844h
	Data Memory 205h	4567h	Data Memory 205h 09844h

Syntax	SPLK #lk, dma	Direct addressing
	SPLK #lk, ind [, ARn]	Indirect addressing
Operands	dma:	7 LSBs of the data-memory address
	n:	Value from 0 to 7 designating the next auxiliary register
	lk:	16-bit long immediate value
	ind:	Select one of the following seven options: * *+ *− *0+ *0− *BR0+ *BR0−

Opcode	SPLK #lk, dma
	15 14 13 12 11 10 9 8 7 6 5 4 3 2 1 0
	1 0 1 0 1 1 1 0 0 dma
	lk
	SPLK #lk, ind [, ARn]
	15 14 13 12 11 10 9 8 7 6 5 4 3 2 1 0
	1 0 1 0 1 1 1 0 1 ARU N NAR
	lk

Note: ARU, N, and NAR are defined in Section 6.3, *Indirect Addressing Mode* (page 6-9).

Execution	Increment PC, then ... lk → data-memory address
Status Bits	None
Description	The SPLK instruction allows a full 16-bit pattern to be written into any data memory location.
Words	2
Cycles	

Cycles for a Single SPLK Instruction

Operand	Program			
	ROM	DARAM	SARAM	External
DARAM	2	2	2	2+2p
SARAM	2	2	2, 3†	2+2p
External	3+d	3+d	3+d	5+d+2p

† If the operand and the code are in the same SARAM block

Example 1

SPLK #7FFFh, DAT3 ; (DP = 6)

	Before Instruction		After Instruction	
Data Memory 303h		FE07h	Data Memory 303h	7FFFh

Example 2

SPLK #1111h, *, AR4

	Before Instruction		After Instruction
ARP	<input type="text" value="0"/>	ARP	<input type="text" value="4"/>
AR0	<input type="text" value="300h"/>	AR0	<input type="text" value="301h"/>
Data Memory 300h	<input type="text" value="07h"/>	Data Memory 300h	<input type="text" value="1111h"/>

Syntax	SPM constant																																
Operands	constant: Value from 0 to 3 that determines the product shift mode																																
Opcode	<table border="1"> <tr> <td>15</td><td>14</td><td>13</td><td>12</td><td>11</td><td>10</td><td>9</td><td>8</td><td>7</td><td>6</td><td>5</td><td>4</td><td>3</td><td>2</td><td>1</td><td>0</td> </tr> <tr> <td>1</td><td>0</td><td>1</td><td>1</td><td>1</td><td>1</td><td>1</td><td>1</td><td>0</td><td>0</td><td>0</td><td>0</td><td>0</td><td>0</td><td>0</td><td>constant</td> </tr> </table>	15	14	13	12	11	10	9	8	7	6	5	4	3	2	1	0	1	0	1	1	1	1	1	1	0	0	0	0	0	0	0	constant
15	14	13	12	11	10	9	8	7	6	5	4	3	2	1	0																		
1	0	1	1	1	1	1	1	0	0	0	0	0	0	0	constant																		
Execution	Increment PC, then ... constant → product shift mode (PM) bits																																
Status Bits	<u>Affects</u> PM This instruction is not affected by SXM.																																
Description	The two LSBs of the instruction word are copied into the product shift mode (PM) bits of status register ST1 (bits 1 and 0 of ST1). The PM bits control the mode of the shifter at the output of the PREG. This shifter can shift the PREG output either one or four bits to the left or six bits to the right. The possible PM bit combinations and their meanings are shown in Table 7–8. When an instruction accesses the PREG value, the value first passes through the shifter, where it is shifted by the specified amount.																																

Table 7–8. Product Shift Modes

PM Field	Specified Product Shift
00	No shift of PREG output
01	PREG output to be left shifted 1 place
10	PREG output to be left shifted 4 places
11	PREG output to be right shifted 6 places and sign extended

The left shifts allow the product to be justified for fractional arithmetic. The right-shift-by-six mode allows up to 128 multiply accumulate processes without the possibility of overflow occurring. PM may also be loaded by an LST #1 instruction.

Words	1												
Cycles	<table border="1"> <thead> <tr> <th colspan="4">Cycles for a Single SPM Instruction</th> </tr> <tr> <th>ROM</th> <th>DARAM</th> <th>SARAM</th> <th>External</th> </tr> </thead> <tbody> <tr> <td>1</td> <td>1</td> <td>1</td> <td>1+p</td> </tr> </tbody> </table>	Cycles for a Single SPM Instruction				ROM	DARAM	SARAM	External	1	1	1	1+p
Cycles for a Single SPM Instruction													
ROM	DARAM	SARAM	External										
1	1	1	1+p										
Example	<pre>SPM 3 ;Product register shift mode 3 (PM = 11) ;is selected causing all subsequent ;transfers from the product register (PREG) ;to be shifted to the right six places.</pre>												

Syntax **SQRA** *dma* Direct addressing
SQRA *ind* [, **AR***n*] Indirect addressing

Operands *dma*: 7 LSBs of the data-memory address
n: Value from 0 to 7 designating the next auxiliary register
ind: Select one of the following seven options:
 * *+ *- *0+ *0- *BR0+ *BR0-

Opcode **SQRA** *dma*

15	14	13	12	11	10	9	8	7	6	5	4	3	2	1	0
0	1	0	1	0	0	1	0	0	dma						

SQRA *ind* [, **AR***n*]

15	14	13	12	11	10	9	8	7	6	5	4	3	2	1	0
0	1	0	1	0	0	1	0	1	ARU	N	NAR				

Note: ARU, N, and NAR are defined in Section 6.3, *Indirect Addressing Mode* (page 6-9).

Execution Increment PC, then ...
 (ACC) + shifted (PREG) → ACC
 (data-memory address) → TREG
 (TREG) × (data-memory address) → PREG

Status Bits Affected by Affects
 OVM and PM OV and C

Description The content of the PREG, shifted as defined by the PM status bits, is added to the accumulator. Then the addressed data-memory value is loaded into the TREG, squared, and stored in the PREG.

Words 1

Cycles **Cycles for a Single SQRA Instruction**

Operand	Program			
	ROM	DARAM	SARAM	External
DARAM	1	1	1	1+p
SARAM	1	1	1, 2†	1+p
External	1+d	1+d	1+d	2+d+p

† If the operand and the code are in the same SARAM block

Cycles for a Repeat (RPT) Execution of an SQRA Instruction

Operand	Program			
	ROM	DARAM	SARAM	External
DARAM	n	n	n	n+p
SARAM	n	n	n, n+1†	n+p
External	n+nd	n+nd	n+nd	n+1+p+nd

† If the operand and the code are in the same SARAM block

Example 1

SQRA DAT30 ; (DP = 6: addresses 0300h–037Fh,
; PM = 0: no shift of product)

		Before Instruction		After Instruction	
Data Memory				Data Memory	
	31Eh	0Fh		31Eh	0Fh
	TREG	3h		TREG	0Fh
	PREG	12Ch		PREG	0E1h
	ACC	1F4h		ACC	320h
	C	X		C	0

Example 2

SQRA *, AR4 ; (PM = 0)

		Before Instruction		After Instruction	
ARP		3		ARP	4
AR3		31Eh		AR3	31Eh
Data Memory				Data Memory	
	31Eh	0Fh		31Eh	0Fh
	TREG	3h		TREG	0Fh
	PREG	12Ch		PREG	0E1h
	ACC	1F4h		ACC	320h
	C	X		C	0

Syntax **SQRS** *dma* Direct addressing
SQRS *ind* [, **AR***n*] Indirect addressing

Operands *dma*: 7 LSBs of the data-memory address
n: Value from 0 to 7 designating the next auxiliary register
ind: Select one of the following seven options:
 * *+ *- *0+ *0- *BR0+ *BR0-

Opcode **SQRS** *dma*

15	14	13	12	11	10	9	8	7	6	5	4	3	2	1	0
0	1	0	1	0	0	1	1	0	dma						

SQRS *ind* [, **AR***n*]

15	14	13	12	11	10	9	8	7	6	5	4	3	2	1	0
0	1	0	1	0	0	1	1	1	ARU		N	NAR			

Note: ARU, N, and NAR are defined in Section 6.3, *Indirect Addressing Mode* (page 6-9).

Execution Increment PC, then ...
 (ACC) – shifted (PREG) → ACC
 (data-memory address) → TREG
 (TREG) × (data-memory address) → PREG

Status Bits Affected by Affects
 OVM and PM OV and C

Description The content of the PREG, shifted as defined by the PM status bits, is subtracted from the accumulator. Then the addressed data-memory value is loaded into the TREG, squared, and stored in the PREG.

Words 1

Cycles **Cycles for a Single SQRS Instruction**

Operand	Program			
	ROM	DARAM	SARAM	External
DARAM	1	1	1	1+p
SARAM	1	1	1, 2†	1+p
External	1+d	1+d	1+d	2+d+p

† If the operand and the code are in the same SARAM block

Cycles for a Repeat (RPT) Execution of an SQRS Instruction

Operand	Program			
	ROM	DARAM	SARAM	External
DARAM	n	n	n	n+p
SARAM	n	n	n, n+1†	n+p
External	n+nd	n+nd	n+nd	n+1+p+nd

† If the operand and the code are in the same SARAM block

Example 1

SQRS DAT9 ; (DP = 6: addresses 0300h–037Fh,
 ; PM = 0: no shift of product)

		Before Instruction		After Instruction	
Data Memory				Data Memory	
309h		08h		309h	08h
TREG		1124h		TREG	08h
PREG		190h		PREG	40h
ACC	X	1450h		ACC	1
	C				C

Example 2

SQRS *, AR5 ; (PM = 0)

		Before Instruction		After Instruction	
ARP		3		ARP	5
AR3		309h		AR3	309h
Data Memory				Data Memory	
309h		08h		309h	08h
TREG		1124h		TREG	08h
PREG		190h		PREG	40h
ACC	X	1450h		ACC	1
	C				C

Status registers ST0 and ST1 are defined in Section 3.5, *Status Registers ST0 and ST1*, on page 3-15.

Words

1

Cycles

Cycles for a Single SST Instruction

Operand	Program			
	ROM	DARAM	SARAM	External
DARAM	1	1	1	1+p
SARAM	1	1	1, 2 [†]	1+p
External	2+d	2+d	2+d	4+d+p

[†] If the operand and the code are in the same SARAM block

Cycles for a Repeat (RPT) Execution of an SST Instruction

Operand	Program			
	ROM	DARAM	SARAM	External
DARAM	n	n	n	n+p
SARAM	n	n	n, n+2 [†]	n+p
External	2n+nd	2n+nd	2n+nd	2n+2+nd+p

[†] If the operand and the code are in the same SARAM block

Example 1

SST #0,96 (Direct addressing: data page 0
;accessed automatically)

	Before Instruction		After Instruction
ST0	0A408h	ST0	0A408h
Data Memory 60h	0Ah	Data Memory 60h	0A408h

Example 2

SST #1,*,AR7 (Indirect addressing)

	Before Instruction		After Instruction
ARP	0	ARP	7
AR0	300h	AR0	300h
ST1	2580h	ST1	2580h
Data Memory 300h	0h	Data Memory 300h	2580h

Syntax	SUB <i>dma</i> [, <i>shift</i>]	Direct addressing
	SUB <i>dma</i> ,16	Direct with left shift of 16
	SUB <i>ind</i> [, <i>shift</i> [, AR <i>n</i>]]	Indirect addressing
	SUB <i>ind</i> ,16[, AR <i>n</i>]	Indirect with left shift of 16
	SUB # <i>k</i>	Short immediate
	SUB # <i>lk</i> [, <i>shift</i>]	Long immediate

Operands	dma :	7 LSBs of the data-memory address
	shift :	Left shift value from 0 to 15 (defaults to 0)
	n :	Value from 0 to 7 designating the next auxiliary register
	k :	8-bit short immediate value
	lk :	16-bit long immediate value
	ind :	Select one of the following seven options: * *+ *− *0+ *0− *BR0+ *BR0−

Opcode

SUB *dma* [,*shift*]

15	14	13	12	11	10	9	8	7	6	5	4	3	2	1	0
0	0	1	1	shift				0	dma						

SUB *dma*, 16

15	14	13	12	11	10	9	8	7	6	5	4	3	2	1	0
0	1	1	0	0	1	0	1	0	dma						

SUB *ind* [, *shift* [, **AR***n*]]

15	14	13	12	11	10	9	8	7	6	5	4	3	2	1	0
0	0	1	1	shift				1	ARU	N	NAR				

Note: ARU, N, and NAR are defined in Section 6.3, *Indirect Addressing Mode* (page 6-9).

SUB *ind*,16 [, **AR***n*]

15	14	13	12	11	10	9	8	7	6	5	4	3	2	1	0
0	1	1	0	0	1	0	1	1	ARU	N	NAR				

Note: ARU, N, and NAR are defined in Section 6.3, *Indirect Addressing Mode* (page 6-9).

SUB #*k*

15	14	13	12	11	10	9	8	7	6	5	4	3	2	1	0
1	0	1	1	1	0	1	0	k							

SUB #*lk* [, *shift*]

15	14	13	12	11	10	9	8	7	6	5	4	3	2	1	0
1	0	1	1	1	1	1	1	1	0	1	0	shift			
lk															

Execution	Increment PC, then ...		
	<u>Event</u>		<u>Addressing mode</u>
	$(ACC) - ((\text{data-memory address}) \times 2^{\text{shift}}) \rightarrow ACC$		Direct or indirect
	$(ACC) - ((\text{data-memory address}) \times 2^{16}) \rightarrow ACC$		Direct or indirect (shift of 16)
	$(ACC) - k \rightarrow ACC$		Short immediate
	$(ACC) - lk \times 2^{\text{shift}} \rightarrow ACC$		Long immediate
Status Bits	<u>Affected by</u>	<u>Affects</u>	<u>Addressing mode</u>
	OVM and SXM	OV and C	Direct or indirect
	OVM	OV and C	Short immediate
	OVM and SXM	OV and C	Long immediate
Description	<p>In direct, indirect, and long immediate addressing, the content of the addressed data-memory location or a 16-bit constant are left shifted and subtracted from the accumulator. During shifting, low-order bits are zero filled. High-order bits are sign extended if SXM = 1 and zero filled if SXM = 0. The result is then stored in the accumulator.</p> <p>If short immediate addressing is used, an 8-bit positive constant is subtracted from the accumulator. In this case, no shift value may be specified, the subtraction is unaffected by SXM, and the instruction is not repeatable.</p> <p>Normally, the carry bit is cleared (C = 0) if the result of the subtraction generates a borrow and is set (C = 1) if it does not generate a borrow. However, if a 16-bit shift is specified with the subtraction, the instruction will clear the carry bit if a borrow is generated but will not affect the carry bit otherwise.</p>		
	Words	<u>Words</u>	<u>Addressing mode</u>
		1	Direct, indirect or short immediate
	2	Long immediate	

Cycles

Cycles for a Single SUB Instruction (Using Direct and Indirect Addressing)

Operand	Program			
	ROM	DARAM	SARAM	External
DARAM	1	1	1	1+p
SARAM	1	1	1, 2†	1+p
External	1+d	1+d	1+d	2+d+p

† If the operand and the code are in the same SARAM block.

Cycles for a Repeat (RPT) Execution of an SUB Instruction (Using Direct and Indirect Addressing)

Operand	Program			
	ROM	DARAM	SARAM	External
DARAM	n	n	n	n+p
SARAM	n	n	n, n+1†	n+p
External	n+nd	n+nd	n+nd	n+1+p+nd

† If the operand and the code are in the same SARAM block.

Cycles for a Single SUB Instruction (Using Short Immediate Addressing)

ROM	DARAM	SARAM	External
1	1	1	1+p

Cycles for a Single SUB Instruction (Using Long Immediate Addressing)

ROM	DARAM	SARAM	External
2	2	2	2+2p

Example 1

```
SUB    DAT80    ;(DP = 8: addresses 0400h-047Fh,
              ;SXM=0: sign-extension suppressed)
```

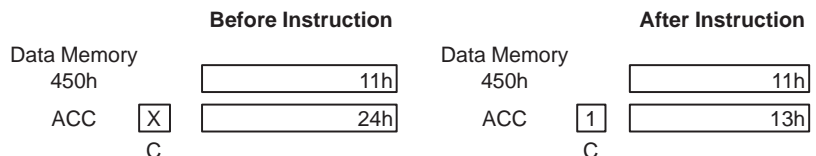

Example 2

```
SUB    *-,1,AR0 ;(Left shift by 1, SXM = 0)
```

		Before Instruction			After Instruction
ARP		7	ARP		0
AR7		301h	AR7		300h
Data Memory			Data Memory		
301h		04h	301h		04h
ACC	<input checked="" type="checkbox"/> C	09h	ACC	<input type="checkbox"/> C	01h

Example 3

SUB #8h ;(SXM = 1: sign-extension mode)

		Before Instruction			After Instruction
ACC	<input checked="" type="checkbox"/> C	07h	ACC	<input type="checkbox"/> C	FFFFFFFh

Example 4

SUB #0FFFh,4 ;(Left shift by four, SXM = 0)

		Before Instruction			After Instruction
ACC	<input checked="" type="checkbox"/> C	0FFFh	ACC	<input type="checkbox"/> C	0Fh

Cycles for a Repeat (RPT) Execution of an SUBB Instruction

Operand	Program			
	ROM	DARAM	SARAM	External
DARAM	n	n	n	n+p
SARAM	n	n	n, n+1†	n+p
External	n+nd	n+nd	n+nd	n+1+p+nd

† If the operand and the code are in the same SARAM block

Example 1

SUBB DAT5 ; (DP = 8: addresses 0400h–047Fh)

		Before Instruction			After Instruction
Data Memory	405h	06h	Data Memory	405h	06h
ACC	0	06h	ACC	0	0FFFFFFFh
	C			C	

Example 2

SUBB *

		Before Instruction			After Instruction
ARP		6	ARP		6
AR6		301h	AR6		301h
Data Memory	301h	02h	Data Memory	301h	02h
ACC	1	04h	ACC	1	02h
	C			C	

In the first example, C is originally zeroed, presumably from the result of a previous subtract instruction that performed a borrow. The effective operation performed was $6 - 6 - (0-) = -1$, generating another borrow (resetting carry) in the process. In the second example, no borrow was previously generated ($C = 1$), and the result from the subtract instruction does not generate a borrow.

SUBC affects OV but is not affected by OVM; therefore, the accumulator does not saturate upon positive or negative overflows when executing this instruction. The carry bit is affected in the normal manner during this instruction: the carry bit is cleared (C = 0) if the result of the subtraction generates a borrow and is set (C = 1) if it does not generate a borrow.

Words

1

Cycles

Cycles for a Single SUBC Instruction

Operand	Program			
	ROM	DARAM	SARAM	External
DARAM	1	1	1	1+p
SARAM	1	1	1, 2†	1+p
External	1+d	1+d	1+d	2+d+p

† If the operand and the code are in the same SARAM block

Cycles for a Repeat (RPT) Execution of an SUBC Instruction

Operand	Program			
	ROM	DARAM	SARAM	External
DARAM	n	n	n	n+p
SARAM	n	n	n, n+1†	n+p
External	n+nd	n+nd	n+nd	n+1+p+nd

† If the operand and the code are in the same SARAM block

Example 1

SUBC DAT2 ; (DP = 6)

Before Instruction				After Instruction			
Data Memory	302h		01h	Data Memory	302h		01h
ACC	X		04h	ACC	0		08h
		C				C	

Example 2

RPT #15
SUBC *

Before Instruction				After Instruction			
ARP			3	ARP			3
AR3			1000h	AR3			1000h
Data Memory	1000h		07h	Data Memory	1000h		07h
ACC	X		41h	ACC	1		20009h
		C				C	

Cycles for a Repeat (RPT) Execution of an SUBS Instruction

Operand	Program			
	ROM	DARAM	SARAM	External
DARAM	n	n	n	n+p
SARAM	n	n	n, n+1†	n+p
External	n+nd	n+nd	n+nd	n+1+p+nd

† If the operand and the code are in the same SARAM block

Example 1

SUBS DAT2 ; (DP = 16, SXM = 1)

Before Instruction				After Instruction			
Data Memory	802h		0F003h	Data Memory	802h		0F003h
ACC	X		0F105h	ACC	1		102h
	C				C		

Example 2

SUBS * ; (SXM = 1)

Before Instruction				After Instruction			
ARP			0	ARP			0
AR0			310h	AR0			310h
Data Memory	310h		0F003h	Data Memory	310h		0F003h
ACC	X		0FFFF105h	ACC	1		0FFF0102h
	C				C		

Cycles

Cycles for a Single SUBT Instruction

Operand	Program			
	ROM	DARAM	SARAM	External
DARAM	1	1	1	1+p
SARAM	1	1	1, 2†	1+p
External	1+d	1+d	1+d	2+d+p

† If the operand and the code are in the same SARAM block.

Cycles for a Repeat (RPT) Execution of an SUBT Instruction

Operand	Program			
	ROM	DARAM	SARAM	External
DARAM	n	n	n	n+p
SARAM	n	n	n, n+1†	n+p
External	n+nd	n+nd	n+nd	n+1+p+nd

† If the operand and the code are in the same SARAM block.

Example 1

SUBT DAT127 ; (DP = 5: addresses 0280h–02FFh)

		Before Instruction		After Instruction	
Data Memory	2FFh	<input type="text" value="06h"/>	Data Memory	2FFh	<input type="text" value="06h"/>
TREG		<input type="text" value="08h"/>	TREG		<input type="text" value="08h"/>
ACC	<input checked="" type="checkbox"/>	<input type="text" value="0FDA5h"/>	ACC	<input type="checkbox"/>	<input type="text" value="0F7A5h"/>
	C			C	

Example 2

SUBT *

		Before Instruction		After Instruction	
ARP		<input type="text" value="1"/>	ARP		<input type="text" value="1"/>
AR1		<input type="text" value="800h"/>	AR1		<input type="text" value="800h"/>
Data Memory	800h	<input type="text" value="01h"/>	Data Memory	800h	<input type="text" value="01h"/>
TREG		<input type="text" value="08h"/>	TREG		<input type="text" value="08h"/>
ACC	<input checked="" type="checkbox"/>	<input type="text" value="0h"/>	ACC	<input type="checkbox"/>	<input type="text" value="FFFFFF00h"/>
	C			C	

Cycles**Cycles for a Single TBLR Instruction**

Operand	Program			
	ROM	DARAM	SARAM	External
Source: DARAM/ROM Destination: DARAM	3	3	3	$3+p_{code}$
Source: SARAM Destination: DARAM	3	3	3	$3+p_{code}$
Source: External Destination: DARAM	$3+p_{src}$	$3+p_{src}$	$3+p_{src}$	$3+p_{src}+p_{code}$
Source: DARAM/ROM Destination: SARAM	3	3	3 4 [†]	$3+p_{code}$
Source: SARAM Destination: SARAM	3	3	3 4 [†]	$3+p_{code}$
Source: External Destination: SARAM	$3+p_{src}$	$3+p_{src}$	$3+p_{src}$ $4+p_{src}$ [†]	$3+p_{src}+p_{code}$
Source: DARAM/ROM Destination: External	$4+d_{dst}$	$4+d_{dst}$	$4+d_{dst}$	$6+d_{dst}+p_{code}$
Source: SARAM Destination: External	$4+d_{dst}$	$4+d_{dst}$	$4+d_{dst}$	$6+d_{dst}+p_{code}$
Source: External Destination: External	$4+p_{src}+d_{dst}$	$4+p_{src}+d_{dst}$	$4+p_{src}+d_{dst}$	$6+p_{src}+d_{dst}+p_{code}$

[†] If the destination operand and the code are in the same SARAM block

Cycles for a Repeat (RPT) Execution of a TBLR Instruction

Operand	Program			
	ROM	DARAM	SARAM	External
Source: DARAM/ROM Destination: DARAM	n+2	n+2	n+2	$n+2+p_{code}$
Source: SARAM Destination: DARAM	n+2	n+2	n+2	$n+2+p_{code}$
Source: External Destination: DARAM	$n+2+np_{src}$	$n+2+np_{src}$	$n+2+np_{src}$	$n+2+np_{src}+p_{code}$

[†] If the destination operand and the code are in the same SARAM block

[‡] If both the source and the destination operands are in the same SARAM block

[§] If both operands and the code are in the same SARAM block

Cycles for a Repeat (RPT) Execution of a TBLR Instruction (Continued)

Operand	Program			
	ROM	DARAM	SARAM	External
Source: DARAM/ROM Destination: SARAM	n+2	n+2	n+2 n+4†	n+2+p _{code}
Source: SARAM Destination: SARAM	n+2 2n‡	n+2 2n‡	n+2 2n‡ 2n+2§	n+2+p _{code} 2n‡
Source: External Destination: SARAM	n+2+np _{src}	n+2+np _{src}	n+2+np _{src} n+4+np _{src} †	n+2+np _{src} +p _{code}
Source: DARAM/ROM Destination: External	2n+2+nd _{dst}	2n+2+nd _{dst}	2n+2+nd _{dst}	2n+4+nd _{dst} +p _{code}
Source: SARAM Destination: External	2n+2+nd _{dst}	2n+2+nd _{dst}	2n+2+nd _{dst}	2n+4+nd _{dst} +p _{code}
Source: External Destination: External	4n+np _{src} +nd _{dst}	4n+np _{src} +nd _{dst}	4n+np _{src} +nd _{dst}	4n+2+np _{src} +nd _{dst} + p _{code}

† If the destination operand and the code are in the same SARAM block

‡ If both the source and the destination operands are in the same SARAM block

§ If both operands and the code are in the same SARAM block

Example 1

TBLR DAT6 ; (DP = 4: addresses 0200h-027Fh)

	Before Instruction		After Instruction
ACC	23h	ACC	23h
Program Memory 23h	306h	Program Memory 23h	306h
Data Memory 206h	75h	Data Memory 206h	306h

Example 2

TBLR *, AR7

	Before Instruction		After Instruction
ARP	0	ARP	7
AR0	300h	AR0	300h
ACC	24h	ACC	24h
Program Memory 24h	307h	Program Memory 24h	307h
Data Memory 300h	75h	Data Memory 300h	307h

Cycles

Cycles for a Single TBLW Instruction

Operand	Program			
	ROM	DARAM	SARAM	External
Source: DARAM/ROM Destination: DARAM	3	3	3	3+p _{code}
Source: SARAM Destination: DARAM	3	3	3	3+p _{code}
Source: External Destination: DARAM	3+d _{src}	3+d _{src}	3+d _{src}	3+d _{src} +p _{code}
Source: DARAM/ROM Destination: SARAM	3	3	3 4†	3+p _{code}
Source: SARAM Destination: SARAM	3	3	3 4†	3+p _{code}
Source: External Destination: SARAM	3+d _{src}	3+d _{src}	3+d _{src} 4+d _{src} †	3+d _{src} +p _{code}
Source: DARAM/ROM Destination: External	4+p _{dst}	4+p _{dst}	4+p _{dst}	5+p _{dst} +p _{code}
Source: SARAM Destination: External	4+p _{dst}	4+p _{dst}	4+p _{dst}	5+p _{dst} +p _{code}
Source: External Destination: External	4+d _{src} +p _{dst}	4+d _{src} +p _{dst}	4+d _{src} +p _{dst}	5+d _{src} +p _{dst} +p _{code}

† If the destination operand and the code are in the same SARAM block

Cycles for a Repeat (RPT) Execution of a TBLW Instruction

Operand	Program			
	ROM	DARAM	SARAM	External
Source: DARAM/ROM Destination: DARAM	n+2	n+2	n+2	n+2+p _{code}
Source: SARAM Destination: DARAM	n+2	n+2	n+2	n+2+p _{code}
Source: External Destination: DARAM	n+2+nd _{src}	n+2+nd _{src}	n+2+nd _{src}	n+2+nd _{src} +p _{code}

† If the destination operand and the code are in the same SARAM block

‡ If both the source and the destination operands are in the same SARAM block

§ If both operands and the code are in the same SARAM block

Cycles for a Repeat (RPT) Execution of a TBLW Instruction (Continued)

Operand	Program			
	ROM	DARAM	SARAM	External
Source: DARAM/ROM Destination: SARAM	n+2	n+2	n+2 n+3†	n+2+p _{code}
Source: SARAM Destination: SARAM	n+2 2n‡	n+2 2n‡	n+2 2n‡ 2n+1§	n+2+p _{code} 2n‡
Source: External Destination: SARAM	n+2+nd _{src}	n+2+nd _{src}	n+2+nd _{src} n+3+nd _{src} †	n+2+nd _{src} +p _{code}
Source: DARAM/ROM Destination: External	2n+2+np _{dst}	2n+2+np _{dst}	2n+2+np _{dst}	2n+3+np _{dst} +p _{code}
Source: SARAM Destination: External	2n+2+np _{dst}	2n+2+np _{dst}	2n+2+np _{dst}	2n+3+np _{dst} +p _{code}
Source: External Destination: External	4n+nd _{src} +np _{dst}	4n+nd _{src} +np _{dst}	4n+nd _{src} +np _{dst}	4n+1+nd _{src} +np _{dst} + p _{code}

† If the destination operand and the code are in the same SARAM block

‡ If both the source and the destination operands are in the same SARAM block

§ If both operands and the code are in the same SARAM block

Example 1

TBLW	DAT5	; (DP = 32: addresses 1000h–107Fh)			
		Before Instruction		After Instruction	
	ACC	<input type="text" value="257h"/>	ACC	<input type="text" value="257h"/>	
	Data Memory 1005h	<input type="text" value="4339h"/>	Data Memory 1005h	<input type="text" value="4339h"/>	
	Program Memory 257h	<input type="text" value="306h"/>	Program Memory 257h	<input type="text" value="4399h"/>	

Example 2

TBLW	*				
		Before Instruction		After Instruction	
	ARP	<input type="text" value="6"/>	ARP	<input type="text" value="6"/>	
	AR6	<input type="text" value="1006h"/>	AR6	<input type="text" value="1006h"/>	
	ACC	<input type="text" value="258h"/>	ACC	<input type="text" value="258h"/>	
	Data Memory 1006h	<input type="text" value="4340h"/>	Data Memory 1006h	<input type="text" value="4340h"/>	
	Program Memory 258h	<input type="text" value="307h"/>	Program Memory 258h	<input type="text" value="4340h"/>	

Syntax **TRAP**

Operands None

Opcode

15	14	13	12	11	10	9	8	7	6	5	4	3	2	1	0
1	0	1	1	1	1	1	0	0	1	0	1	0	0	0	1

Execution (PC) + 1 → stack
 22h → PC

Status Bits Not affected by INTM; does not affect INTM.

Description The TRAP instruction is a software interrupt that transfers program control to program-memory location 22h and pushes the program counter (PC) plus 1 onto the hardware stack. The instruction at location 22h may contain a branch instruction to transfer control to the TRAP routine. Putting (PC + 1) onto the stack enables a return instruction to pop the return address (which points to the instruction after TRAP) from the stack. The TRAP instruction is not maskable.

Words 1

Cycles

Cycles for a Single TRAP Instruction			
ROM	DARAM	SARAM	External
4	4	4	4+3p†

† The processor performs speculative fetching by reading two additional instruction words. If the PC discontinuity is taken, these two instruction words are discarded.

Example TRAP ;PC + 1 is pushed onto the stack, and then
 ;control is passed to program memory location
 ;22h.

Syntax	XOR dma	Direct addressing
	XOR ind [, ARn]	Indirect addressing
	XOR #lk, [, shift]	Long immediate addressing
	XOR #lk,16	Long immediate with left shift of 16

Operands	dma:	7 LSBs of the data-memory address
	shift:	Left shift value from 0 to 15 (defaults to 0)
	n:	Value from 0 to 7 designating the next auxiliary register
	lk:	16-bit long immediate value
	ind:	Select one of the following seven options: * *+ *− *0+ *0− *BR0+ *BR0−

Opcode**XOR dma**

15	14	13	12	11	10	9	8	7	6	5	4	3	2	1	0
0	1	1	0	1	1	0	0	0	dma						

XOR ind [, ARn]

15	14	13	12	11	10	9	8	7	6	5	4	3	2	1	0
0	1	1	0	1	1	0	0	1	ARU		N	NAR			

Note: ARU, N, and NAR are defined in Section 6.3, *Indirect Addressing Mode* (page 6-9).

XOR #lk [, shift]

15	14	13	12	11	10	9	8	7	6	5	4	3	2	1	0
1	0	1	1	1	1	1	1	1	1	0	1	shift			
lk															

XOR #lk, 16

15	14	13	12	11	10	9	8	7	6	5	4	3	2	1	0
1	0	1	1	1	1	1	0	1	0	0	0	0	0	1	1
lk															

Execution

Increment PC, then ...

Event(s) Addressing mode
 (ACC(15:0)) XOR (data-memory address) → ACC(15:0) Direct or indirect
 (ACC(31:16)) → ACC(31:16)

(ACC(31:0)) XOR lk × 2^{shift} → ACC(31:0) Long immediate

(ACC(31:0)) XOR lk × 2¹⁶ → ACC(31:0) Long immediate with left shift of 16

Status Bits None

Description With direct or indirect addressing, the low half of the accumulator value is exclusive ORed with the content of the addressed data memory location, and the result replaces the low half of the accumulator value; the upper half of the accumulator value is unaffected. With immediate addressing, the long immediate constant is shifted and zero filled on both ends and exclusive ORed with the entire content of the accumulator. The carry bit (C) is unaffected by XOR.

Words Words Addressing mode
 1 Direct or indirect
 2 Long immediate

Cycles **Cycles for a Single XOR Instruction (Using Direct and Indirect Addressing)**

Operand	Program			
	ROM	DARAM	SARAM	External
DARAM	1	1	1	1+p
SARAM	1	1	1, 2†	1+p
External	1+d	1+d	1+d	2+d+p

† If the operand and the code are in the same SARAM block

Cycles for a Repeat (RPT) Execution of an XOR Instruction (Using Direct and Indirect Addressing)

Operand	Program			
	ROM	DARAM	SARAM	External
DARAM	n	n	n	n+p
SARAM	n	n	n, n+1†	n+p
External	n+nd	n+nd	n+nd	n+1+p+nd

† If the operand and the code are in the same SARAM block

Cycles for a Single XOR Instruction (Using Long Immediate Addressing)

ROM	DARAM	SARAM	External
2	2	2	2+2p

Example 1 XOR DAT127 ; (DP = 511: addresses FF80h-FFFFh)

		Before Instruction		After Instruction	
	Data Memory		0F0F0h		0F0F0h
	0FFFFh				
	ACC	X	12345678h	X	1234A688h
		C		C	

Example 2 XOR *, AR0

		Before Instruction		After Instruction	
	ARP		7		0
	AR7		300h		301h
	Data Memory				
	300h		0FFFFh		0FFFFh
	ACC	X	1234F0F0h	X	12340F0Fh
		C		C	

Example 3 XOR #0F0F0h, 4 ; (First shift data value left by
; four)

		Before Instruction		After Instruction	
	ACC	X	11111010h	X	111E1F10h
		C		C	

Cycles for a Repeat (RPT) Execution of a ZALR Instruction

Operand	Program			
	ROM	DARAM	SARAM	External
DARAM	n	n	n	n+p
SARAM	n	n	n, n+1†	n+p
External	n+nd	n+nd	n+nd	n+1+p+nd

† If the operand and the code are in the same SARAM block

Example 1

ZALR DAT3 ; (DP = 32: addresses 1000h-107Fh)

		Before Instruction		After Instruction	
Data Memory	1003h	<input type="text" value="3F01h"/>	Data Memory	1003h	<input type="text" value="3F01h"/>
ACC	<input checked="" type="checkbox"/>	<input type="text" value="77FFFFh"/>	ACC	<input checked="" type="checkbox"/>	<input type="text" value="3F018000h"/>
	C			C	

Example 2

ZALR *- , AR4

		Before Instruction		After Instruction	
ARP		<input type="text" value="7"/>	ARP		<input type="text" value="4"/>
AR7		<input type="text" value="0FF00h"/>	AR7		<input type="text" value="0FEFFh"/>
Data Memory	0FF00h	<input type="text" value="0E0E0h"/>	Data Memory	0FF00h	<input type="text" value="0E0E0h"/>
ACC	<input checked="" type="checkbox"/>	<input type="text" value="107777h"/>	ACC	<input checked="" type="checkbox"/>	<input type="text" value="0E0E08000h"/>
	C			C	

On-Chip Peripherals

This chapter discusses on-chip peripherals connected to the 'C2xx CPU and their control registers. The on-chip peripherals are controlled through memory-mapped registers. The operations of the timer and the serial ports are synchronized to the processor through interrupts and interrupt polling. The 'C2xx on-chip peripherals are:

- Clock generator
- Timer
- Software-programmable wait-state generator
- General-purpose I/O pins
- Synchronous serial port (SSP)
- Asynchronous serial port (ASP), or UART

The serial ports are discussed in Chapter 9 and Chapter 10.

For examples of program code for the on-chip peripherals, see Appendix C, *Program Examples*.

Topic	Page
8.1 Control of On-Chip Peripherals	8-2
8.2 Clock Generator	8-4
8.3 CLKOUT1-Pin Control (CLK) Register	8-7
8.4 Timer	8-8
8.5 Wait-State Generator	8-14
8.6 General-Purpose I/O Pins	8-17

8.1 Control of On-Chip Peripherals

The on-chip peripherals are controlled by accessing control registers that are mapped to on-chip I/O space. Data is also transferred to and from the peripherals through these registers. Setting and clearing bits in these registers can enable, disable, initialize, and dynamically reconfigure the on-chip peripherals.

On a device reset, the CPU sends an internal $\overline{\text{SRESET}}$ signal to the peripheral circuits. Table 8–1 lists the peripheral registers and summarizes what happens when the values in these registers are reset. For a description of all the effects of a device reset, see Section 5.7, *Reset Operation*, on page 5-33.

Table 8–1. Peripheral Register Locations and Reset Conditions

Register Name	I/O Address		Reset Value	Effects at Reset
	'C209	Other 'C2xx		
CLK	–	FFE8h	0000h	<i>CLKOUT1-pin control (CLK) register.</i> The CLKOUT1 signal is available at the CLKOUT1 pin.
SDTR	–	FFF0h	xxxxh	<i>Synchronous data transmit and receive register.</i> The value in this register is undefined after reset.
SSPCR	–	FFF1h	0030h	<i>Synchronous serial port control register.</i> The port emulation mode is set to immediate stop. Error and status flags are reset. Receive interrupts are set to occur when the receive buffer is not empty. Transmit interrupts are set to occur when the transmit buffer can accept one or more words. External clock and frame synchronization sources are selected. Continuous mode is selected. Digital loopback mode is disabled. The receiver and transmitter are enabled.
ADTR	–	FFF4h	xxxxh	<i>Asynchronous data transmit and receive register.</i> The value in this register is undefined after reset.
ASPCR	–	FFF5h	0000h	<i>Asynchronous serial port control register.</i> The port emulation mode is set to immediate stop. Receive, transmit, and delta interrupts are disabled. One stop bit is selected. Auto-baud alignment is disabled. The TX pin is forced high between transmissions. I/O pins IO0, IO1, IO2, and IO3 are configured as inputs. The port is disabled.

Table 8–1. Peripheral Register Locations and Reset Conditions (Continued)

Register Name	I/O Address		Reset Value	Effects at Reset
	'C209	Other 'C2xx		
IOSR	–	FFF6h	18xxh	<i>I/O status register.</i> Auto-baud alignment is disabled. Error and status flags are reset. The lower eight bits are dependent on the values on pins IO0, IO1, IO2, and IO3 at reset.
BRD	–	FFF7h	0001h	<i>Baud rate divisor register.</i> A baud rate of (CLKOUT1 rate)/16 is selected.
TCR	FFFCh	FFF8h	0000h	<i>Timer control register.</i> The divide-down value is 0, and the timer is started.
PRD	FFFDh	FFF9h	FFFFh	<i>Timer period register.</i> The next value to be loaded into the timer counter register (TIM) is at its highest value.
TIM	FFFEh	FFFAh	FFFFh	<i>Timer counter register.</i> The timer count is at its highest value.
WSGR	FFFFh	FFFCh	0FFFh	<i>Wait-state generator control register.</i> The maximum number of wait states are selected for off-chip program, data, and I/O spaces.

8.2 Clock Generator

The high pulse of the master clock output signal (CLKOUT1) signifies the logic phase of the device (the phase when values are changed), while the low pulse signifies the latch phase (the phase when values are latched). CLKOUT1 determines much of the device's operational speed. For example:

- The timer clock rate is a fraction of the rate of CLKOUT1.
- Each instruction cycle is equal to one CLKOUT1 period.
- Each wait state generated by the READY signal or by the on-chip wait-state generator is equal to one CLKOUT1 period.

You control the rate of CLKOUT1 with the on-chip clock generator. The clock generator creates an internal CPU clock signal CLKOUT1 whose rate is a fraction or multiple of a source clock signal CLKIN. This generator consists of two independent components, an oscillator and a phase lock loop (PLL) circuit. The internal oscillator, in conjunction with an external resonator circuit, allows you to generate CLKIN internally and create a CLKOUT1 signal that oscillates at half the frequency of CLKIN. The PLL makes the rate of CLKOUT1 a multiple of the rate of CLKIN and locks the phase of CLKOUT1 to that of CLKIN.

CLKIN can be generated by the internal oscillator or by an external oscillator:

- Internal oscillator.** The clock source is generated internally by connecting a crystal resonator circuit across the CLKIN/X2 and X1 pins. The crystal should be in either fundamental or overtone operation and parallel resonant, with an effective series resistance of 30 ohms and a power dissipation of 1 mW. It should also be specified at a load capacitance of 20 pF. Figure 8–1 shows the setup for a fundamental frequency crystal. Overtone crystals require an additional tuned-LC circuit.

When the internal oscillator is used, the frequency of CLKOUT1 is half the oscillating frequency of the crystal. For example, a 40-MHz crystal will provide a CLKOUT1 rate of 20 MHz, providing 20 MIPS of processing power.

Figure 8–1. Using the Internal Oscillator

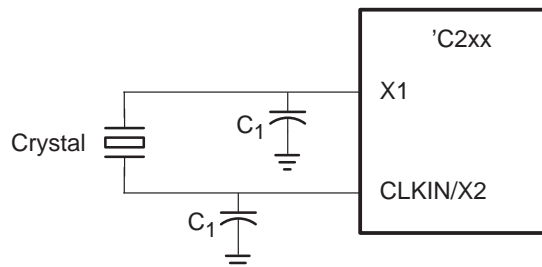

- ❑ **External Oscillator.** CLKIN is the output of an external oscillator, which is connected to the CLKIN/X2 pin. The X1 pin must be left unconnected. See Figure 8–2.

Figure 8–2. Using an External Oscillator

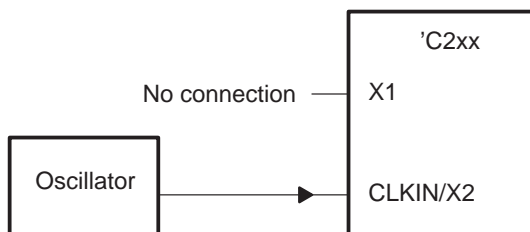

Regardless of the method used to generate CLKOUT1, CLKOUT1 is also available at the CLKOUT1 pin, unless the pin is turned off by the CLK register (see Section 8.3).

You can lower the power requirements for the 'C2xx by slowing down or stopping the input clock.

Note:

When restarting the system, activate \overline{RS} before starting or stopping the clock, and hold it active until the clock stabilizes. This brings the device back to a known state.

8.2.1 Clock Generator Options

The 'C2xx provides four clock modes: divide-by-2 ($\div 2$), multiply-by-1 ($\times 1$), multiply-by-2 ($\times 2$), and multiply-by-4 ($\times 4$). The $\div 2$ mode operates the CPU at half the input clock rate. Each of the other modes operates the CPU at a multiple of the input clock rate and phase locks the output clock with the the input clock. You set the mode by changing the levels on the DIV1 and DIV2 pins. For each mode, Table 8–2 shows the generated CPU clock rate and the state of DIV2, DIV1, the internal oscillator, and the internal phase lock loop (PLL).

Notes:

- 1) Change DIV1 and DIV2 only while the reset signal (\overline{RS}) is active.
- 2) The PLL requires approximately 2500 cycles to lock the output clock signal to the input clock signal. When setting the $\times 1$, $\times 2$, or $\times 4$ mode, keep the reset (\overline{RS}) signal active until at least three cycles after the PLL has stabilized.

Table 8–2. 'C2xx Input Clock Modes

Clock Mode	CLKOUT1 Rate	DIV2	DIV1	External CLKIN Source?	Internal Oscillator	Internal PLL
÷ 2	CLKOUT1 = CLKIN ÷ 2	0	0	No	Enabled	Disabled
				Yes	Disabled	Disabled
× 1	CLKOUT1 = CLKIN × 1	0	1	Required	Disabled	Enabled
× 2	CLKOUT1 = CLKIN × 2	1	0	Required	Disabled	Enabled
× 4	CLKOUT1 = CLKIN × 4	1	1	Required	Disabled	Enabled

Remember the following when configuring the clock mode:

- The clock mode configuration cannot be dynamically changed. After you change the levels on DIV1 and DIV2, the mode is not changed until a hardware reset is executed (\overline{RS} low).
- The operation of the PLL circuit is affected by the operating voltage of the device. If your device operates at 5V, the PLL5V signal should be tied high at the PLL5V pin. If you have a 3-V device, tie PLL5V low.
- The ×1, ×2, and ×4 modes use an internal phase lock loop (PLL) that requires approximately 2500 cycles to lock. Delay the rising edge of \overline{RS} until at least three cycles after the PLL has stabilized. When the PLL is used, the duty cycle of the CLKIN signal is more flexible, but the minimum duty cycle should not be less than 10 nanoseconds. When the PLL is not used, no phase-locking time is necessary, but the minimum pulse width must be 45% of the minimum clock cycle.

8.3 CLKOUT1-Pin Control (CLK) Register

You can use bit 0 of the CLK register to turn off the pin for the master clock output signal (CLKOUT1). The CLK register is located at address FFE8h in I/O space and has the organization shown in Figure 8–3.

Figure 8–3. 'C2xx CLK Register — I/O-Space Address FFE8h

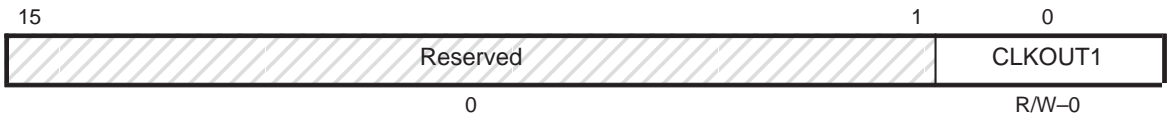

Note: 0 = Always read as zeros; R = Read access; W = Write access; value following dash (–) is value after reset.

If the CLKOUT1 bit is 1, the CLKOUT1 signal is not available at the CLKOUT1 pin; if the bit is 0, CLKOUT1 is available at the pin. At reset, this bit is cleared to 0. When the IDLE instruction puts the CPU into a power-down mode, CLKOUT1 remains active at the pin if the CLKOUT1 bit is 0. (For more information on the 'C2xx power-down mode, see section 5.8, *Power-Down Mode*, on page 5-36).

For the current status of CLKOUT1, read bit 0. To change the status, write to bit 0. When programming, allow the CLKOUT1 pin two cycles to change its state from on to off or from off to on. Bits 15–1 are reserved and are always read as 0s.

8.4 Timer

The 'C2xx features an on-chip timer with a 4-bit prescaler. This timer is a down counter that can be stopped, restarted, reset, or disabled by specific status bits. You can use the timer to generate periodic CPU interrupts.

Figure 8–4 shows a functional block diagram of the timer. There is a 16-bit main counter (TIM) and a 4-bit prescaler counter (PSC). The TIM is reloaded from the period register PRD. The PSC is reloaded from the period register TDDR. The TIM is reloaded from the period register PRD. The PSC is reloaded from the period register TDDR.

Figure 8–4. Timer Functional Block Diagram

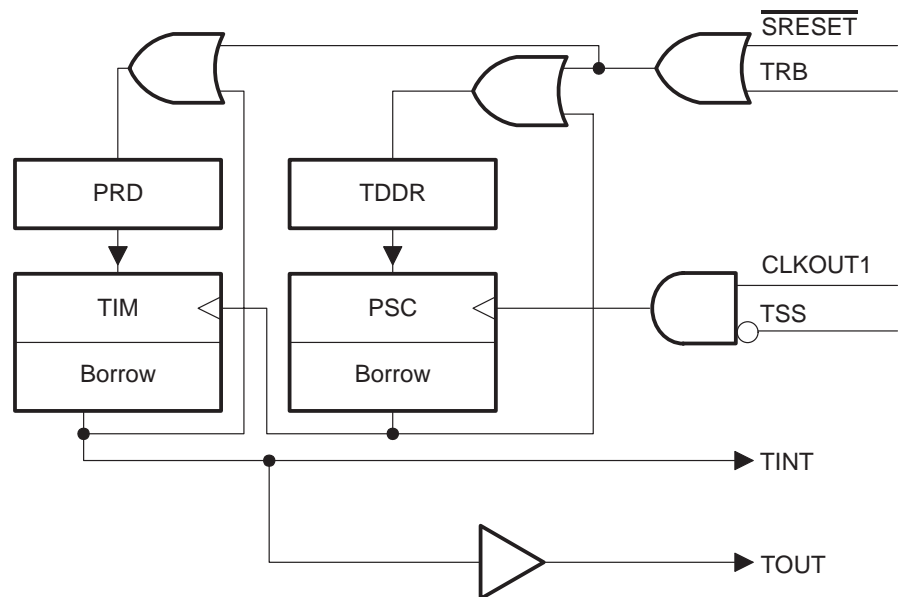

Each time a counter decrements to zero, a borrow is generated on the next CLKOUT1 cycle, and the counter is reloaded with the contents of its corresponding period register. The contents of the PRD are loaded into the TIM when the TIM decrements to 0 or when a 1 is written to the timer reload bit (TRB) in the timer control register (TCR). Similarly, the PSC is loaded with the value in the TDDR when the PSC decrements to 0 or when a 1 is written to TRB.

When the TIM decrements to 0, it generates a borrow pulse that has a duration equal to that of a CLKOUT1 cycle ($t_{c(C)}$). This pulse is sent to:

- The external timer output (TOUT) pin
- The CPU, as a timer interrupt (TINT) signal

The TINT request automatically sets the TINT flag bit in the interrupt flag register (IFR). You can mask or unmask the request with the interrupt mask register (IMR). If you are not using the timer, mask TINT so that it does not cause an unexpected interrupt.

8.4.1 Timer Operation

Here is a typical sequence of events for the timer:

- 1) The PSC decrements on each succeeding CLKOUT1 pulse until it reaches 0.
- 2) On the next CLKOUT1 cycle, the TDDR loads the new divide-down count into the PSC, and the TIM decrements by 1.
- 3) The PSC and the TIM continue to decrement in the same way until the TIM decrements to 0.
- 4) On the next CLKOUT1 cycle, a timer interrupt (TINT) is sent to the CPU, a pulse is sent to the TOUT pin, the new timer count is loaded from the PRD into the TIM, and the PSC is decremented once.

The TIM decrements by one every (TDDR+1) CLKOUT1 cycles. When PRD, TDDR, or both are nonzero, the timer interrupt rate is defined by Equation 8–1, where $t_{c(CO)}$ is the period of CLKOUT1, u is the TDDR value plus 1, and v is the PRD value plus 1. When PRD = TDDR = 0, the timer interrupt rate is (CLKOUT1 rate)/2.

Equation 8–1. Timer Interrupt Rate for Nonzero TDDR and/or PRD

$$\text{TINT rate} = \frac{1}{t_{c(CO)}} \times \frac{1}{u \times v} = \frac{1}{t_{c(CO)}} \times \frac{1}{(TDDR + 1) \times (PRD + 1)} = \frac{\text{CLKOUT1 rate}}{(TDDR + 1) \times (PRD + 1)}$$

Note:

Equation 8–1 is not valid for TDDR = PRD = 0; in this case, the timer interrupt rate defaults to (CLKOUT1 rate)/2.

In Equation 8–1 the timer interrupt rate equals the CLKOUT1 frequency ($1/t_{c(CO)}$) divided by two independent factors (u and v). Each of the two divisors is implemented with a down counter and a period register. See the timer functional block diagram, Figure 8–4, on page 8-8. The counter and period registers for the divisor u are the PSC and TDDR, respectively, both 4-bit fields of the timer control register (TCR). The counter and period registers for the divi-

or *v* are the TIM and PRD, respectively. Both are 16-bit registers mapped to I/O space.

The 4-bit TDDR (timer divide-down register) and the 4-bit PSC (prescaler counter) are contained in the timer control register (TCR) described in subsection 8.4.2. The TIM (timer counter register) and the PRD (timer period register) are 16-bit registers described in subsection 8.4.3. You can read the TCR, TIM, and PRD to obtain the current status of the timer and its counters.

Note:

Read the TIM for the current value in the timer. Read the TCR for the PSC value. Because it takes two instructions to read both the TIM and the TCR, the PSC may decrement between the two reads, making comparison of the reads inaccurate. Therefore, where precise timing measurements are necessary, you may want to stop the timer before reading the two values. (Set the TSS bit of the TCR to 1 to stop the time; clear TSS to 0 to restart the timer.)

8.4.2 Timer Control Register (TCR)

The TCR, a 16-bit register mapped to on-chip I/O space, contains the control bits that:

- Control the mode of the timer
- Specify the current count in the prescaler counter
- Reload the timer
- Start and stop the timer
- Define the divide-down value of the timer

For 'C2xx devices other than the 'C209, Figure 8–5 shows the bit layout of the TCR. Descriptions of the bits follow the figure. For a description of the 'C209 TCR, see subsection 11.4.2 on page 11-15.

Figure 8–5. 'C2xx Timer Control Register (TCR) — I/O-Space Address FFF8h

15	12	11	10	9	6	5	4	3	0
Reserved			FREE	SOFT	PSC	TRB	TSS	TDDR	
0			R/W–0	R/W–0	R/W–0	R/W–0	W–0	R/W–0	

Note: 0 = Always read as zeros; R = Read access; W = Write access; value following dash (–) is value after reset.

Bits 15–12 **Reserved.** Bits 15–12 are reserved and are always read as 0s.

Bits 11–10 **FREE, SOFT** — These bits are special emulation bits that determine the state of the timer when a breakpoint is encountered in the high-level language debugger. If the FREE bit is set to 1, then, upon a software breakpoint, the timer continues to run (that is, free runs). In this case, SOFT is a *don't care*. But if FREE is 0, then SOFT takes effect. In this case, if SOFT = 0, the timer halts the next time the TIM decrements. If the SOFT bit is 1, then the timer halts when the TIM has decremented to zero. Table 8–3 summarizes the available run and emulation modes. The default (reset) setting is FREE = 0 and SOFT = 0.

Table 8–3. 'C2xx Timer Run/Emulation Modes

FREE	SOFT	Timer Run/Emulation Mode
0	0	Stop after the next decrement of the TIM (hard stop)
0	1	Stop after the TIM decrements to 0 (soft stop)
1	0	Free run
1	1	Free run

Bits 9–6 **PSC — Timer prescaler counter.** These four bits hold the current prescale count for the timer. For every CLKOUT1 cycle that the PSC value is greater than 0, the PSC decrements by one. One CLKOUT1 cycle after the PSC reaches 0, the PSC is loaded with the contents of the TDDR, and the timer counter register (TIM) decrements by one. The PSC is also reloaded whenever the timer reload bit (TRB) is set by software. The PSC can be checked by reading the TCR, but it cannot be set directly. It must get its value from the timer divide-down register (TDDR). At reset, the PSC is set to 0.

Bit 5 **TRB — Timer reload bit.** When you write a 1 to TRB, the TIM is loaded with the value in the PRD, and the PSC is loaded with the value in the timer divide-down register (TDDR). The TRB bit is always read as zero.

Bit 4 **TSS — Timer stop status bit.** TSS stops or starts the timer. At reset, TSS is cleared to 0 and the timer immediately starts.

TSS = 0 Starts or restarts the timer.

TSS = 1 Stops the timer.

Bits 3–0 **TDDR — Timer divide-down register.** Every (TDDR + 1) CLKOUT1 cycles, the timer counter register (TIM) decrements by one. At reset, the TDDR bits are cleared to 0. If you want to increase the overall timer count by an integer factor, write this factor minus one to the four TDDR bits. When the prescaler counter (PSC) value is 0, one CLKOUT1 cycle later, the contents of the TDDR reload the PSC, and the TIM decrements by one. TDDR also reloads the PSC whenever the timer reload bit (TRB) is set by software.

8.4.3 Timer Counter Register (TIM) and Timer Period Register (PRD)

These two registers work together to provide the current count of the timer:

- The 16-bit **timer counter register (TIM)** holds the current count of the timer. The TIM decrements by one every (TDDR+1) CLKOUT1 cycles. When the TIM decrements to zero, the TINT bit of the interrupt flag register (IFR) is set (causing a pending timer interrupt), and a pulse is sent to the TOUT pin.

You can write values from 1 to 65 535 (FFFFh) to this register. At reset, this register is set to hold its maximum value of FFFFh. See Table 8–1 (page 8-2) for the address of this register.

- The 16-bit **timer period register (PRD)** holds the next starting count for the timer. When the TIM decrements to zero, in the following cycle, the contents of the PRD are loaded into the TIM. The PRD contents are also loaded into the TIM when you set the timer reload bit (TRB).

You can program the PRD to contain a value from 0 to 65 535 (FFFFh). After reset, the PRD holds its maximum value of FFFFh. See Table 8–1 (page 8-2) for the address of this register. If you are not using the timer, you can mask TINT and then use the PRD as a general-purpose data-memory location.

You control the timer's current and next periods. You can write to or read from the TIM and PRD on any cycle. You can monitor and control the count by reading from the TIM and writing the next counter period to the PRD without disturbing the current timer count. The timer will start the next period after the current count is complete. If you use TINT, you should program the PRD and TIM before unmasking TINT, to avoid unwanted interrupts.

Once a reset is initiated, the TIM begins to decrement only after reset is deasserted.

8.4.4 Setting the Timer Interrupt Rate

When the divide-down value (TDDR) is 0, you can program the timer to generate an interrupt (TINT) every 2 to 65 536 cycles by programming the period register (PRD) from 0 to 65 535 (FFFFh). When TDDR is nonzero (1 to 15), the timer interrupt rate decreases.

If TDDR, PRD, or both are nonzero, the timer interrupt rate is given by:

$$\text{TINT rate} = \frac{\text{CLKOUT1 rate}}{(\text{TDDR} + 1) \times (\text{PRD} + 1)}$$

Note:

When TDDR = PRD = 0, the timer interrupt rate defaults to (CLKOUT1 rate)/2.

As an example of setting the timer interrupt rate, suppose the CLKOUT1 rate is 10 MHz and you want to use the timer to generate a clock signal with a rate of 10 kHz. You need to divide the CLKOUT1 rate by 1000. The TDDR is loaded with 4, so that every 5 CLKOUT1 cycles, the TIM decrements by one. The PRD is loaded with the starting count (199) for the TIM. These values are verified with the TINT rate equation:

$$\text{TINT rate} = \text{CLKOUT1 rate} \times \frac{1}{(\text{TDDR} + 1) \times (\text{PRD} + 1)}$$

$$\text{TINT rate} = \frac{1 \text{ CLKOUT1 cycle}}{0.10 \times 10^{-6} \text{ s}} \times \frac{1 \text{ TINT cycle}}{(4 + 1) \times (199 + 1) \text{ CLKOUT1 cycles}}$$

$$\text{TINT rate} = \frac{10 \times 10^3 \text{ TINT cycles}}{\text{s}} = 10 \text{ kHz}$$

The PSC and the TIM would be loaded with the values from the TDDR and the PRD, respectively. Then, one CLKOUT1 cycle after the TIM decrements to 0, the timer would send an interrupt to the CPU.

8.4.5 The Timer at Hardware Reset

On a device reset, the CPU sends an $\overline{\text{SRESET}}$ signal to the peripheral circuits, including the timer. The $\overline{\text{SRESET}}$ signal has the following consequences on the timer:

- The registers TIM and PRD are loaded with their maximum values (FFFFh).
- All the bits of the TCR are cleared to zero with the following results:
 - The divide-down value is 0 (TDDR = 0 and PSC = 0).
 - The timer is started (TSS = 0).
 - The FREE and SOFT bits are both 0.

8.5 Wait-State Generator

Wait states are necessary when you want to interface the 'C2xx with slower external logic and memory. By adding wait states, you lengthen the time the CPU waits for external memory or an external I/O port to respond when the CPU reads from or writes to that memory or port. Specifically, the CPU waits one extra cycle (one CLKOUT1 cycle) for every wait state. The wait states operate on CLKOUT1 cycle boundaries.

To avoid bus conflicts, writes from the 'C2xx always take at least two CLKOUT1 cycles.

The 'C2xx offers two options for generating wait states:

- The READY signal.** With the READY signal, you can externally generate any number of wait states.
- The on-chip wait-state generator.** With this generator, you can generate zero to seven wait states.

8.5.1 Generating Wait States With the READY Signal

When READY is low, the 'C2xx waits one CLKOUT1 cycle and checks READY again. The 'C2xx will not continue executing until READY is driven high; therefore, if the READY signal is not used, it should be pulled high during external accesses.

Again, the READY pin can be used to generate any number of wait states. However, even when the 'C2xx operates at full speed, it may not respond fast enough to provide a READY-based wait state for the first cycle. For extended wait states using external READY logic, the on-chip wait-state generator should be programmed to generate at least one wait state.

The READY pin has no effect on accesses to *internal* memory or I/O registers, except in the case of the 'C209 (see Section 11.2, '*C209 Memory and I/O Spaces*, on page 11-5.) For a 'C2xx device with a boot loader, READY must be high at boot time.

8.5.2 Generating Wait States With the 'C2xx Wait-State Generator

For devices other than the 'C209, the software wait-state generator can be programmed to generate zero to seven wait states for a given off-chip memory space (lower program, upper program, data, or I/O), regardless of the state of the READY signal. This wait-state generator has the bit fields shown in Figure 8–6 and described after the figure. For a description of the 'C209 wait-

state generator, see subsection 11.4.3 on page 11-16. To avoid bus conflicts, all writes to external addresses take at least two cycles.

Figure 8–6. 'C2xx Wait-State Generator Control Register (WSGR)
— I/O-Space Address FFFCh

15	14	13	12	11	10	9	8	7	6	5	4	3	2	1	0
Reserved				ISWS			DSWS			PSUWS			PSLWS		
0				R/W–111			R/W–111			R/W–111			R/W–111		

Note: 0 = Always read as zeros; R = Read access; W = Write access; value following dash (–) is value after reset.

Bits 15–12 **Reserved.** Bits 15–12 are reserved and are always read as 0s.

Bits 11–9 **ISWS — I/O-space wait-state bits.** Bits 9–11 determine the number of wait states (0, 1, 2, 3, 4, 5, 6, or 7) that are applied to reads from and writes to off-chip I/O space. At reset, the three ISWS bits become 111, setting seven wait states for reads from and writes to off-chip I/O space.

Bits 8–6 **DSWS — Data-space wait-state bits.** Bits 6–8 determine the number of wait states (0, 1, 2, 3, 4, 5, 6, or 7) that are applied to reads from and writes to off-chip data space. At reset, the three DSWS bits become 111, setting seven wait states for reads from and writes to off-chip data space.

Bits 5–3 **PSUWS — Upper program-space wait-state bits.** Bits 3–5 determine the number of wait states (0, 1, 2, 3, 4, 5, 6, or 7) that are applied to reads from and writes to off-chip *upper* program addresses 8000h–FFFFh. At reset, the three PSUWS bits become 111, setting seven wait states for reads from and writes to off-chip upper program space.

Bits 2–0 **PSLWS — Lower program-space wait-state bits.** Bits 0–2 determine the number of wait states (0, 1, 2, 3, 4, 5, 6, or 7) that are applied to reads from and writes to off-chip *lower* program addresses 0h–7FFFh. At reset, the three PSLWS bits become 111, setting seven wait states for reads from and writes to off-chip lower program space.

Table 8–4 shows how to set the number of wait states you want for each type of off-chip memory. For example, if you write 1s to bits 0 through 5, the device will generate seven wait states for off-chip lower program memory and seven wait states for off-chip upper program memory.

Table 8–4. Setting the Number of Wait States With the 'C2xx WSGR Bits

ISWS Bits				I/O Wait States	DSWS Bits				Data Wait States	PSUWS Bits			Upper Program Wait States	PSLWS Bits			Lower Program Wait States
11	10	9	8		7	6	5	4		3	2	1		0			
0	0	0	0	0	0	0	0	0	0	0	0	0	0	0	0	0	
0	0	1	1	1	0	0	1	1	0	0	1	1	0	0	1	1	
0	1	0	2	2	0	1	0	2	0	1	0	2	0	1	0	2	
0	1	1	3	3	0	1	1	3	0	1	1	3	0	1	1	3	
1	0	0	4	4	1	0	0	4	1	0	0	4	1	0	0	4	
1	0	1	5	5	1	0	1	5	1	0	1	5	1	0	1	5	
1	1	0	6	6	1	1	0	6	1	1	0	6	1	1	0	6	
1	1	1	7	7	1	1	1	7	1	1	1	7	1	1	1	7	

In summary, the wait-state generator inserts zero to seven wait states to a given memory space, depending on the values of PSLWS, PSUWS, DSWS, and ISWS, while the READY signal remains high. The READY signal may then be driven low to generate additional wait states. If m is the number of CLKOUT1 cycles required for a particular read or write operation and w is the number of wait states added, the operation will take $(m + w)$ cycles. At reset, all WSGR bits are set to 1, making seven wait states the default for every memory space.

8.6 General-Purpose I/O Pins

The 'C2xx provides pins that can be used to supply input signals from an external device or output signals to an external device. These pins are not bound to specific uses; rather, they can provide input or output signals for a great variety of purposes. You have access to the general-purpose input pin $\overline{\text{BIO}}$ and the general-purpose output pin XF. On 'C2xx devices other than the 'C209, you also have the pins IO0, IO1, IO2, and IO3, which can each be configured as an input pin or an output pin.

8.6.1 Input Pin $\overline{\text{BIO}}$

The general-purpose input pin $\overline{\text{BIO}}$ pin provides input from an external device and is particularly helpful as an alternative to an interrupt when time-critical loops must not be disturbed. The $\overline{\text{BIO}}$ signal gives you control through three instructions, a conditional branch (BCND), a conditional call (CC), and a conditional return (RETC). Here is an example of each:

BCND *pma*, BIO

pma is a program memory address that you specify. The CPU branches to the program memory address if $\overline{\text{BIO}}$ is low.

CC *pma*, BIO

pma is a program memory address that you specify. If $\overline{\text{BIO}}$ is low, the CPU stores the return address to the top of the hardware stack and then branches to the program memory address.

RETC BIO

If $\overline{\text{BIO}}$ is low, the CPU transfers the return address from the stack to the program counter (PC) to return from a subroutine or interrupt service routine.

If $\overline{\text{BIO}}$ is not used, it should be pulled high so that a conditional branch, call, or return will not be executed accidentally.

An example of $\overline{\text{BIO}}$ timing is shown in Figure 8–7. This timing diagram is for a sequence of single-cycle, single-word instructions located in external memory. $\overline{\text{BIO}}$ must be asserted low for at least one CLKOUT1 cycle. The BCND, CC, and RETC instructions sample the $\overline{\text{BIO}}$ pin during their execute phase in the pipeline. Actual timing may vary with different instruction sequences.

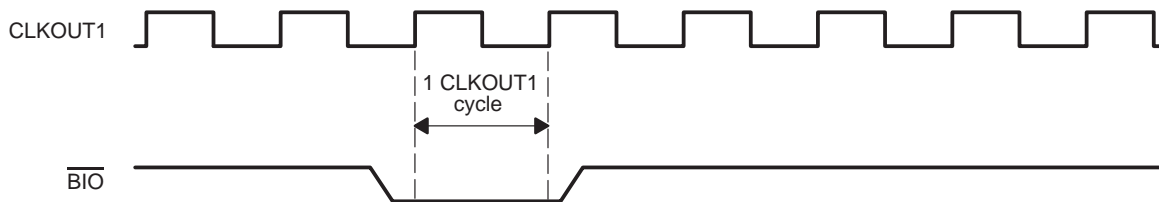
Figure 8–7. \overline{BIO} Timing Diagram Example

8.6.2 Output Pin XF

The XF pin is the external flag output pin. If you connect XF to an input pin of another processor, you can use XF as a signal to other processor. The most recent XF value is latched in the 'C2xx, and that value is indicated by the XF status bit of status register ST1. You can set XF (XF = 1) with the SETC XF (set external flag) instruction and clear it (XF = 0) with the CLRC XF (clear external flag) instruction. In addition, you can write to ST1 with the LST (load status register) instruction. During a hardware reset, XF is set to 1.

8.6.3 Input/Output Pins IO0, IO1, IO2, and IO3

For additional input/output control, 'C2xx devices other than the 'C209 have pins IO0, IO1, IO2, and IO3, which can be individually configured as inputs or outputs. These pins are software-controllable with the asynchronous serial port control register (ASPCR) and the I/O status register (IOSR). For the details of configuring and using these I/O pins, see subsection 10.3.5, *Using I/O Pins IO3, IO2, IO1, and IO0*, on page 10-15.

Synchronous Serial Port

The 'C2xx devices have a synchronous serial port that provides direct communication with serial devices such as codecs (coder/decoders) and serial A/D converters. The serial port may also be used for intercommunication between processors in multiprocessing applications.

The synchronous serial port offers these features:

- Two four-word-deep FIFO buffers
- Interrupts generated by the FIFO buffers
- A wide range of speeds of operation
- Burst and continuous modes of operation

For examples of program code for the synchronous serial port, see Appendix C, *Program Examples*.

Topic	Page
9.1 Overview of the Synchronous Serial Port	9-2
9.2 Components and Basic Operation	9-3
9.3 Controlling and Resetting the Port	9-8
9.4 Managing the Contents of the FIFO Buffers	9-15
9.5 Transmitter Operation	9-16
9.6 Receiver Operation	9-24
9.7 Troubleshooting	9-27

9.1 Overview of the Synchronous Serial Port

Both receive and transmit operations of the synchronous serial port have a four-word-deep first-in, first-out (FIFO) buffer. The FIFO buffers reduce the amount of CPU overhead inherent in servicing transmit or receive data by reducing the number of transmit or receive interrupts that occur during a transfer.

In the internal clock mode, the maximum transmission rate for both transmit and receive operations is the CPU clock rate divided by two, or (CLKOUT1 rate)/2. Therefore, the maximum rate is 10 megabits/s for a 20-MHz (50-ns) device, 14.28 megabits/s for a 28.57-MHz (35-ns) device, and 20 megabits/s for a 40-MHz (25-ns) device. Since the serial port is fully static, it also functions at arbitrarily low clocking frequencies.

Two modes of operation are provided to support a wide range of applications. Continuous mode provides operation that requires only one frame synchronization (frame sync) pulse to transmit several packets at maximum frequency. Burst mode allows transmission of a single 16-bit word following a frame sync pulse. These two modes of operation suit most of the industry-standard synchronous serial-data devices, such as codecs. This port is intended to provide a glueless interface to most of the standard codec parts. However, these modes can also be adapted for specialized synchronous interfaces.

9.2 Components and Basic Operation

The synchronous serial port has several hard-wired parts, including two FIFO buffers and six signal pins. Figure 9–1 shows how the components of the synchronous serial port are interconnected.

Figure 9–1. Synchronous Serial Port Block Diagram

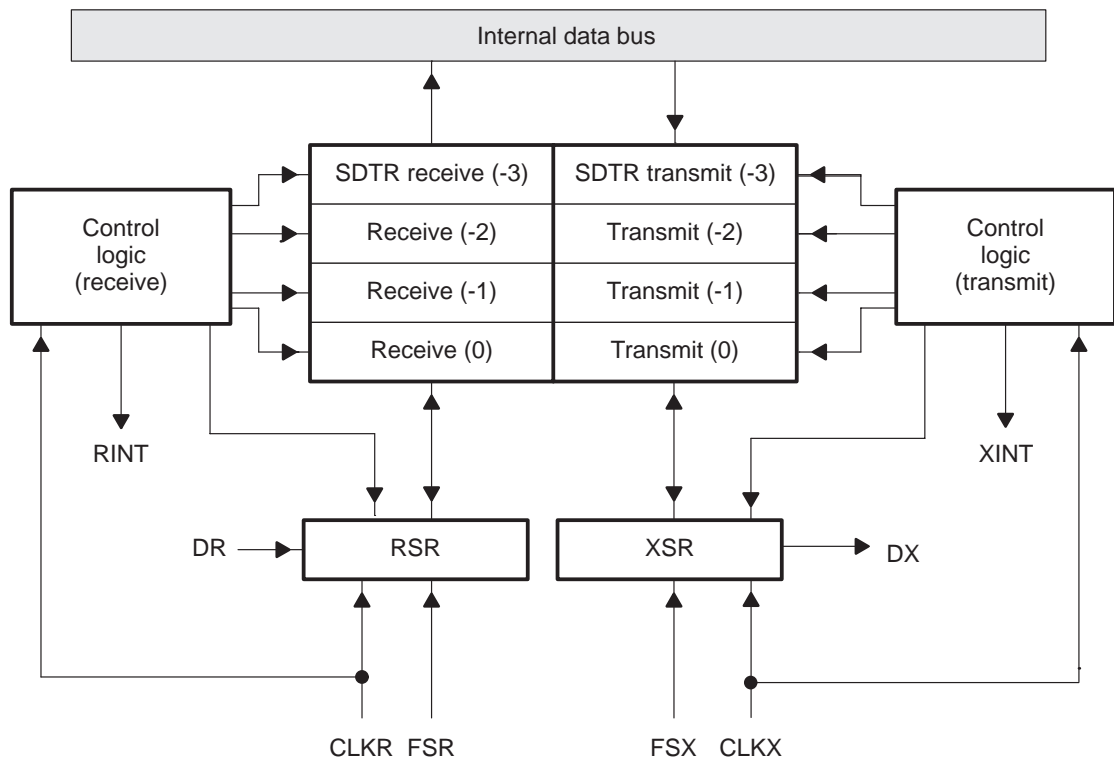

9.2.1 Signals

Serial port operation requires three basic signals:

- **Clock signal.** The clock signal (CLKX/CLKR) is used to control timing during the transfer. The timing signal for transmissions can be either generated internally or taken from an external source.
- **Frame sync signal.** The frame sync signal (FSX/FSR) is used at the start of a transfer to synchronize the transmit and receive operations. The frame sync signal for transmissions can be either generated internally or taken from an external source.

- **Data signal.** The data signal carries the actual data that is transferred in the transmit/receive operation. The data signal transmit pin (DX) of one device should be connected to the data signal receive (DR) pin on another device.

Table 9–1 describes the six pins that use these signals.

Table 9–1. SSP Interface Pins

Pin Name	Description
CLKX	<i>Transmit clock input or output.</i> The clock signal is used for clocking data from the serial port transmit shift register (XSR) to the DX pin. If the port is configured for accepting an external clock, this pin receives the clock signal. If the port is configured for generating an internal clock, this pin transmits the clock signal.
FSX	<i>Transmit frame synchronization.</i> FSX signals the start of a transmission. If the port is configured for accepting an external frame sync pulse, this pin receives the pulse. If the port is configured for generating an internal frame sync pulse, this pin transmits the signal.
DX	<i>Serial data transmit.</i> DX transmits serial data from the serial port transmit shift register (XSR).
CLKR	<i>Receive clock input.</i> CLKR receives an external clock signal for clocking the data from the DR pin into the serial port receive shift register (RSR).
FSR	<i>Receive frame synchronization.</i> FSR initiates the reception of data at the beginning of the packet.
DR	<i>Serial data receive.</i> DR receives serial data, transferring it into the serial port receive shift register (RSR).

Figure 9–2 shows how the signals are connected in a typical serial transfer between two devices. The DR pin receives serial data from the D_{OUT} signal, and the DX signal sends serial data to the D_{IN} pin. The FSX and FSR signals are both supplied from the \overline{FS} pin, and they initiate the transfers (at the beginning of a data packet). The SCK signal drives both the CLKX and CLKR signals, which clock the bit transfers.

Figure 9–2. 2-Way Serial Port Transfer With External Frame Sync and External Clock

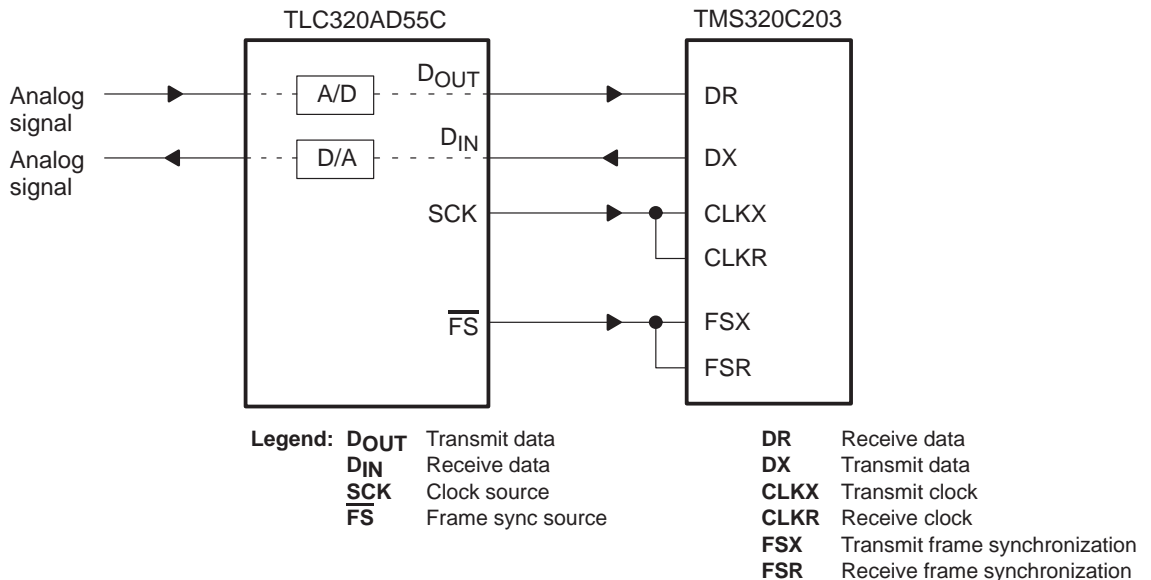

9.2.2 FIFO Buffers and Registers

The synchronous serial port (SSP) has two four-level transmit and receive FIFO buffers (shown at the center of Figure 9–1 on page 9-3).

Two on-chip registers allow you to access the FIFO buffers and control the operation of the port:

- ❑ **Synchronous data transmit and receive register (SDTR).** The SDTR, at I/O address FFF0h, is used for the top of both FIFO buffers (transmit and receive) and is the only visible part of the FIFO buffers.
- ❑ **Synchronous serial port control register (SSPCR).** The SSPCR, at I/O address FFF1h, contains bits for setting port modes, indicating the status of a data transfer, setting trigger conditions for interrupts, indicating error conditions, accepting bit input, and resetting the port. Section 9.3 includes a detailed description of the SSPCR.

Two other registers (not accessible to a programmer) control transfers between the FIFO buffers and the pins:

- ❑ **Synchronous serial port transmit shift register (XSR).** Each data word is transferred from the bottom level of the transmit FIFO buffer to the XSR. The XSR then shifts the data out (MSB first) through the DX pin.
- ❑ **Synchronous serial port receive shift register (RSR).** Each data word is accepted, one bit at a time, at the DR pin and shifted into the RSR. The RSR then transfers the word to the bottom level of the receive FIFO buffer.

9.2.3 Interrupts

The synchronous serial port (SSP) has two hardware interrupts that let the processor know when the FIFO buffers need to be serviced:

- Transmit interrupts (XINTs) cause a branch to address 000Ah in program space whenever the transmit-interrupt trigger condition is met. Set the trigger condition by setting bits FT1 and FT0 in the SSPCR (see Table 9–3 on page 9-9). XINTs have a priority level of 8 (1 being highest).
- Receive interrupts (RINTs) cause a branch to address 0008h in program space whenever the receive-interrupt-trigger condition is met. The trigger condition is selected by setting the FR1 and FR0 bits in the SSPCR (see Table 9–4 on page 9-10). RINTs have a priority level of 7.

These are maskable interrupts controlled by the interrupt mask register (IMR) and interrupt flag register (IFR).

Note:

To avoid a double interrupt from the SSP, clear the IFR bit (XINT or RINT) in the corresponding interrupt service routine, just before returning from the routine.

9.2.4 Basic Operation

Typically, transmitting a word through the serial port follows this four step process:

- 1) Initialize the serial port to the desired configuration by writing to the SSPCR.
- 2) Your software writes up to four words to the transmit FIFO buffer through the SDTR.
- 3) The transmit FIFO buffer copies the earliest-written word to the transmit shift register (XSR) when the XSR is empty.
- 4) The XSR shifts the data, bit-by-bit (MSB first), to the DX pin.
- 5) When the XSR empties, it signals the FIFO buffer, and then:
 - If the FIFO buffer is not empty, the process repeats from step 2.
 - If the FIFO buffer is empty (as specified by the FT1 and FT0 bits in the SSPCR), it sends a transmit interrupt (XINT) to request more data, and transmission stops.

Receiving a word through the serial port typically is done as follows:

- 1) Data from the DR pin is shifted, bit-by-bit (MSB first), into the receive shift register (RSR).
- 2) When the RSR is full, the RSR copies the data to the receive FIFO buffer.
- 3) The process then does one of two things, depending upon the state of the receive FIFO buffer:
 - If the receive FIFO buffer is not full, the process repeats from step 1.
 - If the receive FIFO buffer is full (as specified by the FR1 and FR0 bits in the SSPCR), it sends a receive interrupt (RINT) to the processor to request servicing.
- 4) The processor can read the received data from the receive FIFO buffer through the SDTR.

9.3 Controlling and Resetting the Port

The synchronous serial port control register (SSPCR) controls the operation of the synchronous serial port. To configure the serial port, a total of two writes to the SSPCR are necessary:

- 1) Write your choices to the configuration bits and place the port in reset by writing zeros to SSPCR bits XRST and RRST.
- 2) Write your choices to the configuration bits and take the port out of reset by writing ones to bits XRST and RRST.

Note:

Set the DLB bit of the SSPCR to zero to disable digital loopback mode, which is not normally used in serial transfers. See subsection 9.7.1, *Test Bits*, for a description of digital loopback mode.

Make sure you write your configuration choices to the SSPCR during both writes.

Figure 9–3 shows the 16-bit memory-mapped SSPCR. Following the figure is a description of each of the bits.

Figure 9–3. Synchronous Serial Port Control Register (SSPCR)
— I/O-Space Address FFF1h

15	14	13	12	11	10	9	8
FREE	SOFT	TCOMP	RFNE	FT1	FT0	FR1	FR0
R/W–0	R/W–0	R–0	R–0	R/W–0	R/W–0	R/W–0	R/W–0
7	6	5	4	3	2	1	0
OVF	IN0	XRST	RRST	TXM	MCM	FSM	DLB
R–0	R–0	R/W–1	R/W–1	R/W–0	R/W–0	R/W–0	R/W–0

Note: R=Read access; W=Write access; value following dash (–) is value after reset.

Bits 15–14

FREE, SOFT. These bits are special emulation bits that determine the state of the serial port clock when a breakpoint is encountered in the high-level language debugger. If the FREE bit is set to 1, then, upon a breakpoint, the clock continues to run (that is, free runs) and data is shifted out. In this case, SOFT is a *don't care*. If FREE = 0, then SOFT takes effect. The effects of FREE and SOFT are summarized in Table 9–2. At reset, immediate stop mode is selected (FREE = 0 and SOFT = 0).

Table 9–2. Run and Emulation Modes

FREE	SOFT	Run/Emulation Mode
0	0	Immediate stop
0	1	Stop after completion of word
1	0	Free run
1	1	Free run

Note:

If an option besides immediate stop is chosen for the receiver, an overflow error is possible. The default mode (selected at reset) is immediate stop.

- Bit 13** **TCOMP — Transmission complete.** This bit is cleared to 0 when all data in the transmit FIFO buffer has been transmitted (the buffer is empty) and is set to 1 when new data is written to the transmit FIFO buffer (the buffer is not empty).
- Bit 12** **RFNE — Receive FIFO buffer not empty bit.** This bit is 1 when the receive FIFO buffer contains data and is cleared when the buffer empties.
- Bits 11–10** **FT1, FT0 — FIFO transmit-interrupt bits.** The values you write to FT0 and FT1 set an interrupt trigger condition based on the contents of the transmit FIFO buffer. When this condition is met, a transmit interrupt (XINT) is generated and the data can be transferred out to the FIFO buffer using the OUT instruction. Table 9–3 summarizes the possible trigger conditions.

Table 9–3. Controlling Transmit Interrupt Generation by Writing to Bits FT1 and FT0

Select Bits		Generate XINT when...
FT1	FT0	
0	0	Transmit FIFO buffer can accept one or more words; XINT occurs repeatedly until the buffer is full.
0	1	Transmit FIFO buffer can accept two or more words; XINT occurs repeatedly until three words are written.
1	0	Transmit FIFO buffer can accept three or four words; XINT occurs repeatedly until two words are written.
1	1	Transmit FIFO buffer is empty (can accept 4 words); XINT occurs repeatedly until one word is written.

Bits 9–8 **FR1, FR0 — FIFO receive-interrupt bits.** The values you write to FR0 and FR1 set an interrupt trigger condition based on the contents of the receive FIFO buffer. When this condition is met, a receive interrupt (RINT) is generated and the data can be transferred in from the FIFO buffer using the IN instruction. Table 9–4 lists the possible trigger conditions.

Table 9–4. Controlling Receive Interrupt Generation by Writing to Bits FR1 and FR0

Select Bits		
FR1	FR0	Generate RINT when...
0	0	Receive FIFO buffer is not empty.
0	1	Receive FIFO buffer holds at least two words.
1	0	Receive FIFO buffer holds at least three words.
1	1	Receive FIFO buffer is full (holds four words).

Bit 7 **OVF — Overflow bit.** This bit is set whenever the receive FIFO buffer is full and another word is received in the RSR. The contents of the FIFO buffer will not be overwritten by this new word. OVF is cleared when the FIFO buffer is read.

Bit 6 **IN0 — Input bit.** This bit allows the CLKR pin to be used as a bit input. IN0 reflects the current logic level on the CLKR pin. IN0 can be tested by using a BIT or BITT instruction on the SSPCR. If the serial port is not used, IN0 can be used as a general-purpose bit input.

Bit 5 **XRST — Transmit reset bit.** This bit resets the transmitter portion of the serial interface. Set XRST to 0 to put the transmitter in reset. Set XRST to 1 to bring the transmitter out of reset.

Bit 4 **RRST — Receive reset bit.** This bit resets the receiver portion of the serial interface. Set RRST to 0 to put the receiver in reset. Set RRST to 1 to bring the receiver out of reset.

Bit 3

TXM — Transmit mode. This bit determines the source device for the frame synchronization (frame sync) pulse for transmissions. It configures the transmit frame sync pin (FSX) as an output or as an input. Note that the receive frame sync pin (FSR) is always configured as an input.

TXM = 0 An external frame sync source is selected. FSX is configured as an input and accepts an external frame sync signal. The transmitter idles until a frame sync pulse is supplied on the FSX pin.

TXM = 1 The internal frame sync source is selected. The FSX pin is configured as an output and sends a frame sync pulse at the beginning of every transmission. In this mode, frame sync pulses are generated internally when data is transferred from the SDTR to the XSR to initiate data transfers. The internally generated framing signal is synchronous with respect to CLKX.

Bit 2

MCM — Clock mode. This bit determines the source device for the clock for a serial port transfer. It configures the clock transmit pin (CLKX) as an output or as an input. Note that the clock receive pin (CLKR) is always configured as an input.

MCM = 0 An external clock source is selected. The CLKX pin is configured as an input that accepts an external clock signal.

MCM = 1 The internal clock source is selected. The CLKX pin is configured as an output driven by an internal clock source with a frequency equal to 1/2 that of CLKOUT1. Note that if MCM = 1 and DLB = 1, CLKR is also supplied by the internal source.

Bit 1

FSM — Frame synchronization mode. The FSM bit specifies whether frame synchronization pulses are required between consecutive word transfers.

FSM = 0 Continuous mode is selected. In continuous mode, one frame sync pulse (FSX/FSR) initiates the transmission/reception of multiple words.

FSM = 1 Burst mode is selected. A frame sync pulse (FSX/FSR) is required for the transmission/reception of each word.

Bit 0

DLB — Digital loopback mode. The DLB bit can be used to put the serial port in digital loopback mode.

DLB = 0 Digital loopback mode is disabled. The DR, FSR, and CLKR signals are connected to their respective device pins.

DLB = 1 Digital loopback mode is enabled. DR and FSR become internally connected to DX and FSX, respectively. The FSX and DX signals appear on the device pins, but FSR and DR do not.

TXM must be set to 1 for proper operation in digital loopback mode.

CLKX drives CLKR if you also set MCM = 1. If DLB = 1 and MCM = 0, CLKR is taken from the CLKR pin of the device. This configuration allows CLKX and CLKR to be tied together externally and supplied by a common external clock source.

9.3.1 Selecting a Mode of Operation (Bit 1 of the SSPCR)

Different applications require different modes of operation for the serial port. The synchronous serial port supports two basic modes of operation:

- Continuous mode (FSM = 0).** The continuous mode of operation requires only an initial frame sync pulse, as long as a write to SDTR (for transmission) or a read from SDTR (for reception) is executed during each transmission/reception. Use continuous mode for transmitting a continuous stream of information.
- Burst mode (FSM = 1).** In burst mode operation, a frame sync is required for every transfer, and there are periods of serial port inactivity between packet transmits. Use this mode for transmitting short packets of information.

9.3.2 Selecting Transmit Clock Source and Transmit Frame Sync Source (Bits 2 and 3 of the SSPCR)

The transmit clock is used to set the transmission rate of the serial port. Transmissions can be clocked by the internal clock source or by an external source:

- To use the **internal clock source**, set the MCM bit in the SSPCR to 1. This causes the serial port to take CLKX from the internal source. The internal clock rate is (CLKOUT1 rate)/2.
- To use an **external clock source**:
 - 1) Connect the external clock to the CLKX pin of the transmitter and to the CLKR pin of the receiver.
 - 2) Set the MCM bit to 0 in the SSPCR to cause the serial port to get CLKX from the CLKX pin.

A transmit frame sync pulse marks the start of a data transmission. The synchronous serial port can transmit using the internal frame sync source or using an external source:

- To use **internal frame sync pulses**, set the TXM bit in the SSPCR to 1.
- To use **external frame sync pulses**:
 - 1) Connect the frame sync source to the FSX pin of the transmitter and to the FSR pin of the receiver.
 - 2) Set the TXM bit in the SSPCR to 0 to enable external frame syncs.

The source configuration options are summarized in Table 9–5.

Table 9–5. Selecting Transmit Clock and Frame Sync Sources

MCM	TXM	CLKX source	FSX source
0	0	External	External
0	1	External	Internal
1	0	Internal	External
1	1	Internal	Internal

9.3.3 Resetting the Synchronous Serial Port (Bits 4 and 5 of the SSPCR)

Reset the synchronous serial port by setting XRST = 0 and RRST = 0 and then setting XRST = 1 and RRST = 1. These bits can be set individually, allowing you to reset only the transmitter or only the receiver. When a zero is written to one of these bits, activity in the corresponding section of the serial port stops.

9.3.4 Using Transmit and Receive Interrupts (Bits 8–11 of the SSPCR)

The synchronous serial port has two interrupts for managing reads and writes to the FIFO buffers. The processor can determine when the FIFO buffers need servicing in two ways:

- By polling the SSPCR register (RFNE and TCOMP bits)
- By setting up XINT and/or RINT interrupts

To determine when the FIFO buffers need servicing by polling, disable the interrupts by masking them in the interrupt mask register (IMR).

If you want to use interrupts to manage your serial transfer, then perform three steps:

- 1) Create interrupt service routines for XINTs and RINTs and include a branch to each service routine at the appropriate interrupt vector address:
 - The RINT vector is fetched from address 0008h.
 - The XINT vector is fetched from address 000Ah.
- 2) Select when you want interrupts to occur and set the FR0, FR1, FT0, and FT1 bits accordingly. You can set the FIFO buffers to generate interrupts when they are empty, when they have 1 or 2 words, when they have 3 or 4 words, or when they are full. Table 9–4 and Table 9–3 show what values to set in the FR0, FR1, FT0, and FT1 bits for each condition.
- 3) Enable the interrupts by unmasking them in the interrupt mask register (IMR).

For more information about interrupts, see Section 5.6, *Interrupts*, p. 5-15.

Note:

To avoid a double interrupt from the SSP, clear the IFR bit (XINT or RINT) in the corresponding interrupt service routine, just before returning from the routine.

9.4 Managing the Contents of the FIFO Buffers

The SDTR is a read/write register (at I/O address FFF0h) that is used to send data to the transmit FIFO buffer and to extract data from the receive FIFO buffer.

A word is written to the SDTR by the OUT instruction. When the transmit FIFO buffer is full, additional writes to the SDTR are ignored. Therefore, your program should not write a word for transmission until at least one space is available in the transmit FIFO buffer. You can set up a transmit interrupt (XINT) based on the contents of the buffer (using the FT1 and FT0 bits of the SSPCR). If your program writes words to the buffer only when the buffer is empty, you can use the transmission complete (TCOMP) bit; when the buffer is empty, TCOMP = 0.

When the receive FIFO buffer holds data, you can read the received data from the FIFO buffer through the SDTR (using the IN instruction). You can check the state of the receive buffer by reading the receive FIFO buffer not empty (RFNE) bit in the SSPCR, or you can set up a receive interrupt (RINT) based on the state of the buffer (using the FR1 and FR0 bits of the SSPCR).

9.5 Transmitter Operation

Transmitter operation is different in continuous and burst modes. Other differences also depend on whether an internal or an external frame sync is used.

9.5.1 Burst Mode Transmission With Internal Frame Sync (FSM = 1, TXM = 1)

Use burst mode transmission with internal frame sync to transfer short packets at rates lower than maximum packet frequency while using an internal frame sync generator. Place the transmitter in burst mode with internal frame sync by setting the FSM bit to 1 and the TXM bit to 1.

This mode of operation offers several features:

- A one-clock-cycle frame-sync pulse is generated internally at the beginning of each transmission.
- Continuous transmission is possible if SDTR is updated in the XINT interrupt service routine.
- Transmission can be initiated by an external event (for example, an external interrupt) or by a receive interrupt (RINT).

Generally, the transmit clock and the receive clock have the same source. This allows each bit to be transmitted from another device on a rising edge of the clock signal and received by the 'C2xx on the next falling edge of the clock signal.

Burst mode transmission with internal frame sync requires the following order of events (see Figure 9–4):

- 1) Initiate the transfer by writing to SDTR.
- 2) A frame sync pulse is generated on the next rising edge of CLKX. The frame sync pulse remains high for one clock cycle.
- 3) On the next rising edge of CLKX after FSX goes high, XSR is loaded with the value at the bottom of the FIFO buffer, and the frame sync pulse goes low. Additionally, the first data bit (MSB first) is driven on the DX pin. If the FIFO buffer becomes empty during this operation, then it generates XINT to request more data.
- 4) The rest of the bits are then shifted out. Each new bit is transmitted at each consecutive rising edge of CLKX.
- 5) If the FIFO buffer still holds a word or words to be transmitted, another frame sync pulse is generated in parallel to the driving of the LSB on the DX pin, and transmission continues at step 3. If the FIFO is empty, transmission is complete.

If the SDTR is loaded with a new word while the transmit FIFO buffer is full, the new word will be lost; the FIFO buffer will not accept any more than four words.

The burst mode can be discontinued (changed to continuous mode) only by a serial-port or device reset. Changing the FSM bit during transmit or halt will not necessarily cause a switch to continuous mode.

Figure 9–4. Burst Mode Transmission With Internal Frame Sync and Multiple Words in the Buffer

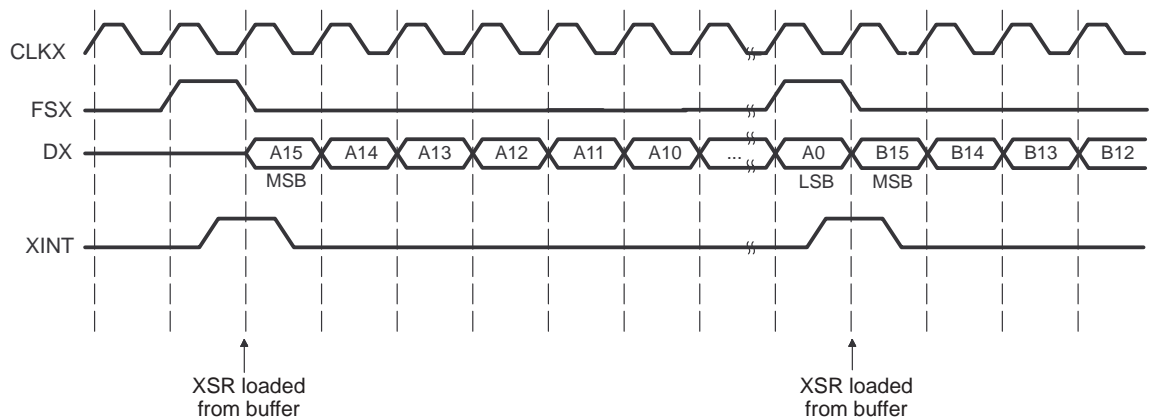

9.5.2 Burst Mode Transmission With External Frame Sync (FSM = 1, TXM = 0)

Use burst mode transmission with external frame sync to transfer short packets at rates lower than maximum packet frequency while using an external frame sync generator. Place the transmitter in burst mode with external frame sync by setting the FSM bit to 1 and the TXM bit to 0.

This mode of operation offers several features:

- A frame sync pulse initiates transmission.
- If a frame sync pulse occurs after the initial one, then transmission restarts.
- Transmission can be initiated by an external event (for example, an external interrupt) or by a serial port receive interrupt (RINT).

Generally, the transmit clock and the receive clock have the same source. This allows each bit to be transmitted from another device on a rising edge of the clock signal and received by the 'C2xx on the next falling edge of the clock signal.

Burst mode transmission with external frame sync involves the following order of events (see Figure 9–5):

- 1) A frame sync pulse initiates the transmission. The pulse is sampled on the falling edge of CLKX. After the falling edge of CLKX, the contents of the first entry in the FIFO buffer are transferred to the XSR. If the FIFO buffer becomes empty during this operation, it generates a XINT to request more data.
- 2) On the next rising edge of CLKX after FSX goes high, DX is driven with the first bit (MSB) of the word to be transmitted.
- 3) The frame sync goes low (and remains low during word transmission).
- 4) Once FSX goes low, the rest of the bits are shifted out.
- 5) When all of the bits in the word are transferred, the port waits for a new frame sync pulse.

If the SDTR is loaded with a new word while the transmit FIFO buffer is full, the new word will be lost; the FIFO buffer will not accept any more than four words.

If a frame sync pulse occurs during transmission, transmission is restarted. If another value has been written to the SDTR, a new word is sent; otherwise, the last word in the XSR is sent.

The burst mode can be discontinued (changed to continuous mode) only by a serial-port or device reset. Changing the FSM bit during transmit or halt will not necessarily cause a switch to continuous mode.

Figure 9–5. Burst Mode Transmission With External Frame Sync

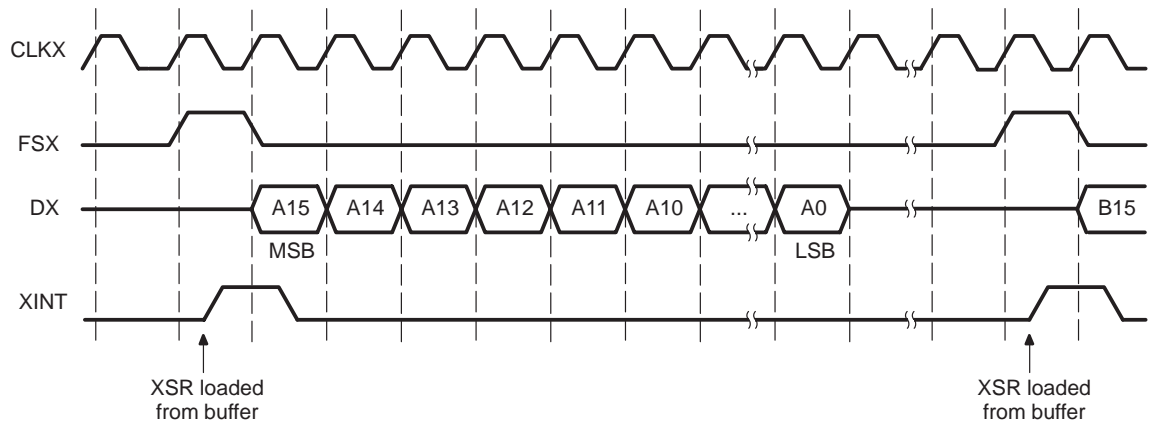

9.5.3 Continuous Mode Transmission With Internal Frame Sync (FSM = 0, TXM = 1)

Use continuous mode transmission with internal frame sync to transfer long packets at maximum packet frequency while using an internal frame sync generator. Place the transmitter in continuous mode with internal frame sync by setting the FSM bit to 0 and the TXM bit to 1.

In continuous mode, frame sync pulses are not necessary after the initial pulse for consecutive packet transfers. A frame sync is generated only for the first transmission. As long as the FIFO buffer has new values to transmit, the mode continues. Transmission halts when the buffer empties. If SDTR is written to after the halt, the device starts a new continuous mode transmission.

This mode of operation offers several features:

- A write to the SDTR begins the transmission.
- A one-clock-cycle frame-sync pulse is generated internally at the beginning of the transmission.
- As long as data is maintained in the transmit FIFO buffer, the mode continues.
- Failure to update the FIFO buffer causes the process to end.

Generally, the transmit clock and the receive clock have the same source. This allows each bit to be transmitted from another device on a rising edge of the clock signal and received by the 'C2xx on the next falling edge of the clock signal.

As illustrated by Figure 9–6, in this mode, the port operates as follows:

- 1) The transfer is initiated by a write to the SDTR.
- 2) The write to the SDTR causes a frame sync pulse to be generated on the next rising edge of CLKX. The frame sync pulse remains high for one clock cycle.
- 3) On the next rising edge of CLKX after FSX goes high, the XSR is loaded with the earliest-written value from the transmit FIFO buffer, and the frame sync pulse goes low. Additionally, the first data bit (MSB first) is driven on the DX pin. If the FIFO buffer becomes empty during this operation, then it generates a XINT to request more data.
- 4) The rest of the bits are then shifted out. Each new bit is transmitted at the rising edge of CLKX.
- 5) Once the entire word in the XSR is shifted out, the next word is loaded in and the first bit of the word is placed on the DX pin. Then, the process repeats beginning with step four. If a new word is not in the transmit FIFO buffer, the process ends.

If the SDTR is loaded with a new word while the transmit FIFO buffer is full, the new word will be lost; the FIFO buffer will not accept any more than four words.

Continuous mode can be discontinued (changed to burst mode) only by a serial-port or device reset. Changing the FSM bit during transmit or halt will not necessarily cause a switch to burst mode.

Figure 9–6. Continuous Mode Transmission With Internal Frame Sync

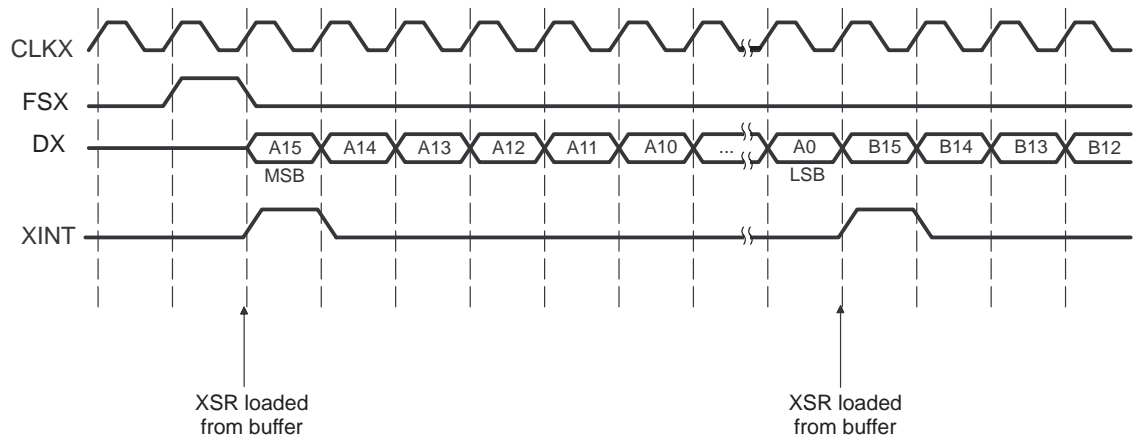

9.5.4 Continuous Mode Transmission with External Frame Sync (FSM=0, TXM=0)

Use continuous mode transmission with external frame sync to transfer long packets at maximum packet frequency while using an external frame sync generator. Place the transmitter in continuous mode with external frame sync by setting the FSM bit to 0 and the TXM bit to 0.

In continuous mode, frame sync pulses are not necessary after the initial pulse for consecutive packet transfers. A frame sync is generated only for the first transmission. As long as the FIFO buffer has new values to transmit, the mode continues. Transmission halts when the buffer empties. If SDTR is written to after the halt, the device starts a new continuous mode transmission.

This mode of operation offers several features:

- Only one frame sync is necessary for the transmission of consecutive packets.
- If the FIFO buffer is not empty, the mode continues. If the FIFO buffer is empty, the process ends.

Generally, the transmit clock and the receive clock have the same source. This allows each bit to be transmitted from another device on a rising edge of the clock signal and received by the 'C2xx on the next falling edge of the clock signal.

Continuous mode transmission with external frame sync requires the following order of events (see Figure 9–7):

- 1) A frame sync pulse initiates the transmission. The pulse is sampled on the falling edge of CLKX. After the falling edge of CLKX, the contents of the current word in the transmit FIFO buffer are transferred to the XSR. If the FIFO buffer becomes empty during this operation, then it generates a XINT to request more data.
- 2) On the next rising edge of CLKX after FSX goes high, DX is driven with the first bit (MSB) of the word to be transmitted.
- 3) The frame sync goes low (and remains low during word transmission).
- 4) Once FSX goes low, the rest of the bits are shifted out.
- 5) Once the entire word in the XSR is shifted out, the next word is loaded in and the first bit of the word is placed on the DX pin. Then, the process repeats beginning with step four. If a new word is not in the transmit FIFO buffer, then the process ends.

If the SDTR is loaded with a new word while the transmit FIFO buffer is full, the new word will be lost; the FIFO buffer will not accept any more than four words.

The continuous mode can be discontinued (changed to burst mode) only by a serial-port or device reset. Changing the FSM bit during transmit or halt will not necessarily cause a switch to burst mode.

Figure 9–7. Continuous Mode Transmission With External Frame Sync

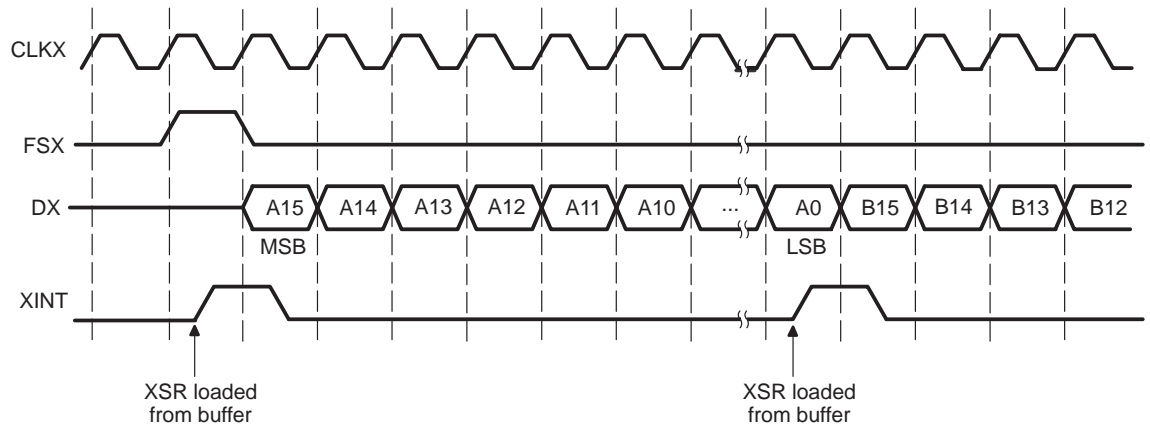

9.6 Receiver Operation

Receiver operation is different in continuous and burst modes. The receiver does not generate frame sync pulses; it always takes the frame sync pulse as an input.

In selecting the proper receive mode, note that the mode for the receiver must match the mode for the transmitter.

If all four words of the receive FIFO buffer have been filled, the buffer will not accept additional words. If a fifth write is attempted, the overflow (OVF) bit of the SSP control register (SSPCR) is set to 1.

9.6.1 Burst Mode Reception

Use burst mode receive to transfer short packets at rates lower than maximum packet frequency.

This mode of operation offers these features:

- The data packet is marked by the frame sync pulse on FSR.
- Reception of data can be maintained continuously.

Generally, the transmit clock and the receive clock have the same source. This allows each bit to be transmitted from another device on a rising edge of the clock signal and received by the 'C2xx on the next falling edge of the clock signal.

The following events occur during a burst mode receive operation (see Figure 9–8):

- 1) A frame sync pulse initiates the receive operation. This event is sampled on the falling edge of CLKR.
- 2) On the next falling edge of CLKR after the falling edge of FSR, the first bit (MSB) is shifted into the receive shift register (RSR).
- 3) The rest of the bits in the word are then shifted into RSR one at a time at each consecutive falling edge of CLKR.
- 4) After all bits have been received, if the receive FIFO buffer is not full, the contents of the RSR are copied into the receive FIFO buffer. If the FIFO buffer becomes full during this operation, an interrupt (RINT) is sent to the CPU, and the overflow bit (OVF) of the SSPCR is set.
- 5) The receive operation is started again after the next frame sync pulse. However, the received word can be loaded into the FIFO buffer only if the buffer is empty; otherwise, the word is lost.

If a frame sync pulse occurs during reception, reception is restarted, and the bits that were shifted into the RSR before the pulse are lost.

Figure 9–8. Burst Mode Reception

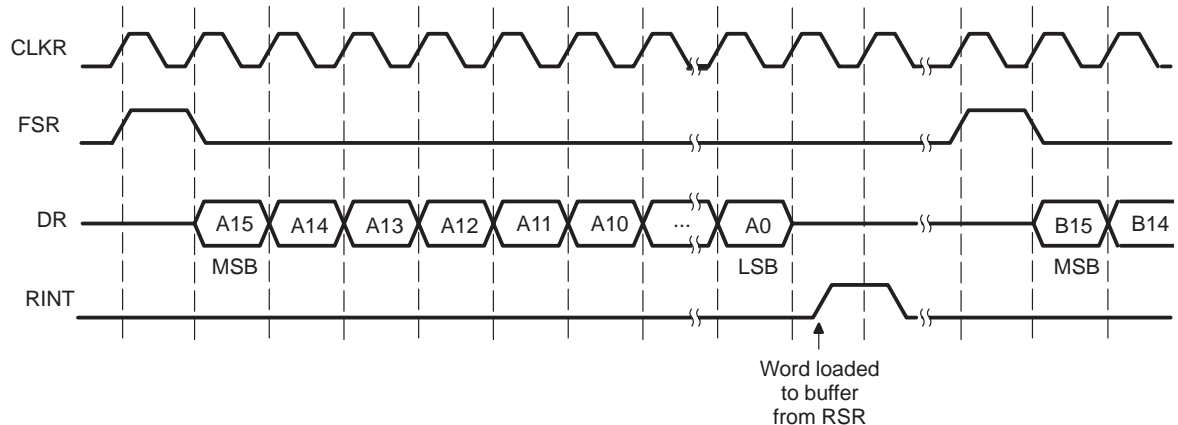

9.6.2 Continuous Mode Reception

Use continuous mode receive to transfer long packets at maximum packet frequency.

This mode of operation offers several features:

- Only the first frame sync signal is necessary to start the reception of consecutive words.
- As long as the receive FIFO buffer is not allowed to overflow, the mode continues. Overflow is indicated by the OVF bit in the SSPCR.
- Reception can be maintained continuously.

Generally, the transmit clock and the receive clock have the same source. This allows each bit to be transmitted from another device on a rising edge of the clock signal and received by the 'C2xx on the next falling edge of the clock signal.

As shown in Figure 9–9, the following events occur during a continuous mode receive operation:

- 1) The receive operation begins when a frame sync signal is detected on the falling edge of CLKR.
- 2) On the first falling edge of CLKR after the frame sync signal goes low, the first bit (MSB) is shifted into the RSR.

- 3) The remaining bits in the word are then shifted into the RSR, one by one at the falling edge of each consecutive clock cycle.
- 4) After all bits have been received, if the FIFO buffer is not full, the contents of the RSR are copied to the receive FIFO buffer. If the receive FIFO buffer does become full, an interrupt (RINT) is sent to the CPU, and if overflow has occurred, the overflow (OVF) bit of the SSPCR is set.
- 5) The process then repeats itself, except that there are no additional frame sync pulses.

If a frame sync pulse occurs during reception, then reception is restarted and the bits in the current word that were shifted into the RSR before the pulse are lost.

If the FIFO buffer becomes full, no new words will be received into the buffer until at least one word has been read from the buffer (through the SDTR). Once the continuous reception is started, the port will always be reading in the values on the DR pin. To stop continuous mode reception, reset the port.

Figure 9–9. Continuous Mode Reception

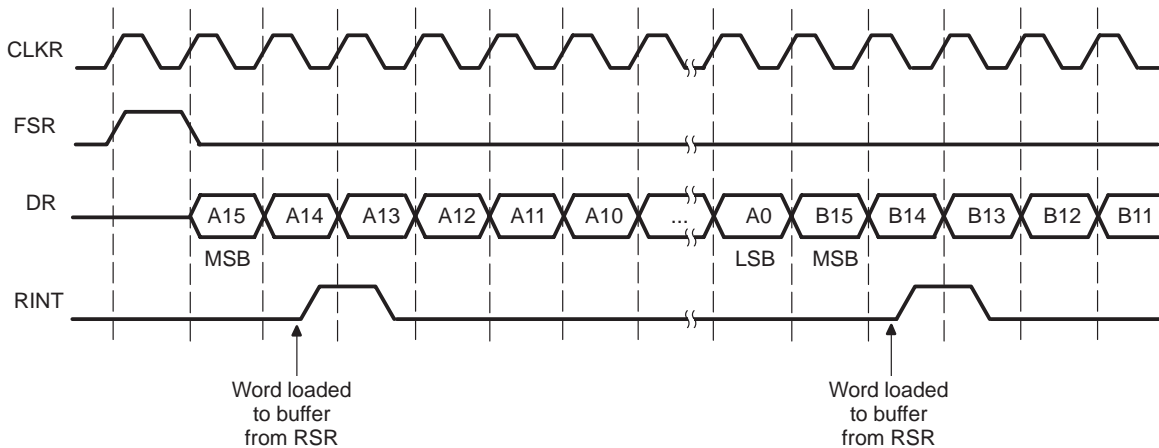

9.7 Troubleshooting

The synchronous serial port uses three bits for troubleshooting and testing. In addition to using these three bits, you must be able to identify special error conditions that may occur in actual transfers. Error conditions result from an unprogrammed event occurring to the serial port. These conditions are operational errors such as overflow, underflow, or a frame sync pulse during a data transfer.

This section describes how the serial port handles these errors and the state it acquires during these error conditions. The types of errors differ slightly in burst and continuous modes.

9.7.1 Test Bits

Three bits in the SSPCR help you test the synchronous serial port. The digital loopback mode bit (DLB) can be used to internally connect the receive data and frame sync signals to the transmit data and frame sync signals on the same device. The FREE and SOFT bits allow emulation modes that stop the port either immediately or after the transmission of the current word. Figure 9–10 shows the bits that are used for troubleshooting. The list items following the figure describe the functions of these bits.

Figure 9–10. Test Bits in the SSPCR



- **FREE and SOFT** are special emulation bits that allow you to determine the state of the serial port clock when a breakpoint is encountered in the high-level language debugger. If the FREE bit is set to 1, then, upon a software breakpoint, the clock continues to run (that is, free runs) and data is shifted out. In this case, SOFT is a *don't care*. But if FREE is 0, then SOFT takes effect. If SOFT = 0, then the clock immediately stops, thus aborting any transmission. If the SOFT bit is 1, the particular transmission continues until completion of the word, and then the clock halts. Table 9–6 summarizes the available run and emulation modes.

Table 9–6. Run and Emulation Modes

FREE	SOFT	Run/Emulation Mode
0	0	Immediate stop
0	1	Stop after completion of word
1	0	Free run
1	1	Free run

Note:

If an option besides immediate stop is chosen for the receiver, an overflow error is possible. The default mode (selected at reset) is immediate stop.

DLB enables or disables digital loopback mode:

- To enable the digital loopback mode, set DLB = 1.
- To disable the digital loopback mode, set DLB = 0.

When you enable digital loopback mode, the transmit data (DX) and frame sync (FSX) signals become internally connected to the receive data (DR) and frame sync (FSR) signals. After writing code for both the transmitter and the receiver, you can then test whether the code is working properly and also check that the serial port is functioning. In addition, if both the DLB and MCM bits are 1, the transmit clock signal is also connected internally to the receive clock signal.

The serial port operates normally when you disable digital loopback mode; that is, no transmit and receive signals are internally connected together.

Note:

To configure the serial port, a total of two writes to the SSPCR are necessary:

- 1) First, write your choices to the configuration bits and place the port in reset by writing zeros to XRST and RRST.
- 2) Second, write your choices to the configuration bits and take the port out of reset by writing ones to the XRST and RRST bits.

9.7.2 Burst Mode Error Conditions

The following are descriptions of errors that can occur in burst mode:

- ❑ **Underflow.** Underflow is caused if an external FSX occurs, and there are no new words in the transmit FIFO buffer. Upon receiving the FSX (generally, from an external clock source), transmitter resends the previous word; that is, the value in XSR will be transmitted again.
- ❑ **Overflow.** This error occurs when the device has not read incoming data and more data is being sent (indicated by a frame sync pulse on FSR). The OVF bit of the SSPCR is set to indicate overflow. The processor halts updates to the FIFO buffer until the SDTR is read. Thus, any further data sent is lost.
- ❑ **Frame sync pulse during a reception.** If the frame sync occurs during a reception, the present reception is aborted and a new one begins. The data that was being loaded into the RSR is lost, but the data in the FIFO buffer is not. No RSR-to-FIFO buffer copy occurs until all 16 bits in a word have been received.
- ❑ **Frame sync pulse during a transmission.** Another error results when a frame sync occurs while a transmission is in process. If the data in the XSR is being driven on the DX pin when the frame sync pulse occurs, then the present transmission is aborted. Then, whatever data is next in the FIFO buffer at the time of the frame sync pulse is transferred to XSR for transmission.

9.7.3 Continuous Mode Error Conditions

The following are descriptions of continuous mode errors and how the port responds to them:

- ❑ **Underflow.** Underflow occurs when the XSR is ready to accept new data but there are no new words in the transmit FIFO buffer. Underflow errors are fatal to a transmission; it causes transmission to halt. For as long as the transmit FIFO buffer is empty, frame sync pulses are ignored. If new data is then written to the SDTR, another frame sync pulse is required (or generated, if you are using internal frame syncs) to restart continuous mode transmission.

Your software can do the following to determine how many words are left in the transmit FIFO buffer:

- Test for the condition $TCOMP = 0$. When the transmit FIFO buffer empties, the TCOMP bit of the SSPCR is set to 0.
- Cause an interrupt (XINT) to occur based on the contents of the buffer. You can use bits FT1 and FT0 in the SSPCR to set the interrupt trigger conditions shown in Table 9–3 on page 9-9.

- ❑ **Overflow.** Overflow occurs when the RSR has new data to pass to the receive FIFO buffer but the FIFO buffer is full. Overflow errors are fatal to a reception. For as long as the FIFO buffer is full, any incoming words will be lost. To restart reception, make space in the buffer by reading from it (through the SDTR).
- ❑ **Frame sync pulse during a transmission.** After the initial frame sync, no others should occur during transmission. If a frame sync pulse occurs during a transmission, the current transmission is aborted, and a new transmit cycle begins.
- ❑ **Frame sync pulse during a reception.** After the initial frame sync, no others should occur during reception. If a frame sync pulse occurs during a reception, the current packet of data is lost. On any FSR pulse, the RSR bit counter is reset; therefore, the data that was being shifted into the RSR from the the DR pin is lost.

Asynchronous Serial Port

The 'C2xx has an asynchronous serial port that can be used to transfer data to and from other devices. The port has several important features:

- Full-duplex transmit and receive operations at the maximum transfer rate
- Data-word length of eight bits for both transmit and receive
- Capability for using one or two stop bits
- Double buffering in all modes to transmit and receive data
- Adjustable baud rate of up to 250,000 10-bit characters per second
- Automatic baud-rate detection logic

For examples of program code for the asynchronous serial port, see Appendix C, *Program Examples*.

Topic	Page
10.1 Overview of the Asynchronous Serial Port	10-2
10.2 Components and Basic Operation	10-3
10.3 Controlling and Resetting the Port	10-7
10.4 Transmitter Operation	10-19
10.5 Receiver Operation	10-20

10.1 Overview of the Asynchronous Serial Port

The on-chip asynchronous serial port (ASP) provides easy serial data communication between host CPUs and the 'C2xx or between two 'C2xx devices. The asynchronous mode of data communication is often referred to as UART (universal asynchronous receive and transmit). For transmissions, data written to a transmit register is converted from an 8-bit parallel form to a 10- or 11-bit serial form (the eight bits preceded by one start bit and followed by one or two stop bits). Each of the ten or eleven bits is transmitted sequentially (LSB first) to a transmit pin. For receptions, data is received one bit at a time (LSB first) at a receive pin (one start bit, eight data bits, and one or two stop bits). The received bits are converted from serial form to parallel form and stored in the lower eight bits of a 16-bit receive register. Errors in data transfers are indicated by flags and/or interrupts.

The maximum rate for transmissions and receptions is determined by the rate of the internal baud clock, which operates at a fraction of the rate of CLKOUT1. The exact fraction is determined by the value in the 16-bit programmable baud-rate divisor register (BRD). For receptions, you may enable (through software) the auto-baud detection logic, which allows the ASP to lock to the incoming data rate.

10.2 Components and Basic Operation

Figure 10–1 shows the main components of the asynchronous serial port.

Figure 10–1. Asynchronous Serial Port Block Diagram

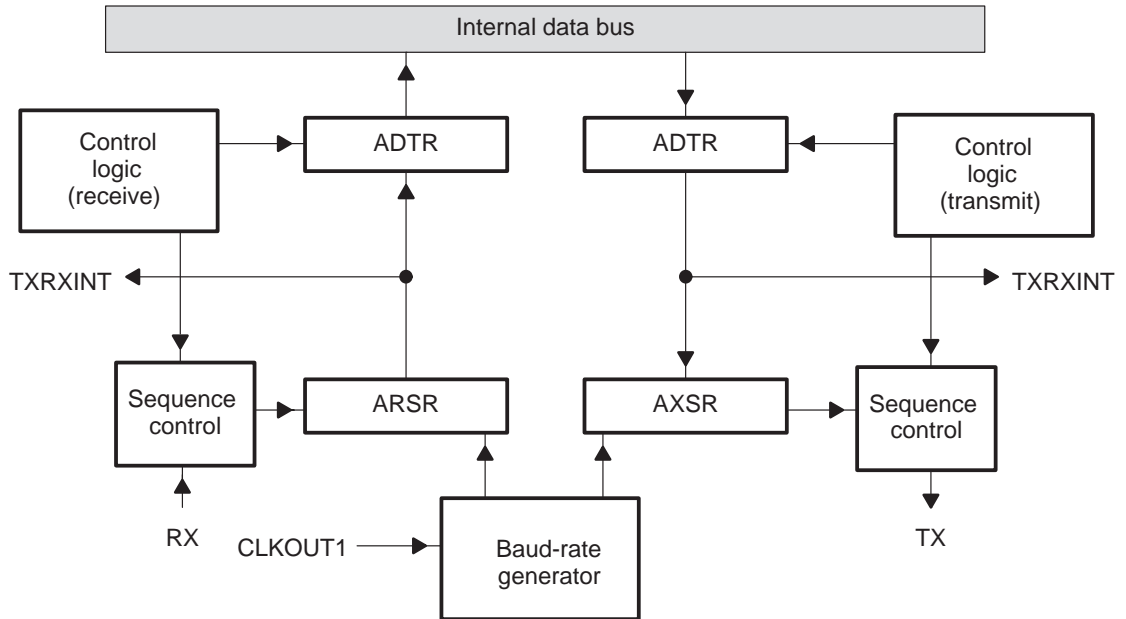

10.2.1 Signals

Two types of signals are used in asynchronous serial port (ASP) operations:

- **Data signal.** A data signal carries data from the transmitter to the receiver. Data is sent through the transmit pin (TX) on the transmitter and accepted through the receive pin (RX) on the receiver. One-way serial port transmission requires one data signal; two-way transmission requires two data signals.
- **Handshake signal.** The data transfer can be improved by using bits IO0–IO3 of the ASP control register (ASPCR) for handshaking.

Data is transmitted on a character-by-character basis. Each data frame contains a start bit, eight data bits, and one or two stop bits. The transmit and receive sections are both double-buffered to allow continuous data transfers.

The pins used by the asynchronous serial port are summarized in Table 10–1. Each of these pins has an associated signal with the same name.

Table 10–1. Asynchronous Serial Port Interface Pins

Pin Name	Description
TX	<i>Asynchronous serial port data transmit pin.</i> Transmits serial data from the asynchronous serial port transmit shift register (AXSR).
RX	<i>Asynchronous serial port data receive pin.</i> Receives serial data into the asynchronous serial port receive shift register (ARSR).
IO0	<i>General purpose I/O pin 0.</i> Can be used for general purpose I/O or for handshaking by the UART.
IO1	<i>General purpose I/O pin 1.</i> Can be used for general purpose I/O or for handshaking by the UART.
IO2	<i>General purpose I/O pin 2.</i> Can be used for general purpose I/O or for handshaking by the UART.
IO3	<i>General purpose I/O pin 3.</i> Can be used for general purpose I/O or for handshaking by the UART.

10.2.2 Baud-Rate Generator

The baud-rate generator is a clock generator for the asynchronous serial port. The output rate of the generator is a fraction of the CLKOUT1 rate and is controlled by a 16-bit register, BRD, that you can read from and write to at I/O address FFF7h. For a CLKOUT1 frequency of 40 MHz, the baud-rate generator can generate baud rates as high as 2.5 megabits/s (250,000 characters/s) and as low as 38.14 bits/s (3.81 characters/s).

10.2.3 Registers

Four on-chip registers allow you to transmit and receive data and to control the operation of the port:

- ❑ **Asynchronous data transmit and receive register (ADTR).** The ADTR is a 16-bit read/write register for transmitting and receiving data. Data written to the lower eight bits of the ADTR is transmitted by the asynchronous serial port. Data received by the port is read from the lower eight bits of the ADTR. The upper byte is read as zeros. The ADTR is an on-chip register located at address FFF4h in I/O space.
- ❑ **Asynchronous serial port control register (ASPCR).** The ASPCR, at I/O address FFF5h, contains bits for setting port modes, enabling or disabling the automatic baud-rate detection logic, selecting the number of stop bits, enabling or disabling interrupts, setting the default level on the TX pin, configuring pins IO3–IO0, and resetting the port. Subsection 10.3.1 gives a detailed description of the ASPCR.

- ❑ **I/O status register (IOSR).** Bits in the IOSR indicate detection of the incoming baud rate, various error conditions, the status of data transfers, detection of a break on the RX pin, the status of pins IO3–IO0, and detection of changes on pins IO3–IO0. The IOSR is at address FFF6h in I/O space. For detailed descriptions of the bits in the IOSR, see subsection 10.3.2.
- ❑ **Baud-rate divisor register (BRD).** The 16-bit value in the BRD is a divisor used to determine the baud rate for data transfers. BRD (at address FFF7h in I/O space) is either loaded by software or is loaded by the port when the automatic baud-rate detection logic is enabled and samples the incoming baud rate. Subsection 10.3.3 describes how to determine the BRD value that will produce the desired baud rate.

Two other registers (not accessible to a programmer) control transfers between the ADTR and the pins:

- ❑ **Asynchronous serial port transmit shift register (AXSR).** During transmissions, each data character is transferred from the ADTR to the AXSR. The AXSR then shifts the character out (LSB first) through the TX pin.
- ❑ **Asynchronous serial port receive shift register (ARSR).** During receptions, each data character is accepted, one bit at a time (LSB first), at the RX pin and shifted into the ARSR. The ARSR then transfers the character to the ADTR.

10.2.4 Interrupts

The asynchronous serial port has one hardware interrupt (TXRXINT), which can be generated by various events (described in subsection 10.3.6). TXRXINT leads the CPU to interrupt vector location 000Ch in program memory. The branch at that location should lead to an interrupt service routine that identifies the cause of the interrupt and then acts accordingly. TXRXINT has a priority level of 9 (1 being highest).

TXRXINT is a maskable interrupt controlled by the interrupt mask register (IMR) and interrupt flag register (IFR).

Note:

To avoid a double interrupt from the ASP, clear the IFR bit (TXRXINT) in the corresponding interrupt service routine, just before returning from the routine.

10.2.5 Basic Operation

Figure 10–2 shows a typical serial link between a 'C2xx device and any host CPU. In this mode of communication, any 8-bit character can be transmitted or received serially by way of the transmit data pin (TX) or the receive data pin (RX), respectively. The data transmitted or received through the TX and RX pins will be at TTL level. However, if the hosts are separated by a few feet or more, the serial data lines must be buffered through line-drivers (RS-232 or RS-485, depending on the application).

When an 8-bit character is written into the lower eight bits of the ADTR, the data, in parallel form, is converted into a 10- or 11-bit character with one start bit and one or two stop bits. This new 10- or 11-bit character is then converted into a serial data stream and transmitted through the TX pin one bit at a time. The bit duration is determined by the baud clock rate. The baud-rate divisor register (BRD) is programmable and takes a 16-bit value, providing all the industry-standard baud rate values.

Similarly, if a 10- or 11-bit data stream reaches the RX pin, the serial port samples the bit at the transmitted baud rate and converts the serial stream into an 8-bit parallel data character. The received 8-bit character is stored in the lower eight bits of the ADTR.

Figure 10–2. Typical Serial Link Between a 'C2xx Device and a Host CPU

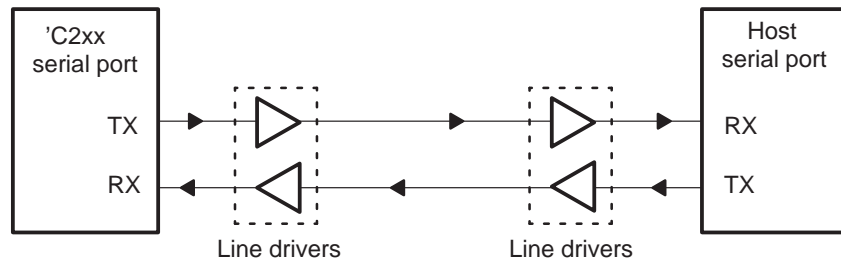

10.3 Controlling and Resetting the Port

The asynchronous serial port is programmed through three on-chip registers mapped to I/O space: the asynchronous serial port control register (ASPCR), the I/O status register (IOSR), and the baud-rate divisor register (BRD). This section describes the contents of each of these registers and also explains the use of associated control features.

10.3.1 Asynchronous Serial Port Control Register (ASPCR)

The ASPCR controls the operation of the asynchronous serial port. Figure 10–3 shows the fields in the 16-bit memory-mapped ASPCR and bit descriptions follow the figure. All of the bits in the register are read/write, with the exception of the reserved bits (12–10). The ASPCR is an on-chip register mapped to address FFF5h in I/O space.

Figure 10–3. Asynchronous Serial Port Control Register (ASPCR)
— I/O-Space Address FFF5h

15	14	13	12	11	10	9	8
FREE	SOFT	URST	Reserved			DIM	TIM
R/W–0	R/W–0	R/W–0	0			R/W–0	R/W–0
7	6	5	4	3	2	1	0
RIM	STB	CAD	SETBRK	CIO3	CIO2	CIO1	CIO0
R/W–0	R/W–0	R/W–0	R/W–0	R/W–0	R/W–0	R/W–0	R/W–0

Note: 0 = Always as zeros; R=Read access; W=Write access; value following dash (–) is value after reset.

- Bit 15** **FREE.** This bit sets the port to function in emulation or run mode.
- FREE = 0 Emulation mode is selected. SOFT then determines the which emulation mode is enabled.
- FREE = 1 Free run mode is selected.
- Bit 14** **SOFT.** This bit is enabled when the FREE bit is 0. It determines the emulation mode.
- SOFT = 0 Process stops immediately.
- SOFT = 1 Process stops after word completion.
- Bit 13** **URST — Reset asynchronous serial port bit.** URST is used to reset the asynchronous serial port. At reset, URST = 0.
- URST = 0 The port is in reset.
- URST = 1 The port is enabled.

- Bits 12–10** **Reserved.** Always read as 0s.
- Bit 9** **DIM — Delta interrupt mask.** DIM selects whether or not delta interrupts are asserted on the TXRXINT interrupt line. A delta interrupt is generated by a change on one of the general-purpose I/O pins (IO3, IO2, IO1, or IO0).
- DIM = 0 Disables delta interrupts.
- DIM = 1 Enables delta interrupts.
- Bit 8** **TIM — Transmit interrupt mask.** TIM selects whether transmit interrupts are asserted on the TXRXINT interrupt line. A transmit interrupt is generated by THRE (transmit register empty indicator in the IOSR) when the transmit register (ADTR) empties.
- TIM = 0 Disables transmit interrupts.
- TIM = 1 Enables transmit interrupts.
- Bit 7** **RIM — Receive interrupt mask.** RIM selects whether receive interrupts are asserted on the TXRXINT interrupt line. A receive interrupt is generated by one of these indicators in the IOSR: BI (break interrupt), FE (framing error), OE (overflow error), or DR (data ready).
- RIM = 0 Disables receive interrupts.
- RIM = 1 Enables receiver interrupts.
- Bit 6** **STB — Stop bit selector.** STB selects the number of stop bits used in transmission and reception.
- STB = 0 One stop bit is used in transmission and reception. This is the default value at reset.
- STB = 1 Two stop bits are used in transmission and reception.
- Bit 5** **CAD — Calibrate A detect bit.** CAD is used to enable and disable automatic baud-rate alignment (auto-baud alignment).
- CAD = 0 Disables auto-baud alignment.
- CAD = 1 Enables auto-baud alignment.
- Bit 4** **SETBRK — Set break bit.** Selects the output level of TX when the port is not transmitting.
- SETBRK = 0 The TX output is forced high when the port is not transmitting.
- SETBRK = 1 The TX output is forced low when the port is not transmitting.

- Bit 3** **CIO3 — Configuration bit for IO3.** CIO3 configures I/O pin 3 (IO3) as an input or as an output.
- CIO3 = 0 IO3 is configured as an input. This is the default value at reset.
- CIO3 = 1 IO3 is configured as an output.
- Bit 2** **CIO2 — Configuration bit for IO2.** CIO2 configures I/O pin 2 (IO2) as an input or as an output.
- CIO2 = 0 IO2 is configured as an input. This is the default value at reset.
- CIO2 = 1 IO2 is configured as an output.
- Bit 1** **CIO1 — Configuration bit for IO1.** CIO1 configures I/O pin 1 (IO1) as an input or as an output.
- CIO1 = 0 IO1 is configured as an input. This is the default value at reset.
- CIO1 = 1 IO1 is configured as an output.
- Bit 0** **CIO0 — Configuration bit for IO0.** CIO0 configures I/O pin 0 (IO0) as an input or as an output.
- CIO0 = 0 IO0 is configured as an input. This is the default value at reset.
- CIO0 = 1 IO0 is configured as an output.

10.3.2 I/O Status Register (IOSR)

The IOSR returns the status of the asynchronous serial port and of I/O pins IO0–IO3. The IOSR is a 16-bit, on-chip register mapped to address FFF6h in I/O space. Figure 10–4 shows the fields in the IOSR, and bit descriptions follow the figure.

Figure 10–4. I/O Status Register (IOSR) — I/O-Space Address FFF6h

15	14	13	12	11	10	9	8
Reserved	ADC	BI	TEMT	THRE	FE	OE	DR
0	R/W1C–0	R/W1C–0	R–1	R–1	R/W1C–0	R/W1C–0	R–0
7	6	5	4	3	2	1	0
DIO3	DIO2	DIO1	DIO0	IO3	IO2	IO1	IO0
R/W1C–x	R/W1C–x	R/W1C–x	R/W1C–x	R/W†–x	R/W†–x	R/W†–x	R/W†–x

Note: 0 = Always read as 0; R=Read access; W1C=Write 1 to this bit to clear it to 0; W = Write access; value following dash (–) is value after reset (x means value not affected by reset).

† This bit can be written to only when it is configured as an output by the corresponding CIO bit in the ASPCR.

Bit 15 **Reserved.** Always read as 0.

Bit 14 **ADC — A detect complete bit.** If the CAD bit of the ASPCR is 1 and the character *A* or *a* is received in the ADTR, ADC is set to 1. The character *A* or *a* remains in the ADTR after it has been detected. To avoid an overrun error when the next character arrives, the ADTR should be read immediately after ADC is set.

ADC = 0 *A* or *a* not has not been detected. No receive interrupt (TXRXINT) will be generated.

ADC = 1 *A* or *a* has been detected. If the CAD bit of the ASPCR is also 1, a receive interrupt (TXRXINT) will be generated, regardless of the values of the DIM, TIM, and RIM bits of the ASPCR. For as long as ADC = 1 and CAD = 1, a receive interrupt will occur.

Bit 13 **BI — Break interrupt indicator.** BI = 1 indicates that a break has been detected on the RX pin. Write a 1 to this bit to clear it to 0. BI is also cleared to 0 at reset.

A break on the RX pin also generates an interrupt (TXRXINT).

Bit 12 **TEMT — Transmit empty indicator.** TEMT = 1 indicates whether the transmit register (ADTR) and/or transmit shift register (AXSR) are full or empty. This bit is set to 1 on reset.

TEMT = 0 The ADTR and/or AXSR are full.

TEMT = 1 The ADTR and the AXSR are empty; the ADTR is ready for a new character to transmit.

- Bit 11** **THRE — Transmit register (ADTR) empty indicator.** THRE is set to 1 when the contents of the transmit register (ADTR) are transferred to the transmit shift register (AXSR). THRE is reset to 0 by the loading of the transmit register with a new character. A device reset sets THRE to 1.
- The emptying of the ADTR also generates an interrupt (TXRXINT).
- THRE = 0 The transmit register is not empty. Port operation is normal.
- THRE = 1 The transmit register is empty, indicating that it is ready to be loaded with a new character.
- Bit 10** **FE — Framing error indicator.** FE indicates whether a valid stop bit has been detected during reception. Clear the FE bit to 0 by writing a 1 to it. It is also cleared to 0 on reset.
- A framing error also generates an interrupt (TXRXINT).
- FE = 0 No framing error is detected. Port operation is normal.
- FE = 1 The character received did not have a valid (logic 1) stop bit.
- Bit 9** **OE — Receive register (ADTR) overrun indicator.** OE indicates whether an unread character has been overwritten. Clear the OE bit to 0 by writing a 1 to it. It is also cleared to 0 on reset.
- The occurrence of overrun also generates an interrupt (TXRXINT).
- OE = 0 No overrun error is detected. The port is operating normally.
- OE = 1 The last character in the ADTR was not read before the next character overwrote it.
- Bit 8** **DR — Data ready indicator for the receiver.** This bit indicates whether a new character has been received in the ADTR. This bit is automatically cleared to zero when the receive register (ADTR) is read or when the device is reset.
- The reception of a new character into the ADTR also generates an interrupt (TXRXINT).
- DR = 0 The receive register (ADTR) is empty.
- DR = 1 A character has been completely received and should be read from the receive register (ADTR).

Bit 7

DIO3 — Change detect bit for IO3. DIO3 indicates whether a change has occurred on the IO3 pin. A change can be detected only when IO3 is configured as an input by the CIO3 bit of the ASPCR (CIO3 = 0) and the serial port is enabled by the URST bit of the ASPCR (URST = 1). Writing a 1 to DIO3 clears it to 0.

The detection of a change on the IO3 pin also generates an interrupt (TXRXINT).

DIO3 = 0 No change is detected on IO3.

DIO3 = 1 A change is detected on IO3.

Bit 6

DIO2 — Change detect bit for IO2. DIO2 indicates whether a change has occurred on the IO2 pin. A change can be detected only when IO2 is configured as an input by the CIO2 bit of the ASPCR (CIO2 = 0) and the serial port is enabled by the URST bit of the ASPCR (URST = 1). Writing a 1 to DIO2 clears it to 0.

The detection of a change on the IO2 pin also generates an interrupt (TXRXINT).

DIO2 = 0 No change is detected on IO2.

DIO2 = 1 A change is detected on IO2.

Bit 5

DIO1 — Change detect bit for IO1. DIO1 indicates whether a change has occurred on the IO1 pin. A change can be detected only when IO1 is configured as an input by the CIO1 bit of the ASPCR (CIO1 = 0) and the serial port is enabled by the URST bit of the ASPCR (URST = 1). Writing a 1 to DIO1 clears it to 0.

The detection of a change on the IO1 pin also generates an interrupt (TXRXINT).

DIO1 = 0 No change is detected on IO1.

DIO1 = 1 A change is detected on IO1.

Bit 4

DIO0 — Change detect bit for IO0. DIO0 indicates whether a change has occurred on the IO0 pin. A change can be detected only when IO0 is configured as an input by the CIO0 bit of the ASPCR (CIO0 = 0) and the serial port is enabled by the URST bit of the ASPCR (URST = 1). Writing a 1 to DIO0 clears it to 0.

The detection of a change on the IO0 pin also generates an interrupt (TXRXINT).

DIO0 = 0 No change is detected on IO0.

DIO0 = 1 A change is detected on IO0.

Bit 3	IO3 — Status bit for IO3. When the IO3 pin is configured as an input (by the CIO3 bit of the ASPCR), this bit reflects the current level on the IO3 pin. IO3 = 0 The IO3 signal is low. IO3 = 1 The IO3 signal is high.
Bit 2	IO2 — Status bit for IO2. When the IO2 pin is configured as an input (by the CIO2 bit of the ASPCR), this bit reflects the current level on the IO2 pin. IO2 = 0 The IO2 signal is low. IO2 = 1 The IO2 signal is high.
Bit 1	IO1 — Status bit for IO1. When the IO1 pin is configured as an input (by the CIO1 bit of the ASPCR), this bit reflects the current level on the IO1 pin. IO1 = 0 The IO1 signal is low. IO1 = 1 The IO1 signal is high.
Bit 0	IO0 — Status bit for IO0. When the IO0 pin is configured as an input (by the CIO0 bit of the ASPCR), this bit reflects the current level on the IO0 pin. IO0 = 0 The IO0 signal is low. IO0 = 1 The IO0 signal is high.

10.3.3 Baud-Rate Divisor Register (BRD)

The baud rate of the asynchronous serial port can be set to many different rates by means of the BRD, an on-chip register located at address FFF7h in I/O space. Equation 10–1 shows how to set the BRD value to get the desired baud rate. When the BRD contains 0, the ASP will not transmit or receive any character. At reset, BRD = 0001h.

Equation 10–1. Value Needed in the BRD

$$\text{BRD value in decimal} = \frac{\text{CLKOUT1 frequency}}{16 \times \text{desired baud rate}}$$

Table 10–2 lists common baud rates and the corresponding hexadecimal value that should be in the BRD for a given CLKOUT1 frequency.

Table 10–2. Common Baud Rates and the Corresponding BRD Values

Baud Rate	BRD Value in Hexadecimal		
	CLKOUT1 = 20 MHz (50 ns)	CLKOUT1 = 28.57 MHz (35 ns)	CLKOUT1 = 40 MHz (25 ns)
1200	0411	05CC	0823
2400	0208	02E6	0411
4800	0104	0173	0208
9600	0082	00B9	0104
19200	0041	005C	0082

10.3.4 Using Automatic Baud-Rate Detection

The ASP contains auto-baud detection logic, which allows the ASP to lock to the incoming data rate. The following steps explain the sequence by which the detection logic could be implemented:

- 1) Enable auto-baud detection by setting the CAD bit in the ASPCR to 1 and ADC bit in the IOSR to zero.
- 2) Receive from a host the ASCII character *A* or *a* as the first character, at any desired baud rate definable in the BRD register. If the first character received is *A* or *a*, the serial port will lock to the incoming baud rate (the rate of the host), and the BRD register will be updated to the incoming baud rate value.
- 3) Baud-rate detection is indicated by a TXRXINT interrupt (mapped to vector location 000Ch) if TXRXINT is unmasked in the interrupt mask register and is globally enabled by the INTM bit of status register ST0. This interrupt occurs regardless of the values of the DIM, TIM, and RIM bits in the ASPCR.
- 4) Following the baud detection interrupt, the ADTR should be read to clear the *A* or *a* character from the receive buffer. If the ADTR is not cleared, any subsequent character received will set the OE bit in the IOSR, indicating an overrun error.
- 5) Once the baud rate is detected, both the CAD and ADC bits must be cleared; write 0 to CAD and write 1 to ADC. If CAD is not cleared, the auto-baud-detection logic will try to lock to the incoming character speed. In addition, for as long as ADC = 1 and CAD = 1, receive interrupts will be generated.

10.3.5 Using I/O Pins IO3, IO2, IO1, and IO0

Pins IO3, IO2, IO1, and IO0 can be individually configured as inputs or outputs and can be used as handshake control for the asynchronous serial port or as general-purpose I/O pins. They are software-controlled through the asynchronous serial port control register (ASPCR) and the I/O status register (IOSR), as shown in Figure 10–5.

Figure 10–5. Example of the Logic for Pins IO0–IO3

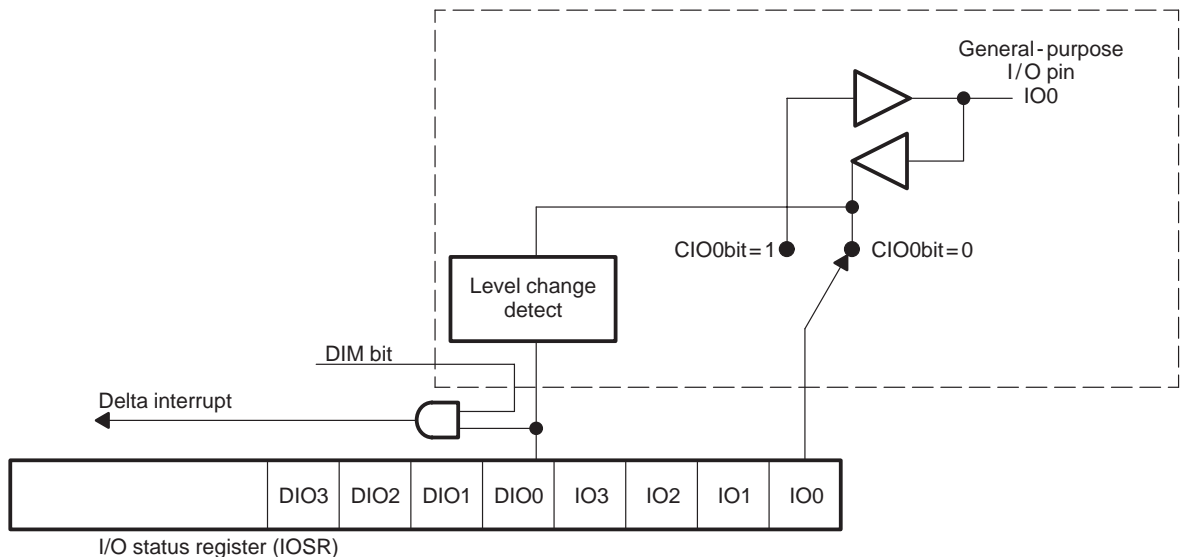

The four LSBs of the ASPCR, bits CIO0–CIO3, are for configuring each pin as an input or an output. For example, as shown in the figure, setting CIO0 to 1 configures IO0 as an output; setting CIO0 to 0 configures IO0 as an input. At reset, CIO0–CIO3 are all cleared to 0, making all four of the the pins inputs. Table 10–3 summarizes the configuration of the pins.

Table 10–3. Configuring Pins IO0–IO3 with ASPCR Bits CIO0–CIO3

CIO0 Bit	IO0 Pin	CIO1 Bit	IO1 Pin	CIO2 Bit	IO2 Pin	CIO3 Bit	IO3 Pin
0	Input	0	Input	0	Input	0	Input
1	Output	1	Output	1	Output	1	Output

When pins IO0–IO3 are configured as inputs

When pins IO0–IO3 are configured as inputs, the eight LSBs of the IOSR allow you to monitor these four pins. Each of the IOSR bits 3–0, called IO3, IO2, IO1, and IO0, can be used to read the current logic level (high or low) of the signal at the corresponding pin. Each of the bits 7–4, called DIO3, DIO2, DIO1, and DIO0, is used to track a change from a previous known or unknown signal value at the corresponding pin. When a change is detected on one of the pins, the corresponding detect bit is set to 1, and an interrupt request is sent to the CPU on the TXRXINT interrupt line. You can clear each of the detect bits to 0 by writing a 1 to it. DIO3–DIO0 are only useful when the pins are configured as inputs and the serial port is enabled by the URST bit of the ASPCR (URST = 1). Table 10–4 summarizes what IOSR bits 0–7 indicate when IO0–IO3 are inputs.

Table 10–4. Viewing the Status of Pins IO0–IO3 With IOSR Bits IO0–IO3 and DIO0–DIO3

IOSR Bit Number	IOSR Bit Name	When IO0–IO3 are inputs, this bit indicates...
0	IO0	Current logic level (0 or 1) on pin IO0
1	IO1	Current logic level (0 or 1) on pin IO1
2	IO2	Current logic level (0 or 1) on pin IO2
3	IO3	Current logic level (0 or 1) on pin IO3
4	DIO0†	Change detected (1) or not detected (0) on pin IO0 (when IO0 is an input)
5	DIO1†	Change detected (1) or not detected (0) on pin IO1 (when IO1 is an input)
6	DIO2†	Change detected (1) or not detected (0) on pin IO2 (when IO2 is an input)
7	DIO3†	Change detected (1) or not detected (0) on pin IO3 (when IO3 is an input)

† Write a 1 to this bit to clear it to 0.

When pins IO0–IO3 are configured as outputs

When pins IO0–IO3 are configured as outputs, you can write to the four LSBs (IO3–IO0) of the IOSR. The value you write to each bit becomes the new logic level at the corresponding pin. For example, if you write a 0 to bit 2, the logic level at pin IO2 changes to low; if you write a 1 to bit 2, the logic level on IO2 changes to high.

10.3.6 Using Interrupts

The asynchronous serial port interrupt (TXRXINT) can be generated by three types of interrupts:

- ❑ **Transmit interrupts.** A transmit interrupt is generated when the ADTR empties during transmission. This indicates that the port is ready to accept a new transmit character. In addition to generating the interrupt, the port sets the THRE bit of the IOSR to 1. Transmit interrupts can be disabled by the TIM bit of the ASPCR.

- ❑ **Receive interrupts.** Any one of the following events will generate a receive interrupt:
 - The ADTR holds a new character. This event is also indicated by the DR bit of the IOSR (DR = 1).
 - Overrun occurs. The last character in the ADTR was not read before the next character overwrote it. Overrun also sets the OE bit of the IOSR to 1.
 - A framing error occurs. The character received did not have a valid (logic 1) stop bit. This event is also indicated by the FE bit of the IOSR (FE = 1).
 - A break has been detected on the RX pin. This event also sets the BI bit of the IOSR to 1.
 - The character A or a has been detected in the ADTR by the auto-baud detect logic. This event also sets the ADC bit of the IOSR to 1. This interrupt will occur regardless of the values of the DIM, TIM, and RIM bits of the ASPCR.

With the exception of the A detect interrupt, receive interrupts can be disabled by the RIM bit of the ASPCR.

- ❑ **Delta interrupts.** This type of interrupt is generated if a change takes place on one of the I/O lines (IO0, IO1, IO2, or IO3) when the lines are used for ASP control (when DIM = 1 in the ASPCR). The event is also indicated by the corresponding detect bit (DIO0, DIO1, DIO2, or DIO3) in the IOSR. Delta interrupts can be disabled by the DIM bit of the ASPCR.

TXRXINT leads the CPU to interrupt vector location 000Ch in program memory. The branch at that location should lead to an interrupt service routine that identifies the cause of the interrupt and then acts accordingly. TXRXINT has a priority level of 9 (1 being highest).

TXRXINT is a maskable interrupt and is controlled by the interrupt mask register (IMR) and interrupt flag register (IFR).

Note:

To avoid a double interrupt from the ASP, clear the IFR bit (TXRXINT) in the corresponding interrupt service routine, just before returning from the routine.

10.4 Transmitter Operation

The transmitter consists of an 8-bit transmit register (ADTR) and an 8-bit transmit shift register (AXSR). Data to be transmitted is written to the ADTR, and then the port transfers the data to the AXSR. Data written to the transmit register should be written in right-justified form, with the LSB as the rightmost bit. Data from the AXSR is shifted out on the TX pin in the serial form shown in Figure 10–6 (the number of stop bits depends on the value of the STB bit in the ASPCR). When the serial port is not transmitting, TX should be held high by clearing the SETBRK bit of the ASPCR (SETBRK = 0).

Figure 10–6. Data Transmit



Transmission is started by a write to the ADTR. If the AXSR is empty, data from the ADTR is transferred to the AXSR. If the AXSR is full, then data is kept in the ADTR, and existing data in the AXSR is shifted out to the sequence control logic. If both the AXSR and ADTR are full and the CPU tries to write to the ADTR, the write is not allowed, and existing data in both registers is maintained.

If the transmit register is empty and interrupt TXRXINT is unmasked (in the IMR) and enabled (by the INTM bit), an interrupt is generated. When the ADTR empties, the THRE bit of the IOSR is set to 1. The bit is cleared when a character is loaded into the transmit register. Bit 12 (TEMT) of the IOSR is set if both the transmit and transmit shift registers are empty.

The sequence control logic constructs the transmit frame by sending out a start bit followed by the data bits from the AXSR and either one or two stop bits.

Here is a summary of asynchronous mode transmission:

- 1) An interrupt (TXRXINT) is generated if the transmit register is empty.
- 2) If AXSR is empty, the data is transferred from ADTR to AXSR.
- 3) A start bit is transmitted to TX, followed by eight data bits (LSB first), and the stop bit(s).
- 4) For the next transmission, the process begins again from step 1.

To avoid double interrupts, the interrupt service routine should clear TXRXINT in the interrupt flag register (IFR), just before forcing a return from the routine. Take special care when using this interrupt; it will be generated frequently for as long as the transmit register is empty.

10.5 Receiver Operation

The receiver includes two internal 8-bit registers: the receive register (ADTR) and receive shift register (ARSR). The data received at the RX pin should have the serial form shown in Figure 10–7 (the number of stop bits required depends on the value of the STB bit in the ASPCR).

Figure 10–7. Data Receive

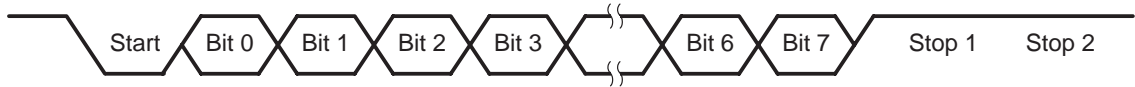

Data is received on the RX pin, and the negative-edge detect logic initiates a receive operation and checks for a start bit. After the eight data bits are received, a stop bit (or bits) should be received, indicating the end of that block. If a valid stop bit is not received, a framing error has occurred; in response, the FE bit in the ASPCR is set to 1, and a TXRXINT interrupt is generated. Then normal reception continues, and the receiver looks for the next start bit.

Once a valid stop bit is received, data is then transferred to the ADTR, and an interrupt (TXRXINT) is sent to the CPU. The DR bit of the IOSR is set to indicate that a character has been received in the receive register, ADTR. (DR is cleared to 0 when the ADTR is read.) The ARSR is now available to receive another character.

If ADTR is not read before new data is transferred into the ADTR, the overflow error (OE) flag is set in the IOSR.

In summary, asynchronous mode reception involves the following events:

- 1) A negative edge is received on RX to indicate a start bit. A test is performed to indicate whether a start bit is valid.
- 2) If the start bit is valid, eight data bits are shifted into ARSR (LSB first).
- 3) A stop bit is received to indicate end of reception. (If a stop bit is not received, a framing error is indicated.)
- 4) Data is transferred from ARSR to ADTR.
- 5) An interrupt is sent to the CPU once data has been placed in the ADTR.
- 6) Reception is complete. The receiver waits for another negative transition.

To avoid double interrupts, the interrupt service routine should clear TXRXINT in the interrupt flag register (IFR) just before forcing a return from the routine.

TMS320C209

All 'C2xx devices use the same central processing unit (CPU), bus structure, and instruction set, but the 'C209 has some notable differences. This chapter compares features on the 'C209 with those on other 'C2xx devices and then provides information specific to the 'C209 in the areas of memory and I/O spaces, interrupts, and on-chip peripherals.

Topic	Page
11.1 'C209 Versus Other 'C2xx Devices	11-2
11.2 'C209 Memory and I/O Spaces	11-5
11.3 'C209 Interrupts	11-10
11.4 'C209 On-Chip Peripherals	11-14

11.1 'C209 Versus Other 'C2xx Devices

This section explains the differences between the 'C209 and other 'C2xx devices and concludes with a table to help you find the other information in this manual that applies to the 'C209.

11.1.1 What Is the Same

The following components and features are identical on all 'C2xx devices, including the 'C209:

- Central processing unit
- Status registers ST0 and ST1
- Assembly language instructions
- Addressing modes
- Global data memory
- Program-address generation logic
- General-purpose I/O pins $\overline{\text{BIO}}$ and XF

11.1.2 What Is Different

The important differences between the 'C209 and other 'C2xx devices are as follows:

- Peripherals:**
 - The 'C209 has no serial ports.
 - The wait-state generator can be programmed to generate either no wait states or one wait state. Other 'C2xx devices provide zero to seven wait states.
 - The wait-state generator does not provide separate wait states for the upper and lower halves of program memory.
 - The 'C209 supports address visibility mode (enabled with the wait-state generator control register). In this mode, the device passes the internal program address to the external address bus when this bus is not used for an external access.
 - The 'C209 clock generator supports only two options: multiply-by-two ($\times 2$) and divide-by-two ($\div 2$).
 - The 'C209 does not have a CLK register; thus it cannot prevent the CLKOUT1 signal from appearing on the CLKOUT1 pin.
 - The 'C209 does not have I/O pins IO3, IO2, IO1, and IO0.

□ **Memory and I/O Spaces:**

- The I/O addresses of the peripheral registers are different on the 'C209.
- The 'C209 does not support the 'C2xx HOLD operation.

□ **Interrupts:**

- The 'C209 has four maskable interrupt lines, none of them shared. The other devices have six interrupt lines, one shared by the $\overline{\text{INT2}}$ and $\overline{\text{INT3}}$ pins.
- The 'C209 does not have an interrupt control register (ICR) because $\overline{\text{INT2}}$ and $\overline{\text{INT3}}$ have their own interrupt lines.
- Although the interrupt flag register (IFR) and interrupt mask register (IMR) are used in the same way on all 'C2xx device, the 'C209 has fewer flag and mask bits because it does not have serial ports.
- On the 'C209, interrupts $\overline{\text{INT2}}$ and $\overline{\text{INT3}}$ have their own interrupt lines and, thus, have their own interrupt vectors. On other 'C2xx devices, $\overline{\text{INT2}}$ and $\overline{\text{INT3}}$ share an interrupt line and, thus, share one interrupt vector.
- The 'C209 has an interrupt acknowledge pin ($\overline{\text{IACK}}$), which allows external detection of when an interrupt has been acknowledged.
- The 'C209 has two pins for reset: $\overline{\text{RS}}$ and RS; other 'C2xx devices have only $\overline{\text{RS}}$.

11.1.3 Where to Find the Information You Need About the TMS320C209

For information about:		Look here:
Assembly language instructions		Chapter 7, <i>Assembly Language Instructions</i>
Clock generator	Main description	Chapter 8, <i>On-Chip Peripherals</i>
	Options and configuration	Subsection 11.4.1 (page 11-14)
CPU		Chapter 3, <i>Central Processing Unit</i>
Data-address generation		Chapter 6, <i>Addressing Modes</i>
I/O Space	Main description	Chapter 4, <i>Memory</i>
	Effect of READY pin	Section 11.2 (page 11-5)
	Control register locations	Table 11–3 (page 11-9)

For information about:		Look here:
Interrupts	Main description	Chapter 5, <i>Program Control</i>
	Vector locations	Table 11-4 (page 11-10)
	Flag and mask registers	Subsection 11.3.1 (page 11-11)
	Interrupt acknowledge pin	Subsection 11.3.2 (page 11-13)
Memory	Main description	Chapter 4, <i>Memory</i>
	Address maps	Figure 11-1 (page 11-6)
	Configuration	Section 11.2 (page 11-5)
Pipeline		Chapter 5, <i>Program Control</i>
Power-down mode		Chapter 5, <i>Program Control</i>
Program-address generation		Chapter 5, <i>Program Control</i>
Program control		Chapter 5, <i>Program Control</i>
Stack		Chapter 5, <i>Program Control</i>
Status registers		Chapter 5, <i>Program Control</i>
Timer	Main description	Chapter 8, <i>On-Chip Peripherals</i>
	Configuration	Subsection 11.4.2 (page 11-15)
Wait-state generator	Main description	Chapter 8, <i>On-Chip Peripherals</i>
	Configuration	Subsection 11.4.3 (page 11-16)

11.2 'C209 Memory and I/O Spaces

The 'C209 does not have an on-chip boot loader and does not support the 'C2xx HOLD operation. Figure 11–1 shows the 'C209 address map. The on-chip program and data memory available on the 'C209 consists of:

- ROM (4K words, for program memory)
- SARAM (4K words, for program and/or data memory)
- DARAM B0 (256 words, for program or data memory)
- DARAM B1 (256 words, for data memory)
- DARAM B2 (32 words, for data memory)

Figure 11–1. 'C209 Address Maps

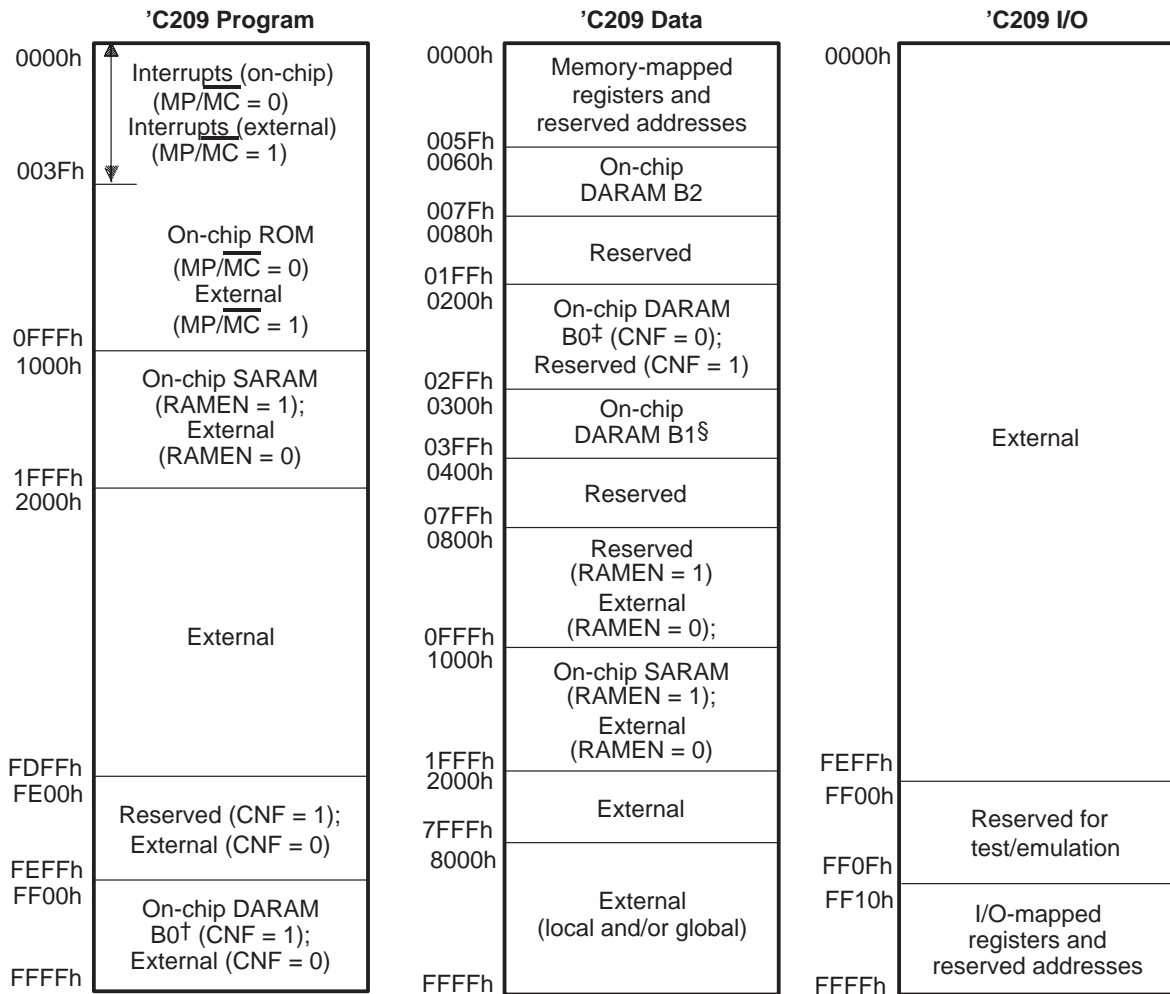

[†] When CNF = 1, addresses FE00h–FEFFh and FF00h–FFFFh are mapped to the same physical block (B0) in program-memory space. For example, a write to FE00h will have the same effect as a write to FF00h. For simplicity, addresses FE00h–FEFFh are referred to here as reserved when CNF = 1.

[‡] When CNF = 0, addresses 0100h–01FFh and 0200h–02FFh are mapped to the same physical block (B0) in data-memory space. For example, a write to 0100h will have the same effect as a write to 0200h. For simplicity, addresses 0100h–01FFh are referred to here as reserved.

[§] Addresses 0300h–03FFh and 0400h–04FFh are mapped to the same physical block (B1) in data-memory space. For example, a write to 0400h has the same effect as a write to 0300h. For simplicity, addresses 0400h–04FFh are referred to here as reserved.

Do Not Write to Reserved Addresses

To avoid unpredictable operation of the processor, do not write to any addresses labeled Reserved. This includes any data-memory address in the range 0000h–005Fh that is not designated for an on-chip register and any I/O address in the range FF00h–FFFFh that is not designated for an on-chip register.

You select or deselect the ROM by changing the level on the MP/\overline{MC} pin at reset:

- When **$MP/\overline{MC} = 0$ (low) at reset**, the device is configured as a microcomputer. The on-chip ROM is enabled and is accessible at addresses 0000h–0FFFh. The device fetches the reset vector from on-chip ROM.
- When **$MP/\overline{MC} = 1$ (high) at reset**, the device is configured as a microprocessor, and addresses 0000h–0FFFh are used to access external memory. The device fetches the reset vector from external memory.

Regardless of the value of MP/\overline{MC} , the 'C2xx fetches its reset vector at location 0000h of program memory.

The addresses assigned to the on-chip SARAM are shared by program memory and data memory. The RAMEN signal allows you to toggle the data addresses 1000h–1FFFh and the program addresses 1000h–1FFFh between on-chip memory and external memory:

- When **RAMEN = 1 (high)**, program addresses 1000h–1FFFh and data addresses 1000h–1FFFh are mapped to the same physical locations in the on-chip SARAM. For example, 1000h in program memory and 1000h in data memory point to the same physical location in the on-chip SARAM. Thus, the 4K words of on-chip SARAM are accessible for program and/or data space.

Note:

When RAMEN = 1, program addresses 1000h–1FFFh and data addresses 1000h–1FFFh are one and the same. When writing data to these locations be careful not to overwrite existing program instructions.

- When **RAMEN = 0 (low)**, program addresses 1000h–1FFFh (4K) are mapped to external program memory and data addresses 1000h–1FFFh

(4K) are mapped to external data memory. Thus, a total of 8K additional addresses (4K program and 4K data) are available for external memory.

DARAM blocks B1 and B2 are fixed, but DARAM block B0 may be mapped to program space or data space, depending on the value of the CNF bit (bit 12 of status register ST1):

- When **CNF = 0**, B0 is mapped to data space and is accessible at data addresses 0200h–02FFh. Note that the addressable external *program* memory increases by 512 words. At reset, CNF = 0.
- When **CNF = 1**, B0 is mapped to program space and is accessible at program addresses FF00h–FFFFh.

Table 11–1 lists the available program memory configurations for the 'C209; Table 11–2 lists the data-memory configurations. Note these facts:

- Program-memory addresses 0000h–003Fh are used for the interrupt vectors.
- Data-memory addresses 0000h–005Fh contain on-chip memory-mapped registers and reserved memory.
- Two other on-chip data-memory ranges are always reserved: 0080h–01FFh and 0400h–07FFh.

Table 11–1. 'C209 Program-Memory Configuration Options

MP/ $\overline{\text{MC}}$	RAMEN	CNF	ROM (hex)	SARAM (hex)	DARAM B0 (hex)	External (hex)	Reserved (hex)
0	0	0	0000–0FFF	–	–	1000–FFFF	–
0	0	1	0000–0FFF	–	FF00–FFFF	1000–FDFF	FE00–FEFF
0	1	0	0000–0FFF	1000–1FFF	–	2000–FFFF	–
0	1	1	0000–0FFF	1000–1FFF	FF00–FFFF	2000–FDFF	FE00–FEFF
1	0	0	–	–	–	0000–FFFF	–
1	0	1	–	–	FF00–FFFF	0000–FDFF	FE00–FEFF
1	1	0	–	1000–1FFF	–	0000–0FFF 2000–FFFF	–
1	1	1	–	1000–1FFF	FF00–FFFF	0000–0FFF 2000–FDFF	FE00–FEFF

Table 11–2. 'C209 Data-Memory Configuration Options

RAMEN	CNF	DARAM B0 (hex)	DARAM B1 (hex)	DARAM B2 (hex)	SARAM (hex)	External (hex)	Reserved (hex)
0	0	0200–02FF	0300–03FF	0060–007F	–	0800–FFFF	0000–005F 0080–01FF 0400–07FF
0	1	–	0300–03FF	0060–007F	–	0800–FFFF	0000–005F 0080–02FF 0400–07FF
1	0	0200–02FF	0300–03FF	0060–007F	1000–1FFF	2000–FFFF	0000–005F 0080–01FF 0400–0FFF
1	1	–	0300–03FF	0060–007F	1000–1FFF	2000–FFFF	0000–005F 0080–02FF 0400–0FFF

A portion of the on-chip I/O space contains the control registers listed in Table 11–3. The corresponding registers on other 'C2xx devices are not at the addresses shown in this table. When accessing the I/O-mapped registers on the 'C209, also keep in mind the following:

- The READY pin must be pulled high to permit reads from or writes to registers mapped to internal I/O space. This is not true for other 'C2xx devices.
- The \overline{IS} (I/O select) and R/\overline{W} (read/write) signals are visible on their pins during reads from or writes to registers mapped to internal I/O space. On other 'C2xx devices, none of the interface signals are visible during internal I/O accesses.

Table 11–3. 'C209 On-Chip Registers Mapped to I/O Space

I/O Address	Name	Description
FFFCh	TCR	Timer control register
FFFDh	PRD	Timer period register
FFFEh	TIM	Timer counter register
FFFFh	WSGR	Wait-state generator control register

Note: The corresponding registers on other 'C2xx devices are not at these addresses.

11.3 'C209 Interrupts

Table 11–4 lists the interrupts available on the 'C209 and shows their vector locations. In addition, it shows the priority of each of the hardware interrupts. Note that a device reset can be initiated in either of two ways: by driving the \overline{RS} pin low or by driving the RS pin high. The K value shown for each interrupt vector location is the operand to be used with the INTR instruction if you want to force a branch to that location.

Table 11–4. 'C209 Interrupt Locations and Priorities

K†	Vector Location	Name	Priority	Function
0	0h	\overline{RS} or RS‡	1 (highest)	Hardware reset (nonmaskable)
1	2h	$\overline{INT1}$	4	User-maskable interrupt #1
2	4h	$\overline{INT2}$	5	User-maskable interrupt #2
3	6h	$\overline{INT3}$	6	User-maskable interrupt #3
4	8h	TINT	7	User-maskable interrupt #4: timer interrupt
5	Ah		8	Reserved
6	Ch		9	Reserved
7	Eh		10	Reserved
8	10h	INT8	–	User-defined software interrupt
9	12h	INT9	–	User-defined software interrupt
10	14h	INT10	–	User-defined software interrupt
11	16h	INT11	–	User-defined software interrupt
12	18h	INT12	–	User-defined software interrupt
13	1Ah	INT13	–	User-defined software interrupt
14	1Ch	INT14	–	User-defined software interrupt

† The K value is the operand used in an INTR instruction that branches to the corresponding interrupt vector location.

‡ The 'C209 has two pins for triggering a hardware reset: \overline{RS} and RS. If either \overline{RS} is driven low or RS is driven high, the device will be reset.

Table 11–4. 'C209 Interrupt Locations and Priorities (Continued)

K†	Vector Location	Name	Priority	Function
15	1Eh	INT15	–	User-defined software interrupt
16	20h	INT16	–	User-defined software interrupt
17	22h	TRAP	–	TRAP instruction vector
18	24h	$\overline{\text{NMI}}$	3	Nonmaskable interrupt
19	26h		2	Reserved
20	28h	INT20	–	User-defined software interrupt
21	2Ah	INT21	–	User-defined software interrupt
22	2Ch	INT22	–	User-defined software interrupt
23	2Eh	INT23	–	User-defined software interrupt
24	30h	INT24	–	User-defined software interrupt
25	32h	INT25	–	User-defined software interrupt
26	34h	INT26	–	User-defined software interrupt
27	36h	INT27	–	User-defined software interrupt
28	38h	INT28	–	User-defined software interrupt
29	3Ah	INT29	–	User-defined software interrupt
30	3Ch	INT30	–	User-defined software interrupt
31	3Eh	INT31	–	User-defined software interrupt

† The K value is the operand used in an INTR instruction that branches to the corresponding interrupt vector location.

‡ The 'C209 has two pins for triggering a hardware reset: $\overline{\text{RS}}$ and RS. If either $\overline{\text{RS}}$ is driven low or RS is driven high, the device will be reset.

11.3.1 'C209 Interrupt Registers

As with other 'C2xx devices, the maskable interrupts of the 'C209 are controlled by an interrupt flag register (IFR) and an interrupt mask register (IMR). Figure 11–2 shows the IFR and Figure 11–3 shows the IMR. Each of the figures is followed by descriptions of the bits.

Figure 11–2. 'C209 Interrupt Flag Register (IFR) — Data-Memory Address 0006h

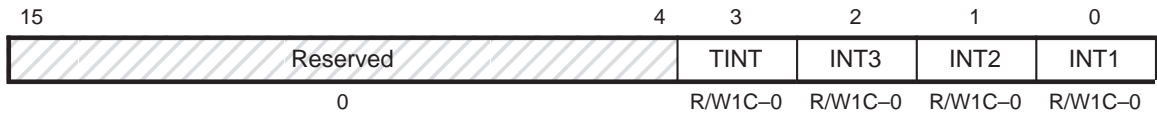

Note: 0 = Always read as zeros; R = Read access; W1C = Write 1 to this bit to clear it to 0; value following dash (–) is value after reset.

Bits 15–4 **Reserved.** Bits 15–4 are reserved and are always read as 0s.

Bit 3 **TINT — Timer interrupt flag.** Bit 3 indicates whether interrupt TINT is pending (whether TINT is requesting acknowledgment from the CPU).

TINT = 0 Interrupt TINT is not pending.

TINT = 1 Interrupt TINT is pending.

Bit 2 **INT3 — Interrupt 3 flag.** Bit 2 indicates whether $\overline{\text{INT3}}$ is pending (whether $\overline{\text{INT3}}$ is requesting acknowledgment from the CPU).

INT3 = 0 $\overline{\text{INT3}}$ is not pending.

INT3 = 1 $\overline{\text{INT3}}$ is pending.

Bit 1 **INT2 — Interrupt 2 flag.** Bit 1 indicates whether $\overline{\text{INT2}}$ is pending (whether $\overline{\text{INT2}}$ is requesting acknowledgment from the CPU).

INT2 = 0 $\overline{\text{INT2}}$ is not pending.

INT2 = 1 $\overline{\text{INT2}}$ is pending.

Bit 0 **INT1 — Interrupt 1 flag.** Bit 0 indicates whether $\overline{\text{INT1}}$ is pending (whether $\overline{\text{INT1}}$ is requesting acknowledgment from the CPU).

INT1 = 0 $\overline{\text{INT1}}$ is not pending.

INT1 = 1 $\overline{\text{INT1}}$ is pending.

Figure 11–3. 'C209 Interrupt Mask Register (IMR) — Data-Memory Address 0004h

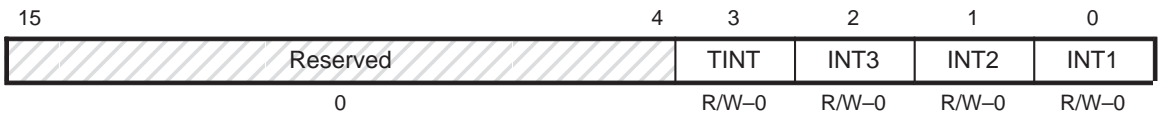

Note: Note: 0 = Always read as zeros; R = Read access; W = Write access; value following dash (–) is value after reset.

Bits 15–4 **Reserved.** Bits 15–4 are reserved and are always read as 0s.

Bit 3 **TINT — Timer interrupt mask.** Mask or unmask the internal timer interrupt, TINT, with this bit.

TINT = 0 TINT is unmasked.

TINT = 1 TINT is masked.

Bit 2 **INT3 — Interrupt 3 mask.** Unmask external interrupt $\overline{\text{INT3}}$ by writing a 1 to this bit.

INT3 = 0 $\overline{\text{INT3}}$ is unmasked.

INT3 = 1 $\overline{\text{INT3}}$ is masked.

Bit 1 **INT2 — Interrupt 2 mask.** Unmask external interrupt $\overline{\text{INT2}}$ by writing a 1 to this bit.

INT2 = 0 $\overline{\text{INT2}}$ is unmasked.

INT2 = 1 $\overline{\text{INT2}}$ is masked.

Bit 0 **INT1 — Interrupt 1 mask.** Unmask external interrupt $\overline{\text{INT1}}$ by writing a 1 to this bit.

INT1 = 0 $\overline{\text{INT1}}$ is unmasked.

INT1 = 1 $\overline{\text{INT1}}$ is masked.

11.3.2 $\overline{\text{IACK}}$ Pin

On the 'C209, the interrupt acknowledge signal is available at the external $\overline{\text{IACK}}$ pin. The CPU generates this signal while it fetches the first word of any of the interrupt vectors, whether the interrupt was requested by hardware or by software. $\overline{\text{IACK}}$ is not affected by wait states; $\overline{\text{IACK}}$ goes low only on the first cycle of the read when wait states are used. At reset, the interrupt acknowledge signal is generated in the same manner as for a maskable interrupt.

Your external hardware can use the $\overline{\text{IACK}}$ signal to determine when the processor acknowledges an interrupt. Additionally, when $\overline{\text{IACK}}$ goes low, the hardware can sample the address pins (A15–A0) to determine which interrupt the processor is acknowledging. Since the interrupt vectors are spaced apart by two words, address pins A1–A4 can be decoded at the falling edge of $\overline{\text{IACK}}$ to identify the interrupt being acknowledged.

11.4 'C209 On-Chip Peripherals

The 'C209 has these on-chip peripherals:

- Clock generator.** The clock generator is fundamentally the same on all 'C2xx devices, including the 'C209. However, the 'C209 is limited to the two clock modes described in subsection 11.4.1.
- Timer.** The timer is also fundamentally the same. The difference here is that the timer control register (TCR) on the 'C209 does not offer bits for configuring timer emulation modes. Subsection 11.4.2 describes the 'C209 TCR.
- Wait-state generator.** The wait-state generators of the 'C2xx devices operate similarly; however, the 'C209 wait-state generator is different from that of other 'C2xx devices in these ways:
 - It offers zero or one wait states (not zero to seven).
 - It cannot produce separate wait states for the lower (0000h–7FFFh) and upper (8000h–FFFFh) halves of program space.
 - It provides a bit for enabling or disabling address visibility mode. In this mode (not available on other 'C2xx devices), the 'C209 passes the internal program address to the external address bus when this bus is not used for an external access.

The 'C209 generator is programmable by way of the 'C209 wait-state generator control register (WSGR) and is described subsection 11.4.3.

11.4.1 'C209 Clock Generator Options

The 'C209 includes two clock modes: divide-by-2 ($\div 2$) and multiply-by-2 ($\times 2$). The $\div 2$ mode operates the CPU at half the input clock rate. The $\times 2$ option doubles the input clock and phase-locks the output clock with the input clock. To enable the $\div 2$ mode, tie the CLKMOD pin low. To enable the $\times 2$ mode, tie CLKMOD high. For each clock mode, Table 11–5 shows the generated CPU clock rate and shows the state of CLKMOD, the internal oscillator, and the internal phase lock loop (PLL).

Notes:

- Change CLKMOD only while the reset signal (\overline{RS} or RS) is active.
 - The PLL requires approximately 2200 cycles to lock the output clock signal to the input clock signal. When setting the $\times 2$ mode, keep the reset (\overline{RS} or RS) signal active until at least three cycles after the PLL has stabilized.
-

Table 11–5. 'C209 Input Clock Modes

Clock Mode	CLKOUT1 Rate	CLKMOD	Oscillator	PLL
÷ 2	CLKOUT1 = CLKIN ÷ 2	0	Enabled	Disabled
× 2	CLKOUT1 = CLKIN × 2	1	Disabled	Enabled

Remember the following points when configuring the clock mode:

- The modes cannot be configured dynamically. After you change the level on CLKMOD, the mode is not changed until a hardware reset is executed (\overline{RS} low or RS high).
- The clock doubler mode uses an internal phase-locked loop (PLL) that requires approximately 2200 cycles to lock. Delay the rising edge of \overline{RS} (or the falling edge of RS) until at least three cycles after the PLL has stabilized. When the PLL is used, the duty cycle of the CLKIN signal is more flexible, but the minimum duty cycle should not be less than 10 nanoseconds. When the PLL is not used, no phase-locking time is necessary, but the minimum pulse width must be 45% of the minimum clock cycle.

11.4.2 'C209 Timer Control Register (TCR)

Figure 11–4 shows the bit fields of the 'C209 TCR, and descriptions of the bit fields follow the figure.

Figure 11–4. 'C209 Timer Control Register (TCR) — I/O Address FFFCh

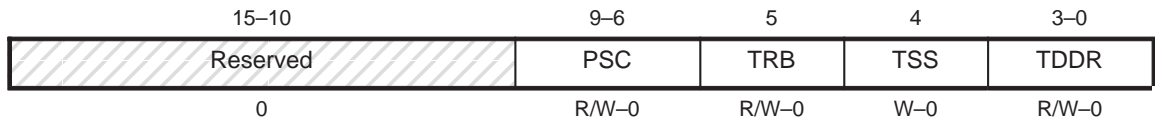

Note: Note: 0 = Always read as zeros; R = Read access; W = Write access; value following dash (–) is value after reset.

Bits 15–10 **Reserved.** TCR bits 10–15 are reserved and are always read as 0s.

Bits 9–6 **PSC — Timer prescaler counter.** These four bits hold the current prescale count for the timer. For every CLKOUT1 cycle that the PSC value is greater than 0, the PSC decrements by one. One CLKOUT1 cycle after the PSC reaches 0, the PSC is loaded with the contents of the TDDR, and the timer counter register (TIM) decrements by one. The PSC is also reloaded whenever the timer reload bit (TRB) is set by software. The PSC can be checked by reading the TCR, but it cannot be set directly. It must get its value from the timer divide-down register (TDDR). At reset, the PSC is set to 0.

Bit 5 **TRB — Timer reload bit.** When you write a 1 to TRB, the TIM is loaded with the value in the PRD, and the prescaler counter (PSC) is loaded with the value in the timer divide-down register (TDDR). The TRB bit is always read as zero.

Bit 4 **TSS — Timer stop status bit.** TSS is a 1-bit flag that stops or starts the timer. To stop the timer, set TSS to 1. To start or restart the timer, set TSS to 0. At reset, TSS is cleared to 0 and the timer immediately starts.

Bits 3–0 **TDDR — Timer divide-down register.** Every (TDDR + 1) CLKOUT1 cycles, the timer counter register (TIM) decrements by one. At reset, the TDDR bits are cleared to 0. If you want to increase the overall timer count by an integer factor, write this factor minus one to the four TDDR bits. When the prescaler counter (PSC) value is 0, one CLKOUT1 cycle later, the contents of the TDDR reload the PSC, and the TIM decrements by 1. TDDR also reloads the PSC whenever the timer reload bit (TRB) is set by software.

11.4.3 'C209 Wait-State Generator

As with other 'C2xx devices, the 'C209 offers two options for generating wait states:

- The READY signal.** With the READY signal, you can externally generate any number of wait states.
- The on-chip wait-state generator.** With the 'C209 wait-state generator, you can internally generate zero or one wait state.

The 'C209 wait-state generator inserts a wait state to a given memory space (data, program, or I/O) if the corresponding bit in WSGR is set to 1, regardless of the condition of the READY signal. As with other 'C2xx devices, the READY signal can then be used to further extend wait states. The WSGR control bits are all set to 1 by reset, so that the device can operate from slow memory after reset. To avoid bus conflicts, writes from the 'C209 always take two CLKOUT1 cycles each.

To control the wait-state generator, you read from or write to the wait-state generator control register (WSGR), mapped to I/O memory location FFFh. Figure 11–5 shows the register's bit layout, and descriptions of the bits follow. The WSGR also enables or disables address visibility mode.

Figure 11–5. 'C209 Wait-State Generator Control Register (WSGR) — I/O Address FFFFh

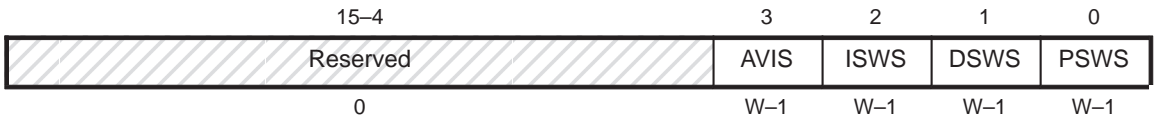

Note: 0 = Always read as zeros; W = Write access; value following dash (–) is value after reset.

- Bits 15–4** **Reserved.** Bits 15–4 are reserved and are always read as 0s.
- Bit 3** **AVIS — Address visibility mode.** AVIS = 1 enables the address visibility mode of the device. In this mode, the device provides a method of tracing internal code operation: it passes the internal program address to the address bus when this bus is not used for an external access. At reset, AVIS is set to 1. For production systems, the AVIS bit should be cleared to 0 to reduce power and noise. (AVIS does not generate a wait state.)
- Bit 2** **ISWS — I/O-space wait-state bit.** When ISWS = 1, one wait state will be applied to all reads from off-chip I/O space. When ISWS = 0, no wait states are generated for off-chip I/O space. At reset, this bit is set to 1.
- Bit 1** **DSWS — Data-space wait-state bit.** When DSWS = 1, one wait state will be applied to all reads from off-chip data space. When DSWS = 0, no wait states are generated for off-chip data space. At reset, this bit is set to 1.
- Bit 0** **PSWS — Program-space wait-state bit.** When PSWS = 1, one wait state will be applied to all reads from off-chip program space. When PSWS = 0, no wait states are generated for off-chip program space. At reset, this bit is set to 1.

Register Summary

For the status and control registers of the 'C2xx devices, this appendix summarizes:

- Their addresses
- Their reset values
- The functions of their bits

Topic	Page
A.1 Addresses and Reset Values	A-2
A.2 Register Descriptions	A-4

A.1 Addresses and Reset Values

The following tables list the 'C2xx registers, the addresses at which they can be accessed, and their reset values. Note that the registers mapped to internal I/O space on the 'C209 are at addresses different from those of other 'C2xx devices. In addition, the 'C209 wait-state generator control register has a different reset value because there are only four control bits in the register.

Table A–1. Reset Values of the Status Registers

Name	Reset Value (Binary)	Description
ST0	XXX0 X11X XXXX XXXX	Status register 0
ST1	XXX0 X111 1111 1100	Status register 1

- Notes:**
- 1) No addresses are given for ST0 and ST1 because they can be accessed only by the CLRC, SETC, LST, and SST instructions.
 - 2) X: Reset does not affect these bits.

Table A–2. Addresses and Reset Values of On-Chip Registers Mapped to Data Space

Name	Data-Memory Address	Reset Value	Description
IMR	0004h	0000h	Interrupt mask register
GREG	0005h	0000h	Interrupt control register
IFR	0006h	0000h	Synchronous data transmit and receive register

Note: An x in an address represents four bits that are either not affected by reset or dependent on pin levels at reset.

Table A–3. Addresses and Reset Values of On-Chip Registers Mapped to I/O Space

Name	I/O Address		Reset Value	Description
	'C209	Other 'C2xx		
CLK	–	FFE8h	0000h	CLKOUT1-pin control (CLK) register
ICR	–	FFEC	0000h	Interrupt control register
SDTR	–	FFF0h	xxxxh	Synchronous data transmit and receive register
SSPCR	–	FFF1h	0030h	Synchronous serial port control register
ADTR	–	FFF4h	xxxxh	Asynchronous data transmit and receive register
ASPCR	–	FFF5h	0000h	Asynchronous serial port control register

Note: An x in an address represents four bits that are either not affected by reset or dependent on pin levels at reset.

Table A–3. Addresses and Reset Values of On-Chip Registers Mapped to I/O Space (Continued)

Name	I/O Address		Reset Value	Description
	'C209	Other 'C2xx		
IOSR	–	FFF6h	18xxh	I/O status register
BRD	–	FFF7h	0001h	Baud-rate divisor register
TCR	FFFCh	FFF8h	0000h	Timer control register
PRD	FFFDh	FFF9h	FFFFh	Timer period register
TIM	FFFEh	FFFAh	FFFFh	Timer counter register
WSGR	FFFFh	FFFC	0FFFh	Wait-state generator control register

Note: An x in an address represents four bits that are either not affected by reset or dependent on pin levels at reset.

A.2 Register Descriptions

The following figures summarize the content of the 'C2xx status and control registers that are divided into fields. (The other registers contain no control bits; they simply hold a single 16-bit value.) Each figure in this section provides information in this way:

- The value shown in the register is the value after reset. If the value of a particular bit is not affected by reset or depends on pin levels at reset, that bit will contain an X.
- Each unreserved bit field or set of bits has a callout that very briefly describes its effect on the processor.
- Each non-reserved bit field or set of bits is labeled with one or more of the following symbols:
 - R indicates that your software can read the bit field but cannot write to it.
 - W indicates that your software can read the bit field and write to it.
 - W1C indicates that writing a 1 to the bit field clears it to 0; writing a 0 has no effect.

When both read access and write access apply to a bit field, two of these symbols are shown, separated by / (a forward slash): R/W or R/W1C.

- Where needed, footnotes provide additional information for a particular figure.

Status Register ST0

15	14	13	12	11	10	9	8	7	6	5	4	3	2	1	0
X	X	X	0	X	1†	1	X	X	X	X	X	X	X	X	X
ARP			OV		OVM	INTM				DP					

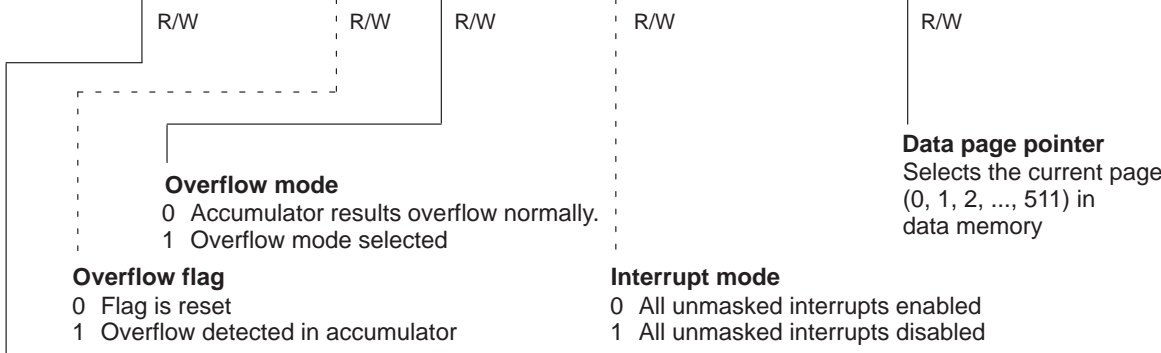

Auxiliary register pointer
 Selects the current auxiliary register (0, 1, 2, 3, 4, 5, 6, or 7)

† This reserved bit is always read as 1. Writes have no effect.

Status Register ST1

15	14	13	12	11	10	9	8	7	6	5	4	3	2	1	0
X	X	X	0	X	1	1	1†	1†	1†	1†	1	1†	1†	0	0
ARB			CNF		TC	SXM		C			XF			PM	

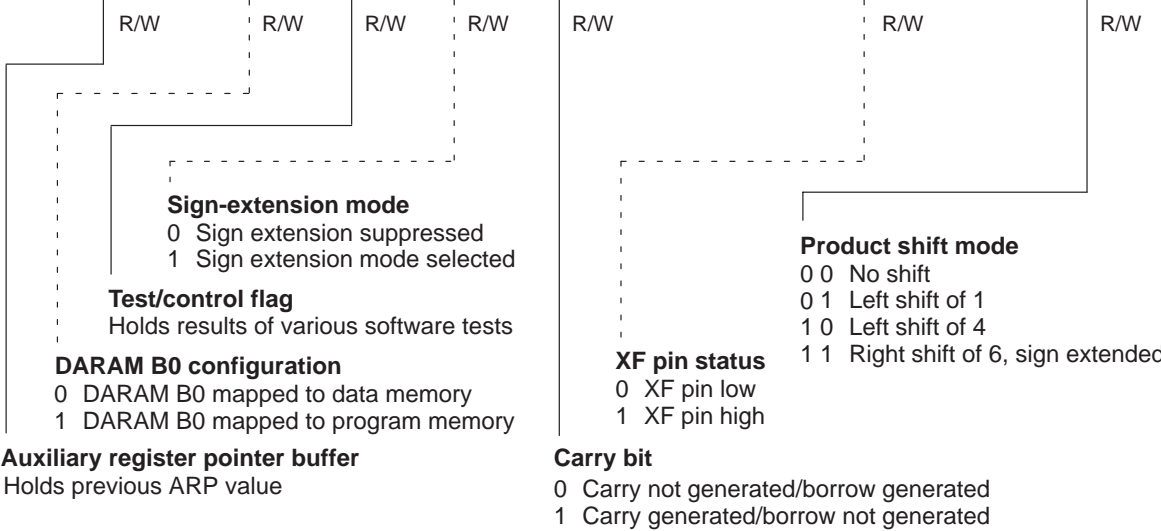

† These reserved bits are always read as 1s. Writes have no effect.

'C2xx Interrupt Flag Register (IFR) — Except 'C209 — Data-Memory Address 0006h

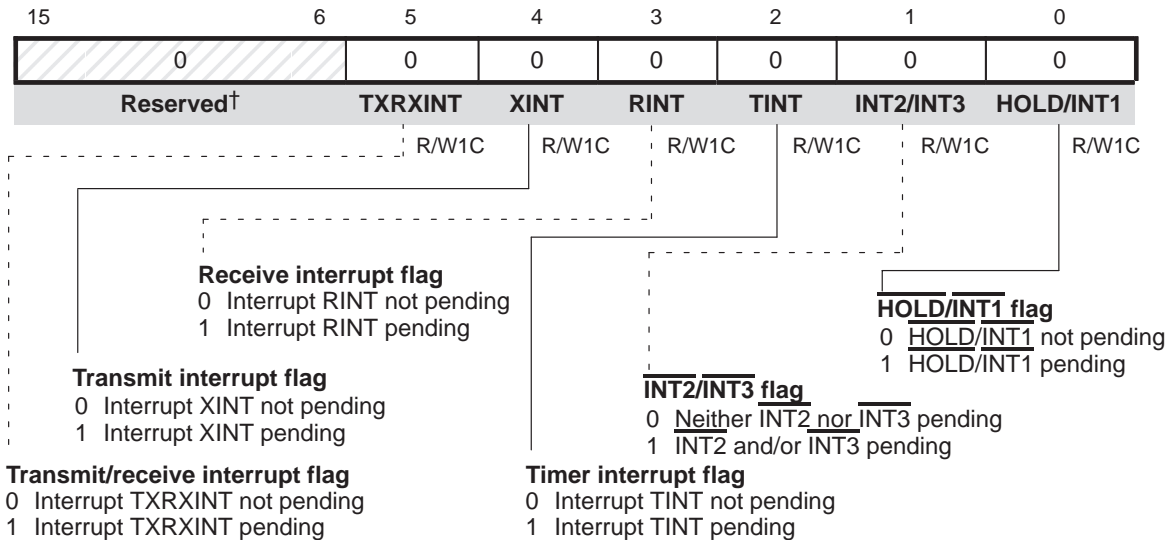

† These reserved bits are always read as 0s. Writes have no effect.

Interrupt Flag Register (IFR) — 'C209 — Data-Memory Address 0006h

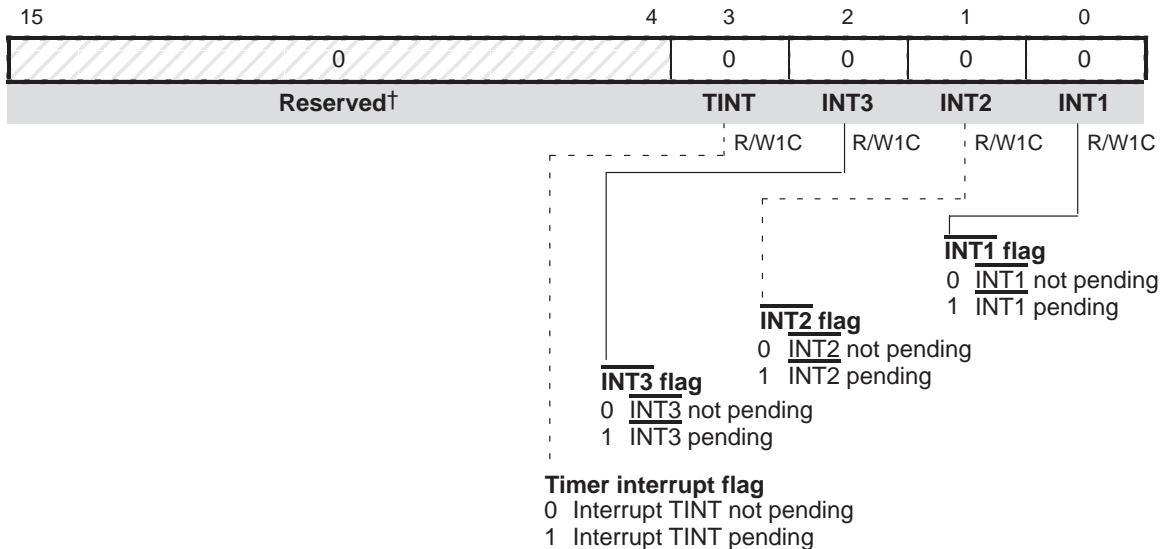

† These reserved bits are always read as 0s. Writes have no effect.

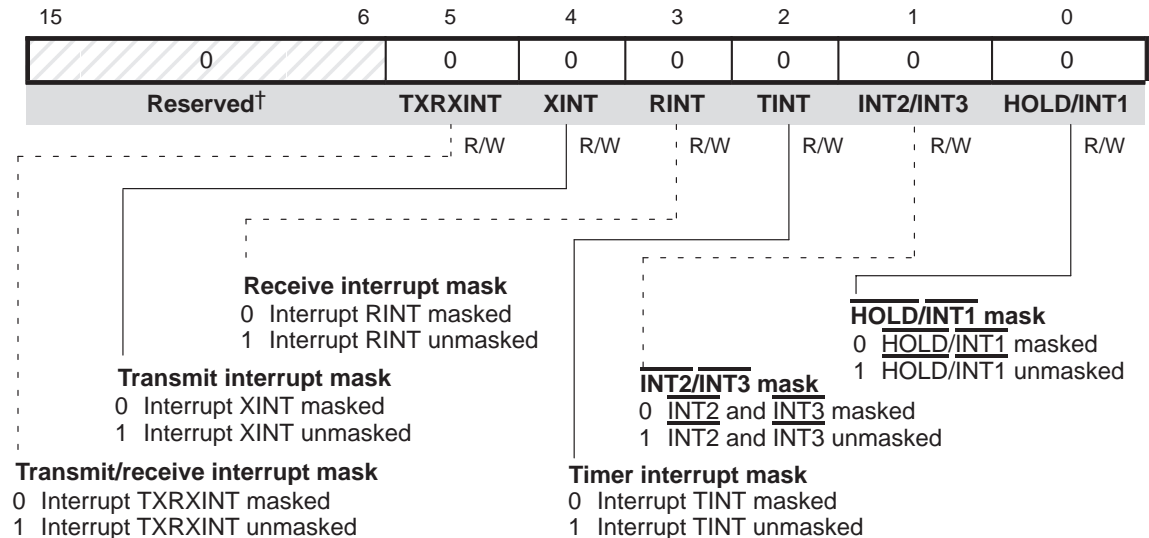
Interrupt Mask Register (IMR) — Except 'C209 — Data-Memory Address 0004h

† These reserved bits are always read as 0s. Writes have no effect.

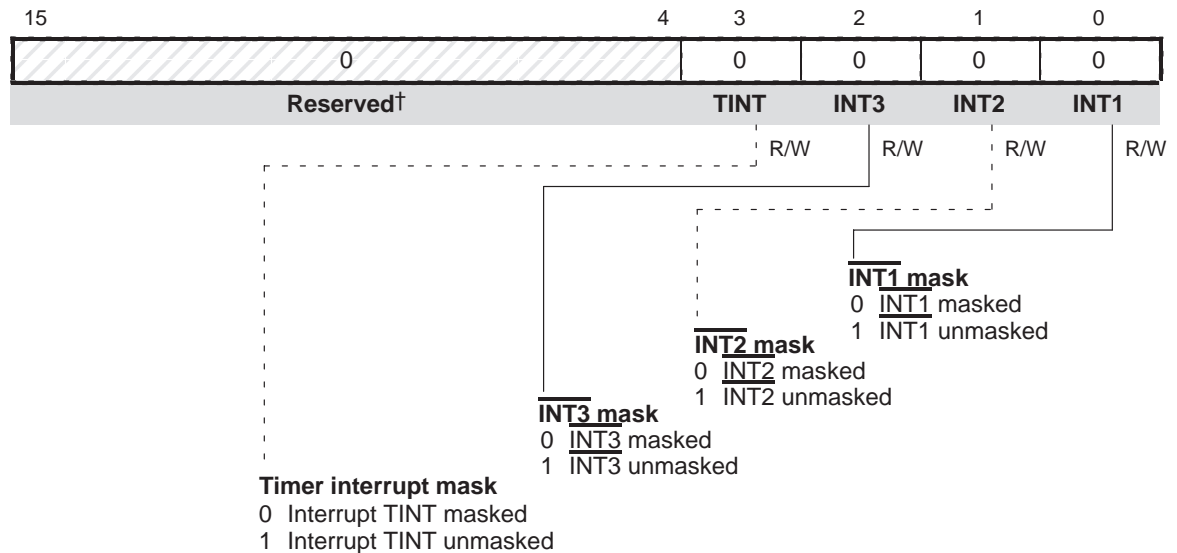
Interrupt Mask Register (IMR) — 'C209 — Data-Memory Address 0004h

† These reserved bits are always read as 0s. Writes have no effect.

Interrupt Control Register (ICR) — I/O Address FFECh

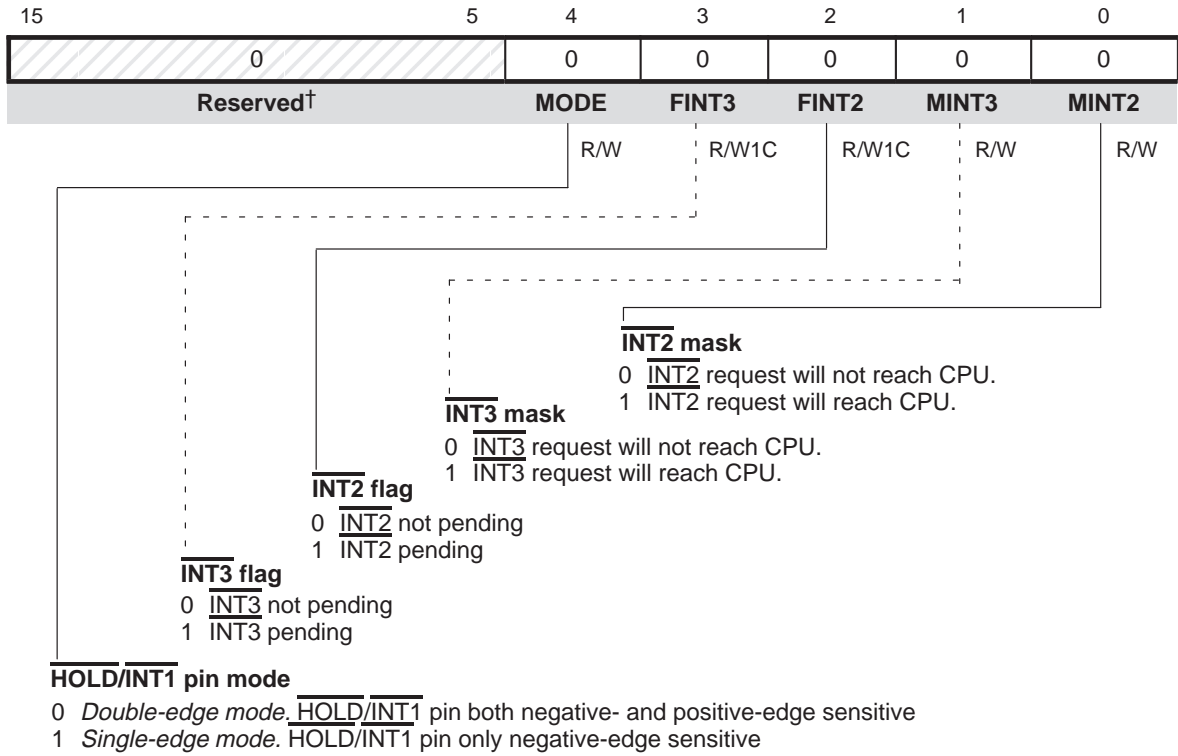

† These reserved bits are always read as 0s. Writes have no effect.

Wait-State Generator Control Register (WSGR) — Except 'C209— I/O Address FFFCh

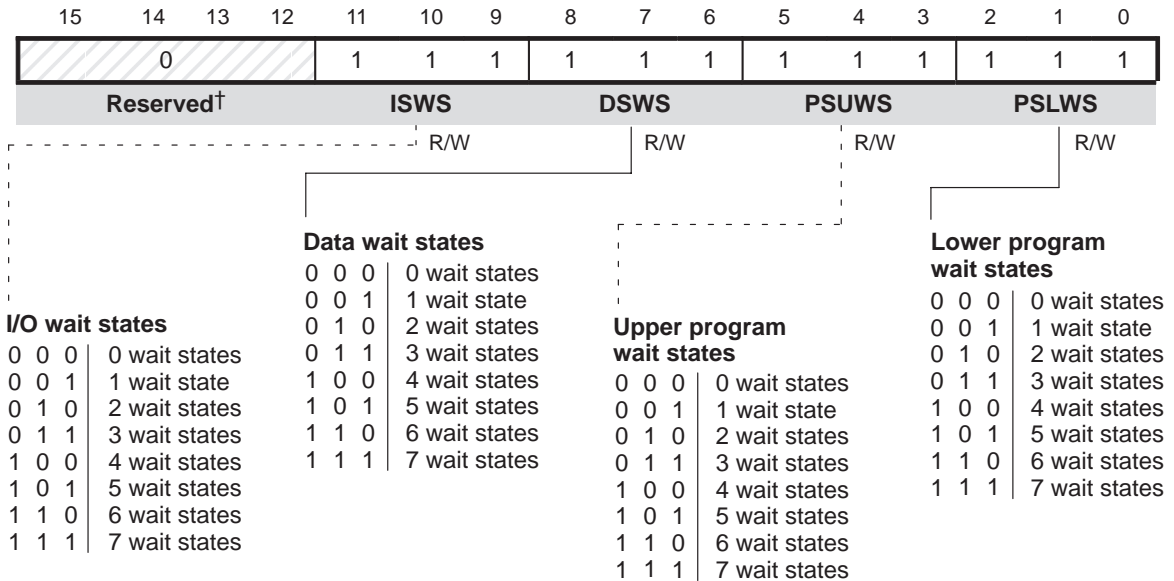

† These reserved bits are always read as 0s. Writes have no effect.

Wait-State Generator Control Register (WSGR) — 'C209 — I/O Address FFFFh

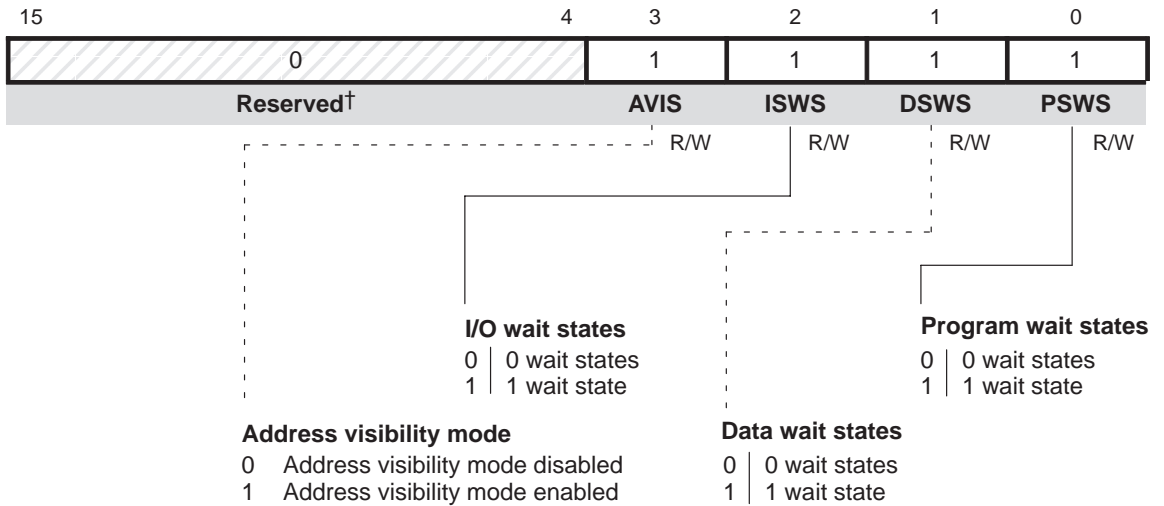

† These reserved bits are always read as 0s. Writes have no effect.

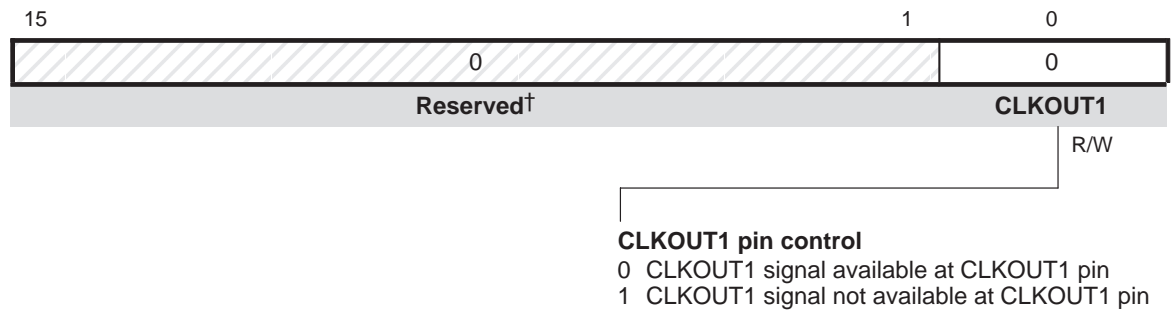
CLK Register — I/O Address FFE8h

† These reserved bits are always read as 0s. Writes have no effect.

Synchronous Serial Port Control Register (SSPCR) — I/O Address FFF1h

15	14	13	12	11	10	9	8
0	0	0	0	0	0	0	0

FREE		SOFT		TCOMP	RFNE	FT1	FT0	FR1	FR0
R/W		R/W		R	R	R/W	R/W	R/W	R/W

Receive FIFO buffer status

- 0 Receive buffer empty.
- 1 Receive buffer holds data.

Transmit FIFO buffer status

- 0 Transmit buffer empty.
- 1 Transmit buffer not empty.

Generate RINT when . . .

- 0 0 Receive buffer not empty.
- 0 1 Receive buffer holds 2 or more words.
- 1 0 Receive buffer holds 3 or 4 words.
- 1 1 Receive buffer full.

Emulation/run mode

- 0 0 Immediate stop
- 0 1 Stop after completion of word
- 1 0 Free run
- 1 1 Free run

Generate XINT when . . .

- 0 0 Transmit buffer can accept 1 or more words.
- 0 1 Transmit buffer can accept 2 or more words.
- 1 0 Transmit buffer can accept 3 or 4 words.
- 1 1 Transmit buffer empty (can accept 4 words).

7	6	5	4	3	2	1	0
0	0	1	1	0	0	0	0

OVF	INO	XRST	RRST	TXM	MCM	FSM	DLB
R	R	R/W	R/W	R/W	R/W	R/W	R/W

Receiver reset

- 0 Receiver in reset
- 1 Receiver enabled

Transmitter reset

- 0 Transmitter in reset
- 1 Transmitter enabled

CLKR pin status

- 0 Level on CLKR pin is low.
- 1 Level on CLKR pin is high.

Digital loopback mode

- 0 Digital loopback mode disabled
- 1 Digital loopback mode enabled

Frame sync mode

- 0 Continuous mode
- 1 Burst mode

Transmit clock source

- 0 External clock source
- 1 Internal clock source

Overflow flag

- 0 No overflow condition
- 1 Overflow detected in receive buffer

Transmit frame sync source

- 0 External frame sync source
- 1 Internal frame sync source

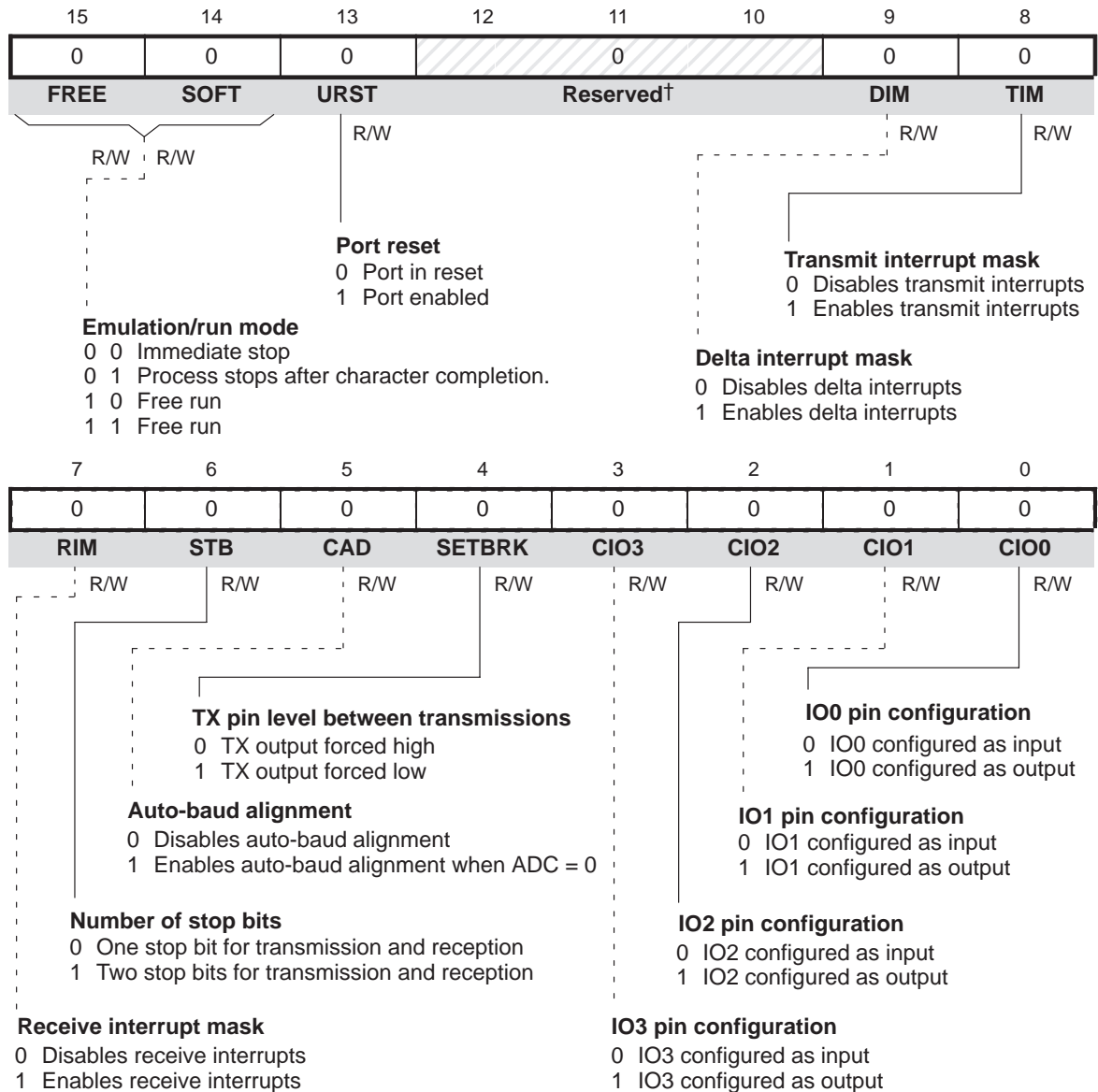
Asynchronous Serial Port Control Register (ASPCR) — I/O Address FFF5h

† These reserved bits are always read as 0s. Writes have no effect.

I/O Status Register (IOSR) — I/O Address FFF6h

15	14	13	12	11	10	9	8
0	0	0	1	1	0	0	0
Reserved†	ADC‡	BI‡	TEMT	THRE‡	FE‡	OE‡	DR‡

Transmit empty indicator
 0 ADTR and/or AXSR are full.
 1 ADTR and AXSR are empty; ADTR is ready for a new character to transmit.

Break interrupt indicator
 0 Normal operation
 1 Break has been detected on RX pin.

A detect complete bit
 0 Normal operation.
 1 CAD bit of ASPCR is 1 and A or a is received in ADTR.

Data ready indicator for receiver
 0 Receive register empty
 1 Character has been completely received.

Receive register overrun indicator
 0 No overrun error detected.
 1 Last character in ADTR was not read before the next character overwrote it.

Framing error indicator
 0 No framing error detected.
 1 Character received did not have a valid stop bit.

Transmit register empty indicator
 0 Transmit register not empty. Port operation normal.
 1 Transmit register empty. Port ready to receive new character.

7	6	5	4	3	2	1	0
X	X	X	X	X	X	X	X
DIO3‡	DIO2‡	DIO1‡	DIO0‡	IO3§	IO2§	IO1§	IO0§

Change detect bit for IO0
 0 No change detected on IO0
 1 Change detected on IO0

Change detect bit for IO1
 0 No change detected on IO1
 1 Change detected on IO1

Change detect bit for IO2
 0 No change detected on IO2
 1 Change detected on IO2

Change detect bit for IO3
 0 No change detected on IO3
 1 Change detected on IO3

IO0 pin status
 0 IO0 signal low
 1 IO0 signal high

IO1 pin status
 0 IO1 signal low
 1 IO1 signal high

IO2 pin status
 0 IO2 signal low
 1 IO2 signal high

IO3 pin status
 0 IO3 signal low
 1 IO3 signal high

† This reserved bit is always read as 0. Writes have no effect.

‡ When any one of these bits changes in response to the specified event, an interrupt request is generated on the TXRXINT line.

§ This bit can be written to only when the corresponding pin is configured (in the ASPCR) as an output.

TMS320C1x/C2x/C2xx/C5x Instruction Set Comparison

This appendix contains a table that compares the TMS320C1x, TMS320C2x, TMS320C2xx, and TMS320C5x instructions alphabetically. Each table entry shows the syntax for the instruction, indicates which devices support the instruction, and describes the operation of the instruction. Section B.1 shows a sample table entry and describes the symbols and abbreviations used in the table.

The TMS320C2x, TMS320C2xx, and TMS320C5x devices have *enhanced instructions*; enhanced instructions are single mnemonics that perform the functions of several similar instructions. Section B.2 summarizes the enhanced instructions.

This appendix does not cover topics such as opcodes, instruction timing, or addressing modes; in addition to this book, the following documents cover such topics in detail:

TMS320C1x User's Guide (literature number SPRU013)

TMS320C2x User's Guide (literature number SPRU014)

TMS320C5x User's Guide (literature number SPRU056)

Topic	Page
B.1 Using the Instruction Set Comparison Table	B-2
B.2 Enhanced Instructions	B-5
B.3 Instruction Set Comparison Table	B-6

B.1 Using the Instruction Set Comparison Table

To help you read the comparison table, this section provides an example of a table entry and a list of acronyms.

B.1.1 An Example of a Table Entry

In cases where more than one syntax is used, the first syntax is usually for direct addressing and the second is usually for indirect addressing. Where three or more syntaxes are used, the syntaxes are normally specific to a device.

This is how the AND instruction appears in the table:

Syntax	1x	2x	2xx	5x	Description
AND <i>dma</i>	√	√	√	√	AND With Accumulator TMS320C1x and TMS320C2x devices: AND the contents of the addressed data-memory location with the 16 LSBs of the accumulator. The 16 MSBs of the accumulator are ANDed with 0s. TMS320C2xx and TMS320C5x devices: AND the contents of the addressed data-memory location or a 16-bit immediate value with the contents of the accumulator. The 16 MSBs of the accumulator are ANDed with 0s. If a shift is specified, left shift the constant before the AND. Low-order bits below and high-order bits above the shifted value are treated as 0s.
AND { <i>ind</i> } [, <i>next ARP</i>]	√	√	√	√	
AND # <i>lk</i> [, <i>shift</i>]			√	√	

The first column, *Syntax*, states the mnemonic and the syntaxes for the AND instruction.

The checks in the second through the fifth columns, *1x*, *2x*, *2xx*, and *5x*, indicate the devices that can be used with each of the syntaxes.

- 1x refers to the TMS320C1x devices
- 2x refers to the TMS320C2x devices, including TMS320C25
- 2xx refers to the TMS320C2xx devices
- 5x refers to the TMS320C5x devices

In this example, you can use the first two syntaxes with TMS320C1x, TMS320C2x, TMS320C2xx, and TMS320C5x devices, but you can use the last syntax only with TMS320C2xx and TMS320C5x devices.

The sixth column, *Description*, briefly describes how the instruction functions. Often, an instruction functions slightly differently for the different devices: read the entire description before using the instruction.

B.1.2 Symbols and Acronyms Used in the Table

The following table lists the instruction set symbols and acronyms used throughout this chapter:

Table B–1. Symbols and Acronyms Used in the Instruction Set Summary

Symbol	Description	Symbol	Description
lk	16-bit immediate value	INTM	interrupt mask bit
k	8-bit immediate value	INTR	interrupt mode bit
{ind}	indirect address	OV	overflow bit
ACC	accumulator	P	program bus
ACCB	accumulator buffer	PA	port address
AR	auxiliary register	PC	program counter
ARCR	auxiliary register compare	PM	product shifter mode
ARP	auxiliary register pointer	pma	program-memory address
BMAR	block move address register	RPTC	repeat counter
BRCR	block repeat count register	shift, shift _n	shift value
C	carry bit	src	source address
DBMR	dynamic bit manipulation register	ST	status register
dma	data-memory address	SXM	sign-extension mode bit
DP	data-memory page pointer	TC	test/control bit
dst	destination address	T	temporary register
FO	format status list	TREGn	TMS320C5x temporary register (0–2)
FSX	external framing pulse	TXM	transmit mode status register
IMR	interrupt mask register	XF	XF pin status bit

Based on the device, this is how the indirect addressing operand {ind} is interpreted:

{ind}	'C1x:	{ * *+ *- }
	'C2x:	{ * *+ *- *0+ *0- *BR0+ *BR0- }
	'C2xx:	{ * *+ *- *0+ *0- *BR0+ *BR0- }
	'C5x:	{ * *+ *- *0+ *0- *BR0+ *BR0- }

where the possible options are separated by vertical bars (|). For example:

ADD {ind}

is interpreted as:

'C1x devices	ADD { * *+ *- }
'C2x devices	ADD { * *+ *- *0+ *0- *BR0+ *BR0- }
'C2xx devices	ADD { * *+ *- *0+ *0- *BR0+ *BR0- }
'C5x devices	ADD { * *+ *- *0+ *0- *BR0+ *BR0- }

Based on the device, these are the sets of values for shift, shift₁, and shift₂:

shift	'C1x:	0–15 (shift of 0–15 bits)
	'C2x:	0–15 (shift of 0–15 bits)
	'C2xx:	0–16 (shift of 0–16 bits)
	'C5x:	0–16 (shift of 0–16 bits)
shift ₁	'C1x:	n/a
	'C2x:	0–15 (shift of 0–15 bits)
	'C2xx:	0–16 (shift of 0–16 bits)
	'C5x:	0–16 (shift of 0–16 bits)
shift ₂	'C1x:	n/a
	'C2x:	n/a
	'C2xx:	0–15 (shift of 0–15 bits)
	'C5x:	0–15 (shift of 0–15 bits)

In some cases, the sets are smaller; in these cases, the valid sets are given in the *Description* column of the table.

B.2 Enhanced Instructions

An enhanced instruction is a single mnemonic that performs the functions of several similar instructions. For example, the enhanced instruction ADD performs the ADD, ADDH, ADDK, and ADLK functions and replaces any of these other instructions at assembly time. For example, when a program using ADDH is assembled for the 'C2xx or 'C5x, ADDH is replaced by an ADD instruction that performs the same function. These enhanced instructions are valid for TMS320C2x, TMS320C2xx, and TMS320C5x devices (not TMS320C1x).

Table B–2 below summarizes the enhanced instructions and the functions that the enhanced instructions perform (based on TMS320C1x/2x mnemonics).

Table B–2. Summary of Enhanced Instructions

Enhanced Instruction	Includes These Operations
ADD	ADD, ADDH, ADDK, ADLK
AND	AND, ANDK
BCND	BBNZ, BBZ, BC, BCND, BGEZ, BGZ, BIOZ, BLEZ, BLZ, BNC, BNV, BNZ, BV, BZ
BLDD	BLDD, BLKD
BLDP	BLDP, BLKP
CLRC	CLRC, CNFD, EINT, RC, RHM, ROVM, RSXM, RTC, RXF
LACC	LAC, LACC, LALK, ZALH
LACL	LACK, LACL, ZAC, ZALS
LAR	LAR, LARK, LRLK
LDP	LDP, LDPK
LST	LST, LST1
MAR	LARP, MAR
MPY	MPY, MPYK
OR	OR, ORK
RPT	RPT, RPTK
SETC	CNFP, DINT, SC, SETC, SHM, SOVM, SSSXM, STC, SXF
SUB	SUB, SUBH, SUBK

B.3 Instruction Set Comparison Table

Syntax	1x	2x	2xx	5x	Description
ABS	√	√	√	√	Absolute Value of Accumulator If the contents of the accumulator are less than zero, replace the contents with the 2s complement of the contents. If the contents are ≥ 0 , the accumulator is not affected.
ADCB				√	Add ACCB to Accumulator With Carry Add the contents of the ACCB and the value of the carry bit to the accumulator. If the result of the addition generates a carry from the accumulator's MSB, the carry bit is set to 1.
ADD <i>dma</i> [, <i>shift</i>] ADD { <i>ind</i> } [, <i>shift</i> [, <i>next ARP</i>]] ADD # <i>k</i> ADD # <i>lk</i> [, <i>shift2</i>]	√	√	√	√	Add to Accumulator With Shift TMS320C1x and TMS320C2x devices: Add the contents of the addressed data-memory location to the accumulator; if a shift is specified, left shift the contents of the location before the add. During shifting, low-order bits are zero filled, and high-order bits are sign extended. TMS320C2xx and TMS320C5x devices: Add the contents of the addressed data-memory location or an immediate value to the accumulator; if a shift is specified, left shift the data before the add. During shifting, low-order bits are zero filled, and high-order bits are sign extended if $SXM = 1$.
ADDB				√	Add ACCB to Accumulator Add the contents of the ACCB to the accumulator.
ADDC <i>dma</i> ADDC { <i>ind</i> } [, <i>next ARP</i>]		√	√	√	Add to Accumulator With Carry Add the contents of the addressed data-memory location and the carry bit to the accumulator.
ADDH <i>dma</i> ADDH { <i>ind</i> } [, <i>next ARP</i>]	√	√	√	√	Add High to Accumulator Add the contents of the addressed data-memory location to the 16 MSBs of the accumulator. The LSBs are not affected. If the result of the addition generates a carry, the carry bit is set to 1. TMS320C2x, TMS320C2xx, and TMS320C5x devices: If the result of the addition generates a carry from the accumulator's MSB, the carry bit is set to 1.

Syntax	1x	2x	2xx	5x	Description
ADDK #k		√	√	√	<p>Add to Accumulator Short Immediate</p> <p>TMS320C1x devices: Add an 8-bit immediate value to the accumulator.</p> <p>TMS320C2x, TMS320C2xx, and TMS320C5x devices: Add an 8-bit immediate value, right justified, to the accumulator with the result replacing the accumulator contents. The immediate value is treated as an 8-bit positive number; sign extension is suppressed.</p>
ADDS dma ADDS {ind} [, next ARP]	√	√	√	√	<p>Add to Accumulator With Sign Extension Suppressed</p> <p>Add the contents of the addressed data-memory location to the accumulator. The value is treated as a 16-bit unsigned number; sign extension is suppressed.</p>
ADDT dma ADDT {ind} [, next ARP]		√	√	√	<p>Add to Accumulator With Shift Specified by T Register</p> <p>Left shift the contents of the addressed data-memory location by the value in the 4 LSBs of the T register; add the result to the accumulator. If a shift is specified, left shift the data before the add. During shifting, low-order bits are zero filled, and high-order bits are sign extended if SXM = 1.</p> <p>TMS320C2xx and TMS320C5x devices: If the result of the addition generates a carry from the accumulator's MSB, the carry bit is set to 1.</p>
ADLK #lk [, shift]		√	√	√	<p>Add to Accumulator Long Immediate With Shift</p> <p>Add a 16-bit immediate value to the accumulator; if a shift is specified, left shift the value before the add. During shifting, low-order bits are zero filled, and high-order bits are sign extended if SXM = 1.</p>
ADRK #k		√	√	√	<p>Add to Auxiliary Register Short Immediate</p> <p>Add an 8-bit immediate value to the current auxiliary register.</p>

Syntax	1x	2x	2xx	5x	Description
AND <i>dma</i> AND { <i>ind</i> } [, <i>next ARP</i>] AND # <i>lk</i> [, <i>shift</i>]	√	√	√	√	AND With Accumulator TMS320C1x and TMS320C2x devices: AND the contents of the addressed data-memory location with the 16 LSBs of the accumulator. The 16 MSBs of the accumulator are ANDed with 0s. TMS320C2xx and TMS320C5x devices: AND the contents of the addressed data-memory location or a 16-bit immediate value with the contents of the accumulator. The 16 MSBs of the accumulator are ANDed with 0s. If a shift is specified, left shift the constant before the AND. Low-order bits below and high-order bits above the shifted value are treated as 0s.
ANDB				√	AND ACCB to Accumulator AND the contents of the ACCB to the accumulator.
ANDK # <i>lk</i> [, <i>shift</i>]		√	√	√	AND Immediate With Accumulator With Shift AND a 16-bit immediate value with the contents of the accumulator; if a shift is specified, left shift the constant before the AND.
APAC	√	√	√	√	Add P Register to Accumulator Add the contents of the P register to the accumulator. TMS320C2x, TMS320C2xx, and TMS320C5x devices: Before the add, left shift the contents of the P register as defined by the PM status bits.
APL [# <i>lk</i>] , <i>dma</i> APL [# <i>lk</i> ,] { <i>ind</i> } [, <i>next ARP</i>]				√ √	AND Data-Memory Value With DBMR or Long Constant AND the data-memory value with the contents of the DBMR or a long constant. If a long constant is specified, it is ANDed with the contents of the data-memory location. The result is written back into the data-memory location previously holding the first operand. If the result is 0, the TC bit is set to 1; otherwise, the TC bit is cleared.
B <i>pma</i> B <i>pma</i> [, { <i>ind</i> } [, <i>next ARP</i>]]	√		√		Branch Unconditionally Branch to the specified program-memory address. TMS320C2x and TMS320C2xx devices: Modify the current AR and ARP as specified.

Syntax	1x	2x	2xx	5x	Description
B [<i>D</i>] <i>pma</i> [, { <i>ind</i> } [, <i>next ARP</i>]]				√	<p>Branch Unconditionally With Optional Delay</p> <p>Modify the current auxiliary register and ARP as specified and pass control to the designated program-memory address. If you specify a delayed branch (BD), the next two instruction words (two 1-word instructions or one 2-word instruction) are fetched and executed before branching.</p>
BACC		√	√		<p>Branch to Address Specified by Accumulator</p> <p>Branch to the location specified by the 16 LSBs of the accumulator.</p>
BACC [<i>D</i>]				√	<p>Branch to Address Specified by Accumulator With Optional Delay</p> <p>Branch to the location specified by the 16 LSBs of the accumulator.</p> <p>If you specify a delayed branch (BACCD), the next two instruction words (two 1-word instructions or one 2-word instruction) are fetched and executed before branching.</p>
BANZ <i>pma</i> BANZ <i>pma</i> [, { <i>ind</i> } [, <i>next ARP</i>]]	√		√	√	<p>Branch on Auxiliary Register Not Zero</p> <p>If the contents of the 9 LSBs of the current auxiliary register (TMS320C1x) or the contents of the entire current auxiliary register (TMS320C2x) are ≠ 0, branch to the specified program-memory address.</p> <p>TMS320C2x and TMS320C2xx devices: Modify the current AR and ARP (if specified) or decrement the current AR (default). TMS320C1x devices: Decrement the current AR.</p>
BANZ [<i>D</i>] <i>pma</i> [, { <i>ind</i> } [, <i>next ARP</i>]]				√	<p>Branch on Auxiliary Register Not Zero With Optional Delay</p> <p>If the contents of the current auxiliary register are ≠ 0, branch to the specified program-memory address. Modify the current AR and ARP as specified, or decrement the current AR.</p> <p>If you specify a delayed branch (BANZD), the next two instruction words (two 1-word instructions or one 2-word instruction) are fetched and executed before branching.</p>

Syntax	1x	2x	2xx	5x	Description
BBNZ <i>pma</i> [, { <i>ind</i> } [, <i>next ARP</i>]]		√	√	√	<p>Branch on Bit ≠ Zero</p> <p>If the TC bit = 1, branch to the specified program-memory address.</p> <p>TMS320C2x devices: Modify the current AR and ARP as specified.</p> <p>TMS320C2xx and TMS320C5x devices: If the –p porting switch is used, modify the current AR and ARP as specified.</p>
BBZ <i>pma</i> [, { <i>ind</i> } [, <i>next ARP</i>]] BBZ <i>pma</i>		√	√	√	<p>Branch on Bit = Zero</p> <p>If the TC bit = 0, branch to the specified program-memory address.</p> <p>TMS320C2x devices: Modify the current AR and ARP as specified.</p> <p>TMS320C2xx and TMS320C5x devices: Modify the current AR and ARP as specified when the –p porting switch is used.</p>
BC <i>pma</i> [, { <i>ind</i> } [, <i>next ARP</i>]] BC <i>pma</i>		√	√	√	<p>Branch on Carry</p> <p>If the C bit = 1, branch to the specified program-memory address.</p> <p>TMS320C2x devices: Modify the current AR and ARP as specified.</p> <p>TMS320C2xx and TMS320C5x devices: Modify the current AR and ARP as specified when the –p porting switch is used.</p>
BCND <i>pma</i> , <i>cond</i> ₁ [, <i>cond</i> ₂] [, ...]			√		<p>Branch Conditionally</p> <p>Branch to the program-memory address if the specified conditions are met. Not all combinations of conditions are meaningful.</p>
BCND [<i>D</i>] <i>pma</i> , <i>cond</i> ₁ [, <i>cond</i> ₂] [, ...]				√	<p>Branch Conditionally With Optional Delay</p> <p>Branch to the program-memory address if the specified conditions are met. Not all combinations of conditions are meaningful.</p> <p>If you specify a delayed branch (BCNDD), the next two instruction words (two 1-word instructions or one 2-word instruction) are fetched and executed before branching.</p>

Syntax	1x	2x	2xx	5x	Description
BGEZ <i>pma</i> BGEZ <i>pma</i> [, { <i>ind</i> } [, <i>next ARP</i>]]	√		√	√	Branch if Accumulator ≥ Zero If the contents of the accumulator ≥ 0, branch to the specified program-memory address. TMS320C2x devices: Modify the current AR and ARP as specified. TMS320C2xx and TMS320C5x devices: Modify the current AR and ARP as specified when the –p porting switch is used.
BGZ <i>pma</i> BGZ <i>pma</i> [, { <i>ind</i> } [, <i>next ARP</i>]]	√		√	√	Branch if Accumulator > Zero If the contents of the accumulator are > 0, branch to the specified program-memory address. TMS320C2x devices: Modify the current AR and ARP as specified. TMS320C2xx and TMS320C5x devices: Modify the current AR and ARP as specified when the –p porting switch is used.
BIOZ <i>pma</i> BIOZ <i>pma</i> [, { <i>ind</i> } [, <i>next ARP</i>]]	√		√	√	Branch on I/O Status = Zero If the $\overline{\text{BIO}}$ pin is low, branch to the specified program-memory address. TMS320C2x devices: Modify the current AR and ARP as specified. TMS320C2xx and TMS320C5x devices: Modify the current AR and ARP as specified when the –p porting switch is used.
BIT <i>dma, bit code</i> BIT { <i>ind</i> }, <i>bit code</i> [, <i>next ARP</i>]		√	√	√	Test Bit Copy the specified bit of the data-memory value to the TC bit in ST1.
BITT <i>dma</i> BITT { <i>ind</i> } [, <i>next ARP</i>]		√	√	√	Test Bit Specified by T Register TMS320C2x and TMS320C2xx devices: Copy the specified bit of the data-memory value to the TC bit in ST1. The 4 LSBs of the T register specify which bit is copied. TMS320C5x devices: Copy the specified bit of the data-memory value to the TC bit in ST1. The 4 LSBs of the TREG2 specify which bit is copied.

Syntax	1x	2x	2xx	5x	Description
BLDD <i>#lk, dma</i> BLDD <i>#lk, {ind} [, next ARP]</i> BLDD <i>dma, #lk</i> BLDD <i>{ind}, #lk [, next ARP]</i> BLDD <i>BMAR, dma</i> BLDD <i>BMAR, {ind} [, next ARP]</i> BLDD <i>dma BMAR</i> BLDD <i>{ind}, BMAR [, next ARP]</i>			✓ ✓ ✓ ✓	✓ ✓ ✓ ✓ ✓ ✓ ✓	<p>Block Move From Data Memory to Data Memory</p> <p>Copy a block of data memory into data memory. The block of data memory is pointed to by <i>src</i>, and the destination block of data memory is pointed to by <i>dst</i>.</p> <p>TMS320C2xx devices: The word of the source and/or the destination space can be pointed to with a long immediate value or a data-memory address. You can use the RPT instruction with BLDD to move consecutive words, pointed to indirectly in data memory, to a contiguous program-memory space. The number of words to be moved is 1 greater than the number contained in the RPTC at the beginning of the instruction.</p> <p>TMS320C5x devices: The word of the source and/or the destination space can be pointed to with a long immediate value, the contents of the BMAR, or a data-memory address. You can use the RPT instruction with BLDD to move consecutive words, pointed to indirectly in data memory, to a contiguous program-memory space. The number of words to be moved is 1 greater than the number contained in the RPTC at the beginning of the instruction.</p>
BLDP <i>dma</i> BLDP <i>{ind} [, next ARP]</i>				✓ ✓	<p>Block Move From Data Memory to Program Memory</p> <p>Copy a block of data memory into program memory pointed to by the BMAR. You can use the RPT instruction with BLDP to move consecutive words, indirectly pointed to in data memory, to a contiguous program-memory space pointed to by the BMAR.</p>
BLEZ <i>pma</i> BLEZ <i>pma [, {ind} [, next ARP]]</i>	✓	✓	✓ ✓	✓ ✓	<p>Branch if Accumulator ≤ Zero</p> <p>If the contents of the accumulator are ≤ 0, branch to the specified program-memory address.</p> <p>TMS320C2x devices: Modify the current AR and ARP as specified.</p> <p>TMS320C2xx and TMS320C5x devices: Modify the current AR and ARP as specified when the $-p$ porting switch is used.</p>

Syntax	1x	2x	2xx	5x	Description
BLKD <i>dma1, dma2</i> BLKD <i>dma1, {ind} [, next ARP]</i>		√	√	√	Block Move From Data Memory to Data Memory Move a block of words from one location in data memory to another location in data memory. Modify the current AR and ARP as specified. RPT or RPTK must be used with BLKD, in the indirect addressing mode, if more than one word is to be moved. The number of words to be moved is 1 greater than the number contained in RPTC at the beginning of the instruction.
BLKP <i>pma, dma</i> BLKP <i>pma, {ind} [, next ARP]</i>		√	√	√	Block Move From Program Memory to Data Memory Move a block of words from a location in program memory to a location in data memory. Modify the current AR and ARP as specified. RPT or RPTK must be used with BLKD, in the indirect addressing mode, if more than one word is to be moved. The number of words to be moved is 1 greater than the number contained in RPTC at the beginning of the instruction.
BLPD <i>#pma, dma</i> BLPD <i>#pma, {ind} [, next ARP]</i> BLPD <i>BMAR, dma</i> BLPD <i>BMAR, {ind} [, next ARP]</i>			√	√	Block Move From Program Memory to Data Memory Copy a block of program memory into data memory. The block of program memory is pointed to by <i>src</i> , and the destination block of data memory is pointed to by <i>dst</i> . TMS320C2xx devices: The word of the source space can be pointed to with a long immediate value. You can use the RPT instruction with BLPD to move consecutive words that are pointed at indirectly in data memory to a contiguous program-memory space. TMS320C5x devices: The word of the source space can be pointed to with a long immediate value or the contents of the BMAR. You can use the RPT instruction with BLPD to move consecutive words that are pointed at indirectly in data memory to a contiguous program-memory space.
BLZ <i>pma</i> BLZ <i>pma [, {ind} [, next ARP]]</i>	√		√	√	Branch if Accumulator < Zero If the contents of the accumulator are < 0, branch to the specified program-memory address. TMS320C2x devices: Modify the current AR and ARP as specified. TMS320C2xx and TMS320C5x devices: Modify the current AR and ARP as specified when the -p porting switch is used.

Syntax	1x	2x	2xx	5x	Description
BNC <i>pma</i> [, { <i>ind</i> } [, <i>next ARP</i>]]		√	√	√	<p>Branch on No Carry</p> <p>If the C bit = 0, branch to the specified program-memory address.</p> <p>TMS320C2x devices: Modify the current AR and ARP as specified.</p> <p>TMS320C2xx and TMS320C5x devices: Modify the current AR and ARP as specified when the –p porting switch is used.</p>
BNV <i>pma</i> [, { <i>ind</i> } [, <i>next ARP</i>]]		√	√	√	<p>Branch if No Overflow</p> <p>If the OV flag is clear, branch to the specified program-memory address.</p> <p>TMS320C2x devices: Modify the current AR and ARP as specified.</p> <p>TMS320C2xx and TMS320C5x devices: Modify the current AR and ARP as specified when the –p porting switch is used.</p>
BNZ <i>pma</i> BNZ <i>pma</i> [, { <i>ind</i> } [, <i>next ARP</i>]]	√		√	√	<p>Branch if Accumulator ≠ Zero</p> <p>If the contents of the accumulator ≠ 0, branch to the specified program-memory address.</p> <p>TMS320C2x devices: Modify the current AR and ARP as specified.</p> <p>TMS320C2xx and TMS320C5x devices: Modify the current AR and ARP as specified when the –p porting switch is used.</p>
BSAR [<i>shift</i>]				√	<p>Barrel Shift</p> <p>In a single cycle, execute a 1- to 16-bit right arithmetic barrel shift of the accumulator. The sign extension is determined by the sign-extension mode bit in ST1.</p>
BV <i>pma</i> BV <i>pma</i> [, { <i>ind</i> } [, <i>next ARP</i>]]	√		√	√	<p>Branch on Overflow</p> <p>If the OV flag is set, branch to the specified program-memory address and clear the OV flag.</p> <p>TMS320C2x, TMS320C2xx, and TMS320C5x devices: Modify the current AR and ARP as specified.</p> <p>TMS320C2xx and TMS320C5x devices: To modify the AR and ARP, use the –p porting switch.</p>

Syntax	1x	2x	2xx	5x	Description
BZ <i>pma</i> BZ <i>pma</i> [, { <i>ind</i> } [, <i>next ARP</i>]]	√		√	√	Branch if Accumulator = Zero If the contents of the accumulator = 0, branch to the specified program-memory address. TMS320C2x, TMS320C2xx and TMS320C5x devices: Modify the current AR and ARP as specified. TMS320C2xx and TMS320C5x devices: To modify the AR and ARP, use the <i>-p</i> porting switch.
CALA	√	√	√		Call Subroutine Indirect The contents of the accumulator specify the address of a subroutine. Increment the PC, push the PC onto the stack, then load the 12 (TMS320C1x) or 16 (TMS320C2x/C2xx) LSBs of the accumulator into the PC.
CALA [<i>D</i>]				√	Call Subroutine Indirect With Optional Delay The contents of the accumulator specify the address of a subroutine. Increment the PC and push it onto the stack; then load the 16 LSBs of the accumulator into the PC. If you specify a delayed branch (CALAD), the next two instruction words (two 1-word instructions or one 2-word instruction) are fetched and executed before the call.
CALL <i>pma</i> CALL <i>pma</i> [, { <i>ind</i> } [, <i>next ARP</i>]]	√		√		Call Subroutine The contents of the addressed program-memory location specify the address of a subroutine. Increment the PC by 2, push the PC onto the stack, then load the specified program-memory address into the PC. TMS320C2x and TMS320C2xx devices: Modify the current AR and ARP as specified.
CALL [<i>D</i>] <i>pma</i> [, { <i>ind</i> } [, <i>next ARP</i>]]				√	Call Unconditionally With Optional Delay The contents of the addressed program-memory location specify the address of a subroutine. Increment the PC and push the PC onto the stack; then load the specified program-memory address (symbolic or numeric) into the PC. Modify the current AR and ARP as specified. If you specify a delayed branch (CALLD), the next two instruction words (two 1-word instructions or one 2-word instruction) are fetched and executed before the call.

Syntax	1x	2x	2xx	5x	Description
CC <i>pma, cond₁ [, cond₂] [, ...]</i>			√		Call Conditionally If the specified conditions are met, control is passed to the pma. Not all combinations of conditions are meaningful.
CC[D] <i>pma, cond₁ [, cond₂] [, ...]</i>				√	Call Conditionally With Optional Delay If the specified conditions are met, control is passed to the pma. Not all combinations of conditions are meaningful. If you specify a delayed branch (CCD), the next two instruction words (two 1-word instructions or one 2-word instruction) are fetched and executed before the call.
CLRC <i>control bit</i>			√	√	Clear Control Bit Set the specified control bit to a logic 0. Maskable interrupts are enabled immediately after the CLRC instruction executes.
CMPL		√	√	√	Complement Accumulator Complement the contents of the accumulator (1s complement).
CMPR <i>CM</i>		√	√	√	Compare Auxiliary Register With AR0 Compare the contents of the current auxiliary register to AR0, based on the following cases: If CM = 00 ₂ , test whether AR(ARP) = AR0. If CM = 01 ₂ , test whether AR(ARP) < AR0. If CM = 10 ₂ , test whether AR(ARP) > AR0. If CM = 11 ₂ , test whether AR(ARP) ≠ AR0. If the result is true, load a 1 into the TC status bit; otherwise, load a 0 into the TC bit. The comparison does not affect the tested registers. TMS320C5x devices: Compare the contents of the auxiliary register with the ARCR.
CNFD		√	√	√	Configure Block as Data Memory Configure on-chip RAM block B0 as data memory. Block B0 is mapped into data-memory locations 512h–767h. TMS320C5x devices: Block B0 is mapped into data-memory locations 512h–1023h.

Syntax	1x	2x	2xx	5x	Description
CNFP		√	√	√	<p>Configure Block as Program Memory</p> <p>Configure on-chip RAM block B0 as program memory. Block B0 is mapped into program-memory locations 65280h–65535h.</p> <p>TMS320C5x devices: Block B0 is mapped into data-memory locations 65024h–65535h.</p>
CONF <i>2-bit constant</i>		√			<p>Configure Block as Program Memory</p> <p>Configure on-chip RAM block B0/B1/B2/B3 as program memory. For information on the memory mapping of B0/B1/B2/B3, see the <i>TMS320C2x User's Guide</i>.</p>
CPL [<i>#lk,</i>] <i>dma</i> CPL [<i>#lk,</i>] <i>{ind}</i> [, <i>next ARP</i>]				√	<p>Compare DBMR or Immediate With Data Value</p> <p>Compare two quantities: If the two quantities are equal, set the TC bit to 1; otherwise, clear the TC bit.</p>
CRGT				√	<p>Test for ACC > ACCB</p> <p>Compare the contents of the ACC with the contents of the ACCB, then load the larger signed value into both registers and modify the carry bit according to the comparison result. If the contents of ACC are greater than or equal to the contents of ACCB, set the carry bit to 1.</p>
CRLT				√	<p>Test for ACC < ACCB</p> <p>Compare the contents of the ACC with the contents of the ACCB, then load the smaller signed value into both registers and modify the carry bit according to the comparison result. If the contents of ACC are less than the contents of ACCB, clear the carry bit.</p>
DINT	√	√	√	√	<p>Disable Interrupts</p> <p>Disable all interrupts; set the INTM to 1. Maskable interrupts are disabled immediately after the DINT instruction executes. <u>D</u>INT does not disable the unmaskable interrupt RS; DINT does not affect the IMR.</p>
DMOV <i>dma</i> DMOV <i>{ind}</i> [, <i>next ARP</i>]	√	√	√	√	<p>Data Move in Data Memory</p> <p>Copy the contents of the addressed data-memory location into the next higher address. DMOV moves data only within on-chip RAM blocks.</p> <p>TMS320C2x, TMS320C2xx, and TMS320C5x devices: The on-chip RAM blocks are B0 (when configured as data memory), B1, and B2.</p>

Syntax	1x	2x	2xx	5x	Description
EINT	√	√	√	√	<p>Enable Interrupts</p> <p>Enable all interrupts; clear the INTM to 0. Maskable interrupts are enabled immediately after the EINT instruction executes.</p>
EXAR				√	<p>Exchange ACCB With ACC</p> <p>Exchange the contents of the ACC with the contents of the ACCB.</p>
FORT <i>1-bit constant</i>		√			<p>Format Serial Port Registers</p> <p>Load the FO with a 0 or a 1. If FO = 0, the registers are configured to receive/transmit 16-bit words. If FO = 1, the registers are configured to receive/transmit 8-bit bytes.</p>
IDLE		√	√	√	<p>Idle Until Interrupt</p> <p>Forces an executing program to halt execution and wait until it receives a reset or an interrupt. The device remains in an idle state until it is interrupted.</p>
IDLE2				√	<p>Idle Until Interrupt—Low-Power Mode</p> <p>Removes the functional clock input from the internal device; this allows for an extremely low-power mode. The IDLE2 instruction forces an executing program to halt execution and wait until it receives a reset or unmasked interrupt.</p>
IN <i>dma, PA</i>	√	√	√	√	<p>Input Data From Port</p> <p>Read a 16-bit value from one of the external I/O ports into the addressed data-memory location.</p> <p>TMS320C1x devices: This is a 2-cycle instruction. During the first cycle, the port <u>address</u> is sent to address lines A2/PA2–A0/PA0; <u>DEN</u> goes low, strobing in the data that the addressed peripheral places on data bus D15–D0.</p> <p>TMS320C2x devices: The <u>IS</u> line goes low to indicate an I/O access, and the <u>STRB</u>, <u>R/W</u>, and <u>READY</u> timings are the same as for an external data-memory read.</p> <p>TMS320C2xx and TMS320C5x devices: The <u>IS</u> line goes low to indicate an I/O access, and the <u>STRB</u>, <u>RD</u>, and <u>READY</u> timings are the same as for an external data-memory read.</p>
IN <i>{ind}, PA [, next ARP]</i>	√	√	√	√	

Syntax	1x	2x	2xx	5x	Description
INTR <i>K</i>			√	√	Soft Interrupt Transfer program control to the program-memory address specified by <i>K</i> (an integer from 0 to 31). This instruction allows you to use your software to execute any interrupt service routine. The interrupt vector locations are spaced apart by two addresses (0h, 2h, 4h, ... , 3Eh), allowing a two-word branch instruction to be placed at each location.
LAC <i>dma</i> [, <i>shift</i>] LAC { <i>ind</i> } [, <i>shift</i> [, <i>next ARP</i>]]	√	√	√	√	Load Accumulator With Shift Load the contents of the addressed data-memory location into the accumulator. If a shift is specified, left shift the value before loading it into the accumulator. During shifting, low-order bits are zero filled, and high-order bits are sign extended if <i>SXM</i> = 1.
LACB				√	Load Accumulator With ACCB Load the contents of the accumulator buffer into the accumulator.
LACC <i>dma</i> [, <i>shift</i> ₁] LACC { <i>ind</i> } [, <i>shift</i> ₁ [, <i>next ARP</i>]] LACC # <i>lk</i> [, <i>shift</i> ₂]		√	√	√	Load Accumulator With Shift Load the contents of the addressed data-memory location or the 16-bit constant into the accumulator. If a shift is specified, left shift the value before loading it into the accumulator. During shifting, low-order bits are zero filled, and high-order bits are sign extended if <i>SXM</i> = 1.
LACK <i>8-bit constant</i>	√	√	√	√	Load Accumulator Immediate Short Load an 8-bit constant into the accumulator. The 24 MSBs of the accumulator are zeroed.
LACL <i>dma</i> LACL { <i>ind</i> } [, <i>next ARP</i>] LACL # <i>k</i>			√	√	Load Low Accumulator and Clear High Accumulator Load the contents of the addressed data-memory location or zero-extended 8-bit constant into the 16 LSBs of the accumulator. The MSBs of the accumulator are zeroed. The data is treated as a 16-bit unsigned number. TMS320C2xx: A constant of 0 clears the contents of the accumulator to 0 with no sign extension.

Syntax	1x	2x	2xx	5x	Description
LACT <i>dma</i> LACT { <i>ind</i> } [, <i>next ARP</i>]		√	√	√	Load Accumulator With Shift Specified by T Register Left shift the contents of the addressed data-memory location by the value specified in the 4 LSBs of the T register; load the result into the accumulator. If a shift is specified, left shift the value before loading it into the accumulator. During shifting, low-order bits are zero filled, and high-order bits are sign extended if SXM = 1.
LALK # <i>lk</i> [, <i>shift</i>]		√	√	√	Load Accumulator Long Immediate With Shift Load a 16-bit immediate value into the accumulator. If a shift is specified, left shift the constant before loading it into the accumulator. During shifting, low-order bits are zero filled, and high-order bits are sign extended if SXM = 1.
LAMM <i>dma</i> LAMM { <i>ind</i> } [, <i>next ARP</i>]				√ √	Load Accumulator With Memory-Mapped Register Load the contents of the addressed memory-mapped register into the low word of the accumulator. The 9 MSBs of the data-memory address are cleared, regardless of the current value of DP or the 9 MSBs of AR (ARP).
LAR <i>AR, dma</i> LAR <i>AR, {ind}</i> [, <i>next ARP</i>] LAR <i>AR, #k</i> LAR <i>AR, #lk</i>	√ √	√ √	√ √ √	√ √ √	Load Auxiliary Register TMS320C1x and TMS320C2x devices: Load the contents of the addressed data-memory location into the designated auxiliary register. TMS320C25, TMS320C2xx, and TMS320C5x devices: Load the contents of the addressed data-memory location or an 8-bit or 16-bit immediate value into the designated auxiliary register.
LARK <i>AR, 8-bit constant</i>	√	√	√	√	Load Auxiliary Register Immediate Short Load an 8-bit positive constant into the designated auxiliary register.
LARP <i>1-bit constant</i> LARP <i>3-bit constant</i>	√	√	√	√	Load Auxiliary Register Pointer TMS320C1x devices: Load a 1-bit constant into the auxiliary register pointer (specifying AR0 or AR1). TMS320C2x, TMS320C2xx, and TMS320C5x devices: Load a 3-bit constant into the auxiliary register pointer (specifying AR0–AR7).

Syntax	1x	2x	2xx	5x	Description
LDP <i>dma</i> LDP { <i>ind</i> } [, <i>next ARP</i>] LDP # <i>k</i>	√	√	√	√	Load Data-Memory Page Pointer TMS320C1x devices: Load the LSB of the contents of the addressed data-memory location into the DP register. All high-order bits are ignored. DP = 0 defines page 0 (words 0–127), and DP = 1 defines page 1 (words 128–143/255). TMS320C2x, TMS320C2xx, and TMS320C5x devices: Load the 9 LSBs of the addressed data-memory location or a 9-bit immediate value into the DP register. The DP and 7-bit data-memory address are concatenated to form 16-bit data-memory addresses.
LDPK <i>1-bit constant</i> LDPK <i>9-bit constant</i>	√		√	√	Load Data-Memory Page Pointer Immediate TMS320C1x devices: Load a 1-bit immediate value into the DP register. DP = 0 defines page 0 (words 0–127), and DP = 1 defines page 1 (words 128–143/255). TMS320C2x, TMS320C2xx, and TMS320C5x devices: Load a 9-bit immediate into the DP register. The DP and 7-bit data-memory address are concatenated to form 16-bit data-memory addresses. DP ≥ 8 specifies external data memory. DP = 4 through 7 specifies on-chip RAM blocks B0 or B1. Block B2 is located in the upper 32 words of page 0.
LMMR <i>dma, #lk</i> LMMR { <i>ind</i> }, # <i>lk</i> [, <i>next ARP</i>]				√	Load Memory-Mapped Register Load the contents of the memory-mapped register pointed at by the 7 LSBs of the direct or indirect data-memory value into the long immediate addressed data-memory location. The 9 MSBs of the data-memory address are cleared, regardless of the current value of DP or the 9 MSBs of AR (ARP).
LPH <i>dma</i> LPH { <i>ind</i> } [, <i>next ARP</i>]		√	√	√	Load High P Register Load the contents of the addressed data-memory location into the 16 MSBs of the P register; the LSBs are not affected.
LRLK <i>AR, lk</i>		√	√	√	Load Auxiliary Register Long Immediate Load a 16-bit immediate value into the designated auxiliary register.
LST <i>dma</i> LST { <i>ind</i> } [, <i>next ARP</i>]	√	√	√	√	Load Status Register Load the contents of the addressed data-memory location into the ST (TMS320C1x) or into ST0 (TMS320C2x/2xx/5x).

Syntax	1x	2x	2xx	5x	Description
LST #n, dma LST #n, {ind} [, next ARP]		√	√	√	Load Status Register n Load the contents of the addressed data-memory location into STn.
LST1 dma LST1 {ind} [, next ARP]		√	√	√	Load ST1 Load the contents of the addressed data-memory location into ST1.
LT dma LT {ind} [, next ARP]	√	√	√	√	Load T Register Load the contents of the addressed data-memory location into the T register (TMS320C1x/2x/2xx) or TREG0 (TMS320C5x).
LTA dma LTA {ind} [, next ARP]	√	√	√	√	Load T Register and Accumulate Previous Product Load the contents of the addressed data-memory location into T register (TMS320C1x/2x/2xx) or TREG0 (TMS320C5x) and add the contents of the P register to the accumulator. TMS320C2x, TMS320C2xx, and TMS320C5x devices: Before the add, shift the contents of the P register as specified by the PM status bits.
LTD dma LTD {ind} [, next ARP]	√	√	√	√	Load T Register, Accumulate Previous Product, and Move Data Load the contents of the addressed data-memory location into the T register (TMS320C1x/2x/2xx) or TREG0 (TMS320C5x), add the contents of the P register to the accumulator, and copy the contents of the specified location into the next higher address (both data-memory locations must reside in on-chip data RAM). TMS320C2x, TMS320C2xx, and TMS320C5x devices: Before the add, shift the contents of the P register as specified by the PM status bits.
LTP dma LTP {ind} [, next ARP]		√	√	√	Load T Register, Store P Register in Accumulator Load the contents of the addressed data-memory location into the T register (TMS320C1x/2x/2xx) or TREG0 (TMS320C5x). Store the contents of the product register into the accumulator.
LTS dma LTS {ind} [, next ARP]		√	√	√	Load T Register, Subtract Previous Product Load the contents of the addressed data-memory location into the T register (TMS320C1x/2x/2xx) or TREG0 (TMS320C5x). Shift the contents of the product register as specified by the PM status bits, and subtract the result from the accumulator.

Syntax	1x	2x	2xx	5x	Description
MAC <i>pma, dma</i> MAC <i>pma, {ind} [, next ARP]</i>		√	√	√	Multiply and Accumulate Multiply a data-memory value by a program-memory value and add the previous product (shifted as specified by the PM status bits) to the accumulator.
MACD <i>dma, pma</i> MACD <i>pma, {ind} [, next ARP]</i>		√	√	√	Multiply and Accumulate With Data Move Multiply a data-memory value by a program-memory value and add the previous product (shifted as specified by the PM status bits) to the accumulator. If the data-memory address is in on-chip RAM block B0, B1, or B2, copy the contents of the address to the next higher address.
MADD <i>dma</i> MADD <i>{ind} [, next ARP]</i>				√ √	Multiply and Accumulate With Data Move and Dynamic Addressing Multiply a data-memory value by a program-memory value and add the previous product (shifted as defined by the PM status bits) into the accumulator. The program-memory address is contained in the BMAR; this allows for dynamic addressing of coefficient tables. MADD functions the same as MADS, with the addition of data move for on-chip RAM blocks.
MADS <i>dma</i> MADS <i>{ind} [, next ARP]</i>				√ √	Multiply and Accumulate With Dynamic Addressing Multiply a data-memory value by a program-memory value and add the previous product (shifted as defined by the PM status bits) into the accumulator. The program-memory address is contained in the BMAR; this allows for dynamic addressing of coefficient tables.
MAR <i>dma</i> MAR <i>{ind} [, next ARP]</i>	√	√	√	√	Modify Auxiliary Register Modify the current AR or ARP as specified. MAR acts as NOP in indirect addressing mode.
MPY <i>dma</i> MPY <i>{ind} [, next ARP]</i> MPY <i>#k</i> MPY <i>#lk</i>	√	√	√	√	Multiply TMS320C1x and TMS320C2x devices: Multiply the contents of the T register by the contents of the addressed data-memory location; place the result in the P register. TMS320C2xx and TMS320C5x devices: Multiply the contents of the T register (TMS320C2xx) or TREG0 (TMS320C5x) by the contents of the addressed data-memory location or a 13-bit or 16-bit immediate value; place the result in the P register.

Syntax	1x	2x	2xx	5x	Description
MPYA <i>dma</i> MPYA { <i>ind</i> } [, <i>next ARP</i>]		√	√	√	Multiply and Accumulate Previous Product Multiply the contents of the T register (TMS320C2x/2xx) or TREG0 (TMS320C5x) by the contents of the addressed data-memory location; place the result in the P register. Add the previous product (shifted as specified by the PM status bits) to the accumulator.
MPYK <i>13-bit constant</i>	√	√	√	√	Multiply Immediate Multiply the contents of the T register (TMS320C2x/2xx) or TREG0 (TMS320C5x) by a signed 13-bit constant; place the result in the P register.
MPYS <i>dma</i> MPYS { <i>ind</i> } [, <i>next ARP</i>]		√	√	√	Multiply and Subtract Previous Product Multiply the contents of the T register (TMS320C2x/2xx) or TREG0 (TMS320C5x) by the contents of the addressed data-memory location; place the result in the P register. Subtract the previous product (shifted as specified by the PM status bits) from the accumulator.
MPYU <i>dma</i> MPYU { <i>ind</i> } [, <i>next ARP</i>]		√	√	√	Multiply Unsigned Multiply the unsigned contents of the T register (TMS320C2x/2xx) or TREG0 (TMS320C5x) by the unsigned contents of the addressed data-memory location; place the result in the P register.
NEG		√	√	√	Negate Accumulator Negate (2s complement) the contents of the accumulator.
NMI			√	√	Nonmaskable Interrupt Force the program counter to the nonmaskable interrupt vector location 24h. NMI has the same effect as a hardware nonmaskable interrupt.
NOP	√	√	√	√	No Operation Perform no operation.
NORM NORM { <i>ind</i> }		√	√	√	Normalize Contents of Accumulator Normalize a signed number in the accumulator.
OPL [# <i>lk</i> ,] <i>dma</i> OPL [# <i>lk</i> ,] { <i>ind</i> } [, <i>next ARP</i>]				√	OR With DBMR or Long Immediate If a long immediate is specified, OR it with the value at the specified data-memory location; otherwise, the second operand of the OR operation is the contents of the DBMR. The result is written back into the data-memory location previously holding the first operand.

Syntax	1x	2x	2xx	5x	Description
OR <i>dma</i> OR { <i>ind</i> } [, <i>next ARP</i>] OR # <i>lk</i> [, <i>shift</i>]	√	√	√	√	OR With Accumulator TMS320C1x and TMS320C2x devices: OR the 16 LSBs of the accumulator with the contents of the addressed data-memory location. The 16 MSBs of the accumulator are ORed with 0s. TMS320C2xx and TMS320C5x devices: OR the 16 LSBs of the accumulator or a 16-bit immediate value with the contents of the addressed data-memory location. If a shift is specified, left-shift before ORing. Low-order bits below and high-order bits above the shifted value are treated as 0s.
ORB				√	OR ACCB With Accumulator OR the contents of the ACCB with the contents of the accumulator. ORB places the result in the accumulator.
ORK # <i>lk</i> [, <i>shift</i>]		√	√	√	OR Immediate With Accumulator with Shift OR a 16-bit immediate value with the contents of the accumulator. If a shift is specified, left-shift the constant before ORing. Low-order bits below and high-order bits above the shifted value are treated as 0s.
OUT <i>dma, PA</i> OUT { <i>ind</i> }, <i>PA</i> [, <i>next ARP</i>]	√	√	√	√	Output Data to Port Write a 16-bit value from a data-memory location to the specified I/O port. TMS320C1x devices: The first cycle of this instruction places the port address onto <u>address</u> lines A2/PA2–A0/PA0. During the same cycle, <u>WE</u> goes low and the data word is placed on the data bus D15–D0. TMS320C2x, TMS320C2xx, and TMS320C5x devices: The <u>IS</u> line goes low to indicate an I/O access; the STRB, R/W, and READY timings are the same as for an external data-memory write.
PAC	√	√	√	√	Load Accumulator With P Register Load the contents of the P register into the accumulator. TMS320C2x, TMS320C2xx, and TMS320C5x devices: Before the load, shift the P register as specified by the PM status bits.
POP	√	√	√	√	Pop Top of Stack to Low Accumulator Copy the contents of the top of the stack into the 12 (TMS320C1x) or 16 (TMS320C2x/2xx/5x) LSBs of the accumulator and then pop the stack one level. The MSBs of the accumulator are zeroed.

Syntax	1x	2x	2xx	5x	Description
POPD <i>dma</i> POPD { <i>ind</i> } [, <i>next ARP</i>]		√	√	√	Pop Top of Stack to Data Memory Transfer the value on the top of the stack into the addressed data-memory location and then pop the stack one level.
PSHD <i>dma</i> PSHD { <i>ind</i> } [, <i>next ARP</i>]		√	√	√	Push Data-Memory Value Onto Stack Copy the addressed data-memory location onto the top of the stack. The stack is pushed down one level before the value is copied.
PUSH	√	√	√	√	Push Low Accumulator Onto Stack Copy the contents of the 12 (TMS320C1x) or 16 (TMS320C2x/2xx/5x) LSBs of the accumulator onto the top of the hardware stack. The stack is pushed down one level before the value is copied.
RC		√	√	√	Reset Carry Bit Reset the C status bit to 0.
RET	√	√	√		Return From Subroutine Copy the contents of the top of the stack into the PC and pop the stack one level.
RET[D]				√	Return From Subroutine With Optional Delay Copy the contents of the top of the stack into the PC and pop the stack one level. If you specify a delayed branch (RETD), the next two instruction words (two 1-word instructions or one 2-word instruction) are fetched and executed before the return.
RETC <i>cond</i> ₁ [, <i>cond</i> ₂] [, ...]			√		Return Conditionally If the specified conditions are met, RETC performs a standard return. Not all combinations of conditions are meaningful.
RETC[D] <i>cond</i> ₁ [, <i>cond</i> ₂] [, ...]				√	Return Conditionally With Optional Delay If the specified conditions are met, RETC performs a standard return. Not all combinations of conditions are meaningful. If you specify a delayed branch (RETCD), the next two instruction words (two 1-word instructions or one 2-word instruction) are fetched and executed before the return.

Syntax	1x	2x	2xx	5x	Description
RETE				√	Enable Interrupts and Return From Interrupt Copy the contents of the top of the stack into the PC and pop the stack one level. RETE automatically clears the global interrupt enable bit and pops the shadow registers (stored when the interrupt was taken) back into their corresponding strategic registers. The following registers are shadowed: ACC, ACCB, PREG, ST0, ST1, PMST, ARCR, INDX, TREG0, TREG1, TREG2.
RETI				√	Return From Interrupt Copy the contents of the top of the stack into the PC and pop the stack one level. RETI also pops the values in the shadow registers (stored when the interrupt was taken) back into their corresponding strategic registers. The following registers are shadowed: ACC, ACCB, PREG, ST0, ST1, PMST, ARCR, INDX, TREG0, TREG1, TREG2.
RFSM		√			Reset Serial Port Frame Synchronization Mode Reset the FSM status bit to 0.
RHM		√		√	Reset Hold Mode Reset the HM status bit to 0.
ROL		√	√	√	Rotate Accumulator Left Rotate the accumulator left one bit.
ROLB				√	Rotate ACCB and Accumulator Left Rotate the ACCB and the accumulator left by one bit; this results in a 65-bit rotation.
ROR		√	√	√	Rotate Accumulator Right Rotate the accumulator right one bit.
RORB				√	Rotate ACCB and Accumulator Right Rotate the ACCB and the accumulator right one bit; this results in a 65-bit rotation.
ROVM	√	√	√	√	Reset Overflow Mode Reset the OVM status bit to 0; this disables overflow mode.

Syntax	1x	2x	2xx	5x	Description
RPT <i>dma</i>		√	√	√	Repeat Next Instruction TMS320C2x devices: Load the 8 LSBs of the addressed value into the RPTC; the instruction following RPT is executed the number of times indicated by RPTC + 1. TMS320C2xx and TMS320C5x devices: Load the 8 LSBs of the addressed value or an 8-bit or 16-bit immediate value into the RPTC; the instruction following RPT is repeated <i>n</i> times, where <i>n</i> is RPTC+1.
RPT { <i>ind</i> } [, <i>next ARP</i>]		√	√	√	
RPT # <i>k</i>			√	√	
RPT # <i>lk</i>			√	√	
RPTB <i>pma</i>				√	Repeat Block RPTB repeats a block of instructions the number of times specified by the memory-mapped BRCCR without any penalty for looping. The BRCCR must be loaded before RPTB is executed.
RPTK # <i>k</i>		√	√	√	Repeat Instruction as Specified by Immediate Value Load the 8-bit immediate value into the RPTC; the instruction following RPTK is executed the number of times indicated by RPTC + 1.
RPTZ # <i>lk</i>				√	Repeat Preceded by Clearing the Accumulator and P Register Clear the accumulator and product register and repeat the instruction following RPTZ <i>n</i> times, where <i>n</i> = <i>lk</i> + 1.
RSXM		√	√	√	Reset Sign-Extension Mode Reset the SXM status bit to 0; this suppresses sign extension on shifted data values for the following arithmetic instructions: ADD, ADDT, ADLK, LAC, LACT, LALK, SBLK, SUB, and SUBT.
RTC		√	√	√	Reset Test/Control Flag Reset the TC status bit to 0.
RTXM		√			Reset Serial Port Transmit Mode Reset the TXM status bit to 0; this configures the serial port transmit section in a mode where it is controlled by an FSX.
RXF		√	√	√	Reset External Flag Reset XF pin and the XF status bit to 0.
SACB				√	Store Accumulator in ACCB Copy the contents of the accumulator into the ACCB.

Syntax	1x	2x	2xx	5x	Description
SACH <i>dma</i> [, <i>shift</i>] SACH { <i>ind</i> } [, <i>shift</i> [, <i>next ARP</i>]]	√	√	√	√	Store High Accumulator With Shift Copy the contents of the accumulator into a shifter. Shift the entire contents 0, 1, or 4 bits (TMS320C1x) or from 0 to 7 bits (TMS320C2x/2xx/5x), and then copy the 16 MSBs of the shifted value into the addressed data-memory location. The accumulator is not affected.
SACL <i>dma</i> SACL <i>dma</i> [, <i>shift</i>] SACL { <i>ind</i> } [, <i>shift</i> [, <i>next ARP</i>]]	√	√	√	√	Store Low Accumulator With Shift TMS320C1x devices: Store the 16 LSBs of the accumulator into the addressed data-memory location. A shift value of 0 must be specified if the ARP is to be changed. TMS320C2x, TMS320C2xx, and TMS320C5x devices: Store the 16 LSBs of the accumulator into the addressed data-memory location. If a shift is specified, shift the contents of the accumulator before storing. Shift values are 0, 1, or 4 bits (TMS320C20) or from 0 to 7 bits (TMS320C2x/2xx/5x).
SAMM <i>dma</i> SAMM { <i>ind</i> } [, <i>next ARP</i>]				√	Store Accumulator in Memory-Mapped Register Store the low word of the accumulator in the addressed memory-mapped register. The upper 9 bits of the data address are cleared, regardless of the current value of DP or the 9 MSBs of AR (ARP).
SAR <i>AR, dma</i> SAR <i>AR, {ind}</i> [, <i>next ARP</i>]	√	√	√	√	Store Auxiliary Register Store the contents of the specified auxiliary register in the addressed data-memory location.
SATH				√	Barrel-Shift Accumulator as Specified by T Register 1 If bit 4 of TREG1 is a 1, barrel-shift the accumulator right by 16 bits; otherwise, the accumulator is unaffected.
SATL				√	Barrel-Shift Low Accumulator as Specified by T Register 1 Barrel-shift the accumulator right by the value specified in the 4 LSBs of TREG1.
SBB				√	Subtract ACCB From Accumulator Subtract the contents of the ACCB from the accumulator. The result is stored in the accumulator; the accumulator buffer is not affected.

Syntax	1x	2x	2xx	5x	Description
SBBB				√	Subtract ACCB From Accumulator With Borrow Subtract the contents of the ACCB and the logical inversion of the carry bit from the accumulator. The result is stored in the accumulator; the accumulator buffer is not affected. Clear the carry bit if the result generates a borrow.
SBLK #lk [, shift]		√	√	√	Subtract From Accumulator Long Immediate With Shift Subtract the immediate value from the accumulator. If a shift is specified, left shift the value before subtracting. During shifting, low-order bits are zero filled, and high-order bits are sign extended if SXM = 1.
SBRK #k		√	√	√	Subtract From Auxiliary Register Short Immediate Subtract the 8-bit immediate value from the designated auxiliary register.
SC		√	√	√	Set Carry Bit Set the C status bit to 1.
SETC control bit			√	√	Set Control Bit Set the specified control bit to a logic 1. Maskable interrupts are disabled immediately after the SETC instruction executes.
SFL		√	√	√	Shift Accumulator Left Shift the contents of the accumulator left one bit.
SFLB				√	Shift ACCB and Accumulator Left Shift the concatenation of the accumulator and the ACCB left one bit. The LSB of the ACCB is cleared to 0, and the MSB of the ACCB is shifted into the carry bit.
SFR		√	√	√	Shift Accumulator Right Shift the contents of the accumulator right one bit. If SXM = 1, SFR produces an arithmetic right shift. If SXM = 0, SFR produces a logic right shift.
SFRB				√	Shift ACCB and Accumulator Right Shift the concatenation of the accumulator and the ACCB right 1 bit. The LSB of the ACCB is shifted into the carry bit. If SXM = 1, SFRB produces an arithmetic right shift. If SXM = 0, SFRB produces a logic right shift.
SFSM		√			Set Serial Port Frame Synchronization Mode Set the FSM status bit to 1.

Syntax	1x	2x	2xx	5x	Description
SHM		√		√	Set Hold Mode Set the HM status bit to 1.
SMMR <i>dma, #lk</i> SMMR { <i>ind</i> }, #lk [, <i>next ARP</i>]				√ √	Store Memory-Mapped Register Store the memory-mapped register value, pointed at by the 7 LSBs of the data-memory address, into the long immediate addressed data-memory location. The 9 MSBs of the data-memory address of the memory-mapped register are cleared, regardless of the current value of DP or the upper 9 bits of AR(ARP).
SOVM	√	√	√	√	Set Overflow Mode Set the OVM status bit to 1; this enables overflow mode. (The ROVM instruction clears OVM.)
SPAC	√	√	√	√	Subtract P Register From Accumulator Subtract the contents of the P register from the contents of the accumulator. TMS320C2x, TMS320C2xx, and TMS320C5x devices: Before the subtraction, shift the contents of the P register as specified by the PM status bits.
SPH <i>dma</i> SPH { <i>ind</i> } [, <i>next ARP</i>]		√ √	√ √	√ √	Store High P Register Store the high-order bits of the P register (shifted as specified by the PM status bits) at the addressed data-memory location.
SPL <i>dma</i> SPL { <i>ind</i> } [, <i>next ARP</i>]		√ √	√ √	√ √	Store Low P Register Store the low-order bits of the P register (shifted as specified by the PM status bits) at the addressed data-memory location.
SPLK #lk, <i>dma</i> SPLK #lk, { <i>ind</i> } [, <i>next ARP</i>]			√	√ √	Store Parallel Long Immediate Write a full 16-bit pattern into a memory location. The parallel logic unit (PLU) supports this bit manipulation independently of the ALU, so the accumulator is unaffected.
SPM <i>2-bit constant</i>		√	√	√	Set P Register Output Shift Mode Copy a 2-bit immediate value into the PM field of ST1. This controls shifting of the P register as shown below: PM = 00 ₂ Multiplier output is not shifted. PM = 01 ₂ Multiplier output is left shifted one place and zero filled. PM = 10 ₂ Multiplier output is left shifted four places and zero filled. PM = 11 ₂ Multiplier output is right shifted six places and sign extended; the LSBs are lost.

Syntax	1x	2x	2xx	5x	Description
SQRA <i>dma</i> SQRA { <i>ind</i> } [, <i>next ARP</i>]		√	√	√	Square and Accumulate Previous Product Add the contents of the P register (shifted as specified by the PM status bits) to the accumulator. Then load the contents of the addressed data-memory location into the T register (TMS320C2x/2xx) or TREG0 (TMS320C5x), square the value, and store the result in the P register.
SQRS <i>dma</i> SQRS { <i>ind</i> } [, <i>next ARP</i>]		√	√	√	Square and Subtract Previous Product Subtract the contents of the P register (shifted as specified by the PM status bits) to the accumulator. Then load the contents of the addressed data-memory location into the T register (TMS320C2x/2xx) or TREG0 (TMS320C5x), square the value, and store the result in the P register.
SST <i>dma</i> SST { <i>ind</i> } [, <i>next ARP</i>]	√	√	√	√	Store Status Register Store the contents of the ST (TMS320C1x) or ST0 (TMS320C2x/2xx/5x) in the addressed data-memory location.
SST # <i>n</i> , <i>dma</i> SST # <i>n</i> , { <i>ind</i> } [, <i>next ARP</i>]			√	√	Store Status Register n Store ST <i>n</i> in data memory.
SST1 <i>dma</i> SST1 { <i>ind</i> } [, <i>next ARP</i>]		√	√	√	Store Status Register ST1 Store the contents of ST1 in the addressed data-memory location.
SSXM		√	√	√	Set Sign-Extension Mode Set the SXM status bit to 1; this enables sign extension.
STC		√	√	√	Set Test/Control Flag Set the TC flag to 1.
STXM		√			Set Serial Port Transmit Mode Set the TXM status bit to 1.

Syntax	1x	2x	2xx	5x	Description
SUB <i>dma</i> [, <i>shift</i>] SUB { <i>ind</i> } [, <i>shift</i> [, <i>next ARP</i>]] SUB # <i>k</i> SUB # <i>k</i> [, <i>shift</i> ₂]	√	√	√	√	Subtract From Accumulator With Shift TMS320C1x and TMS320C2x devices: Subtract the contents of the addressed data-memory location from the accumulator. If a shift is specified, left shift the value before subtracting. During shifting, low-order bits are zero filled, and high-order bits are sign extended if SXM = 1. TMS320C2xx and TMS320C5x devices: Subtract the contents of the addressed data-memory location or an 8- or 16-bit constant from the accumulator. If a shift is specified, left shift the data before subtracting. During shifting, low-order bits are zero filled, and high-order bits are sign extended if SXM = 1.
SUBB <i>dma</i> SUBB { <i>ind</i> } [, <i>next ARP</i>]		√	√	√	Subtract From Accumulator With Borrow Subtract the contents of the addressed data-memory location and the value of the carry bit from the accumulator. The carry bit is affected in the normal manner.
SUBC <i>dma</i> SUBC { <i>ind</i> } [, <i>next ARP</i>]	√	√	√	√	Conditional Subtract Perform conditional subtraction. SUBC can be used for division.
SUBH <i>dma</i> SUBH { <i>ind</i> } [, <i>next ARP</i>]	√	√	√	√	Subtract From High Accumulator Subtract the contents of the addressed data-memory location from the 16 MSBs of the accumulator. The 16 LSBs of the accumulator are not affected.
SUBK # <i>k</i>		√	√	√	Subtract From Accumulator Short Immediate Subtract an 8-bit immediate value from the accumulator. The data is treated as an 8-bit positive number; sign extension is suppressed.
SUBS <i>dma</i> SUBS { <i>ind</i> } [, <i>next ARP</i>]	√	√	√	√	Subtract From Low Accumulator With Sign Extension Suppressed Subtract the contents of the addressed data-memory location from the accumulator. The data is treated as a 16-bit unsigned number; sign extension is suppressed.

Syntax	1x	2x	2xx	5x	Description
SUBT <i>dma</i> SUBT { <i>ind</i> } [, <i>next ARP</i>]		√	√	√	Subtract From Accumulator With Shift Specified by T Register Left shift the data-memory value as specified by the 4 LSBs of the T register (TMS320C2x/2xx) or TREG1 (TMS320C5x), and subtract the result from the accumulator. If a shift is specified, left shift the data-memory value before subtracting. During shifting, low-order bits are zero filled, and high-order bits are sign extended if SXM = 1.
SXF		√	√	√	Set External Flag Set the XF pin and the XF status bit to 1.
TBLR <i>dma</i> TBLR { <i>ind</i> } [, <i>next ARP</i>]	√	√	√	√	Table Read Transfer a word from program memory to a data-memory location. The program-memory address is in the 12 (TMS320C1x) or 16 (TMS320C2x/2xx/5x) LSBs of the accumulator.
TBLW <i>dma</i> TBLW { <i>ind</i> } [, <i>next ARP</i>]	√	√	√	√	Table Write Transfer a word from data-memory to a program-memory location. The program-memory address is in the 12 (TMS320C1x) or 16 (TMS320C2x/2xx/5x) LSBs of the accumulator.
TRAP		√	√	√	Software Interrupt The TRAP instruction is a software interrupt that transfers program control to program-memory address 30h (TMS320C2x) or 22h (TMS320C2xx/5x) and pushes the PC + 1 onto the hardware stack. The instruction at address 30h or 22h may contain a branch instruction to transfer control to the TRAP routine. Putting the PC + 1 on the stack enables an RET instruction to pop the return PC.
XC <i>n</i> , <i>cond</i> ₁ [, <i>cond</i> ₂] [, ...]				√	Execute Conditionally Execute conditionally the next <i>n</i> instruction words where $1 \leq n \leq 2$. Not all combinations of conditions are meaningful.

Syntax	1x	2x	2xx	5x	Description
XOR <i>dma</i> XOR { <i>ind</i> } [, <i>next ARP</i>] XOR # <i>lk</i> [, <i>shift</i>]	√	√	√	√	Exclusive-OR With Accumulator TMS320C1x and TMS320C2x devices: Exclusive-OR the contents of the addressed data-memory location with 16 LSBs of the accumulator. The MSBs are not affected. TMS320C2xx and TMS320C5x devices: Exclusive-OR the contents of the addressed data-memory location or a 16-bit immediate value with the accumulator. If a shift is specified, left shift the value before performing the exclusive-OR operation. Low-order bits below and high-order bits above the shifted value are treated as 0s.
XORB				√	Exclusive-OR of ACCB With Accumulator Exclusive-OR the contents of the accumulator with the contents of the ACCB. The results are placed in the accumulator.
XORK # <i>lk</i> [, <i>shift</i>]		√	√	√	Exclusive-OR Immediate With Accumulator With Shift Exclusive-OR a 16-bit immediate value with the accumulator. If a shift is specified, left shift the value before performing the exclusive-OR operation. Low-order bits below and high-order bits above the shifted value are treated as 0s.
XPL [# <i>lk</i> ,] <i>dma</i> XPL [# <i>lk</i> ,] { <i>ind</i> } [, <i>next ARP</i>]				√	Exclusive-OR of Long Immediate or DBMR With Addressed Data-Memory Value If a long immediate value is specified, exclusive OR it with the addressed data-memory value; otherwise, exclusive OR the DBMR with the addressed data-memory value. Write the result back to the data-memory location. The accumulator is not affected.
ZAC	√	√	√	√	Zero Accumulator Clear the contents of the accumulator to 0.
ZALH <i>dma</i> ZALH { <i>ind</i> } [, <i>next ARP</i>]	√	√	√	√	Zero Low Accumulator and Load High Accumulator Clear the 16 LSBs of the accumulator to 0 and load the contents of the addressed data-memory location into the 16 MSBs of the accumulator.

Syntax	1x	2x	2xx	5x	Description
ZALR <i>dma</i> ZALR { <i>ind</i> } [, <i>next ARP</i>]		√	√	√	Zero Low Accumulator, Load High Accumulator With Rounding Load the contents of the addressed data-memory location into the 16 MSBs of the accumulator. The value is rounded by 1/2 LSB; that is, the 15 LSBs of the accumulator (0–14) are cleared and bit 15 is set to 1.
ZALS <i>dma</i> ZALS { <i>ind</i> } [, <i>next ARP</i>]	√	√	√	√	Zero Accumulator, Load Low Accumulator With Sign Extension Suppressed Load the contents of the addressed data-memory location into the 16 LSBs of the accumulator. The 16 MSBs are zeroed. The data is treated as a 16-bit unsigned number.
ZAP				√	Zero the Accumulator and Product Register The accumulator and product register are zeroed. The ZAP instruction speeds up the preparation for a repeat multiply/accumulate.
ZPR				√	Zero the Product Register The product register is cleared.

Program Examples

This appendix provides:

- A brief introduction to the process for generating executable program files.
- Sample programs for implementing simple routines and using interrupts, I/O pins, the timer, and the serial ports.

This appendix is not intended to teach you how to use the software development tools. The following documents cover these tools in detail:

TMS320C1x/C2x/C2xx/C5x Assembly Language Tools User's Guide
(literature number SPRU018)

TMS320C2x/C2xx/C5x Optimizing C Compiler User's Guide
(literature number SPRU024)

TMS320C2xx C Source Debugger User's Guide
(literature number SPRU151)

For more information about these documents and about ordering them, see *Related Documentation From Texas Instruments* on page vi of the Preface.

Topic	Page
C.1 About These Program Examples	C-2
C.2 Shared Program Code	C-5
C.3 Task-Specific Program Code	C-8
C.4 Introduction to Generating Boot Loader Code	C-23

C.1 About These Program Examples

Figure C–1 illustrates the basic process for creating assembly language files and then generating executable files from them:

- 1) Use the 'C2xx assembler to create:
 - ❑ A command file (*c203.cmd* in the figure) that defines address ranges according to the architecture of the particular 'C2xx device
 - ❑ An assembly language program (*test.asm* in the figure)
- 2) Assemble the program. The command shown under Step 2 in the figure generates an object file and a file containing a listing of assembler errors encountered.
- 3) Use the linker to bring together the information in the object file and the command file and create an executable file (*test.out* in the figure). The command shown also generates a map file, which explains how the linker assigned the individual sections in the memory.

Note:

The procedure here applies to the PC™ development environment and is given only as an example.

Figure C–1. Procedure for Generating Executable Files

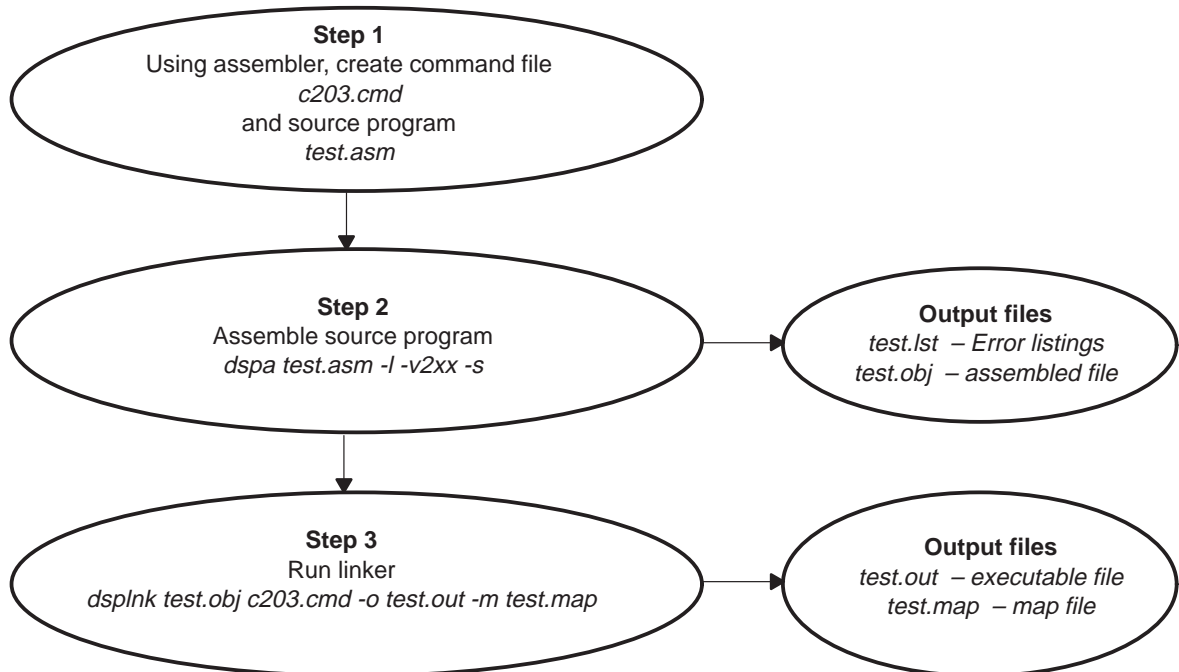

The program examples in Section C.2 and Section C.3 consist of code for shared files and task-specific files. Table C–1 describes the shared programs. Shared files contain code that is used by multiple task-specific files. The task-specific programs are described in Table C–2. Every task-specific file that uses the header files includes them by way of the `.copy` assembler directive:

```
.copy "init.h"
.copy "vector.h"
```

The assembler brings together the `.h` files and `.asm` file. The linker links assembled files according to the device architecture defined in the linker command file (`c203.cmd`).

Section C.4 contains an introduction to the procedure for using the assembler and linker to generate code for the boot loader. Program examples are also given in that section.

Table C–1. Shared Programs in This Appendix

Program	Functional Description	See ...
c203.cmd	Command file that defines size and placement of address blocks for the program, data, and I/O spaces	Example C–1, page C-5
init.h	Header file that declares space for variables and constants; declares initial values for variables; designates labels for the addresses of the control registers mapped to on-chip I/O space; contains comments that explain the functions of the control registers	Example C–2, page C-6
vector.h	Header file that fills the interrupt vector locations with branches to the corresponding interrupt service routines or with other values	Example C–3, page C-7

Table C–2. Task-Specific Programs in This Appendix

Program	Functional Description	See ...
delay.asm	Creates simple nested delay loops, measurable through XF and I/O pins	Example C–4, page C-8
timer.asm	Generates periodic timer interrupt, XF and I/O pins toggle at the interrupt rate	Example C–5, page C-9
intr1.asm	<u>Causes</u> XF pin to toggle at the rate of the interrupt signal on the <u>INT1</u> pin	Example C–6, page C-10
hold.asm	Explains the software logic for implementing a HOLD operation	Example C–7 page C-11
intr23.asm	Accepts an interrupt signal on <u>INT2</u> or <u>INT3</u> . Toggles XF pin for each interrupt.	Example C–8, page C-12

Table C–2. Task-Specific Programs in This Appendix (Continued)

Program	Functional Description	See ...
uart.asm	Causes the asynchronous serial port to transmit a test message continuously at 1200 baud. Baud rate is 1200 at 50-ns cycle time.	Example C–9, page C-13
echo.asm	Echoes the character received by the asynchronous serial port at 1200 baud	Example C–10, page C-14
autobaud.asm	Causes the asynchronous serial port to lock on to the incoming baud rate and echoes the received character. The first character received should be <i>a</i> or <i>A</i> .	Example C–11, page C-16
bitio.asm	Toggles XF bit in response to delta interrupts and sends a character through the asynchronous serial port	Example C–12, page C-18
ssp.asm	Causes the synchronous serial port to send words in continuous mode with internal shift clock and frame synchronization	Example C–13, page C-20
ad55.asm	Implements simple loopback with a TLC320AD55C codec chip interfaced to the synchronous serial port	Example C–14, page C-21

C.2 Shared Program Code

Example C-1. Generic Command File (c203.cmd)

```

/* Title: c203.cmd */
/* Generic command file for linking TMS320C2xx assembler files */
/* input files: *.obj files */
/* output files: *.out file */
/* Map files: *.map file (optional) */
/* TMS320C2xx architecture declaration for linker use */

MEMORY
{
PAGE 0: /* PM - Program memory */

EX1_PM :ORIGIN=0H , LENGTH=0FEFFH /* External program RAM */
B0_PM :ORIGIN=0FF00H, LENGTH=0100H /* BLOCK MAP IN CNF=1 */

PAGE 1: /* DM - Data memory */

REGS :ORIGIN=0H , LENGTH=60H /* MEM-MAPPED REGS */
BLK_B2 :ORIGIN=60H , LENGTH=20H /* BLOCK B2 */
BLK_B0 :ORIGIN=200H , LENGTH=100H /* BLOCK B0 */
BLK_B1 :ORIGIN=300H , LENGTH=100H /* BLOCK B1 */
EX1_DM :ORIGIN=0800H, LENGTH=7800H /* EXTERNAL DATA RAM */
GM_DM :ORIGIN=8000H, LENGTH=8000H /* External DATA RAM AS GLOBAL*/

PAGE 2: /* I/O SPACE */
IO_IN :ORIGIN=0FF00H, LENGTH=0FFH /* I/O MAPPED PERIPHERAL */
IO_EX :ORIGIN=0000H, LENGTH=0FF00H /* EXT. I/O MAPPED PERIPHERAL */

}

SECTIONS
/* Linker directive to specify section placement in the memory map */
{
vectors :{ } > EX1_PM PAGE 0 /* Vectors at 0x0000 */
.text :{ } > EX1_PM PAGE 0 /* .text placed after vectors */
.bss :{ } > EX1_DM PAGE 1 /* .bss in 0x800 in DM */
new :{ } > BLK_B2 PAGE 1 /* new in 0x0060 in DM */
.data :{ } > 0x0370 PAGE 1 /* .data at 0x0370 in DM */
}

```

Example C-2. Header File With I/O Register Declarations (init.h)

```
* File: init.h *
* Include file with I/O register declarations *

        .mmregs                ; Include reserved words
        .bss dmem,10           ; Undefined variables space
        .def ini_d, start,codtx ; Directive for symbol address
                                ; generation in the current module
                                ; -optional
ini_d:   .usect "new",10       ; Example of undefined variable space
                                ; with the segment's name as "new"
        .data                  ; Example of including dummy constants
                                ; -optional
        .word 055aah
        .word 0aa55h

* On-chip register equates
* CLKOUT
clk1     .set 0ffe8h
* INTERRUPT CONTROL
icr      .set 0ffech
* SYNC PORT
sdtr     .set 0fff0h
sspcr    .set 0fff1h
* UART
adtr     .set 0fff4h
aspcr    .set 0fff5h
iosr     .set 0fff6h
brd      .set 0fff7h
* TIMER
tcr      .set 0fff8h
prd      .set 0fff9h
tim      .set 0fffah
* WAIT STATES
wsgr     .set 0fffch

* Variables
rxbuf    .set 0300h
size     .set 00020h
del      .set 0010h
```

Example C–3. Header File With Interrupt Vector Declarations (vector.h)

```
* File:      vector.h                *
* File      defines Interrupt vector labels *
.sect "vectors"
b      start          ; reset vector - Jump to label start on reset
b      inpt1          ; INT1 interrupt
b      inpt23         ; INT2/INT3 interrupt
b      timer          ; TINT Timer interrupt
b      codrx          ; RX_Sync interrupt
b      codtx          ; TX_SYNC interrupt
b      uart           ; TX/RX Uart port interrupt
                ; Reserved and s/w interrupt vector locations
.space 45*16        ; Directive for filling zeros in PM space
.word 1,2,3,4,5     ; Example for constant loading
```

C.3 Task-Specific Program Code

Example C-4. Implementing Simple Delay Loops (*delay.asm*)

```

* File:          delay.asm                                     *
* Function:     Delay loop. XF and I/O 3 pins toggle after each delay *
.               .title "Delay routine" ; Title
.               .copy  "init.h"       ; Variable and register declaration
.               .copy  "vector.h"     ; Vector label declaration
.               .text
start:          clrcc  cnf              ; Map block B0 to data memory
               ldr    #0h             ; set DP=0
               setc  INTM             ; Disable all interrupts
               splk  #0000h, 60h      ; Set zero wait states
               out   60h, wsgcr
               splk  #0e00ch, 60h     ; Define iosr for bit I/O in aspcr
               out   60h, aspcr
               lar   ar0, #del        ; Initialize ar0
               mar   *, ar7           ; Set ARP to ar7
               splk  #0008h, 6eh      ; data for setting bit I/O 3
               splk  #0000h, 6fh      ; data for clearing bit I/O 3
               splk  #0ffffh, 60h     ; Inner repeat loop size
               lar   ar7, #del
loop:           clrcc  xf              ; xf=0
               out   6fh, iosr        ; bit 3=0
dely1:         rpt    60h             ; @ 50ns, this loop gives 3.4 ms approx.
               nop
               banz  dely1, ar7       ; delay = 17*3.4 = 57.8 ms approx.
               lar   ar7, #del
               setc  xf              ; xf=1
               out   6eh, iosr        ; bit 3=1
dely2:         rpt    60h             ; @ 50ns, this loop gives 3.4 ms approx.
               nop
               banz  dely2, ar7       ; delay = 17*3.4 = 57.8 ms approx.
               lar   ar7, #del
               b     loop
inpt1:         ret                    ; Unused interrupts
inpt23:        ret                    ; have dummy returns for safety
timer:         ret
uart:          ret
codtx:         ret
codrx:         ret
               .end                  ; Assembler module end directive -optional

```

Example C-5. Testing and Using the Timer (timer.asm)

```

* File: timer.asm *
* Function: Timer test code *
* PRD=0x00ff,TDDR=f @ 50ns, gives an interrupt interval=205us *
* PRD=0xffff,TDDR=0 @ 50ns, gives an interrupt interval=3.27ms*
* Timer interval measurable on I/O 2,3 or xf pins *

        .title "Timer Test"      ; Title
        .copy "init.h"          ; Variable and register declaration
        .copy "vector.h"       ; Vector label declaration
        .text

start:   clrcc CNF                ; Map block B0 to data memory
        ldp #0h                 ; set DP=0
        setc INTM               ; Disable all interrupts
        splk #0000h,60h         ;
        out 60h, wsgcr          ; Set zero wait states
        splk #0ffffh,ifr        ; clear interrupts
        splk #0004h,imr         ; enable timer interrupt
        splk #0e00ch, 60h       ; configure bit I/O I03 and IO2 as outputs
        out 60h, aspcr          ; set the aspcr for the above
        mar *,ar1
        lar ar1,#rxbuf
        splk #0004h,61h         ; bit value to set I/O 2
        splk #0008h,62h         ; bit value to set I/O 3
        out 61h,iosr           ; set the bit 2 = high, 3= zero
        splk #0000h, 63h
        splk #00ffh, 64h
        out 64h, prd           ; set PRD=0x00ffh
        out 63h, tim           ; set TIM=0x0000
        splk #0c2fh, 64h       ; PSC, TDDR are zero, reload, restart
        out 64h, tcr
        clrcc intm
        clrcc xf
wait:   out 62h,iosr           ; set io2=0
        idle
        clrcc xf
        b wait
timer:  setc xf                 ; xf =1
        in 68h,tcr             ; Read tcr,prd, tim regs.
        in 69h,prd
        in 6ah,tim
        out 61h,iosr          ; set io2=1
        clrcc intm
        ret
inpt1:  ret                    ; Unused interrupt routines
inpt23: ret
codtx:  ret
codrx:  ret
uart:   ret
        .end                   ; Assembler module end directive -optional

```

Example C-6. Testing and Using Interrupt $\overline{INT1}$ (intr1.asm)

```

* File:    intr1.asm                                     *
* Function: Interrupt test code                         *
* For each INT1 interrupt XF,I/O pins IO3 and IO2 will toggle and *
* transmit char 'c' through UART                       *
*
        .title "Interrupt 1 Test" ; Title
        .copy  "init.h"          ; Variable and register declaration
        .copy  "vector.h"       ; Vector label declaration
        .text
start:   clrc  CNF                ; Map block B0 to data memory
        ldp   #0h                ; set DP=0
        setc  INTM              ; Disable all interrupts
        splk  #0ffffh, ifr       ; clear interrupts
        splk  #0001h, imr        ; Enable int1 interrupts
        splk  #0010h, 60h       ;
        out   60h, icr          ; Enable Intr1 in mode bit/ICR
        splk  #0000h, 60h       ;
        out   60h, wsgr         ; Set zero wait states
        splk  #0e00ch, 60h      ; configure IO3 and IO2 as outputs
        out   60h, aspcr        ; set the aspcr for the above
        splk  #0411h, 60h       ; default baud rate 1200, for UART @50 ns
        out   60h, brd          ;
        mar   *, ar1           ; Initialize AR pointer with AR1
        lar   ar1, #rxbuf
        lar   ar0, #size        ; set counter limit
        splk  #0004h, 61h       ; set bit I/O 2
        splk  #0008h, 62h       ; set bit I/O 3
        splk  #0063h, 63h       ; set tx data
        clrc  INTM
        clrc  XF
wait:    out   61h, iosr         ; toggle IO2/3
        idle
        clrc  XF                ; toggle xf
        b     wait
inpt1:   in    65h, icr         ; Read icr
        out   62h, iosr         ; toggle IO2/3
        out   65h, adrx        ; send icr value through UART to check
        ; interrupt source
        setc  XF                ; toggle xf
        clrc  INTM
        ret
timer:   ret
inpt23:  ret
uart:    ret
codtx:   ret
codrx:   ret
        .end                    ; Assembler module end directive
        ; -optional

```

Example C-7. Implementing a HOLD Operation (hold.asm)

```

* File:          hold.asm                                *
* Function:     HOLD test code                          *
* Check for HOLDA toggle for HOLD requests in MODE 0   *
* Check for XF toggle on HOLD/INT1 requests in MODE 1   *
*
        .title " HOLD Test "      ; Title
        .mmregs
icr      .set    0FFECh            ; Interrupt control register in I/O space
icrshdw  .set    060h             ; scratch pad location

* Interrupt vectors
        .text
reset    B      main              ; 0-reset , Branch to main program on reset
intlh   B      intl_hold         ; 1-external interrupt 1 or HOLD
        .space 40*16

*****Interrupt service routine ISR for HOLD logic*****

main:    splk   #0001h,imr
        clrc   intm
wait:    b      wait
intl_hold:
        ; Perform any desired context save
        ldp   #0
        in    icrshdw, icr        ; save the contents of ICR register
        lacl  #010h              ; load ACC with mask for MODE bit
        and   icrshdw            ; Filter out all bits except MODE bit
        bcnd  intl,neq          ; Branch if MODE bit is 1, else in HOLD mode
        lacc  imr, 0             ; load ACC with interrupt mask register
        splk  #1, imr           ; mask all interrupts except interrupt1/HOLD
        idle  ; enter HOLD mode, issues HOLDA
        ; and the busses will be in tristate
        splk  #1, ifr           ; Clear HOLD/INT1 flag to prevent
        ; re-entering HOLD mode
        sacl  imr               ; restore interrupt mask register
        ; Perform necessary context restore

        clrc  intm              ; enable all interrupts
        ret   ; return from HOLD interrupt

intl:    nop                    ; Replace this with desired INT1 interrupt
        nop                    ; service routine
        setc  xf                ; Dummy toggle to check the loop entry
        clrc  xf                ; in MODE 1
        splk  #0001,ifr
        clrc  intm              ; enable all interrupts
        ret   ; return from interrupts

```

Example C-8. Testing and Using Interrupts $\overline{INT2}$ and $\overline{INT3}$ (intr23.asm)

```

* File:      intr23.asm                                     *
* Function:  Interrupt test code                           *
* Interrupt on INT2 or INT3 will toggle IO3 and IO2 bits  *
* and icr value copied in the Buffer @300                  *
*
        .title " Interrupt 2/3 Test" ; Title
        .copy "init.h"               ; Variable and register declaration
        .copy "vector.h"             ; Vector label declaration
        .text
start:   clrc CNF                      ; Map block B0 to data memory
        ldp #0h                       ; set DP=0
        setc INTM                     ; Disable all interrupts
        splk #0ffffh, ifr             ; clear interrupts
        splk #0002h, imr              ; Enable int1 interrupts
        splk #0003h, 60h             ; Enable Int2 and 3 in ICR
        out 60h, icr                  ; Enable Int2 and 3 in ICR
        splk #0000h, 60h             ; Set zero wait states
        out 60h, wsgr                 ; Set zero wait states
        splk #0e00ch, 60h            ; configure the IO3 and IO2 as outputs
        out 60h, aspcr                ; set the aspcr for the above
        mar *, ar1                    ; ARP=ar1
        lar ar1, #rxbuf               ; set counter limit
        lar ar0, #size                ; set counter limit
        splk #0004h, 61h              ; set bit I/O 2
        splk #0008h, 62h              ; set bit I/O 3
        splk #0063h, 63h              ; set tx data
        clrc intm
        clrc xf
wait:    out 61h, iosr                 ; toggle I/O 2
        idle
        clrc xf                       ; toggle xf bit
        b wait
inpt23:  in 65h, icr                   ; Read icr
        in *, icr                      ; Capture icr in buffer @300
        mar *, ar0
        banz skip, ar1
        lar ar1, #rxbuf
        lar ar0, #size
skip:    out 62h, iosr                 ; toggle IO2/3
        setc xf                       ; toggle xf
        out 65h, icr                   ; clear interrupt 2/3 flag bit
        clrc intm
        ret
timer:   ret
inpt1:   ret
uart:    ret
codtx:   ret
codrx:   ret
        .end                          ; Assembler module end directive
                                           ; -optional

```

Example C-9. Asynchronous Serial Port Transmission (uart.asm)

```

* File:    uart.asm                                     *
* Function: UART Test Code                             *
* Continuously sends 'C203 UART is fine' at 1200 baud. *
*
        .title " UART Test"           ; Title
        .copy "init.h"                ; Variable and register declaration
        .copy "vector.h"              ; Vector label declaration
        .text
start:   clrcc CNF                     ; Map block B0 to data memory
        ldp  #0h                       ; set DP=0
        setc INTM                      ; Disable all interrupts

* UART initialization *
        splk #0ffffh,ifr               ; clear interrupts
        splk #0000h,60h
        out  60h, wsgcr                 ; Set zero wait states
        splk #0c180h,61h               ; reset the UART by writing 0
        out  61h, aspcr                 ; 1 stop bit, tx interrupt, input i/o
        splk #0e180h,61h               ; Enable the serial port
        out  61h, aspcr
        splk #4ffffh,62h
        out  62h, iosr                  ; disable auto baud
        splk #0411h, 63h                ; set baud rate =1200 @ 20-MHz CLKOUT1
        out  63h, brd
        splk #20h, imr                  ; enable UART interrupt
        mar  *, ar1                     ; ARP=ar1
        lar  ar1, #rxbuf

* Load data at DM300                               ; 'c203 UART is fine!' - xmit data
        splk #0063h, *+                  ; ascii value for the above characters
        splk #0032h, *+
        splk #0030h, *+
        splk #0033h, *+
        splk #0020h, *+

        splk #0055h, *+
        splk #0041h, *+
        splk #0052h, *+
        splk #0054h, *+
        splk #0020h, *+

        splk #0069h, *+
        splk #0073h, *+
        splk #0020h, *+

        splk #0066h, *+
        splk #0069h, *+
        splk #006eh, *+
        splk #0065h, *+
        splk #0020h, *+
        splk #0021h, *+
        splk #0021h, *+
        splk #0020h, *+

```

Example C-9. Asynchronous Serial Port Transmission (uart.asm) (Continued)

```

        lar    ar1,#rxbuf
        lar    ar0, #20           ; load buffer size
        mar    *,ar1             ; load data pointer
wait:   clrcc intm
        clrcc xf                 ; toggle xf bit
        idle
        b     wait

uart:   setcc  xf                 ; toggle xf bit
        splk  #0ffffh,67h
        out   *,adtr             ; transmit character from data buffer@300
        mar   *,ar0
        banz  skip,ar1           ; check if size=0, and reload
        lar   ar1,#rxbuf
        lar   ar0,#20           ; set size = character length
skip:   splk  #0020h,ifr         ; Clear ifr bit
        clrcc intm
        ret
inpt1:  ret
inpt23: ret
timer:  ret
codtx:  ret
codrx:  ret
        .end                    ; Assembler module end directive
                                   ; -optional

```

Example C-10. Loopback to Verify Transmissions of Asynchronous Serial Port (echo.asm)

```

* File:      echo.asm           *
* Function:  UART Test Code     *
*           Continuously echoes data received by UART at 1200 baud. *
*           Received data will be stored in the buffer @300 *
*
        .title " UART/ASP loop back" ; Title
        .copy  "init.h"              ; Variable and register declaration
        .copy  "vector.h"           ; Vector label declaration
        .text
start:   clrcc CNF                   ; Map block B0 to data memory
        ldp   #0h                   ; set DP=0
        setc  INTM                   ; Disable all interrupts

```

Example C-10. Loopback to Verify Transmissions of Asynchronous Serial Port (echo.asm)
(Continued)

```

* UART initialization *
    splk    #0ffffh,ifr                ; clear interrupts
    splk    #0000h,60h
    out     60h,wsgr                    ; Set zero wait states
    splk    #0c080h,61h                ; reset the UART by writing 0
    out     61h,aspcr                  ; 1 stop bit, rx interrupt, input i/o
    splk    #0e080h,61h
    out     61h,aspcr
    splk    #4ffffh,62h
    out     62h,iosr                    ; disable auto baud
    splk    #0411h,63h                 ; set baud rate =1200 @ 20MHz CLKOUT1
    out     63h,brd
    splk    #20h,imr                    ; enable UART interrupt
    mar     *,ar1

* Load data at DM300
    lar     ar1,#rxbuf
    lar     ar0,#size
    mar     *,ar1                       ; load data pointer
    clrc   intm

wait:   clrc   xf                       ; toggle xf bit
        idle
        b     wait

uart:   setc   xf                       ; toggle xf bit
        ; Check receive flag bit in iosr
        in    68h,iosr                  ; load input status from iosr
        bit   68h,7                     ; bit 8 in the data
        bcnd  skip,ntc                  ; IF DR=0 no echo, return
        in    *,adtr                     ; read and save at 300h
        out   *+,adtr                    ; echo
        mar   *,ar0
        banz  skip,ar1                   ; check if size=0, and reload
        lar   ar1,#rxbuf
        lar   ar0,#size

skip:   splk   #0020h,ifr                ; Clear interrupt in ifr!
        clrc  intm
        ret

inpt1:  ret
inpt23: ret
timer:  ret
codtx:  ret
codrx:  ret
        .end                            ; Assembler module end directive
                                           ; -optional

```

Example C-11. Testing and Using Automatic Baud-Rate Detection on Asynchronous Serial Port (autobaud.asm)

```

* File:          autobaud.asm                      *
* Function:     UART,auto baud test                *
*              Locks to incoming baud rate if the first character *
*              is "A" or "a" & continuously echoes data received *
*              through the port.                   *
*
* Once detection is complete, if the CAD and ADC bits are not *
* disabled and the interrupt is enabled, the ISR will occur for *
* all characters received and will change the baud setting again. *

        .title "Auto_baud detect" ; Title
        .copy "init.h"           ; Variable and register declaration
        .copy "vector.h"        ; Vector label declaration
        .text

start:   clrcc   CNF                ; Map block B0 to data memory
        ldp    #0h                 ; set DP=0
        setc   INTM               ; Disable all interrupts

* UART initialization *
        splk   #0ffffh,ifrr        ; clear interrupts
        splk   #0000h,60h         ;
        out    60h,wsgr            ; Set zero wait states
        splk   #0c0a0h,61h        ; reset the UART by writing 0
        out    61h,aspcr          ; 1 stop bit, rx interrupt, input i/o
        splk   #0e0a0h,61h        ; CAD=1 enable
        out    61h,aspcr          ;
        splk   #4ffffh,62h        ; enable ADC bit
        out    62h,iosr           ; disable auto baud
        splk   #0000h,63h         ; set baud rate =0000 @ 20-MHz CLKOUT1
        out    63h,brd            ;
        splk   #20h,imr           ; enable UART interrupt
        mar    *,ar1              ;
        lar    ar1,#rxbuf         ;

* Load data at DM300
        lar    ar1,#rxbuf         ;
        lar    ar0,#size          ; load buffer size
        mar    *,ar1             ; load data pointer
        clrcc intm               ;
wait:   clrcc  xf                 ;
        idle
        b     wait

```

Example C–11. Testing and Using Automatic Baud-Rate Detection on Asynchronous Serial Port (autobaud.asm) (Continued)

```

uart:
    setc    xf
    in     68h,iosr           ; load input status from iosr
    bit    68h,1             ; check if auto baud bit is set
    bcnd   rcv,ntc           ; branch normal receive
    splk   #4fffh,67h        ; clear ADC
    out    67h,iosr
    splk   #0e080h,67h
    out    67h, aspcr        ; Disable CAD bit/auto baud
rcv:
    in     68h,iosr           ; check for DR bit
    bit    68h,7             ; bit 8 in the data
    bcnd   skip,ntc         ; IF DR=0 no echo, return
    in     *,adtr             ; read and save at 300h
    out    *,adtr            ; echo
    mar    *,ar0
    banz   skip,ar1          ; check if size=0, and reload
    lar    ar1,#rxbuf
    lar    ar0,#size
skip:
    splk   #0020h,ifr        ; Clear ifr
    clrc   intm
    ret
inpt1:   ret
inpt23:  ret
timer:   ret
codtx:   ret
codrx:   ret
        .end                ; Assembler module end directive
                                ; -optional

```

Example C-12. Testing and Using Asynchronous Serial Port Delta Interrupts (bitio.asm)

```

* File:          bitio.asm                                *
* Function:     Delta interrupt test code                *
*              Accepts delta interrupt on IO pins 3 and 2 *
*              If bit level changes on bit 7, send character 'c' *
*              through UART & toggle xf pin.            *
*              If bit level changes on bit 6, send character 'i' *
*              through UART & toggle xf pin.            *
*              The delta bits are cleared after interrupt service *

        .title "BIT IO Interrupt Test" ; Title
        .copy  "init.h"                ; Variable and register declaration
        .copy  "vector.h"              ; Vector label declaration
        .text

start:   clrcc   CNF                    ; Map block B0 to data memory
        ldp    #0h                      ; set DP=0
        setc   INTM                     ; Disable all interrupts

* UART initialization *
        splk   #0ffffh,ifr              ; clear interrupts
        splk   #0000h,60h
        out    60h,wsgr                  ; Set zero wait states
        splk   #0c200h,61h              ; reset the UART by writing 0
        out    61h,aspcr                 ; 1 stop bit, Delta interrupt,
        ; input i/o

        splk   #0e200h,61h
        out    61h,aspcr
        splk   #4ffffh,62h
        out    62h,iosr                  ; disable auto baud
        splk   #0411h, 63h              ; set baud rate =1200 @ 20-MHz CLKOUT1
        out    63h,brd
        splk   #20h,imr                  ; enable UART interrupt
        splk   #0063h,65h                ; transmit value = 0063h ='c'
        splk   #0069h,67h                ; transmit value = 0063h ='i'
        mar    *,ar1
        lar    ar1,#rxbuf

* Load data at DM300 *
        lar    ar1,#rxbuf
        lar    ar0, #size                 ; load buffer size
        mar    *,ar1                     ; load data pointer
        clrcc   intm                     ; disable interrupts for polling

wait:   idle
        b      wait

```

Example C-12. Testing and Using Asynchronous Serial Port Delta Interrupts(bitio.asm)
(Continued)

```

uart:   setc   xf                ; toggle xf bit
        in    68h,iosr          ; Bit i/o check
        bit   68h,8             ; bit address 7 I/O 3 BIT IS SET?
                                   ; required bit place = complement 7 !
        bcnd  poll,ntc          ; NO then check FOR I/O 2
        clrc  tc
        out   65h, adtr          ; transmit 63h = 'c'
        splk  #0080h,6bh        ; reset delta bit
        out   6bh,iosr          ; THE DELTA INTERRUPTS WILL BE ALWAYS
                                   ; COMING IF THIS IS NOT CLEARED!!!
        clrc  xf                ; clear xf bit
        splk  #20h,ifr          ; clear ifr bits
        clrc  intm
        ret
poll:   in    68h,iosr          ; bit address 6 I/O 2 bit is set?
        bit   68h,9
        bcnd  poll1,ntc
        clrc  tc
        out   67h, adtr          ; if set transmit 69h = 'i'
        splk  #0040h,6bh        ; reset delta bit
        out   6bh,iosr
poll1:  clrc  xf                ; clear xf bit
        splk  #20h,ifr          ; clear ifr bits
        clrc  intm
        ret
inpt1:  ret
inpt23: ret
timer:  ret
codtx:  ret
codrx:  ret
        .end                    ; Assembler module end directive
                                   ; -optional

```

Example C-13. Synchronous Serial Port Continuous Mode Transmission (ssp.asm)

```

* File:          ssp.asm                      *
* Function:     Continuous transmit in CONTINUOUS mode *
*              Internal shift clock and frame sync   *
*              Transmit FIFO level is set to 4      *
;
; .title "SSP Continuous mode" ; Title
; .copy "init.h" ; Variable and register declaration
; .copy "vector.h" ; Vector label declaration
; .text
start:  clrc  cnf ; Map block B0 to data memory
        ldp  #0h ; set DP=0
        setc INTM ; Disable all interrupts
        splk #0000h, 60h ; Set zero wait states
        out  60h, wmgr
        splk #0cc0ch, 60h ; reset the serial port by writing
        out  60h, sspcr ; zeros at NOR/RES
        splk #0cc3ch, 60h ; enable Sync port, 4 word fifo,
        out  60h, sspcr ; internal clocks, Continuous mode
                          ; Use sspcr= #0cc3eh for Burst mode
        splk #1717h, 61h ; dummy data for tx
        splk #7171h, 63h
        splk #0aa55h, 64h
        splk #55aah, 62h ; transmit 55aah on tx
        splk #10h, imr ; enable xinit interrupt
        clrc intm ; enable INTM
        out  62h, sdtr ; Xmit once to start
        out  61h, sdtr ; transmit interrupts
        out  63h, sdtr
        out  64h, sdtr

loop:   clrc  xf ; clear xf flag
        idle
        b    loop

codtx:  setc  xf ; set xf bit
        out  62h, sdtr ; transmit 0x55aah again
        out  61h, sdtr ; transmit 1717h
        out  63h, sdtr ; transmit 7171h
        out  64h, sdtr ; transmit aa55h
        splk #0010h, ifr ; clear ifr flag
        clrc intm
        ret

codrx:  ret
inpt1:  ret
inpt23: ret
timer:  ret
uart:   ret
        .end ; Assembler module end directive
; -optional

```

Example C-14. Using Synchronous Serial Port With Codec Device (ad55.asm)

```

* File:          ad55.asm                                     *
* Function:      Burst mode simple loop back on AD55 CODEC   *
*               CODEC master clock 10 MHz                   *
*               Simple I/O at 9.6-kHz sampling               *
*
        .title "AD55 codec simple I/O" ; Title
        .copy "init.h"                ; Variable and register declaration
        .copy "vector.h"              ; Vector label declaration
        .text
start:   clrc   cnf                    ; Map block B0 to data memory
        ldp    #0h                     ; set DP=0
        setc   intm                    ; Disable all interrupts
        splk   #0000h, 60h             ; Set zero wait states
        out    60h, wsgcr
        splk   #0c002h, 60h           ; Initialize SSP
        out    60h, sspcr              ; reset the serial port by writing
        splk   #0c032h, 60h           ; zeros to reset bits,
        out    60h, sspcr              ; enable Sync port, 1 word fifo,
                                        ; CLX/FSR as inputs. Burst mode

main:    splk   #08h, imr                ; enable RINT interrupt
        splk   #0ffffh, ifr             ; reset ifr flags
        mar    *, ar1                   ; load ar1 with rx buffer
        lar    ar1, #rxbuf
        lar    ar0, #size
* 0      0    R/W'  reg_add  data        ; AD55 command reg. bits
*D15     14   13    12 - 8    7-0
        splk   #0000h, 60h             ; reg0 nop
        splk   #0304h, 61h             ; reg1 8khz sampling
        splk   #0200h, 62h             ; default data 00
        splk   #0301h, 63h             ; default data 01
        splk   #0401h, 64h             ; default data 01
        splk   #0508h, 65h             ; default data 08
        splk   #0001h, 66h             ; secondary comm. request data
        out    66h, sdtr                ; request sec. comm.
        out    61h, sdtr                ; send reg1 data for 9.6-Khz sampling
        out    60h, sdtr                ; send 0x0000 after programming
        clrc   intm                    ; Enable SSP interrupts
loop:    clrc   xf                      ; clear xf flag
        idle   ; Wait for SSP interrupt
        b      loop

```

Example C-14. Using Synchronous Serial Port With Codec Device (ad55.asm)
(Continued)

```
codtx:   splk   #0010h, ifr           ; clear tx intr flag
         clrc   intm
         ret

codrx:   setc   xf                   ; toggle xf bit
         in     *,sdtr                ; Read ADC value
         lacc   *,0                   ; Make LSB zero
         and   #0ffffh,0             ; to avoid secondary
         sac1   6ah,0                 ; request for codec
         out   6ah,sdtr              ; Send ADC value to DAC
         mar   *,ar0
         banz  skip,ar1               ; Check buffer limits
         lar   ar1,#rxbuf
         lar   ar0,#size
skip:    splk   #0008h, ifr           ; Clear ifr flag
         clrc   intm
         ret
inpt1:   ret
inpt23:  ret
timer:   ret
uart:    ret
         .end                        ; Assembler module end directive
                                     ; -optional
```

C.4 Introduction to Generating Boot Loader Code

The 'C2xx on-chip boot loader boots software from an 8-bit external EPROM to a 16-bit external RAM at reset. This section introduces to the procedure for using Texas Instruments development tools to generate the code that will be loaded into the EPROM.

Note:

The procedure in this section is given only as an example. This procedure may have to be modified to suit different applications.

For more details, refer to the *TMS320C1x/C2x/C2xx/C5x Assembly Language Tools User's Guide* (literature number SPRU018).

The process for generating boot loader code uses these basic steps:

- 1) Write the following code by using the TMS320C1x/C2x/C2xx/C5x assembler:
 - The code that you wish to have loaded into the EPROM. Program code is listed after a `.text` assembler directive (see any of the programs in Section C.3).
 - A linker command file that defines the architecture of the particular 'C2xx device being used. Example C–15 shows a command file for the 'C203. Note that the file declares the `.text` section at 0000h. This is necessary because the boot loader transfers the code to the external RAM beginning at address 0000h.
- 2) Assemble the code. Use the `-v2xx` option (for 'C2xx assembly) in the assemble command.
- 3) Link the assembled file with the command file by using the TMS320C1x/C2x/C2xx/C5x linker.
- 4) Write a hex conversion command file (an ASCII file) that contains options and directives for the TMS320C1x/C2x/C2xx/C5x hex conversion utility. Example C–16 shows such a file.
- 5) Use the hex conversion command file with the hex conversion utility to generate the boot code in an ASCII hexadecimal format suitable for loading into an EPROM programmer. The command file in Example C–16 selects the Intel™ format.

Example C-15. Linker Command File

```

MEMORY
{
PAGE 0:      /* PM - Program memory */
EX1_PM      :ORIGIN=0H      , LENGTH=0FEFFH /* External program RAM */
B0_PM       :ORIGIN=0FF00H, LENGTH=0100H /* BLOCK MAP IN CNF=1 */
PAGE 1:      /* DM - Data memory */
REGS        :ORIGIN=0H      , LENGTH=60H    /* MEM-MAPPED REGS */
BLK_B2      :ORIGIN=60H     , LENGTH=20H   /* BLOCK B2 */
BLK_B0      :ORIGIN=200H    , LENGTH=100H /* BLOCK B0, */
BLK_B1      :ORIGIN=300H    , LENGTH=100H /* BLOCK B1 */
EX1_DM      :ORIGIN=0800H   , LENGTH=7800H /* EXTERNAL DATA RAM */
GM_DM       :ORIGIN=8000H   , LENGTH=8000H /* External DATA RAM AS GLOBAL */
PAGE 2:      /* I/O SPACE */
IO_IN       :ORIGIN=0FF00H, LENGTH=0FFH /* I/O MAPPED PERIPHERAL */
IO_EX       :ORIGIN=0000H, LENGTH=0FF00H /* EXT. I/O MAPPED PERIPHERAL */
}

SECTIONS
/* Linker directive to specify section placement in the memory map */
{
    .text :{ } > EX1_PM PAGE 0
}

```

Example C-16. Hex Conversion Utility Command File

```

dspdex boot.cmd
/* boot.cmd file an example */
test.out      /* File for boot code in COFF format*/
-i            /* option to generate Intel hex format */
-o test.i0    /* Name of the output file */
-byte        /* 16-bit code is converted into byte */
             /* stack to suit 8-bit ROM. */
-order MS    /* The byte order is higher byte first followed by */
             /* lower order byte */
-memwidth 8
-romwidth 8
-boot
SECTIONS
{ .text:boot }

```

Submitting ROM Codes to TI

The size of a printed circuit board is a consideration in many DSP applications. To make full use of the board space, Texas Instruments offers this ROM code option that reduces the chip count and provides a single-chip solution. This option allows you to use a code-customized processor for a specific application while taking advantage of:

- Greater memory expansion
- Lower system cost
- Less hardware and wiring
- Smaller PCB

If a routine or algorithm is used often, it can be programmed into the on-chip ROM of a TMS320 DSP. TMS320 programs can also be expanded by using external memory; this reduces chip count and allows for a more flexible program memory. Multiple functions are easily implemented by a single device, thus enhancing system capabilities.

TMS320 development tools are used to develop, test, refine, and finalize the algorithms. The microprocessor/microcomputer (MP/MC) mode is available on all ROM-coded TMS320 DSP devices when accesses to either on-chip or off-chip memory are required. The microprocessor mode is used to develop, test, and refine a system application. In this mode of operation, the TMS320 acts as a standard microprocessor by using external program memory. When the algorithm has been finalized, the code can be submitted to Texas Instruments for masking into the on-chip program ROM. At that time, the TMS320 becomes a microcomputer that executes customized programs from the on-chip ROM. Should the code need changing or upgrading, the TMS320 can once again be used in the microprocessor mode. This shortens the field-upgrade time and avoids the possibility of inventory obsolescence.

Figure D-1 illustrates the procedural flow for developing and ordering TMS320 masked parts. When ordering, there is a one-time, nonrefundable charge for mask tooling. A minimum production order per year is required for any masked-ROM device. ROM codes will be deleted from the TI system one year after the final delivery.

Figure D-1. TMS320 ROM Code Submittal Flow Chart

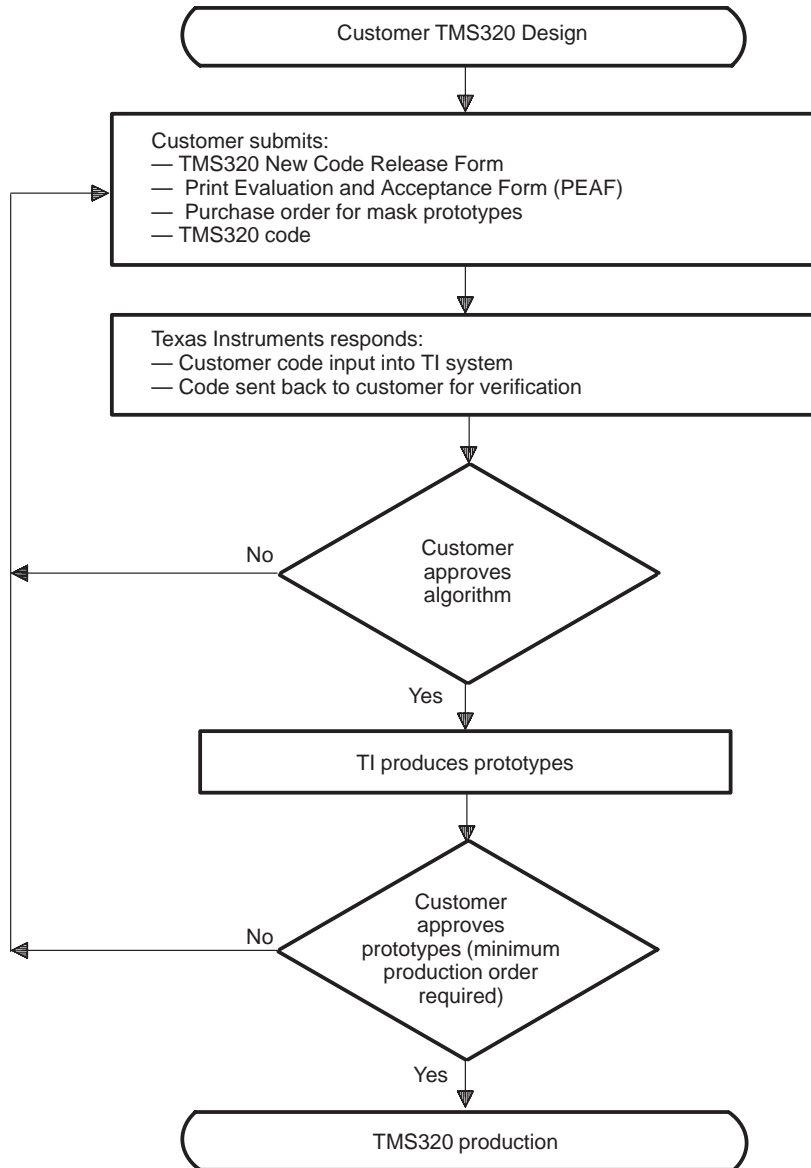

The TMS320 ROM code may be submitted in one of the following forms:

- 5-1/4-in floppy: COFF format from macro-assembler/linker (preferred)
- Modem (BBS): COFF format from macro-assembler/linker
- EPROM (others): TMS27C64
- PROM: TBP28S166, TBP28S86

When code is submitted to TI for masking, the code is reformatted to accommodate the TI mask-generation system. System-level verification by the customer is therefore necessary to ensure the reformatting remains transparent and does not affect the execution of the algorithm. The formatting changes involve the removal of address-relocation information (the code address begins at the base address of the ROM in the TMS320 device and progresses without gaps to the last address of the ROM) and the addition of data in the reserved locations of the ROM for device ROM test. Because these changes have been made, a checksum comparison is not a valid means of verification.

With each masked-device order, the customer must sign a disclaimer that states:

The units to be shipped against this order were assembled, for expediency purposes, on a prototype (that is, nonproduction qualified) manufacturing line, the reliability of which is not fully characterized. Therefore, the anticipated inherent reliability of these prototype units cannot be expressly defined.

and a release that states:

Any masked ROM device may be resymbolized as TI standard product and resold as though it were an unprogrammed version of the device, at the convenience of Texas Instruments.

The use of the ROM-protect feature does not hold for this release statement. Additional risk and charges are involved when the ROM-protect feature is selected. Contact the nearest TI Field Sales Office for more information on procedures, leadtimes, and cost associated with the ROM-protect feature.

Design Considerations for Using XDS510 Emulator

This appendix assists you in meeting the design requirements of the Texas Instruments XDS510 emulator with respect to IEEE-1149.1 designs and discusses the XDS510 cable (manufacturing part number 2617698-0001). This cable is identified by a label on the cable pod marked *JTAG 3/5V* and supports both standard 3-V and 5-V target system power inputs.

The term *JTAG*, as used in this book, refers to TI scan-based emulation, which is based on the IEEE 1149.1 standard.

For more information concerning the IEEE 1149.1 standard, contact IEEE Customer Service:

Address: IEEE Customer Service
 445 Hoes Lane, PO Box 1331
 Piscataway, NJ 08855-1331

Phone: (800) 678–IEEE in the US and Canada
 (908) 981–1393 outside the US and Canada

FAX: (908) 981–9667 Telex: 833233

Topic	Page
E.1 Designing Your Target System’s Emulator Connector (14-Pin Header)	E-2
E.2 Bus Protocol	E-4
E.3 Emulator Cable Pod	E-5
E.4 Emulator Cable Pod Signal Timing	E-6
E.5 Emulation Timing Calculations	E-7
E.6 Connections Between the Emulator and the Target System	E-10
E.7 Physical Dimensions for the 14-Pin Emulator Connector	E-14
E.8 Emulation Design Considerations	E-16

E.1 Designing Your Target System's Emulator Connector (14-Pin Header)

JTAG target devices support emulation through a dedicated emulation port. This port is accessed directly by the emulator and provides emulation functions that are a superset of those specified by IEEE 1149.1. To communicate with the emulator, *your target system must have a 14-pin header* (two rows of seven pins) with the connections that are shown in Figure E-1. Table E-1 describes the emulation signals.

Although you can use other headers, the recommended unshrouded, straight header has these DuPont connector systems part numbers:

- 65610-114
- 65611-114
- 67996-114
- 67997-114

Figure E-1. 14-Pin Header Signals and Header Dimensions

TMS	1	2	TRST
TDI	3	4	GND
PD (V _{CC})	5	6	no pin (key) [†]
TDO	7	8	GND
TCK_RET	9	10	GND
TCK	11	12	GND
EMU0	13	14	EMU1

Header Dimensions:
 Pin-to-pin spacing, 0.100 in. (X,Y)
 Pin width, 0.025-in. square post
 Pin length, 0.235-in. nominal

[†] While the corresponding female position on the cable connector is plugged to prevent improper connection, the cable lead for pin 6 is present in the cable and is grounded, as shown in the schematics and wiring diagrams in this appendix.

Table E–1. 14-Pin Header Signal Descriptions

Signal	Description	Emulator† State	Target† State
EMU0	Emulation pin 0	I	I/O
EMU1	Emulation pin 1	I	I/O
GND	Ground		
PD(V _{CC})	Presence detect. Indicates that the emulation cable is connected and that the target is powered up. PD should be tied to V _{CC} in the target system.	I	O
TCK	Test clock. TCK is a 10.368-MHz clock source from the emulation cable pod. This signal can be used to drive the system test clock.	O	I
TCK_RET	Test clock return. Test clock input to the emulator. May be a buffered or unbuffered version of TCK.	I	O
TDI	Test data input	O	I
TDO	Test data output	I	O
TMS	Test mode select	O	I
$\overline{\text{TRST}}\ddagger$	Test reset	O	I

† I = input; O = output

‡ Do not use pullup resistors on $\overline{\text{TRST}}$: it has an internal pulldown device. In a low-noise environment, $\overline{\text{TRST}}$ can be left floating. In a high-noise environment, an additional pulldown resistor may be needed. (The size of this resistor should be based on electrical current considerations.)

E.2 Bus Protocol

The IEEE 1149.1 specification covers the requirements for the test access port (TAP) bus slave devices and provides certain rules, summarized as follows:

- The TMS and TDI inputs are sampled on the rising edge of the TCK signal of the device.
- The TDO output is clocked from the falling edge of the TCK signal of the device.

When these devices are daisy-chained together, the TDO of one device has approximately a half TCK cycle setup time before the next device's TDI signal. This timing scheme minimizes race conditions that would occur if both TDO and TDI were timed from the same TCK edge. The penalty for this timing scheme is a reduced TCK frequency.

The IEEE 1149.1 specification does not provide rules for bus master (emulator) devices. Instead, it states that the device expects a bus master to provide bus slave compatible timings. The XDS510 provides timings that meet the bus slave rules.

E.3 Emulator Cable Pod

Figure E–2 shows a portion of the emulator cable pod. The functional features of the pod are:

- TDO and TCK_RET can be parallel-terminated inside the pod if required by the application. By default, these signals are not terminated.
- TCK is driven with a 74LVT240 device. Because of the high-current drive (32-mA I_{OL}/I_{OH}), this signal can be parallel-terminated. If TCK is tied to TCK_RET, you can use the parallel terminator in the pod.
- TMS and TDI can be generated from the falling edge of TCK_RET, according to the IEEE 1149.1 bus slave device timing rules.
- TMS and TDI are series-terminated to reduce signal reflections.
- A 10.368-MHz test clock source is provided. You can also provide your own test clock for greater flexibility.

Figure E–2. Emulator Cable Pod Interface

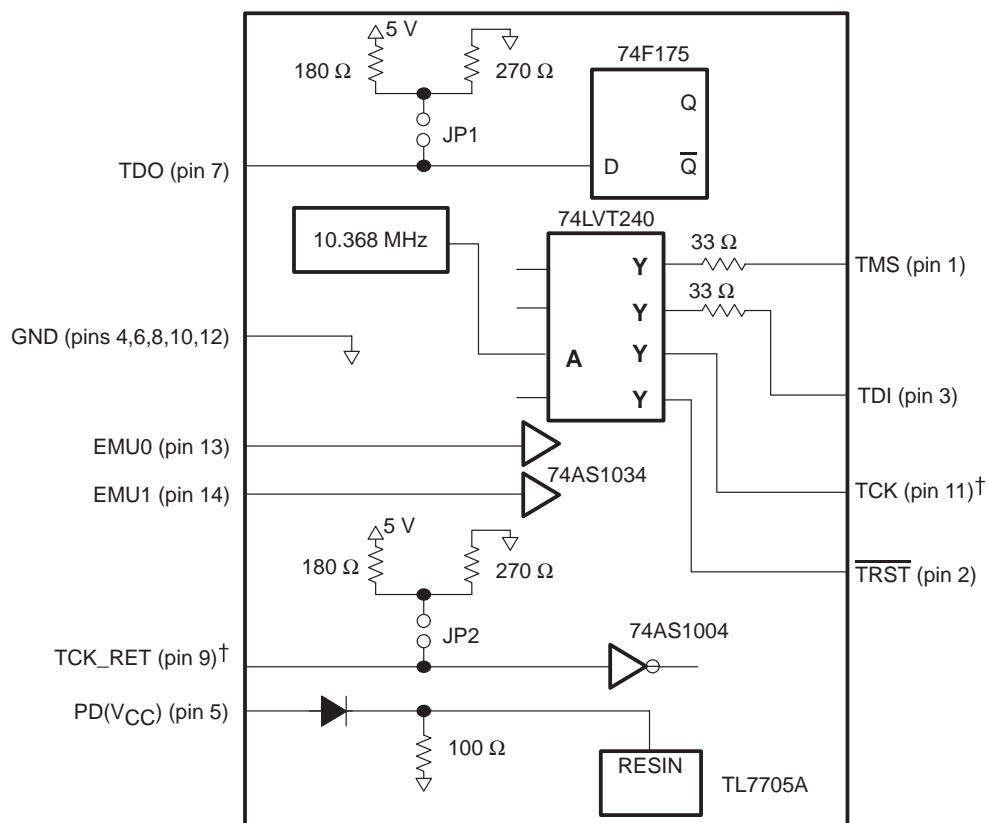

† The emulator pod uses TCK_RET as its clock source for internal synchronization. TCK is provided as an optional target system test clock source.

E.4 Emulator Cable Pod Signal Timing

Figure E-3 shows the signal timings for the emulator cable pod. Table E-2 defines the timing parameters illustrated in the figure. These timing parameters are calculated from values specified in the standard data sheets for the emulator and cable pod and are for reference only. Texas Instruments does not test or guarantee these timings.

The emulator pod uses TCK_RET as its clock source for internal synchronization. TCK is provided as an optional target system test clock source.

Figure E-3. Emulator Cable Pod Timings

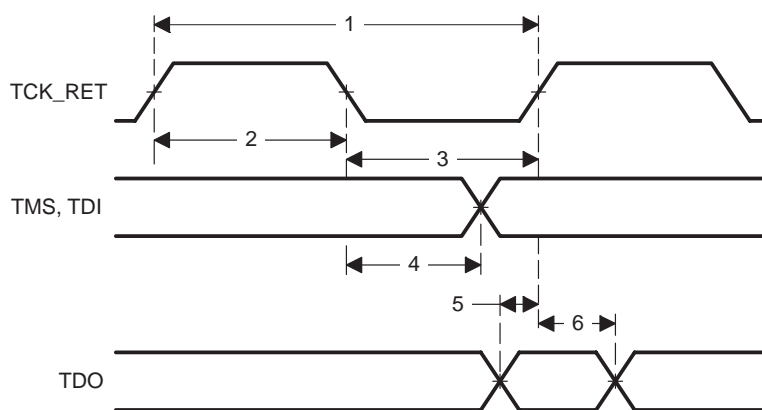

Table E-2. Emulator Cable Pod Timing Parameters

No.	Parameter	Description	Min	Max	Unit
1	$t_c(\text{TCK})$	Cycle time, TCK_RET	35	200	ns
2	$t_w(\text{TCKH})$	Pulse duration, TCK_RET high	15		ns
3	$t_w(\text{TCKL})$	Pulse duration, TCK_RET low	15		ns
4	$t_d(\text{TMS})$	Delay time, TMS or TDI valid for TCK_RET low	6	20	ns
5	$t_{su}(\text{TDO})$	Setup time, TDO to TCK_RET high	3		ns
6	$t_h(\text{TDO})$	Hold time, TDO from TCK_RET high	12		ns

E.5 Emulation Timing Calculations

Example E–1 and Example E–2 help you calculate emulation timings in your system. For actual target timing parameters, see the appropriate data sheet for the device you are emulating.

The examples use the following assumptions:

$t_{su}(TTMS)$	Setup time, target TMS or TDI to TCK high	10 ns
$t_d(TTDO)$	Delay time, target TDO from TCK low	15 ns
$t_d(bufmax)$	Delay time, target buffer maximum	10 ns
$t_d(bufmin)$	Delay time, target buffer minimum	1 ns
$t_{bufskew}$	Skew time, target buffer between two devices in the same package: $[t_d(bufmax) - t_d(bufmin)] \times 0.15$	1.35 ns
$t_{TCKfactor}$	Duty cycle, assume a 40/60% duty cycle clock	0.4 (40%)

Also, the examples use the following values from Table E–2 on page E-6:

$t_d(TMSmax)$	Delay time, emulator TMS or TDI from TCK_RET low, maximum	20 ns
$t_{su}(TDOmin)$	Setup time, TDO to emulator TCK_RET high, minimum	3 ns

There are two key timing paths to consider in the emulation design:

- The TCK_RET-to-TMS or TDI path, called $t_{pd}(TCK_RET-TMS/TDI)$ (propagation delay time)
- The TCK_RET-to-TDO path, called $t_{pd}(TCK_RET-TDO)$

In the examples, the worst-case path delay is calculated to determine the maximum system test clock frequency.

Example E–1. Key Timing for a Single-Processor System Without Buffers

$$\begin{aligned}
 t_{pd}(\text{TCK_RET-TMS/TDI}) &= \frac{[t_{d(\text{TMSmax})} + t_{su(\text{TTMS})}]}{t_{\text{TCKfactor}}} \\
 &= \frac{(20 \text{ ns} + 10 \text{ ns})}{0.4} \\
 &= 75 \text{ ns, or } 13.3 \text{ MHz} \\
 t_{pd}(\text{TCK_RET-TDO}) &= \frac{[t_{d(\text{TTDO})} + t_{su(\text{TDOmin})}]}{t_{\text{TCKfactor}}} \\
 &= \frac{(15 \text{ ns} + 3 \text{ ns})}{0.4} \\
 &= 45 \text{ ns, or } 22.2 \text{ MHz}
 \end{aligned}$$

In this case, because the TCK_RET-to-TMS/TDI path requires more time to complete, it is the limiting factor.

Example E–2. Key Timing for a Single- or Multiple-Processor System With Buffered Input and Output

$$\begin{aligned}
 t_{pd}(\text{TCK_RET-TMS/TDI}) &= \frac{[t_{d(\text{TMSmax})} + t_{su(\text{TTMS})} + t_{bufskew}]}{t_{\text{TCKfactor}}} \\
 &= \frac{(20 \text{ ns} + 10 \text{ ns} + 1.35 \text{ ns})}{0.4} \\
 &= 78.4 \text{ ns, or } 12.7 \text{ MHz} \\
 t_{pd}(\text{TCK_RET-TDO}) &= \frac{[t_{d(\text{TTDO})} + t_{su(\text{TDOmin})} + t_{d(\text{bufmax})}]}{t_{\text{TCKfactor}}} \\
 &= \frac{(15 \text{ ns} + 3 \text{ ns} + 10 \text{ ns})}{0.4} \\
 &= 70 \text{ ns, or } 14.3 \text{ MHz}
 \end{aligned}$$

In this case also, because the TCK_RET-to-TMS/TDI path requires more time to complete, it is the limiting factor.

In a multiprocessor application, it is necessary to ensure that the EMU0 and EMU1 lines can go from a logic low level to a logic high level in less than 10 μs , this parameter is called rise time, t_r . This can be calculated as follows:

$$\begin{aligned}t_r &= 5(R_{\text{pullup}} \times N_{\text{devices}} \times C_{\text{load_per_device}}) \\&= 5(4.7 \text{ k}\Omega \times 16 \times 15 \text{ pF}) \\&= 5(4.7 \times 10^3 \Omega \times 16 \times 15 \times 10^{-12} \text{ F}) \\&= 5(1128 \times 10^{-9}) \\&= 5.64 \mu\text{s}\end{aligned}$$

E.6 Connections Between the Emulator and the Target System

It is extremely important to provide high-quality signals between the emulator and the JTAG target system. You must supply the correct signal buffering, test clock inputs, and multiple processor interconnections to ensure proper emulator and target system operation.

Signals applied to the EMU0 and EMU1 pins on the JTAG target device can be either input or output. In general, these two pins are used as both input and output in multiprocessor systems to handle global run/stop operations. EMU0 and EMU1 signals are applied only as inputs to the XDS510 emulator header.

E.6.1 Buffering Signals

If the distance between the emulation header and the JTAG target device is greater than 6 inches, the emulation signals must be buffered. If the distance is less than 6 inches, no buffering is necessary. Figure E–4 shows the simpler, no-buffering situation.

The distance between the header and the JTAG target device must be no more than 6 inches. The EMU0 and EMU1 signals must have pullup resistors connected to V_{CC} to provide a signal rise time of less than 10 μ s. A 4.7-k Ω resistor is suggested for most applications.

Figure E–4. Emulator Connections Without Signal Buffering

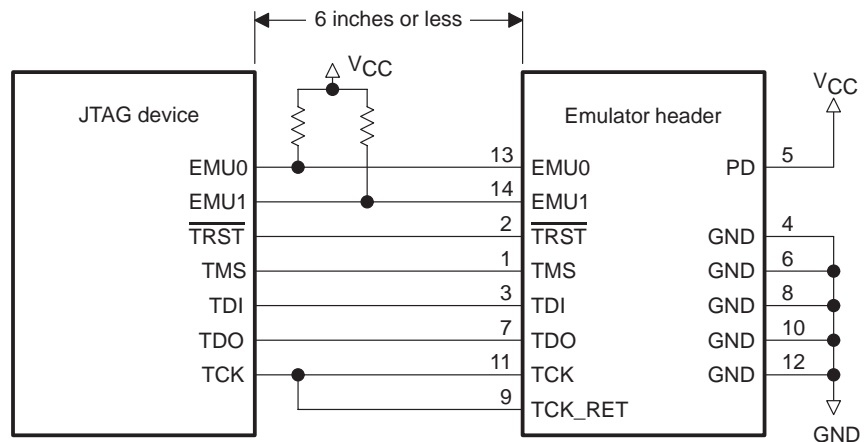
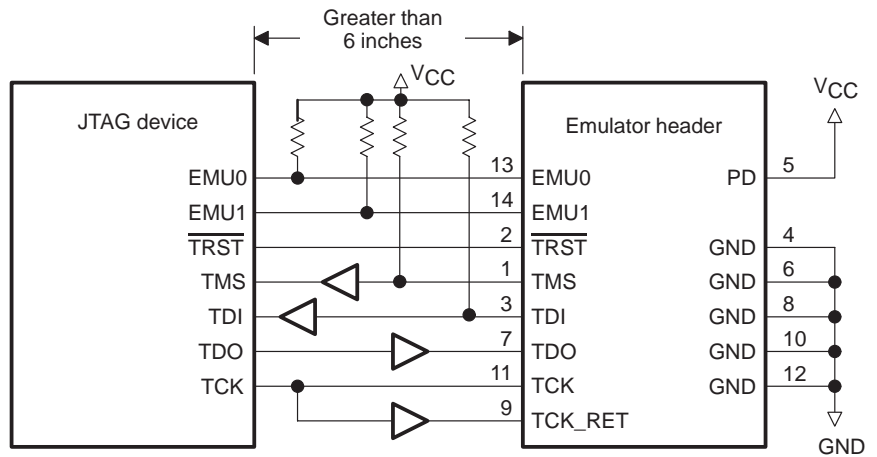

Figure E–5 shows the connections necessary for buffered transmission signals. The distance between the emulation header and the processor is greater than 6 inches. Emulation signals TMS, TDI, TDO, and TCK_RET are buffered through the same device package.

Figure E–5. Emulator Connections With Signal Buffering



The EMU0 and EMU1 signals must have pullup resistors connected to V_{CC} to provide a signal rise time of less than 10 μs . A 4.7-k Ω resistor is suggested for most applications.

The input buffers for TMS and TDI should have pullup resistors connected to V_{CC} to hold these signals at a known value when the emulator is not connected. A resistor value of 4.7 k Ω or greater is suggested.

To have high-quality signals (especially the processor TCK and the emulator TCK_RET signals), you may have to employ special care when routing the printed wiring board trace. You also may have to use termination resistors to match the trace impedance. The emulator pod provides optional internal parallel terminators on the TCK_RET and TDO. TMS and TDI provide fixed series termination.

Because $\overline{\text{TRST}}$ is an asynchronous signal, it should be buffered as needed to ensure sufficient current to all target devices.

E.6.2 Using a Target-System Clock

Figure E-6 shows an application with the system's test clock generated in the target system. In this application, the emulator's TCK signal is left unconnected.

Figure E-6. Target-System-Generated Test Clock

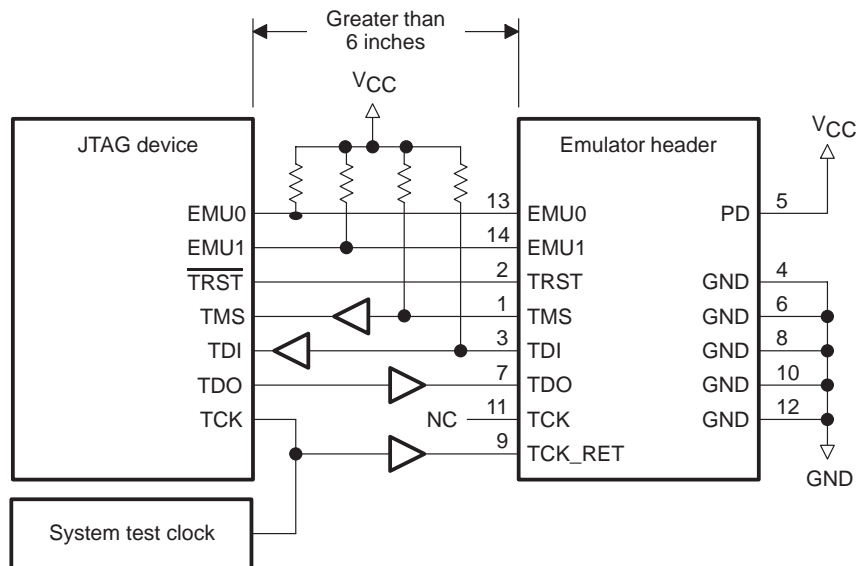

Note: When the TMS and TDI lines are buffered, pullup resistors must be used to hold the buffer inputs at a known level when the emulator cable is not connected.

There are two benefits in generating the test clock in the target system:

- The emulator provides only a single 10.368-MHz test clock. If you allow the target system to generate your test clock, you can set the frequency to match your system requirements.
- In some cases, you may have other devices in your system that require a test clock when the emulator is not connected. The system test clock also serves this purpose.

E.6.3 Configuring Multiple Processors

Figure E–7 shows a typical daisy-chained multiprocessor configuration that meets the minimum requirements of the IEEE 1149.1 specification. The emulation signals are buffered to isolate the processors from the emulator and provide adequate signal drive for the target system. One of the benefits of this interface is that you can slow down the test clock to eliminate timing problems. Follow these guidelines for multiprocessor support:

- ❑ The processor TMS, TDI, TDO, and TCK signals must be buffered through the same physical device package for better control of timing skew.
- ❑ The input buffers for TMS, TDI, and TCK should have pullup resistors connected to V_{CC} to hold these signals at a known value when the emulator is not connected. A resistor value of 4.7 k Ω or greater is suggested.
- ❑ Buffering EMU0 and EMU1 is optional but highly recommended to provide isolation. These are not critical signals and do not have to be buffered through the same physical package as TMS, TCK, TDI, and TDO.

Figure E–7. Multiprocessor Connections

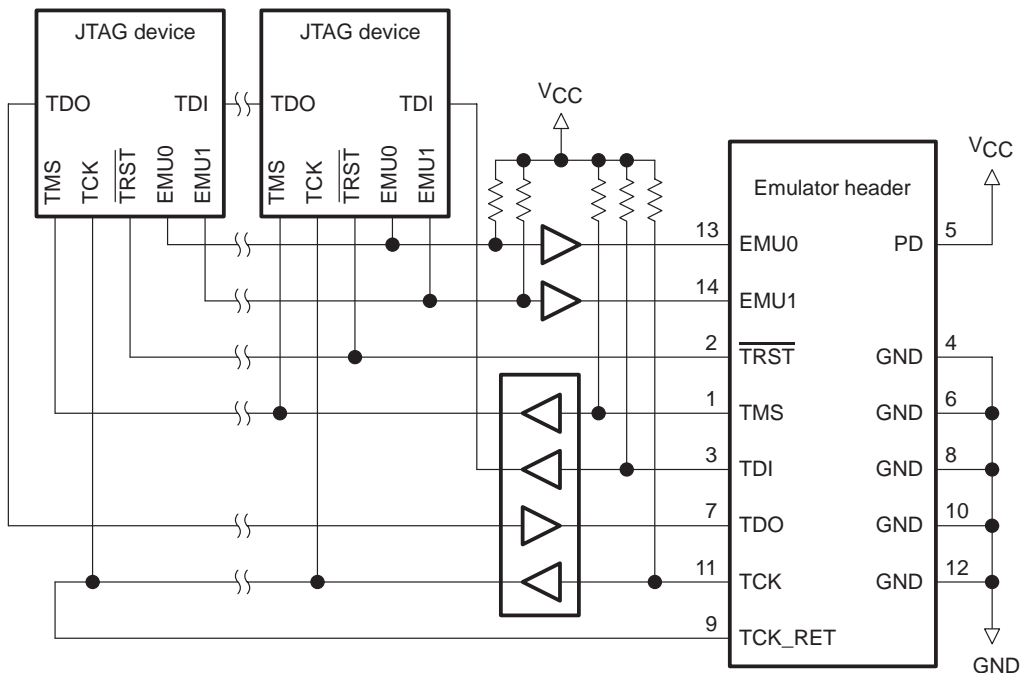

E.7 Physical Dimensions for the 14-Pin Emulator Connector

The JTAG emulator target cable consists of a 3-foot section of jacketed cable that connects to the emulator, an active cable pod, and a short section of jacketed cable that connects to the target system. The overall cable length is approximately 3 feet 10 inches. Figure E-8 and Figure E-9 (page E-15) show the physical dimensions for the target cable pod and short cable. The cable pod box is nonconductive plastic with four recessed metal screws.

Figure E-8. Pod/Connector Dimensions

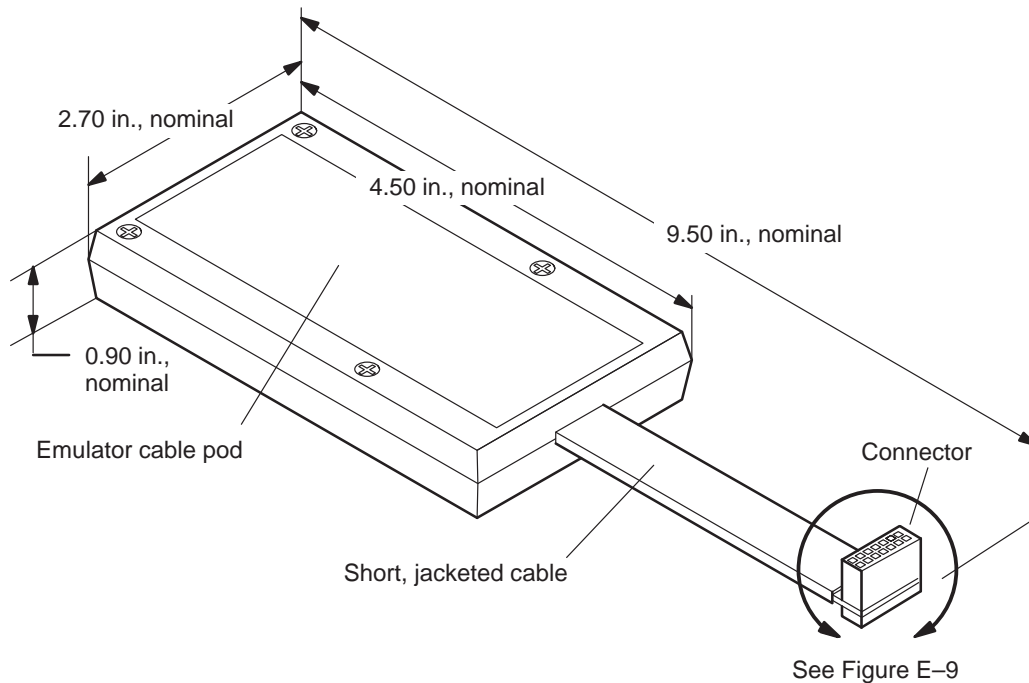

Note: All dimensions are in inches and are nominal dimensions, unless otherwise specified. Pin-to-pin spacing on the connector is 0.100 inches in both the X and Y planes.

Figure E-9. 14-Pin Connector Dimensions

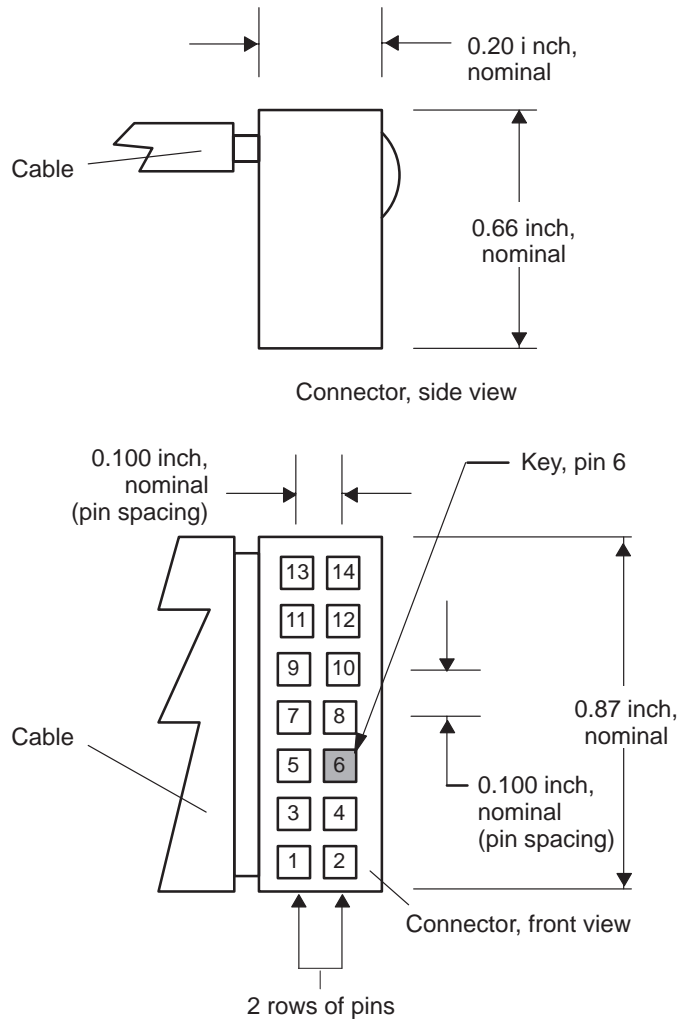

E.8 Emulation Design Considerations

This section describes the use and application of the scan path linker (SPL), which can simultaneously add all four secondary JTAG scan paths to the main scan path. It also describes the use of the emulation pins and the configuration of multiple processors.

E.8.1 Using Scan Path Linkers

You can use the TI ACT8997 scan path linker (SPL) to divide the JTAG emulation scan path into smaller, logically connected groups of 4 to 16 devices. As described in the *Advanced Logic and Bus Interface Logic Data Book*, the SPL is compatible with the JTAG emulation scanning. The SPL is capable of adding any combination of its four secondary scan paths into the main scan path.

A system of multiple, secondary JTAG scan paths has better fault tolerance and isolation than a single scan path. Since an SPL has the capability of adding all secondary scan paths to the main scan path simultaneously, it can support global emulation operations, such as starting or stopping a selected group of processors.

TI emulators do not support the nesting of SPLs (for example, an SPL connected to the secondary scan path of another SPL). However, you can have multiple SPLs on the main scan path.

Scan path selectors are not supported by this emulation system. The TI ACT8999 scan path selector is similar to the SPL, but it can add only one of its secondary scan paths at a time to the main JTAG scan path. Thus, global emulation operations are not assured with the scan path selector.

You can insert an SPL on a backplane so that you can add up to four device boards to the system without the jumper wiring required with nonbackplane devices. You connect an SPL to the main JTAG scan path in the same way you connect any other device. Figure E–10 shows how to connect a secondary scan path to an SPL.

Figure E–10. Connecting a Secondary JTAG Scan Path to a Scan Path Linker

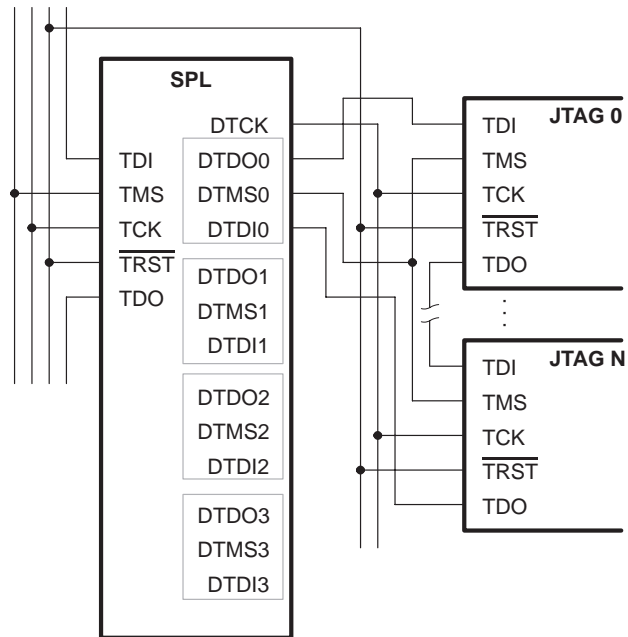

The $\overline{\text{TRST}}$ signal from the main scan path drives all devices, even those on the secondary scan paths of the SPL. The TCK signal on each target device on the secondary scan path of an SPL is driven by the SPL's DTCK signal. The TMS signal on each device on the secondary scan path is driven by the respective DTMS signals on the SPL.

DTDO0 on the SPL is connected to the TDI signal of the first device on the secondary scan path. DTDI0 on the SPL is connected to the TDO signal of the last device in the secondary scan path. Within each secondary scan path, the TDI signal of a device is connected to the TDO signal of the device before it. If the SPL is on a backplane, its secondary JTAG scan paths are on add-on boards; if signal degradation is a problem, you may need to buffer both the $\overline{\text{TRST}}$ and DTCK signals. Although degradation is less likely for DTMS $_n$ signals, you may also need to buffer them for the same reasons.

E.8.2 Emulation Timing Calculations for a Scan Path Linker (SPL)

Example E–3 and Example E–4 help you to calculate the key emulation timings in the SPL secondary scan path of your system. For actual target timing parameters, see the appropriate device data sheet for your target device.

The examples use the following assumptions:

$t_{su}(TTMS)$	Setup time, target TMS/TDI to TCK high	10 ns
$t_d(TTDO)$	Delay time, target TDO from TCK low	15 ns
$t_d(bufmax)$	Delay time, target buffer, maximum	10 ns
$t_d(bufmin)$	Delay time, target buffer, minimum	1 ns
$t_{(bufskew)}$	Skew time, target buffer, between two devices in the same package: $[t_d(bufmax) - t_d(bufmin)] \times 0.15$	1.35 ns
$t_{(TCKfactor)}$	Duty cycle, TCK assume a 40/60% clock	0.4 (40%)

Also, the examples use the following values from the SPL data sheet:

$t_d(DTMSmax)$	Delay time, SPL DTMS/DTDO from TCK low, maximum	31 ns
$t_{su}(DTDLmin)$	Setup time, DTDI to SPL TCK high, minimum	7 ns
$t_d(DTCKHmin)$	Delay time, SPL DTCK from TCK high, minimum	2 ns
$t_d(DTCKLmax)$	Delay time, SPL DTCK from TCK low, maximum	16 ns

There are two key timing paths to consider in the emulation design:

- The TCK-to-DTMS/DTDO path, called $t_{pd}(TCK-DTMS)$
- The TCK-to-DTDI path, called $t_{pd}(TCK-DTDI)$

Of the following two cases, the worst-case path delay is calculated to determine the maximum system test clock frequency.

Example E–3. Key Timing for a Single-Processor System Without Buffering (SPL)

$$\begin{aligned}
 t_{pd(TCK-DTMS)} &= \frac{[t_d(DTMS_{max}) + t_d(DTCKH_{min}) + t_{su}(TTMS)]}{t_{TCKfactor}} \\
 &= \frac{(31 \text{ ns} + 2 \text{ ns} + 10 \text{ ns})}{0.4} \\
 &= 107.5 \text{ ns, or } 9.3 \text{ MHz} \\
 t_{pd(TCK-DTDI)} &= \frac{[t_d(TTDO) + t_d(DTCKL_{max}) + t_{su}(DTD L_{min})]}{t_{TCKfactor}} \\
 &= \frac{(15 \text{ ns} + 16 \text{ ns} + 7 \text{ ns})}{0.4} \\
 &= 9.5 \text{ ns, or } 10.5 \text{ MHz}
 \end{aligned}$$

In this case, the TCK-to-DTMS/DTD L path is the limiting factor.

Example E–4. Key Timing for a Single- or Multiprocessor-System With Buffered Input and Output (SPL)

$$\begin{aligned}
 t_{pd(TCK-TDMS)} &= \frac{[t_d(DTMS_{max}) + t_{(DTCKH_{min})} + t_{su}(TTMS) + t_{(bufskew)}]}{t_{TCKfactor}} \\
 &= \frac{(31 \text{ ns} + 2 \text{ ns} + 10 \text{ ns} + 1.35 \text{ ns})}{0.4} \\
 &= 110.9 \text{ ns, or } 9.0 \text{ MHz} \\
 t_{pd(TCK-DTDI)} &= \frac{[t_d(TTDO) + t_d(DTCKL_{max}) + t_{su}(DTD L_{min}) + t_{(bufskew)}]}{t_{TCKfactor}} \\
 &= \frac{(15 \text{ ns} + 15 \text{ ns} + 7 \text{ ns} + 10 \text{ ns})}{0.4} \\
 &= 120 \text{ ns, or } 8.3 \text{ MHz}
 \end{aligned}$$

In this case, the TCK-to-DTDI path is the limiting factor.

E.8.3 Using Emulation Pins

The EMU0/1 pins of TI devices are bidirectional, 3-state output pins. When in an inactive state, these pins are at high impedance. When the pins are active, they provide one of two types of output:

- ❑ **Signal Event.** The EMU0/1 pins can be configured via software to signal internal events. In this mode, driving one of these pins low can cause devices to signal such events. To enable this operation, the EMU0/1 pins function as open-collector sources. External devices such as logic analyzers can also be connected to the EMU0/1 signals in this manner. If such an external source is used, it must also be connected via an open-collector source.
- ❑ **External Count.** The EMU0/1 pins can be configured via software as totem-pole outputs for driving an external counter. If the output of more than one device is configured for totem-pole operation, then these devices can be damaged. The emulation software detects and prevents this condition. However, the emulation software has no control over external sources on the EMU0/1 signal. Therefore, all external sources must be inactive when any device is in the external count mode.

TI devices can be configured by software to halt processing if their EMU0/1 pins are driven low. This feature combined with the signal event output, allows one TI device to halt all other TI devices on a given event for system-level debugging.

If you route the EMU0/1 signals between multiple boards, they require special handling because they are more complex than normal emulation signals. Figure E–11 shows an example configuration that allows any processor in the system to stop any other processor in the system. Do not tie the EMU0/1 pins of more than 16 processors together in a single group without using buffers. Buffers provide the crisp signals that are required during a RUNB (run benchmark) debugger command or when the external analysis counter feature is used.

Figure E–11. EMU0/1 Configuration to Meet Timing Requirements of Less Than 25 ns

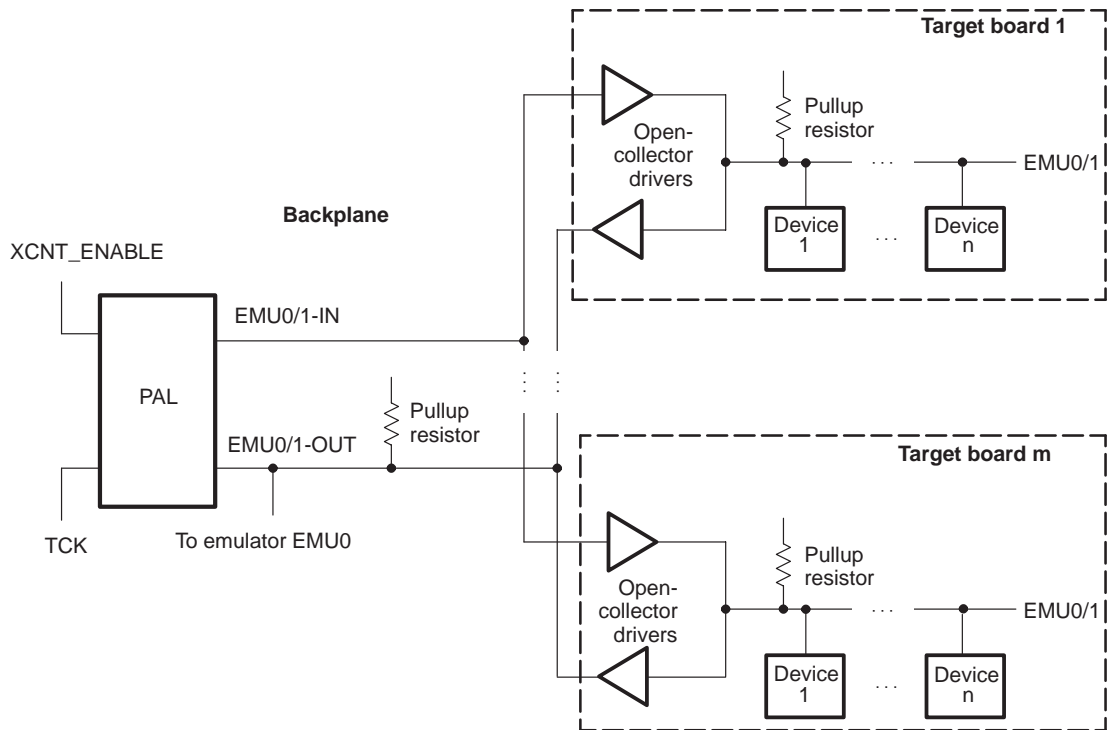

- Notes:**
- 1) The low time on EMU0/1-IN should be at least one TCK cycle and less than 10 μ s. Software sets the EMU0/1-OUT pin to a high state.
 - 2) To enable the open-collector driver and pullup resistor on EMU1 to provide rise/fall times of less than 25 ns, the modification shown in this figure is suggested. Rise times of more than 25 ns can cause the emulator to detect false edges during the RUNB command or when the external counter selected from the debugger analysis menu is used.

These seven important points apply to the circuitry shown in Figure E–11 and the timing shown in Figure E–12:

- Open-collector drivers isolate each board. The EMU0/1 pins are tied together on each board.
- At the board edge, the EMU0/1 signals are split to provide both input and output connections. This is required to prevent the open-collector drivers from acting as latches that can be set only once.
- The EMU0/1 signals are bused down the backplane. Pullup resistors must be installed as required.

- ❑ The bused EMU0/1 signals go into a programmable logic array device PAL[®] whose function is to generate a low pulse on the EMU0/1-IN signal when a low level is detected on the EMU0/1-OUT signal. This pulse must be longer than one TCK period to affect the devices but less than 10 μ s to avoid possible conflicts or retriggering once the emulation software clears the device's pins.
- ❑ During a RUNB debugger command or other external analysis count, the EMU0/1 pins on the target device become totem-pole outputs. The EMU1 pin is a ripple carry-out of the internal counter. EMU0 becomes a *processor-halted* signal. During a RUNB or other external analysis count, the EMU0/1-IN signal to all boards must remain in the high (disabled) state. You must provide some type of external input (XCNT_ENABLE) to the PAL[®] to disable the PAL[®] from driving EMU0/1-IN to a low state.
- ❑ If you use sources other than TI processors (such as logic analyzers) to drive EMU0/1, their signal lines must be isolated by open-collector drivers and be inactive during RUNB and other external analysis counts.
- ❑ You must connect the EMU0/1-OUT signals to the emulation header or directly to a test bus controller.

Figure E–12. Suggested Timings for the EMU0 and EMU1 Signals

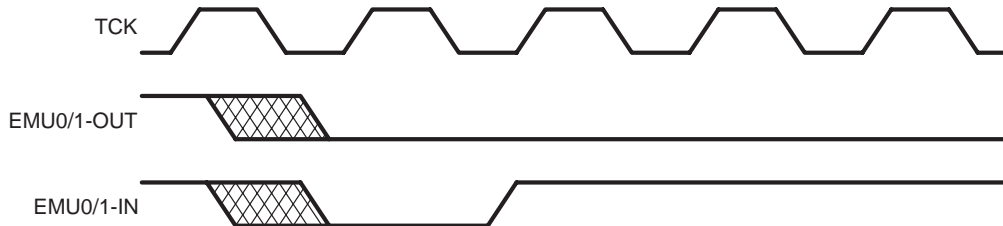
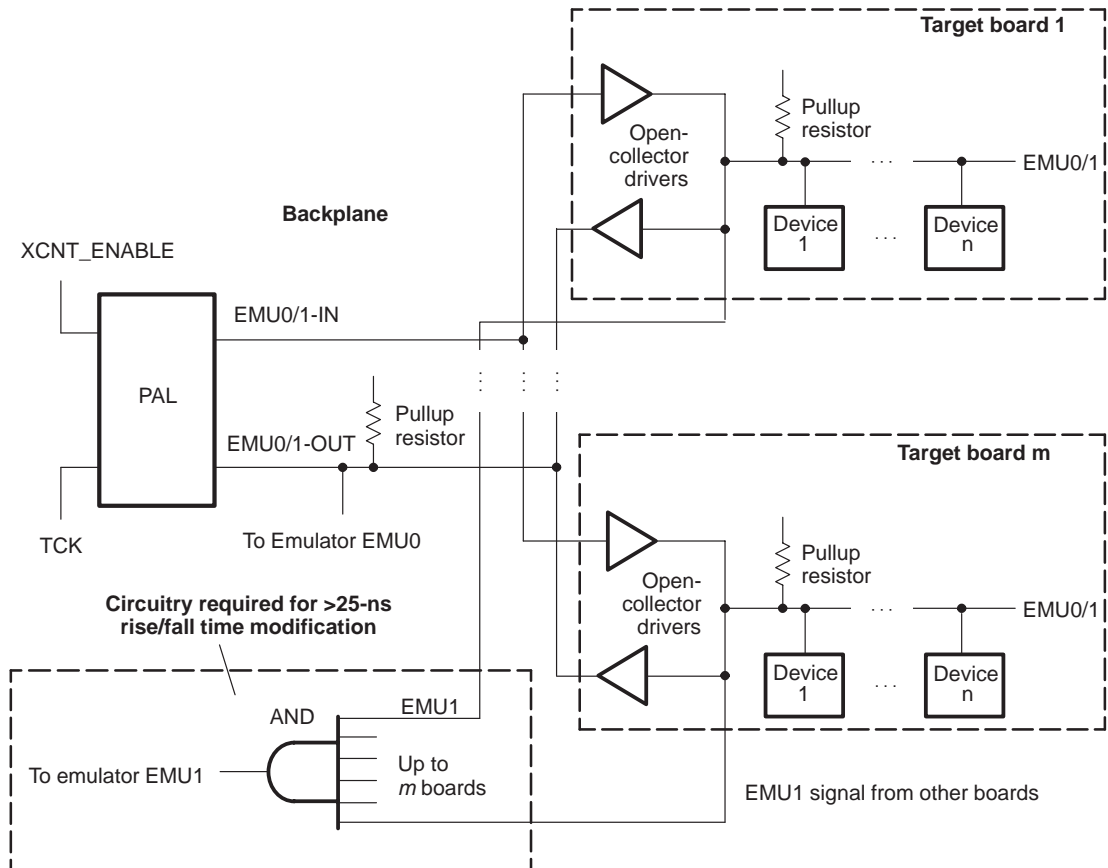

Figure E–13. EMU0/1 Configuration With Additional AND Gate to Meet Timing Requirements of Greater Than 25 ns



- Notes:**
- 1) The low time on EMU0/1-IN should be at least one TCK cycle and less than 10 μ s. Software will set the EMU0/1-OUT port to a high state.
 - 2) To enable the open-collector driver and pullup resistor on EMU1 to provide rise/fall time of greater than 25 ns, the modification shown in this figure is suggested. Rise times of more than 25 ns can cause the emulator to detect false edges during the RUNB command or when the external counter selected from the debugger analysis menu is used.

You do not need to have devices on one target board stop devices on another target board using the EMU0/1 signals (see the circuit in Figure E–14). In this configuration, the global-stop capability is lost. It is important not to overload EMU0/1 with more than 16 devices.

Figure E–14. EMU0/1 Configuration Without Global Stop

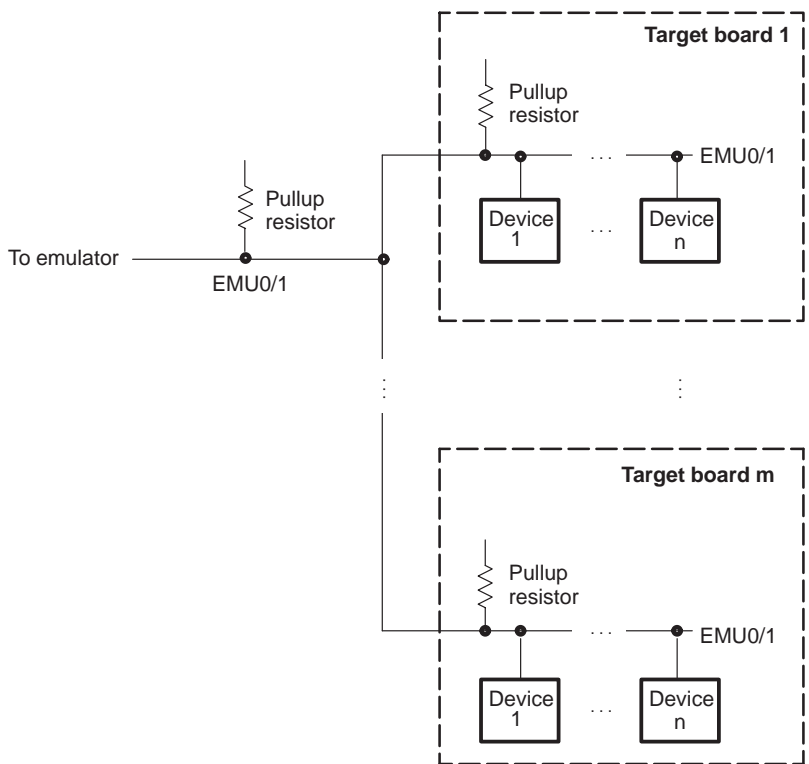

Note: The open-collector driver and pullup resistor on EMU1 must be able to provide rise/fall times of less than 25 ns. Rise times of more than 25 ns can cause the emulator to detect false edges during the RUNB command or when the external counter selected from the debugger analysis menu is used. If this condition cannot be met, then the EMU0/1 signals from the individual boards must be ANDed together (as shown in Figure E–14) to produce an EMU0/1 signal for the emulator.

E.8.4 Performing Diagnostic Applications

For systems that require built-in diagnostics, it is possible to connect the emulation scan path directly to a TI ACT8990 test bus controller (TBC) instead of the emulation header. The TBC is described in the Texas Instruments *Advanced Logic and Bus Interface Logic Data Book*. Figure E–15 shows the scan path connections of *n* devices to the TBC.

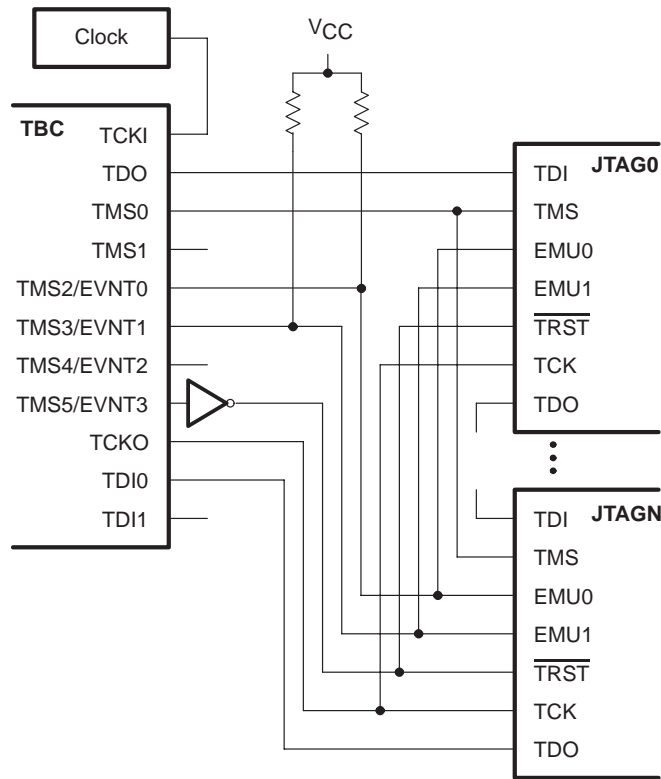
Figure E–15. TBC Emulation Connections for n JTAG Scan Paths

In the system design shown in Figure E–15, the TBC emulation signals TCKI, TDO, TMS0, TMS2/EVNT0, TMS3/EVNT1, TMS5/EVNT3, TCKO, and TDI0 are used, and TMS1, TMS4/EVNT2, and TDI1 are not connected. The target devices' EMU0 and EMU1 signals are connected to V_{CC} through pullup resistors and tied to the TBC's TMS2/EVNT0 and TMS3/EVNT1 pins, respectively. The TBC's TCKI pin is connected to a clock generator. The TCK signal for the main JTAG scan path is driven by the TBC's TCKO pin.

On the TBC, the TMS0 pin drives the TMS pins on each device on the main JTAG scan path. TDO on the TBC connects to TDI on the first device on the main JTAG scan path. TDI0 on the TBC is connected to the TDO signal of the last device on the main JTAG scan path. Within the main JTAG scan path, the TDI signal of a device is connected to the TDO signal of the device before it. $\overline{\text{TRST}}$ for the devices can be generated either by inverting the TBC's TMS5/EVNT3 signal for software control or by logic on the board itself.

Glossary

A

A0–A15: Collectively, the external address bus; the 16 pins are used in parallel to address external data memory, program memory, or I/O space.

ACC: See *accumulator*.

ACCH: *Accumulator high word*. The upper 16 bits of the accumulator. See also *accumulator*.

ACCL: *Accumulator low word*. The lower 16 bits of the accumulator. See also *accumulator*.

accumulator: A 32-bit register that stores the results of operations in the central arithmetic logic unit (CALU) and provides an input for subsequent CALU operations. The accumulator also performs shift and rotate operations.

ADC bit: A *detect complete bit*. Bit 14 of the I/O status register (IOSR); a flag bit used in the implementation of automatic baud-rate detection in the asynchronous serial port.

address: The location of program code or data stored in memory.

addressing mode: A method by which an instruction interprets its operands to acquire the data it needs. See also *direct addressing*; *immediate addressing*; *indirect addressing*.

address visibility bit (AVIS): A bit in the 'C209's wait-state generator control register (WSGR) that allows the internal program address to appear at the 'C209 address pins. This allows the internal program address to be traced.

ADTR: *Asynchronous data transmit and receive register*. A 16-bit register used by the on-chip asynchronous serial port. Data to transmit is written to the 8 LSBs of the ADTR, and received data is read from the 8 LSBs of the ADTR. See also *ARSR*.

analog-to-digital (A/D) converter: A circuit that translates an analog signal to a digital signal.

AR: See *auxiliary register*.

AR0–AR7: *Auxiliary registers 0 through 7. See auxiliary register.*

ARAU: See *auxiliary register arithmetic unit (ARAU)*.

ARB: See *auxiliary register pointer buffer (ARB)*.

ARP: See *auxiliary register pointer (ARP)*.

ARSR: *Asynchronous serial port receive shift register.* A 16-bit register in the on-chip asynchronous serial port that receives data from the RX pin one bit at a time. When full, ARSR transfers its data to the ADTR. See also *ADTR*.

ASPCR: *Asynchronous serial port control register.* A 16-bit register used to control the on-chip asynchronous serial port; contains bits for setting port modes, enabling or disabling the automatic baud-rate detection logic, selecting the number of stop bits, enabling or disabling interrupts, setting the default level on the TX pin, configuring pins IO3–IO0, and resetting the port.

auxiliary register: One of eight 16-bit registers (AR7–AR0) used as pointers to addresses in data space. The registers are operated on by the auxiliary register arithmetic unit (ARAU) and are selected by the auxiliary register pointer (ARP).

auxiliary register arithmetic unit (ARAU): A 16-bit arithmetic unit used to increment, decrement, or compare the contents of the auxiliary registers. Its primary function is manipulating auxiliary register values for indirect addressing.

auxiliary register pointer (ARP): A 3-bit field in status register ST0 that points to the current auxiliary register.

auxiliary register pointer buffer (ARB): A 3-bit field in status register ST1 that holds the previous value of the auxiliary register pointer (ARP).

AVIS: See *address visibility bit (AVIS)*.

AXSR: *Asynchronous serial port transmit shift register.* A 16-bit register in the asynchronous serial port that receives data from the ADTR and transfers it one bit at a time to the TX pin. See also *ADTR*; *TX pin*.

B

- B0:** An on-chip block of dual-access RAM that can be configured as either data memory or program memory, depending on the value of the CNF bit in status register ST1.
- B1:** An on-chip block of dual-access RAM available for data memory.
- B2:** An on-chip block of dual-access RAM available for data memory.
- baud-rate divisor register (BRD):** A register for the asynchronous serial port that is used to set the serial port's baud rate.
- BI bit:** *Break interrupt bit.* Bit 13 of the I/O status register (IOSR); indicates when a break is detected on the asynchronous receive (RX) pin.
- $\overline{\text{BIO}}$ pin:** A general-purpose input pin that can be tested by conditional instructions that cause a branch when an external device drives $\overline{\text{BIO}}$ low.
- bit-reversed indexed addressing:** A method of indirect addressing that allows efficient I/O operations by resequencing the data points in a radix-2 FFT program. The direction of carry propagation in the ARAU is reversed.
- boot loader:** A built-in segment of code that transfers code from an 8-bit external source to a 16-bit external program destination at reset.
- $\overline{\text{BOOT}}$ pin:** The pin that enables the on-chip boot loader. When $\overline{\text{BOOT}}$ is held low, the processor executes the boot loader program after a hardware reset. When $\overline{\text{BOOT}}$ is held high, the processor skips execution of the boot loader and accesses off-chip program-memory at reset.
- $\overline{\text{BR}}$:** *Bus request pin.* This pin is tied to the $\overline{\text{BR}}$ signal, which is asserted when a global data memory access is initiated.
- branch:** A switching of program control to a nonsequential program-memory address.
- BRD:** See *baud-rate divisor register (BRD)*.
- burst mode:** A synchronous serial port mode in which the transmission or reception of each word is preceded by a frame synchronization pulse. See also *continuous mode*.

C

- C bit:** See *carry bit (C)*.
- CAD bit:** *Calibrate A detect bit.* Bit 5 of the ASPCR; enables and disables the automatic baud-rate detection logic of the on-chip asynchronous serial port.

CALU: See *central arithmetic logic unit (CALU)*.

carry bit: Bit 9 of status register ST1; used by the CALU for extended arithmetic operations and accumulator shifts and rotates. The carry bit can be tested by conditional instructions.

central arithmetic logic unit (CALU): The 32-bit wide main arithmetic logic unit for the 'C2xx CPU that performs arithmetic and logic operations. It accepts 32-bit values for operations, and its 32-bit output is held in the accumulator.

CIO0–CIO3 bits: Bits 0–3 of the asynchronous serial port control register (ASPCR); they individually configure pins IO0–IO3 as either inputs or outputs. For example, CIO0 configures the IO0 pin. See also *DIO0–DIO3 bits*; *IO0–IO3 bits*.

CLK register: *CLKOUT1-pin control register*. Bit 0 of determines whether the CLKOUT1 signal is available at the CLKOUT1 pin.

CLKIN: *Input clock signal*. A clock source signal supplied to the on-chip clock generator at the CLKIN/X2 pin or generated internally by the on-chip oscillator. The clock generator divides or multiplies CLKIN to produce the CPU clock signal, CLKOUT1.

CLKMOD pin: (On the 'C209 only) Determines whether the on-chip clock generator is running in the divide-by-two or multiply-by-two mode. See also *clock mode*.

CLKOUT1: *Master clock output signal*. The output signal of the on-chip clock generator. The CLKOUT1 high pulse signifies the CPU's logic phase (when internal values are changed), and the CLKOUT1 low pulse signifies the CPU's latch phase (when the values are held constant).

CLKOUT1 cycle: See *CPU cycle*.

CLKOUT1-pin control register: See *CLK register*.

CLKR: *Receive clock input pin*. A pin that receives an external clock signal to clock data from the DR pin into the synchronous serial port receive shift register (RSR).

CLKX: *Transmit clock input/output pin*. A pin used to clock data from the synchronous serial port transmit shift register to the DX pin. If the serial port is configured to accept an external clock, this pin receives the clock signal. If the port is configured to generate an internal clock, this pin transmits the clock signal.

clock mode (clock generator): One of the modes which sets the internal CPU clock frequency to a fraction or multiple of the frequency of the input clock signal CLKIN. The 'C209 has two clock modes ($\div 2$ and $\times 2$); other 'C2xx devices have four clock modes ($\div 2$, $\times 1$, $\times 2$, and $\times 4$).

clock mode (synchronous serial port): See *clock mode bit (MCM)*.

clock mode bit (MCM): Bit 2 of the synchronous serial port control register (SSPCR); determines whether the source signal for clocking synchronous serial port transfers is external or internal.

CNF bit: *DARAM configuration bit.* Bit 12 in status register ST1. CNF is used to determine whether the on-chip RAM block B0 is mapped to program space or data space.

codec: A device that codes in one direction of transmission and decodes in another direction of transmission.

COFF: *Common object file format.* An output format that promotes modular programming by supporting sections; the format of files created by the TMS320C1x/C2x/C2xx/C5x assembler and linker.

context saving/restoring: Saving the system status when the device enters a subroutine (such as an interrupt service routine) and restoring the system status when exiting the subroutine. On the 'C2xx, only the program counter value is saved and restored automatically; other context saving and restoring must be performed by the subroutine.

continuous mode: A synchronous serial port mode in which only one frame synchronization pulse is necessary to transmit or receive several consecutive packets at maximum frequency. See also *burst mode*.

CPU: *Central processing unit.* The 'C2xx CPU is the portion of the processor involved in arithmetic, shifting, and Boolean logic operations, as well as the generation of data- and program-memory addresses. The CPU includes the central arithmetic logic unit (CALU), the multiplier, and the auxiliary register arithmetic unit (ARAU).

CPU cycle: The time required for the CPU to go through one logic phase (during which internal values are changed) and one latch phase (during which the values are held constant).

current AR: See *current auxiliary register*.

current auxiliary register: The auxiliary register pointed to by the auxiliary register pointer (ARP). The auxiliary registers are AR0 (ARP = 0) through AR7 (ARP = 7). See also *auxiliary register, next auxiliary register*.

current data page: The data page indicated by the content of the data page pointer (DP). See also *data page*; *DP*.

D

D0–D15: Collectively, the external data bus; the 16 pins are used in parallel to transfer data between the 'C2xx and external data memory, program memory, or I/O space.

DARAM: *Dual-access RAM*. RAM that can be accessed twice in a single CPU clock cycle. For example, your code can read from and write to DARAM in the same clock cycle.

DARAM configuration bit (CNF): See *CNF bit*.

data-address generation logic: Logic circuitry that generates the addresses for data memory reads and writes. This circuitry, which includes the auxiliary registers and the ARAU, can generate one address per machine cycle. See also *program-address generation logic*.

data page: One block of 128 words in data memory. Data memory contains 512 data pages. Data page 0 is the first page of data memory (addresses 0000h–007Fh); data page 511 is the last page (addresses FF80h–FFFFh). See also *data page pointer (DP)*; *direct addressing*.

data page 0: Addresses 0000h–007Fh in data memory; contains the memory-mapped registers, a reserved test/emulation area for special information transfers, and the scratch-pad RAM block (B2).

data page pointer (DP): A 9-bit field in status register ST0 that specifies which of the 512 data pages is currently selected for direct address generation. When an instruction uses direct addressing to access a data-memory value, the DP provides the nine MSBs of the data-memory address, and the instruction provides the seven LSBs.

data-read address bus (DRAB): A 16-bit internal bus that carries the address for each read from data memory.

data read bus (DRDB): A 16-bit internal bus that carries data from data memory to the CALU and the ARAU.

data-write address bus (DWAB): A 16-bit internal bus that carries the address for each write to data memory.

data write bus (DWEB): A 16-bit internal bus that carries data to both program memory and data memory.

- decode phase:** The phase of the pipeline in which the instruction is decoded. See also *pipeline*; *instruction-fetch phase*; *operand-fetch phase*; *instruction-execute phase*.
- delta interrupt:** An asynchronous serial port interrupt (TXRXINT) that is generated if a change takes place on one of these general-purpose I/O pins: IO0, IO1, IO2, or IO3.
- digital loopback mode:** A synchronous serial port test mode in which the receive pins are connected internally to the transmit pins on the same device. This mode, enabled or disabled by the DLB bit, allows you to test whether the port is operating correctly.
- DIM:** *Delta interrupt mask bit.* Bit 9 of the asynchronous serial port control register (ASPCR); enables or disables delta interrupts.
- DIO0–DIO3 bits:** Bits 4–7 of the IOSR. If the asynchronous serial port is enabled (the URST bit of the ASPCR is 1), these bits are used to track a change from a previous known or unknown signal value at the corresponding I/O pin (IO0–IO3). For example, DIO0 indicates a change on the IO0 pin. See also *CIO0–CIO3 bits*; *IO0–IO3 bits*.
- direct addressing:** One of the methods used by an instruction to address data-memory. In direct addressing, the data-page pointer (DP) holds the nine MSBs of the address (the current data page), and the instruction word provides the seven LSBs of the address (the offset). See also *indirect addressing*.
- DIV2/DIV1:** Two pins used together to determine the clock mode of the 'C2xx clock generator ($\div 2$, $\times 1$, $\times 2$, or $\times 4$). (The 'C209 uses the CLKMOD pin and has only two clock modes, $\div 2$ and $\times 2$.)
- divide-down value:** The value in the timer divide-down register (TDDR). This value is the prescale count for the on-chip timer. The larger the divide-down value, the slower the timer interrupt rate.
- DLB bit:** Bit 0 of the synchronous serial port control register (SSPCR); enables or disables digital loopback mode for the on-chip synchronous serial port. See also *digital loopback mode*.
- DP:** See *data page pointer (DP)*.
- DR bit:** *Data ready indicator for the receiver.* Bit 8 of the I/O status register (IOSR); indicates whether a new 8-bit character has been received in the ADTR of the asynchronous serial port.
- DR pin:** *Serial data receive pin.* A synchronous serial port pin that receives serial data. As each bit is received at DR, the bit is transferred serially into the receive shift register (RSR).

DRAB: See *data-read address bus (DRAB)*.

DRDB: See *data read bus (DRDB)*.

\overline{DS} : *Data memory select pin.* The 'C2xx asserts \overline{DS} to indicate an access to external data memory (local or global).

DSWS: *Data-space wait-state bit(s).* A value in the wait-state generator control register (WSGR) that determines the number of wait states applied to reads from and writes to off-chip data space. On the 'C209, DSWS is bit 1 of the WSGR; on other 'C2xx devices, DSWS is bits 8–6.

dual-access RAM: See *DARAM*.

dummy cycle: A CPU cycle in which the CPU intentionally reloads the program counter with the same address.

DWAB: See *data-write address bus (DWAB)*.

DWEB: See *data write bus (DWEB)*.

DX pin: *Serial data transmit pin.* The pin on which data is transmitted serially from the synchronous serial port; accepts a data word one bit at a time from the transmit shift register (XSR).

E

execute phase: The fourth phase of the pipeline; the phase in which the instruction is executed. See also *pipeline; instruction-fetch phase; instruction-decode phase; operand-fetch phase*.

external interrupt: A hardware interrupt triggered by an external event sending an input through an interrupt pin.

F

FE bit: *Framing error indicator bit.* Bit 10 of I/O status register (IOSR); indicates whether a valid stop bit has been detected during the reception of a character into the asynchronous serial port.

FIFO buffer: *First-in, first-out buffer.* A portion of memory in which data is stored and then retrieved in the same order in which it was stored. The synchronous serial port has two four-word-deep FIFO buffers: one for its transmit operation and one for its receive operation.

flash memory: Electronically erasable and programmable, nonvolatile (read-only) memory.

- FR0/FR1:** *FIFO receive-interrupt bits.* Bits 8 and 9 of the synchronous serial port control register (SSPCR); together they set an interrupt trigger condition based on the number of words in the receive FIFO buffer.
- frame synchronization (frame sync) mode:** One of two modes in the synchronous serial port that determine whether frame synchronization pulses are necessary between consecutive data transfers. See also *burst mode*; *continuous mode*.
- frame synchronization (frame sync) pulse:** A pulse that signals the start of a transmission from or reception into the synchronous serial port.
- framing error:** An error that occurs when a data character received by the asynchronous serial port does not have a valid stop bit. See also *FE bit*.
- FREE bit (asynchronous serial port):** Bit 15 of the asynchronous serial port control register (ASPCR); determines whether the port is in free-run mode or an emulation mode. When FREE = 0, bit 14 (SOFT) determines which emulation mode is selected.
- FREE bit (synchronous serial port):** Bit 15 of the synchronous serial port control register (SSPCR); determines whether the port is in free-run mode or an emulation mode. When FREE = 0, bit 14 (SOFT) determines which emulation mode is selected.
- FREE bit (timer):** Bit 11 of the timer control register (TCR); determines whether the timer is in free-run mode or an emulation mode. When FREE = 0, bit 14 (SOFT) determines which emulation mode is selected. FREE and SOFT are not available in the TCR of the 'C209.
- FSM bit:** Bit 1 of the synchronous serial port control register (SSPCR); determines the frame synchronization mode for the synchronous serial port. See also *burst mode*; *continuous mode*.
- FSR pin:** *Receive frame synchronization pin.* This input pin accepts a frame sync pulse that initiates the reception process of the synchronous serial port.
- FSX pin:** *Transmit frame synchronization pin.* This input/output pin accepts/generates a frame sync pulse that initiates the transmission process of the synchronous serial port. If the port is configured for accepting an external frame sync pulse, the FSX pin receives the pulse. If the port is configured for generating an internal frame sync pulse, the FSX pin transmits the pulse.
- FT0/FT1:** *FIFO transmit-interrupt bits.* Bits 10 and 11 of the synchronous serial port control register (SSPCR); together they set an interrupt trigger condition based on the number of words in the transmit FIFO buffer.

G

general-purpose input/output pins: Pins that can be used to accept input signals and/or send output signals but are not linked to specific uses. These pins are the input pin $\overline{\text{BIO}}$, the output pin XF, and the input/output pins IO0, IO1, IO2, and IO3. (IO0–IO3 are not available on the 'C209.)

global data space: One of the four 'C2xx address spaces. The global data space can be used to share data with other processors within a system and can serve as additional data space. See also *local data space*.

GREG: *Global memory allocation register.* A memory-mapped register used for specifying the size of the global data memory. Addresses not allocated by the GREG for global data memory are available for local data memory.

H

hardware interrupt: An interrupt triggered through physical connections with on-chip peripherals or external devices.

$\overline{\text{HOLD}}$: An input signal that allows external devices to request control of the external buses. If an external device drives the $\overline{\text{HOLD/INT1}}$ pin low and the CPU sends an acknowledgement at the $\overline{\text{HOLDA}}$ pin, the external device has control of the buses until it drives $\overline{\text{HOLD}}$ high or a nonmaskable hardware interrupt is generated. If $\overline{\text{HOLD}}$ is not used, it should be pulled high.

$\overline{\text{HOLDA}}$: *$\overline{\text{HOLD}}$ acknowledge signal.* An output signal sent to the $\overline{\text{HOLDA}}$ pin by the CPU in acknowledgement of a properly initiated HOLD operation. When $\overline{\text{HOLDA}}$ is low, the processor is in a holding state and the address, data, and memory-control lines are available to external circuitry.

HOLD operation: An operation on the 'C2xx that allows for direct memory access of external memory and I/O devices. A HOLD operation is initiated by a $\overline{\text{HOLD/INT1}}$ interrupt. When the corresponding interrupt service routine executes an IDLE instruction, the external buses enter the high-impedance state and the $\overline{\text{HOLDA}}$ signal is asserted. The buses return to their normal state, and the HOLD operation is concluded, when the processor exits the IDLE state.

I

$\overline{\text{IACK}}$: See *interrupt acknowledge signal ($\overline{\text{IACK}}$)*.

- IC:** (Used in earlier documentation.) See *interrupt control register (ICR)*.
- ICR:** See *interrupt control register (ICR)*.
- IFR:** See *interrupt flag register (IFR)*.
- immediate addressing:** One of the methods for obtaining data values used by an instruction; the data value is a constant embedded directly into the instruction word; data memory is not accessed.
- immediate operand/immediate value:** A constant given as an operand in an instruction that is using immediate addressing.
- IMR:** See *interrupt mask register (IMR)*.
- INO:** Bit 6 of the synchronous serial port control register (SSPCR); allows you to use the CLKR pin as a bit input. INO indicates the current logic level on CLKR.
- indirect addressing:** One of the methods for obtaining data values used by an instruction. When an instruction uses indirect addressing, data memory is addressed by the current auxiliary register. See also *direct addressing*.
- input clock signal:** See *CLKIN*.
- input/output status register:** See *I/O status register (IOSR)*.
- input shifter:** A 16- to 32-bit left barrel shifter that shifts incoming 16-bit data from 0 to 16 positions left relative to the 32-bit output.
- instruction-decode phase:** The second phase of the pipeline; the phase in which the instruction is decoded. See also *pipeline; instruction-fetch phase; operand-fetch phase; instruction-execute phase*.
- instruction-execute phase:** The fourth phase of the pipeline; the phase in which the instruction is executed. See also *pipeline; instruction-fetch phase; instruction-decode phase; operand-fetch phase*.
- instruction-fetch phase:** The first phase of the pipeline; the phase in which the instruction is fetched from program-memory. See also *pipeline; instruction-decode phase; operand-fetch phase; instruction-execute phase*.
- instruction register (IR):** A 16-bit register that contains the instruction being executed.
- instruction word:** A 16-bit value representing all or half of an instruction. An instruction that is fully represented by 16 bits uses one instruction word. An instruction that must be represented by 32 bits uses two instruction words (the second word is a constant).

$\overline{\text{INT1}}\text{--}\overline{\text{INT3}}$: Three external pins used to generate general-purpose hardware interrupts.

internal interrupt: A hardware interrupt caused by an on-chip peripheral.

interrupt: A signal sent to the CPU that (when not masked or disabled) forces the CPU into a subroutine called an interrupt service routine (ISR). This signal can be triggered by an external device, an on-chip peripheral, or an instruction (INTR, NMI, or TRAP).

interrupt acknowledge signal ($\overline{\text{IACK}}$): An output signal on the 'C209 that indicates that an interrupt has been received and that the program counter is fetching the interrupt vector that will force the processor into the appropriate interrupt service routine.

interrupt control register (ICR): A 16-bit register used to differentiate HOLD and $\overline{\text{INT1}}$ and to individually mask and flag $\overline{\text{INT2}}$ and $\overline{\text{INT3}}$.

interrupt flag register (IFR): A 16-bit memory-mapped register that indicates pending interrupts. Read the IFR to identify pending interrupts and write to the IFR to clear selected interrupts. Writing a 1 to any IFR flag bit clears that bit to 0.

interrupt latency: The delay between the time an interrupt request is made and the time it is serviced.

interrupt mask register (IMR): A 16-bit memory-mapped register used to mask external and internal interrupts. Writing a 1 to any IMR bit position enables the corresponding interrupt (when $\text{INTM} = 0$).

interrupt mode bit (INTM): Bit 9 in status register ST0; either enables all maskable interrupts that are not masked by the IMR or disables all maskable interrupts.

interrupt service routine (ISR): A module of code that is executed in response to a hardware or software interrupt.

interrupt trap: See *interrupt service routine (ISR)*.

interrupt vector: A branch instruction that leads the CPU to an interrupt service routine (ISR).

interrupt vector location: An address in program memory where an interrupt vector resides. When an interrupt is acknowledged, the CPU branches to the interrupt vector location and fetches the interrupt vector.

INTM bit: See *interrupt mode bit (INTM)*.

IO0–IO3 bits: Bits 0–3 of the IOSR. When pins IO0–IO3 are configured as inputs, these bits reflect the current logic levels on the pins. For example, the IO0 bit reflects the level on the IO0 pin. See also *CIO0–CIO3 bits*; *DIO0–DIO3 bits*.

IO0–IO3 pins: Four pins that can be individually configured as inputs or outputs. These pins can be used for interfacing the asynchronous serial port or as general-purpose I/O pins. See also *CIO0–CIO3 bits*; *DIO0–DIO3 bits*; *IO0–IO3 bits*.

I/O-mapped register: One of the on-chip registers mapped to addresses in I/O (input/output) space. These registers, which include the registers for the on-chip peripherals, must be accessed with the IN and OUT instructions. See also *memory-mapped register*.

I/O status register (IOSR): A register in the asynchronous serial port that provides status information about signals IO0–IO3 and about transfers in progress.

IOSR: See *I/O status register (IOSR)*.

IR: See *instruction register (IR)*.

\overline{IS} : *I/O space select pin*. The 'C2xx asserts \overline{IS} to indicate an access to external I/O space.

ISR: See *interrupt service routine (ISR)*.

ISWS: *I/O-space wait-state bit(s)*. A value in the wait-state generator control register (WSGR) that determines the number of wait states applied to reads from and writes to off-chip I/O space. On the 'C209, ISWS is bit 2 of the WSGR; on other 'C2xx devices, ISWS is bits 11–9.

L

latch phase: The phase of a CPU cycle during which internal values are held constant. See also *logic phase*; *CLKOUT1*.

local data space: The portion of data-memory addresses that are not allocated as global by the global memory allocation register (GREG). If none of the data-memory addresses are allocated for global use, all of data space is local. See also *global data space*.

logic phase: The phase of a CPU cycle during which internal values are changed. See also *latch phase*; *CLKOUT1*.

long-immediate value: A 16-bit constant given as an operand of an instruction that is using immediate addressing.

LSB: *Least significant bit.* The lowest order bit in a word. When used in plural form (LSBs), refers to a specified number of low-order bits, beginning with the lowest order bit and counting to the left. For example, the four LSBs of a 16-bit value are bits 0 through 3. See also *MSB*.

M

machine cycle: See *CPU cycle*.

maskable interrupt: A hardware interrupt that can be enabled or disabled through software. See also *nonmaskable interrupt*.

master clock output signal: See *CLKOUT1*.

master phase: See *logic phase*.

MCM bit: See *clock mode bit (MCM)*.

memory-mapped register: One of the on-chip registers mapped to addresses in data memory. See also *I/O-mapped register*.

microcomputer mode: A mode in which the on-chip ROM or flash memory is enabled. This mode is selected with the $\overline{MP/MC}$ pin. See also *MP/MC pin*; *microprocessor mode*.

microprocessor mode: A mode in which the on-chip ROM or flash memory is disabled. This mode is selected with the $\overline{MP/MC}$ pin. See also *MP/MC pin*; *microcomputer mode*.

micro stack (MSTACK): A register used for temporary storage of the program counter (PC) value when an instruction needs to use the PC to address a second operand.

MIPS: Million instructions per second.

MODE bit: Bit 4 of the interrupt control register (ICR); determines whether the $\overline{HOLD/INT1}$ pin is only negative-edge sensitive or both negative- and positive-edge sensitive.

MP/MC pin: A pin that indicates whether the processor is operating in microprocessor mode or microcomputer mode. $\overline{MP/MC}$ high selects microprocessor mode; $\overline{MP/MC}$ low selects microcomputer mode.

MSB: *Most significant bit.* The highest order bit in a word. When used in plural form (MSBs), refers to a specified number of high-order bits, beginning with the highest order bit and counting to the right. For example, the eight MSBs of a 16-bit value are bits 15 through 8. See also *LSB*.

N

MSTACK: See *micro stack*.

multiplier: A part of the CPU that performs 16-bit \times 16-bit multiplication and generates a 32-bit product. The multiplier operates using either signed or unsigned 2s-complement arithmetic.

next AR: See *next auxiliary register*.

next auxiliary register: The register that will be pointed to by the auxiliary register pointer (ARP) when an instruction that modifies ARP is finished executing. See also *auxiliary register*; *current auxiliary register*.

$\overline{\text{NMI}}$: A hardware interrupt that uses the same logic as the maskable interrupts but cannot be masked. It is often used as a soft reset. See also *maskable interrupt*; *nonmaskable interrupt*.

nonmaskable interrupt: An interrupt that can be neither masked by the interrupt mask register (IMR) nor disabled by the INTM bit of status register ST0.

NPAR: *Next program address register*. Part of the program-address generation logic. This register provides the address of the next instruction to the program counter (PC), the program address register (PAR), the micro stack (MSTACK), or the stack.

O

OE: *Receiver register overrun indicator bit*. Bit 9 of the I/O status register (IOSR); indicates whether overrun has occurred in the receiver of the asynchronous serial port (that is, whether an unread character in the ADTR has been overwritten by a new character).

operand: A value to be used or manipulated by an instruction; specified in the instruction.

operand-fetch phase: The third phase of the pipeline; the phase in which an operand or operands are fetched from memory. See also *pipeline*; *instruction-fetch phase*; *instruction-decode phase*; *instruction-execute phase*.

output shifter: 32- to 16-bit barrel left shifter. Shifts the 32-bit accumulator output from 0 to 7 bits left for quantization management, and outputs either the 16-bit high or low half of the shifted 32-bit data to the data write bus (DWEB).

OV bit: *Overflow flag bit.* Bit 12 of status register ST0; indicates whether the result of an arithmetic operation has exceeded the capacity of the accumulator.

overflow (in a register): A condition in which the result of an arithmetic operation exceeds the capacity of the register used to hold that result.

overflow (in the synchronous serial port): A condition in which the receive FIFO buffer of the port is full and another word is received in the RSR. (None of the contents of the FIFO buffer are overwritten by this new word.)

overflow mode: The mode in which an overflow in the accumulator will cause the accumulator to be loaded with a preset value. If the overflow is in the positive direction, the accumulator will be loaded with its most positive number. If the overflow is in the negative direction, the accumulator will be filled with its most negative number.

overrun: A condition in the receiver of the asynchronous serial port. Overrun occurs when an unread character in the ADTR is overwritten by a new character.

OVF bit: *Overflow bit (synchronous serial port).* Bit 7 of the synchronous serial port control register (SSPCR); indicates when the receive FIFO buffer of the port is full and another word is received in the RSR. (None of the contents of the FIFO buffer are overwritten by this new word.)

OVM bit: *Overflow mode bit.* Bit 11 of status register ST0; enables or disables overflow mode. See also *overflow mode*.

P

PAB: See *program address bus (PAB)*.

PAR: *Program address register.* A register that holds the address currently being driven on the program address bus for as many cycles as it takes to complete all memory operations scheduled for the current machine cycle.

PC: See *program counter (PC)*.

PCB: *Printed circuit board.*

pending interrupt: A maskable interrupt that has been successfully requested but is awaiting acknowledgement by the CPU.

period register: See *PRD*.

pipeline: A method of executing instructions in an assembly line fashion. The 'C2xx pipeline has four independent phases. During a given CPU cycle, four different instructions can be active, each at a different stage of completion. See also *instruction-fetch phase*; *instruction-decode phase*; *operand-fetch phase*; *instruction-execute phase*.

PLL: Phase lock loop circuit.

PM bits: See *product shift mode bits (PM)*.

power-down mode: The mode in which the processor enters a dormant state and dissipates considerably less power than during normal operation. This mode is initiated by the execution of an IDLE instruction. During a power-down mode, all internal contents are maintained so that operation continues unaltered when the power-down mode is terminated. The contents of all on-chip RAM also remains unchanged.

PRD: *Timer period register.* A 16-bit memory-mapped register that specifies the main period for the on-chip timer. When the timer counter register (TIM) is decremented past zero, the TIM is loaded with the value in the PRD. See also *TDDR*.

PRDB: See *program read bus (PRDB)*.

PREG: See *product register (PREG)*.

prescaler counter: See *PSC*.

product register (PREG): A 32-bit register that holds the results of a multiply operation.

product shifter: A 32-bit shifter that performs a 0-, 1-, or 4-bit left shift, or a 6-bit right shift of the multiplier product based on the value of the product shift mode bits (PM).

product shift mode: One of four modes (no-shift, shift-left-by-one, shift-left-by-four, or shift-right-by-six) used by the product shifter.

product shift mode bits (PM): Bits 0 and 1 of status register ST1; they identify which of four shift modes (no-shift, left-shift-by-one, left-shift-by-four, or right-shift-by-six) will be used by the product shifter.

program address bus (PAB): A 16-bit internal bus that provides the addresses for program-memory reads and writes.

program-address generation logic: Logic circuitry that generates the addresses for program memory reads and writes, and an operand address in instructions that require two registers to address operands. This circuitry can generate one address per machine cycle. See also *data-address generation logic*.

program control logic: Logic circuitry that decodes instructions, manages the pipeline, stores status of operations, and decodes conditional operations.

program counter (PC): A register that indicates the location of the next instruction to be executed.

program read bus (PRDB): A 16-bit internal bus that carries instruction code and immediate operands, as well as table information, from program memory to the CPU.

\overline{PS} : *Program select pin.* The 'C2xx asserts \overline{PS} to indicate an access to external program memory.

PSC: *Timer prescaler counter.* Bits 9–6 of the timer control register (TCR); specifies the prescale count for the on-chip timer.

PSLWS: *Lower program-space wait-state bits.* A value in the wait-state generator control register (WSGR) that determines the number of wait states applied to reads from and writes to off-chip lower program space (addresses 0000h–7FFFh). PSLWS is not available on the 'C209; instead, see *PSWS*. On other 'C2xx devices, PSLWS is bits 2–0 of the WSGR. See also *PSUWS*.

PSUWS: *Upper program-space wait-state bits.* A value in the wait-state generator control register (WSGR) that determines the number of wait states applied to reads from and writes to off-chip upper program space (addresses 8000h–FFFFh). PSUWS is not available on the 'C209; instead, see *PSWS*. On other 'C2xx devices, PSUWS is bits 5–3 of the WSGR. See also *PSLWS*.

PSWS: *Program-space wait-state bit.* Bit 0 of the 'C209 wait-state generator control register (WSGR). PSWS determines the number of wait states applied to reads from off-chip program memory space.

R

RAMEN: *RAM enable pin.* This pin enables or disables on-chip single-access RAM.

\overline{RD} : *Read select pin.* The 'C2xx asserts \overline{RD} to request a read from external program, data, or I/O space. \overline{RD} can be connected directly to the output enable pin of an external device.

READY: *External device ready pin.* Used to create wait states externally. When this pin is driven low, the 'C2xx waits one CPU cycle and then tests READY again. After READY is driven low, the 'C2xx does not continue processing until READY is driven high.

receive interrupt (asynchronous serial port): An interrupt (TXRXINT) caused during reception by any one of these events: the ADTR holds a new character; overrun occurs; a framing error occurs; a break has been detected on the RX pin; a character *A* or *a* has been detected in the ADTR by the automatic baud-rate detection logic.

receive interrupt (synchronous serial port): See *RINT*.

receive interrupt mask bit (RIM): Bit 7 of the asynchronous serial port control register (ASPCR); enables or disables receive interrupts of the asynchronous serial port.

receive pin (asynchronous serial port): See *RX pin*.

receive pin (synchronous serial port): See *DR pin*.

receive register (asynchronous serial port): See *ADTR*.

receive register (synchronous serial port): See *SDTR*.

receive reset (RRST) bit: Bit 4 of the synchronous serial port control register (SSPCR); resets the receiver portion of the synchronous serial port.

receive shift register (asynchronous serial port): See *ARSR*.

receive shift register (synchronous serial port): See *RSR*.

repeat counter (RPTC): A 16-bit register that counts the number of times a single instruction is repeated. RPTC is loaded by an RPT instruction.

reset: A way to bring the processor to a known state by setting the registers and control bits to predetermined values and signaling execution to start at address 0000h.

reset pin (\overline{RS} , also RS on 'C209): This pin causes a reset.

reset vector: The interrupt vector for reset.

return address: The address of the instruction to be executed when the CPU returns from a subroutine or interrupt service routine.

RFNE bit: *Receive FIFO buffer not empty bit.* Bit 12 of the synchronous serial port control register (SSPCR); indicates whether the receive FIFO buffer of the synchronous serial port contains data to be read.

RIM bit: See *receive interrupt mask bit (RIM)*.

RINT: *Receive interrupt (synchronous serial port).* An interrupt (RINT) generated during reception based on the number of words in the receive FIFO buffer. The trigger condition (the desired number of words in the buffer) is determined by the values of the receive-interrupt bits (FR1 and FR0) of the synchronous serial port control register (SSPCR).

RPTC: See *repeat counter (RPTC)*.

RRST: *Receive reset bit.* Bit 4 of the synchronous serial port control register (SSPCR); resets the receiver portion of the synchronous serial port.

\overline{RS} : *Reset pin.* When driven low, causes a reset on any 'C2xx device, including the 'C209.

RS: *Reset pin.* (On the 'C209 only) When driven high, causes a reset.

RSR: *Receive shift register.* Shifts data serially into the synchronous serial port from the DR pin. See also *XSR*.

\overline{RW} : *Read/write pin.* Indicates the direction of transfer between the 'C2xx and external program, data, or I/O space.

RX pin: *Asynchronous receive pin.* During reception in the asynchronous serial port, this pin accepts a character one bit at a time, transferring it to the ARSR.

S

SARAM: *Single-access RAM.* RAM that can accessed (read from or written to) once in a single CPU cycle.

scratch-pad RAM: Another name for DARAM block B2 in data space (32 words).

SDTR: *Synchronous data transmit and receive register.* An I/O-mapped read/write register that sends data to the transmit FIFO buffer and extracts data from the receive FIFO buffer.

SETBRK: Bit 4 of the asynchronous serial port control register (ASPCR); selects the output level (high or low) on the TX pin when the port is not transmitting.

short-immediate value: An 8-, 9-, or 13-bit constant given as an operand of an instruction that is using immediate addressing.

sign bit: The MSB of a value when it is seen by the CPU to indicate the sign (negative or positive) of the value.

sign extend: Fill the unused high order bits of a register with copies of the sign bit in that register.

sign-extension mode (SXM) bit: Bit 10 of status register ST1; enables or disables sign extension in the input shifter. It also differentiates between logic and arithmetic shifts of the accumulator.

single-access RAM: See *SARAM*.

slave phase: See *latch phase*.

SOFT bit (asynchronous serial port): Bit 14 in the asynchronous serial port control register (ASPCR); a special emulation bit that is used in conjunction with bit 15 (FREE) to determine the state of an asynchronous serial port transfer when a software breakpoint is encountered during emulation. When FREE = 0, SOFT determines the emulation mode. See also *FREE bit (asynchronous serial port)*.

SOFT bit (synchronous serial port): Bit 14 of the synchronous serial port control register (SSPCR); a special emulation bit that is used in conjunction with bit 15 (FREE) to determine the state of a synchronous serial port transfer when a software breakpoint is encountered during emulation. When FREE = 0, SOFT determines the emulation mode. See also *FREE bit (synchronous serial port)*.

SOFT bit (timer): Bit 10 of the timer control register (TCR); a special emulation bit that is used in conjunction with bit 11 (FREE) to determine the state of the timer when a software breakpoint is encountered during emulation. When FREE = 0, SOFT determines the emulation mode. SOFT and FREE are not available in the TCR of the 'C209. See also *FREE bit (timer)*.

software interrupt: An interrupt caused by the execution of an INTR, NMI, or TRAP instruction.

software stack: A program control feature that allows you to extend the hardware stack into data memory with the PSHD and POPD instructions. The stack can be directly stored and recovered from data memory, one word at time. This feature is useful for deep subroutine nesting or protection against stack overflow.

SSPCR: *Synchronous serial port control register.* A 16-bit I/O-mapped register that you write to when setting the configuration of the synchronous serial port and that you read when obtaining the status of the port.

ST0 and ST1: See *status registers ST0 and ST1*.

stack: A block of memory reserved for storing return addresses for subroutines and interrupt service routines. The 'C2xx stack is 16 bits wide and eight levels deep.

start bit: Every 8-bit data value transmitted or received by the asynchronous serial port must be preceded by a start bit, a logic 0 pulse.

status registers ST0 and ST1: Two 16-bit registers that contain bits for determining processor modes, addressing pointer values, and indicating various processor conditions and arithmetic logic results. These registers can be stored into and loaded from data memory, allowing the status of the machine to be saved and restored for subroutines.

STB bit: *Stop bit selector.* Bit 6 of the asynchronous serial port control register (ASPCR); selects the number of stop bits (one or two) used in transmission and reception.

stop bit: Every 8-bit data value transmitted or received by the asynchronous serial port must be followed by one or two stop bits, each a logic 1 pulse. The number of stop bits required depends on the STB bit of the ASPCR.

$\overline{\text{STRB}}$: *External access active strobe.* The 'C2xx asserts $\overline{\text{STRB}}$ during accesses to external program, data, or I/O space.

SXM bit: See *sign-extension mode bit (SXM)*.

T

TC bit: *Test/control flag bit.* Bit 11 of status register ST1; stores the results of test operations done in the central arithmetic logic unit (CALU) or the auxiliary register arithmetic unit (ARAU). The TC bit can be tested by conditional instructions.

TCOMP: *Transmission complete bit.* Bit 13 of the synchronous serial port control register (SSPCR); indicates when all data in the transmit FIFO buffer of the synchronous serial port has been transmitted.

TCR: *Timer control register.* A 16-bit register that controls the operation of the on-chip timer.

TDDR: See *timer divide-down register (TDDR)*.

temporary register (TREG): A 16-bit register that holds one of the operands for a multiply operation; the dynamic shift count for the LACT, ADDT, and SUBT instructions; or the dynamic bit position for the BITT instruction.

TEMT bit: *Transmit empty indicator.* Bit 12 of the I/O status register (IOSR); indicates whether the transmit register (ADTR) and/or the transmit shift register (AXSR) of the asynchronous serial port are full or empty.

THRE bit: *Transmit register empty indicator.* Bit 11 of the I/O status register (IOSR); indicates when the contents of the transmit register (ADTR) are transferred to the transmit shift register (AXSR).

TIM bit: *Transmit interrupt mask bit.* Bit 8 of the asynchronous serial port control register (ASPCR); enables or disables transmit interrupts of the asynchronous serial port.

TIM register: See *timer counter register (TIM)*.

timer counter register (TIM): A 16-bit memory-mapped register that holds the main count for the on-chip timer. See also *timer prescaler counter (PSC)*.

timer divide-down register (TDDR): Bits 3–0 of the timer control register (TCR); specifies the timer divide-down period for the on-chip timer. When the timer prescaler counter (PSC) decrements past zero, the PSC is loaded with the value in the TDDR. See also *timer period register (PRD)*.

timer interrupt (TINT): See *TINT*.

timer period register (PRD): A 16-bit memory-mapped register that specifies the main period for the on-chip timer. When the timer counter register (TIM) is decremented past zero, the TIM is loaded with the value in the PRD. See also *TDDR*.

timer prescaler counter (PSC): Bits 9–6 of the timer control register (TCR); specifies the prescale count for the on-chip timer.

timer reload bit (TRB): Bit 5 of the timer control register (TCR); when TRB is set, the timer counter register (TIM) is loaded with the value of the timer period register (PRD), and the prescaler counter (PSC) is loaded with the value of the timer divide-down register (TDDR).

timer stop status bit (TSS): Bit 4 of the TCR. TSS is used to start and stop the timer.

TINT: *Timer interrupt.* An interrupt generated by the timer on the next CLKOUT1 cycle after the main counter (TIM register) decrements to 0

TOS: *Top of stack.* Top level of the 8-level last-in, first-out hardware stack.

TOUT: *Timer output pin.* Provides access to an output signal based on the rate of the on-chip timer. On the next CLKOUT1 cycle after the main counter (TIM register) decrements to 0, a signal is sent to TOUT.

transmit interrupt (asynchronous serial port): An interrupt (TXRXINT) generated when the transmit register (ADTR) empties during transmission. This condition indicates that the ADTR is ready to accept a new transmit character.

transmit interrupt (synchronous serial port): See *XINT*.

transmit mode (TXM) bit: Bit 3 of the synchronous serial port control register (SSPCR); determines whether the source signal for frame synchronization is external or internal.

transmit pin (asynchronous serial port): See *TX pin*.

transmit pin (synchronous serial port): See *DX pin*.

transmit/receive interrupt (TXRXINT): The CPU interrupt used to respond to a delta interrupt, receive interrupt, or transmit interrupt from the asynchronous serial port. All three of these interrupt types request TXRXINT and use the single TXRXINT interrupt vector. See also *delta interrupt*, *receive interrupt*, *transmit interrupt*.

transmit register (asynchronous serial port): See *ADTR*.

transmit register (synchronous serial port): See *SDTR*.

transmit reset (XRST) bit: Bit 5 of the synchronous serial port control register (SSPCR); resets the transmitter portion of the synchronous serial port.

transmit shift register (asynchronous serial port): Also called AXSR, this register shifts data serially out of the asynchronous serial port through the TX pin. See also *ARSR*.

transmit shift register (synchronous serial port): Also called XSR, this register shifts data serially out of the synchronous serial port through the DX pin. See also *RSR*.

TRB: See *timer reload bit (TRB)*.

TREG: See *temporary register (TREG)*.

TSS bit: See *timer stop status bit (TSS)*.

TTL: *Transistor-to-transistor logic*.

TX pin: *Asynchronous transmit pin*. The pin on which data is transmitted serially from the asynchronous serial port; accepts a character one bit at a time from the transmit shift register (AXSR).

TXM: *Transmit mode bit*. Bit 3 of the synchronous serial port control register (SSPCR); determines whether the source signal for frame synchronization is external or internal.

TXRXINT: See *transmit/receive interrupt (TXRXINT)*.

U

UART: *Universal asynchronous receiver and transmitter*. Used as another name for the asynchronous serial port.

URST: *Reset asynchronous serial port bit.* Bit 13 of the asynchronous serial port control register (ASPCR); resets the asynchronous port.

V

vector: *See interrupt vector.*

vector location: *See interrupt vector location.*

W

wait state: A CLKOUT1 cycle during which the CPU waits when reading from or writing to slower external memory.

wait-state generator: An on-chip peripheral that generates a limited number of wait states for a given off-chip memory space (program, data, or I/O). Wait states are set in the wait-state generator control register (WSGR).

\overline{WE} : *Write enable pin.* The 'C2xx asserts \overline{WE} to request a write to external program, data, or I/O space.

WSGR: *Wait-state generator control register.* This register, which is mapped to I/O memory, controls the wait-state generator.

X

XF bit: *XF-pin status bit.* Bit 4 of status register ST1 that is used to read or change the logic level on the XF pin.

XF pin: *External flag pin.* A general-purpose output pin whose status can be read or changed by way of the XF bit in status register ST1.

XINT: *Transmit interrupt (synchronous serial port).* An interrupt generated during transmission based on the number of words in the transmit FIFO buffer. The trigger condition (the desired number of words in the buffer) is determined by the values of the transmit-interrupt bits (FT1 and FT0) of the synchronous serial port control register (SSPCR).

XRST: *Transmit reset bit.* Bit 5 of the synchronous serial port control register (SSPCR); resets the transmitter portion of the synchronous serial port.

XSR: *Transmit shift register.* Shifts data serially out of the synchronous serial port through the DX pin. See also *RSR*.

Z

zero fill: Fill the unused low or high order bits in a register with zeros.

Index

- * operand 6-10
- *+ operand 6-10
- *- operand 6-10
- *0+ operand 6-10
- *0- operand 6-10
- *BR0+ operand 6-11
- *BR0- operand 6-11
- 14-pin connector, dimensions E-15
- 14-pin header
 - header signals E-2
 - JTAG E-2
- 4-level pipeline operation 5-7

A

- A0–A15 (external address bus)
 - definition 4-3
 - shown in figure 4-6, 4-10, 4-13, 4-15, 4-26
- ABS instruction 7-21
- absolute value (ABS instruction) 7-21
- accumulator
 - definition F-1
 - description 3-9
 - shifting and storing high and low words, diagrams 3-11
- accumulator instructions
 - absolute value of accumulator (ABS) 7-21
 - add PREG to accumulator (APAC) 7-37
 - add PREG to accumulator and load TREG (LTA) 7-93
 - add PREG to accumulator and multiply (MPYA) 7-116
 - add PREG to accumulator and square specified value (SQRA) 7-168
 - add PREG to accumulator, load TREG, and move data (LTD) 7-95
 - accumulator instructions (*continued*)
 - add PREG to accumulator, load TREG, and multiply (MAC) 7-102
 - add PREG to accumulator, load TREG, multiply, and move data (MACD) 7-106
 - add value plus carry to accumulator (ADDC) 7-27
 - add value to accumulator (ADD) 7-23
 - add value to accumulator with shift specified by TREG (ADDT) 7-31
 - add value to accumulator with sign extension suppressed (ADDS) 7-29
 - AND accumulator with value (AND) 7-34
 - branch to location specified by accumulator (BACC) 7-40
 - call subroutine at location specified by accumulator (CALA) 7-58
 - complement accumulator (CMPL) 7-64
 - divide using accumulator (SUBC) 7-180
 - load accumulator (LACC) 7-72
 - load accumulator using shift specified by TREG (LACT) 7-78
 - load accumulator with PREG (PAC) 7-134
 - load accumulator with PREG and load TREG (LTP) 7-98
 - load high bits of accumulator with rounding (ZALR) 7-196
 - load low bits and clear high bits of accumulator (LACL) 7-75
 - negate accumulator (NEG) 7-122
 - normalize accumulator (NORM) 7-126
 - OR accumulator with value (OR) 7-129
 - pop top of stack to low accumulator bits (POP) 7-135
 - push low accumulator bits onto stack (PUSH) 7-141
 - rotate accumulator left by one bit (ROL) 7-144
 - rotate accumulator right by one bit (ROR) 7-145
 - shift accumulator left by one bit (SFL) 7-157
 - shift accumulator right by one bit (SFR) 7-158

- accumulator instructions (*continued*)
 - store high byte of accumulator to data memory (SACH) 7-148
 - store low byte of accumulator to data memory (SACL) 7-150
 - subtract conditionally from accumulator (SUBC) 7-180
 - subtract PREG from accumulator (SPAC) 7-160
 - subtract PREG from accumulator and load TREG (LTS) 7-100
 - subtract PREG from accumulator and multiply (MPYS) 7-118
 - subtract PREG from accumulator and square specified value (SQRS) 7-170
 - subtract value and logical inversion of carry bit from accumulator (SUBB) 7-178
 - subtract value from accumulator (SUB) 7-174
 - subtract value from accumulator with shift specified by TREG (SUBT) 7-184
 - subtract value from accumulator with sign extension suppressed (SUBS) 7-182
 - XOR accumulator with data value (XOR) 7-193
- ADC bit 10-10
- add. *See* accumulator instructions
- ADD instruction 7-23
- ADDC instruction 7-27
- address generation
 - data memory
 - direct addressing* 6-4
 - immediate addressing* 6-2
 - indirect addressing* 6-9
 - program memory 5-2
 - hardware* 5-3
- address maps
 - 'C203 4-32
 - 'C204 4-35
 - 'C209 11-6
 - data page 0 4-8
- address visibility mode (AVIS bit) 11-17
- addressing, bit-reversed indexed 6-10, F-3
- addressing modes
 - definition F-1
 - direct
 - description* 6-4
 - examples* 6-6
 - figure* 6-5
 - opcode format* 6-5 to 6-7
 - role of data page pointer (DP)* 6-4
 - immediate 6-2
- addressing modes (*continued*)
 - indirect
 - description* 6-9
 - effects on auxiliary register pointer (ARP)* 6-14 to 6-16
 - effects on current auxiliary register* 6-14 to 6-16
 - examples* 6-15
 - modifying auxiliary register content* 6-17
 - opcode format* 6-12 to 6-14
 - operands* 6-9
 - operation types* 6-14 to 6-16
 - options* 6-9
 - possible opcodes* 6-14 to 6-16
 - overview 6-1
- ADDS instruction 7-29
- ADDT instruction 7-31
- ADRK instruction 7-33
- ADTR (asynchronous serial port transmit and receive register) 10-4
- AND instruction 7-34
- APAC instruction 7-37
- applications, TMS320 devices 1-4
- ARAU (auxiliary register arithmetic unit) 3-12
- ARAU and related logic, block diagram 3-12
- ARB (auxiliary register pointer buffer) 3-16
- architecture of 'C2x
 - 2-1 to 2-14
- arithmetic instructions. *See* accumulator instructions; auxiliary register instructions
- arithmetic logic unit, central (CALU) 3-9
- ARP (auxiliary register pointer) 3-16
- ARSR (asynchronous serial port receive shift register) 10-5
- ASPCR (asynchronous serial port control register) 10-7
 - configuring pins IO0–IO3 as inputs/outputs 10-15
 - quick reference A-13
- assembly language instructions. *See* instructions
- asynchronous
 - reception 10-20
 - transmission 10-19
- asynchronous serial port
 - See also* asynchronous serial port registers
 - basic operation 10-6
 - baud rates
 - common* 10-14
 - setting* 10-13

- asynchronous serial port (*continued*)
 - baud-rate detection logic
 - detecting A or a character (ADC bit)* 10-10
 - enabling/disabling (CAD bit)* 10-8
 - block diagram 10-3
 - components 10-3
 - configuration 10-7
 - delta interrupts 10-17
 - enabling/disabling (DIM bit)* 10-8
 - emulation modes (FREE and SOFT bits) 10-7
 - features 10-1
 - interrupts (TXRXINTs)
 - flag bit (TXRXINT)* 5-21
 - introduction* 10-5
 - mask bit in IMR (TXRXINT)* 5-23
 - mask bits in ASPCR (DIM, TIM, RIM)* 10-8
 - priority* 5-16
 - three types* 10-17
 - vector location* 5-16
 - introduction 2-12
 - overrun in receiver, detecting (OE bit) 10-11
 - overview 10-2
 - receive interrupts 10-17
 - enabling/disabling (RIM bit)* 10-8
 - receive pin (RX)
 - definition* 10-4
 - detecting break on (BI bit)* 10-10
 - receiver operation 10-20
 - reset conditions 5-34
 - resetting (URST bit) 10-7
 - signals 10-3
 - data* 10-3
 - handshake* 10-3
 - stop bit(s)
 - detecting invalid (FE bit)* 10-11
 - setting number of (STB bit)* 10-8
 - transmit interrupts 10-17
 - enabling/disabling (TIM bit)* 10-8
 - transmit pin (TX)
 - definition* 10-4
 - output level between transmissions (SETBRK bit)* 10-8
 - transmitter operation 10-19
- asynchronous serial port registers
 - baud-rate divisor register (BRD) 10-13
 - control register (ASPCR) 10-7
 - configuring pins IO0–IO3 as inputs/outputs* 10-15
 - quick reference* A-13
- asynchronous serial port registers (*continued*)
 - I/O status register (IOSR)
 - description* 10-10
 - quick reference* A-13
 - introduction 10-4
 - receive register (ADTR)
 - detecting overrun in (OE bit)* 10-11
 - detecting when empty (DR bit)* 10-11
 - receive shift register (ARSR) 10-5
 - receive/transmit register (ADTR) 10-4
 - transmit register (ADTR)
 - detecting when empty (THRE bit)* 10-11
 - detecting when it and AXSR are empty (TEMT bit)* 10-10
 - transmit shift register (AXSR) 10-5
 - detecting when it and ADTR are empty (TEMT bit)* 10-10
 - transmit/receive register (ADTR) 10-4
 - automatic baud-rate detection 10-14
 - auxiliary register arithmetic unit (ARAU), description 3-12
 - auxiliary register instructions
 - add short immediate value to current auxiliary register (ADRK) 7-33
 - branch if current auxiliary register not zero (BANZ) 7-41
 - compare current auxiliary register with AR0 (CMPR) 7-65
 - load specified auxiliary register (LAR) 7-80
 - modify auxiliary register pointer (MAR) 7-111
 - modify current auxiliary register (MAR) 7-111
 - store specified auxiliary register (SAR) 7-152
 - subtract short immediate value from current auxiliary register (SBRK) 7-154
 - auxiliary register pointer (ARP) 3-16, F-2
 - auxiliary register pointer buffer (ARB) 3-16, F-2
 - auxiliary register update (ARU) code 6-13
 - auxiliary registers (AR0–AR7)
 - block diagram 3-12
 - current auxiliary register 6-9
 - role in indirect addressing* 6-9 to 6-18
 - update code (ARU)* 6-13
 - description 3-12 to 3-14
 - general uses for 3-14
 - instructions that modify content 6-17
 - next auxiliary register 6-11
 - used in indirect addressing 3-12
 - AVIS bit 11-17
 - AXSR (asynchronous serial port transmit shift register) 10-5

B

- B instruction 7-39
- BACC instruction 7-40
- BANZ instruction 7-41
- baud-rate
 - detection procedure 10-14
 - divisor register (BRD) 10-13
 - generator 10-4
- BCND instruction 7-43
- BI bit 10-10
- $\overline{\text{BIO}}$ pin 8-17 to 8-18
- BIT instruction 7-45
- bit-reversed indexed addressing 6-10, F-3
- BITT instruction 7-47
- BLDD instruction 7-49
- block diagrams
 - 'C2xx overall 2-2
 - ARAU and related logic 3-12
 - arithmetic logic section of CPU 3-8
 - asynchronous serial port 10-3
 - auxiliary registers (AR0–AR7) and ARAU 3-12
 - bus structure 2-4
 - CPU (selected sections) 3-2
 - input scaling section of CPU 3-3
 - multiplication section of CPU 3-5
 - program-address generation 5-2
 - synchronous serial port 9-3
 - timer 8-8
- block move instructions
 - block move from data memory to data memory (BLDD) 7-49
 - block move from program memory to data memory (BLPD) 7-54
- BLPD instruction 7-54
- Boolean logic instructions
 - AND 7-34
 - CMPL (complement/NOT) 7-64
 - OR 7-129
 - XOR (exclusive OR) 7-193
- $\overline{\text{BOOT}}$ (boot load pin), definition 4-4
- boot loader 4-14 to 4-22
 - boot source (EPROM)
 - choosing an EPROM 4-14
 - connecting the EPROM 4-15
 - programming the EPROM 4-16
 - diagram 4-14 to 4-22
 - enabling 4-17
 - execution 4-18
 - generating code for EPROM C-23 to C-24
 - program code 4-21
- $\overline{\text{BR}}$ (bus request pin)
 - definition 4-3
 - shown in figure 4-13, 4-15
- branch instructions
 - branch conditionally (BCND) 7-43
 - branch if current auxiliary register not zero (BANZ) 7-41
 - branch to location specified by accumulator (BACC) 7-40
 - branch to NMI interrupt vector location (NMI) 7-124
 - branch to specified interrupt vector location (INTR) 7-71
 - branch to TRAP interrupt vector location (TRAP) 7-192
 - branch unconditionally (B) 7-39
 - call subroutine at location specified by accumulator (CALA) 7-58
 - call subroutine conditionally (CC) 7-60
 - call subroutine unconditionally (CALL) 7-59
 - conditional, overview 5-11
 - return conditionally from subroutine (RETC) 7-143
 - return unconditionally from subroutine (RET) 7-142
 - unconditional, overview 5-8
- BRD (baud-rate divisor register) 10-13
- buffered signals, JTAG E-10
- buffering E-10
- burst mode
 - definition F-3
 - error conditions 9-29
 - reception 9-24
 - transmission
 - with external frame sync 9-18
 - with internal frame sync 9-16
- bus devices E-4
- bus protocol in emulator system E-4

bus request pin ($\overline{\text{BR}}$)

definition 4-3

shown in figure 4-13, 4-15

buses

block diagram 2-4

data read bus (DRDB) 2-3

data write bus (DWEB) 2-3

data-read address bus (DRAB) 2-3

data-write address bus (DWAB) 2-3

program address bus (PAB)

definition 2-3

used in program-memory address generation 5-3

program read bus (PRDB) 2-3

C

C (carry bit)

affected during SFL and SFR instructions 7-157 to 7-159

definition 3-16

involved in accumulator events 3-10

used during ROL and ROR instructions 7-144 to 7-146

'C209 device 11-1 to 11-18

comparison to other 'C2xx devices 11-2

differences in interrupts 11-3*differences in memory and I/O spaces* 11-3*differences in peripherals* 11-2*similarities* 11-2

interrupts 11-10

locating 'C209 information in this manual (table) 11-3

memory and I/O spaces 11-5

on-chip peripherals 11-14

cable, target system to emulator E-1 to E-25

cable pod E-5, E-6

CAD bit 10-8

CALA instruction 7-58

CALL instruction 7-59

call instructions

call subroutine at location specified by accumulator (CALA) 7-58

call subroutine conditionally (CC) 7-60

call subroutine unconditionally (CALL) 7-59

conditional, overview 5-12

unconditional, overview 5-8

CALU (central arithmetic logic unit)

definition F-4

description 3-9

carry bit (C)

affected during SFL and SFR instructions 7-157 to 7-159

definition 3-16

involved in accumulator events 3-10

used during ROL and ROR instructions 7-144 to 7-146

CC instruction 7-60

central arithmetic logic section of CPU 3-8

central arithmetic logic unit (CALU). See CALU

central processing unit. See CPU

CIO0–CIO3 (bits), configuring pins IO0–IO3 as inputs/outputs 10-15

CLK register

description 8-7

quick reference A-11

reset condition 5-34

CLKIN signal 8-4 to 8-6

CLKMOD pin 11-14, F-4

CLKOUT1 bit 8-7

CLKOUT1 signal 8-4 to 8-6

definition F-4

turning CLKOUT1 pin on and off 8-7

CLKOUT1-pin control (CLK) register

description 8-7

quick reference A-11

reset condition 5-34

CLKR pin

as bit input (IN0 bit) 9-10

definition 9-4

CLKX pin 9-4

clock generator 8-4 to 8-6

'C209 clock options 11-14 to 11-18

introduction 2-11

modes

'C203/C204 8-5

'C209 11-14 to 11-18

clock mode bit (MCM) 9-11

clock modes

clock generator

'C203/C204 8-5

'C209 11-14

synchronous serial port 9-11

CLRC instruction 7-62

CMPL instruction 7-64

- CMPR instruction 7-65
- CNF (DARAM configuration bit) 3-16
- code compatibility 1-6
- codec, definition F-5
- conditional instructions 5-10 to 5-13
 - conditional branch 5-11 to 5-13
 - conditional call 5-12 to 5-13
 - conditional return 5-12 to 5-13
 - conditions that may be tested 5-10
 - stabilization of conditions 5-11
 - using multiple conditions 5-10
- configuration
 - memory
 - global data* 4-11
 - RAM (dual-access)*
 - 'C203 4-33
 - 'C204 4-36
 - 'C209 11-8
 - RAM (single-access)* 11-7
 - ROM*
 - 'C204 4-36
 - 'C209 11-7
 - multiprocessor E-13
- connector
 - 14-pin header E-2
 - dimensions, mechanical E-14
 - DuPont E-2
- continuous mode
 - error conditions 9-29
 - reception 9-25
 - transmission
 - with external frame sync* 9-22
 - with internal frame sync* 9-20
- control instructions (summary) 7-9
- CPU 3-1 to 3-18
 - accumulator 3-9
 - arithmetic logic section 3-8
 - auxiliary register arithmetic unit (ARAU) 3-12
 - block diagram (partial) 3-2
 - CALU (central arithmetic logic unit) 3-9
 - central arithmetic logic unit (CALU) 3-9
 - definition F-5
 - input scaling section/input shifter 3-3
 - key features 1-6
 - multiplication section 3-5
 - output shifter 3-11
 - overview 2-5
 - CPU (*continued*)
 - product shifter 3-6
 - product shift modes* 3-7
 - status registers ST0 and ST1 3-15
 - current auxiliary register 6-9
 - add short immediate value to (ADRK instruction) 7-33
 - branch if not zero (BANZ instruction) 7-41
 - compare with AR0 (CMPR instruction) 7-65
 - increment or decrement (MAR instruction) 7-111
 - role in indirect addressing 6-9 to 6-18
 - subtract short immediate value from (SBRK instruction) 7-154
 - update code (ARU) 6-13
- D**
 - D0–D15 (external data bus)
 - definition 4-3, F-6
 - shown in figure 4-6, 4-10, 4-13, 4-15, 4-26
 - DARAM (dual-access RAM)
 - configuration
 - 'C203 4-33
 - 'C204 4-36
 - 'C209 11-8
 - description 2-7
 - DARAM configuration bit (CNF) 3-16
 - data memory
 - address map
 - 'C203 4-32
 - 'C204 4-35
 - 'C209 11-6
 - data page 0* 4-8
 - caution about reserved addresses 4-33, 4-36, 11-7
 - configuration
 - RAM (dual-access)*
 - 'C203 4-33
 - 'C204 4-36
 - 'C209 11-8
 - RAM (single-access)* 11-7
 - data page pointer (DP) 3-16
 - external interfacing
 - caution about proper timing* 4-9
 - global* 4-12
 - local* 4-9
 - global 4-11
 - local 4-7
 - on-chip registers mapped to 4-8

- data memory select pin (\overline{DS})
 - definition 4-3
 - shown in figure 4-10, 4-13
 - data page 0 4-8
 - caution about test/emulation addresses 4-8
 - data page pointer (DP)
 - caution about initializing DP 6-5
 - definition 3-16
 - load (LDP instruction) 7-83
 - role in direct addressing 6-4
 - data read bus (DRDB) 2-3
 - data write bus (DWEB) 2-3
 - data-read address bus (DRAB) 2-3
 - data-scaling shifter
 - at input of CALU 3-3
 - at output of CALU 3-11
 - data-write address bus (DWAB) 2-3
 - delta interrupts
 - description 10-17
 - enabling/disabling (DIM bit) 10-8
 - device reset 5-33
 - diagnostic applications E-24
 - digital loopback mode 9-28
 - DIM bit 10-8
 - dimensions
 - 12-pin header E-20
 - 14-pin header E-14
 - mechanical, 14-pin header E-14
 - DIO0–DIO3 (bits), detecting change on pins
 - IO0–IO3 10-16
 - direct addressing
 - description 6-4
 - examples 6-6
 - figure 6-5
 - opcode format 6-5 to 6-7
 - role of data page pointer (DP) 6-4
 - direct memory access (using HOLD operation) 4-27
 - during reset 4-29
 - example 4-28
 - terminating correctly 4-29
 - DIV1 and DIV2 pins 8-5, F-7
 - divide (SUBC instruction) 7-180
 - DLB bit 9-12
 - DMOV instruction 7-66
 - DP (data page pointer)
 - caution about initializing DP 6-5
 - definition 3-16
 - load (LDP instruction) 7-83
 - role in direct addressing 6-4
 - DR bit 10-11
 - DR pin 9-4
 - DRAB (data-read address bus) 2-3
 - DRDB (data read bus) 2-3
 - \overline{DS} (data memory select pin)
 - definition 4-3
 - shown in figure 4-10, 4-13
 - DSWS bit(s)
 - 'C203/C204 8-15
 - 'C209 11-17
 - dual-access RAM (DARAM) F-6
 - configuration
 - 'C203 4-33
 - 'C204 4-36
 - 'C209 11-8
 - description 2-7
 - DuPont connector E-2
 - DWAB (data-write address bus) 2-3
 - DWEB (data write bus) 2-3
 - DX pin 9-4
- ## E
- EMU0/1
 - configuration E-21, E-23, E-24
 - emulation pins E-20
 - IN signals E-21
 - rising edge modification E-22
 - EMU0/1 signals E-2, E-3, E-6, E-7, E-13, E-18
 - emulation
 - configuring multiple processors E-13
 - JTAG cable E-1
 - pins E-20
 - timing calculations E-7 to E-9, E-18 to E-26
 - using scan path linkers E-16
 - emulation capability 2-13
 - emulation modes (FREE and SOFT bits)
 - asynchronous serial port 10-7
 - synchronous serial port 9-8
 - timer 8-11
 - emulation timing E-7

emulator

- cable pod E-5
- connection to target system, JTAG mechanical
 - dimensions E-14 to E-25
- designing the JTAG cable E-1
- emulation pins E-20
- pod interface E-5
- pod timings E-6
- signal buffering E-10 to E-13
- target cable, header design E-2 to E-3

enhanced instructions B-5

error conditions

- asynchronous serial port
 - framing error (FE bit) 10-11
 - overrun (OE bit) 10-11
- synchronous serial port
 - burst mode 9-29
 - continuous mode 9-29

examples of 'C2xx program code C-1 to C-24

external access active strobe ($\overline{\text{STRB}}$) 4-3

external address bus (A0–A15)

- definition 4-3
- shown in figure 4-6, 4-10, 4-13, 4-15, 4-26

external data bus (D0–D15)

- definition 4-3
- shown in figure 4-6, 4-10, 4-13, 4-15, 4-26

external device ready pin (READY)

- definition 4-4
- generating wait states with 8-14

external interfacing, diagrams 4-6, 4-10, 4-13, 4-26

external oscillator, using (diagram) 8-5

F

FE bit 10-11

features summary 1-6

FIFO buffers, introduction 9-5

FINT2 bit 5-26

FINT3 bit 5-26

flag bits

- I/O status register (IOSR) 10-10
- interrupt control register (ICR) 5-18
- interrupt flag register (IFR) 5-18

flash memory (on-chip), introduction 2-9

flow charts

- interrupt operation
 - maskable interrupts 5-20
 - nonmaskable interrupts 5-29
 - requesting $\overline{\text{INT2}}$ and $\overline{\text{INT3}}$ 5-18
- TMS320 ROM code submittal D-2

4-level pipeline operation 5-7

14-pin connector, dimensions E-15

14-pin header

- header signals E-2
- JTAG E-2

FR1 and FR0 bits 9-10

frame synchronization mode (FSM bit) 9-11

framing error (FE bit) 10-11

FREE bit

- asynchronous serial port 10-7
- synchronous serial port 9-8
- timer 8-11

FSM bit 9-11

FSR pin 9-4

FSX pin 9-4

FT1 and FT0 bits 9-9

G

general-purpose I/O pins 8-17 to 8-20

input

- $\overline{\text{BIO}}$ 8-17 to 8-18
- IO0–IO3 10-15 to 10-16

output

- IO0–IO3 10-15 to 10-16
- XF 8-18

generating executable files, figure C-2

generating wait states with 8-14

generators (on-chip)

- baud-rate generator 10-4
- clock generator 8-4 to 8-6
- 'C209 clock options 11-14 to 11-18
- wait-state generator 8-14 to 8-16
- 'C209 11-16 to 11-18

global data memory 4-11

- configuration 4-11
- external interfacing 4-12

global memory allocation register (GREG) 4-11

GREG (global memory allocation register) 4-11

H

- hardware interrupts
 - definition 5-15
 - nonmaskable external 5-27
 - priorities 5-16
 - types 5-15
- hardware reset 5-33
- header
 - 14-pin E-2
 - dimensions, 14-pin E-2
- $\overline{\text{HOLD}}$ (HOLD operation request pin)
 - definition 4-4
 - use in HOLD operation 4-27
- HOLD acknowledge pin ($\overline{\text{HOLDA}}$)
 - definition 4-4
 - use in HOLD operation 4-27
- HOLD operation
 - description 4-27
 - during reset 4-29
 - example 4-28
 - terminating correctly 4-29
- HOLD operation request pin ($\overline{\text{HOLD}}$)
 - definition 4-4
 - use in HOLD operation 4-27
- HOLD/INT1 bit
 - in interrupt flag register (IFR) 5-22
 - in interrupt mask register (IMR) 5-24
- $\overline{\text{HOLD/INT1}}$ interrupt
 - flag bit 5-22
 - mask bit 5-24
 - priority 5-16
 - vector location 5-16
- $\overline{\text{HOLD/INT1}}$ pin, mode set by MODE bit 5-24
- $\overline{\text{HOLDA}}$ (HOLD acknowledge pin)
 - definition 4-4
 - use in HOLD operation 4-27

I

- I/O
 - general-purpose pins
 - input*
 - BIO 8-17 to 8-18
 - IO0–IO3 10-15 to 10-16
 - output*
 - IO0–IO3 10-15 to 10-16
 - XF 8-18
- I/O (continued)
 - parallel ports 4-25
 - serial ports
 - asynchronous* 10-1 to 10-20
 - introduction* 2-12
 - synchronous* 9-1 to 9-30
- I/O space
 - accessing 4-25
 - address map 4-23
 - caution about reserved addresses 4-24
 - description 4-23
 - external interfacing 4-25
 - instructions
 - transfer data from data memory to I/O space (OUT)* 7-132
 - transfer data from I/O space to data memory (IN)* 7-69
 - on-chip registers mapped to
 - 'C203/C204 4-24
 - 'C209 11-9
 - accessing* 4-25
 - pins for external interfacing 4-3
- I/O space select pin ($\overline{\text{IS}}$)
 - definition 4-3
 - shown in figure 4-26
- I/O status register (IOSR)
 - description 10-10
 - detecting change on pins IO0–IO3 10-16
 - quick reference A-14
 - reading current logic level on pins IO0–IO3 10-16
- I/O-mapped registers, addresses and reset values A-2
- $\overline{\text{IACK}}$ signal 11-13
- ICR (interrupt control register) 5-24 to 5-38
 - bits 5-26
 - quick reference A-8
- IDLE instruction 7-68
- IEEE 1149.1 specification, bus slave device rules E-4
- IFR (interrupt flag register) 5-20 to 5-38
 - bits
 - 'C203/C204 5-21
 - 'C209 11-12
 - clearing interrupts 5-20
 - quick reference A-6
- immediate addressing 6-2

- IMR (interrupt mask register) 5-22 to 5-38
 - bits
 - 'C203/C204 5-23
 - 'C209 11-13
 - in interrupt acknowledgement process 5-19
 - quick reference A-7
- IN instruction 7-69
- IN0 bit 9-10
- indirect addressing
 - description 6-9
 - effects on auxiliary register pointer (ARP) 6-14 to 6-16
 - effects on current auxiliary register 6-14 to 6-16
 - examples 6-15
 - modifying auxiliary register content 6-17
 - opcode format 6-12 to 6-14
 - operands 6-10
 - operation types 6-14 to 6-16
 - options 6-9
 - possible opcodes 6-14 to 6-16
- input clock modes
 - 'C203/C204 8-5
 - 'C209 11-14
- input scaling section of CPU 3-3
- input shifter 3-3
- input/output space. *See* I/O space
- input/output status register (IOSR)
 - description 10-10
 - detecting change on pins IO0–IO3 10-16
 - reading current logic level on pins IO0–IO3 10-16
- instruction register (IR), definition F-11
- instruction set, key features 1-7
- instructions 7-1 to 7-20
 - Boolean logic
 - AND 7-34
 - CMPL (*complement/NOT*) 7-64
 - OR 7-129
 - XOR (*exclusive OR*) 7-193
 - compared with those of other TMS320 devices B-1 to B-36
 - conditional 5-10 to 5-13
 - branch (BCND) 7-43
 - call (CC) 7-60
 - conditions that may be tested 5-10
 - return (RETC) 7-143
 - stabilization of conditions 5-11
 - using multiple conditions 5-10
- instructions (*continued*)
 - CPU halt until hardware interrupt (IDLE) 7-68
 - delay/no operation (NOP) 7-125
 - descriptions 7-20
 - how to use 7-12
 - enhanced B-5
 - idle until hardware interrupt (IDLE) 7-68
 - interrupt
 - branch to $\overline{\text{NMI}}$ interrupt vector location (NMI) 7-124
 - branch to specified interrupt vector location (INTR) 7-71
 - branch to TRAP interrupt vector location (TRAP) 7-192
 - negate accumulator (NEG) 7-122
 - no operation (NOP) 7-125
 - normalize (NORM) 7-126
 - OR 7-129
 - power down until hardware interrupt (IDLE) 7-68
 - repeat next instruction n times
 - description (RPT) 7-146
 - introduction 5-14
 - stack
 - pop top of stack to data memory (POPD) 7-137
 - pop top of stack to low accumulator bits (POP) 7-135
 - push data memory value onto stack (PSHD) 7-139
 - push low accumulator bits onto stack (PUSH) 7-141
 - status registers ST0 and ST1
 - clear control bit (CLRC) 7-62
 - load (LST) 7-87
 - load data page pointer (LDP) 7-83
 - modify auxiliary register pointer (MAR) 7-111
 - set control bit (SETC) 7-155
 - set product shift mode (SPM) 7-167
 - store (SST) 7-172
 - summary 7-2 to 7-11
 - test bit specified by TREG (BITT) 7-47
 - test specified bit (BIT) 7-45
- INT1 bit ('C209)
 - in interrupt flag register (IFR) 11-12
 - in interrupt mask register (IMR) 11-13

INT1 interrupt

'C203/C204

- flag bit (HOLD/INT1)* 5-22
- mask bit (HOLD/INT1)* 5-24
- priority* 5-16
- vector location* 5-16

'C209

- flag bit* 11-12
- mask bit* 11-13
- priority* 11-10
- vector location* 11-10

INT2 bit ('C209)

- in interrupt flag register (IFR) 11-12
- in interrupt mask register (IMR) 11-13

INT2 interrupt

'C203/C204

- flag bits*
 - FINT2 5-26
 - INT2/INT3 5-22
- masking/unmasking in ICR* 5-27
- masking/unmasking in IMR* 5-23
- priority* 5-16
- vector location* 5-16

'C209

- flag bit* 11-12
- mask bit* 11-13
- priority* 11-10
- vector location* 11-10

INT2/INT3 bit

- in interrupt flag register (IFR) 5-22
- in interrupt mask register (IMR) 5-23

INT20–INT31 (interrupts), vector locations

'C203/C204 5-17

'C209 11-11

INT3 bit ('C209)

- in interrupt flag register (IFR) 11-12
- in interrupt mask register (IMR) 11-13

INT3 interrupt

'C203/C204

- flag bits*
 - FINT3 5-26
 - INT2/INT3 5-22
- masking/unmasking in ICR* 5-26
- masking/unmasking in IMR* 5-23
- priority* 5-16
- vector location* 5-16

INT3 interrupt (*continued*)

'C209

- flag bit* 11-12
- mask bit* 11-13
- priority* 11-10
- vector location* 11-10

INT8–INT16 (interrupts), vector locations

'C203/C204 5-16 to 5-17

'C209 11-10

interfacing

- to external global data memory 4-12
- to external I/O space 4-25
- to external local data memory 4-9
- to external program memory 4-5

internal oscillator, using (diagram) 8-4

interrupt 5-15 to 5-32

definitions 5-15, F-12

hardware interrupt

definition 5-15*priorities*

'C203/C204 5-16

'C209 11-10

interrupt mode bit (INTM) 3-16

use in enabling/disabling maskable interrupts 5-19

interrupt service routines (ISRs) 5-29 to 5-30

ISRs within ISRs 5-30*saving and restoring context* 5-29 to 5-30

latency 5-30 to 5-36

after execution of RET 5-32*during execution of CLRC INTM* 5-31*minimum latency* 5-30

maskable interrupt 5-18 to 5-20

acknowledgement conditions 5-19*definition* 5-15*enabling/disabling with INTM bit* 5-19*flag bits in ICR* 5-24*flag bits in IFR* 5-20*flow chart of operation* 5-20*flow chart of requesting INT2 and INT3* 5-18*interrupt mode bit (INTM)* 3-16*masking/unmasking in ICR* 5-24 to 5-38*masking/unmasking in IMR* 5-22 to 5-38

nonmaskable interrupt 5-27 to 5-29

definition 5-15*flow chart of operation* 5-29*hardware-initiated* 5-27*software-initiated* 5-27

operation (three phases) 5-15

pending interrupt (IFR flag set) 5-20 to 5-22

- interrupt (*continued*)
 - phases of operation 5-15
 - priorities
 - 'C203/C204 5-16
 - 'C209 11-10
 - in interrupt acknowledgement process 5-19
 - registers
 - interrupt control register (ICR) 5-24
 - interrupt flag register (IFR) 5-20 to 5-22
 - 'C209 11-12
 - interrupt mask register (IMR) 5-22 to 5-24
 - 'C209 11-13
 - software interrupt
 - definition 5-15
 - instructions 5-27
 - special cases
 - clearing ICR flag bits 5-25
 - clearing IFR flag bit after INTR instruction 5-21
 - clearing IFR flag bits set by serial port interrupts 5-21
 - controlling INT2 and INT3 with ICR 5-24
 - requesting INT2 and INT3 5-18
 - table 5-16
 - vector locations
 - 'C203/C204 5-16
 - 'C209 11-10
- interrupt acknowledge signal (IACK) 11-13
- interrupt control register (ICR) 5-24 to 5-38
 - bits 5-26
 - quick reference A-8
- interrupt flag register (IFR) 5-20 to 5-38
 - bits
 - 'C203/C204 5-21
 - 'C209 11-12
 - clearing interrupts 5-20
 - quick reference A-6
- interrupt latency
 - definition F-12
 - description 5-30
- interrupt mask register (IMR) 5-22 to 5-38
 - bits
 - 'C203/C204 5-23
 - 'C209 11-13
 - in interrupt acknowledgement process 5-19
 - quick reference A-7
- interrupt mode bit (INTM) 3-16
- interrupt phases of operation 5-15
- interrupt service routines (ISRs) 5-29
 - definition F-12
 - ISRs within ISRs 5-30
 - saving and restoring context 5-29
- INTM (interrupt mode bit) 3-16
 - effect on power-down mode 5-36
 - in interrupt acknowledgement process 5-19
- INTR instruction 7-71
 - introduction 5-27
 - operand (K) values
 - 'C203/C204 5-16
 - 'C209 11-10
- introduction
 - TMS320 devices 1-2
 - TMS320C2xx devices 1-5
- IO0–IO3 (bits) 10-13
 - reading current logic level on pins IO0–IO3 10-16
- IO0–IO3 (pins) 10-15 to 10-17
- IOSR (I/O status register)
 - detecting change on pins IO0–IO3 10-16
 - quick reference A-14
 - reading current logic level on pins IO0–IO3 10-16
- IR (instruction register), definition F-11
- IS (I/O space select pin)
 - definition 4-3
 - shown in figure 4-26
- ISR (interrupt service routine) 5-29 to 5-30
 - definition F-12
 - ISRs within ISRs 5-30
 - saving and restoring context 5-29 to 5-30
- ISWS bit(s)
 - 'C203/C204 8-15
 - 'C209 11-17

J

- JTAG E-16
- JTAG emulator
 - buffered signals E-10
 - connection to target system E-1 to E-25
 - no signal buffering E-10

K

- key features of the 'C2x 1-6

L

- LACC instruction 7-72
- LACL instruction 7-75
- LACT instruction 7-78
- LAR instruction 7-80
- latch phase of CPU cycle F-13
- latency, interrupt 5-30 to 5-36
 - after execution of RET 5-32
 - during execution of CLRC INTM 5-31
 - minimum latency 5-30
- LDP instruction 7-83
- local data memory
 - address map
 - 'C203 4-32
 - 'C204 4-35
 - 'C209 11-6
 - configuration
 - RAM (dual-access)
 - 'C203 4-33
 - 'C204 4-36
 - 'C209 11-8
 - RAM (single-access) 11-7
 - description 4-7
 - external interfacing 4-9
 - caution about proper timing 4-9
 - pages of (diagram) 4-7
- logic instructions
 - AND 7-34
 - CMPL (complement/NOT) 7-64
 - OR 7-129
 - XOR (exclusive OR) 7-193
- logic phase of CPU cycle F-13
- long immediate addressing 6-2
- LPH instruction 7-85
- LST instruction 7-87
- LT instruction 7-91
- LTA instruction 7-93
- LTD instruction 7-95
- LTP instruction 7-98
- LTS instruction 7-100

M

- MAC instruction 7-102
- MACD instruction 7-106
- MAR instruction 7-111

- mask bits
 - asynchronous serial port control register (ASPCR) 10-8
 - interrupt control register (ICR) 5-24
 - interrupt mask register (IMR) 5-22
- maskable interrupts 5-18
 - acknowledgement conditions 5-19
 - definition 5-15
 - enabling/disabling with INTM bit 5-19
 - flag bits in ICR 5-24
 - flag bits in IFR 5-20
 - flow chart of operation 5-20
 - flow chart of requesting INT2 and INT3 5-18
 - masking/unmasking in ICR 5-24
 - masking/unmasking in IMR 5-22
- MCM bit 9-11
- memory
 - See also I/O space
 - address map
 - 'C203 4-32
 - 'C204 4-35
 - 'C209 11-6
 - data page 0 4-8
 - available on TMS320C2xx devices 2-7
 - available types 1-6
 - boot loader 4-14
 - boot source (EPROM) 4-14
 - diagram 4-14
 - enabling 4-17
 - execution 4-18
 - generating code for EPROM C-23 to C-24
 - program code 4-21
 - data page pointer (DP) 3-16
 - device-specific information 4-31
 - direct memory access (using HOLD operation) 4-27
 - during reset 4-29
 - example 4-28
 - terminating correctly 4-29
 - external interfacing
 - global data memory 4-12
 - I/O ports 4-25
 - local data memory 4-9
 - program memory 4-5
 - flash, introduction 2-9
 - global data memory 4-11 to 4-13
 - HOLD operation 4-27 to 4-30
 - during reset 4-29
 - example 4-28
 - terminating correctly 4-29

- memory (*continued*)
 - introduction 4-2
 - local data memory
 - description* 4-7 to 4-10
 - pages of (diagram)* 4-7
 - on-chip memory, advantages 4-2
 - organization 4-2
 - overview 2-7
 - pins for external interfacing 4-3
 - program memory 4-5 to 4-6
 - address generation logic* 5-2
 - address sources* 5-3
 - RAM (dual-access)
 - configuration*
 - 'C203 4-33
 - 'C204 4-36
 - 'C209 11-8
 - description* 2-7
 - RAM (single-access)
 - configuration* 11-7
 - description* 2-8
 - reset conditions 5-33
 - ROM
 - configuration*
 - 'C204 4-36
 - 'C209 11-7
 - introduction* 2-8
- memory instructions
 - block move from data memory to data memory (BLDD) 7-49
 - block move from program memory to data memory (BLPD) 7-54
 - move data after add PREG to accumulator, load TREG, and multiply (MACD) 7-106
 - move data to next higher address in data memory (DMOV) 7-66
 - move data, load TREG, and add PREG to accumulator (LTD) 7-95
 - store long immediate value to data memory (SPLK) 7-165
 - table read (TBLR) 7-186
 - table write (TBLW) 7-189
 - transfer data from data memory to I/O space (OUT) 7-132
 - transfer data from I/O space to data memory (IN) 7-69
 - transfer word from data memory to program memory (TBLW) 7-189
 - transfer word from program memory to data memory (TBLR) 7-186
- memory-mapped registers, addresses and reset values A-2
- micro stack (MSTACK) 5-6
- microprocessor/microcomputer pin (MP/MC)
 - definition 4-4
 - use in configuring memory
 - 'C204 4-36
 - 'C209 11-7
- MINT2 bit 5-27
- MINT3 bit 5-26
- MODE bit 5-26
 - used in HOLD operation 4-27
- MP/MC (microprocessor/microcomputer pin)
 - definition 4-4
 - use in configuring memory
 - 'C204 4-36
 - 'C209 11-7
- MPY instruction 7-113
- MPYA instruction 7-116
- MPYS instruction 7-118
- MPYU instruction 7-120
- MSTACK (micro stack) 5-6
- multicycle instructions 5-31
- multiplication section of CPU 3-5
- multiplier
 - description* 3-5
 - introduction* 2-6
- multiply instructions
 - multiply (include load to TREG) and accumulate previous product (MAC) 7-102
 - multiply (include load to TREG), accumulate previous product, and move data (MACD) 7-106
 - multiply (MPY) 7-113
 - multiply and accumulate previous product (MPYA) 7-116
 - multiply and subtract previous product (MPYS) 7-118
 - multiply unsigned (MPYU) 7-120
 - square specified value after accumulating previous product (SQRA) 7-168
 - square specified value after subtracting previous product from accumulator (SQRS) 7-170

N

- NEG instruction 7-122
- next auxiliary register 6-11

next program address register (NPAR)
 definition F-15
 shown in figure 5-2

NMI hardware interrupt
 description 5-27
 priority
 'C203/C204 5-17
 'C209 11-11
 vector location
 'C203/C204 5-17
 'C209 11-11

NMI instruction 7-124
 introduction 5-28
 vector location
 'C203/C204 5-17
 'C209 11-11

nonmaskable interrupts 5-27
 definition 5-15
 flow chart of operation 5-29
 hardware-initiated 5-27
 software-initiated 5-27

NOP instruction 7-125

NORM instruction 7-126

NPAR (next program address register)
 definition F-15
 shown in figure 5-2

O

OE bit 10-11

off-chip (external) memory
 'C203 4-32
 'C204 4-35
 'C209 11-6

on-chip generators
 baud-rate generator 10-4
 clock generator 8-4
 'C209 clock options 11-14
 wait-state generator 8-14
 'C209 11-16

on-chip memory
 advantages 4-2
 flash, introduction 2-9

on-chip memory (*continued*)

RAM (dual-access)
available

'C203 4-32
 'C204 4-35
 'C209 11-6

configuration

'C203 4-33
 'C204 4-36
 'C209 11-8

description 2-7

RAM (single-access)

available, 'C209 11-6
configuration 11-7
description 2-8

ROM

available

'C204 4-35
 'C209 11-6

configuration

'C204 4-36
 'C209 11-7

introduction 2-8

on-chip peripherals

asynchronous serial port 10-1 to 10-20

available types 1-7

clock generator 8-4 to 8-6

'C209 clock options 11-14 to 11-18

control of 8-2 to 8-3

general-purpose I/O pins 8-17 to 8-20

overview 2-11

register locations and reset values 8-2

reset conditions 5-34, 8-2

synchronous serial port 9-1 to 9-30

timer 8-8 to 8-13

wait-state generator 8-14 to 8-16

'C209 11-16 to 11-18

on-chip registers mapped to data space

addresses and reset values A-2

quick reference figures A-4

on-chip registers mapped to I/O space

addresses and reset values A-2

quick reference figures A-4

on-chip ROM D-1

opcode format

direct addressing 6-5

immediate addressing 6-2

indirect addressing 6-12

OR instruction 7-129

oscillator 8-4

- OUT instruction 7-132
 - output modes
 - external count E-20
 - signal event E-20
 - output shifter 3-11
 - OV (overflow flag bit) 3-16
 - overflow in accumulator
 - detecting (OV bit) 3-16
 - enabling/disabling overflow mode (OVM bit) 3-17
 - overflow in synchronous serial port
 - burst mode 9-29
 - continuous mode 9-30
 - detecting (OVF bit) 9-10
 - overflow mode bit (OVM) 3-17
 - effects on accumulator 3-10
 - OVF bit 9-10
- P**
- PAB (program address bus)
 - definition 2-3
 - used in program-memory address generation 5-3
 - PAC instruction 7-134
 - packages, available types 1-7
 - pages of data memory, figure 6-4
 - PAL E-21, E-22, E-24
 - PAR (program address register)
 - definition F-16
 - shown in figure 5-2
 - parallel I/O ports 4-23
 - PC (program counter) 5-3
 - description 5-3
 - loading 5-4
 - shown in figure 5-2
 - peripherals (on-chip)
 - asynchronous serial port 10-1 to 10-20
 - available types 1-7
 - clock generator 8-4 to 8-6
 - 'C209 clock options 11-14 to 11-18
 - control of 8-2 to 8-3
 - general-purpose I/O pins 8-17 to 8-20
 - overview 2-11
 - register locations and reset values 8-2
 - reset conditions 5-34, 8-2
 - synchronous serial port 9-1 to 9-30
 - peripherals (on-chip) (*continued*)
 - timer 8-8 to 8-13
 - wait-state generator 8-14 to 8-16
 - 'C209 11-16 to 11-18
 - phase lock loop (PLL) 8-4
 - pins
 - asynchronous serial port 10-4
 - CLKOUT1 8-7
 - clock generator
 - CLKIN/X2 8-4
 - CLKMOD 11-14
 - DIV1 and DIV2 8-5
 - X1 8-4
 - general-purpose
 - BIO 8-17
 - IO0–IO3 10-15
 - XF 8-18
 - I/O and memory 4-3
 - IACK ('C209) 11-13
 - memory and I/O 4-3
 - READY 8-14
 - synchronous serial port 9-4
 - timer (TOUT) 8-8
 - wait-state (READY) 8-14
 - pipeline, operation 5-7
 - PM (product shift mode bits) 3-17
 - POP instruction 7-135
 - pop operation (diagram) 5-6
 - POPD instruction 7-137
 - power saving features 1-7
 - power-down mode 5-36
 - PRD F-23
 - PRD (timer period register) 8-12, F-23 to F-26
 - PRDB (program read bus) 2-3
 - PREG (product register) 3-6
 - PREG instructions
 - add PREG to accumulator (APAC) 7-37
 - add PREG to accumulator and load TREG (LTA) 7-93
 - add PREG to accumulator and multiply (MPYA) 7-116
 - add PREG to accumulator and square specified value (SQRA) 7-168
 - add PREG to accumulator, load TREG, and move data (LTD) 7-95
 - add PREG to accumulator, load TREG, and multiply (MAC) 7-102
 - add PREG to accumulator, load TREG, multiply, and move data (MACD) 7-106

- PREG instructions (*continued*)
 - load high bits of PREG (LPH) 7-85
 - set PREG output shift mode (SPM) 7-167
 - store high word of PREG to data memory (SPH) 7-161
 - store low word of PREG to data memory (SPL) 7-163
 - store PREG to accumulator (PAC instruction) 7-134
 - store PREG to accumulator and load TREG (LTP) 7-98
 - subtract PREG from accumulator (SPAC) 7-160
 - subtract PREG from accumulator and load TREG (LTS) 7-100
 - subtract PREG from accumulator and multiply (MPYS) 7-118
 - subtract PREG from accumulator and square specified value (SQRS) 7-170
- product register (PREG) 3-6
- product shift mode bits (PM) 3-17
- product shift modes 3-7
- product shifter 3-6
- program address bus (PAB)
 - definition 2-3
 - used in program-memory address generation 5-3
- program address register (PAR)
 - definition F-16
 - shown in figure 5-2
- program control features
 - See also* interrupts
 - address generation, program memory 5-2
 - branch instructions
 - conditional* 5-11
 - unconditional* 5-8
 - call instructions
 - conditional* 5-12
 - unconditional* 5-8
 - conditional instructions 5-10 to 5-13
 - conditions that may be tested* 5-10 to 5-13
 - stabilization of conditions* 5-11 to 5-13
 - using multiple conditions* 5-10
 - pipeline operation 5-7
 - program counter (PC) 5-3
 - loading* 5-4
 - program control features (*continued*)
 - repeating a single instruction 5-14
 - reset conditions 5-33
 - return instructions
 - conditional* 5-12
 - unconditional* 5-9
 - stack 5-4
 - status registers ST0 and ST1 3-15
 - bits* 3-15
- program counter (PC) 5-3
 - description 5-3
 - loading 5-4
 - shown in figure 5-2
- program examples C-1 to C-24
 - about the examples C-2
 - asynchronous serial port
 - automatic baud-rate detection test* C-16
 - delta interrupts* C-18
 - transmission* C-13
 - transmission loopback test* C-14
 - boot loader code
 - command file* C-24
 - hex conversion file* C-24
 - command file (generic) C-5
 - delay loops C-8
 - header file with I/O register declarations C-6
 - header file with interrupt vector declarations C-7
 - HOLD operation C-11
 - interrupt INT1 C-10
 - interrupts INT2 and INT3 C-12
 - synchronous serial port
 - transmission (continuous mode)* C-20
 - using with codec* C-21
 - timer C-9
- program memory
 - address generation logic 5-2
 - micro stack (MSTACK)* 5-6
 - program counter (PC)* 5-3
 - stack* 5-4
 - address map
 - 'C203 4-32
 - 'C204 4-35
 - 'C209 11-6
 - address sources 5-3

- program memory (*continued*)
 - configuration
 - RAM (*dual-access*)
 - 'C203 4-33
 - 'C204 4-36
 - 'C209 11-8
 - RAM (*single-access*) 11-7
 - ROM
 - 'C204 4-36
 - 'C209 11-7
 - description 4-5
 - external interfacing 4-5
 - caution about proper timing* 4-5
 - program memory select pin (\overline{PS})
 - definition 4-3
 - shown in figure 4-6
 - program read bus (PRDB) 2-3
 - program-address generation (diagram) 5-2
 - protocol, bus, in emulator system E-4
 - \overline{PS} (program memory select pin)
 - definition 4-3
 - shown in figure 4-6
 - PSC (timer prescaler counter)
 - 'C203/C204 8-11
 - 'C209 11-15
 - definition F-18
 - PSHD instruction 7-139
 - PSLWS bits 8-15
 - PSUWS bits 8-15
 - PSWS bit 11-17
 - PUSH instruction 7-141
 - push operation (diagram) 5-5
- R**
- R/\overline{W} (read/write pin) 4-4
 - RAM (on-chip)
 - dual-access
 - configuration*
 - 'C203 4-33
 - 'C204 4-36
 - 'C209 11-8
 - description* 2-7
 - single-access
 - configuration* 11-7
 - description* 2-8
 - RAMEN (single-access RAM enable pin)
 - definition 4-4
 - use in configuring memory 11-7
 - \overline{RD} (read select pin)
 - definition 4-4
 - shown in figure 4-6, 4-10, 4-13, 4-15
 - read select pin (\overline{RD})
 - definition 4-4
 - shown in figure 4-6, 4-10, 4-13, 4-15
 - read/write pin (R/\overline{W}) 4-4
 - READY (external device ready pin)
 - definition 4-4
 - generating wait states with 8-14
 - receive interrupt
 - asynchronous serial port 10-17
 - enabling/disabling (RIM bit)* 10-8
 - synchronous serial port 9-6
 - receive pin
 - asynchronous serial port (RX) 10-4
 - detecting break on (BI bit)* 10-10
 - synchronous serial port (DR) 9-4
 - receive register
 - asynchronous serial port (ADTR) 10-4
 - detecting overrun in (OE bit)* 10-11
 - detecting when empty (DR bit)* 10-11
 - synchronous serial port (SDTR) 9-5
 - receive shift register
 - asynchronous serial port (ARSR) 10-5
 - synchronous serial port (RSR) 9-5
 - register summary A-1 to A-14
 - registers
 - addresses and reset values A-2
 - asynchronous serial port
 - baud-rate divisor register (BRD)* 10-13
 - control register (ASPCR)* 10-7
 - I/O status register (IOSR)* 10-10
 - receive shift register (ARSR)* 10-5
 - transmit shift register (AXSR)* 10-5
 - auxiliary registers, current auxiliary register 6-13
 - auxiliary registers (AR0–AR7)
 - current auxiliary register* 6-9
 - next auxiliary register* 6-11
 - baud-rate divisor register (BRD) 10-13
 - CLKOUT1-pin control (CLK) register 8-7
 - I/O status register (IOSR) 10-10
 - interrupt control register (ICR) 5-24 to 5-38
 - interrupt flag register (IFR) 5-20 to 5-22
 - 'C209 11-12 to 11-18
 - interrupt mask register (IMR) 5-22 to 5-24
 - 'C209 11-13 to 11-18

- registers (*continued*)
 - mapped to data page 0 4-8
 - mapped to I/O space
 - 'C203/C204 4-24
 - 'C209 11-9
 - accessing 4-25
 - quick reference A-1 to A-14
 - status registers ST0 and ST1 3-15
 - timer
 - control register (TCR)
 - 'C203/C204 8-10
 - 'C209 11-16
 - counter register (TIM) 8-12, F-23
 - divide-down register (TDDR)
 - 'C203/C204 8-12
 - 'C209 11-16
 - period register (PRD) 8-12, F-23
 - prescaler counter (PSC)
 - 'C203/C204 8-11
 - 'C209 11-15
 - wait-state generator control register (WSGR)
 - 'C203/C204 8-15
 - 'C209 11-17
- repeat (RPT) instruction
 - description 7-146
 - introduction 5-14
- repeat counter (RPTC) 5-14
- repeating a single instruction 5-14
- reset 5-33
 - at same time as HOLD operation 4-29
 - effects 5-33
 - introduction 5-27
 - priority
 - 'C203/C204 5-16
 - 'C209 11-10
 - vector location
 - 'C203/C204 5-16
 - 'C209 11-10
- reset values of on-chip registers
 - mapped to data space 5-35, A-2
 - mapped to I/O space 5-35, A-2
 - status registers ST0 and ST1, A-2
- RET instruction 7-142
- RETC instruction 7-143
- return instructions
 - conditional, overview 5-12
 - return conditionally from subroutine (RETC) 7-143
 - return unconditionally from subroutine (RET) 7-142
 - unconditional, overview 5-9
- RFNE bit 9-9
- RIM bit 10-8
- RINT bit
 - in interrupt flag register (IFR) 5-22
 - in interrupt mask register (IMR) 5-23
- RINT interrupt
 - definition F-19
 - flag bit 5-22
 - mask bit 5-23
 - priority 5-16
 - vector location 5-16
- ROL instruction 7-144
- ROM, customized D-1 to D-3
- ROM (on-chip)
 - configuration
 - 'C204 4-36
 - 'C209 11-7
 - introduction 2-8
- ROM codes, submitting to Texas Instruments D-1 to D-3
- ROR instruction 7-145
- RPT instruction 7-146
- RPTC (repeat counter), 5-14
- $\overline{\text{RST}}$ bit 9-10
- $\overline{\text{RS}}$ (reset)
 - at same time as HOLD operation 4-29
 - effects 5-33
 - introduction 5-27
 - priority
 - 'C203/C204 5-16
 - 'C209 11-10
 - vector location
 - 'C203/C204 5-16
 - 'C209 11-10
- RSR (synchronous serial port receive shift register) 9-5
- run/stop operation E-10
- RUNB, debugger command E-20, E-21, E-22, E-23, E-24
- RUNB_ENABLE, input E-22
- RX pin 10-4

S

- SACH instruction 7-148
- SACL instruction 7-150
- SAR instruction 7-152
- SARAM (single-access RAM)
 - configuration 11-7
 - definition F-20
 - description 2-8
- SBRK instruction 7-154
- scaling shifters
 - input shifter 3-3
 - introduction 2-5
 - output shifter 3-11
 - product shifter 3-6
 - product shift modes* 3-7
- scan path linkers E-16
 - secondary JTAG scan chain to an SPL E-17
 - suggested timings E-22
 - usage E-16
- scan paths, TBC emulation connections for JTAG
 - scan paths E-25
- scanning logic overview 2-13
- SDTR (synchronous serial port transmit and receive register) 9-5
 - using to access FIFO buffers 9-15
- serial ports
 - See also* synchronous serial port; asynchronous serial port
 - available on TMS320C2xx devices 2-12
 - introduction 2-12
 - reset conditions 5-34
- serial-scan emulation capability 2-13
- SETBRK bit 10-8
- SETC instruction 7-155
- SFL instruction 7-157
- SFR instruction 7-158
- shifters
 - input shifter 3-3
 - introduction 2-5
 - output shifter 3-11
 - product shifter 3-6
 - product shift modes* 3-7
- short immediate addressing 6-2
- signal descriptions, 14-pin header E-3
- signals
 - buffered E-10
 - buffering for emulator connections E-10 to E-13
 - description, 14-pin header E-3
 - timing E-6
- sign-extension mode bit (SXM)
 - definition 3-17
 - effect on CALU (central arithmetic logic unit) 3-9
 - effect on input shifter 3-4
- single-access RAM (SARAM)
 - configuration 11-7
 - definition F-20
 - description 2-8
- single-access RAM enable pin (RAMEN)
 - definition 4-4
 - use in configuring memory 11-7
- slave devices E-4
- SOFT bit
 - asynchronous serial port 10-7
 - synchronous serial port 9-8
 - timer 8-11
- software interrupts
 - definition 5-15
 - instructions 5-27
- SPAC instruction 7-160
- SPH instruction 7-161
- SPL instruction 7-163
- SPLK instruction 7-165
- SPM instruction 7-167
- SQRA instruction 7-168
- SQRS instruction 7-170
- SSPCR (synchronous serial port control register) 9-8
 - quick reference A-12
- SST instruction 7-172
- ST0. *See* status registers ST0 and ST1
- ST1. *See* status registers ST0 and ST1
- stack 5-4
 - managing nested interrupt service routines 5-30
 - pop top of stack to data memory (POPD instruction) 7-137
 - pop top of stack to low accumulator bits (POP instruction) 7-135
 - push data memory value onto stack (PSHD instruction) 7-139
 - push low accumulator bits onto stack (PUSH instruction) 7-141

- status registers ST0 and ST1
 - addresses and reset values A-2
 - bits 3-15
 - clear control bit (CLRC instruction) 7-62
 - introduction 3-15
 - load (LST instruction) 7-87
 - load data page pointer (LDP instruction) 7-83
 - modify auxiliary register pointer (MAR instruction) 7-111
 - quick reference A-5
 - set control bit (SETC instruction) 7-155
 - set product shift mode (SPM instruction) 7-167
 - store (SST instruction) 7-172
- STB bit 10-8
- $\overline{\text{STRB}}$ (external access active strobe) 4-3
- SUB instruction 7-174
- SUBB instruction 7-178
- SUBC instruction 7-180
- SUBS instruction 7-182
- SUBT instruction 7-184
- subtract. *See* accumulator instructions
- SXM (sign-extension mode bit)
 - definition 3-17
 - effect on CALU (central arithmetic logic unit) 3-9
 - effect on input shifter 3-4
- synchronous serial port
 - See also* synchronous serial port registers
 - basic operation 9-6
 - bit input from CLKR pin (IN0 bit) 9-10
 - block diagram 9-3
 - burst mode (introduction) 9-12
 - CLKR pin as bit input (IN0 bit) 9-10
 - clock source for transmission (MCM bit) 9-12
 - components 9-3
 - configuration 9-8
 - continuous mode (introduction) 9-12
 - controlling and resetting 9-8
 - digital loopback mode 9-28
 - emulation modes 9-8, 9-28
 - error conditions
 - burst mode* 9-29
 - continuous mode* 9-29
 - features 9-1
 - synchronous serial port (*continued*)
 - FIFO buffers
 - detecting data in receive FIFO buffer (RFNE bit)* 9-9
 - detecting empty transmit FIFO buffer (TCOMP bit)* 9-9
 - introduction* 9-5
 - managing contents with SDTR* 9-15
 - frame sync modes (FSM bit) 9-12
 - frame sync source for transmission (TXM bit) 9-13
 - interrupts (XINT and RINT)
 - flag bits* 5-21
 - mask bits* 5-23
 - priorities* 5-16
 - receive (RINT)* 9-6
 - controlling (FR1 and FR0 bits) 9-10
 - transmit (XINT)* 9-6
 - controlling (FT1 and FT0 bits) 9-9
 - using* 9-13
 - vector locations* 5-16
 - introduction 2-12
 - overflow in receiver
 - burst mode* 9-29
 - continuous mode* 9-30
 - detecting (OVF bit)* 9-10
 - overview 9-2
 - pins 9-4
 - receiver operation 9-24
 - burst mode* 9-24
 - continuous mode* 9-25
 - registers (overview) 9-5
 - reset conditions 5-34
 - resetting 9-13
 - receiver (RRST bit)* 9-10
 - transmitter (XRST bit)* 9-10
 - selecting mode of operation 9-12
 - selecting transmit clock source 9-12
 - selecting transmit frame sync source 9-12
 - signals 9-3
 - testing 9-27
 - transmitter operation 9-16
 - burst mode with external frame sync* 9-18
 - burst mode with internal frame sync* 9-16
 - continuous mode with external frame sync* 9-22
 - continuous mode with internal frame sync* 9-20

synchronous serial port (*continued*)

troubleshooting

bits for testing the port 9-27

error conditions

burst mode 9-29

continuous mode 9-29

underflow in transmitter

burst mode 9-29

continuous mode 9-29

synchronous serial port registers

control register (SSPCR)

description 9-8

quick reference A-12

FIFO buffers

detecting data in receive FIFO buffer (RFNE bit) 9-9

detecting empty transmit FIFO buffer (TCOMP bit) 9-9

introduction 9-5

managing contents with SDTR 9-15

overview 9-5

receive shift register (RSR) 9-5

transmit and receive register (SDTR) 9-5

using to access FIFO buffers 9-15

transmit shift register (XSR) 9-5

T

target cable E-14

target system, connection to emulator E-1 to E-25

target system emulator connector, designing E-2

target-system clock E-12

TBLR instruction 7-186

TBLW instruction 7-189

TC (test/control flag bit) 3-17

response to accumulator event 3-10

response to auxiliary register compare 3-14

TCK signal E-2, E-3, E-4, E-6, E-7, E-13, E-17, E-18, E-25

TCOMP bit 9-9

TCR (timer control register) 8-10 to 8-12

'C209 11-15

quick reference A-9

TDDR (timer divide-down register)

'C203/C204 8-12

'C209 11-16

definition F-23

TDI signal E-2, E-3, E-4, E-5, E-6, E-7, E-8, E-13, E-18

TDO signal E-4, E-5, E-8, E-19, E-25

temporary register (TREG) 3-6

TEMT bit 10-10

test bus controller E-22, E-24

test clock E-12

diagram E-12

test/control flag bit (TC) 3-17

response to accumulator event 3-10

response to auxiliary register compare 3-14

THRE bit 10-11

TIM (timer counter register) 8-12, F-23 to F-26

TIM bit 10-8

timer 8-8 to 8-13

block diagram 8-8

control register (TCR) 8-10 to 8-12

counter register (TIM) 8-12, F-23 to F-26

divide-down register (TDDR)

'C203/C204 8-12

'C209 11-16

definition F-23

emulation modes (FREE and SOFT bits) 8-11

interrupt (TINT)

'C203/C204

flag bit 5-22

mask bit 5-23

priority 5-16

vector location 5-16

'C209

flag bit 11-12

mask bit 11-13

priority 11-10

vector location 11-10

interrupt rate 8-13

operation 8-9 to 8-10

period register (PRD) 8-12, F-23 to F-26

prescaler counter (PSC)

'C203/C204 8-11

'C209 11-15

reload

'C203/C204 8-11

'C209 11-15

reset 8-13

setting interrupt rate 8-13

stop/start

'C203/C204 8-12

'C209 11-16

- timer control register (TCR) 8-10 to 8-12
 - 'C209 11-15
 - quick reference A-9
- timer counter register (TIM) 8-12, F-23 to F-26
- timer period register (PRD) 8-12, F-23 to F-26
- timing calculations E-7 to E-9, E-18 to E-26
- TINT bit
 - 'C203/C204
 - in interrupt flag register (IFR)* 5-22
 - in interrupt mask register (IMR)* 5-23
 - 'C209
 - in interrupt flag register (IFR)* 11-12
 - in interrupt mask register (IMR)* 11-13
- TINT interrupt
 - 'C203/C204
 - flag bit* 5-22
 - mask bit* 5-23
 - priority* 5-16
 - vector location* 5-16
 - 'C209
 - flag bit* 11-12
 - mask bit* 11-13
 - priority* 11-10
 - vector location* 11-10
 - definition F-23
- TMS signal E-2, E-3, E-4, E-5, E-6, E-7, E-8, E-13, E-17, E-18, E-19, E-25
- TMS/TDI inputs E-4
- TMS320 devices
 - applications 1-4
 - evolution (figure) 1-3
 - overview 1-2
- TMS320 ROM code submittal, flow chart D-2
- TMS320C1x/C2x/C2xx/C5x instruction set comparisons B-1 to B-36
- TMS320C209 device 11-1 to 11-18
 - comparison to other 'C2xx devices 11-2
 - differences in interrupts* 11-3
 - differences in memory and I/O spaces* 11-3
 - differences in peripherals* 11-2
 - similarities* 11-2
 - interrupts 11-10
 - locating 'C209 information in this manual (table) 11-3
 - memory and I/O spaces 11-5
 - on-chip peripherals 11-14
- transmit interrupt
 - asynchronous serial port 10-17
 - enabling/disabling (TIM bit)* 10-8
 - synchronous serial port 9-6
- transmit pin
 - asynchronous serial port (TX) 10-4
 - output level between transmissions (SETBRK bit)* 10-8
 - synchronous serial port (DX) 9-4
- transmit register
 - asynchronous serial port (ADTR) 10-4
 - detecting when empty (THRE bit)* 10-11
 - detecting when it and AXSR are empty (TEMT bit)* 10-10
 - synchronous serial port (SDTR) 9-5
- transmit shift register
 - asynchronous serial port (AXSR) 10-5
 - detecting when it and ADTR are empty (TEMT bit)* 10-10
 - synchronous serial port (XSR) 9-5
- TRAP instruction 7-192
 - introduction 5-28
 - vector location
 - 'C203/C204 5-17
 - 'C209 11-11
- TRB bit
 - 'C203/C204 8-11
 - 'C209 11-15
- TREG (temporary register) 3-6
- TREG instructions
 - load accumulator using shift specified by TREG (LACT) 7-78
 - load TREG (LT) 7-91
 - load TREG and add PREG to accumulator (LTA) 7-93
 - load TREG and store PREG to accumulator (LTP) 7-98
 - load TREG and subtract PREG from accumulator (LTS) 7-100
 - load TREG, add PREG to accumulator, and move data (LTD) 7-95
 - load TREG, add PREG to accumulator, and multiply (MAC) 7-102
 - load TREG, add PREG to accumulator, multiply, and move data (MACD) 7-106
- TRST signal E-2, E-3, E-6, E-7, E-13, E-17, E-18, E-25

TSS bit
 'C203/C204 8-12
 'C209 11-16

TX pin 10-4

TXM bit 9-11

TXRXINT bit
 in interrupt flag register (IFR) 5-21
 in interrupt mask register (IMR) 5-23

TXRXINT interrupt
 flag bit 5-21
 mask bit in IMR 5-23
 priority 5-16
 vector location 5-16

U

unconditional instructions
 unconditional branch 5-8
 unconditional call 5-8
 unconditional return 5-9

underflow in synchronous serial port
 burst mode 9-29
 continuous mode 9-29

URST bit 10-7

W

wait states
 definition F-25
 for data space
 'C203/C204 8-15
 'C209 11-17
 for I/O space
 'C203/C204 8-15
 'C209 11-17
 for program space
 'C203/C204 8-15
 'C209 11-17
 generating with READY signal 8-14

wait states (*continued*)
 generating with wait-state generator
 'C203/C204 8-14 to 8-17
 'C209 11-16 to 11-18

wait-state generator 8-14 to 8-16
 'C209 11-16 to 11-18
 introduction 2-11

wait-state generator control register (WSGR) 8-15
 'C209 11-17
 quick reference A-10

\overline{WE} (write enable pin)
 definition 4-4
 shown in figure 4-6, 4-10, 4-13, 4-26

write enable pin (\overline{WE})
 definition 4-4
 shown in figure 4-6, 4-10, 4-13, 4-26

WSGR (wait-state generator control register)
 'C203/C204 8-15
 'C209 11-17
 quick reference A-10

X

XDS510 emulator. *See* emulation; emulator

XF bit (XF pin status bit) 3-17

XF pin 8-18

XINT bit
 in interrupt flag register (IFR) 5-21
 in interrupt mask register (IMR) 5-23

XINT interrupt
 flag bit 5-21
 mask bit 5-23
 priority 5-16
 vector location 5-16

XOR instruction 7-193

XRST bit 9-10

XSR (synchronous serial port transmit shift register) 9-5

Z

ZALR instruction 7-196

Free Manuals Download Website

<http://myh66.com>

<http://usermanuals.us>

<http://www.somanuals.com>

<http://www.4manuals.cc>

<http://www.manual-lib.com>

<http://www.404manual.com>

<http://www.luxmanual.com>

<http://aubethermostatmanual.com>

Golf course search by state

<http://golfingnear.com>

Email search by domain

<http://emailbydomain.com>

Auto manuals search

<http://auto.somanuals.com>

TV manuals search

<http://tv.somanuals.com>