

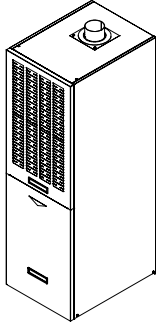

GAS-FIRED OR OIL-FIRED FURNACE DOWN FLOW & DIRECT VENT (SEALED COMBUSTION)



MODELS: OMC-70 AND GMC-85 INSTALLATION AND SERVICE MANUAL

For installation in:

1. Manufactured Homes
2. Modular Homes/Buildings
3. Site Construction—Residential (Single Story Dwellings)

⚠WARNING:

FOR YOUR SAFETY

Do not store or use gasoline or other flammable vapors and liquids in the vicinity of this or any other appliance.

WHAT TO DO IF YOU SMELL GAS

- Do not try to light any appliance.
- Do not touch any electrical switch; do not use any phone in your building.
- Immediately call your gas supplier from a neighbor's phone.
Follow the gas supplier's instructions.
- If you cannot reach your gas supplier, call the fire department.

⚠WARNING: *If the information in these instructions is not followed exactly, a fire or explosion may result causing property damage, personal injury or loss of life.*

⚠WARNING: *Improper installation, adjustment, alteration, service, or maintenance can cause injury or property damage. Refer to this manual. For assistance or additional information consult a qualified installer, service agency, or fuel supplier.*

⚠WARNING: *Do not use this appliance if any part has been underwater. Immediately call a qualified service technician to inspect the appliance and to replace any part of the electrical or control system that has been underwater.*

PLEASE READ THESE INSTRUCTIONS PRIOR TO INSTALLATION, INITIAL FIRING, AND BEFORE PERFORMING ANY SERVICE OR MAINTENANCE. THESE INSTRUCTIONS MUST BE LEFT WITH THE USER AND SHOULD BE RETAINED FOR FUTURE REFERENCE BY QUALIFIED SERVICE PERSONNEL.



THERMO PRODUCTS, LLC.
POST OFFICE BOX 217
NORTH JUDSON, IN 46366
PHONE: (574) 896-2133



MO-422
ECN 4528-MA

MADE IN USA

All installations and services must be performed by qualified service personnel.

I. SAFETY SECTION

This page and the following two pages contain various warnings and cautions found throughout this furnace Service and Installation Manual. Please read and comply with the statements on the cover and the statements below.

⚠WARNING: *All local codes and ordinances must be followed with regard to the oil tank and oil lines. All lines must have shut off valves, use a proper pipe joint compound (specified for use with oil) on all pipe threads, no kinks, no sharp bends, and be properly tested for leaks. Flare fittings are recommended for tubing.*

⚠WARNING: *This furnace is not to be used as a construction heater.*

⚠WARNING: *DO NOT RUN THE OIL PUMP DRY FOR MORE THAN FIVE MINUTES.*

⚠WARNING: *When testing electrical equipment, always follow standard electrical procedures and precautions.*

⚠WARNING: *The heat exchanger must be cleaned by a qualified service person.*

⚠WARNING: *The area around the furnace should be kept free and clear of combustible materials, especially papers and rags.*

⚠WARNING: *NEVER burn garbage or refuse in your furnace. NEVER try to ignite oil or gas by tossing burning papers or other material into your furnace.*

⚠WARNING: *Thermo Pride oil furnaces are designed to burn commercial standards of No. 1 and No. 2 fuel oil. NEVER USE GASOLINE OR A MIXTURE OF OIL AND GASOLINE.*

⚠WARNING: *Do not attempt to start the burner when: 1. Excess oil has accumulated 2. The furnace is full of vapors or 3. The combustion chamber is very hot. If one or more of these conditions exist, contact a qualified service person.*

⚠CAUTION: *If the temperature rise exceeds 100°F, the heat exchanger may fail voiding the heat exchanger warranty resulting in property damage, personal injury or loss of life.*

⚠WARNING: *Burner adjustments must be confirmed by instrumentation. Failure to use accurate or calibrated instrumentation to setup the burner may result in reduced efficiency, sooting and/or the production of hazardous carbon monoxide gas.*

⚠WARNING: *Any attempt to relocate safety controls or replace safety controls with a control that is not approved or incompatible, may result in personal injury, substantial property damage or death.*

All installations and services must be performed by qualified service personnel.

⚠WARNING: *If you do not follow these instructions exactly, a fire or explosion may result causing personal injury, loss of life or property damage.*

⚠WARNING: *NEVER use gasoline or a mixture of oil and gasoline to start the burner or furnace.*

⚠WARNING: HAZARD OF ASPHYXIATION: *Negative pressure inside the closet with closet door closed and the furnace blower operating shall be no more negative than minus 0.05 inch water column.*

⚠WARNING: *Do not obstruct any return air openings, including the return grille on the furnace. To do so may cause the furnace to activate the high limit and shut down or it may cause asphyxiation.*

⚠WARNING: *Because of the potential of odorant fade, a gas leak may not be detected by smell. If this furnace is installed below grade, contact your gas supplier for a gas detector.*

⚠WARNING: *All gas pipe connections must be leak tested using a strong soap and water solution (with the gas turned on). Any leaks must be repaired immediately after turning off the gas supply. A final test for gas leakage must be made after purging the gas line.*

⚠CAUTION: *DO NOT wet electronic components during the leak test. Wetting electronic components may damage circuitry and cause a hazardous situation. Dry moisture from all leads and terminals if wetting occurs. Wait at least 24 hours for the circuit to fully dry before energizing the system.*

⚠WARNING: *The furnace and its gas valve must be disconnected from the gas supply during pressure testing of the gas supply system at pressures in excess of 1/2 PSIG or 13.9 inches W.G. The furnace can be isolated from the gas supply by closing its manual shut off valve at test pressures equal to or less than 1/2 PSIG or 13.9 inches W.G.*

⚠WARNING: *Copper and brass tubing and fittings (except tin lined) shall not be used if the gas contains more than a trace (0.3 grains per 100 cubic ft.) of hydrogen sulfide gas. Check with your gas supplier.*

⚠WARNING: *All local codes and ordinances take precedence with regard to tank and oil lines. All lines must have shutoff valves, a good pipe joint compound approved for use with oil on all pipe threads, no kinks, no sharp bends and be properly tested for leaks. Flare fittings are recommended for tubing.*

⚠CAUTION: *Do not use motor oil or any fuel other than No. 1 or No. 2 fuel oil in this furnace.*

All installations and services must be performed by qualified service personnel.

⚠WARNING: *If you suspect there is a problem with the furnace, the venting system or any other related problem, immediately contact a qualified service agency. If a service agency is not available contact your fuel supplier.*

⚠WARNING: *Personal injury, or property damage, could result from major repair or service of this furnace by anyone other than a qualified contractor. Only the routine maintenance described in the user section of this manual should be performed by the user.*

⚠WARNING: *The area around the furnace should be kept free and clear of combustible materials, especially papers and rags.*

⚠WARNING: *Never burn garbage or refuse in your furnace. Never try to ignite oil or gas by tossing burning papers or other material into your furnace.*

⚠CAUTION: *Do not attempt to start the burner when:*

- 1. Excess oil or gas has accumulated.*
- 2. The furnace is full of vapors.*
- 4. The combustion chamber is very hot.*

If one or more of these conditions exist, contact a qualified service person.

⚠CAUTION: *Do not block or obstruct air openings on the furnace or air openings communicating with the area in which the furnace is installed.*

⚠CAUTION: *Do not allow the outside air intake to be blocked or obstructed by vegetation, ice, snow or any other materials.*

⚠WARNING: *Do not use this furnace if any part has been underwater. Immediately call a qualified service agency to inspect the furnace and to replace any part of the electrical or control system which has been underwater.*

⚠WARNING: *Should overheating occur or the fuel supply fail to shut off, shut off the manual fuel supply valve to the furnace before shutting off the electrical supply.*

All installations and services must be performed by qualified service personnel.

This page and the following page contain reproductions of the various warning and instruction labels placed on the Thermo Pride Oil Furnace. Please read and comply with the contents of these labels.

SHOULD THIS UNIT BE DISASSEMBLED ALL COMPONENTS, PANELS, BLOCK OFFS, COLLARS, GASKETS, AND FASTENERS MUST BE REASSEMBLED AS ORIGINALLY FACTORY PRODUCED.

390056

FOR LIGHTING, OPERATING AND SHUTDOWN INSTRUCTIONS, REFER TO THE MOBILE HOME FURNACE MANUAL.

NATURAL/PROPANE GAS CONVERSION INSTRUCTIONS

An alternate main burner orifice and a gas valve pressure regulator conversion kit are supplied with the furnace.

1. Shut off electric power at the furnace and close the manual gas shutoff valve serving the furnace.
2. Disconnect the gas supply pipe below the gas control valve.
3. Remove two (2) hex nuts from orifice holder studs. Pull out holder and change main burner orifice. Reassemble holder plate to the burner. Reconnect the gas supply line.
4. Remove the capscrew from gas valve pressure regulator.
5. Turn the plastic regulator screw counter clockwise to remove it.
6. Remove the regulator spring and replace it with the spring found in the pressure regulator conversion kit. (Refer to any instructions supplied in the kit.)
7. Replace the plastic regulator screw and turn the screw clockwise about six (6) complete turns.
8. Open the manual gas shutoff valve and turn the power switch on.
9. During burner operation, turn the regulator screw to set the required burner manifold pressure, refer to the table below.
10. Replace the gas valve pressure regulator capscrew.

Fuel Type	Main Orifice (DMS No.)	Manifold Pressure (in. W.G.)
Natural gas	17	3.5
Propane gas	36	10

390454

WARNING

ALL COMBUSTION AIR OR MANIFOLD PRESSURE ADJUSTMENTS MUST BE MADE BY A QUALIFIED SERVICE PERSON.

IMPROPER ADJUSTMENT CAN CREATE HAZARDOUS FLUE GAS WHICH CAN CAUSE PERSONAL INJURY OR LOSS OF LIFE.

390315

WARNING – TO REDUCE THE RISK OF FIRE, DO NOT STORE OR USE GASOLINE OR OTHER FLAMMABLE VAPORS AND LIQUIDS IN THE VICINITY OF THE FURNACE.

390448

CAUTION SHOULD BE USED IN CLEANING AND SERVICING FURNACE TO AVOID DAMAGING COMBUSTION CHAMBER LINER.

390450

All installations and services must be performed by qualified service personnel.

WARNING

SPECIAL HOMEOWNERS INSTRUCTIONS

- **IMPROPER INSTALLATION, ADJUSTMENT, ALTERATION, SERVICE OR MAINTENANCE CAN CAUSE PROPERTY DAMAGE, PERSONAL INJURY OR LOSS OF LIFE.**
- **FOR SAFE OPERATION** IT IS THE RESPONSIBILITY OF THE OWNER AND/OR USER THAT THE BURNER, CHIMNEY/VENT PIPE, HEAT EXCHANGER AND CONTROLS SHOULD BE INSPECTED EVERY YEAR BY A QUALIFIED HEATING CONTRACTOR.
- THE OWNER AND/OR USER SHOULD ALSO CONDUCT PERIODIC VISUAL INSPECTIONS. REFER TO THE USERS INFORMATION SECTION IN THE MANUAL PROVIDED WITH THIS FURNACE FOR DETAILS.
- ANY DEFICIENCIES NOTED MUST BE CORRECTED AT ONCE BY A QUALIFIED HEATING CONTRACTOR. DO NOT ATTEMPT TO MAKE REPAIRS YOURSELF!
- FOR ASSISTANCE OR ADDITIONAL INFORMATION CONSULT A QUALIFIED INSTALLER, SERVICE AGENCY OR THE GAS/OIL SUPPLIER.

CAUTION

**MOVING PARTS.
CAN CAUSE SEVERE PERSONAL INJURY**

SHUT OFF FURNACE BEFORE
REMOVING THIS PANEL.

FOR YOUR SAFETY

**DO NOT STORE GASOLINE OR OTHER
FLAMMABLE VAPORS AND LIQUIDS IN
THE VICINITY OF THIS OR ANY OTHER
APPLIANCE.**

**THIS UNIT MUST BE INSTALLED AND
SERVICED BY A QUALIFIED
CONTRACTOR ONLY.**

FILTER MAINTENANCE: WHEN IT BECOMES
NECESSARY TO REPLACE OR WASH
FILTER REMOVE THE DIRTY FILTER FROM
THE RACKS PROVIDED AND WASH OR
REPLACE WITH IDENTICAL NEW FILTERS.

DO NOT REMOVE THIS LABEL

390437

KEEP CLOSED WHEN
APPLIANCE IN OPERATION

390400

**"DANGER— TO AVOID INJURY FROM MOVING
PARTS SHUT OFF THE FURNACE BEFORE
REMOVING THIS DOOR."**

WHEN IT BECOMES NECESSARY TO REPLACE OR WASH
FILTER, REMOVE THE DIRTY FILTER FROM THE RACKS
PROVIDED AND WASH OR REPLACE WITH IDENTICAL NEW
FILTERS.

THE BLOWER MOTOR LOCATED BEHIND THIS DOOR MAY
OR MAY NOT REQUIRE LUBRICATION. IF LUBRICATION
INSTRUCTIONS ARE NOT SHOWN ON THE MOTOR NAME
PLATE THE MOTOR SHOULD NOT BE LUBRICATED. IF
THE NAME PLATE INDICATES THAT THE MOTOR REQUIRES
LUBRICATION, LUBRICATE THE MOTOR AS DIRECTED OR USE
30 DROPS OF SAE 20 WEIGHT OIL OR EQUIVALENT
TWICE A YEAR. DO NOT USE A LIGHT HOUSEHOLD
GRADE OIL.

390025

POWER SWITCH

LO-230

All installations and services must be performed by qualified service personnel.

TABLE OF CONTENTS

<u>SECTION</u>	<u>BEGINNING PAGE</u>
I. SAFETY SECTION	1
II. GENERAL INSTRUCTIONS AND CLEARANCES	7
III. FURNACE SPECIFICATIONS	9
IV. INSTALLATION	11
A. ROOF JACK	11
B. STANDARD CHIMNEY	11
C. FURNACE LOCATION	11
D. BASE INSTALLATION	13
1. Combustible Floor Base Model: 70-BASE	13
2. Cottage Base Model: OMCCOT-BASE	14
E. ALCOVE INSTALLATION	16
F. CLOSET INSTALLATION	16
G. COMBUSTION AIR	17
H. FUEL PIPING	20
1. General Gas Piping	20
2. Oil Tank and Piping	21
J. ELECTRICAL WIRING	23
1. Electrical Branch Supply Circuit	24
2. Connection of Power Supply Wires	24
3. Connection of Thermostat Wires	24
4. Wiring Diagram	26
K. BURNER INSTALLATION	27
L. BURNER OPERATION AND ADJUSTMENT	28
M. FLUE GAS COMBUSTION ANALYSIS	30
V. DEALER MAINTENANCE	31
A. TROUBLESHOOTING	31
B. CAD CELL CHECKOUT PROCEDURE	37
C. HEAT EXCHANGER CLEANING INSTRUCTIONS	38
D. CLEANING OR REPLACING FLUE PIPES	39
E. EXTENDED SHUTDOWN AND RESTART	40
VI. USERS INFORMATION SECTION	41
A. WARNINGS & CAUTIONS	41
B. COMPONENT LOCATIONS	42
C. INSPECTION AREAS	42
D. FILTER LOCATION AND CLEANING	43
APPENDIX A - REPLACEMENT PARTS LIST	44

All installations and services must be performed by qualified service personnel.

II. GENERAL INSTRUCTIONS AND CLEARANCES

NOTE: READ THIS SECTION BEFORE STARTING INSTALLATION

1. The selection of a furnace heating capacity for a proposed installation should be based on a heat loss calculation made according to the manuals provided by the Air Conditioning Contractors of America (ACCA) or the American Society of Heating, Refrigeration and Air Conditioning Engineers, Inc. (ASHRAE).
2. The installer shall be familiar with and comply with all codes and regulations applicable to the installation of these heating appliances and related equipment. In lieu of local codes, the installation shall be in accordance with the current provisions of one or more of the following standards.
 - a. Federal Manufactured Home Constructions & Safety Standard (HUD Total 24, Part 280).
 - b. American National Standard (ANSI-119.2/NFPA-501C), for all recreational vehicle installations.
 - c. American National Standard (ANSI-Z223.1/NFPA-54), for all gas-fired furnaces.
 - d. American National Standard (ANSI-Z95.1/NFPA-31), for all oil-fired furnaces.
 - e. American National Standard Electric Code (ANSI-C1/NFPA-70), for all electrical field wiring.

The oil-fired furnace has been investigated under the UL 307A test standard and the gas-fired furnace under the UL 307B test standard. Both gas and oil fired units are listed by Underwriters Laboratories and described as, "For installation as central furnace special type for single story dwelling."

⚠WARNING: The area around the furnace must be kept free and clear of combustible materials, especially papers and rags.

⚠WARNING: This furnace is not to be used as a construction heater.

1. Definitions of "combustible" and "non-combustible" materials as presented in the 1996 version of the National Fuel Gas Code, ANSI Z223.1-1996/NFPA 70-1996, are as follows:
 - a. **Combustible material:**
"...materials made of or surfaced with wood, compressed paper, plant fibers, or other materials that are capable of being ignited and burned. Such materials shall be considered combustible even though flameproofed, fire-retardant treated, or plastered."

All installations and services must be performed by qualified service personnel.

b. Non-combustible material:

“...material that is not capable of being ignited and burned; such as material consisting entirely of, or a combination of, steel, iron, brick, concrete, slate, asbestos, glass, and plaster.”

This heating appliance must be installed with clearances to combustible material surfaces of not less than the minimum distances given below. Also, allow ample clearances for servicing the furnace for easy access to the air filter, blower assembly, burner assembly, controls, and vent connections.

MODELS OMC/GMC	CLOSET	ALCOVE
FRONT	6”	18”
BACK	0”	0”
SIDES	0”	0”
ROOF JACK	0”	0”
VENT CONNECTOR	6”	6”
TOP	1”	1”
PLENUM SIDES	1”	1”
TOP AND SIDES OF DUCT	1”	1”
BOTTOM OF DUCT	1”	1”

All installations and services must be performed by qualified service personnel.

III. FURNACE SPECIFICATIONS

<u>MODEL</u>	<u>OMC-70</u>	<u>GMC-85</u>
HEAT INPUT RATE (BTUH)	85,000	85,000
HEATING CAPACITY (BTUH)	71,000	69,700
BURNER NOZZLE (GPH X ANGLE, HOLLOW CONE)	0.65X80A	-----
BURNER ORIFICE-NAT. GAS	-----	#17 DMS
BURNER ORIFICE-PROP. GAS	-----	#36 DMS
OIL PUMP PRESSURE (PSIG)	100	-----
GAS SUPPLY PRESSURE (IN.W.G.) MINIMUM REQUIRED		
PROPANE	-----	11
NATURAL	-----	4.5
MAXIMUM ALLOWED		
PROPANE	-----	13.9
NATURAL	-----	13.9
GAS MANIFOLD PRESSURE (IN. W.G.)		
PROPANE	-----	10 ± 0.3
NATURAL	-----	3.5 ± 0.3
VENT PIPE SIZE (INCHES)	4	4
DESIGN TEMPERATURE RISE (°F)	85	85
SEASONAL EFFICIENCY (AFUE*, %)	84	82

*AFUE - INCLUDES STEADY STATE THERMAL EFFICIENCY AND OFF CYCLE LOSSES.

ELECTRICAL RATINGS AND SETTINGS:

ELECTRICAL SUPPLY: 120 VAC / 60HZ / 1 PHASE

MAXIMUM TIME DELAY TYPE FUSE OR HACR BREAKER RATING: 15 AMPS

TOTAL RATED CURRENT (AMPS): 11.3 (OMC), 6.81 (GMC)

NOMINAL HEAT ANTICIPATOR SETTING -- 0.2 mA (OMC), 0.8 mA (GMC)

DIMENSIONS & WEIGHTS:

CABINET: WIDTH - 18 IN., DEPTH - 24 IN., HEIGHT - 57 IN.

NO.70 MOBILE HOME BASE: WIDTH - 18 5/16 IN., DEPTH - 24¼ IN., HEIGHT - 4 IN.

WARM AIR DUCT: WIDTH - 12 IN., DEPTH - 12 IN., HEIGHT - 14 ¼ IN.

COTTAGE BASE: WIDTH - 18 3/16 IN., DEPTH - 24¼ IN., HEIGHT - 14¾ IN.

FILTER QUANTITY & SIZE: (2) @ 17 ¾ IN. x 13 ¾ IN. x 1 IN. EA.

APPROXIMATE SHIPPING WEIGHT: 240 LBS.

PRODUCT LISTED UNDER UL FILE NUMBER -- MP3241

All installations and services must be performed by qualified service personnel.

BURNER DATA

OMC-70

GMC-85

MANUFACTURER:	R.W. BECKETT CORP.	WAYNE COMBUSTION SYSTEMS
MODEL:	AFG	P265 FEP
AIR TUBE LENGTH (IN.):	3-5/8	3-5/8
HEAD DESIGN:	F-3	-----
REFRACTORY TYPE:	MHC (FIBER)	MHC (FIBER)
OIL PUMP PRESSURE (P.S.I.G.)	100	-----

FOR BURNER COMBUSTION INFORMATION, REFER TO SECTION (M) – FLUE GAS COMBUSTION ANALYSIS.

BLOWER DATA

MANUFACTURER: MORRISON PRODUCTS, INC.
BLOWER MODEL: 10-7, DIRECT DRIVE
NOMINAL MOTOR POWER OUTPUT (HORSEPOWER): 1/5
NOMINAL MOTOR SHAFT SPEED (RPM): 1075

TYPICAL AIRFLOW ON LOW FAN SPEED

@ SPECIFIED EXTERNAL

STATIC PRESSURES (SCFM @ .IN.W.G.): 780 @ 0.2, 650 @ 0.5

ALL SPECIFICATIONS ARE SUBJECT TO CHANGE WITHOUT NOTICE.

All installations and services must be performed by qualified service personnel.

IV. INSTALLATION

A. ROOF JACK

The roof jack assembly and accessories must be listed by a nationally recognized testing agency for the appropriate fuel.

The roof jack assembly must be installed according to the vent manufacturer's instructions prior to the furnace installation. (Refer to Figure 2 for flue location on furnace.) Adapters for pitched roofs as well as extended barrel length roof jacks are available from other suppliers.

All vent seams and connections must be sealed with high temperature silicone caulk and/or high temperature aluminum tape.

B. STANDARD CHIMNEY

When installed as a central furnace special type for single story dwelling, venting into a metal vent system approved by a nationally recognized testing agency for the appropriate fuel type is permitted. Lined masonry chimneys are acceptable when sized appropriately. The minimum chimney size should be equivalent to the inside free area of the 4-inch diameter vent collar exiting the furnace, or 12.5 square inches.

Maximum chimney sizes and acceptable installation practices are referenced in the following publications. In lieu of local codes, when installing the OMC-70 with fuel oil, refer to the latest edition of the installation standard NFPA 31, Installation of Oil Burning Equipment. When installing the GMC-85 with natural or LP gases, refer to Appendix G of the latest edition of the installation standard NFPA 54, National Fuel Gas Code.

C. FURNACE LOCATION

1. For best performance, locate the furnace so that it is centralized with respect to the duct system.
2. This furnace is only intended for installation with free air return through the furnace door louvers. **DO NOT** connect a ducted return air system directly to the furnace. Improper installation may create a fire hazard and damage internal equipment, as well as void all manufacturer's warranties.
3. This furnace may be installed on combustible flooring when utilizing either the No. 70 counterflow floor base, for below the floor duct systems, or with the cottage base, for floor level air distribution. See Figures 1 for depictions of the No. 70 and the cottage bases.
4. This furnace is U.L. listed for closet, alcove or freestanding applications. All applications must comply with the requirements of this manual.

All installations and services must be performed by qualified service personnel.

**Combustible Floor Base
Model: 70-BASE**

Figure 1A.

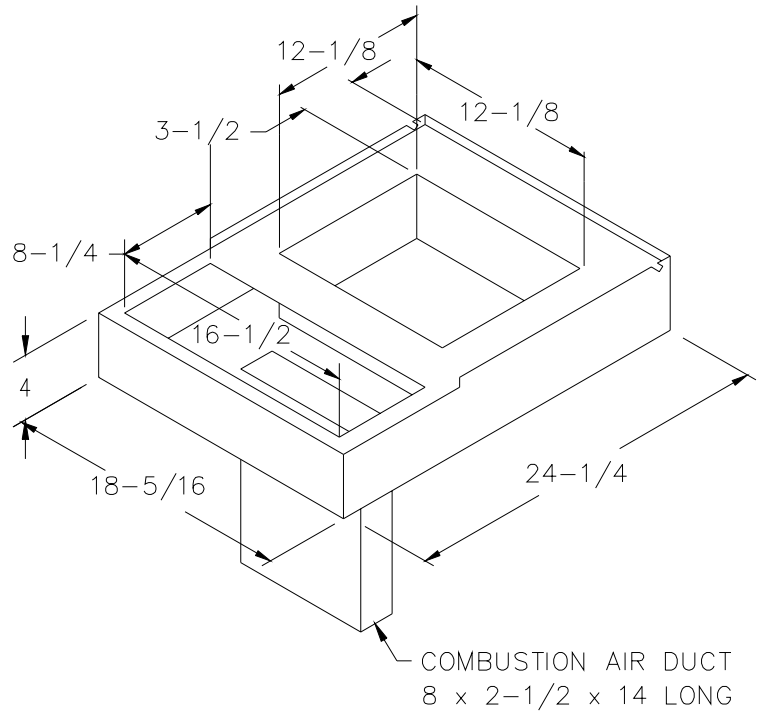

**Cottage Base
Model: 01COT-BASE**

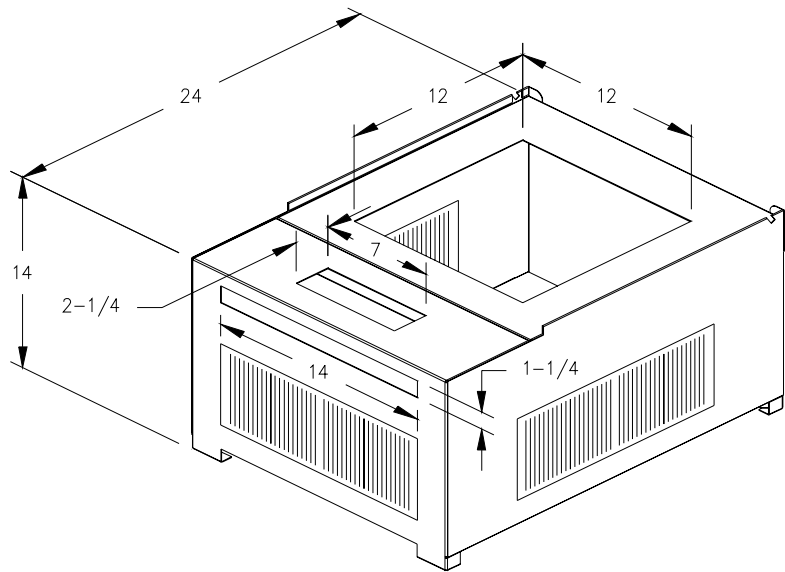

All installations and services must be performed by qualified service personnel.

Figure 1B.

D. BASE INSTALLATION

1. Combustible Floor Base Model: 70-BASE

Referring to Figure 1A, for applications using a combustion air channel and a supply air duct, use the base as a template to mark the floor opening locations. See Figure 2 for cutout locations. Cut a square opening in the floor for the supply air duct. Cut the opening 1-inch larger than the square template opening. Cut the combustion air duct opening. Cut opening 1/8 inch larger than the template opening. See Figure 1A for cutout sizes.

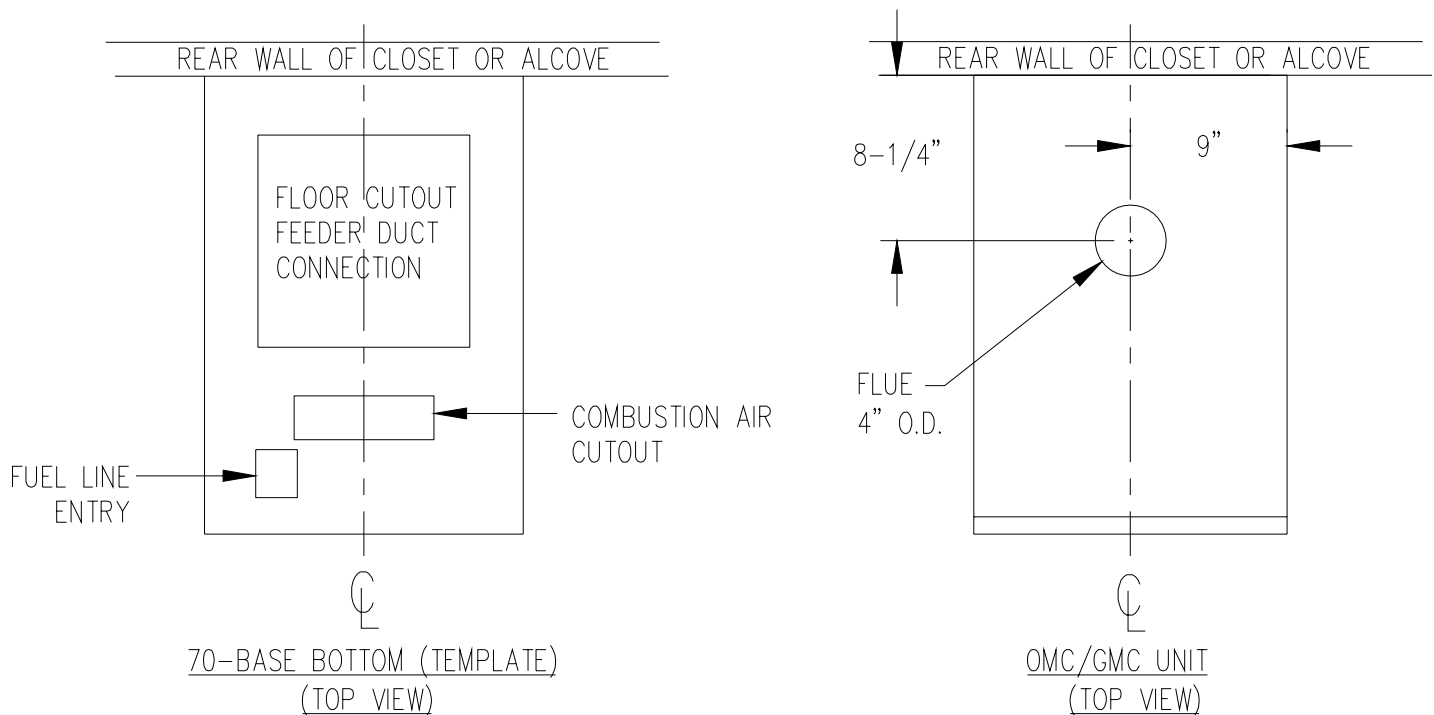

Figure 2.

Place the bottom base panel in position. Mark the square opening location on the distribution duct at the connection point of feeder duct. Remove the bottom panel. Cut an opening in the duct slightly larger than the feeder duct. Cut the feeder duct to length. (Refer to Figure 3 for location of this cut.) Install the feeder duct. Bend over each tab. Insure an airtight seal by using high temperature sealant or tape on the joint. Reinstall the bottom panel over the feeder duct. Insert and secure the combustion air duct. Put the top panel in place.

IMPORTANT: *A combustion air duct must be used. If the underside of the mobile home is skirted or enclosed (e.g. enclosed in a crawlspace), the combustion air intake should exit through the skirting, or enclosure, if at all possible. All joints and seams of supply ducts and combustion air ducts must be closed with a sealing method suitable to the application conditions and temperatures (e.g. high temperature silicone caulk and/or aluminum tape).*

All installations and services must be performed by qualified service personnel.

If the combustion air passageway cannot terminate outside of the skirting or enclosure, a permanent opening with a minimum of 50 square inches of unobstructed infiltration (free area) for ventilation air must be provided for adequate combustion. This permanent opening must be located no less than 12 inches from the bottom of the enclosure or skirting.

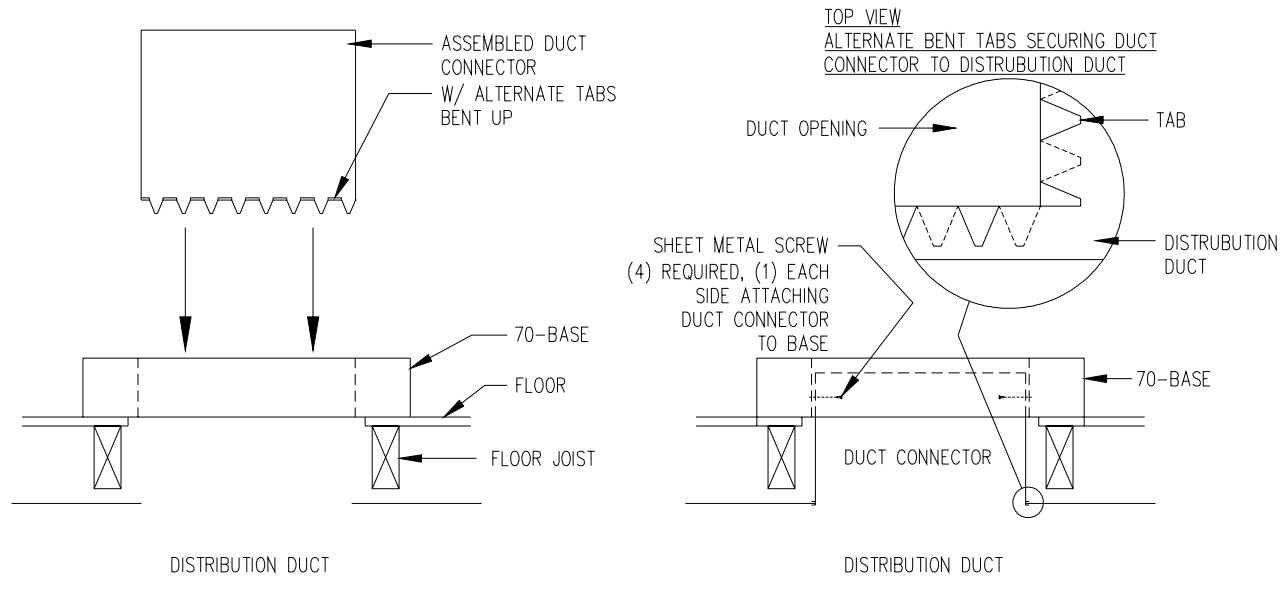

Figure 3.

Slit the corners of feeder duct down to the top of the top panel. If metal projects more than 1 inch above the top panel, trim the flanges down to 1 inch. While the top of distribution duct is being pulled up with one hand, bend down each side of the feeder duct tightly to the top panel with the other hand. This assures a tight connection between the top panel and the feeder duct and that the distribution duct will be full size. Use high temperature tape and/or high temperature silicone caulking on all joints and seams to minimize air leakage. Secure the top panel to the floor with two screws in the front flange.

2. Cottage Base Model: OMCCOT-BASE

The OMCCOT-BASE cottage base (Figure 1B) is required for a freestanding cottage base installation. The cottage base is designed to permit the installation of an 8-inch x 12-inch register in each of the two side panels and the rear panel. This allows combustion air to be drawn from outside, or inside, the structure whichever is appropriate, or permissible. See section **G**.

COMBUSTION AIR for further details regarding combustion air requirements.

All installations and services must be performed by qualified service personnel.

IMPORTANT: Adequate combustion air must be provided under all circumstances. If the underside of the home is skirted or enclosed (e.g. by an enclosed crawlspace), the combustion air intake should exit through the side of cottage base and terminate outside of the structure. All joints and seams of supply ducts and combustion air ducts must be closed with a sealing method suitable to the application conditions and temperatures (e.g. using high temperature silicone caulk and/or aluminum tape).

If the combustion air passageway cannot terminate outside of the structure, a permanent opening with a minimum of 50 square inches of unobstructed infiltration (free area) for ventilation and combustion air must be provided to the interior of the structure. Additional make-up air may need to be supplied to the interior of the structure to compensate for exhaust fans, appliances, or vents which consume air from the interior of the structure.

Refer to the assembly installation instructions included with OMCCOT-BASE cottage base for additional information.

All installations and services must be performed by qualified service personnel.

E. ALCOVE INSTALLATION

In this application, a minimum of 18 inches of clearance **must** be provided to the front of the unit. Refer to Figure 4.

Alcove installations must use the No. 70 mobile home base.

Refer to section **G. COMBUSTION AIR** for additional combustion air requirements.

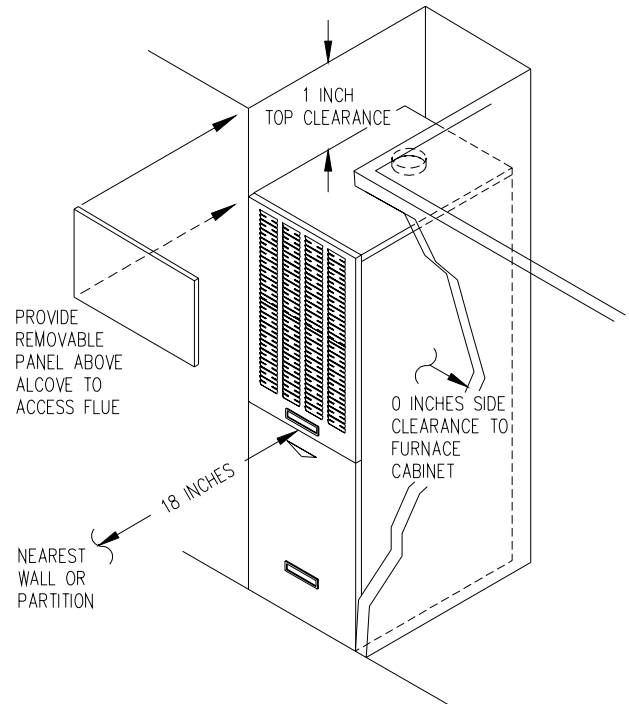

Figure 4.

F. CLOSET INSTALLATION

⚠CAUTION: HAZARD OF ASPHYXIATION: A suction effect will occur when the furnace is operating inside the closet with the closet door closed. For proper operation, the furnace blower shall create no more than a 0.05-inch water column pressure differential between the closet and the adjoining space.

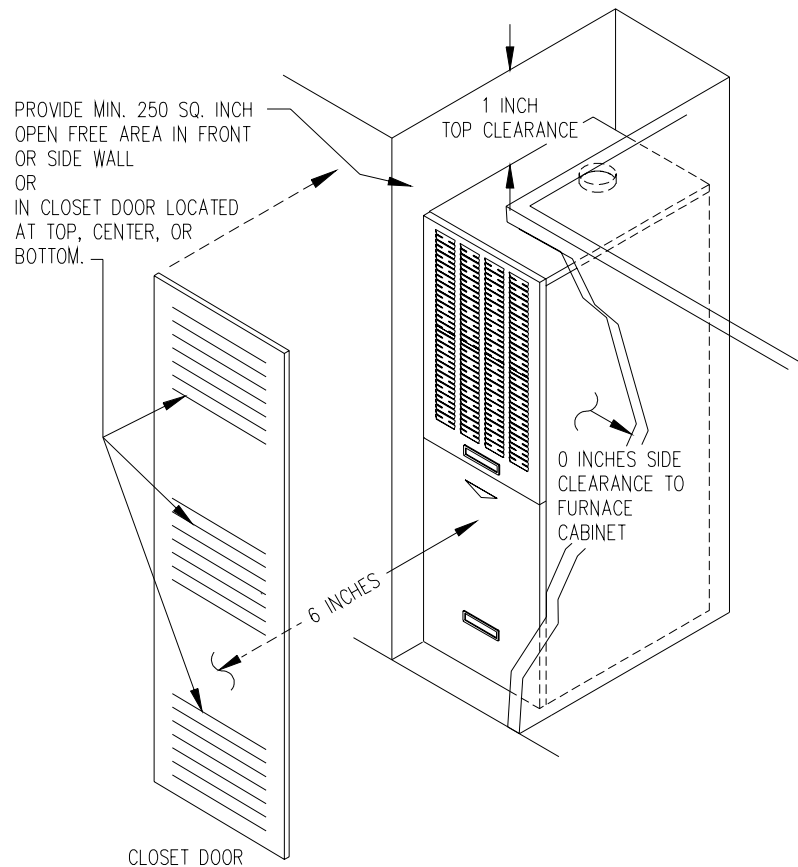

Figure 5.

1. The return air opening into the closet is to have a minimum free area of 250 square inches, (refer to Figure 5).

All installations and services must be performed by qualified service personnel.

2. The return air opening may be located in the top, the center or (ideally) the bottom of the closet door, or side wall.

⚠WARNING: Do not obstruct any return air openings, including the return grille on the furnace. To do so may cause the furnace to activate the high temperature limit and shutdown, or it may cause asphyxiation.

3. The cross-sectional area of the return air duct leading into the closet (when located in the floor or ceiling) shall not be less than 250 square inches.
4. The total free area of openings in the floor or ceiling registers serving the return air duct system must be at least 350 square inches. At least one register must be located where it is not likely to be covered by carpeting, boxes, furniture, or any other objects.
5. Materials located in the return duct system must have a flame spread classification of 200 or less.
6. Pans made of a non-combustible material having 1 inch upturned flanges are to be located beneath openings in a floor, return air, duct system.
7. Wiring materials located in the return air duct system must conform to Article 300-22 of the latest edition of the National Electrical Code, NFPA 70.
8. Gas piping shall not be located in, or extend through, the return air duct system.
9. Refer to section G. COMBUSTION AIR for additional combustion air requirements.

G. COMBUSTION AIR

The furnace requires the proper amount of combustion air be available to combust the fuel cleanly and efficiently. An inadequate combustion air supply can result in unsafe and erratic operation of the burner, sooting of the combustion chamber and the heat exchanger, and possibly, offensive fuel odors. The combustion air intake must provide an adequate source of combustion air to the appliance. Refer to part 5.3 of the National Fuel Gas Code, ANSI Z223.1 / NFPA 54-1999, or latest edition for application specific combustion air requirements.

All installations and services must be performed by qualified service personnel.

The preferred location of the outside combustion air intake termination (e.g. an optional stainless steel intake hood, part no.370183) is through the side of the structure, skirting or enclosure. An alternate termination location is under the structure in the skirted or crawlspace area providing a minimum of 50 square inches of free area exists around the perimeter for outside combustion air to be drawn through.

The furnace is shipped with a combustion air duct that must be installed in the bottom of the burner enclosure, before the burner is installed. This 2-inch by 7-inch duct is shipped in two pieces. High temperature silicone sealant should be applied to both vertical seams, before it is snapped together with four flanges on one end. The duct must then have high temperature silicone applied to the flanges. Then, the combustion air duct can be inserted through the opening in the floor base model no.70. When the combustion air duct has been inserted completely, secure the duct to the combustion adapter with self-tapping sheet metal screws, refer to Figure 6. Make certain that the flanges, duct, and adapter are completely sealed to the burner enclosure base with high temperature silicone caulk.

NOTE: The adapter may be cut with sheet metal shears to the appropriate size and secured over the inlet air duct opening. The adapter will convert the rectangular opening to a round connector ring. The ring will allow the connection of 2-inch I.D. flexible hose (provided) between the adapter and the inlet air boot, attached to the burner. Secure both ends of the flex hose with hose clamps (provided).

A 2-inch round to 7-inch x 4-inch rectangular, sheet metal, transition boot is supplied with the furnace for adapting a 4-inch round combustion air duct to the 2-inch x 7-inch combustion air duct. This boot has a screen inserted into the 4-inch round portion of the boot to provide a degree of protection from pests entering the furnace when the boot is terminated in the crawl space, or skirted area, directly below the furnace.

The material recommended for the combustion air duct is smooth, round, galvanized steel duct or schedule 20 PVC pipe. The maximum duct length allowed is equivalent to 40-feet of straight duct. Reduce this length by 6-feet for the intake hood and each 90-degree elbow used, and by 3-feet for each 45-degree elbow used the combustion air duct. Flexible, spiral, or corrugated duct is not recommended, due to the relatively high pressure drop associated with air movement through this type of passageway.

All installations and services must be performed by qualified service personnel.

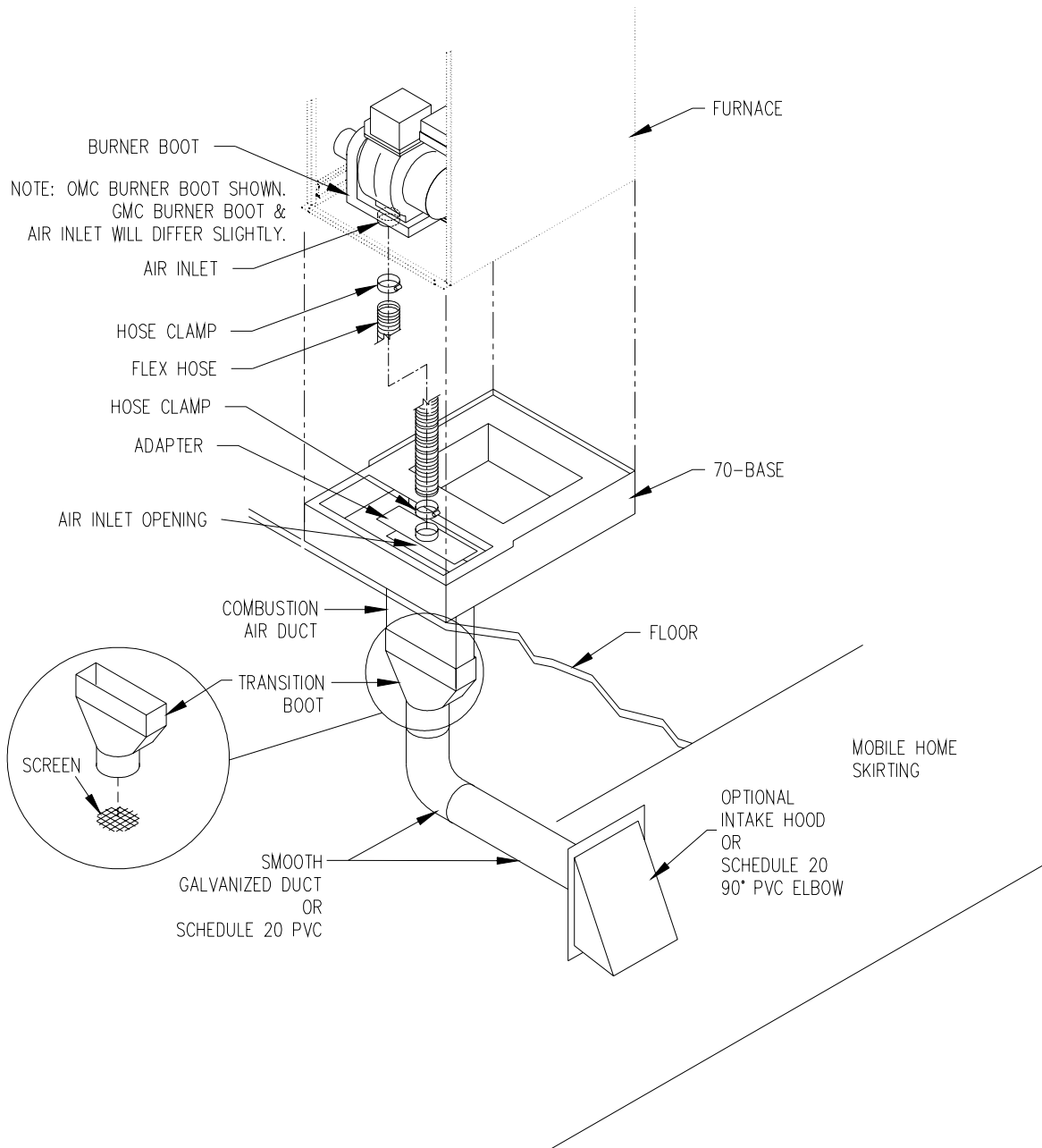

Figure 6.

All installations and services must be performed by qualified service personnel.

H. FUEL PIPING

Sizing and installation of fuel lines must be in accordance with federal, state and local regulations.

1. General Gas Piping (GMC-85)

⚠WARNING: Because of the potential of the odorant to fade, a gas leak may not be detected by smell. If this furnace is installed below grade, contact your gas supplier for a gas detector.

A qualified installer or service person must install all gas piping and perform all required testing. Piping from the natural gas meter to the furnace shall be in accordance with requirements of the local gas utility. Piping from the propane tank to the furnace must follow the recommendations of the gas supplier. In the absence of local codes governing gas piping selection and installation, follow the National Fuel Gas Code, ANSI Z223.1 / NFPA 54-1999, or latest edition.

A readily accessible, manual gas shutoff valve (design-certified for the applicable gas) with a non-displaceable rotor member shall be installed within six feet of the furnace.

A pipe union, or flanged connection, shall be provided directly up stream of the burner to allow burner removal. Unions must be of a ground joint type or flange-jointed type using a gasket resistant to the corrosive effects of LP gases. Pipe dope or sealant design-certified to be resistant to the action of the LP gases should be used on all threaded joints.

The burner is setup to be piped to the gas supply through the left-hand side of the furnace. For service purposes, it is recommended the gas union be located inside the furnace.

A drip leg must be used on both propane and natural gas installations immediately upstream of the furnace in order to trap oil, condensate, and other impurities which might otherwise lodge in the gas valve, or plug the main burner orifice. A drip leg shall be provided at the outlet of the gas meter when there is excessive condensation between the gas meter and the furnace.

Failure to install drip leg(s) may void the manufacturer's limited warranty on the furnace.

⚠WARNING: With the gas piping pressurized, all gas piping connections must be leak tested using a strong soap and water solution. Any leaks must be repaired immediately after turning off the gas supply. A final test for gas leakage must be made after purging the gas line.

⚠CAUTION: DO NOT wet electronic components during the leak test. Wetting electronic components may damage circuitry and cause a hazardous situation. Dry moisture from all leads and terminals if wetting occurs. Wait at least 24 hours for the circuit to fully dry before energizing the system.

All installations and services must be performed by qualified service personnel.

⚠WARNING: *The furnace and its gas valve must be disconnected from the gas supply during pressure testing of the gas supply system at pressures in excess of 1/2 PSIG (13.9 inches W.G.). The furnace can be isolated from the gas supply by closing the manual gas shutoff valve serving the appliance at test pressures equal to, or less than, 1/2 PSIG or (13.9 inches W.G.).*

⚠WARNING: *Copper and brass tubing and fittings (except tin lined) shall not be used if the gas contains more than a trace (0.3 grains per 100 cubic ft.) of hydrogen sulfide gas. Check with your gas supplier.*

For natural gas, the maximum supply pressure is 13.9 in. W.G. and the minimum supply pressure, for purposes of input adjustment, is 4.5 in. W.G.

For propane gas, the maximum supply pressure is 13.9 in. W.G. and the minimum supply pressure, for purposes of input adjustment, is 11.5 in. W.G.

2. Oil Tank and Piping (OMC-70)

⚠WARNING: *All local codes and ordinances take precedence with regard to tank and oil lines. All lines must have oil shutoff valves, a good pipe joint compound approved for use with oil on all pipe threads, no kinks; no sharp bends and be properly tested for leaks. Flare fittings are recommended for tubing.*

⚠CAUTION: *Do not run the oil pump dry for more than five minutes.*

Your furnace is factory equipped to operate on No. 2 distillate fuel (domestic heating) oil. In very cold weather, No. 1 distillate fuel oil may be used. Your oil supplier should be contacted for recommendations.

⚠CAUTION: *Do not use motor oil or any fuel other than No. 1 or No. 2 fuel oil in this furnace.*

Burners are most commonly installed with a single stage fuel pump (refer to Figure 7). This type of fuel pump, when connected with a supply line only, is satisfactory where the fuel supply is level with, or above, the burner. This type of installation permits gravity flow of oil to the burner. When it is necessary to “lift” (raise) oil to the burner, a return line should be connected between the fuel pump and tank. This requires insertion of the “by-pass” plug into the fuel pump. If the lift exceeds approximately 10 feet, a two-stage pump should be installed with a return line. When a return line is used with either single or two-stage pumps, air is automatically returned to the tank, making the unit self-purging.

Use of continuous runs of heavy wall copper tubing is recommended. Always use flare fittings. Avoid use of fittings in inaccessible locations. **Avoid running tubing against any type of heating unit and across ceiling or floor joists.**

All installations and services must be performed by qualified service personnel.

If possible, install the tubing under the floor. Specific information on piping, fuel pump connections, lift capabilities and tank installations is provided in the fuel pump manufacturer's instructions.

If the oil tank is located inside the building and the tank capacity is between 10 and 660 gallons, it shall not be located within 5 feet horizontally from any source of heat, or oil-burning appliance. Furthermore, the oil tank shall not block access to utility service meters, switch panels, and shutoff valves.

If an underground tank used, the top of the tank should be below all piping in order to prevent oil discharge through a broken connection. Underwriters Laboratories requirements now stipulate that all 275 gallon and larger tanks have a bottom outlet. This is to prevent the accumulation of condensate, which causes the tank to rust. It is also recommended to use a water trap or additives to prevent condensate accumulation.

If the tank is above the burner, and gravity oil feed to the burner is permitted, a single line system may be used. The line should have a gradual slope downward of approximately 1/2 inch per foot, or more, to a point directly below where it is connected to the pump. Installing the line with a downward slope will help prevent the formation of air pockets in the line.

IMPORTANT: An oil safety valve or a delayed-action solenoid valve is required with all gravity feed oil supply systems.

IMPORTANT: The oil storage tank must be free of water, sludge and scale to prevent excessive wear and possible damage to furnace oil pump and burner nozzle. A fuel oil filter installed in the oil supply line to the burner is required.

OIL FILTER: For all installations, use a low micron, oil filter with the capacity to trap particles 10 microns in diameter, or greater. Filtering the oil supply helps to prevent nozzle clogging. Install the oil filter inside the building between the tank shutoff valve and the burner. The filter cartridge should be replaced at least once a year. The filter body should be thoroughly cleaned before installing a new cartridge.

All installations and services must be performed by qualified service personnel.

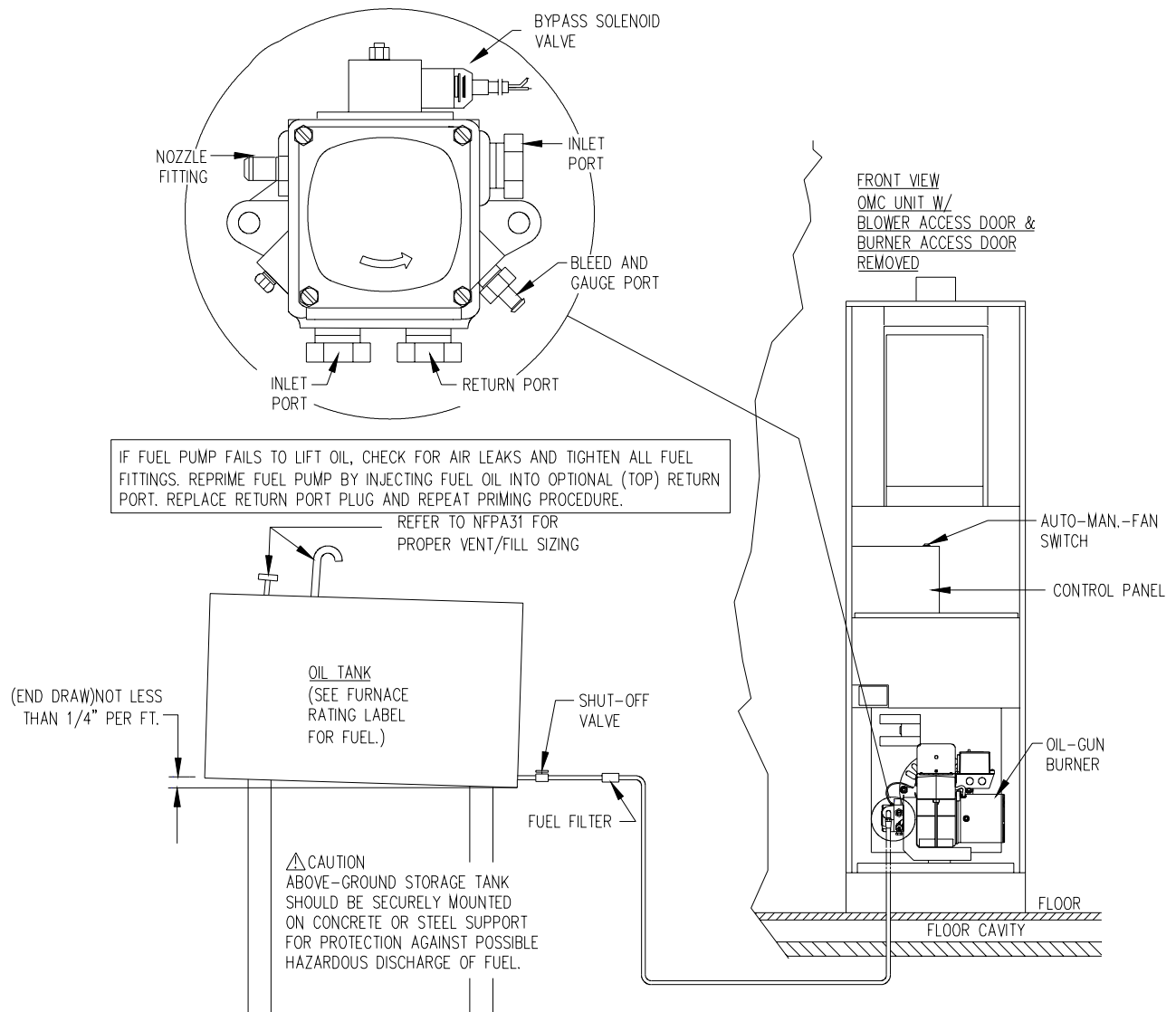

Figure 7.

J. ELECTRICAL WIRING

All electrical wiring must be installed in strict accordance with local ordinances and codes. In the absence of local ordinances and codes, all electrical wiring must conform to the requirements of the National Electric Code, ANSI/NFPA 70-1999, or latest edition.

CAUTION: *When testing electrical equipment, always follow standard electrical procedures and precautions.*

All installations and services must be performed by qualified service personnel.

1. Electrical Branch Supply Circuit

Route all electrical wiring to the left side of the furnace. The power supply circuit to the furnace must be installed and grounded in accordance with the provisions of the National Electrical Code, ANSI/NFPA-70-1999, or latest edition, and all local codes having jurisdiction.

2. Connection Of Power Supply Wires

- a. Remove the furnace control panel cover.
- b. Insert 120 VAC wires through the strain relief bushing (or conduit connection as applicable) on the left side of the furnace junction box.
- c. Connect the “Hot” wire to the terminal block lug marked “L₁”.
- d. Connect the “Neutral” wire to the terminal block lug marked “L₂”.
- e. Connect the “ground” wire to the terminal block lug marked “G”.
- f. Reinstall and secure the control panel cover with the original mounting screws.

3. Connection Of Thermostat Wires

NOTE: Class 1 thermostat wire must be used inside the furnace burner compartment.

- a. Insert 24 VAC wires through the plastic grommet on the left side of the furnace casing.
- b. Connect the thermostat wires to the yellow leads from the burner (refer to the applicable wiring diagram).
- c. Connect the thermostat wires to the room thermostat.

IMPORTANT: The room thermostat should be installed 4 to 5 feet above the floor on interior wall which is relatively free from direct sources of heat (sunlight or supply airflow) or exposure to cold (drafts from open windows and doors). The nominal anticipator settings are 0.8 amperes, for the GMC, and 0.2 amperes, for the OMC (refer to the thermostat literature for additional information).

Five-conductor thermostat wire is recommended for 24 VAC, low-voltage, control circuit wiring. Only 2 wires are required for the furnace (a heating application only).

Electrical Wire Diameter (AWG)	Maximum Recommended Thermostat Wire Length (feet)
24	55
22	90
20	140
18	225

All installations and services must be performed by qualified service personnel.

Once the furnace is installed, check the thermostat anticipator the proper nominal setting.

- a. Connect a multimeter, capable of reading milliamps (mA), in series with the low voltage wires to the thermostat.
- b. Increase the thermostat setting, or create a “call for heat”.
- c. Read the value of the thermostat current, in milliamps.
- d. Adjust the heat anticipator of the thermostat to the value read by the multimeter.

If the heat anticipator is set too high, the furnace may delay activation of a heating cycle for too long. If the heat anticipator is set too low, the furnace may cycle too frequently. Either condition may not provide optimal comfort to the homeowner.

All installations and services must be performed by qualified service personnel.

4. WIRING DIAGRAM

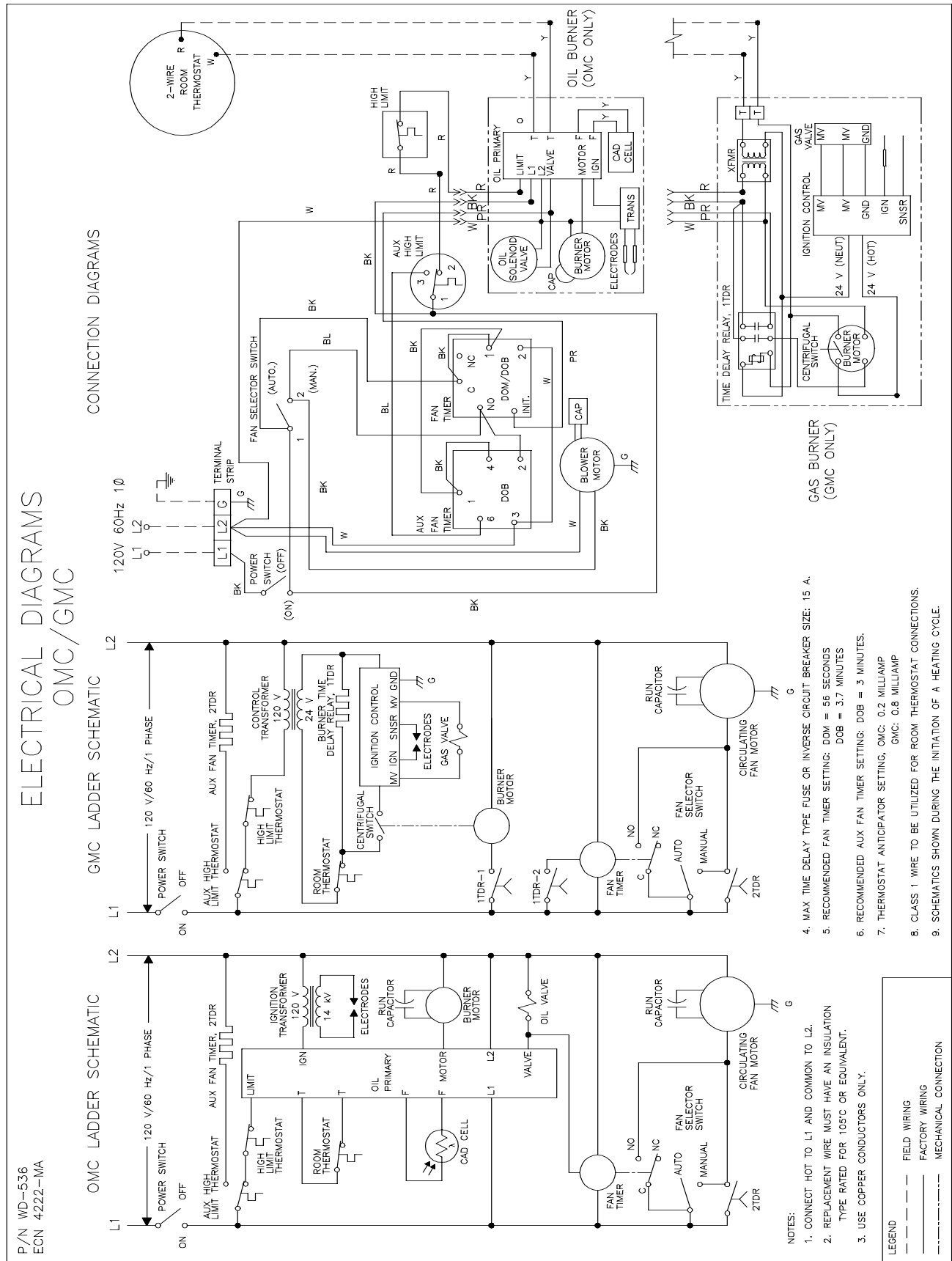

All installations and services must be performed by qualified service personnel.

K. BURNER INSTALLATION

The burner mounts to the furnace on three mounting bolt studs, located on the burner mounting plate, in the lower portion of the vestibule, directly in front of the heat exchanger.

The burner insertion depth has been fixed by the factory for the design-specified, combination of the air tube length and the combustion chamber used with the furnace. The combustion chamber is pre-positioned during the assembly process and held in place by the drum and mounting plate. The burner insertion depth is not field-adjustable.

Should access to the chamber be necessary, refer to the exploded diagram, in the back of this manual, to identify replacement parts.

To install and ready the burner for firing, follow the steps below for both furnace models.

1. With electrical power connected to the furnace, turn off all electrical power to unit.
2. Remove the front lower access panel.
3. Mount the burner to the furnace. Install the flange gasket over the mounting studs and secure the burner flange to the furnace using hex head machine screw nuts, provided in the Parts Kit.
4. Connect the burner multipin electrical connector to the multipin connector in the furnace vestibule wiring harness.

For the oil burner installation (OMC) only:

5. Determine whether an oil return line is required and connect the fuel oil piping to the burner oil pump through the base of the unit.
6. Turn on electrical power to the furnace. Cause or simulate a “call for heat” to bleed air from the oil line at the oil pump. (Temporarily, connect the two thermostat leads to cause the oil pump to run.)
7. With all oil shutoff valves open, open the air-bleed valve on the oil pump and capture the oil flow in a container until all traces of air in the line are gone.
8. Close the air-bleed valve. Check for and correct any oil leaks. The furnace is now ready for burner adjustment, refer to the following “BURNER OPERATION AND ADJUSTMENT” section.

For the gas burner installation (GMC) only:

5. Connect the gas piping to the burner through the base of the unit.
6. With all gas shutoff valves open, bleed air from the gas line by opening the pipe union closest to the furnace a small amount. Carefully, close the pipe union when the odor of gas becomes strong. Check for and correct any subsequent gas leaks.

Wait five (5) minutes for any lingering gas to dissipate.

7. Turn on electrical power to the furnace.

All installations and services must be performed by qualified service personnel.

8. The furnace is now ready for burner adjustment, refer to the following “BURNER OPERATION AND ADJUSTMENT” section.

L. BURNER OPERATION AND ADJUSTMENT

⚠WARNING: NEVER burn garbage or refuse in the furnace. NEVER try to ignite oil or gas by tossing burning papers or other material into your furnace.

⚠WARNING: If you do not follow these instructions exactly, a fire or explosion may result causing personal injury, loss of life or property damage.

⚠WARNING: NEVER use gasoline or a mixture of oil and gasoline to start the burner or furnace.

1. Qualified service personnel must perform the first lighting of the burner.
2. The burner instructions must be read and understood before any attempt is made to light this burner.

NOTE: For the sequence of burner operations, see individual burner manual. To successfully service and initially set up this furnace, you must use the following instruments:

[Items (a)-(e) ... apply to both oil and gas furnaces), item (f) ... applies to gas units only, and items (g)-(h) ... applies to oil units only]

- a. Carbon dioxide (CO₂) or oxygen (O₂) analyzer.
- b. Flue gas thermometer (range 100°F to 1000°F) and temperature-measuring device (range -40°F to 240°F, for return and supply air temperatures).
- c. Carbon monoxide (CO) detector
- d. Electrical multimeter
- e. Liquid, U-tube type manometer or equivalent pressure measuring instrument (range: 0 – 28 in. W.G.)
- f. Smoke spot tester or equivalent smoke density measuring device
- g. Oil pressure gauge (range: 0-150 PSIG)
- h. Vacuum gauge (range: 0-30 in. W.G. vacuum)

Turn the main service switch that provides power to the furnace to the “off” position. Set thermostat above room temperature, open all fuel supply valves. Bleed air out of fuel supply line, if not already completed (for oil, power must be “on” to the burner and the pump must be operating to expel air in the supply line).

When ignition is established, if necessary, make a preliminary burner air adjustment to attain a clean combustion flame (one which does not create smoke by eye). On the GMC unit, the flame may be viewed through a sightglass mounted on the burner. On both units, the flame may be viewed through the overfire inspection cover (see exploded diagram of

All installations and services must be performed by qualified service personnel.

replacement parts for location identification). After the furnace is warmed up to a steady-state condition (about 15 minutes), the final burner adjustment should be made using combustion instrumentation for measuring carbon dioxide (CO₂) or oxygen (O₂), carbon monoxide (CO), smoke (for oil furnaces), and stack temperature. In order to achieve the most efficient combustion possible, the following steps must be taken.

IMPORTANT: To achieve proper combustion and efficiency instruments must be used to secure CO₂, O₂ and CO readings.

1. **CARBON DIOXIDE (CO₂) or OXYGEN (O₂):** Take a CO₂ sample from the flue pipe or vent connector at a position close to the furnace. It is possible to achieve relatively high CO₂ (or low O₂) readings with low stack temperatures to produce maximum combustion efficiency. However, the CO₂ and O₂ values recommended are slightly less, though this means slightly lower efficiency, to allow the burner to better tolerate adverse operating conditions, such as a cold heat exchanger, downdraft conditions, heating content changes in the fuel. This working tolerance means less service and maintenance during heating seasons as well as a reduced chance of producing carbon monoxide under adverse conditions.
2. **CARBON MONOXIDE (CO):** As described above, take a flue gas sample from the flue pipe or vent connector at a position close to the furnace. The amount of CO generated by combustion ideally should be zero or only a trace. In all cases, it must be less than 50 PPM. Carbon monoxide is a colorless and odorless gas, but it is toxic compound. The production of significant quantities of CO is a strong indicator of incomplete combustion. Check the fuel supply and the burner for fuel leakage. Check for an inadequate supply of clean air for combustion. Also, check for a restricted or blocked flue, vent, or chimney.
3. **SMOKE:** (oil burners only) A smoke sample should be drawn from the flue pipe or vent connector at a position close to the furnace. For the greatest efficiency, if the first smoke reading is "0", close the air shutter on the burner until a trace smoke reading is obtained.
4. **FLUE GAS TEMPERATURE:** The flue gas temperature will vary to some degree depending on the heating content of the fuel, the amount of combustion air, and airflow across heat exchanger. In general, the lower the stack temperature, the higher the efficiency. However, stack temperatures under 350°F may cause flue gases to condense, which in turn may cause excessive metal corrosion.
5. **TEMPERATURE RISE:** Supply air temperature (measured twelve inches into trunk, away from radiant heat from the furnace) minus (-) return air temperature, or

Temperature rise = Supply air temperature - Return air temperature.

All installations and services must be performed by qualified service personnel.

The temperature rise across the furnace heat exchanger operating at steady-state conditions (about 15 to 20 minutes) should not exceed 100°F. The normal comfort range is between 70°F to 100°F. A lower temperature rise usually results in a higher system efficiency.

⚠CAUTION: *If the temperature rise exceeds 100°F, the heat exchanger may fail, voiding the heat exchanger warranty resulting in property damage, personal injury or loss of life.*

M. FLUE GAS COMBUSTION ANALYSIS

⚠WARNING: *Burner adjustments must be confirmed by instrumentation. Failure to use accurate or calibrated instrumentation to correctly setup the burner may result in reduced efficiency, sooting, and/or the production of hazardous carbon monoxide gas.*

For typical burner combustion analysis results, refer to the table below.

BURNER COMBUSTION PARAMETERS

FURNACE MODEL	OMC-70	GMC-85	
FUEL TYPE	#1 OR #2 FUEL OIL	NATURAL GAS	PROPANE GAS
CO (CARBON MONOXIDE)	<u>50PPM OR LESS</u>	<u>50PPM OR LESS</u>	<u>50PPM OR LESS</u>
CO ₂ (CARBON DIOXIDE)	11-12%	8.75-10%	9.5-11%
O ₂ (OXYGEN)	4.5-6%	5.9-3.8%	6.7-4.5%
SMOKE SPOT RATING	0 TO TRACE	N/A	N/A
AIR SHUTTER ADJUSTMENT	OPEN TO POSITION 35	OPEN TO POSITION 4	OPEN TO POSITION 4

N/A = NOT APPLICABLE

All installations and services must be performed by qualified service personnel.

V. DEALER MAINTENANCE

THIS SECTION IS ONLY TO BE PERFORMED BY TRAINED, QUALIFIED SERVICE PERSONNEL, AND NOT BY THE FURNACE OWNER.

A. TROUBLESHOOTING

⚠CAUTION: *When testing electrical equipment, always follow standard electrical procedures and precautions.*

1. Check for line voltage (110-120VAC) to the furnace. If there is no line voltage applied to the furnace, check that disconnecting switch is “on”, fuses or circuit breakers have not blown or tripped.
2. Make sure thermostat is “calling for heat”.
3. Check for adequate fuel supply and pressure. Are all the fuel shutoff valves are open?

All installations and services must be performed by qualified service personnel.

OMC/GMC TROUBLESHOOTING FLOWCHART

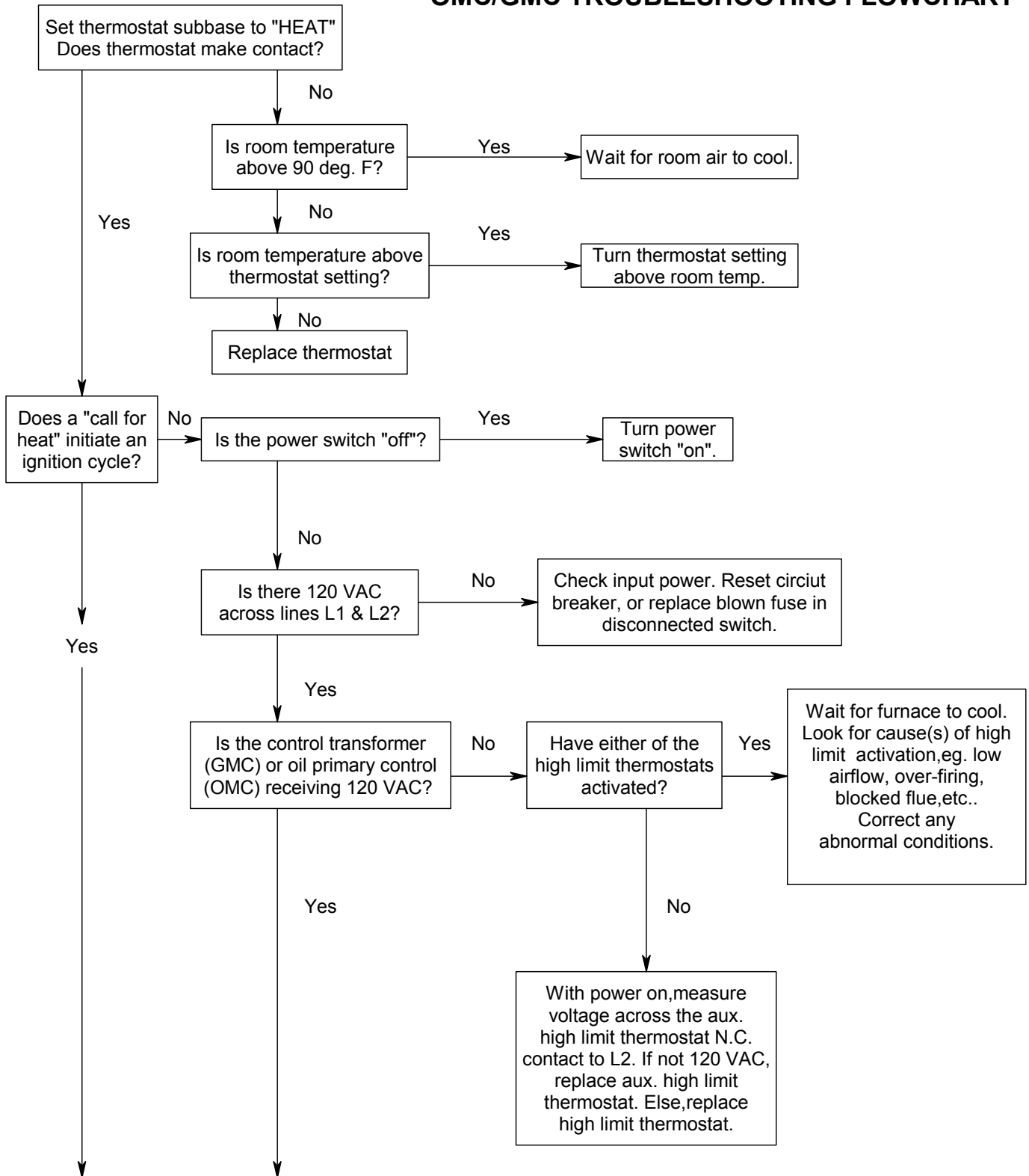

All installations and services must be performed by qualified service personnel.

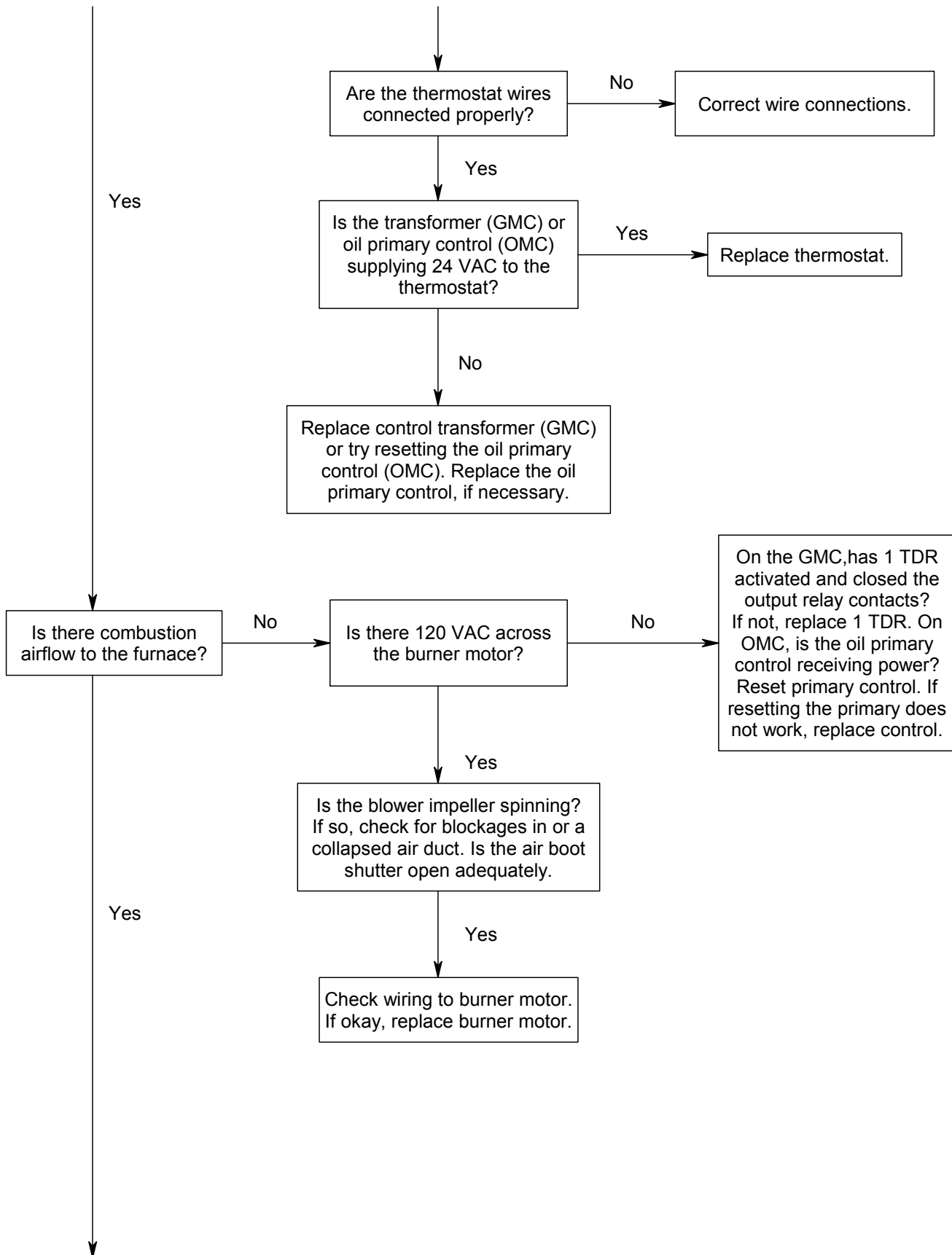

All installations and services must be performed by qualified service personnel.

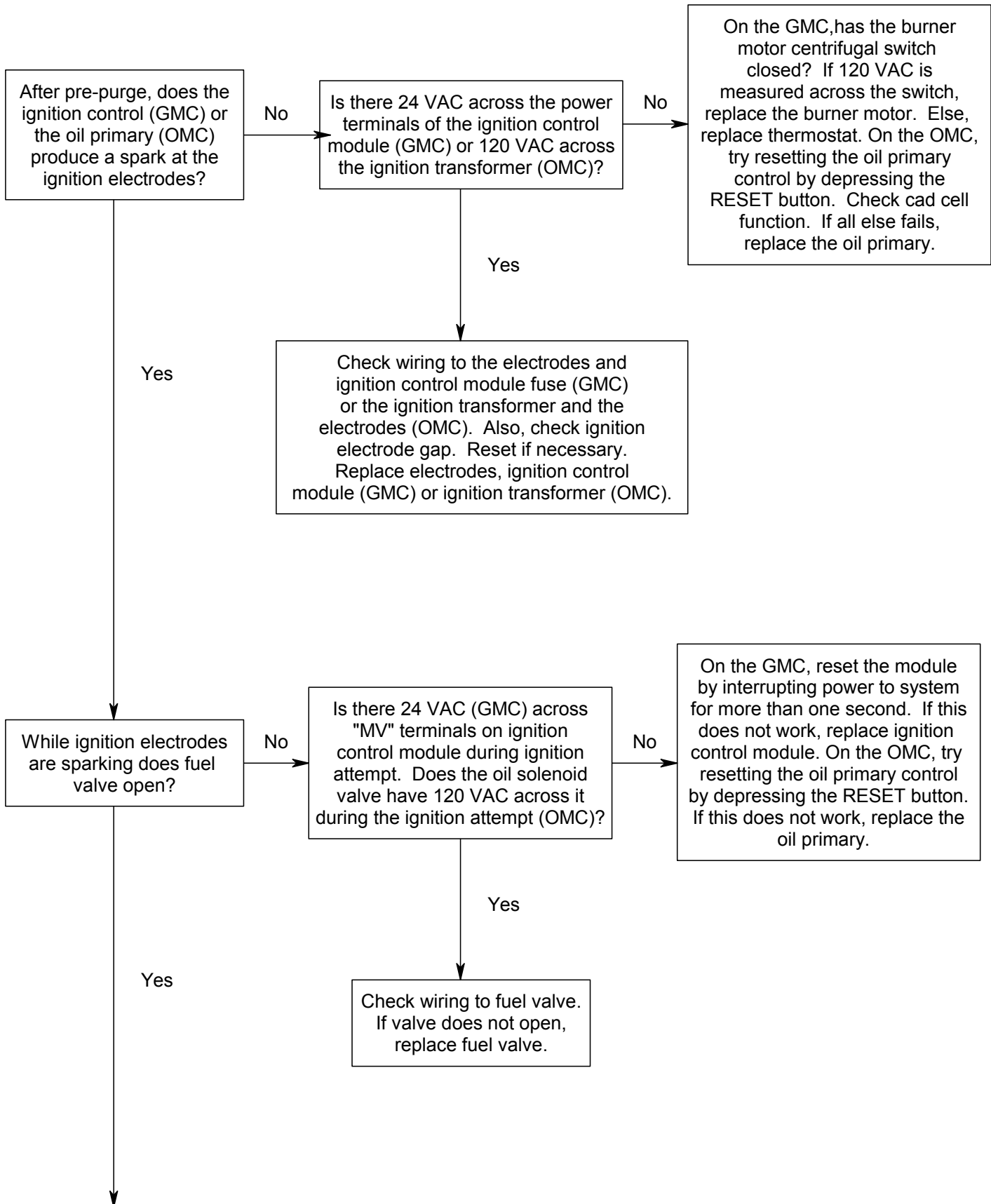

All installations and services must be performed by qualified service personnel.

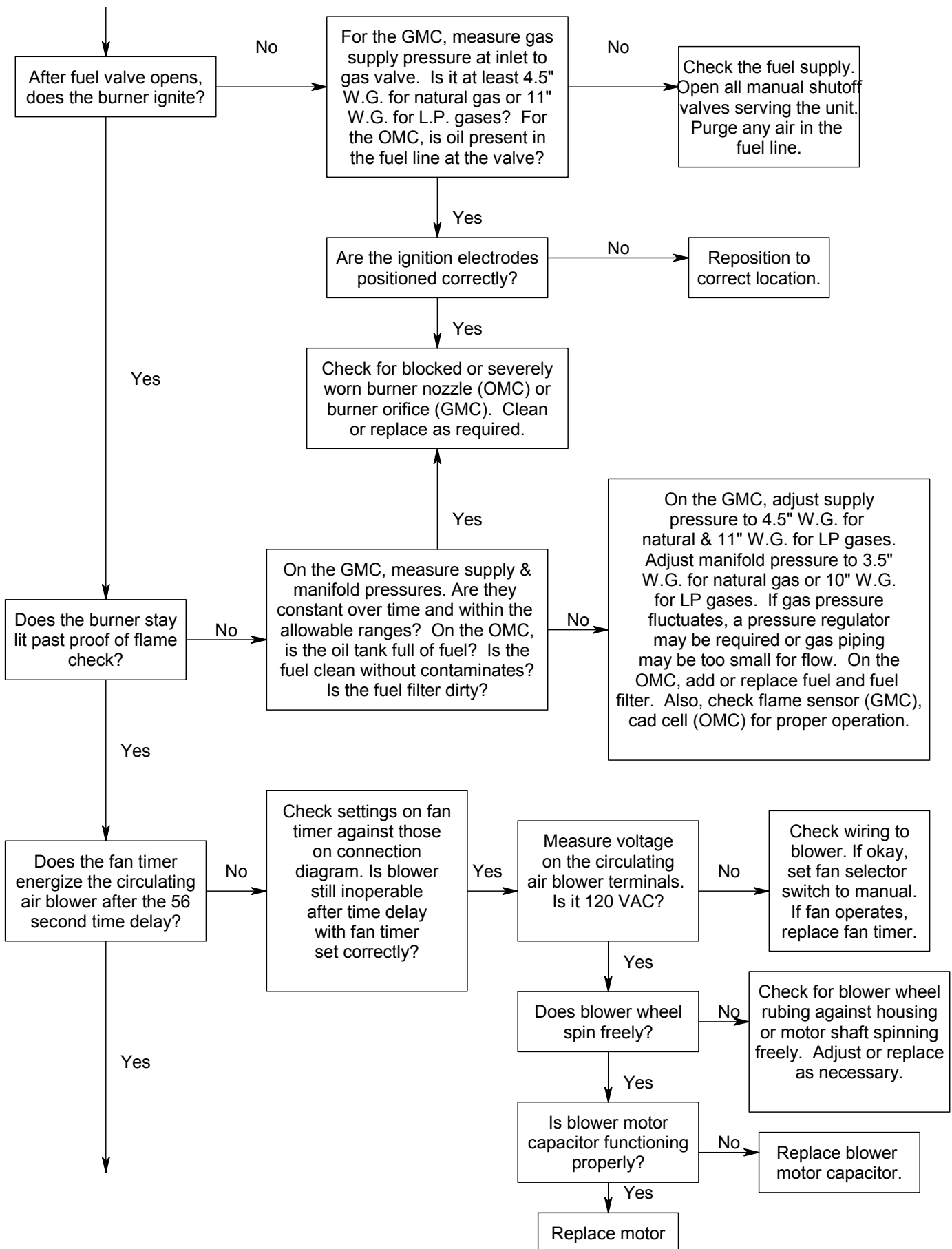

All installations and services must be performed by qualified service personnel.

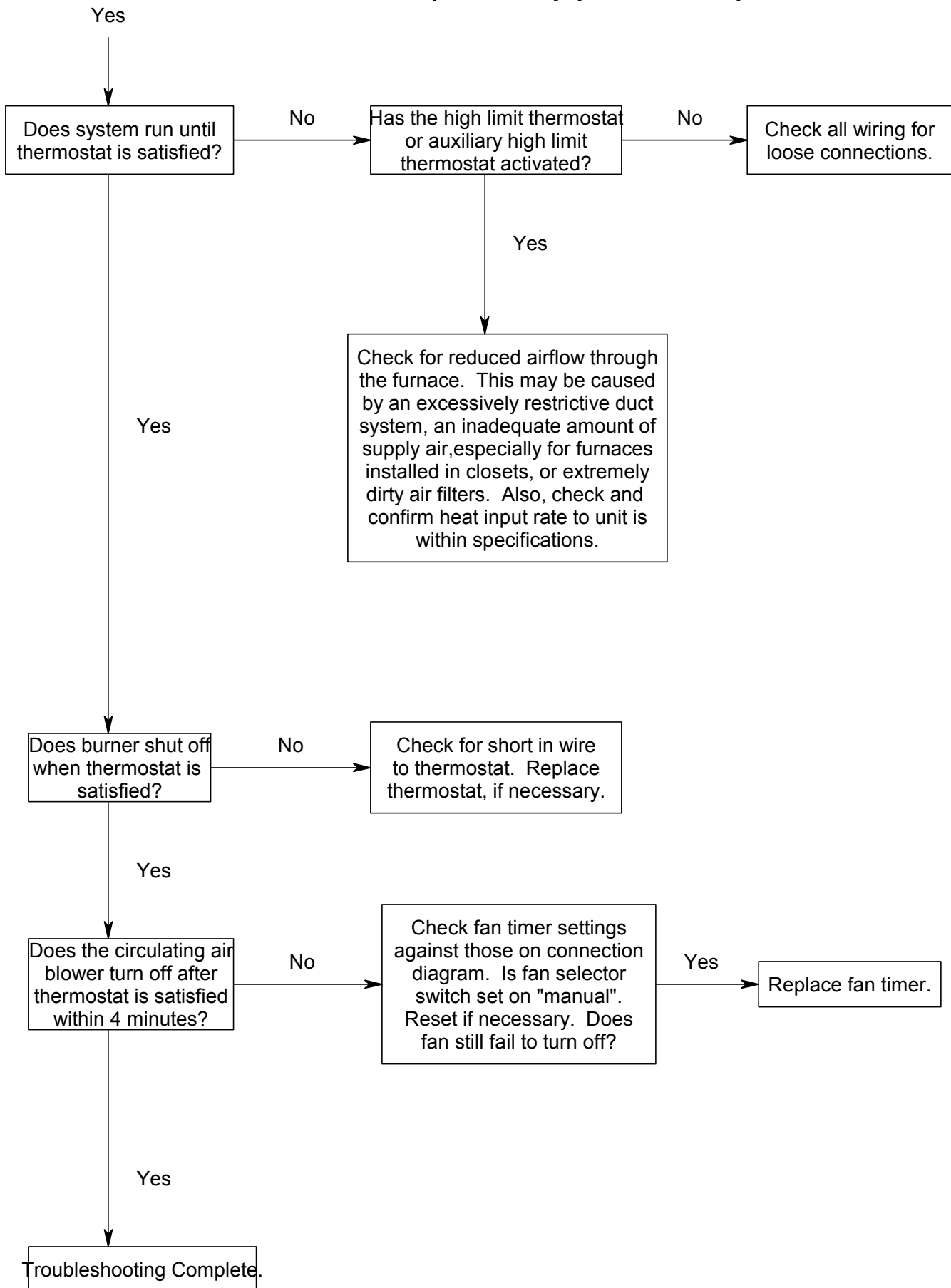

All installations and services must be performed by qualified service personnel.

B. CAD CELL CHECKOUT PROCEDURE: (OMC ONLY)

1. Remove cad cell lead wires, then start the burner. Shortly after burner starts, place a temporary jumper between terminals f & f of the oil primary control. Connect ohmmeter across cad cell lead wires - resistance should be less than 1600 ohms.
2. Stop the burner and remove temporary jumper.
3. With the burner off, check dark cell resistance across cad cell lead wires. Resistance should be greater than 20,000 ohms. If cell resistances are different from above, recheck wiring, location of cell, etc. If necessary, replace plug in portion of cell, (Part No. 350104).
4. Reconnect cad cell lead wires. Check out the oil primary control according to the instructions packed with the control.

All installations and services must be performed by qualified service personnel.

C. HEAT EXCHANGER CLEANING INSTRUCTIONS

⚠WARNING: *The heat exchanger must be cleaned by a qualified service person.*

For oil-fired units, it is important to inspect and clean the heat exchanger once a year, or as necessary, to remove any build-up of soot. A layer of soot on the inside of the heat exchanger will act as an insulator, reducing heat transfer, resulting in reduced efficiency

For gas-fired units, the presence of a layer of soot on the heat exchanger is a strong indicator of incomplete combustion. The burner adjustment should be rechecked as well as the firing rate, the combustion air supply, and the vent system.

To clean the heat exchanger,

1. First, turn off all power to the unit.
2. Remove the clean-out plate, immediately above the burner (refer to Figure 8), to gain entry to the cleanout covers.
3. Remove cleanout covers, the vent connector pipe to the chimney, the burner and the burner mounting plate. When removing the cleanout cover, special care must be taken not to damage the gaskets or high limit switch.

NOTE: The high limit switch may be removed for easier access to the left-hand cleanout cover by removing the two (2) limit mounting screws. The limit must be reinstalled in the original orientation before operating the furnace.

Should the gaskets separate, crack, break, or otherwise not be able to provide the necessary seal, the gasket must be replaced before reattaching the cleanout cover.

4. With access to the inside of the heat exchanger through the burner cleanout openings and the vent pipe connection, it is now possible to use a long, flexible wire brush and an industrial-type vacuum cleaner to remove any soot build-up.

NOTE: A one inch (outside diameter) vacuum cleaner hose will fit into the radiator.

To vacuum and brush the outer radiator of the heat exchanger, go through the cleanout openings in both directions, as shown in Figure 8.

All installations and services must be performed by qualified service personnel.

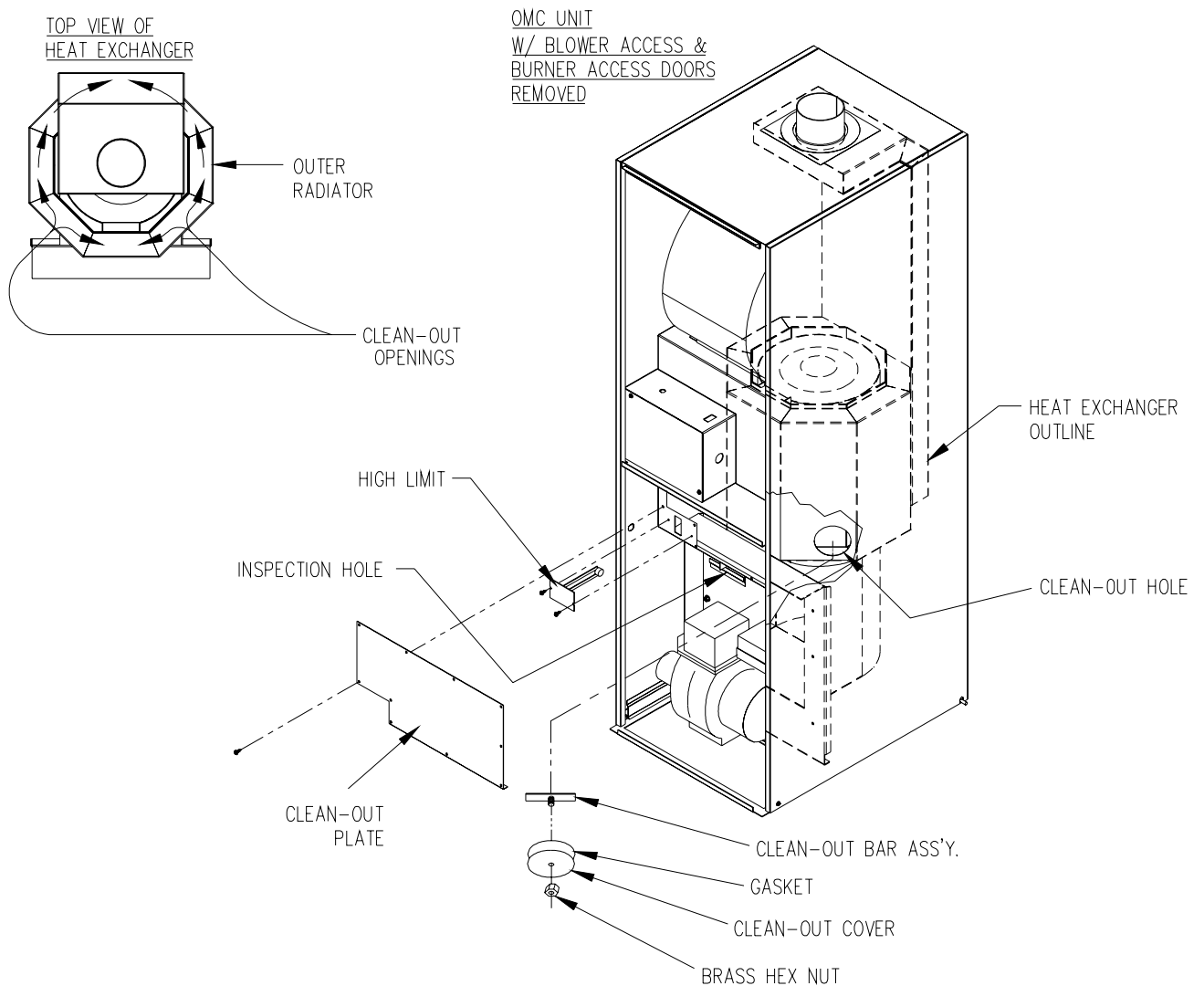

Figure 8.

Reassemble the furnace to the original factory-built condition. Remount the burner, being certain that the air tube is properly inserted into the chamber opening. If heavy soot deposits were found in the heat exchanger, this indicates that the burner may be out of adjustment. Reset the burner, as indicated under the "BURNER OPERATION AND ADJUSTMENT", SECTION L.

D. CLEANING OR REPLACING FLUE PIPES

Flue pipes should be inspected during the annual maintenance check-up or during each subsequent service call.

All installations and services must be performed by qualified service personnel.

Check all flue pipes for restrictions due to soot, or carbon build-up, as well as foreign matter, or any materials, that cause the venting system to restrict the proper venting of combustion products. If a restriction is found, the flue pipe **must** be cleaned or replaced to ensure proper venting.

Flue pipes should also be inspected for any signs of corrosion, deterioration or leakage that may cause combustion by-products to infiltrate the home or indoor environment.

If signs of corrosion, deterioration or leakage are evident, the flue pipe **must** be replaced with a properly sized, agency-approved, flue pipe.

E. EXTENDED SHUTDOWN

If this furnace is shut down or off for an extended period of time, several steps can be taken to help insure a smooth and reliable start.

ON SHUT DOWN:

1. Close the fuel supply shutoff valve(s).
2. Turn the furnace power switch “off” and disconnect electrical power to the unit.
3. Fill the oil tank to prevent condensation (oil units only).
4. If shutdown exceeds one season, an oil stabilizer should be added to the oil tank as recommended by your oil supplier (oil units only).

ON START-UP:

1. Have the heating system (and furnace) inspected and started by a qualified service person.
2. Check for a clean, adequate supply of fuel.
3. Set the room thermostat above room temperature.
4. Open all shutoff valves in the fuel supply line.
5. Turn “on” the main power at the disconnecting switch and at the furnace power switch to start the burner. If the burner does not start, immediately reset the burner primary (ignition) control module. On oil furnaces, if required, vent the fuel of air as soon as the burner motor starts. If the burner stops during venting, wait three to five minutes before attempting to restart.

⚠CAUTION: Do not attempt to start burner when excess fuel has accumulated inside the furnace.

6. Follow the “BURNER OPERATION AND ADJUSTMENT” procedure in Section L.

All installations and services must be performed by qualified service personnel.

VI. USER INFORMATION SECTION

A. WARNINGS AND CAUTIONS:

⚠WARNING: *If you suspect there is a problem with the furnace, pertaining to the venting system or any other related problem, immediately contact a qualified service agency. If a service agency is not available, contact your fuel supplier.*

⚠WARNING: *Personal injury or property damage could result from major repair or service of this furnace by anyone other than a qualified contractor. The user should only perform the routine maintenance described in the user section of this manual.*

⚠WARNING: *The area around the furnace should be kept free and clear of combustible materials, especially papers and rags.*

⚠WARNING: *Never burn garbage or refuse in your furnace. Never try to ignite oil or gas by tossing burning papers or other material into the furnace.*

⚠CAUTION: *Do not attempt to start the burner when:*

- 1. Excess oil or gas has accumulated,*
- 2. The furnace is full of vapors,*
- 3. The combustion chamber is very hot.*

If one or more of these conditions exist, contact a qualified service person.

⚠CAUTION: *Do not block or obstruct air openings on the furnace casing. Do not block or obstruct air openings communicating within the area in which the furnace is installed.*

⚠CAUTION: *Do not allow the outside air intake to be blocked or obstructed by vegetation, ice, snow, or any other materials.*

⚠WARNING: *Do not use this furnace if any part has been underwater. Immediately call a qualified service agency to inspect the furnace and to replace any part of the electrical or control system which has been underwater.*

⚠WARNING: *Should overheating occur or the fuel supply fail to shut off, shut off the manual fuel supply valve to the furnace before shutting off the electrical supply.*

All installations and services must be performed by qualified service personnel.

B. COMPONENT LOCATIONS

The following diagram shows a typical furnace installation and typical position of the components referenced in these instructions.

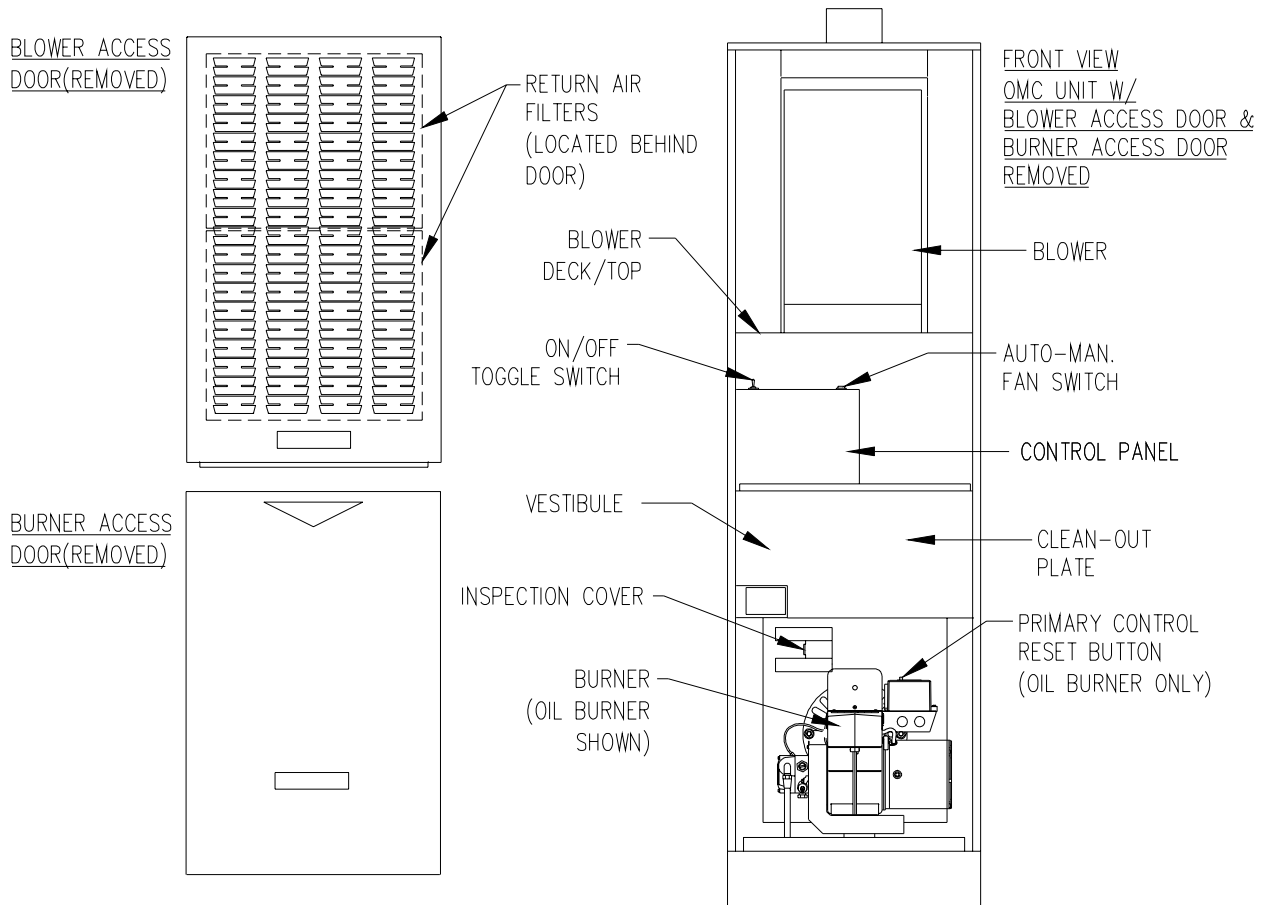

Figure 9.

C. INSPECTION AREAS

IMPORTANT: For safe operation it is the responsibility of the owner and/or user that the burner, chimney/vent pipe, heat exchanger and controls should be inspected every year by a qualified heating contractor.

1. VESTIBULE: The furnace vestibule areas or burner compartment should be inspected by opening the lower front door of the furnace and looking for signs of excessive heat such as discoloration of components, materials damaged from rust or corrosion, soot or carbon build-up.

All installations and services must be performed by qualified service personnel.

2. **EXTERIOR OF FURNACES:** The furnace exterior should be inspected for signs of excessive heat such as discoloration of materials or damage from rust or corrosion.
3. **VENT CONNECTOR:** The furnace vent pipe should be inspected for signs of rust, corrosion pitting, or holes in the pipe. Check for leakage around seams in pipe indicated by soot or condensate streaks.
4. **ROOF JACKS:** The furnace roof jack should be inspected for signs of rust or corrosion, pitting or holes, signs of excessive condensation or moisture leaking from roof jack.

D. FILTER LOCATION AND CLEANING

The air filter should be inspected each month and cleaned when dirty. Cleaning the air filter frequently may prevent airborne contaminants from going through the furnace and depositing in the furnace, duct system and interior of the building.

See Figure 9, in this section, for the location of the return air filter.

All installations and services must be performed by qualified service personnel.

APPENDIX A. REPLACEMENT PARTS LIST

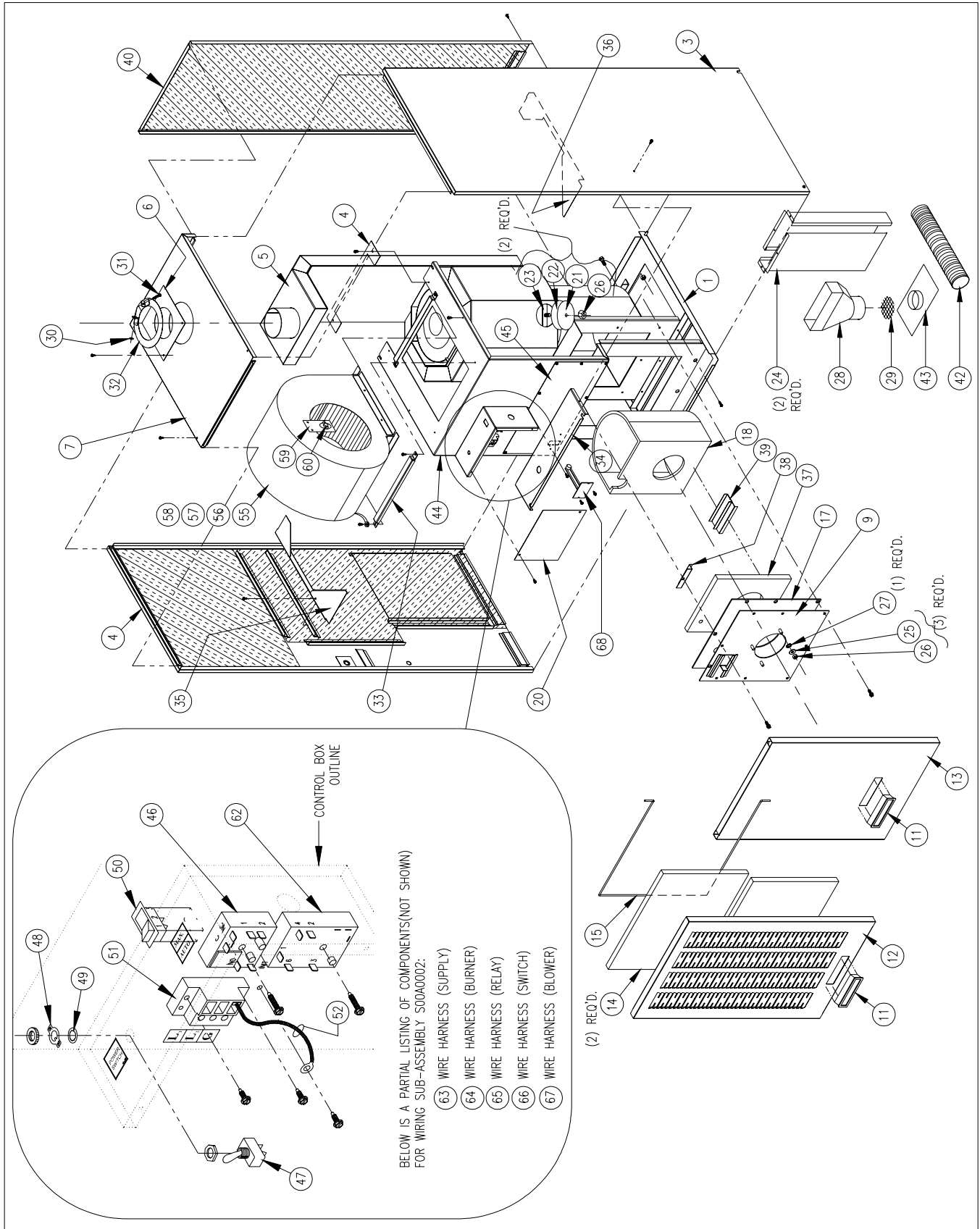

All installations and services must be performed by qualified service personnel.

ITEM	PARTS DESCRIPTION	PART NO.	QTY.	ITEM	PARTS DESCRIPTION	PART NO.	QTY.
1	BASE	20872	1	36	CASING BAFFLE, RIGHT	10868	1
2	HEAT EXCHANGER	31780	1	37	HEAT SHIELD	330170	1
3	SIDE CASING, RIGHT	20875	1	38	RETAINER	10864	1
4	SIDE CASING, LEFT	20874	1	39	CHAMBER RETAINER	10866	1
5	FLUE BLOCK OFF	10863	1	40	REAR PANEL	20862	1
6	FLUE TRIM PANEL	14112	1	41			
7	TOP CASING	10878	1	42	FLEX HOSE	10882	1
8				43	ADAPTER, COMBUSTION AIR	30881	1
9	BURNER MTG. PLATE	20860	1	44	CONTROL PANEL SUB-ASS'Y.	S00S4265	1
10				45	CLEAN-OUT PLATE	11779	1
11	DOOR PULL	320157	2	46	RELAY, TIME DELAY	350506	1
12	DOOR, BLOWER ACCESS	10879	1	47	SWITCH, TOGGLE	350136	1
13	DOOR, BURNER ACCESS	20873	1	48	PLATE, ON/OFF	350147	1
14	FILTER	370045	2	49	WASHER, SERRATED LOCK	300279	1
15	FILTER RETAINER ROD	14809	1	50	SWITCH, ROCKER	350770	1
16				51	TERMINAL BLOCK	350771	1
17	MTG. PLATE GASKET	330169	1	52	GROUND LEAD	350767	1
18	CHAMBER	380411	1	53			
19				54			
20	CONTROL BOX FRONT	11781	1	55	BLOWER SUB-ASS'Y.	S00S4108	1
21	CLEAN OUT COVER	11403	2	56	DIRECT DRIVE BLOWER	340324	1
22	CLEAN OUT COVER GASKET	330009	2	57	MOTOR MOUNTING BRKT	350629	1
23	CLEAN-OUT BAR ASSY.	21400	2	58	MOTOR	350301	1
24	INLET CHANNEL	15904	2	59	LIMIT BRACKET	14149	1
25	5/16 WASHER	300267	3	60	AUX. LIMIT SWITCH	350162	1
26	5/16-18 BRASS NUT	300102	6	61			
27	3/8 ID STARWASHER	300264	1	62	RELAY, TIME DELAY	350832	1
28	TRANSITION BOOT	320220	1	63	WIRE HARNESS (SUPPLY)	350828	1
29	SCREEN	320221	1	64	WIRE HARNESS (BURNER)	350827	1
30	10-24 SQ NUT	300121	1	65	WIRE HARNESS (RELAY)	350829	1
31	10-24x1-1/2 RD HD SCREW	300231	1	66	WIRE HARNESS (SWITCH)	350826	1
32	DRAW COLLAR	24100	1	67	WIRE HARNESS (BLOWER)	350830	1
33	BLOWER HOLD DOWN	13937	1	68	LIMIT CONTROL	350811	1
34	DIVIDER PANEL	10869	1	69			
35	CASING BAFFLE, LEFT	10867	1	70			

Free Manuals Download Website

<http://myh66.com>

<http://usermanuals.us>

<http://www.somanuals.com>

<http://www.4manuals.cc>

<http://www.manual-lib.com>

<http://www.404manual.com>

<http://www.luxmanual.com>

<http://aubethermostatmanual.com>

Golf course search by state

<http://golfingnear.com>

Email search by domain

<http://emailbydomain.com>

Auto manuals search

<http://auto.somanuals.com>

TV manuals search

<http://tv.somanuals.com>