

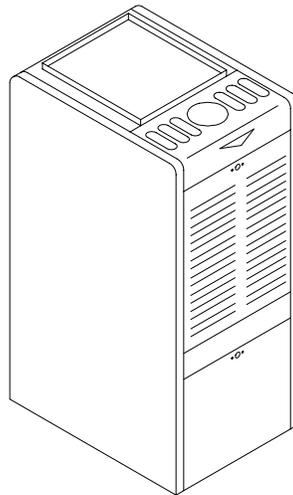

**OIL FIRED FURNACE
INSTALLATION AND OPERATION MANUAL
WITH USERS INFORMATION SECTION**

MODEL:



OH5-85DXE

⚠ WARNING: IF THE INFORMATION IN THESE INSTRUCTIONS IS NOT FOLLOWED EXACTLY, A FIRE OR EXPLOSION MAY RESULT CAUSING PROPERTY DAMAGE, PERSONAL INJURY, OR LOSS OF LIFE.

DO NOT STORE OR USE GASOLINE OR OTHER FLAMMABLE VAPORS AND LIQUIDS IN THE VICINITY OF THIS OR ANY OTHER APPLIANCE.

⚠ WARNING: IMPROPER INSTALLATION, ADJUSTMENT, ALTERATION, SERVICE, OR MAINTENANCE CAN CAUSE INJURY OR PROPERTY DAMAGE. REFER TO THIS MANUAL. FOR ASSISTANCE OR ADDITIONAL INFORMATION CONSULT A QUALIFIED INSTALLER, OR SERVICE AGENCY.

PLEASE READ THESE INSTRUCTIONS PRIOR TO INSTALLATION, INITIAL FIRING, AND BEFORE PERFORMING ANY SERVICE OR MAINTENANCE. THESE INSTRUCTIONS MUST BE LEFT WITH THE USER AND SHOULD BE RETAINED FOR FUTURE REFERENCE BY QUALIFIED SERVICE PERSONNEL.

THERMO PRODUCTS, LLC.
PO BOX 217
NORTH JUDSON, IN 46366
PHONE: (574) 896-2133



MO-444
ECN 4673AMA

MADE IN USA

I. SAFETY SECTION

This page contains various warnings and cautions found throughout the Oil Furnace Manual. Please read and comply with the statements below.

△WARNING AND CAUTIONS:

△WARNING: This furnace is not to be used as a construction heater. See Page 1.

△ CAUTION MUST BE TAKEN NOT TO EXCEED 90° ROTATION (OF THE FLUE ELBOW) COUNTERCLOCKWISE OR RIGHT FROM THE VERTICAL POSITION.

See Page 2.

△WARNING: The predetermined limit locations on all of the Thermo Pride oil fired furnaces have been tested and approved by Thermo Products, LLC. Any attempt to relocate these safety controls or replace these safety controls with a control that is not approved, or is incompatible, may result in personal injury, substantial property damage or death. See Page 4.

△WARNING: THE HEAT EXCHANGER MUST BE CLEANED BY A QUALIFIED SERVICE PERSON. See Page 7.

△CAUTION: DO NOT ATTEMPT TO MAKE REPAIRS YOURSELF! See Page 8.

△WARNING: The area around the furnace should be kept free and clear of combustible liquids and material, especially papers and rags. See Page 8.

△WARNING: NEVER burn garbage or refuse in your furnace. Never try to ignite oil by tossing burning papers or other material into your furnace. See Page 8.

△WARNING: Thermo Products oil furnaces are designed to burn No. 1 or No. 2 distillate fuel oil. NEVER USE GASOLINE OR A MIXTURE OF OIL AND GASOLINE. See Page 8.

△CAUTION: DO NOT ATTEMPT TO START THE BURNER WHEN:

1. Excess oil has accumulated,
2. The furnace is full of vapors
3. The combustion chamber is very hot.

IF ONE OR MORE OF THESE CONDITIONS EXIST, CONTACT A QUALIFIED SERVICE PERSON. See Page 8.

All installations and services must be performed by qualified service personnel.

TABLE OF CONTENTS

<u>SECTION</u>	<u>BEGINNING PAGE</u>
I. SAFETY SECTION	i
II. GENERAL INSTRUCTIONS	1
A. VENTING	2
B. DRAFT REGULATORS	2
C. DUCT WORK/AIR CONDITIONING	3
D. FILTERS MOUNTED EXTERNAL TO FURNACE	3
E. LIMIT POSITION AND LOCATION	5
F. BURNER INSTALLATION	5
G. BURNER SPECIFICATIONS AND APPLICATIONS	7
H. HEAT EXCHANGER CLEANING INSTRUCTIONS	8
III. USERS INFORMATION SECTION	9
A. OIL SUPPLY	9
B. COMBUSTION AIR SUPPLY	9
C. INSPECTION AREAS	9
D. STARTING THE BURNER	9
E. FILTER CLEANING AND LOCATIONS	10
APPENDIX – A REPLACEMENT PARTS LIST	12
APPENDIX – B WIRING DIAGRAMS	13

All installations and services must be performed by qualified service personnel.

II. GENERAL INSTRUCTIONS - READ BEFORE START OF INSTALLATION

1. The heating output capacity of the furnace proposed for installation should be based on a heat loss calculation made according to the manuals provided by the Air Conditioning Contractors of America (ACCA) or the American Society of Heating, Refrigeration and Air Conditioning Engineers, Inc. (ASHRAE).
2. All local codes and/or regulations take precedence over the instructions in this manual and should be followed accordingly. In the absence of local codes, installation must conform with these instructions and regulations of the National Fire Protection Association, and to the provisions of the National Electrical Code (ANSI/NFPA 70-1999 or latest edition).
3. The installed furnace must be level and positioned in a central location with respect to outlet registers. It should be located near the chimney to minimize any horizontal run of flue pipe, which may be required.
4. A furnace installed in a residential garage must be installed so the burner and ignition source are located higher than 18 inches above the floor, unless the required combustion air is taken from the exterior of the garage. Also, the furnace must be located or protected to avoid physical damage by vehicles.

⚠WARNING: This furnace is not to be used as a construction heater.

5. Listed below are definitions of "COMBUSTIBLE MATERIAL" and "NON-COMBUSTIBLE MATERIAL."

COMBUSTIBLE MATERIAL:

Material made of or surfaced with wood, compressed paper, plant fibers, plastics, or other material that will ignite and burn, whether flame resistant or not.

NON-COMBUSTIBLE MATERIAL:

Material that is not capable of being ignited and burned. Such materials consist entirely of, or a combination of, steel, iron, brick, tile, concrete, slate, or glass.

MINIMUM CLEARANCES TO COMBUSTIBLE MATERIALS

TYPE OF UNIT	MODEL NO.¹	FROM SIDES OF FURNACE	FRONT	TOP & SIDES OF PLENUM	FROM THE FLUE/VENT	REAR
HIGHBOY	OH5-85DXE***	1	24	1	6	1

The minimum clearances listed in the preceding table are for fire protection. Clearance for servicing the front of the furnace and the rear of the lowboy models should be at least 24 inches. A clearance of 24 inches is recommended for passage to all points on the furnace requiring service access.

The OH5-85DXE*** furnaces may be installed on combustible flooring.

NOTE: The OH5-85DXE*** furnace is approved for closet installation. If the OH5-85DXE*** is installed in a closet, it requires two openings in the closet door for combustion air, each having a minimum area of 162 sq. inches. This free area for the OH5-85DXE*** intentionally exceeds the recommended minimum free area of 2 square inches per 1000 BTUH of input rate.

NOTE: When power venting a Thermo Pride oil fired furnace with a power venting system other than the system supplied by Thermo Pride, a fiber chamber and an isolated combustion air kit (PVB or Beckett boot) is to be used with the other manufacturers power venting system.

All installations and services must be performed by qualified service personnel.

A. VENTING:

NOTE: On the OH5-85DXE*** it is possible to rotate the flue elbow (which is factory installed for vertical discharge) 90° counterclockwise from the vertical position to adapt to various venting systems.

⚠ CAUTION MUST BE TAKEN NOT TO EXCEED 90° ROTATION (OF THE FLUE ELBOW) COUNTERCLOCKWISE OR RIGHT FROM THE VERTICAL POSITION.

ROTATION OF FRONT FLUE ELBOW

When an installation requires that the flue exit out the left hand side casing on a front flue unit, remove screw securing the 90 deg. elbow and rotate it 90° **counterclockwise**. Then, by following the dimensions listed below, locate the center point for the exit of the flue. Once the center has been located, use a scribe to mark the hole size. Cut hole and extend flue through side casing.

A trim collar may be ordered from Thermo Products to hide the gap around the flue pipe. This trim collar, however, is not required for operation. Trim collar/gasket part numbers(s) 14121 / 330073.

TABLE 1: Suggested size and position of flue pipe opening on left hand side of casing.

UNIT	DIA. HOLE	“X” DIM.	“Y” DIM.	FLUE DIA.	TRIM COLLAR/ GASKET PART #
OH5-85DXE	6-1/2”	4-3/4”	33-1/16”	6”	14131/330005

* FRONT FLUE MODELS ONLY

“X” DIMENSION IS MEASURED FROM SEPARATOR PANEL.

“Y” DIMENSION IS MEASURED FROM THE BLOWER PAN ON “H” MODELS AND FROM THE BASE ON “L” AND “C” MODELS.

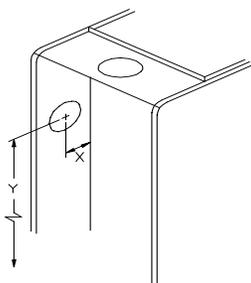

Fig 1: Recommended location for drilling hole to connect vent pipe to the furnace through the left hand side casing.

NOTE: ROTATION OF FLUE PIPE IS ONLY ALLOWED FOR LEFT HAND SIDE VENTING APPLICATIONS.

The OH5-85DXE*** may be vented through a standard correctly sized chimney.

B. DRAFT REGULATORS:

A draft regulator is supplied with the furnace and should be installed according to the regulator manufacturers recommendations. With the burner operating, use a draft gauge to adjust the regulator to the proper setting. (refer to the instructions enclosed with draft regulator to adjust to the proper setting). When the burner air supply and draft are properly adjusted, the overfire draft should be a negative (-).01" to (-).02" WC ¹, as measured at the 5/16" overfire air tap (See Fig. 8). This tap is provided in the upper burner mounting plate. To measure the flue draft, punch a small hole in the vent connector pipe as close to the furnace as possible and always before the draft regulator.

All installations and services must be performed by qualified service personnel.

C. DUCT WORK/AIR CONDITIONING:

If the furnace is used in connection with summer air conditioning (cooling), the furnace should be installed parallel with or on the upstream side of the evaporator coil to avoid condensation in the furnace heat exchanger. If the cooling unit is installed with a parallel flow arrangement, dampers or other means used to control flow of air should be provided to prevent chilled air from entering the furnace. If such a damper is manually operated, it must be equipped with a means to prevent operation of either unit, unless the damper is in the full heat or cool position.

The duct system should again follow the current design standard of Air Conditioning Contractors of America (ACCA) or ASHRAE Fundamentals volume. The most common location for the A-shaped coil (A style) is shown in Fig. 2.

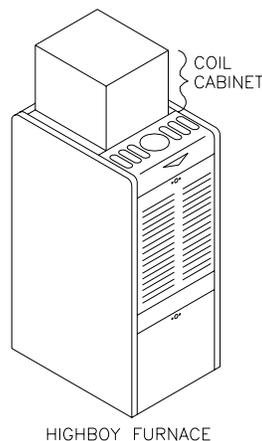

Fig 2: Acceptable locations for the air conditioner evaporator coil.

NOTICE: The minimum coil pan clearance for a sectional or drum type heat exchanger is three inches unless specified otherwise by the individual coil manufacturer.

D. FILTERS MOUNTED EXTERNAL TO FURNACE

On **highboy** furnaces, it is necessary to cut the return air opening in the side or rear casing, depending upon the needs of the specific installation.

The filter rack provided with the furnace, refer to Fig. 5, will serve as a template to scribe a mark for the return air opening on the casing. Place the filter rack on a side casing approximately one inch up from the bottom of the furnace and centered from side to side. Place the securing flange against the casing when locating the return air opening. For your convenience, (4) locator knock-outs have been placed at the proper locations on both the left and right side casings.

PLEASE NOTE: While scribing the return air opening, the filter rack can be held in position by tape or similar temporary means.

Position the open end of the filter rack so as to provide access for filter replacement. Once the filter rack is positioned correctly, scribe a line along the inside of the securing flange on three of the sides. To scribe a line on the fourth side (the open end), use the open end support as a guide.

Remove the filter rack and cut the return air opening in the casing. Now the filter rack can be anchored to the furnace with screws or pop-rivets through the securing flange of the filter rack.

All installations and services must be performed by qualified service personnel.

Connect the return air plenum to the filter rack and slide the filter into place. Dimensions for adapting the return air plenum to the filter rack are provided (See Fig. 5).

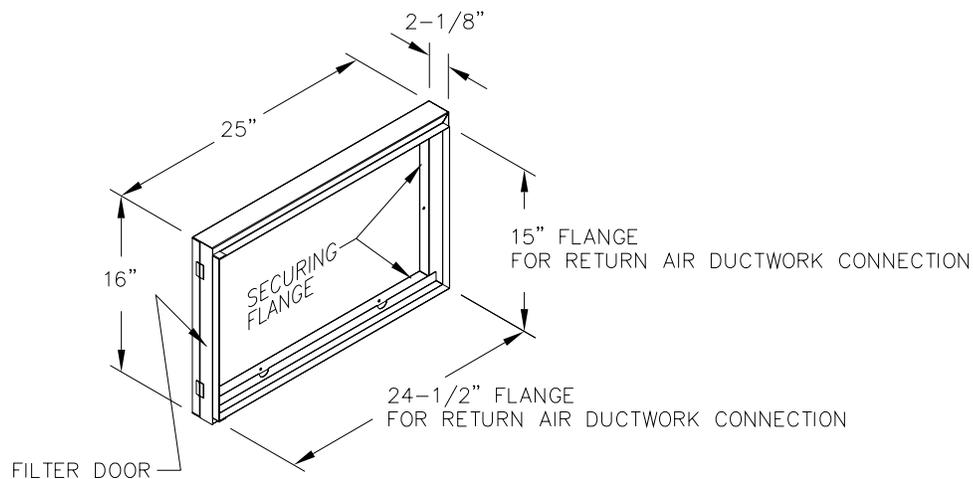

Fig. 5: A typical filter rack and dimensions for the OH5-85DXE* furnace.**

PLEASE NOTE: While scribing the return air opening, the filter rack can be held in position by tape or similar temporary means.

Position the open end of the filter rack so as to provide access for filter replacement. Once the filter rack is positioned correctly, scribe a line along the inside of the securing flange on three of the sides. To scribe a line on the fourth side (the open end), use the open end support as a guide.

Remove the filter rack and cut the return air opening in the casing. Now the filter rack can be anchored to the furnace with screws or pop-rivets through the securing flange of the filter rack.

⚠WARNING: When cutting openings in the casing **DO NOT CUT ANY SUPPORTING CLIPS OR ANGLES.** Cut as close to the scribed line as possible, but do not cut the base clip or blower pan support angle. (See Fig. 6).

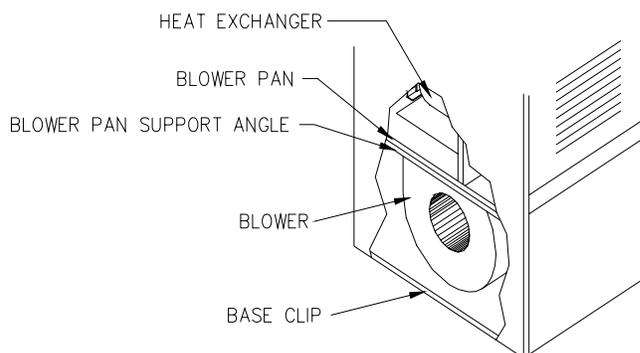

Fig. 6: Cutaway view of fan section of a typical highboy furnace.

Connect the return air plenum to the filter rack and slide the filter into place. Dimensions for adapting the return air plenum to the filter rack are provided on the bottom of the previous page.

All installations and services must be performed by qualified service personnel.

E. LIMIT POSITION AND LOCATION

⚠WARNING: The predetermined limit locations on all of the Thermo Pride oil fired furnaces have been tested and approved by Thermo Products, LLC. Any attempt to relocate these safety controls or replace these safety controls with a control that is not approved, or is incompatible, may result in personal injury, substantial property damage or death.

The unit listed in the table below must have the fan and limit control installed at the time of unit installation.

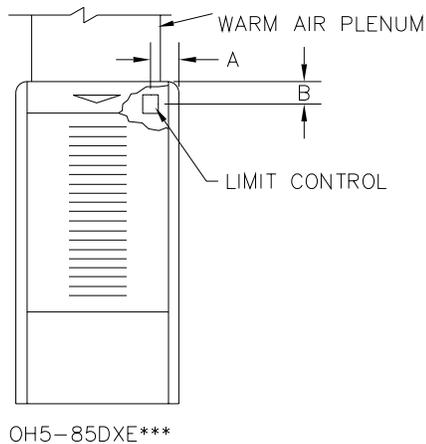

TABLE 2: Installation location of the fan and limit control for each furnace

DIM.	A	B
MODEL		
OH5-85DXE***	3-1/2"	1-3/8"

Fig. 7: Limit location for OH5-85DXE***

F. BURNER INSTALLATION:

The oil burner will mount on three stud mounting bolts on the lower mounting plate covering the opening in the front of the heat exchanger. The end of the burner tube should be inserted no further than 1/4 inch back from the inside surface of the combustion chamber. A distance further than 1/4 inch back from the inside chamber wall may cause impingement and sooting.

NOTE: OVERFIRE AIR TAP MAY BE LOCATED ON EITHER SIDE OF FLAME INSPECTION COVER. (See Fig. 8).

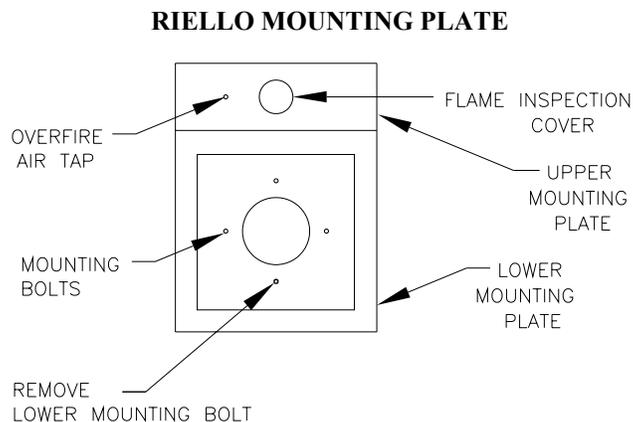

Fig. 8: Typical location of the overfire air tap

All installations and services must be performed by qualified service personnel.

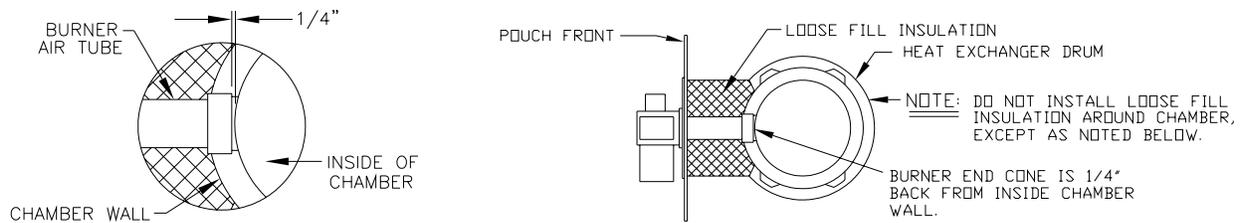

Fig. 9: (Top view) Burner insertion illustration

When mounting the burner, the upper mounting plate (Fig. 8) must be removed to provide access to the area in front of the combustion chamber. The combustion chamber can then be moved forward or backward slightly to allow for adjustment in positioning the burner tube. Do not allow the burner tube or end cone to physically touch or protrude into the chamber, as excess heat transfer could result in destruction of the tube, end cone or both. The burner tube/end cone is properly positioned, when the end is $\frac{1}{4}$ inch back from the inside surface of the combustion chamber wall.

NOTE: The loose-fill insulation that is included in a brown paper bag should be lightly placed around the burner tube between the front of the combustion chamber and the burner mounting plate. (DO NOT PACK THE INSULATION DOWN). The loose-fill insulation should be placed in such a fashion that the surface of the insulation is sloped from the top of the combustion chamber to the top of the lower mounting plate. The purpose of the loose insulation is to help protect the burner tube, mounting plates and vestibule area from excessive temperatures.

NOTE: Do not place loose insulation around chamber sides and back .

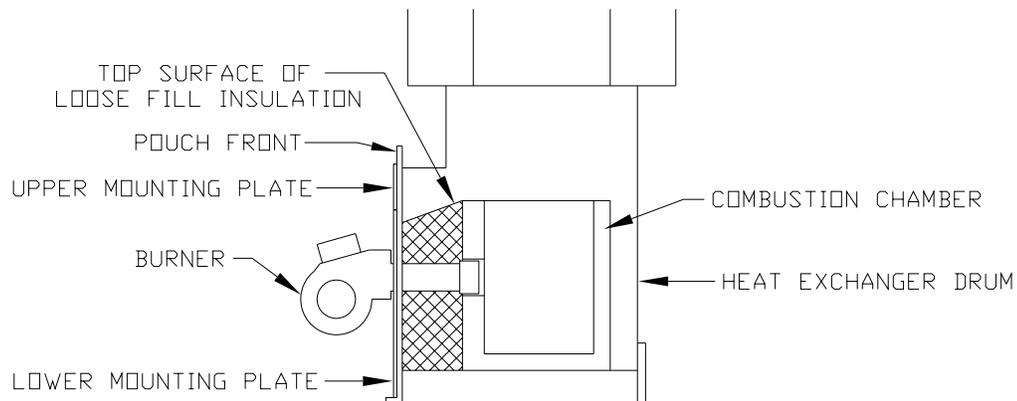

Fig. 10: (Side view) Burner insertion illustration

All installations and services must be performed by qualified service personnel.

G. BURNER SPECIFICATIONS AND APPLICATIONS

RIELLO BURNER APPLICATION CHART

MODEL PART	OH5 2 STAGE
MTG. PLATE PART NO.	35750
MTG. PLATE GASKET PART NO.	330088
**NOZZLE SIZE	.70 X 45° W
NOZZLE PART NO.	380702
OIL PUMP PRESSURE	130 LOW 170 HIGH
BURNER	G-51
BURNER PART NO.	380695

* INSULATOR S = SLEEVE OR N = NONE

THE NOZZLE SIZE GIVES THE NOMINAL FLOWRATE, IN GPH, FOLLOWED BY THE SPRAY ANGLE, IN DEGREE'S, AND THE SPRAY PATTERN, EITHER "H" FOR HOLLOW CONE OR "S" FOR SOLID CONE. FOR EXAMPLE, A NOZZLE RATED AT 0.65 GPH @ 100 PSIG THAT PROVIDES AN 80° SPRAY ANGLE AND A HOLLOW SPRAY PATTERN WOULD BE ABBREVIATED IN THE TABLE AS "0.65 X 80°H".

** NOTE: The reason the Riello burner nozzle sizes are smaller than the standard Thermo Pride burner nozzles is that pre-set pump pressures are higher, therefore achieving the same firing rate with a smaller nozzle.

For more specific burner information, specifications or service information, reference the training manual enclosed with each Riello burner or contact:

Riello Corporation of America,
5 Pond Park Road
Hingham, Massachusetts 02043
(617) 749-8292

2 STAGE FIRING RATES			
	NOZZLE SIZE Riello	INPUT RATE* (BTU/HR)	EFFECTIVE** HEATING CAPACITY
OH5-85DXE***			
HIGH FIRE		106,250/170psi	85,000
LOW FIRE	.70 X 45° W	85,000/130psi	74,000

* Based on #2 domestic heating fuel oil having heating value of 140,000 BTU per gallon.

** Based on thermal efficiency of 84%-85%.

All installations and services must be performed by qualified service personnel.

H. HEAT EXCHANGER CLEANING INSTRUCTIONS:

⚠WARNING: THE HEAT EXCHANGER MUST BE CLEANED BY A QUALIFIED SERVICE PERSON.

It is important to inspect and clean the heat exchanger once a year, or as necessary, to remove any build-up of soot. A layer of soot on the inside of the heat exchanger will act as an insulator and reduce heat transfer, resulting in less efficiency.

To clean the heat exchanger, first turn off all power to the unit. Next, remove the access panel (see below and beginning of following page) immediately above the burner to gain entry to the clean-out covers, refer to figure 15. **This panel is identified with a label.** Remove clean-out covers, the vent connector pipe to the chimney, the burner, and the burner mounting plates. When removing the clean-out covers, special care must be taken not to damage the gaskets. Should the gaskets separate, crack, break, or be unsuitable for reuse, the gasket must be replaced before reattaching the clean-out covers.

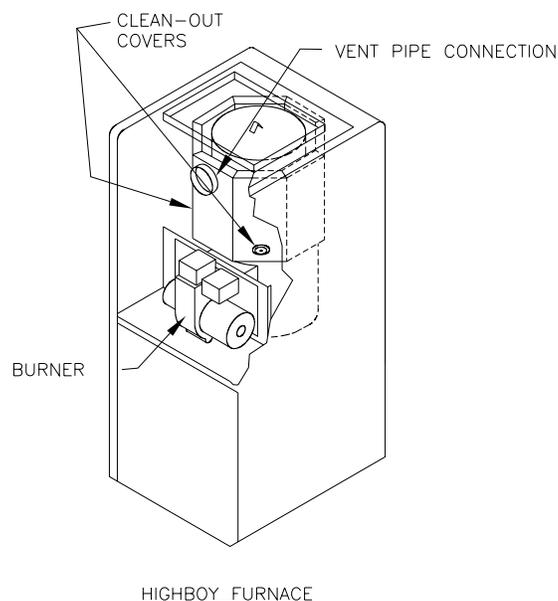

Fig. 15: (Side view) Burner insertion illustration

With access to the inside of the heat exchanger through the burner area, clean-out openings, and vent pipe connection, it is possible to use a long, flexible wire brush and an industrial type vacuum cleaner to remove any soot build-up. **NOTE:** A one inch (outside diameter) vacuum cleaner hose will fit into the radiator.

To vacuum and brush the outer radiator of the heat exchanger, go through the clean-out openings in both directions, as shown in figure 16, below.

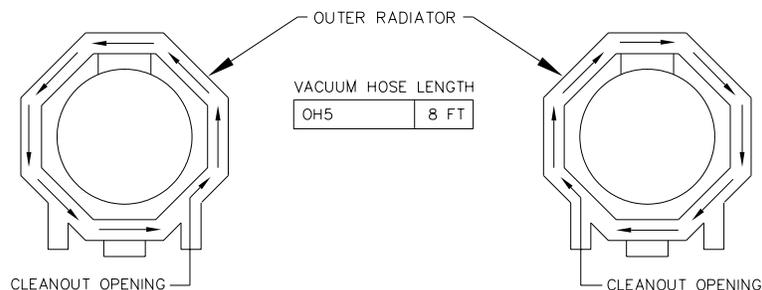

Fig. 16: Recommended method and device for cleaning inside of heat exchanger.

All installations and services must be performed by qualified service personnel.

Reassemble the furnace to its original construction. Remount the burner being certain that the air tube is properly inserted into the chamber opening (see section E). If heavy soot deposits were found in the heat exchanger, this may indicate the burner is out of adjustment.

III. USERS INFORMATION SECTION

A. OIL SUPPLY: Do not allow the fuel tank to run completely empty. During the summer, keep the tank full to prevent condensation of moisture on the inside surface of the tank. If the fuel tank runs completely dry, it may be necessary to purge the lines of trapped air. Contact a qualified technician to bleed the lines and restart the burner.

OIL SUPPLY VALVE: Turn the oil supply valve off if the burner is shut down for an extended period of time.

B. COMBUSTION AIR SUPPLY: The burner requires a generous amount of clean combustion air to operate safely. Lack of adequate combustion air can result in erratic operation of the burner, noisy combustion, or fuel odors in the air. NEVER BLOCK THE FURNACE FROM THE SUPPLY OF COMBUSTION AIR. If there is an exhaust fan, dryer or return air grill in the furnace room, there should be increased concern and additional efforts may be required to provide adequate combustion oil to the furnace at all times.

0-+

C. INSPECTION AREAS

VESTIBULE: The furnace vestibule area or burner compartment should be inspected by removing the front door of the furnace and looking for signs of excessive heat such as discoloration of components materials damage, from rust or corrosion, soot or carbon build-up.

EXTERIOR OF FURNACE: The furnace exterior should be inspected for signs of excessive heat such as discoloration of materials and damage from rust or corrosion.

FLUE PIPE, VENT PIPE OR CONNECTOR: The furnace vent pipe should be inspected for signs of rust, corrosion pitting or holes in pipe, and leakage around seams in pipe, indicated by soot or condensate streaks.

CHIMNEY OR VENTING SYSTEM: The furnace venting system should be inspected for signs of rust, corrosion pitting or holes, and signs of condensation or moisture leakage from the venting system.

If any of the above symptoms are evident, call a qualified heating contractor for assistance.

⚠CAUTION: DO NOT ATTEMPT TO MAKE REPAIRS YOURSELF!

⚠WARNING: The area around the furnace should be kept free and clear of combustible liquids and material, especially papers and rags.

⚠WARNING: NEVER burn garbage or refuse in your furnace. Never try to ignite oil by tossing burning papers or other material into your furnace.

⚠WARNING: Thermo Pride oil furnaces are designed to burn No. 1 or No. 2 distillate fuel oil. NEVER USE GASOLINE OR A MIXTURE OF OIL AND GASOLINE.

⚠CAUTION: DO NOT ATTEMPT TO START THE BURNER WHEN:

- 1. Excess oil has accumulated,**
- 2. The furnace is full of vapors**
- 3. The combustion chamber is very hot.**

IF ONE OR MORE OF THESE CONDITIONS EXIST, CONTACT A QUALIFIED SERVICE PERSON.

D. STARTING THE BURNER:

1. Turn the main service switch to "OFF" position.
2. Set thermostat substantially above room temperature.
3. Open shut-off valves in oil supply line to burner.

All installations and services must be performed by qualified service personnel.

4. Turn service switch to furnace "ON". If burner starts and runs, but stops again on lockout, it may be necessary to bleed the lines or make burner combustion air adjustments. Contact a qualified service person to adjust and start burner.

E. FILTER CLEANING AND LOCATION:

The air filters should be inspected each month and cleaned when dirty. Cleaning the air filters frequently may reduce airborne contaminants from entering the furnace and depositing in the furnace, duct system and home.

⚠WARNING: To avoid injury from moving parts, hot surfaces, or electrical shock, shut off the power to the furnace before removing any furnace access doors to service the air filters.

The filter rack will be located between the return air plenum and the return air opening on the side of the furnace, refer to figure 18. Slide the dirty filter out, clean it with a mild soap and water solution. Make sure filter is thoroughly dry before replacing.

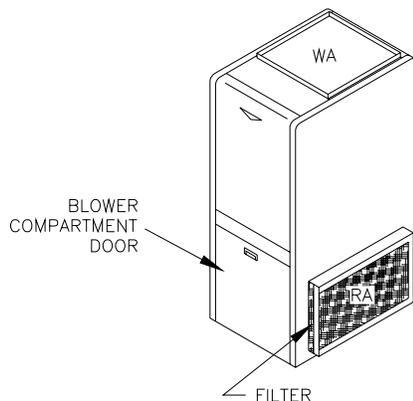

Fig. 18: Location of the air filter on the typical highboy furnace.

All installations and services must be performed by qualified service personnel.

COMBUSTION AND EFFICIENCY TESTING FOR THERMO PRIDE OIL FIRED CENTRAL FURNACES.

Complete this form for each Thermo Pride furnace installed. Read instruction manual carefully before making tests. Retain this form with furnace.

CUSTOMER	NAME				
	ADDRESS				
	CITY, STATE				
HEATING SYSTEM	BURNER MODEL NO.	BLAST TUBE LGTH. INS.	AIR SHUTTER OPENING % OF MAX. (EST)		
	COMBUSTION CHAMBER		CONDITION	MATERIAL	FURNACE MODEL
	TYPE OF VENTING SYSTEM				
	<input type="checkbox"/> MASONRY CHIMNEY	<input type="checkbox"/> METAL CHIMNEY	<input type="checkbox"/> METAL CHIMNEY W/METAL LINER	<input type="checkbox"/> SIDEWALL POWER VENTER	<input type="checkbox"/> MASONRY CHIMNEY W/INDUCER
	<input type="checkbox"/> METAL CHIMNEY W/INDUCER				
FUEL LINE FILTER	DRAFT CONTROL		FURNACE SERIAL NUMBER		
COMBUSTION TESTS (Operate burner at least 10 minutes before starting tests.)		INITIAL INSTALLATION	SERVICE	SERVICE	SERVICE
	CO2 in stack pipe				
	Draft Over-fire				
	Draft in stack pipe				
	Smoke number				
	Gross stack temp.				
	Furnace room temp.				
	Net stack temp. (Gross stack minus furnace room temp.)				
	Efficiency				
	Nozzle size and spray				
	Oil pump pressure				
	Operation of Controls				
	Burner Safety Controls				
	Check for oil leaks				
	Tests taken by				
	Date				
	NOTES:				
	INSTALLER NAME & ADDRESS				

All installations and services must be performed by qualified service personnel.

APPENDIX-B Wiring Diagram

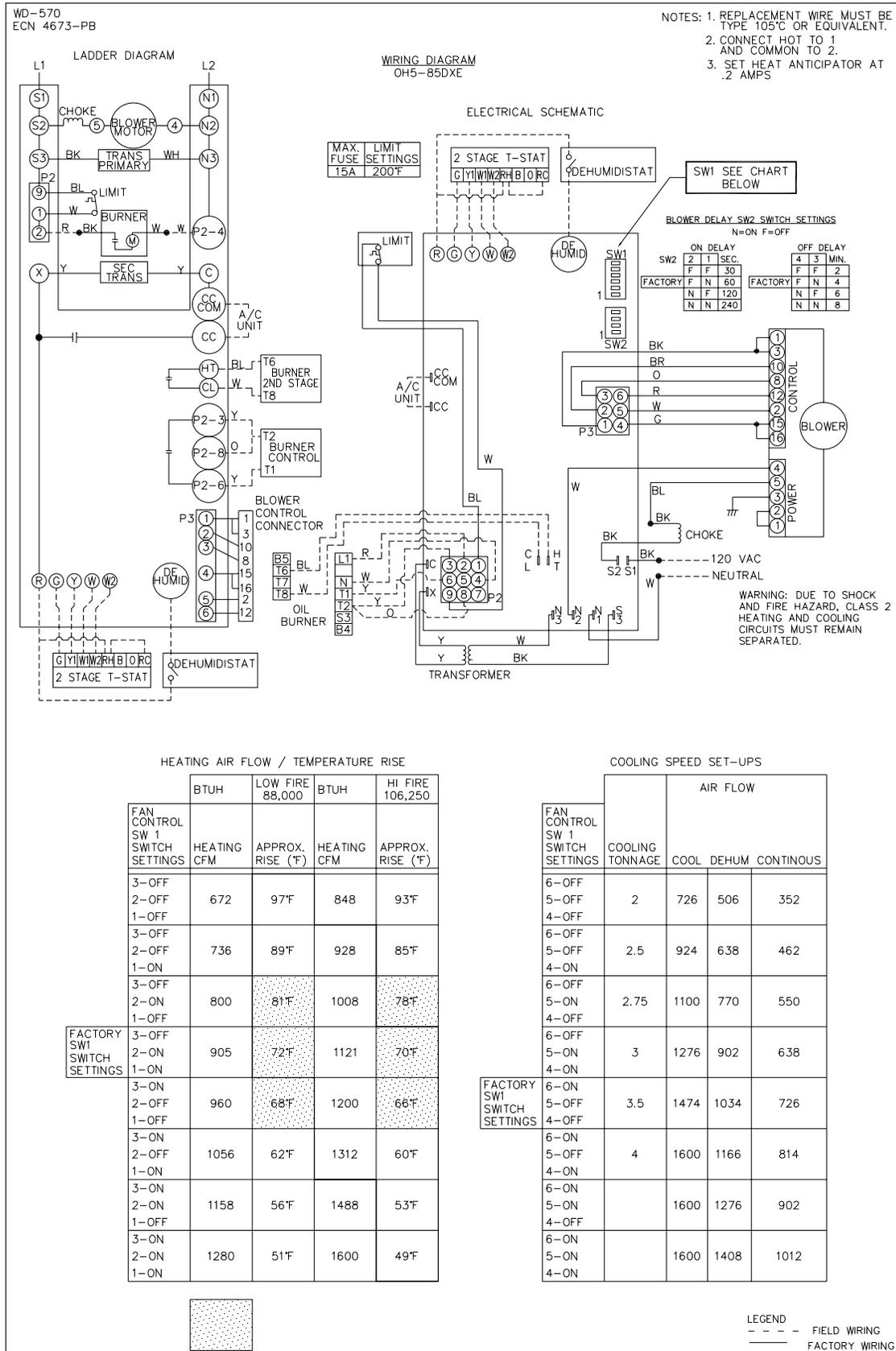

Thermo Products, LLC. "PEACE OF MIND" Warranty (Limited)

Five Year Parts and Transportation Lifetime on Heat Exchanger

Thermo Products, LLC., an Indiana corporation, hereby warrants the Thermo Pride oil and gas fired warm air furnaces manufactured by it to be free from defects in material and workmanship. The warranty is extended to the original owner(s) whose name(s) appear on this certificate, on the Warranty Registration Card returned to Thermo Products, LLC. and also to any subsequent owner(s).

1ST-5TH YEAR: During the first 60 months after installation, all parts of the furnace are warranted with the exception of maintenance items which require periodic replacement (i.e. filters, belts, nozzles, electrodes, etc.). The owner may arrange with the original installing dealer or any other qualified dealer of the owner's choice to replace a defective part. Any labor costs involved in furnace diagnosis, service or the removal and replacement of a defective part are the responsibility of the owner. Warranted replacement parts will be shipped by prepaid freight with instructions to the dealer on disposition of the defective part. Beyond the fifth year, only the furnace heat exchanger is covered.

BEYOND THE 5TH YEAR: The heat exchanger carries a Limited Lifetime Warranty. If at any time during the warranty period the heat exchanger becomes defective, Thermo Products, LLC. will provide at its option either a replacement heat exchanger or the necessary repair parts on a no charge basis. Any labor costs involved in the diagnosis, repair or the removal and replacement of a heat exchanger are the responsibility of the owner. The owner may arrange with any qualified HVAC dealer for the necessary labor. Beyond the fifth year, any transportation costs associated with the replacement of the complete heat exchanger or the repair parts are the responsibility of the owner. If Thermo Products, LLC. requests the return of the defective heat exchanger after the fifth year, it must be returned by prepaid transportation at the expense of the owner.

THE CONDITIONS OF THIS WARRANTY ARE:

- A. The owner must complete and return the WARRANTY REGISTRATION CARD within ninety (90) days of installation to activate Warranty Coverage. If the completed WARRANTY REGISTRATION CARD is received after the ninety (90) day period, the date of installation will be considered the ninetieth (90th) day after the date the unit was sold to the dealer.
 - B. The unit must be operated within its rated capacity as indicated on the rating label and fired with the fuel for which it was designed.
 - C. The unit must operate with a duct system designed in accordance with ACCA (Air Conditioning Contractors of America) Manual D (current edition) recommendations and a vent system designed in accordance with current industry venting code(s).
 - D. The unit must be installed, set up and maintained in accordance with local and state codes and/or THERMO PRODUCTS, LLC. installation and operation instructions.
 - E. The unit must not be installed in any structure where a corrosive atmosphere exists such as may be found in dry cleaning establishments, laundromats, beauty parlors or industrial buildings without first contacting Thermo Products, LLC. concerning proper application. A corrosive atmosphere is one contaminated by chlorine or fluorine, or any of the halogen group which when entering the combustion area of a furnace cause rapid deterioration of the inner surfaces ultimately leading to heat exchanger failure.
 - F. Limit controls which are supplied with the unit and having pre-set maximums must not be modified, altered, or by-passed.
 - G. The unit must not be modified and/or operated in any manner other than its design configuration.
 - H. No air conditioning or heat pump coil may be installed on the return air side of the furnace.
 - I. The unit must remain at its original installation address.
 - J. Thermo Products, LLC. shall not be responsible for any failure due to water damage and/or acts of God.
- FAILURE TO COMPLY WITH ANY OF ABOVE CONDITIONS WILL VOID ANY AND ALL WARRANTIES LISTED ABOVE.**

THIS WARRANTY EXPRESSLY SUPERSEDES ALL OTHER WARRANTIES AND OBLIGATIONS OF THERMO PRODUCTS, LLC. NO PERSON HAS AUTHORITY TO ALTER OR MODIFY THE TERMS OF THIS WARRANTY IN ANY MANNER. THERMO PRODUCTS, LLC. ASSUMES NO LIABILITY FOR CONSEQUENT DAMAGE OF ANY KIND, AND THE PURCHASER BY ACCEPTANCE OF THIS EQUIPMENT ASSUMES ALL LIABILITY FOR THE CONSEQUENCE OF ITS USE OR MISUSE BY THE PURCHASER, HIS EMPLOYEE, OR OTHERS.

Dealers Name _____
Address _____
City, State, Zip _____
Date of Installation _____
Model No. _____ Serial No. _____
Owner(s) _____
Installation Address _____
City, State, Zip _____

Thermo Products, LLC.

P. O. Box 217
North Judson, Indiana 46366
PH-574-896-2133

Free Manuals Download Website

<http://myh66.com>

<http://usermanuals.us>

<http://www.somanuals.com>

<http://www.4manuals.cc>

<http://www.manual-lib.com>

<http://www.404manual.com>

<http://www.luxmanual.com>

<http://aubethermostatmanual.com>

Golf course search by state

<http://golfingnear.com>

Email search by domain

<http://emailbydomain.com>

Auto manuals search

<http://auto.somanuals.com>

TV manuals search

<http://tv.somanuals.com>