

TEC

TEC Bar Code Printer

B-30 SERIES

Owner's Manual

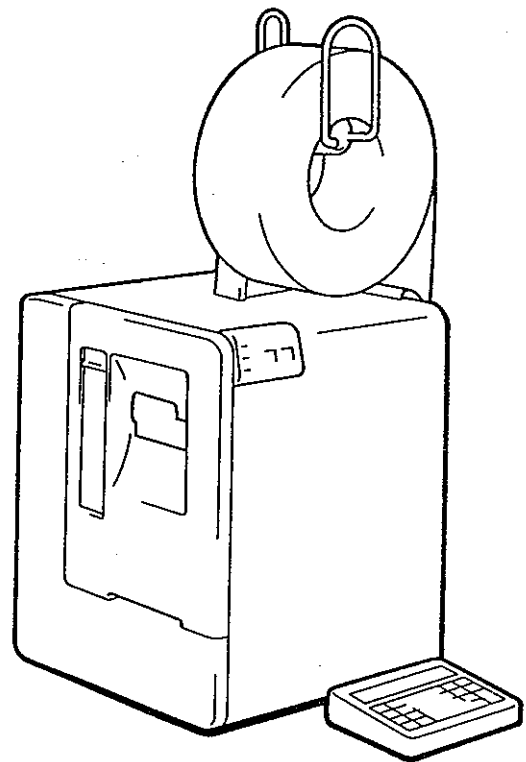

TOSHIBA TEC CORPORATION

WARNING

This equipment generates, uses, and can radiate radio frequency energy and if not installed and used in accordance with the instruction manual, may cause interference to radio communications. It has been tested and found to comply with the limits for a Class A computing device pursuant to Subpart J of Part 15 of FCC Rules, which are designed to provide reasonable protection against such interference when operated in a commercial environment. Operation of this equipment in a residential area is likely to cause interference in which case the user at his own expense will be required to take whatever measures may be required to correct the interference.

(for U.S.A. only)

WARNING

"THIS DIGITAL APPARATUS DOES NOT EXCEED THE CLASS A LIMITS FOR RADIO NOISE EMISSIONS FROM DIGITAL APPARATUS SET OUT IN THE RADIO INTERFERENCE REGULATIONS OF THE CANADIAN DEPARTMENT OF COMMUNICATIONS."

"LE PRÉSENT APPAREIL NUMÉRIQUE N'EMET PAS DE BRUITS RADIOÉLECTRIQUES DÉPASSANT LES LIMITES APPLICABLES AUX APPAREILS NUMÉRIQUES DE LA CLASSE A PRESCRITES DANS LE RÉGLEMENT SUR LE BROUILLAGE RADIOÉLECTRIQUE ÉDICTÉ PAR LE MINISTÈRE DES COMMUNICATIONS DU CANADA."

(for CANADA only)

INTRODUCTION

Thank you for choosing the TEC Bar Code Printer B-30-AS3. The B-30-AS3 has been developed for issuing various kinds of bar codes, and can be connected to a personal computer, etc., via a TEC interface. The B-30-AS3 adopts a state of the art thermal printer so that it produces less noise and more clearly printed characters. You can easily select either the thermal transfer or thermal direct printing method.

This manual contains information about the general set-up and maintenance of the B-30-AS3 printer, and should be read carefully to obtain maximum performance from your printer. Since ample consideration has been given to safety, there is no danger of damaging the printer by erroneous operation.

Should you have any questions concerning the printer, please refer to this manual. Be sure to keep this manual for future reference.

PRECAUTIONS

1. Clean the cover by wiping with a dry cloth or a cloth soaked with detergent and thoroughly wrung out. NEVER USE THINNER OR OTHER VOLATILE SOLVENT for cleaning.
2. DO NOT POUR WATER directly on the printer.
3. When in use, avoid locations subject to vibration and direct sunlight.
4. Properly use the TEC-specified label, tag, and ribbon.
5. DO NOT STORE the labels, tags, and ribbons in locations exposed to direct sunlight, high temperature, high humidity, dust, or gas.
6. Place the printer on a level surface.

CONTENTS

| | |
|-----------|------------------------|
| CHAPTER 1 | SPECIFICATIONS |
| CHAPTER 2 | BEFORE STARTING UP |
| CHAPTER 3 | INSTALLING THE PRINTER |
| CHAPTER 4 | OPERATION |
| CHAPTER 5 | MAINTENANCE |

APPLICABLE MODEL

B-30-S1-EU, UK, US, EU P, UK P, US P
 B-30-H1-EU, UK, US, EU P, UK P, US P
 B-30-C1-EU, UK, US, EU P, UK P, US P
 B-30-S2-EU, UK, MA, EU P, UK P
 B-30-H2-EU, UK, MA, EU P, UK P
 B-30-C2-EU, UK, MA, EU P, UK P
 B-30-S3-US P, AU P, UK P
 B-30-H3-AU P
 B-30-C3-AU P
 B-30-AS2-US P
 B-30-AS3-EU, UK, MA, EU P, US P
 B-30-AH3-EU
 B-30-S5-US P
 B-30-AS5-US P
 B-30-DS2-UK P

CHAPTER 1

SPECIFICATIONS

| | |
|---------------------|------|
| 1. PRINTER..... | 1- 1 |
| 2. SUPPLIES..... | 1- 9 |
| 3. RIBBON..... | 1- 9 |
| 4. DIMENSIONS..... | 1-10 |
| 5. ACCESSORIES..... | 1-10 |

1. PRINTER

● B-30-S1/H1/C1

| Item | Type | B-30-S1 | B-30-S1 P | B-30-H1 | B-30-H1 P | B-30-C1 | B-30-C1 P |
|----------------------------|------|--|-----------|--------------------|-----------|------------------|-----------|
| Power Requirement | | AC 120V \pm 10%, 60Hz . . . for US version AC 220V \pm 10%, 50Hz . . . for EU version AC 240V \pm 10%, 50Hz . . . for UK version | | | | | |
| Current Consumption | | 220W Max. (Standby: 35W) | | | | | |
| Temperature Limits | | 5°C to 40°C (41°F to 104°F) | | | | | |
| Relative Humidity | | 25% to 85% RH (no condensation) | | | | | |
| Print Head | | Thermal Print Head at 76.2 mm (3 inches) wide, 7.6 dots per mm (193 dots per inch) | | | | | |
| Printing Method | | Thermal Transfer or Thermal Direct | | | | | |
| Print Speed | | 50 mm (2 inches) per sec., 75 mm (3 inches) per sec., 100 mm (4 inches) per sec. | | | | | |
| Available Printing Width | | 75.8 mm (2.98 inches) Max. | | | | | |
| Bar Code Format | | EAN, UPC, ITF, Code 39, Code 93, Code 128, NW-7 | | | | | |
| Type Fonts | | Standard font, Bold Face font, Reduced font, OCR-MA, OCR-B | | | | | |
| Rotation | | 0°, 90°, 180°, 270° | | | | | |
| Issue Method | | Batch | | Batch or On-demand | | Auto cut | |
| Weight | | 17 kg (37.5 lbs) | | | | 19 kg (41.9 lbs) | |
| Memory Card Interface | | 1 slot (for 32 KB SRAM card) | | | | | |
| Serial Interface (RS-232C) | | ○ | ○ | ○ | ○ | ○ | ○ |
| Centronics Interface | | △ | ○ | △ | ○ | △ | ○ |
| Rewinder B-1103 | | △ | △ | △ | △ | — | — |
| Rewinder B-1103R | | △ | △ | △ | △ | — | — |
| Stacker B-1403 | | — | — | — | — | △ | △ |

○: Standard △: Option

● B-30-S2/H2/C2 (EU, UK version only)

| Item | Type | B-30-S2 | B-30-S2 P | B-30-H2 | B-30-H2 P | B-30-C2 | B-30-C2 P |
|----------------------------|------|--|-----------|--------------------|-----------|------------------|-----------|
| Power Requirement | | AC 220V \pm 10%, 50Hz . . . for EU version AC 240V \pm 10%, 50Hz . . . for UK version | | | | | |
| Current Consumption | | 220W Max. (Standby: 35W) | | | | | |
| Temperature Limits | | 5°C to 40°C (41°F to 104°F) | | | | | |
| Relative Humidity | | 25% to 85% RH (no condensation) | | | | | |
| Print Head | | Thermal Print Head at 76.2 mm (3 inches) wide, 7.6 dots per mm (193 dots per inch) | | | | | |
| Printing Method | | Thermal Transfer or Thermal Direct | | | | | |
| Print Speed | | 50 mm (2 inches) per sec., 75 mm (3 inches) per sec., 100 mm (4 inches) per sec. | | | | | |
| Available Printing Width | | 75.8 mm (2.98 inches) Max. | | | | | |
| Bar Code Format | | EAN, UPC, ITF, Code 39, Code 93, Code 128, NW-7 | | | | | |
| Type Fonts | | Standard font, Bold Face font, Reduced font, Outline font, OCR-MA, OCR-B | | | | | |
| Rotation | | 0°, 90°, 180°, 270° | | | | | |
| Issue Method | | Batch | | Batch or On-demand | | Auto cut | |
| Weight | | 17 kg (37.5 lbs) | | | | 19 kg (41.9 lbs) | |
| Memory Card Interface | | 1 slot (for 32 KB or 64 KB SRAM card) | | | | | |
| Serial Interface (RS-232C) | | ○ | ○ | ○ | ○ | ○ | ○ |
| Centronics Interface | | △ | ○ | △ | ○ | △ | ○ |
| Memory Card MC32-EX | | △ | △ | △ | △ | △ | △ |
| Memory Card MC64-EX | | △ | △ | △ | △ | △ | △ |
| Rewinder B-1103 | | △ | △ | △ | △ | — | — |
| Rewinder B-1103R | | △ | △ | △ | △ | — | — |
| Stacker B-1403 | | — | — | — | — | △ | △ |

○: Standard △: Option

● B-30-S3/H3/C3 (US, AU version only)

| Item | Version | S3-US P | S3-AU P | H3-AU P | C3-AU P |
|----------------------------|---------|--|--------------------|--------------------|-----------------|
| Power Requirement | | AC 120V ± 10%, 60Hz | AC240V ± 10%, 50Hz | | |
| Current Consumption | | 220W Max. (Standby: 35W) | | | |
| Temperature Limits | | 5°C to 40°C (41°F to 104°F) | | | |
| Relative Humidity | | 25% to 85% RH (no condensation) | | | |
| Print Head | | Thermal Print Head at 76.2 mm (3 inches) wide, 7.6 dots per mm (193 dots per inch) | | | |
| Printing Method | | Thermal Transfer or Thermal Direct | | | |
| Print Speed | | 50 mm (2 inches) per sec., 75 mm (3 inches) per sec., 100 mm (4 inches) per sec. | | | |
| Available Printing Width | | 75.8 mm (2.98 inches) Max. | | | |
| Bar Code Format | | EAN, UPC, ITF, Code 39, Code 93, Code 128, NW-7 | | | |
| Type Fonts | | Standard font, Bold Face font, Reduced font, Outline font, OCR-MA, OCR-B | | | |
| Rotation | | 0°, 90°, 180°, 270° | | | |
| Issue Method | | Batch | | Batch or on-demand | Auto cut |
| Weight | | 17 kg (37.5 lbs.) | | | 19kg (41.9lbs.) |
| Memory Card Interface | | 1 slot (for 32 KB or 64 KB SRAM card) | | | |
| Serial Interface (RS-232C) | | ○ | ○ | ○ | ○ |
| Centronics Interface | | ○ | ○ | ○ | ○ |
| Memory Card: MC32-EX | | △ | ○ | ○ | ○ |
| Memory Card: MC64-EX | | △ | △ | △ | △ |
| Keyboard KB-30-NP | | △ | ○ | ○ | ○ |
| Rewinder B-1103 | | △ | △ | △ | - |
| Rewinder B-1103R | | △ | △ | △ | - |
| Rewinder unit B-1103M | | △ | △ | △ | - |
| Cutter unit B-1203M | | △ | △ | - | ○ |
| Stacker B-1403 | | △ | △ | - | △ |

○: Standard △: Option

● B-30-AS2 (US version only)

| Item | Model | B-30-AS2-US P |
|--------------------------|-------|---|
| Power Requirement | | AC 120V \pm 10%, 60Hz |
| Current Consumption | | 220W Max. (Standby: 35W) |
| Temperature Limits | | 5°C to 40°C (41°F to 104°F) |
| Relative Humidity | | 25% to 85% RH (no condensation) |
| Print Head | | Thermal Print Head at 76.2 mm (3 inches) wide, 10.5 dots per mm (266 dots per inch) |
| Printing Method | | Thermal Transfer or Thermal Direct |
| Print Speed | | 50 mm (2 inches) per sec., 75 mm (3 inches) per sec., 100 mm (4 inches) per sec. |
| Available Printing Width | | 72.9 mm (2.87 inches) Max. |
| Bar Code Format | | EAN, UPC, ITF, Code 39, Code 93, Code 128, NW-7 |
| Type Fonts | | Standard font, Bold Face font, Reduced font, Outline font, OCR-MA, OCR-B |
| Rotation | | 0°, 90°, 180°, 270° |
| Issue Method | | Batch |
| Weight | | 17 kg (37.5 lbs.) |
| Interface | | Memory Card Interface 1 slot (for 32 KB or 64 KB SRAM card) Serial Interface (RS-232C) Centronics Interface |
| Option | | Memory Card: MC32-EX, MC64-EX Keyboard: KB-30-EX Rewinder: B-1103, B-1103R |

● B-30-DS2 (UK version only)

| Item | Model | B-30-DS2-UK P |
|--------------------------|-------|--|
| Power Requirement | | AC 240V \pm 10%, 50Hz |
| Current Consumption | | 220W Max. (Standby: 35W) |
| Temperature Limits | | 5°C to 40°C (41°F to 104°F) |
| Relative Humidity | | 25% to 85% RH (no condensation) |
| Print Head | | Thermal Print Head at 76.2 mm (3 inches) wide, 6 dots per mm (152 dots per inch) |
| Printing Method | | Thermal Transfer or Thermal Direct |
| Print Speed | | 50 mm (2 inches) per sec., 75 mm (3 inches) per sec., 100 mm (4 inches) per sec. |
| Available Printing Width | | 74.8 mm (2.94 inches) Max. |
| Bar Code Format | | EAN, UPC, ITF, Code 39, Code 93, Code 128, NW-7 |
| Type Fonts | | Standard font, Bold Face font, Reduced font, Outline font, OCR-MA, OCR-B |
| Rotation | | 0°, 90°, 180°, 270° |
| Issue Method | | Batch |
| Weight | | 17 kg (37.5 lbs.) |
| Interface | | Memory Card Interface 1 slot (for 32 KB SRAM card) Serial Interface (RS-232C) Centronics Interface |
| Memory Card | | MC32-EX |
| Keyboard | | KB-30-EX |
| Option | | Rewinder: B-1103, B-1103R |

● B-30-AS3

| Item \ Version | US P | EU | EU P | UK | UK P |
|----------------------------|---|---------------------|------|---------------------|------|
| Power Requirement | AC 120V ± 10%, 60Hz | AC 220V ± 10%, 50Hz | | AC 240V ± 10%, 50Hz | |
| Current Consumption | 220W Max. (Standby: 35W) | | | | |
| Temperature Limits | 5°C to 40°C (41°F to 104°F) | | | | |
| Relative Humidity | 25% to 85% RH (no condensation) | | | | |
| Print Head | Thermal Print Head at 76.2 mm (3 inches) wide, 10.5 dots per mm (266 dots per inch) | | | | |
| Printing Method | Thermal Transfer or Thermal Direct | | | | |
| Print Speed | 50 mm (2 inches) per sec., 75 mm (3 inches) per sec., 100 mm (4 inches) per sec. | | | | |
| Available Printing Width | 72.9 mm (2.87 inches) Max. | | | | |
| Bar Code Format | EAN, UPC, ITF, Code 39, Code 93, Code 128, NW-7 | | | | |
| Type Fonts | Standard font, Bold Face font, Reduced font, Outline font, OCR-MA, OCR-B | | | | |
| Rotation | 0°, 90°, 180°, 270° | | | | |
| Issue Method | Batch, On-demand (option), or Auto cut (option) | | | | |
| Weight (approx.) | 17 kg (37.5 lbs.) | | | | |
| Memory Card Interface | 1 slot (for 32 KB or 64 KB SRAM card) | | | | |
| Serial Interface (RS-232C) | ○ | ○ | ○ | ○ | ○ |
| Centronics Interface | ○ | △ | ○ | △ | ○ |
| Keyboard KB-30-EX | △ | ○ | ○ | ○ | ○ |
| Memory Card MC32-EX | △ | △ | △ | △ | △ |
| Memory Card MC64-EX | △ | △ | △ | △ | △ |
| Rewinder B-1103 | △ | △ | △ | △ | △ |
| Rewinder B-1103R | △ | △ | △ | △ | △ |
| Rewinder unit B-1103M | △ | △ | △ | △ | △ |
| Cutter unit B-1203M | △ | △ | △ | △ | △ |
| Stacker B-1403 | △ | △ | △ | △ | △ |

○: Standard △: Option

● B-30-AH3

| Item | Model B-30-AH3-EU |
|--------------------------|---|
| Power Requirement | AC 220V \pm 10%, 50Hz |
| Current Consumption | 220W Max. (Standby: 35W) |
| Temperature Limits | 5°C to 40°C (41°F to 104°F) |
| Relative Humidity | 25% to 85% RH (no condensation) |
| Print Head | Thermal Print Head at 76.2 mm (3 inches) wide, 10.5 dots per mm (266 dots per inch) |
| Printing Method | Thermal Transfer or Thermal Direct |
| Print Speed | 50 mm (2 inches) per sec., 75 mm (3 inches) per sec., 100 mm (4 inches) per sec. |
| Available Printing Width | 72.9 mm (2.87 inches) Max. |
| Bar Code Format | EAN, UPC, ITF, Code 39, Code 93, Code 128, NW-7 |
| Type Fonts | Standard font, Bold Face font, Reduced font, Outline font, OCR-MA, OCR-B |
| Rotation | 0°, 90°, 180°, 270° |
| Issue Method | On-demand or Batch |
| Weight | 17 kg (37.5 lbs.) |
| Interface | Memory Card Interface 1 slot (for 32 KB or 64 KB SRAM card) |
| Option | Serial Interface (RS-232C) |
| | Centronics Interface |
| | Memory Card: MC32-EX, MC64-EX |
| | Keyboard: KB-30-EX |
| | Rewinder: B-1103, B-1103R |

● B-30-S5 (US version only)

| Item | Model B-30-S5-US P |
|--------------------------|---|
| Power Requirement | AC 120V ± 10%, 60Hz |
| Current Consumption | 220W Max. (Standby: 35W) |
| Temperature Limits | 5°C to 40°C (41°F to 104°F) |
| Relative Humidity | 25% to 85% RH (no condensation) |
| Print Head | Thermal Print Head at 76.2 mm (3 inches) wide, 7.6 dots per mm (193 dots per inch) |
| Printing Method | Thermal Transfer or Thermal Direct |
| Print Speed | 50 mm (2 inches) per sec., 75 mm (3 inches) per sec., 100 mm (4 inches) per sec. |
| Available Printing Width | 75.8 mm (2.98 inches) Max. |
| Bar Code Format | EAN, UPC, ITF, Code 39, Code 93, Code 128, NW-7, MSI |
| Type Fonts | Standard font, Bold Face font, Reduced font, Outline font, OCR-MA, OCR-B |
| Rotation | 0°, 90°, 180°, 270° |
| Issue Method | Batch, On-demand (option), or Auto cut (option) |
| Weight | 17 kg (37.5 lbs.) |
| Interface | Memory Card Interface 1 slot (for 32 KB or 64 KB SRAM card) Serial Interface (RS-232C) Centronics Interface |
| Option | Memory Card: MC32-EX, MC64-EX Keyboard: KB-30-EX Rewinder: B-1103, B-1103R Rewinder unit: B-1103M Cutter unit: B-1203M Stacker: B-1403 |

● B-30-AS5 (US version only)

| Item | Model B-30-AS5-US P |
|--------------------------|---|
| Power Requirement | AC 120V ± 10%, 60Hz |
| Current Consumption | 220W Max. (Standby: 35W) |
| Temperature Limits | 5°C to 40°C (41°F to 104°F) |
| Relative Humidity | 25% to 85% RH (no condensation) |
| Print Head | Thermal Print Head at 76.2 mm (3 inches) wide, 10.5 dots per mm (266 dots per inch) |
| Printing Method | Thermal Transfer or Thermal Direct |
| Print Speed | 50 mm (2 inches) per sec., 75 mm (3 inches) per sec., 100 mm (4 inches) per sec. |
| Available Printing Width | 72.9 mm (2.87 inches) Max. |
| Bar Code Format | EAN, UPC, ITF, Code 39, Code 93, Code 128, NW-7, MSI |
| Type Fonts | Standard font, Bold Face font, Reduced font, Outline font, OCR-MA, OCR-B |
| Rotation | 0°, 90°, 180°, 270° |
| Issue Method | Batch, On-demand (option), or Auto cut (option) |
| Weight | 17 kg (37.5 lbs.) |
| Interface | Memory Card Interface 1 slot (for 32 KB or 64 KB SRAM card) |
| | Serial Interface (RS-232C) |
| | Centronics Interface |
| Option | Memory Card: MC32-EX, MC64-EX |
| | Keyboard: KB-30-EX |
| | Rewinder: B-1103, B-1103R |
| | Rewinder unit: B-1103M |
| | Cutter unit: B-1203M |
| | Stacker: B-1403 |

2. SUPPLIES

● B-30-S1/H1/C1/S2/H2/C2/S3/H3/C3/S5

| Item | Supply Type | Label | Tag |
|---------------|-------------|--|--|
| Width | | 30 to 81 mm (1.18 to 3.18 inches) | |
| Length | | 15 to 152.4 mm (.59 to 6 inches) | |
| Thickness | | .13 to .17 mm (.005 to .006 inches) | .15 to .26 mm (.006 to .010 inches) |
| Roll Diameter | | 230 mm (9 inches) Max. | |

● B-30-AS2/AS3/AH3/AS5

| Item | Supply Type | Label | Tag |
|---------------|-------------|--|--|
| Width | | 30 to 81 mm (1.18 to 3.18 inches) | |
| Length | | 15 to 160 mm (.59 to 6.29 inches) | |
| Thickness | | .13 to .17 mm (.005 to .006 inches) | .15 to .26 mm (.006 to .010 inches) |
| Roll Diameter | | 230 mm (9 inches) Max. | |

3. RIBBON

| | |
|---------------|---|
| Ribbon Type | One-time carbon: Black |
| Width | 48 mm (1.89 inches), 58 mm (2.28 inches), 83 mm (3.26 inches) |
| Length | 400 m (1312 feet) |
| Roll Diameter | Max. 71 mm (2.79 inches) |

4. USING B-1403

| Item | Supply Type | Label | Tag |
|--------|-------------|--|----------------------------------|
| Paper | | Paper with a minimum label-to-label gap of 4 mm. | Perforated paper cannot be used. |
| Width | | 30 ~ 81 mm (1.18 to 3.19 inches) | 30 ~ 81 mm (1.18 to 3.19 inches) |
| Length | | 30 ~ 80 mm (1.18 to 3.15 inches) | 30 ~ 105 mm (1.18 to 4.1 inches) |

4. DIMENSIONS (approximate)

■ Printer

mm (inches)

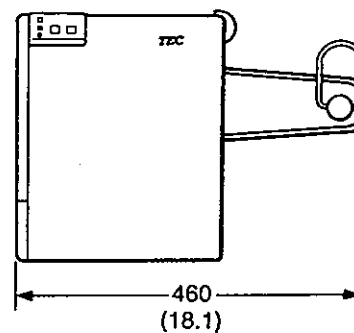
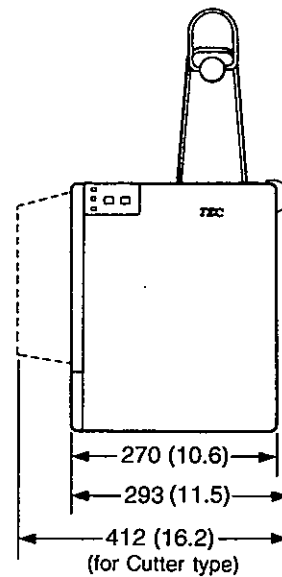
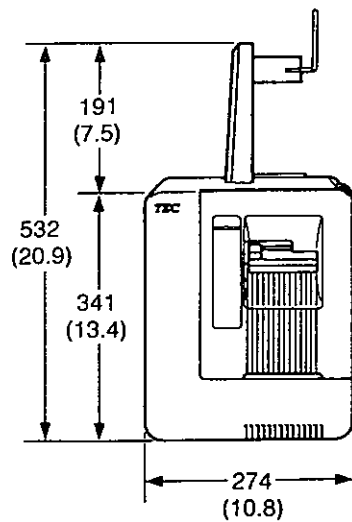

■ Keyboard

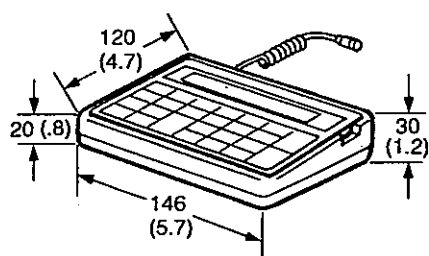

Cable length: 1.5 m (4.92 feet)

Weight: 430g (.95 lbs.)

5. ACCESSORIES

Make sure you have all the items shown the accessory list on the carton.

NOTE : The specifications are subject to change without notice.

CHAPTER 2

BEFORE STARTING UP

| | |
|--------------------------|-----|
| 1. OVERVIEW | 2-1 |
| 1.1. Front View | 2-1 |
| 1.2. Side View | 2-5 |
| 1.3. Keyboard Unit | 2-5 |
| 2. KEY FUNCTIONS | 2-6 |

1. OVERVIEW

1.1. Front View

● B-30-S1/DS2

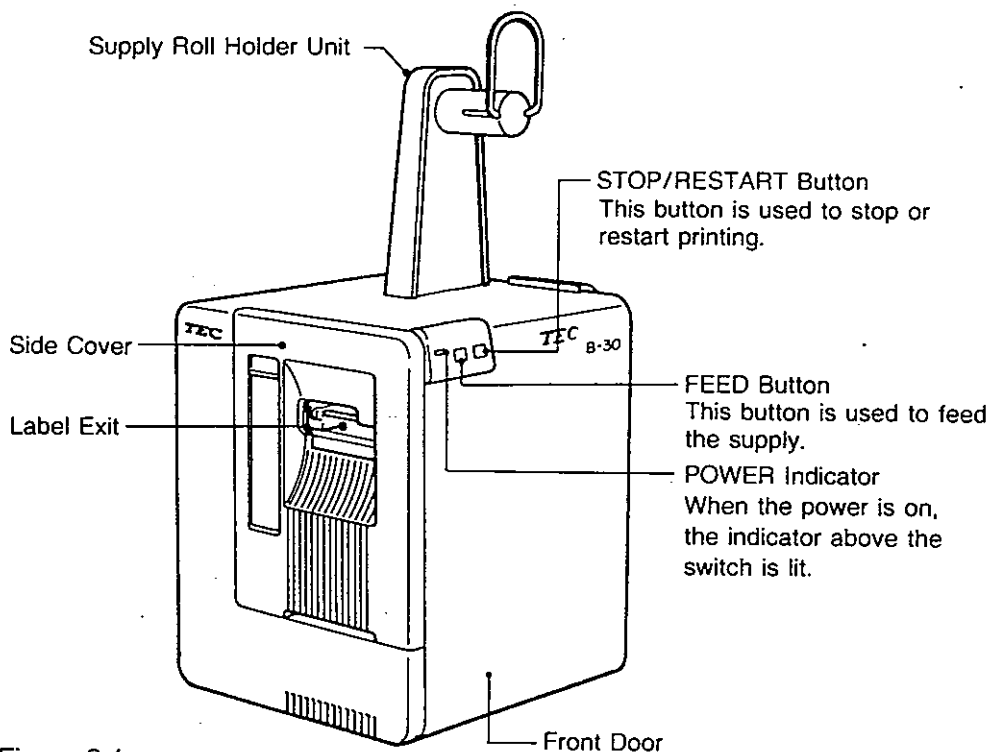

Figure 2-1.

● B-30-S2/S3/AS2/AS3/AS5

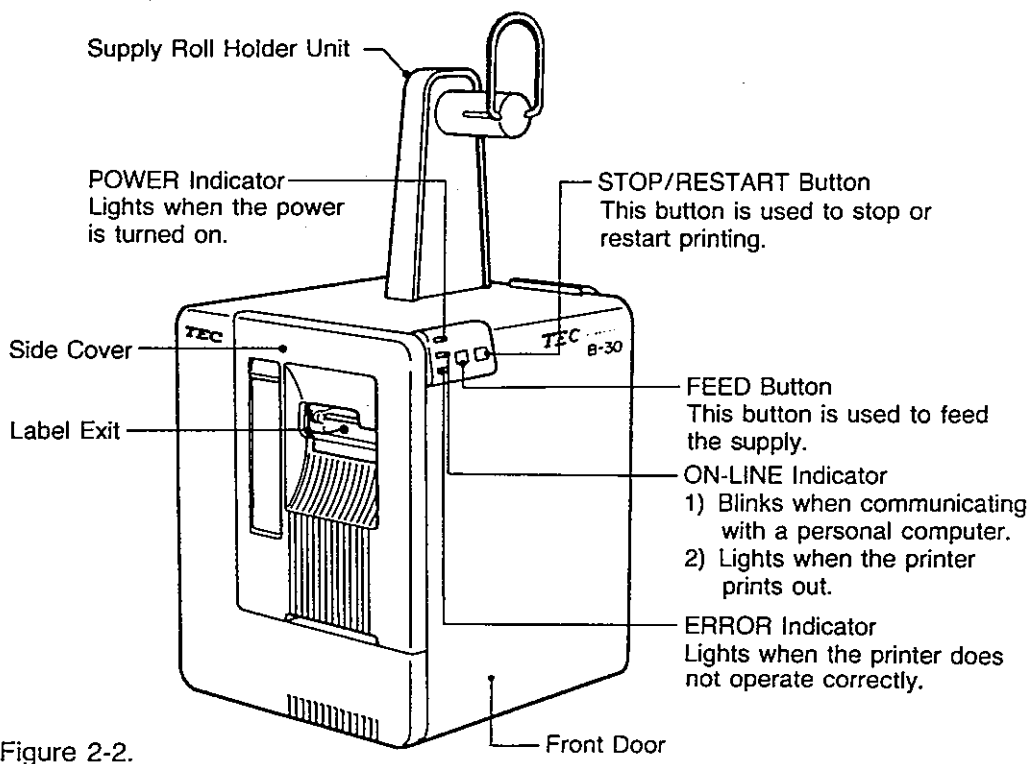

Figure 2-2.

● B-30-H1

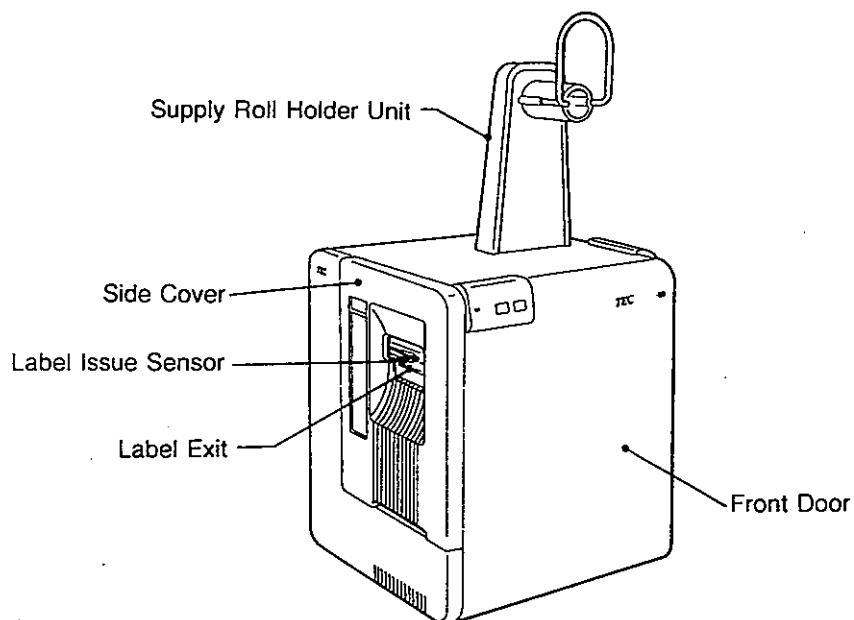

Figure 2-3.

● B-30-H2/H3/AH3

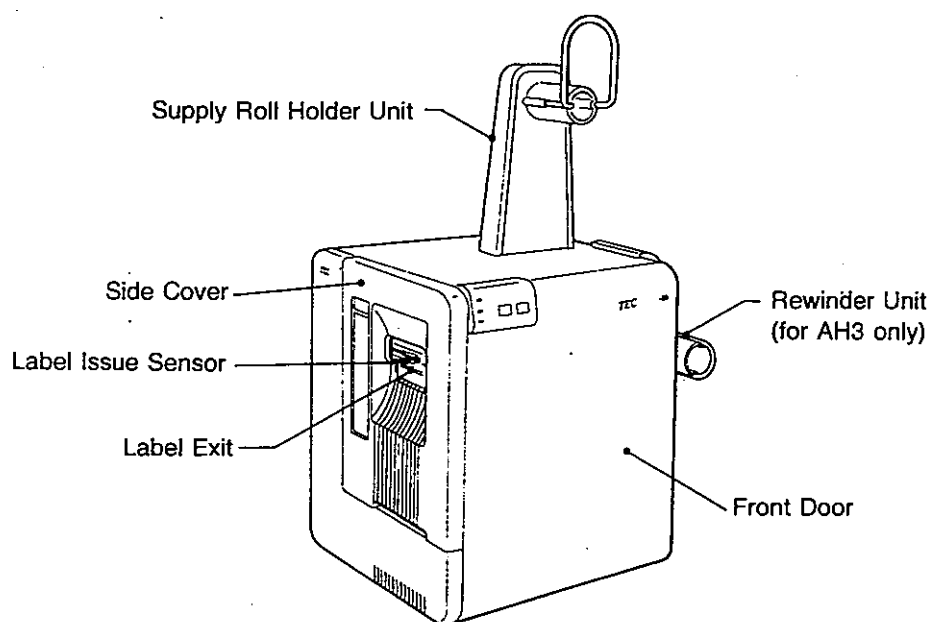

Figure 2-4.

● B-30-S3/AS3/S5/AS5 (with Rewinder unit B-1103M...option)

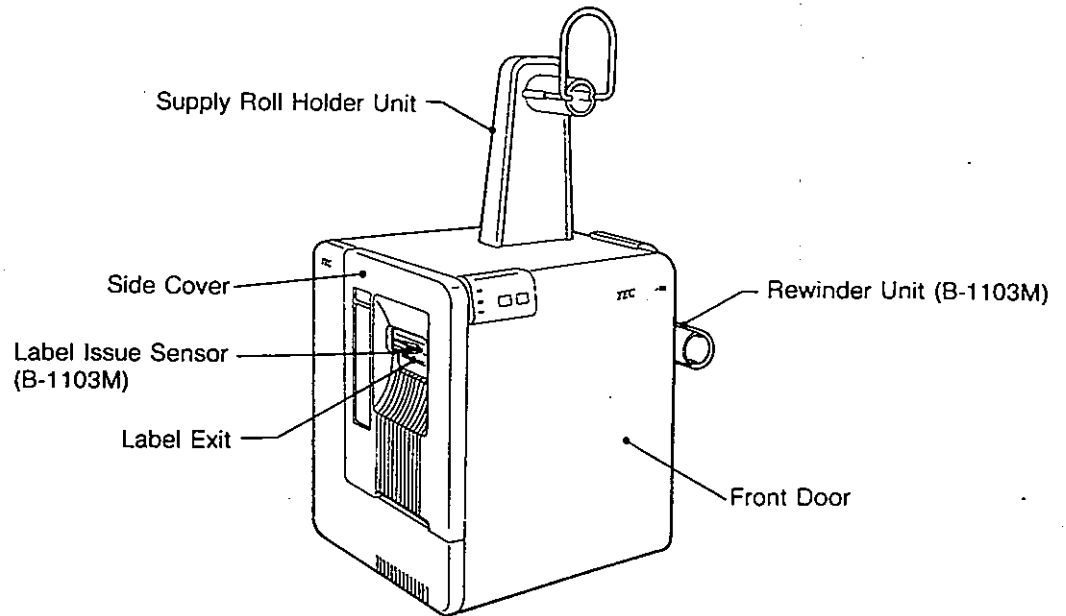

Figure 2-5.

● B-30-C1

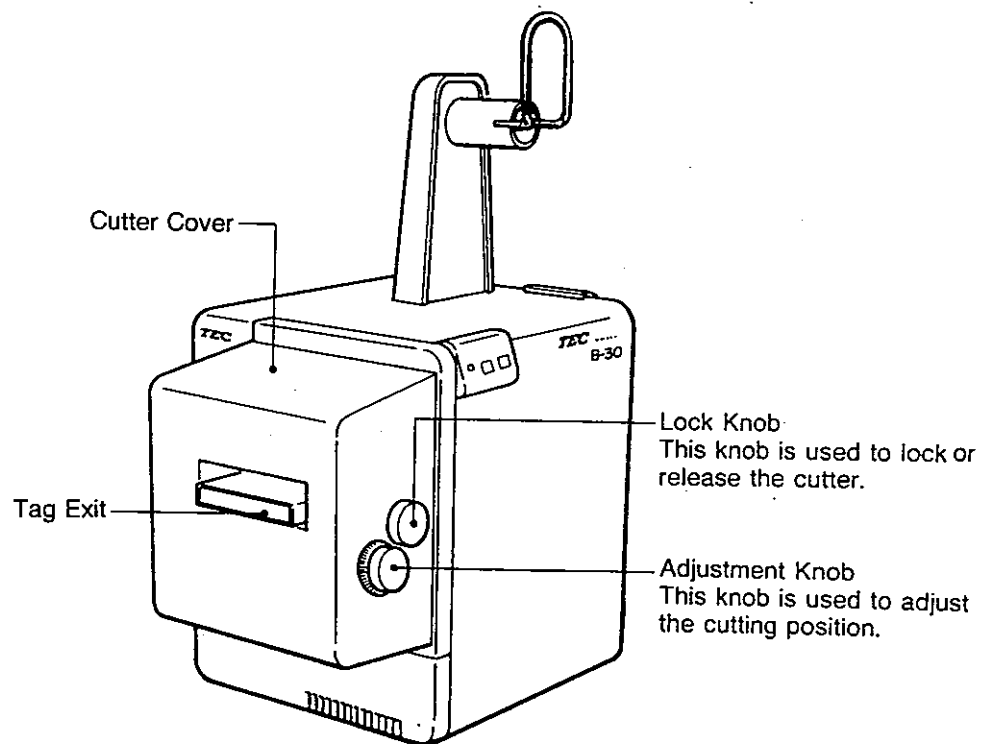

Figure 2-6.

● B-30-C2/C3

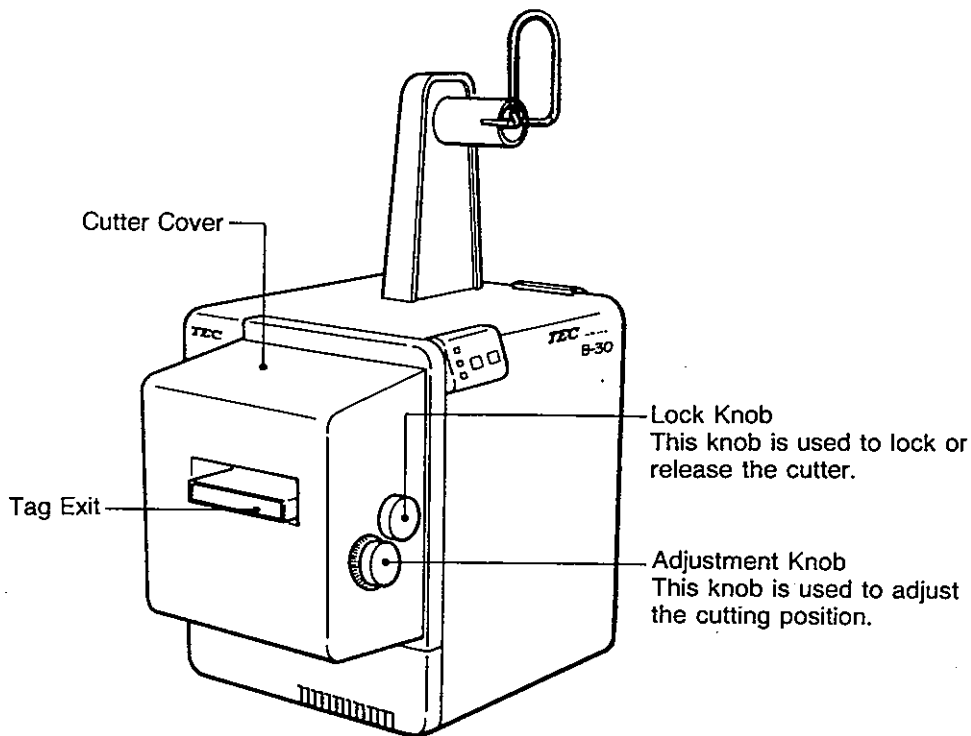

Figure 2-7.

● B-30-S3/AS3/S5/AS5 (with Cutter unit B-1203M....Option)

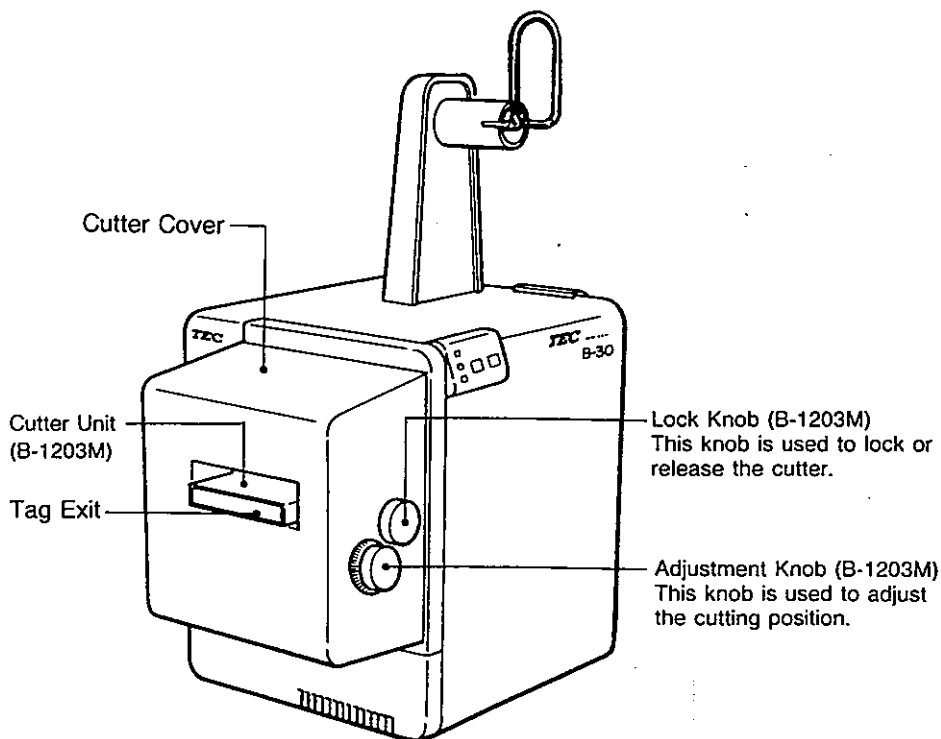

Figure 2-8.

1.2. Side View

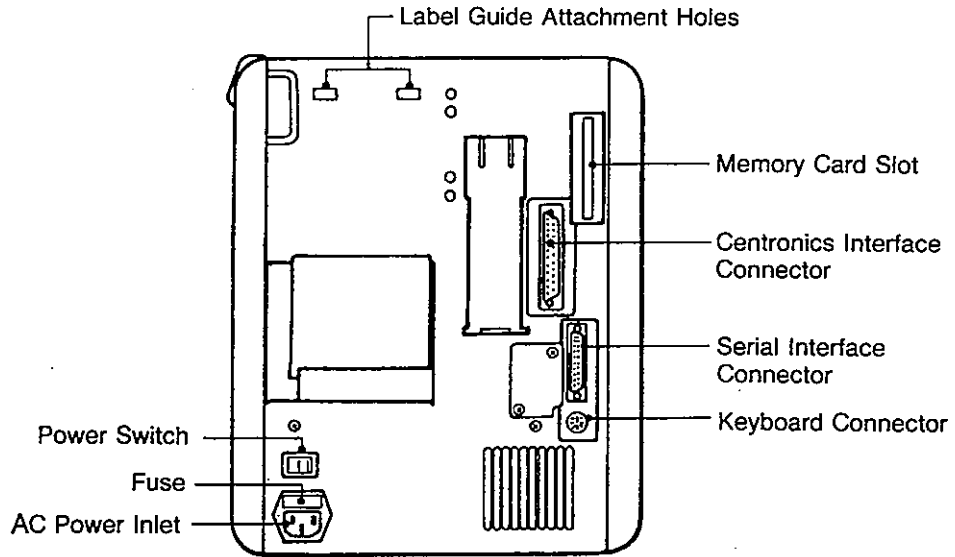

Figure 2-9.

1.3. Keyboard Unit

● KB-30-EX

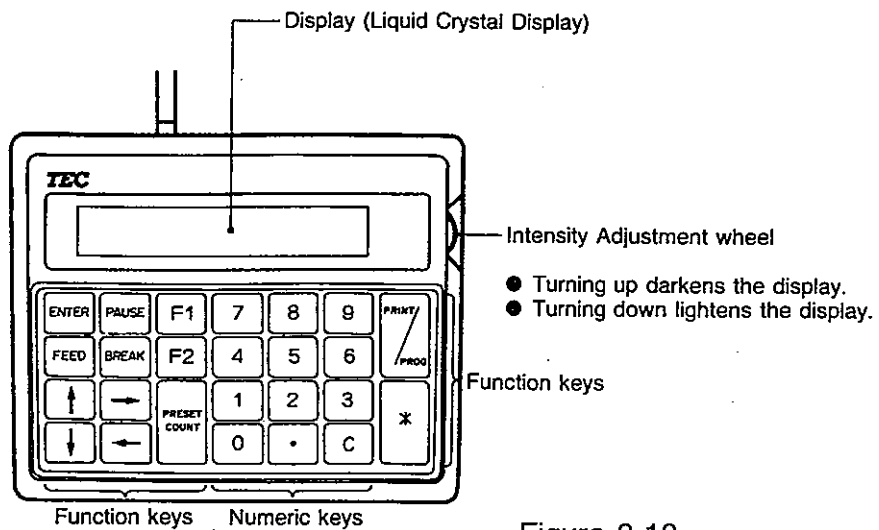

Figure 2-10.

● KB-30-NP

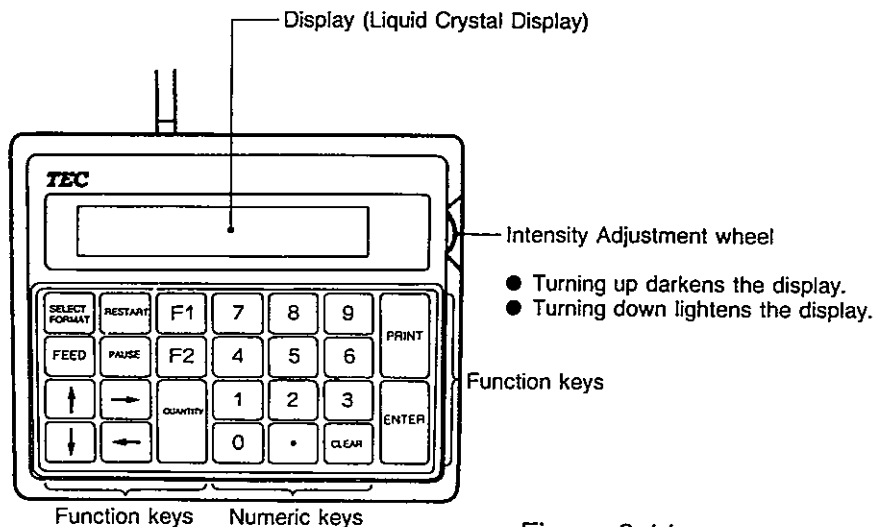



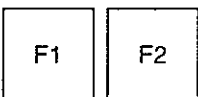

























Figure 2-11.

2. KEY FUNCTIONS

● KB-30-EX

| Key | Function |
|---|---|
|  | This key is used for enter-clear of a numeric key. It is also used to release the printer from an error mode. |
|  | This key is used to enter the data recall mode. |
|  | This key is used to feed and cut supplies. NOTICE: The available functions are different depending on the program used. |
|  | Special assigned function. (These keys are used by service personnel.) |
|  | This key is used to temporarily stop printing. It is also used to restart printing supplies after pausing. |
|  | This key is used to preset the number of tags/labels you want to print. |
|  | This key is used to start printing. It is also used to register the next data while the supplies are being printed. |
|  | This key is used to input the data to the printer. |
|  | This key is used to separate plural input data. |
|  | These keys are used to enter numeric data. |
| Other keys | These keys are not used during normal operations. (These keys are also used by service personnel.) |

● KB-30-NP

| Key | Function |
|--|---|
|  | This key is used for enter-clear of a numeric key. It is also used to release the printer from an error mode. |
|  | This key is used to enter the data to the printer. |
|  | This key is used to feed and cut supplies. NOTICE: The available functions are different depending on the program used. |
|  | This key is used to temporarily stop printing. |
|  | This key is used to start printing. |
|  | This key is used to preset the number of tags/labels you want to print. |
|  | This key is used to select a print format. |
|  | This key is used to select a print format. |
|  | This key is used to separate plural input data. |
|   | F2 is a purchase order separator. (These keys are also used by service personnel.) |
|  ~  | These keys are used to enter numeric data. |
|     | These keys are used to during normal operations to move the cursor within a data field and to display formats. |

CHAPTER 3

INSTALLING THE PRINTER

| | |
|---|-----|
| 1. CONNECTING THE POWER CORD AND CABLES..... | 3-1 |
| 2. INSTALLING THE SUPPLY ROLL HOLDER..... | 3-1 |
| 3. INSTALLING THE SUPPLY STOPPER B | 3-2 |
| 4. INSTALLING THE PAPER GUIDE | 3-3 |
| 5. INSTALLING THE BACKING PAPER GUIDE..... | 3-3 |
| 6. MOUNTING THE LOCK AND ADJUSTMENT KNOBS | 3-4 |
| ■ Adjusting the cutting position | 3-4 |
| 7. INSTALLING THE STACKER..... | 3-4 |
| 8. INSTALLING THE REWINDER B-1103..... | 3-5 |

1. CONNECTING THE POWER CORD AND CABLES

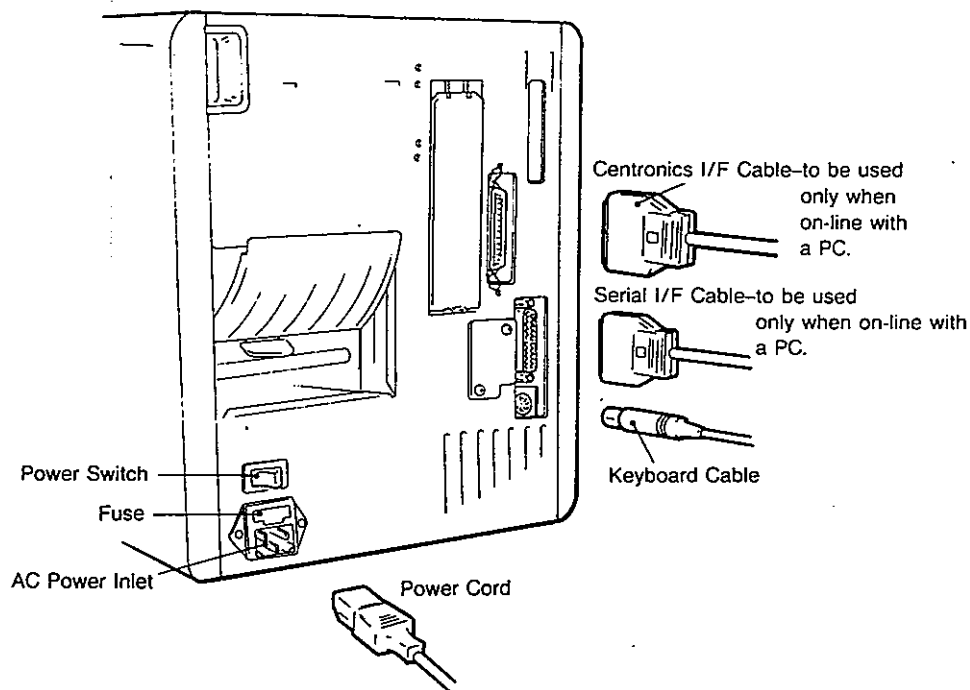

Figure 3-1.

WARNING: The power switch must be off before connecting the power cord.

2. INSTALLING THE SUPPLY ROLL HOLDER

- Installing the supply roll holder on the top of the printer.
 - a. Remove the cover of the supply roll holder unit, and attach the supply stand to the top of the printer using the two wing screws.
 - b. Insert the cover over the top of the supply stand.

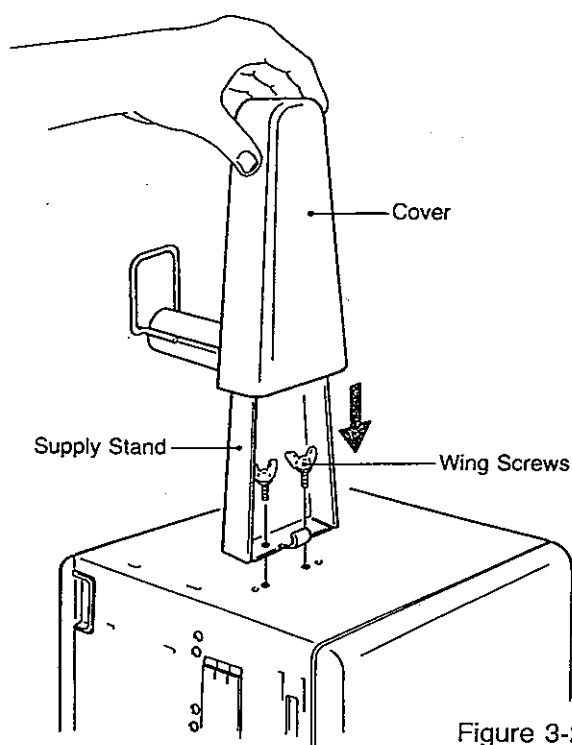

Figure 3-2.

- Installing the supply roll holder on the right side of the printer (except for B-30-S3/AS3 with Rewinder unit).
 - a. Remove the cover of the supply roll holder unit, then remove the supply spool from the supply stand.
 - b. Attach the supply stand to the right side of the printer using the two wing screws.
 - c. Mount the supply spool by inserting it into the horizontal mounting holes of the supply stand.
 - d. Attach the cover by inserting it horizontally from the side of the supply stand.

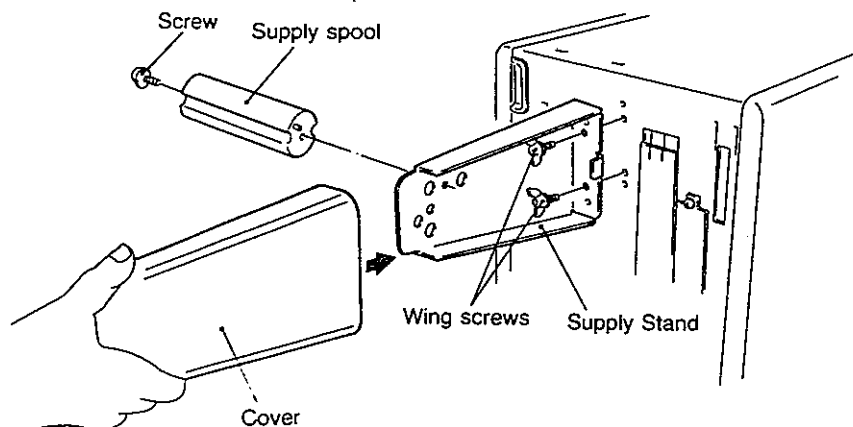

Figure 3-3.

3. INSTALLING THE SUPPLY STOPPER B

Install supply stopper B on the supply roll holder unit when using the narrow supply.

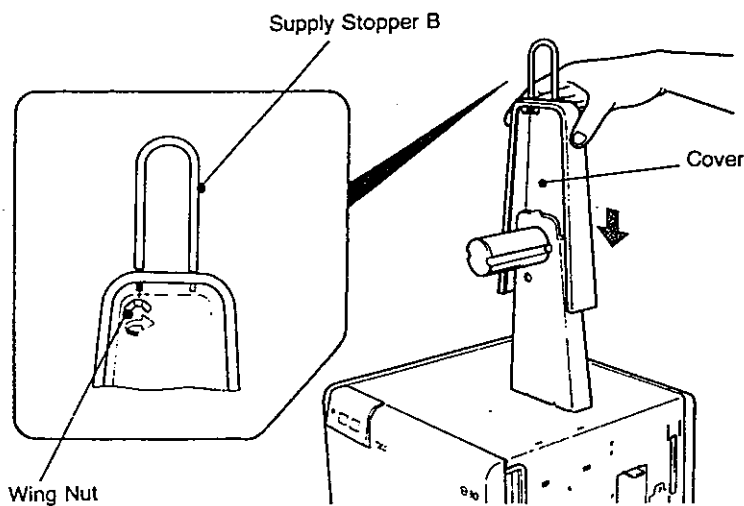

Figure 3-4.

4. INSTALLING THE PAPER GUIDE

Place the paper guide in the position shown below.

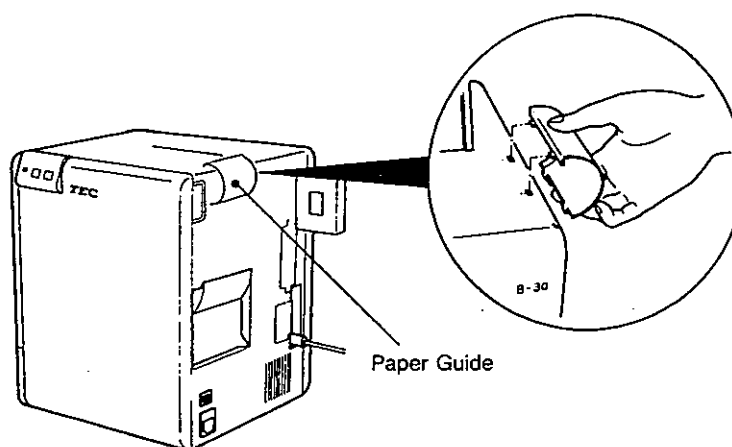

Figure 3-5.

5. INSTALLING THE BACKING PAPER GUIDE (for B-30-H1/H2/H3)

When issuing a label in the "On-demand" mode, mount the backing paper guide in the position shown below and eject the backing paper from the lower exit on the left side of the printer.

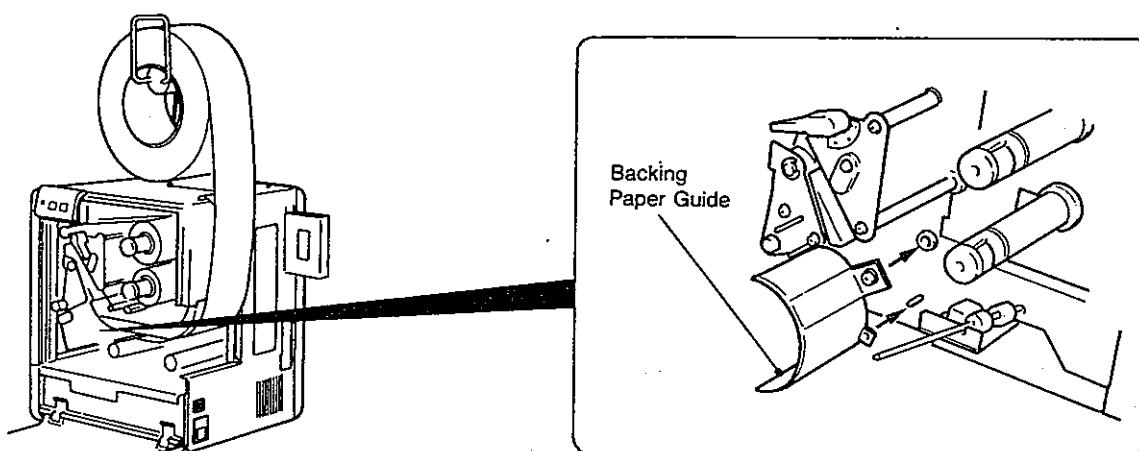

Figure 3-6.

6. MOUNTING THE LOCK AND ADJUSTMENT KNOBS (for Cutter type only)

Insert each knob. (Align the groove of the knob with the pin on the shaft.)

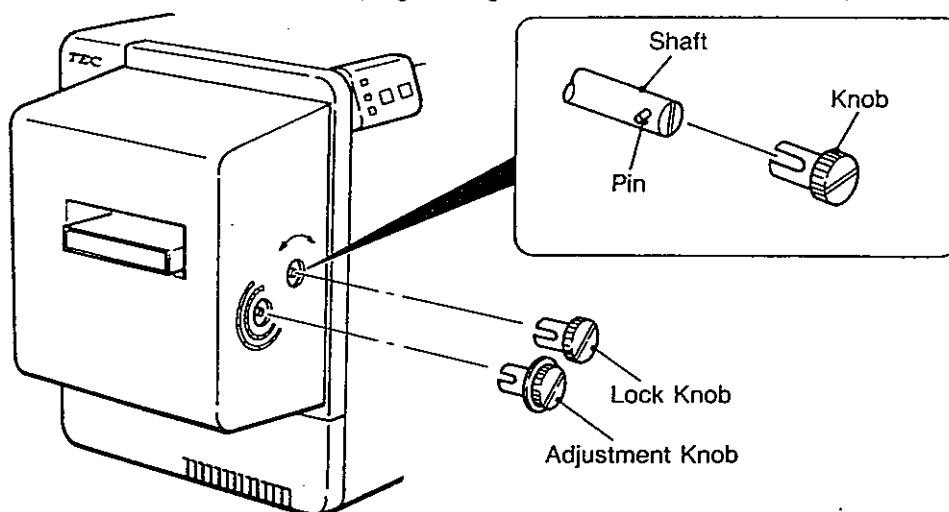

Figure 3-7.

NOTICE: When inserting the adjustment knob, make sure that the triangular indicator (▲) points to "55" on the scale.

■ Adjusting the cutting position

1. Turn the lock knob to the unlock position.
2. Set the adjustment knob to the designated position.
3. Turn the lock knob to the lock position.

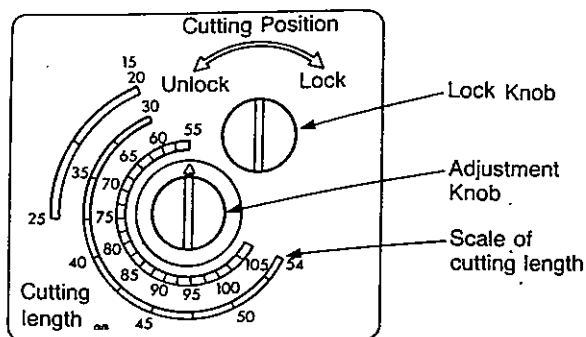

Figure 3-8.

1st scale: 55 mm ~ 108 mm Max.

2nd scale: 30 mm ~ 54 mm

3rd scale: 15 mm, 20 mm ~ 25 mm

7. INSTALLING THE STACKER (for Cutter type only)

Assemble the stacker and hang the tabs of the stacker on the tag exit.

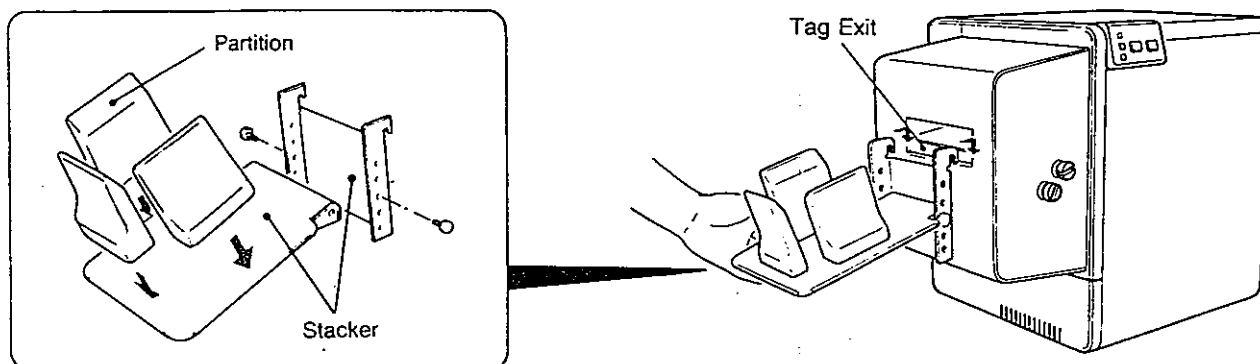

Figure 3-9.

8. INSTALLING THE REWINDER B-1103 (Option)

To rewind labels issued in batch printing mode, or backing paper in the on-demand printing mode, attach the Rewinder B-1103 (option) at the position shown below.

- Label (except for Cutter type)

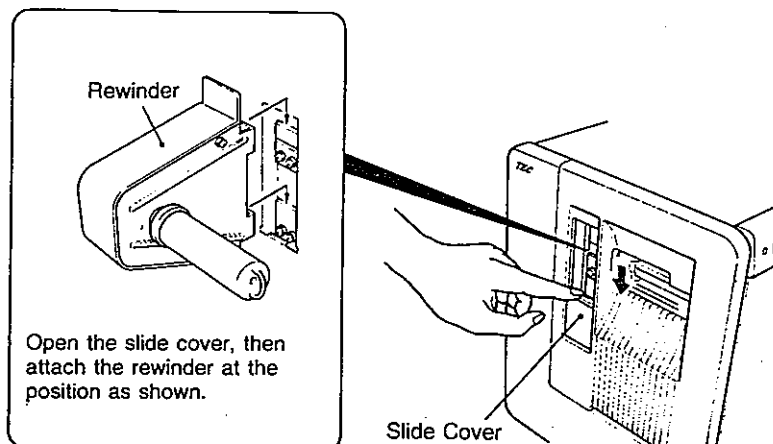

Figure 3-10.

- Backing Paper (for B-30-H1/H2/H3 only)

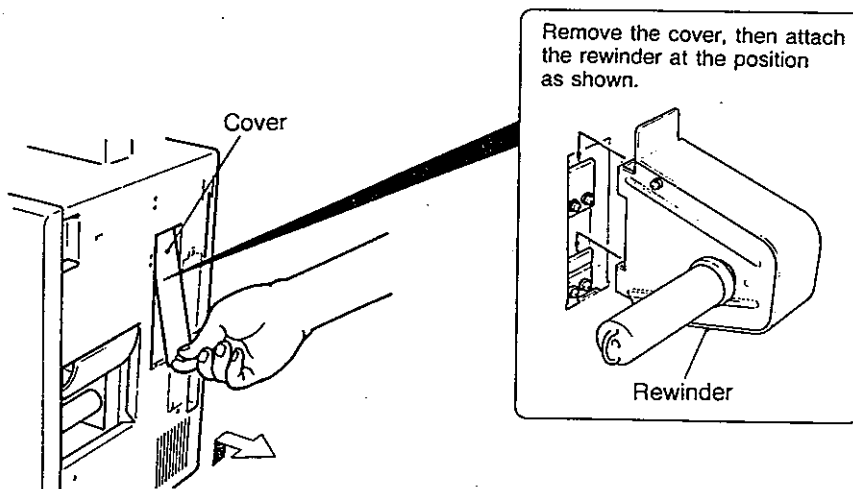

Figure 3-11.

- Backing Paper Threading

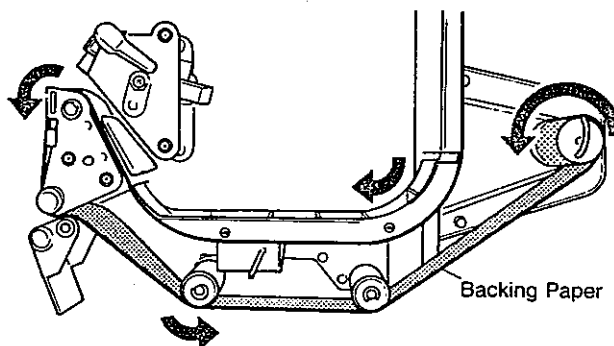

Figure 3-12.

NOTICE: When installing other optional equipments, refer to the owner's manual provided with those equipment.

CHAPTER 4

OPERATION

| | |
|---|------|
| 1. LOADING THE RIBBON..... | 4- 1 |
| 2. LOADING SUPPLIES | 4- 4 |
| 2.1. For B-30-S1/H1/C1/DS2..... | 4- 4 |
| 2.2. For B-30-S2/H2/C2/S3/H3/C3/AS2/AS3/AH3 | 4- 6 |
| 2.3. For B-30-S5/AS5..... | 4- 8 |
| ■ Threading the backing paper..... | 4-10 |
| 3. INSERTING THE MEMORY CARD..... | 4-11 |
| 4. ADJUSTING THE SENSORS..... | 4-12 |
| 4.1. Black Mark or Feed Gap Sensor | 4-12 |
| 4.2. Label Issue Sensor..... | 4-12 |

1. LOADING THE RIBBON

There are two types of supplies, standard paper and thermal paper.
DO NOT LOAD a ribbon when using thermal paper.

1. Turn the power off.
2. Open the front door.

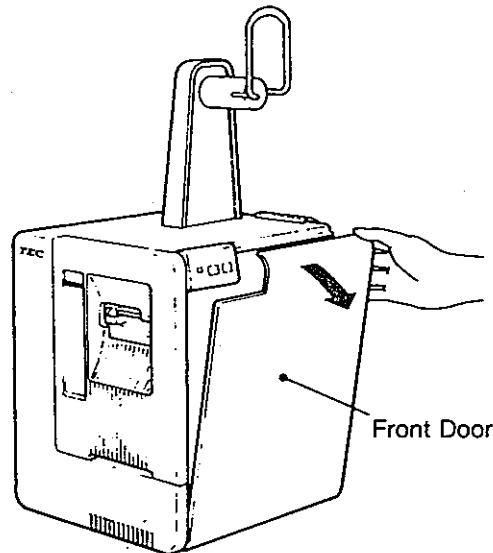

Figure 4-1.

3. Move the head lock lever to the right to release the print head.
4. Remove the supply if it has been loaded.

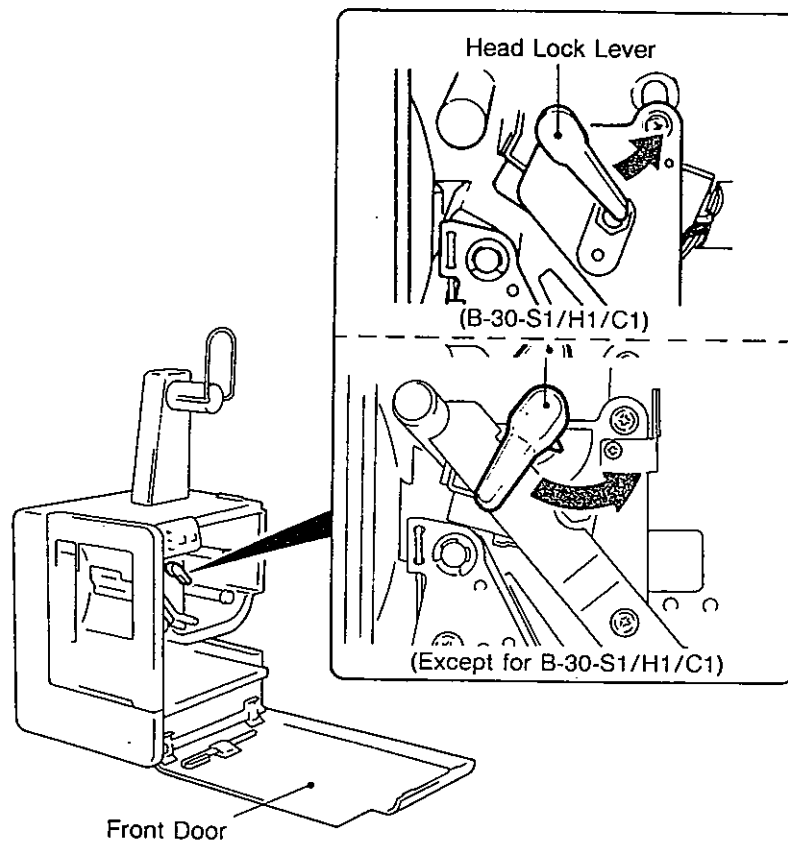

Figure 4-2.

5. Load the ribbon.
 - a. Guide the edge of the ribbon around the ribbon shaft.
 - b. Place the ribbon rolls onto the two shafts.
 - c. Insert the ribbon between the ribbon end sensor.

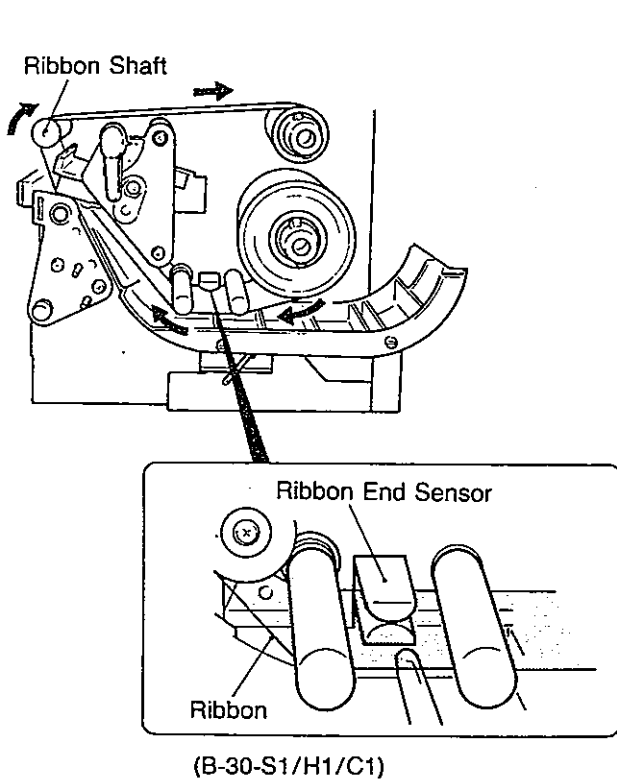

Figure 4-3.

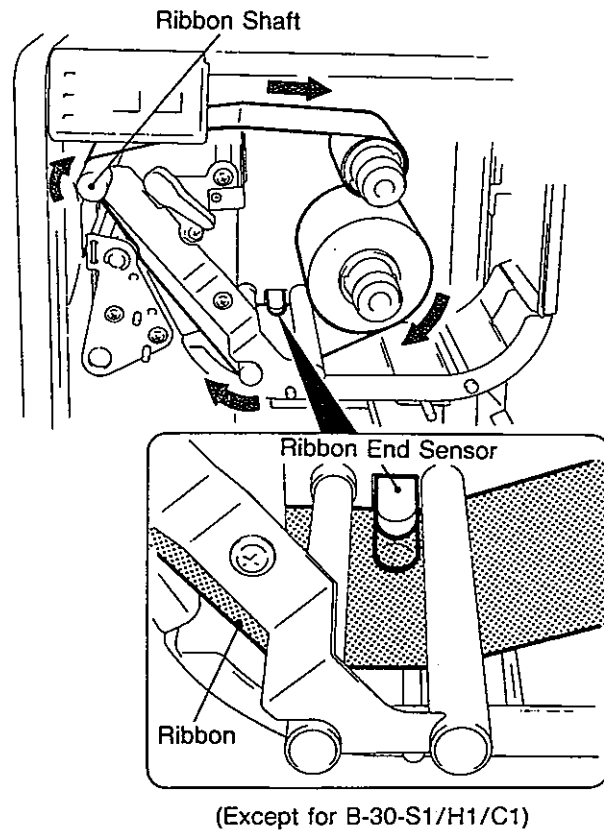

Figure 4-4.

6. Lock the ribbon rolls.
 - a. Match the notch on the supply and rewind reels with the protrusion on the shafts as shown.

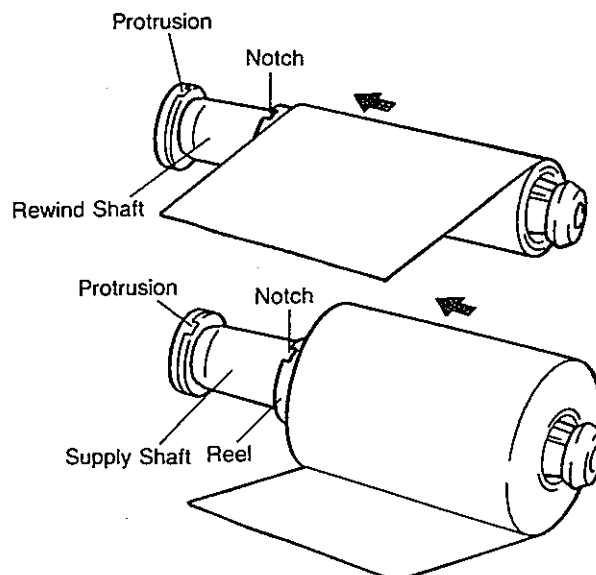

Figure 4-5.

- b. Pull the head of the shaft while holding the ribbon roll.

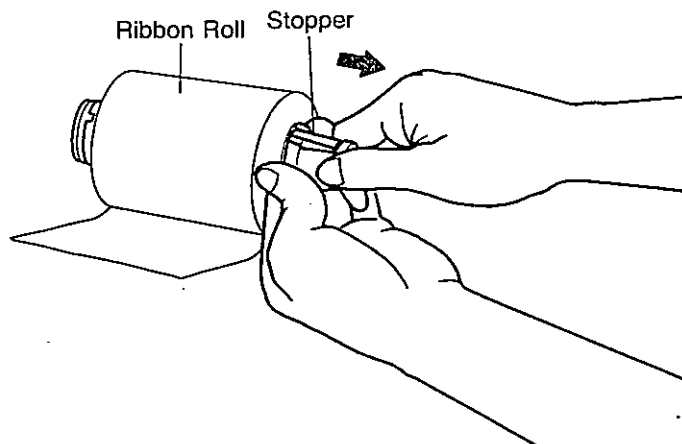

Figure 4-6.

NOTICE: Depress the stoppers when removing the ribbon roll.

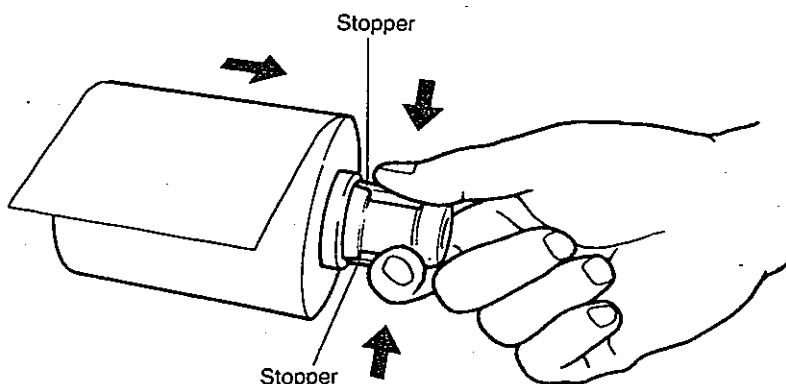

Figure 4-7.

7. Turn the rewind shaft as shown, to pull the ribbon tight.
8. Reload the supply (standard paper).
9. Move the head lock lever to the left to move the print head against the ribbon and platen.
10. Close the front door.

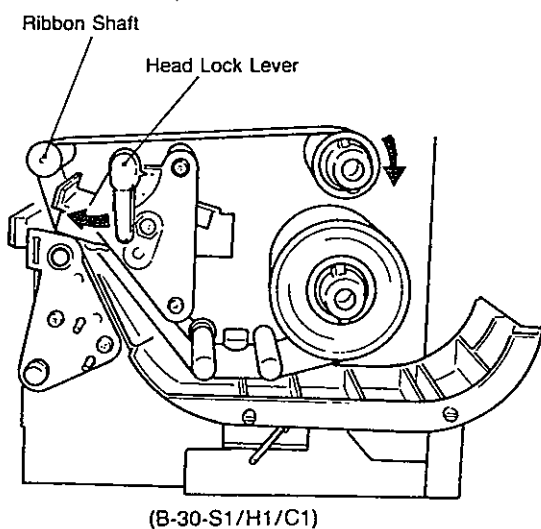

Figure 4-8.

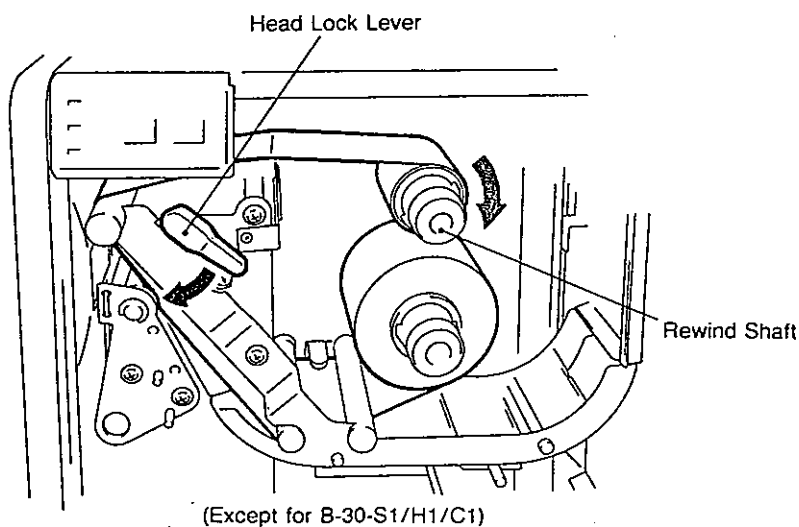

Figure 4-9.

2. LOADING SUPPLIES

2.1. For B-30-S1/H1/C1/DS2

The printer prints both tags and labels.

1. Turn the power off.
2. Place the supply roll onto the supply roll holder.
3. Open the front door.
4. Move the head lock lever to the right to release the print head.

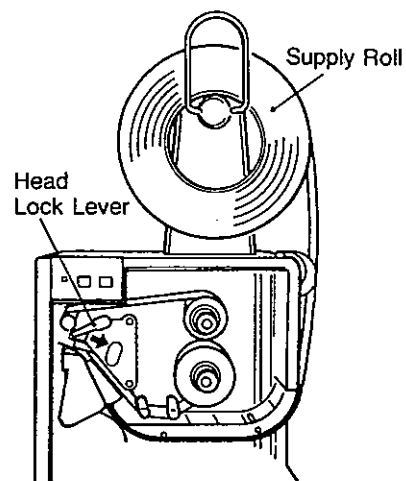

Figure 4-10.

5. Thread the supply as shown.
 - a. Pull enough supply out from the roll to reach the label exit (for H1 and S1 types) or platen (for C1 type).
 - b. Pull down and hold the guide roller lever, and slide the supply under the paper guide. Then release the lever.
 - c. Insert the supply between the label sensors.
 - d. Feed the supply to the label exit or platen as shown below, and push the inside edge of the supply against the back wall.

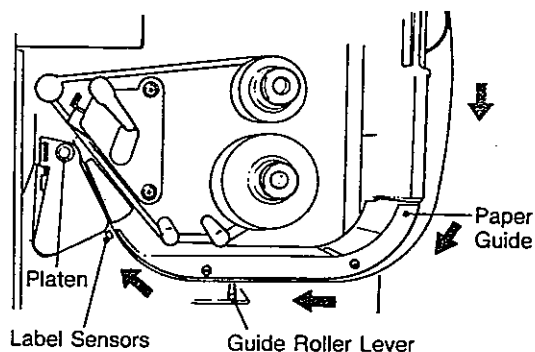

Figure 4-11.

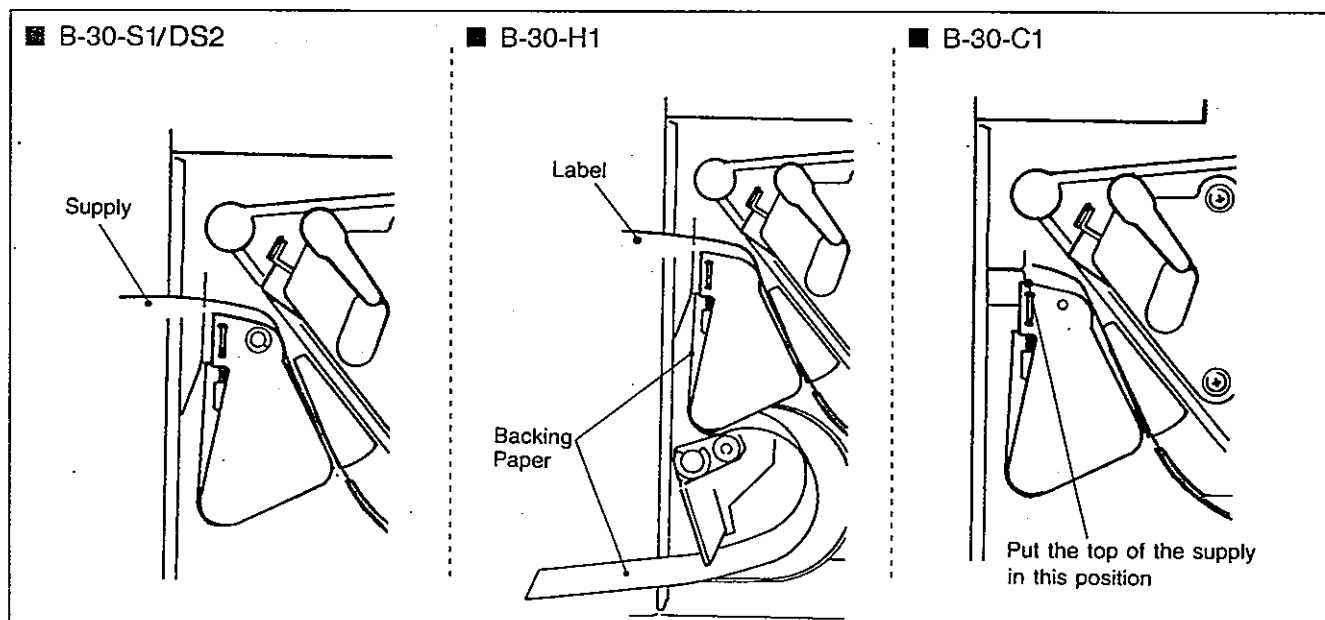

Figure 4-12.

6. Move the head lock lever to position 1 or 2 according to the thickness of the supply.

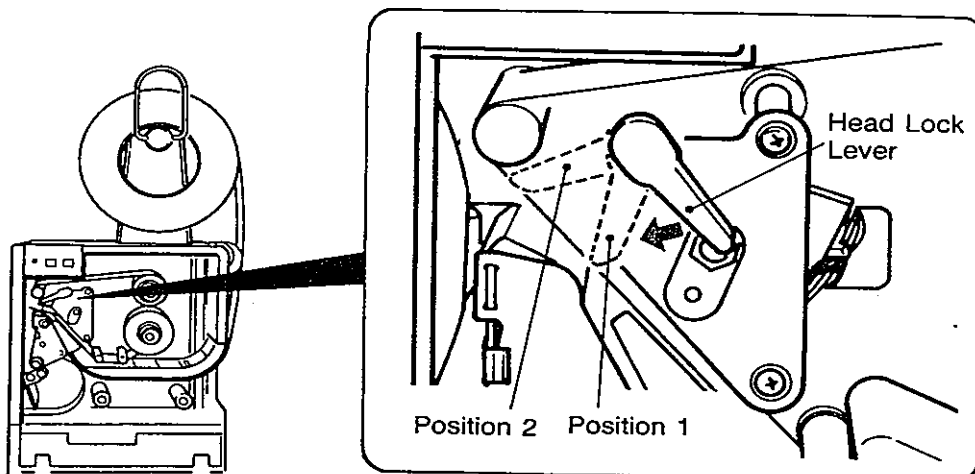

Figure 4-13. Position 1: Thin paper
Position 2: Thick paper

7. Close the front door.

2.2. For B-30-S2/H2/C2/S3/H3/C3/AS2/AS3/AH3

The printer prints both tags and labels.

1. Turn the power off.
2. Place the supply roll onto the supply roll holder.
3. Open the front door.
4. Move the head lock lever to the right to release the print head.

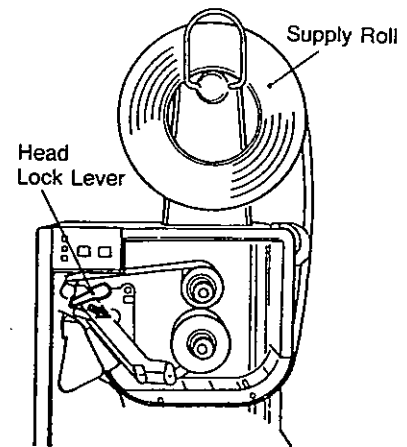

Figure 4-14.

5. Press down the roller open lever to release the skew roller.

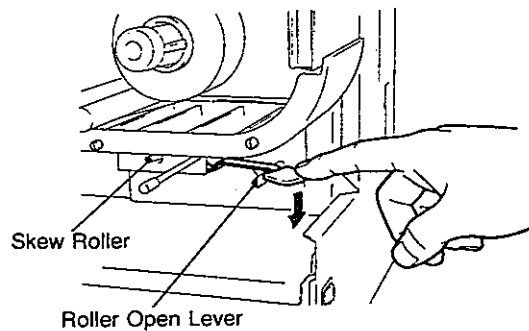

Figure 4-15.

6. Thread the supply as shown.
 - a. Pull enough supply out from the roll to reach the paper setting zone.
 - b. Slide the supply under the paper guide, and push the inside edge of the supply against the back wall.

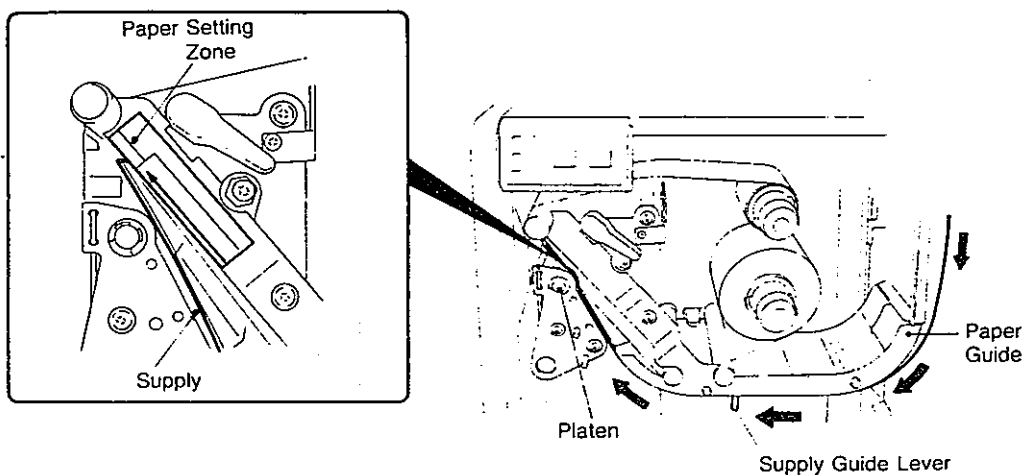

Figure 4-16.

7. Push the roller close lever.

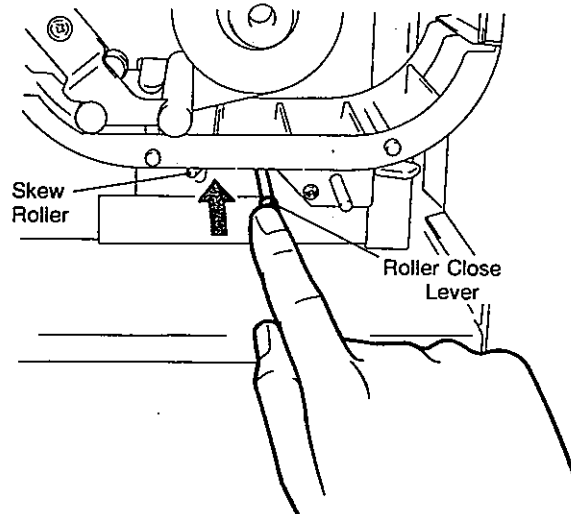

Figure 4-17.

8. Move the head lock lever to position 1 or 2 according to the thickness of the supply.

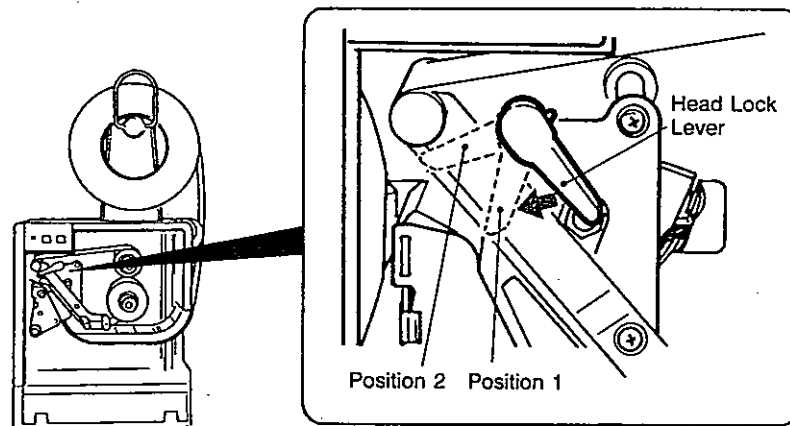

Figure 4-18. Position 1: Thin paper
Position 2: Thick paper

9. Close the front door.

2.3. For B-30-S5/AS5

The printer prints both tags and labels.

1. Turn the power off.
2. Place the supply roll onto the supply roll holder.
3. Open the front door.
4. Move the head lock lever to the right to release the print head.

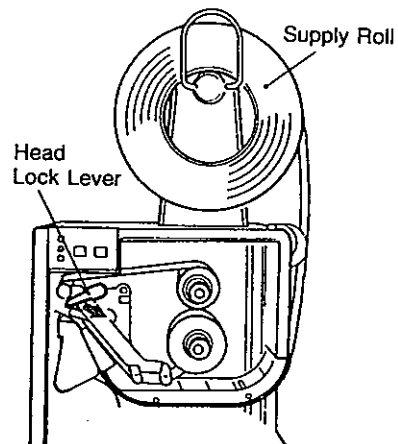

Figure 4-26.

5. Thread the supply as shown.
 - a. Pull enough supply out from the roll to reach the paper setting zone.
 - b. Slide the supply under the paper guide, and push the inside edge of the supply against the back wall.

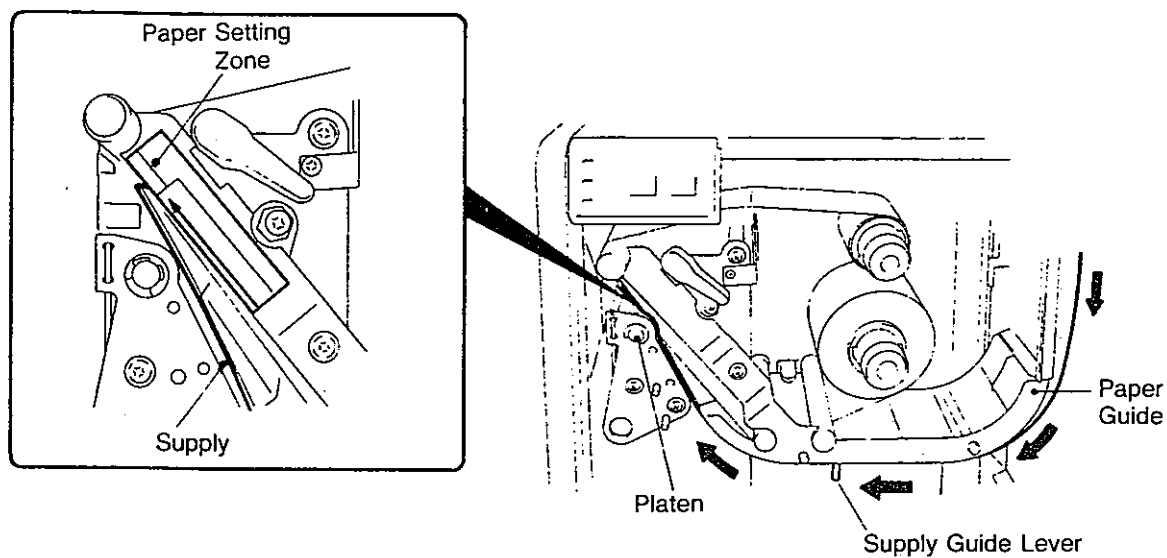

Figure 4-27.

6. Move the head lock lever to position 1 or 2 according to the thickness of the supply.

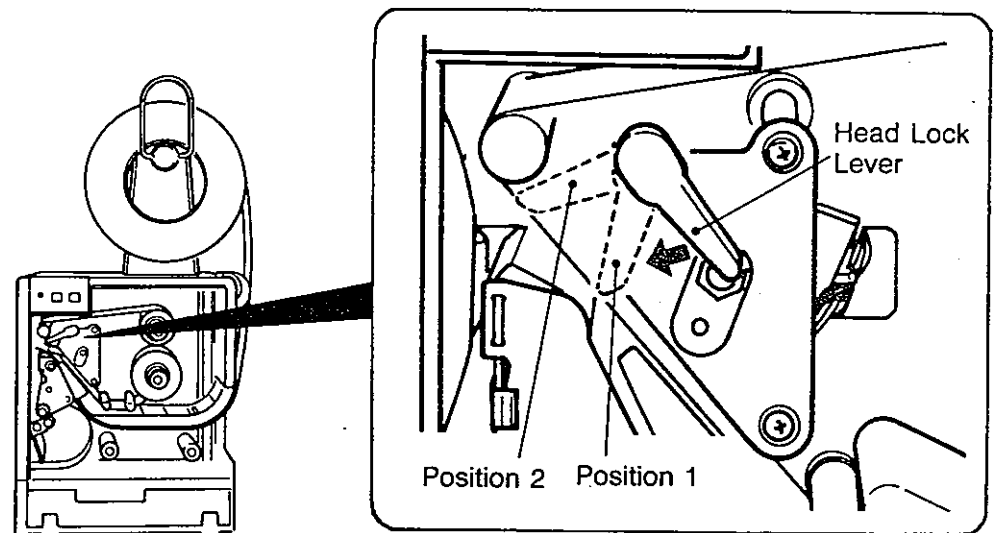

Figure 4-28. Position 1: Thin paper
Position 2: Thick paper

7. Use the supply guide lever to fit the supply guide to the supply.

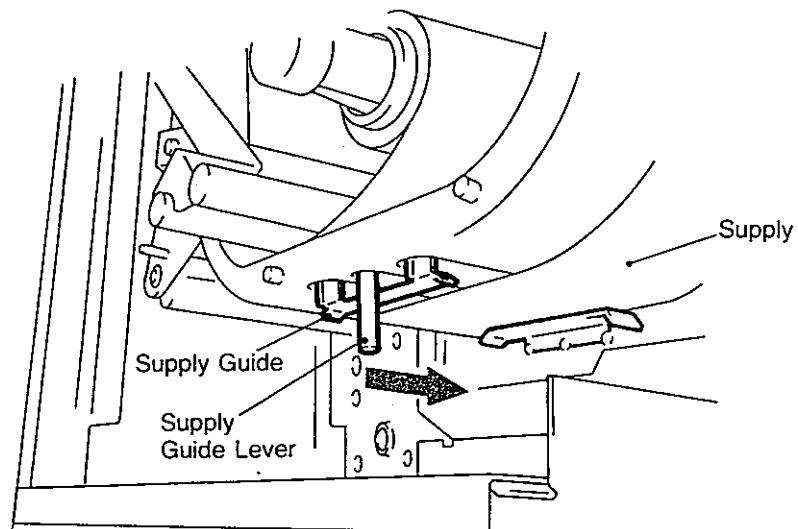

Figure 4-29.

8. Close the front door.

■ Threading the backing paper (B-30-AH3 and B-30-H3/S3/AS3/S5/AS5 with Rewinder unit)

To rewind backing paper in the on-demand printing mode, thread the backing paper shown below.

1. Pass the backing paper under the guide rollers.
2. Secure the backing paper to the rewind shaft with clamp.

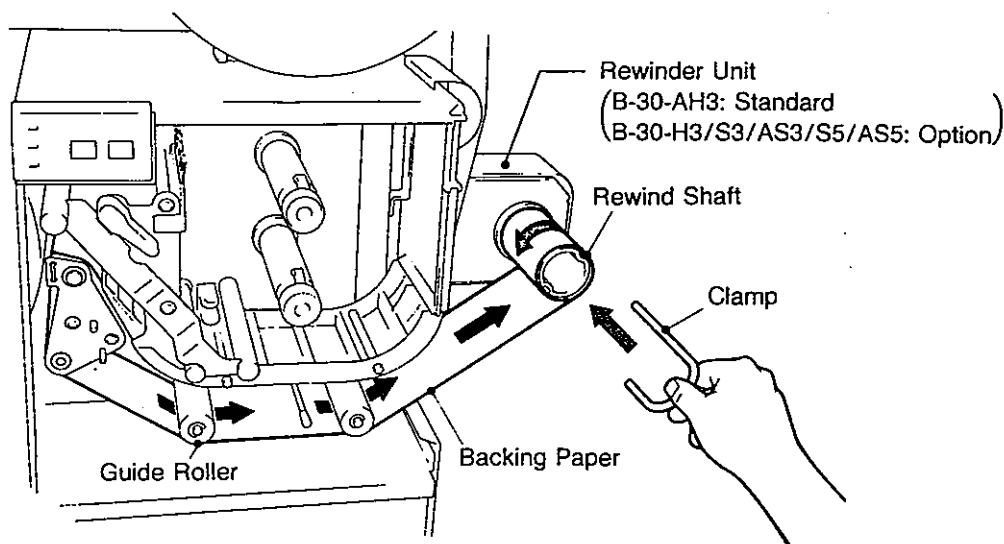

Figure 4-19.

3. INSERTING THE MEMORY CARD

1. Turn the power off.
2. Insert the memory card with preregistered print data into the memory card slot.
3. To prevent the memory card from being removed accidentally, be sure to attach the memory card cover.

WARNING: Replace battery with Hitachi Maxell Ltd., type CR2016 only. Use of another battery may present a risk of fire or explosion.

WARNING: A battery may explode if handled improperly. **DO NOT** recharge, disassemble or dispose of in fire.

NOTICE: The data is protected by a backup battery which is installed inside the memory card. The service life of the battery is eighteen (18) months. To replace the battery, consult your TEC dealer or service representative. If the memory card is used with an expired battery, correct operations are not guaranteed by TEC.

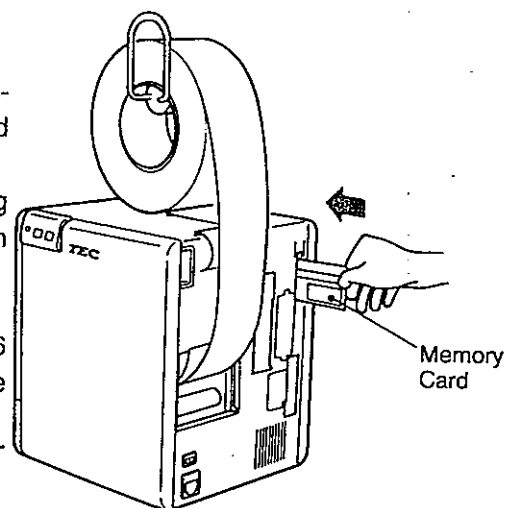

Figure 4-20.

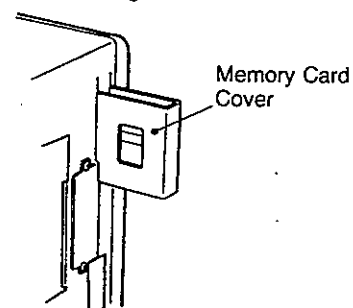
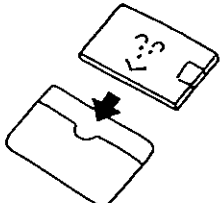
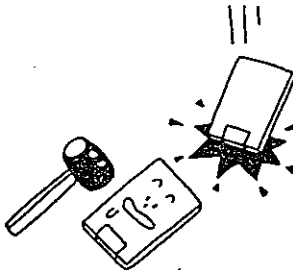
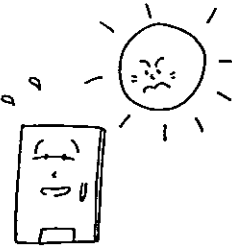
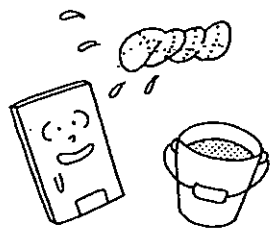
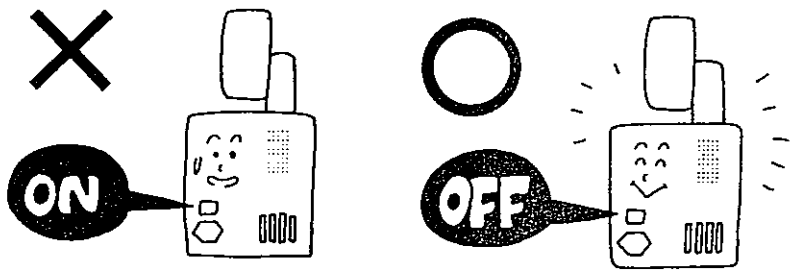

Figure 4-21.

■ PRECAUTIONS

| | |
|---|---|
| <p>Be sure to protect a memory card by inserting it into its protective cover.</p>  | <p>Do not apply a shock or excessive force to the memory card.</p>  |
| <p>Do not allow any memory card to be exposed to excessive heat by leaving it in sunlight or bringing it close to a heater.</p>  | <p>Do not expose any memory card to excessive humidity by wiping it with a wet cloth or leaving it in a damp place.</p>  |
| <p>Before inserting or removing the memory card, be sure to check that the POWER switch is turned OFF.</p>  | |

4. ADJUSTING THE SENSORS

The sensors detect black marks or feed gaps. The adjustment shafts move the sensors in and out.

4.1. Black Mark or Feed Gap Sensor

Adjust the position of the sensor according to the length, from the left end of the supply to the black mark or from the center of the feed gap.

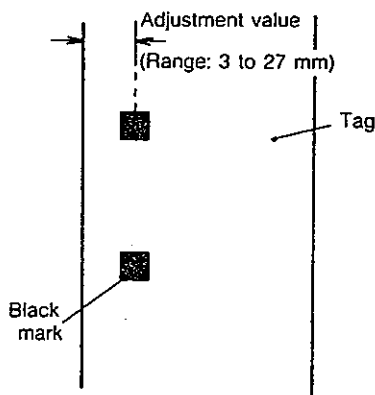
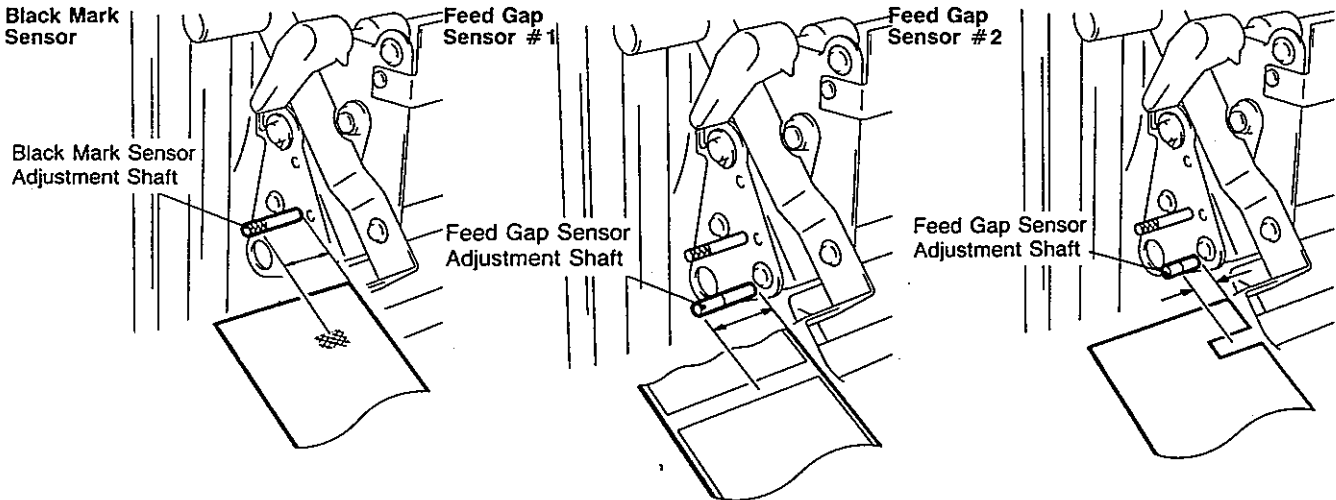

Figure 4-22.

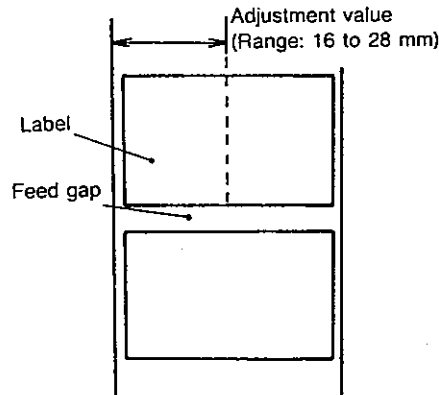

Figure 4-23.

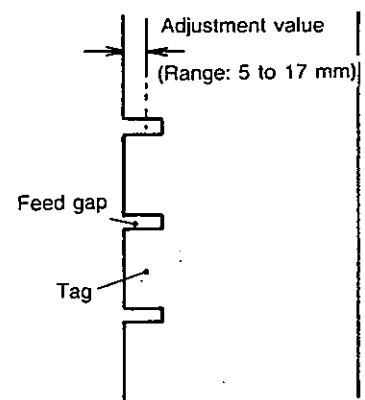

Figure 4-24.

NOTICE: Which sensor is used depends on the conditions of supply.

4.2. Label Issue Sensor (for On-demand type)

Adjust the position of the label issue sensor to the blank portion of the issued label (the portion where no characters are printed).

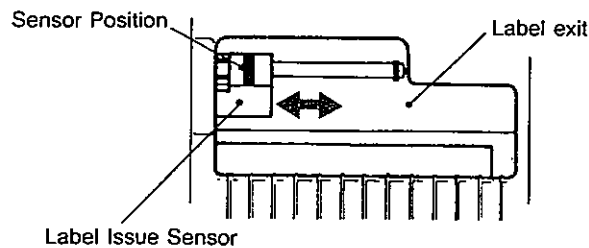

Figure 4-25.

CHAPTER 5

MAINTENANCE

| | |
|--------------------------------------|-----|
| 1. REMOVING JAMMED SUPPLIES | 5-1 |
| 1.1. For Standard Type | 5-1 |
| 1.2. For On-demand Type..... | 5-1 |
| 1.3. For Cutter Type..... | 5-2 |
| ■ When the supply is exhausted | 5-2 |
| 2. CLEANING THE PRINT HEAD | 5-3 |
| 3. CLEANING THE CUTTER | 5-4 |
| 4. TROUBLESHOOTING | 5-5 |

1. REMOVING THE JAMMED SUPPLIES

1.1 For Standard Type

1. Open the front door.
2. Move the head lock lever to the right to release the print head.
3. Remove the supplies jammed inside.

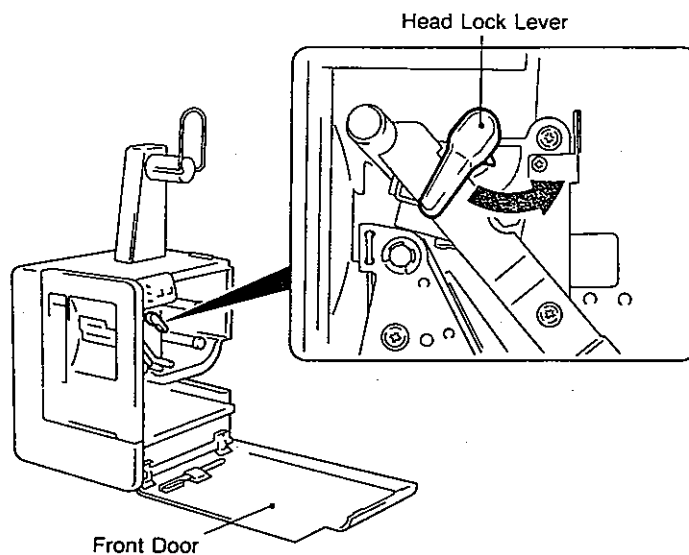

Figure 5-1.

1.2. For On-demand Type (for B-30-H1/H2 only)

1. Open the front door.
2. Move the head lock lever to the right to release the print head.
3. Turn and hold the backing roller lever, and pull the backing paper.

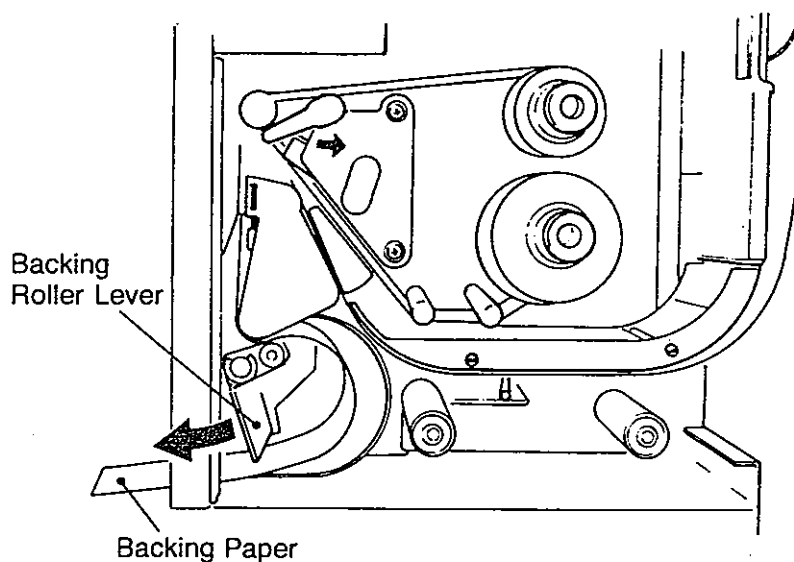

Figure 5-2.

1.3. For Cutter Type

1. Pull out the lock knob and adjustment knob.
2. Pull at the upper side of the cutter cover to remove it.

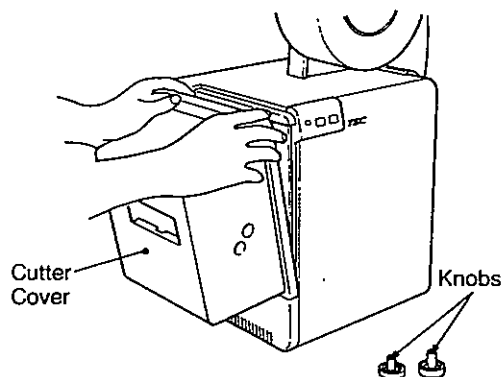

Figure 5-3.

3. Remove screw (A) to take out the supply guide cover, then remove the supplies jammed (blocking) inside.

WARNING: Turn the power off before removing jammed supplies.

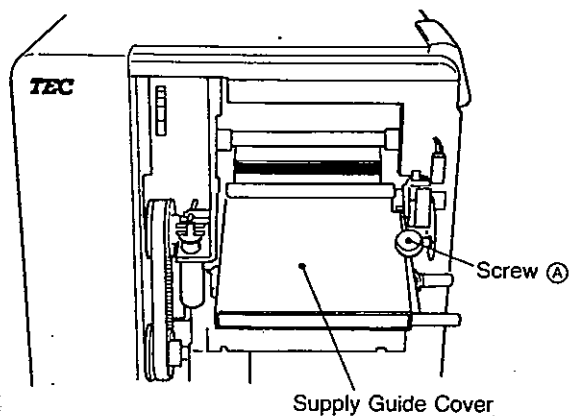

Figure 5-4.

■ When the supply is exhausted

1. Depress the FEED key.
2. Pull out the piece of paper remaining in the cutter unit using tweezers.

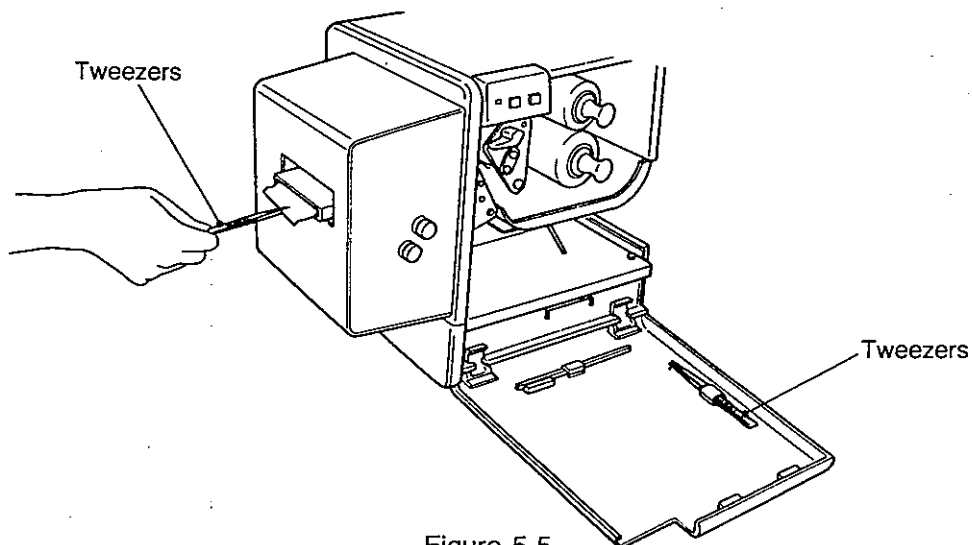

Figure 5-5.

2. CLEANING THE PRINT HEAD

If the print head is dirty, clear printing is not performed.

It is recommended to clean the head with thermal head cleaner before loading a new ribbon.

1. Turn the power off.
2. Open the front door.
3. Move the head lock lever to the right to release the print head.
4. Remove the ribbon if it has been loaded.
5. Move the supply back past the top of the paper guide.

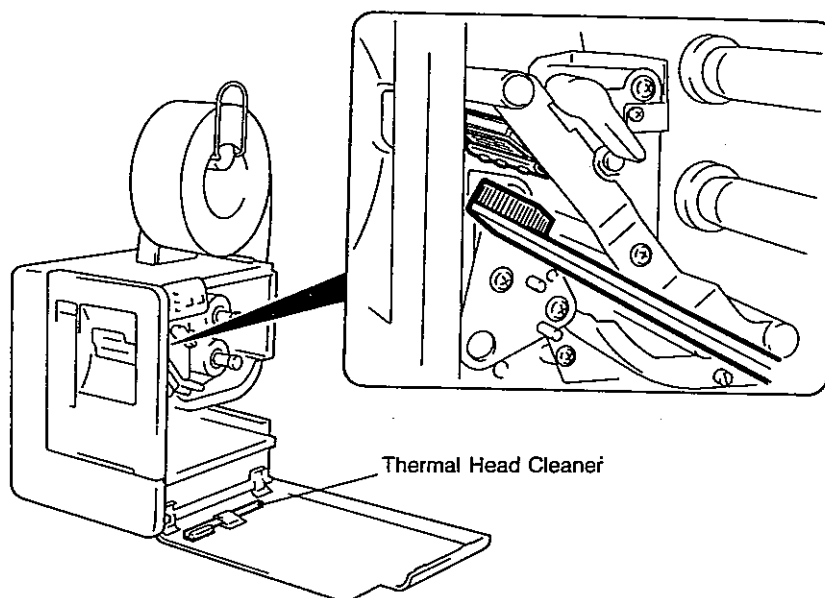

Figure 5-6.

6. Rub back and forth across the print head using thermal head cleaner.
7. Reload the supply and/or ribbon.

WARNING: Turn the power off before cleaning the print head.

WARNING: Be careful **NOT TO DAMAGE** the print head when cleaning.

3. CLEANING THE CUTTER

WARNING: Turn the power off before cleaning the cutter.

WARNING: Be extremely careful **NOT TO CUT** your fingers.

1. Pull out the lock knob and adjustment knob.
2. Pull the upper section of the cutter cover toward you to remove the cover.
3. Remove screws (A) to remove the supply guide cover.
4. Clean "dust" on the cutter with a soft cloth moistened with alcohol.

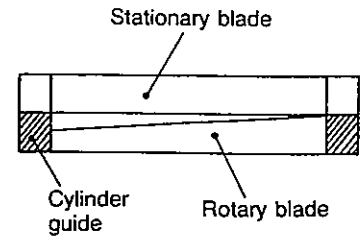

Figure 5-7.

WARNING: At this time, **DO NOT WIPE OFF** the cylinder guides (hatched parts) at both ends of the cutter.

5. If the rotating noise of the blade becomes particularly great, apply grease using a soft cloth. (Excessively applied grease may stain the supplies.) Grease should be applied to the rotary blade, stationary blade, and cylinder guides. For the cylinder guides (hatched parts), apply grease to their exposed parts so that grease spreads all around when the blade turns.

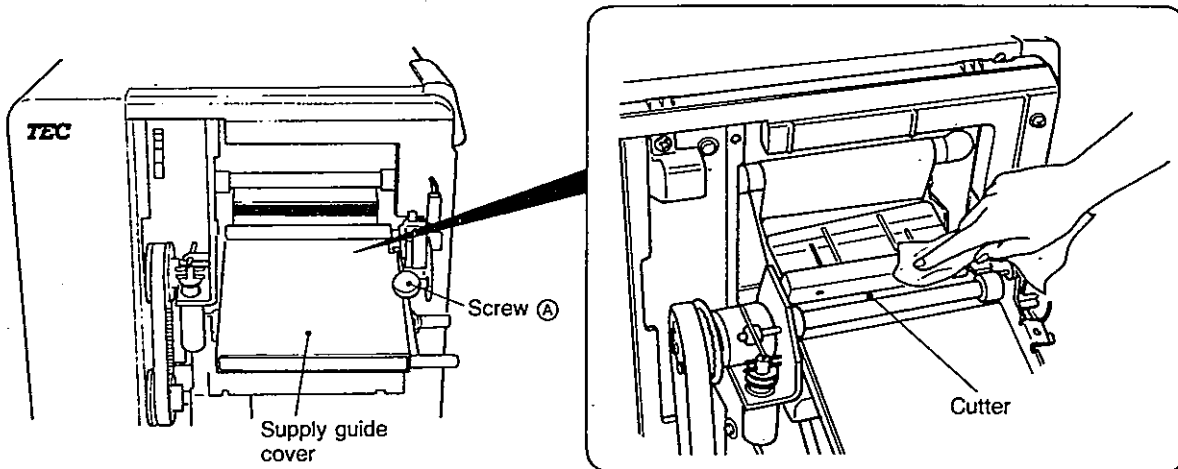

Figure 5-8.

● Cutter Life

Observe raised nap on the cut end of the supply to determine whether the cutter has worn out. The life of a cutter largely varies according to the material, thickness, and kind of supply.

ex.)

Good

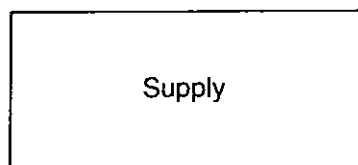

No good

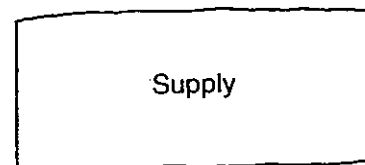

If the cut end of the supply is no longer straight as shown above, contact your TEC representative.

4. TROUBLESHOOTING

It is our primary concern to give you full satisfaction and better service.

If, however, any problem arises in connection with the operation of this printer, please check the following points before you call for service.

| Error Message | Problem | Solution |
|---|---|---|
| SENSOR OR LENGTH ERROR | <ol style="list-style-type: none"> 1. The paper is not placed correctly. 2. The feeding paper is jammed and does not feed smoothly. 3. The black mark or feed gap sensor position is incorrect. 4. The combination of the issuing condition and paper or sensor does not match. | <ol style="list-style-type: none"> 1. Place the paper correctly. → Press PAUSE key. 2. Remove the jammed paper and place the undamaged paper correctly. → Press PAUSE key. 3. Adjust the sensor position. → Press PAUSE key. 4. Select the paper or sensor matching the issuing condition. → Press PAUSE key. |
| NO PAPER | The supply ran out. | Load a new supply. → Press PAUSE key. |
| NO RIBBON | The ribbon ran out. | Load a new ribbon. → Press PAUSE key. |
| HEAD OPEN | When the print head is not set correctly, the supply tries to feed or issue. | Set the print head correctly. → Press PAUSE key. |
| CUTTER JAMMED (for Cutter type only) | <ol style="list-style-type: none"> 1. The paper is not cut correctly. 2. The supply is jammed in the cutter unit. | <ol style="list-style-type: none"> 1. Set the cutter at the home position. → Press PAUSE key. 2. Open the cutter cover and remove the jammed (blocking) supply. → Press PAUSE key. |
| CUTTER COVER OPEN (for Cutter type only) | <ol style="list-style-type: none"> 1. The cutter cover is not closed firmly. 2. The cutter is not at the home position. | <ol style="list-style-type: none"> 1. Close the cutter cover securely. → Press PAUSE key. 2. Set the cutter at the home position. → Press PAUSE key. |
| MISSING FEED KEY ERROR | After replacing with a new supply, the supply tries to issue one time without feeding. | Change the issuing condition for a new supply. → Turn off the power and then turn it on again. |
| COMMUNICATION ERROR (except for B-30-S1/H1/C1) | Error has occurred in communicating with a personal computer. | Turn off the power and then turn it on again. |
| <p>NOTE: When an error is not cleared by pressing the PAUSE key, turn off the power and then turn it on again. When the power is turned on again, print data to be issued is cleared.</p> | | |

| Problem | Solution |
|--|---|
| No print. | <ol style="list-style-type: none">1. Check whether the supply or ribbon is loaded correctly or not.2. Check whether the print head is set correctly or not.3. Check whether the memory card is inserted correctly or not.4. Check whether the interface cable is connected correctly or not. |
| Printed characters are unclear (or blurred). | <ol style="list-style-type: none">1. Dirty print head. → Clean the print head.2. Bad ribbon. → Change to new ribbon.3. Wrong supply for printing. → Change to new supply. |
| Power is not turned ON. | <ol style="list-style-type: none">1. Insert the power plug into the AC outlet firmly.2. Check the circuit breaker.3. Check whether the printer fuse is blown or not. |

This printer has been manufactured under strict quality control. If you have any trouble, however, DO NOT ATTEMPT TO FIX IT BY YOURSELF. Turn the power off, pull the power plug out of the AC outlet, and contact your TEC representative.

TEC
TOSHIBA TEC CORPORATION

英文

 PRINTED IN JAPAN
EM1-33004D.9404400 ①

Free Manuals Download Website

<http://myh66.com>

<http://usermanuals.us>

<http://www.somanuals.com>

<http://www.4manuals.cc>

<http://www.manual-lib.com>

<http://www.404manual.com>

<http://www.luxmanual.com>

<http://aubethermostatmanual.com>

Golf course search by state

<http://golfingnear.com>

Email search by domain

<http://emailbydomain.com>

Auto manuals search

<http://auto.somanuals.com>

TV manuals search

<http://tv.somanuals.com>