

TEC

TEC Bar Code Printer

B-411 SERIES

Owner's Manual

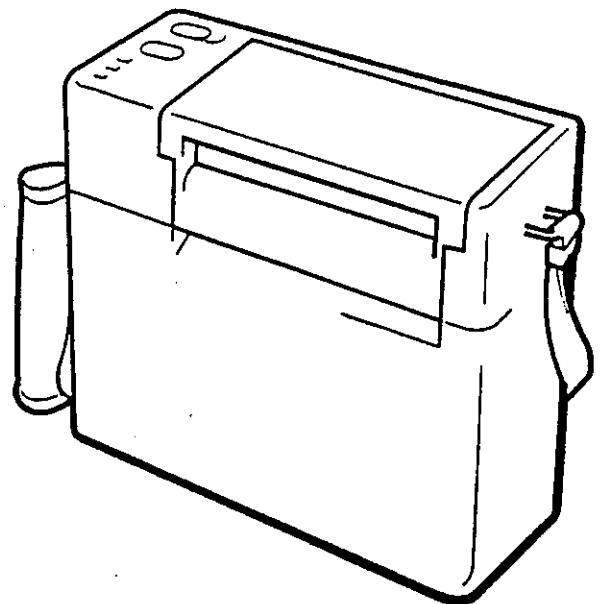

TOKYO ELECTRIC CO., LTD.

TABLE OF CONTENTS

	Page
INTRODUCTION	1
PRECAUTIONS	1
APPLICABLE MODEL	1
1. SPECIFICATIONS	2
1.1 PRINTER	2
1.2 PAPERS	2
1.3 INTERFACE	2
1.4 BATTERY CHARGER	3
1.5 DIMENSIONS	3
2. OVERVIEW	4
2.1 FRONT VIEW	4
2.2 REAR VIEW	4
2.3 OPERATION PANEL	5
3. INSTALLING THE PRINTER	5
3.1 HOW TO INSTALLING AND ADJUST THE SHOULDER STRAP	5
3.2 REPLACING AND INSTALLING THE BATTERY	6
3.3 CHARGING THE BATTERY	6
4. LOADING PAPERS	7
5. REMOVING THE JAMMED PAPERS	9
6. CLEANING	10
6.1 THERMAL HEAD/PLATEN/PINCH ROLLER	10
6.2 COVERS/PANELS	10
7. SELECTING A DATA TRANSMISSION SPEED	11
8. TROUBLESHOOTING	12

INTRODUCTION

Thank you for choosing the TEC Bar Code Printer B-411 Series. The B-411 has been developed for issuing various kinds of bar codes. The B-411 adopts a state of the art thermal printer so that it produces less noise and more clearly printed characters.

This manual contains information about the general set-up and maintenance of the B-411 printer, and should be read carefully to obtain maximum performance from your printer. Since ample consideration has been given to safety, there is no danger of damaging the printer by erroneous operation.

Should you have any questions concerning the printer, please refer to this manual. Be sure to keep this manual for future reference.

PRECAUTIONS

1. Clean the cover by wiping with a dry cloth or a cloth soaked with detergent and thoroughly wrung out. NEVER USE THINNER OR OTHER VOLATILE SOLVENT for cleaning.
2. DO NOT POUR WATER directly on the printer.
3. When in use, avoid locations subject to vibration and direct sunlight.
4. Properly use the TEC-specified labels.
5. DO NOT STORE the labels, in locations exposed to direct sunlight, high temperature, high humidity, dust, or gas.

APPLICABLE MODEL

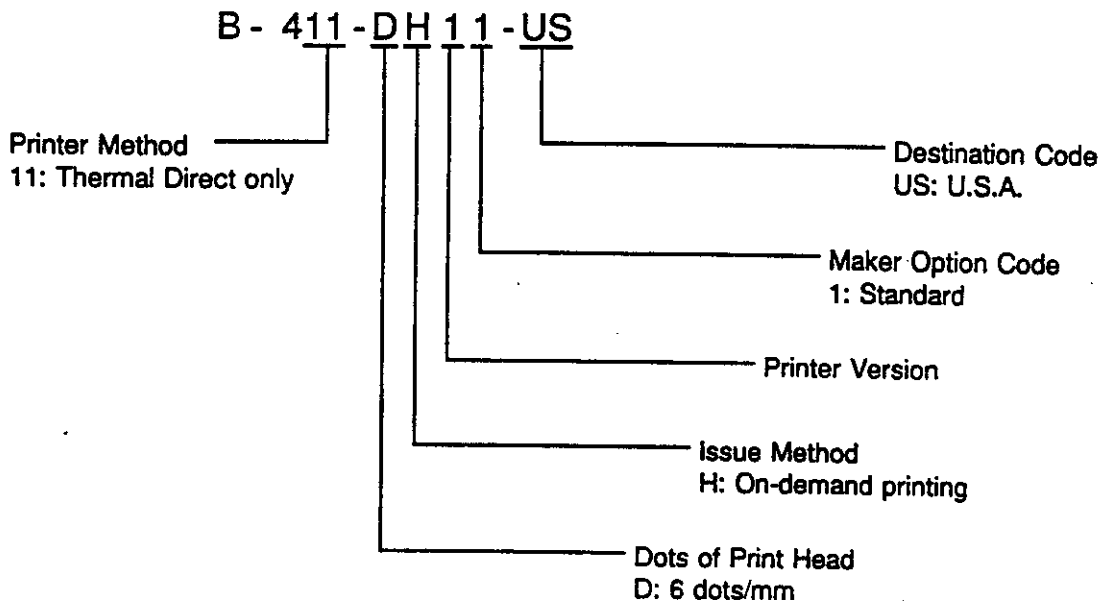

1. SPECIFICATIONS

1.1 PRINTER

Item \ Model	B-411
Power Requirement	Ni-Cd battery (DC 13.2V) Capacity: 19.7mm (500") or 1.4AH Charging time: 7~8AH (Rechargeable a minimum of 300 times)
Temperature Limits	5°C to 40°C (41°F to 104°F)
Relative Humidity	25% to 85% RH (no condensation)
Print Head	Thermal Print Head (6 dots/mm)
Printing Method	Thermal Direct
Print Speed	25.4mm (1")/sec.
Available Printing Width	46.8mm (1.84"), 72.2mm (2.84"), 97.6mm (3.84")
Bar Code Format	Codabar, ITF, CODE39 Parallel only (Barcode height is less than 139 dots)
Type Fonts	Standard 1 (8×18) dots Standard 2 (16×24) dots Bold 1 (8×18) dots Bold 2 (16×24) dots 3/4" character (38×75) dots Graphic Font (8×12) dots
Interface	Serial interface (RS-232C)

1.2 PAPERS

Item \ Paper Type	Thermal Paper (Label)
Width	53.8mm (2.12"), 79.2mm (3.12"), 104.6mm (4.12")
Length (Pitch)	Max. 998mm (Max. 39.3")
Thickness	0.14mm~0.15mm (0.0055"~0.0059")
Roll Diameter	52mm (2.04") max.

1.3 INTERFACE

Item \ Interface	Electronics specification
Baud rate	RS-232C 9600bps or 19200bps
Protocol	XON/XOFF, 8 bit Data, Non Parity, Stop bit = 2 bit
Signal	TXD, RXD, RTS, CTS

1.4 BATTERY CHARGER

Use a battery charger having the following specifications.

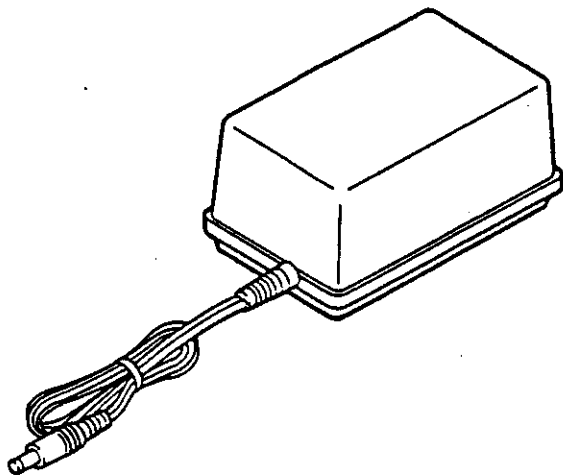

Item	Specification
Input Voltage	AC120V \pm 10%
Output Voltage	DC16.0V
Safety Standard	Complying with UL and CSA
Charging Time	8 hours \pm 10% (13.2V 1.4AH Battery)

1.5 DIMENSIONS (APPROXIMATE)

Weight: 1.7kg (3.74 lbs.)

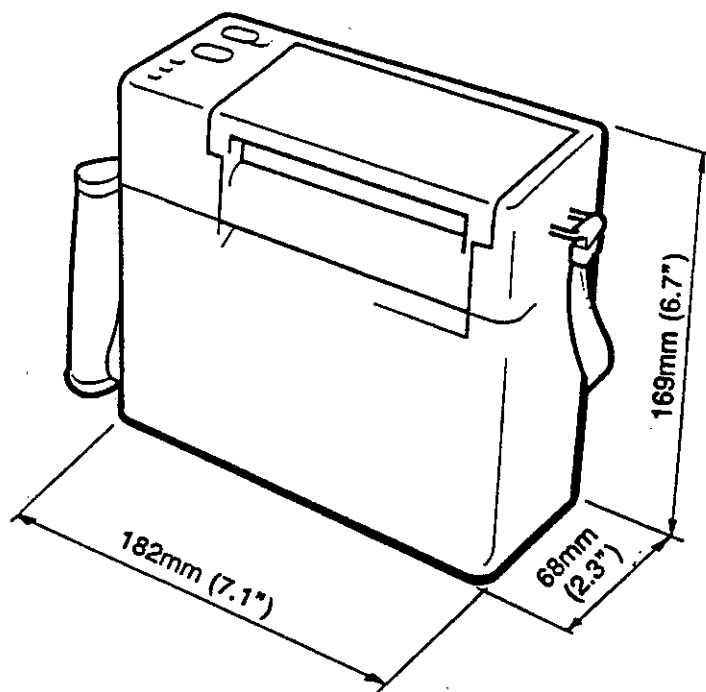

2. OVERVIEW

2.1 FRONT VIEW

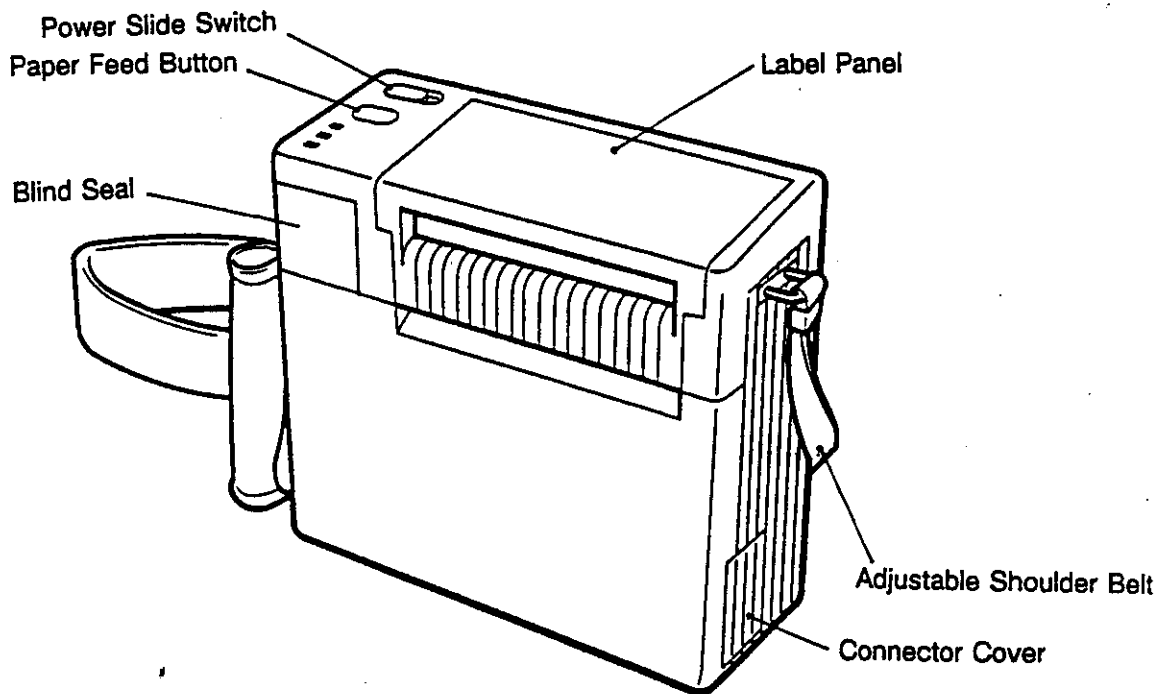

2.2 REAR VIEW

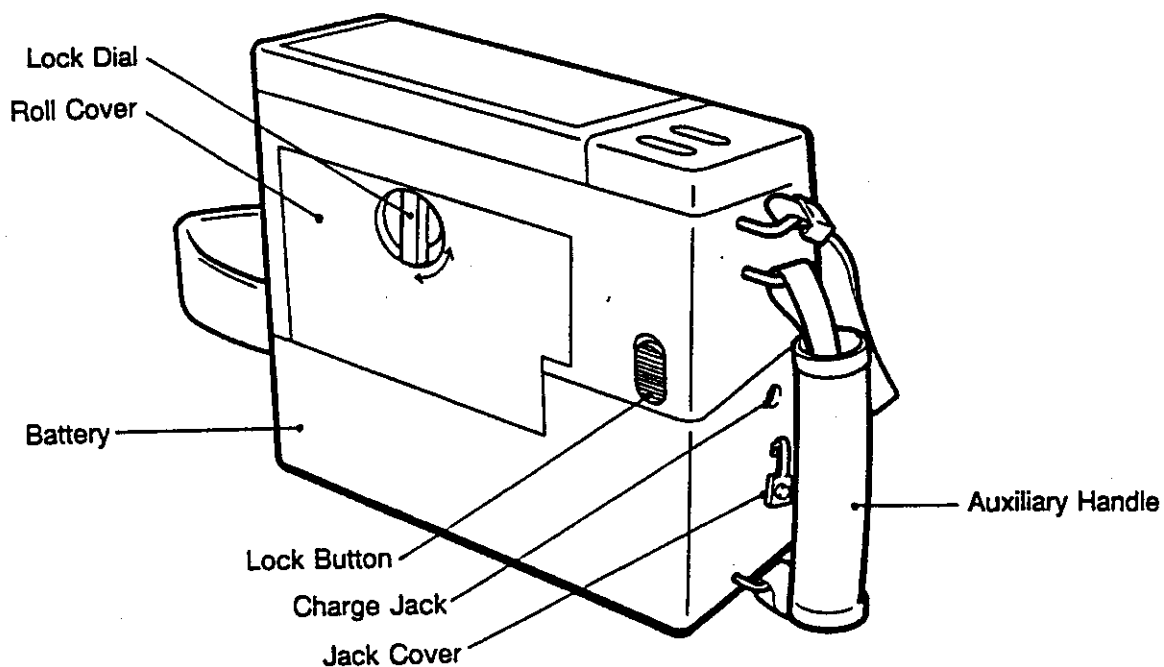

2.3 OPERATION PANEL

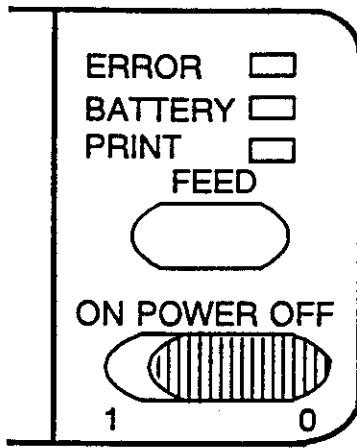

ERROR Indicator (Green)

Lights when the printer does not operate correctly.

BATTERY Indicator (Orange)

Lights when the battery voltage drops. (Replace the battery)

PRINT Indicator (Green)

Lights for one second when the power is turned ON.

Lights while printing or issuing labels.

FEED Button

This button is used to feed the labels.

POWER Slide switch

Power supply switch for the printer.

3. INSTALLING THE PRINTER

3.1 HOW TO INSTALLING AND ADJUST THE SHOULDER STRAP

Pass the end of the Shoulder Strap through the tab of the printer from the inside, then pass it through parts A, B and C as shown in the figure. After adjusting the length of the strap, insert the loose end of the strap into the shoulder pad.

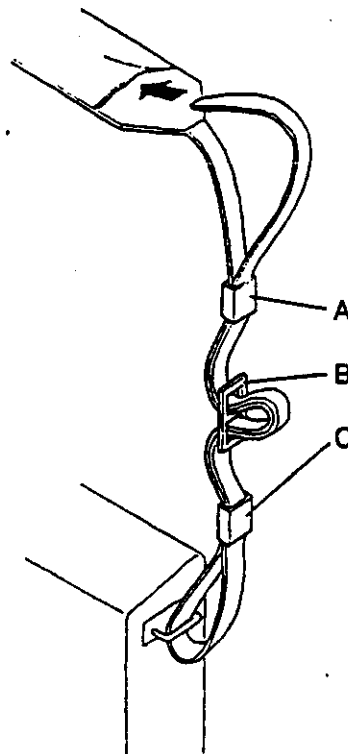

3.2 REPLACING AND INSTALLING THE BATTERY

To replace the battery:

If the Battery Indicator on the operation panel lights, turn the power OFF, pull up the lock button, slide the battery to the right to remove it. Replace the battery.

To install the battery:

Align the left edge of the battery with the line of part A, and slide the battery to the left to lock it in place. (At this time, push the battery until a click is heard from the lock button.)

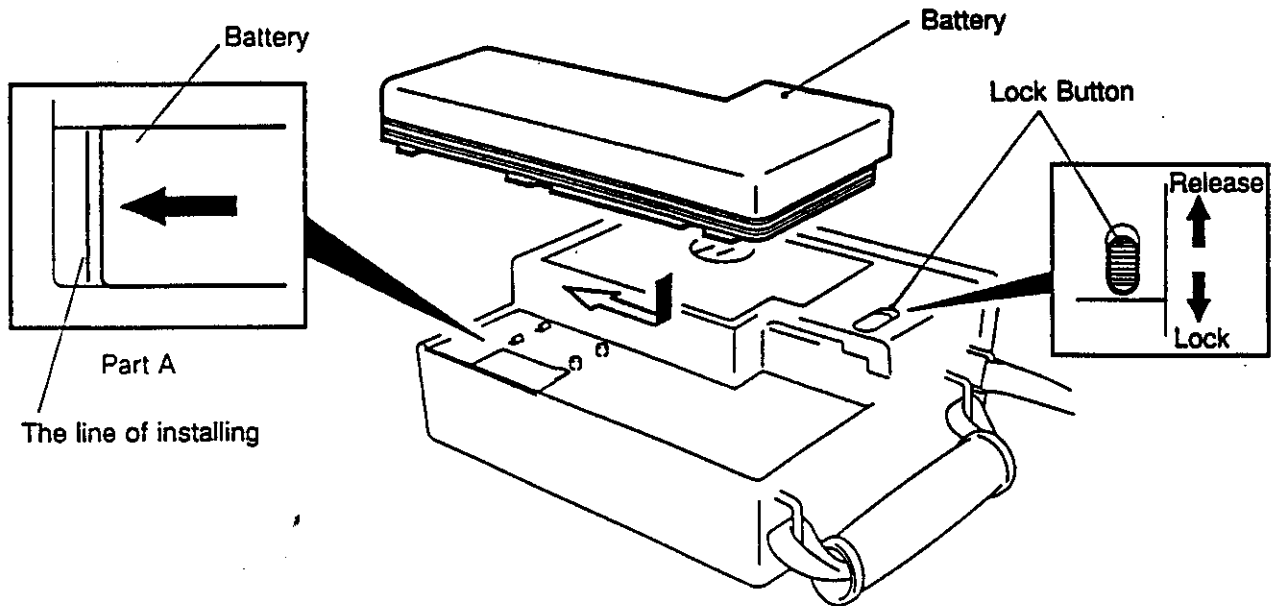

3.3 CHARGING THE BATTERY

Turn OFF the printer power. Open the jack cover and connect the battery charger plug to the printer. It requires 8 hours to charge the battery.

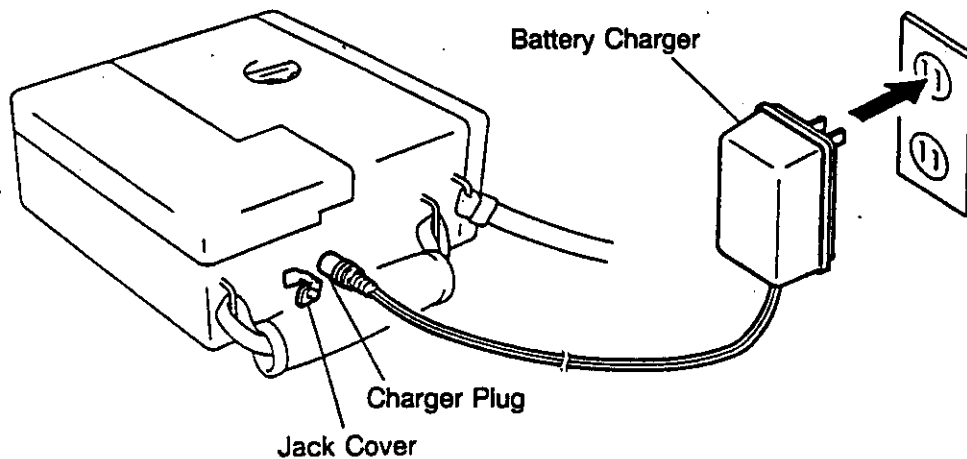

4. LOADING PAPERS

The printer prints labels of the thermal paper.

- 1) Turn the power off and open the label panel and roll cover.

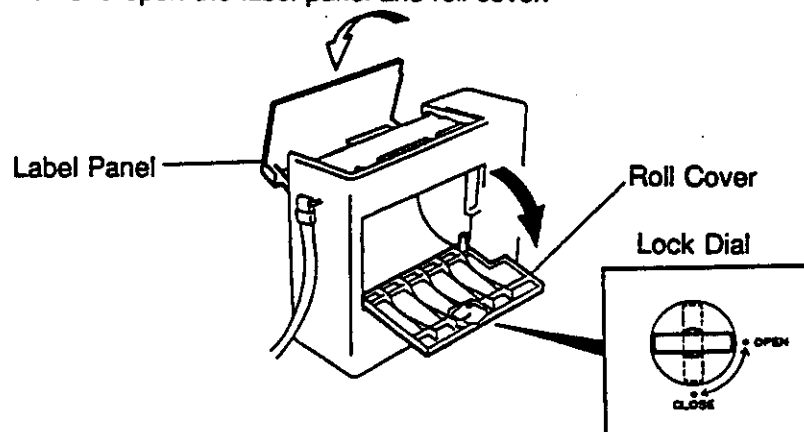

- 2) Load the roll paper and pass the leading part of the paper into the printer.

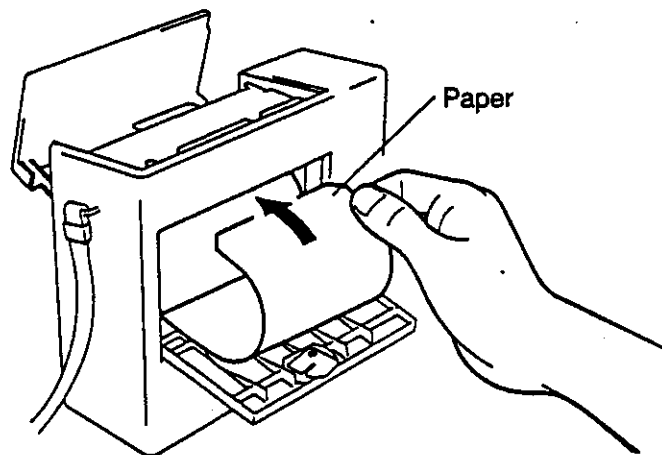

- 3) Lift the print head and pull out the paper.

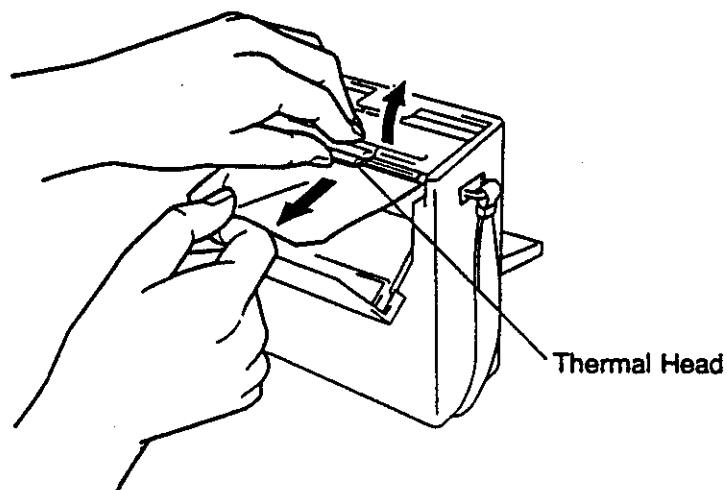

CAUTION: Use only designated paper, or trouble may result.

- 4) Push down the pinch roller lever, pass the paper through the printer, and pull out the paper from under the label panel.

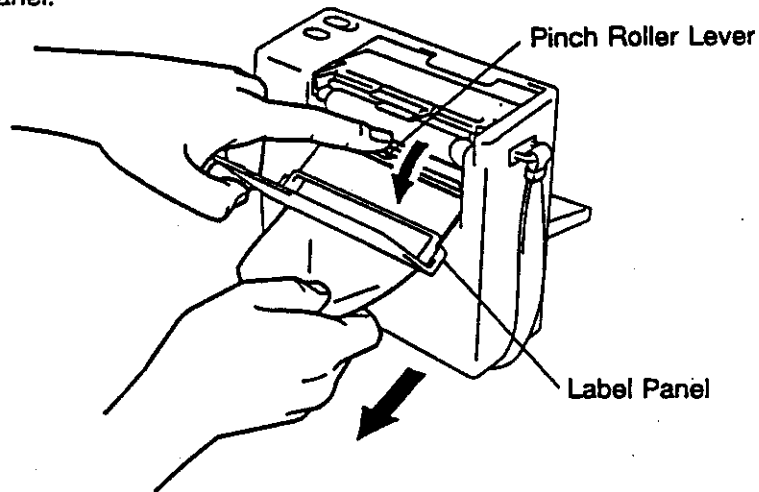

- 5) Align both sides of the paper with the left and right label guides (red marks) of the print head. Make sure that there is no sag between the thermal head and the pinch roller.

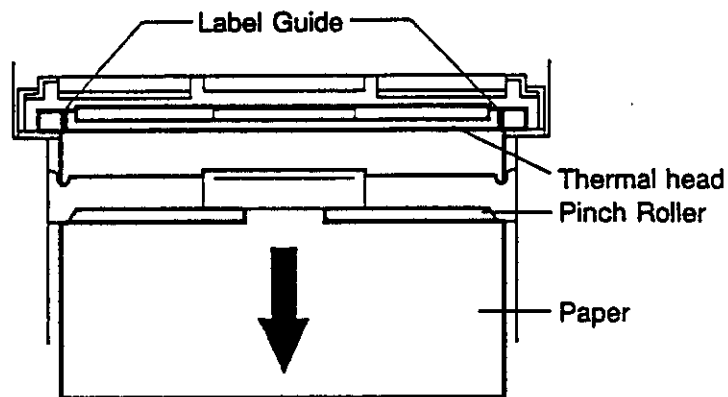

- 6) Close the label panel and roll cover.

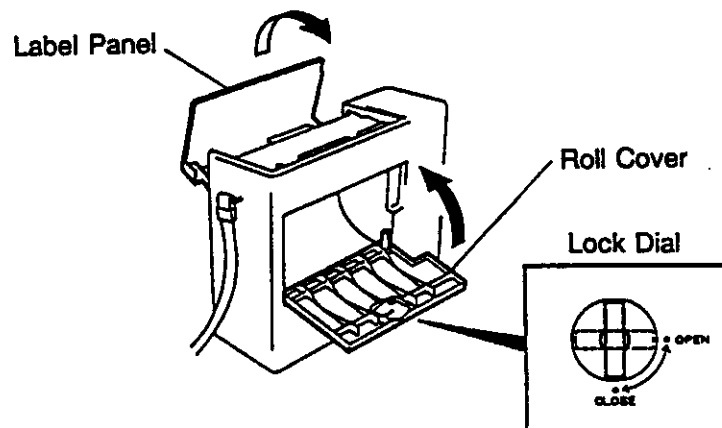

- 7) Turn the power ON and press the FEED button to ensure that the printer operates normally.

CAUTION: After replacing the paper or removing the jammed paper from the printer, the depressing of the FEED button allows the reinserted paper to be automatically fed to the printing position.

5. REMOVING THE JAMMED PAPERS

If a paper jam has occurred while the printer is in use, take the following action.

- 1) Turn the power OFF and open the label panel and roll cover.
- 2) Press down the head release plate and pull it out toward you.

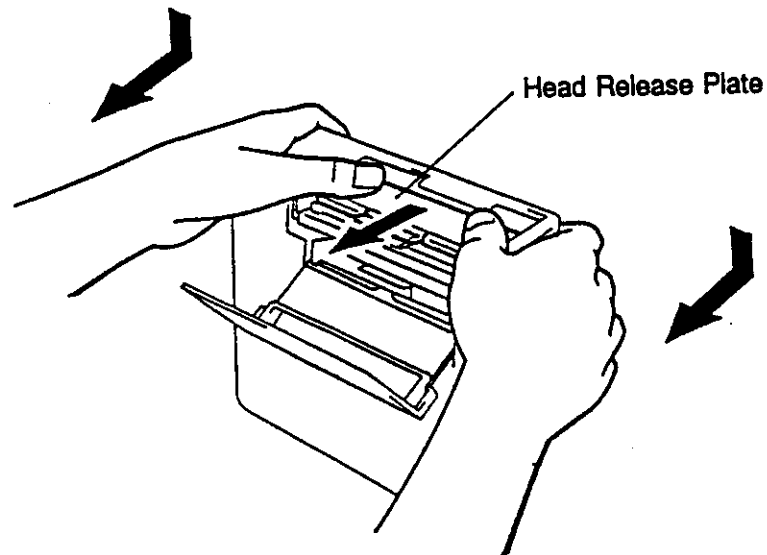

- 3) Lift the thermal head and remove the jammed paper.
- 4) Be sure to clean the print head platen to remove glue from it if any. (Refer to Section 6)

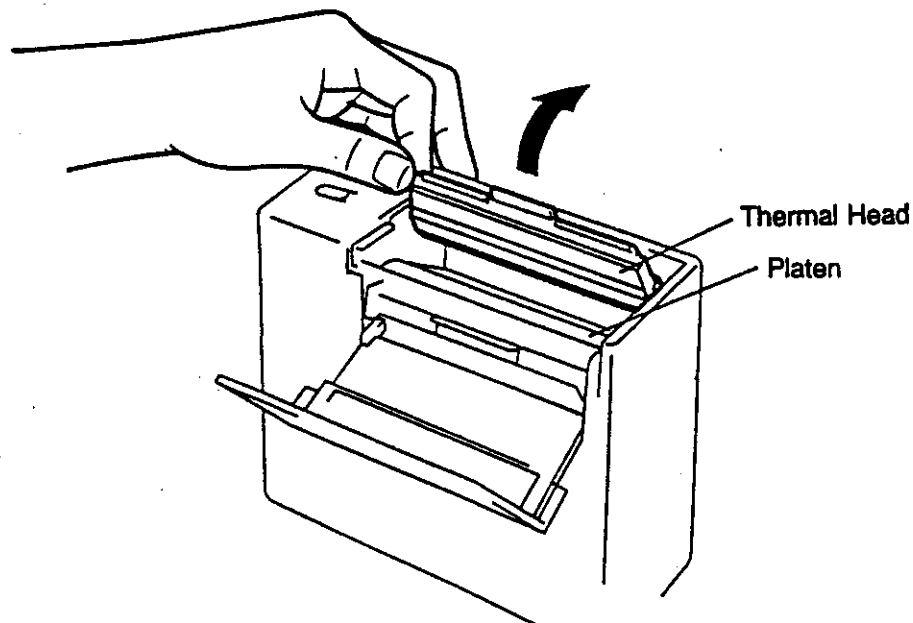

- 5) After removing the jammed paper, install the head release plate in place.

6. CLEANING

6.1 THERMAL HEAD/PLATEN/PINCH ROLLER

Clean the Thermal Head when the followings happen.

- 50 rolls of paper issued.
- Paper jam.
- The paper stained.

Procedure

- 1) Turn the power OFF.
- 2) Open the label panel and remove the head release plate.
- 3) Then clean the print head, platen, and pinch roller with a soft cloth moistened with alcohol.

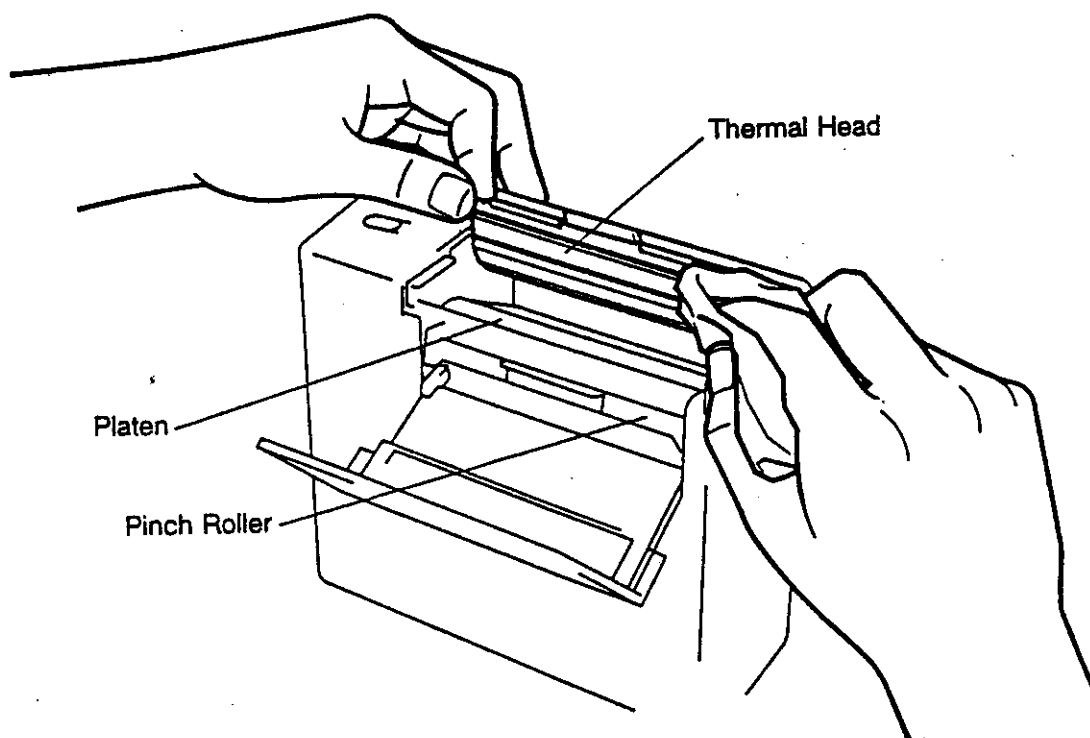

- NOTES:**
- 1) For cleaning, use industrial alcohol which does not contain impurities.
 - 2) Do not clean the covers by alcohol.
 - 3) Do not use any tools which may damage the thermal head.

6.2 COVERS/PANELS

When cleaning the printer surface, use a electrostatic-free cleaner for office automation equipment.

CAUTION: Do not use alcohol for cleaning, or deformation, discoloration or a drop in strength of the covers may result.

7. SELECTING A DATA TRANSMISSION SPEED

In case the data transmission speed of the PC to be connected to this printer is not 9600 BPS, change the speed by following the procedure.

- 1) Turn the power OFF and remove the battery. (Refer to Section 3)
- 2) Remove the DIP switch cover and change the DIP switches as shown below.

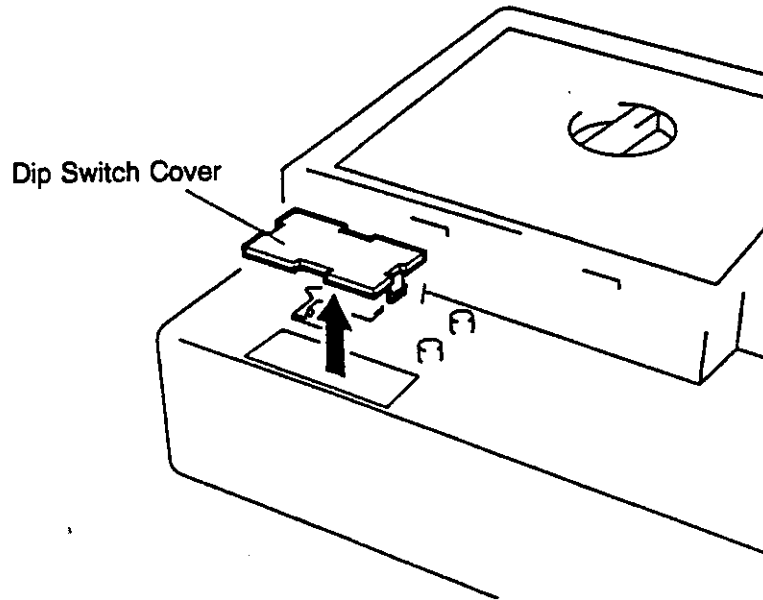

Dip Switch

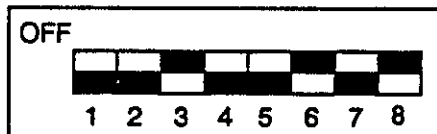

#8 SELECT SENSOR
ON: TRANSMISSIVE SENSOR
OFF: NO SENSOR

#5 RS-232C
ON: 9600BPS
OFF: 19200BPS

WARNING: Do not change any other DIP switches, or a malfunction may result.

8. TROUBLESHOOTING

It is our primary concern to give you full satisfaction and better service. If, however, any problem arises in connection with the operation of this printer, please check the following points before you call for service.

ERROR LED	Problem	Solution
ERROR LED blinks	<ol style="list-style-type: none"> 1. The paper is not placed correctly. 2. The feeding paper is jammed and does not feed smoothly. 3. Installed paper size is different from the programmed paper size. 4. The paper ran out 	<ol style="list-style-type: none"> 1. Place the paper correctly. 2. Remove the jammed paper and place the undamaged paper correctly. 3. Turn off the power and then turn it on again. Set the correct paper size. → Feed the paper. 4. Load a new paper.

Other Problems	Solution
No print	<ol style="list-style-type: none"> 1. Check whether the paper is loaded correctly or not. 2. Check whether the print head is set correctly or not. 3. Check whether the interface cable is connected correctly or not.
Dots missing in print	<ol style="list-style-type: none"> 1. Dirty thermal head. → Clean it by industrial alcohol. (Refer to page 10) 2. Defective thermal head. → Call your representative.
Unclear (of blurred) printing	Dirty thermal head. → Clean the thermal head.
Power is not turned ON.	<ol style="list-style-type: none"> 1. Insert the Battery firmly. 2. Call your representative, if necessary.
Printer trouble	Turn off the power and call your representative.
Error has occurred in communicating with a personal computer	Check the programmed data.
Hardware and/or Software trouble.	Turn off the power and call your representative.

This printer has been manufactured under strict quality control. If you have any trouble, however, **DO NOT ATTEMPT TO FIX IT BY YOURSELF**. Turn the power off, and contact your representative.



TEC
TOKYO ELECTRIC CO., LTD.

E PRINTED IN JAPAN
EM1-33017A 9202300 ①

Free Manuals Download Website

<http://myh66.com>

<http://usermanuals.us>

<http://www.somanuals.com>

<http://www.4manuals.cc>

<http://www.manual-lib.com>

<http://www.404manual.com>

<http://www.luxmanual.com>

<http://aubethermostatmanual.com>

Golf course search by state

<http://golfingnear.com>

Email search by domain

<http://emailbydomain.com>

Auto manuals search

<http://auto.somanuals.com>

TV manuals search

<http://tv.somanuals.com>