

e-STUDIO™ 352/452

FASTstart

User Guide

Basic Fax Features

TOSHIBA
COPY • FAX • PRINT

Toshiba America Business Solutions, Inc. © 2006
Training and Dealer Development

Download from www.Somanuals.com. All Manuals Search And Download.

□ BASIC FAX FEATURES

□ Sending a FAX

- Preparation for Transmission
- Setting Originals
- Setting the Transmission Conditions
- Specifying the Remote Fax
- Sending Originals

□ Receiving a FAX

- Reception Modes
- Reception Settings

□ Sending a FAX

□ Preparation for Transmission

Switching to the FAX Mode

1. Press the **FAX** button on the control panel to select the Fax function.

- Be sure to switch over to the Fax mode before carrying out Fax operations.
- If you leave the digital copier for about 45 seconds, it automatically returns to the copy mode.
- You can also switch to the Fax mode when the digital copier is in the energy-saving mode.

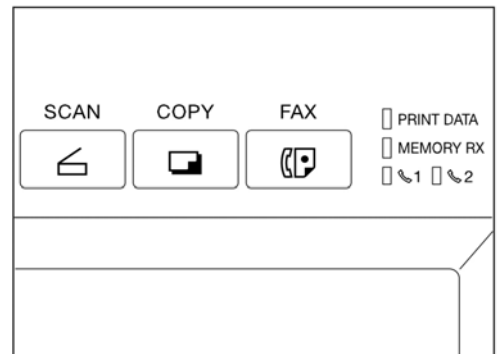

□ Sending a FAX (Cont'd.)

□ Setting Originals

When Setting Originals on the Glass

NOTE: Originals are sent in the order they are placed on the original glass in both the memory TX and direct TX modes.

1. Raise the Reversing Automatic Document Feeder, place the original (A) with its face down on the glass. Raise it 60 degrees or more to detect the original.

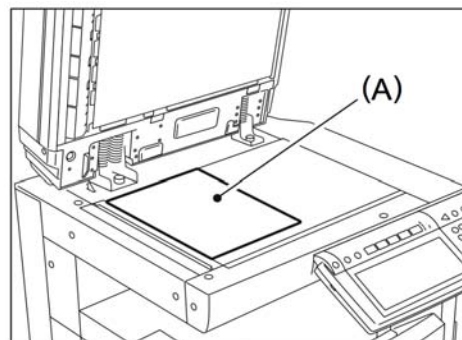

2. Align the original against the left inner corner of the glass.

- Different size originals can also be sent in one transmission.
- When LD, LG, LT-R, ST, COMP, A3, A4-R, A5, B4, B5 or FOLIO originals are placed as shown in the figure on the right, the pre-entered sender information is printed in the shaded position shown (B) in the figure and sent to the remote Fax.
- When LT, ST-R, A4, A5-R or B5-R originals are placed as shown in the figure on the right, the pre-entered sender information is printed in the shaded position shown (C) in the figure and sent to the remote Fax.

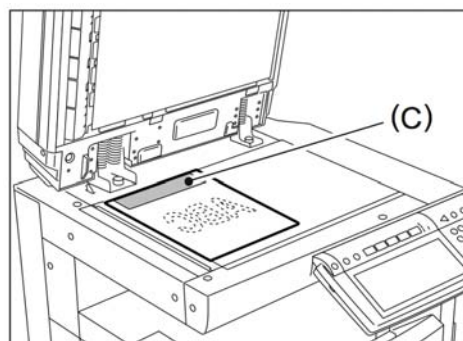
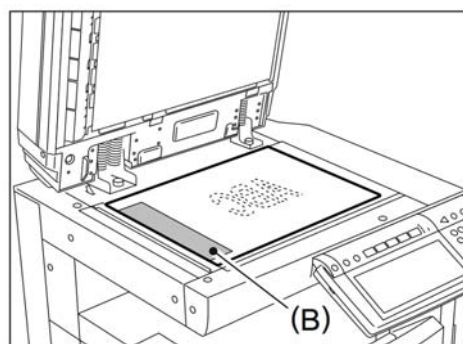

3. Lower the Reversing Automatic Document Feeder slowly.

□ Sending a FAX (Cont'd.)

□ Setting Originals

When Using the Reversing Automatic Document Feeder

NOTE: When the originals are placed on the Reversing Automatic Document Feeder, the uppermost page is first scanned and sent.

1. After aligning the edges of originals, place them with their face up and slide the guides to the width of the originals.

- You cannot mix A series format (A3, A4, A5) and B series format (B4, B5) or LT series and COMP. LT/A4 size originals are rotated 90° so that they are sent as LT-R/ A4-R originals.
- If a mixture of LD and LG, A3 and A4, or B4 and B5 originals are placed, they are sent in their original sizes.
- When LD, LG, LT-R, COMP, A3 and B4, A4-R, B5 originals are placed as shown in the figure on the right, the pre-entered sender information is printed in the shaded position shown (A) in the figure and sent to the remote Fax.
- When LT, ST-R, A4, A5-R or B5-R originals are placed as shown in the figure on the right, the pre-entered sender information is printed in the shaded position shown (B) in the figure and sent to the remote Fax.

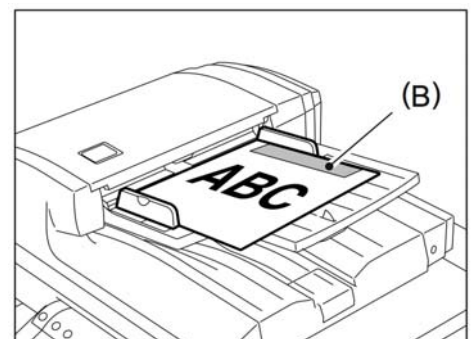
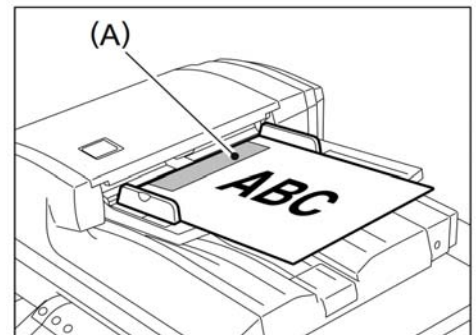
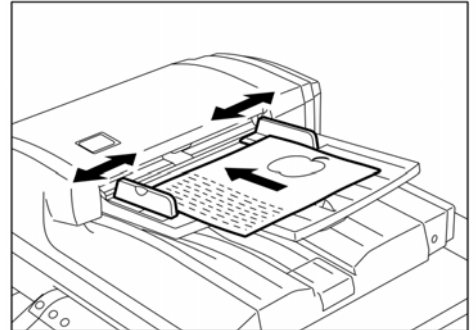

□ Sending a FAX (Cont'd.)

□ Setting the Transmission Conditions

Originals can be sent using different transmission conditions (resolution, image quality mode, exposure, transmission mode, original size, ECM, quality TX, Line, SUB/SEP/SID, PWD, subject and body). Settings for the subject and body are available only when using a function of the Internet Fax. If you change the transmission conditions, the new settings are valid for one transmission only. They are returned to the default settings after transmission.

1. Place the original(s).
2. Press the **FAX** button on the control panel.
3. Press the **ADDRESS** button to enter the address menu, and then press the **OPTION** button.
4. Press the desired buttons. Press the **Prev** or **Next** button to switch the screens. The highlighted buttons in the screens on the right are the default settings.
5. Press the **ENTER** button to complete the setting.
6. Specify the remote Fax and press the **START** button.

TIPS: When one remote Fax is specified by the address book, and the **OPTION** button is selected, the contents of the address setting will be reflected to the OPTION.

The settings of the TX type, ECM, quality TX, line select, SUB/ SEP and SID/PWD selected in the OPTION have priority.

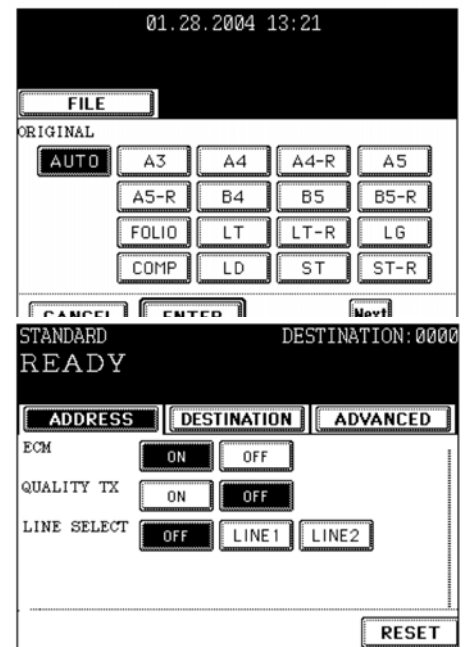
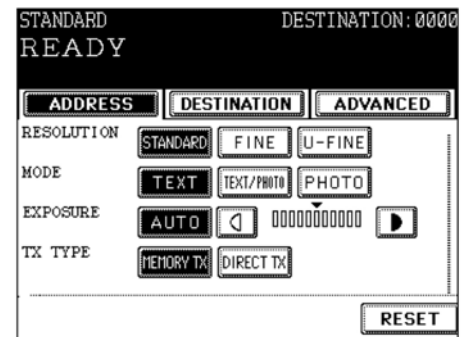
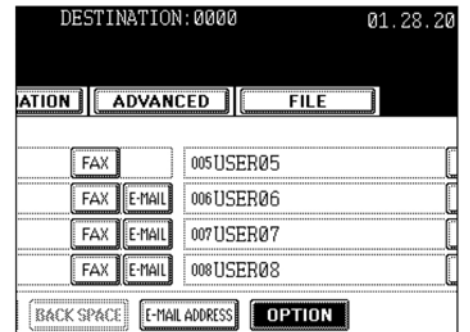

□ Sending a FAX (Cont'd.)

□ Specifying the Remote Fax

Direct Entry with Digital Keys

1. Place the original(s).
2. Press the **FAX** button on the control panel
3. Key in the remote Fax number.
4. If you make a mistake, press the **CLEAR** button on the control panel or the **BACK SPACE** button in the address menu and correct the mistake.
 - **CLEAR** button: Press this button to clear all values you have entered.
 - **BACK SPACE** button: Press this button to delete each value you have.

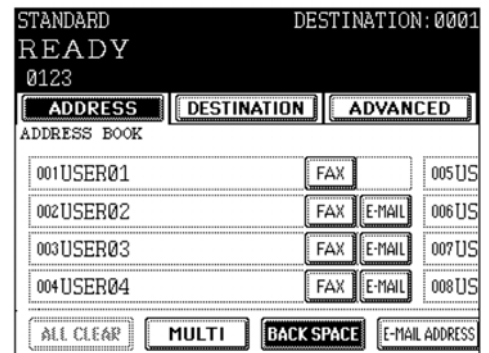
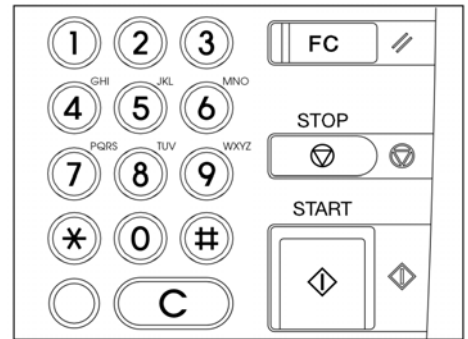

TIP: When you are dialing to an outside line via a PBX, there may be a pause before the connection is made, causing a transmission error. To avoid this error, press the **MONITOR/PAUSE** button after the number that designates an outside line to enter a pause. This automatically enters a 3-second pause before the remote Fax number is dialed, which reduces transmission errors. (The mark “-” is displayed as a “pause” on the screen.)

5. Press the **START** button.

Address Book Entry

Address book entry is the method for specifying remote Fax numbers by pressing the remote Fax buttons which have previously been registered. It is convenient if frequently used destinations are registered in the address book.

1. Place the original(s).
2. Press the **FAX** button on the control panel.
3. Press the **ADDRESS** button to enter the address menu. Each screen displays 8 destinations. To view destinations not displayed on the screen, press the **Prev** or **Next** button to switch the screens.
4. Press the button designating the remote Fax to which you wish to send your transmission.
5. Press the **START** button.

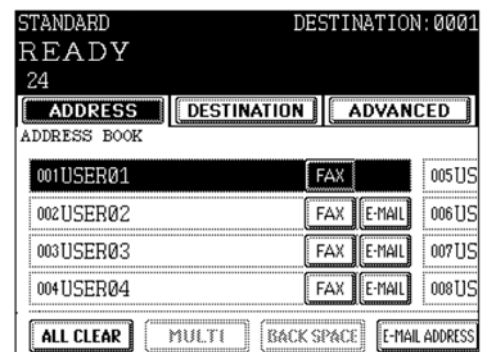
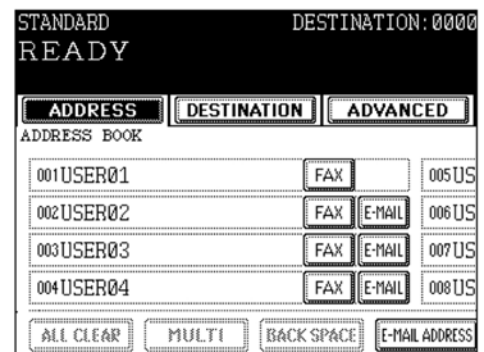

□ **Sending a FAX (Cont'd.)**

□ **Specifying the Remote Fax (Cont'd.)**

Group Entry

Group entry is the method of specifying remote Fax numbers by pressing the group button which has previously been entered. It is convenient if multiple frequently used multiple destinations are entered into a group.

1. Place the original(s).
2. Press the **FAX** button on the control panel.
3. Press the **ADDRESS** button to enter the address menu, then Press the **GROUP** button. Each screen displays 8 destinations. To view destinations not displayed on the screen, press the **Prev** or **Next** button to switch the screens.

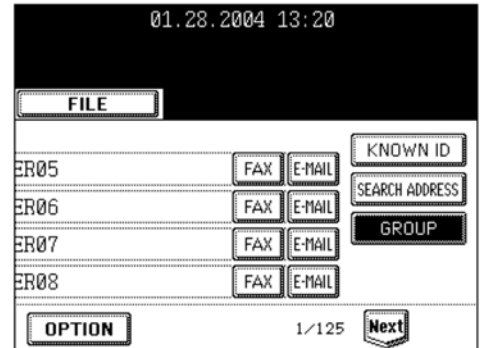

4. Press the remote Fax group to send originals. If you want to see the specified group members, press the **CONTENTS** button. You can search for groups by ID number and by group.

TIP: The Remote Faxes in the group can be confirmed in the group number information. See the **User Functions Guide**.

5. Press the **START** button.

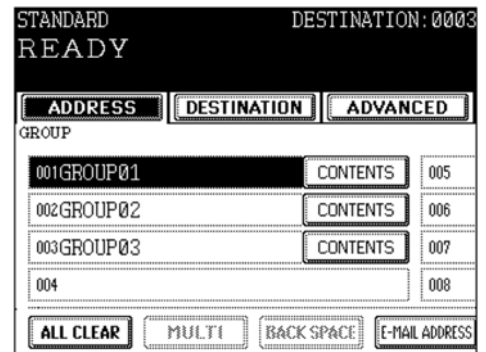

□ Specifying the Remote Fax (Cont'd.)

Multi-Address Transmission

The Multi-Address Transmission function allows you to send the same original to 2 or more remote Faxes in a single operation, which can be done by combining direct, address book and group entry. Combining with the Internet Fax is also available. This eliminates the trouble of placing the original and then dialing the number for each destination. Multi-address transmissions must be set in the memory TX mode.

The following shows the number of destinations that can be entered according to how the remote Fax is specified:

- By direct entry only: 400 destinations
- By address book entry only: 400 destinations
- By group entry only: 200 groups (400 destinations per a group)
- By combining direct, address book and group entry: 400 destinations

1. Place the original(s).
2. Press the **FAX** button on the control panel.
3. Press the **OPTION** button and set the transmission conditions.
4. Specify the remote Fax numbers.

- To continuously enter remote Fax numbers after having specified them by means of the digital keys, press the **MULTI** button, then enter the next number. You do not need to press the **MULTI** button for the address book or the group entry.
- The selected destinations can be confirmed by selecting the **DESTINATION** button.

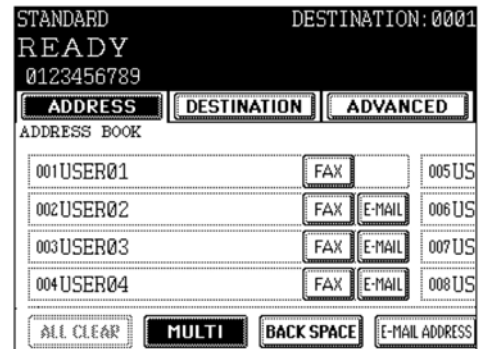

TIPS: To cancel the remote Fax number entered with digital keys, press the **CLEAR** button on the control panel.

To cancel a remote Fax specified with address book or group entry, press the highlighted button for the remote Fax again. To cancel all specified remote Faxes, press the **ALL CLEAR** button.

To cancel a remote Fax specified with direct entry, press the **DESTINATION** button to enter the destination menu, and then cancel it.

5. Specify all remote Faxes, then press the **START** button.

□ **Sending a FAX (Cont'd.)**

□ **Specifying the Remote Fax (Cont'd.)**

Searching by ID Number

When selecting the remote Faxes registered in the address and group by searching by the ID number immediately displays the screen including the searched-for ID number.

1. Place the original(s).
2. Press the **FAX** button on the control panel.
3. Press the **ADDRESS** button to enter the address menu, then the **KNOWN ID** button.

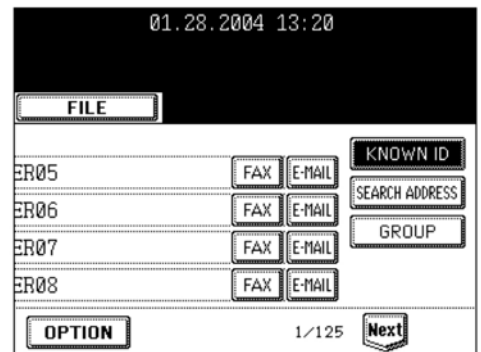

4. Key in the desired ID number, and press the **ENTER** button. You can key in the number within the range of 1 to 1000.

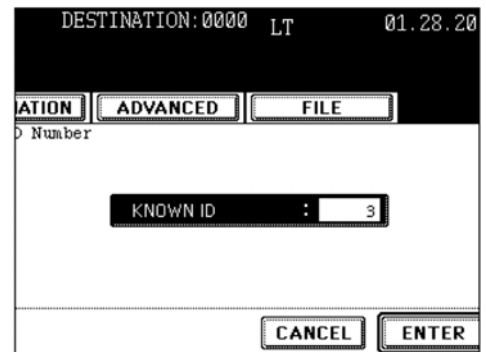

5. Press the button for the remote Fax that you want to send to.
 - Each screen displays 8 destinations.
 - To view destinations not displayed on the screen, press the **Prev** or **Next** button to switch the screens.

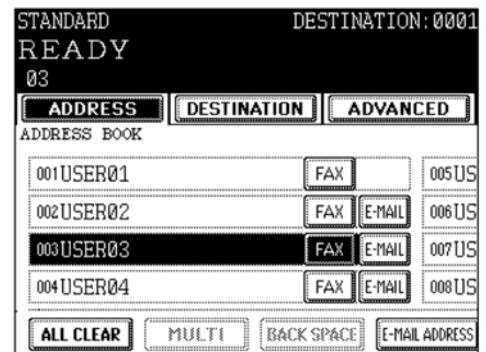

TIPS: To continue searching by ID number, press the **KNOWN ID** button.
 To continue searching by address, press the **SEARCH ADDRESS** button.

6. Press the **START** button.

□ **Sending a FAX (Cont'd.)**

□ **Specifying the Remote Fax (Cont'd.)**

Searching by Address (Search Address)

When selecting the remote Faxes registered in the address book and group, pressing a letter button displays the remote Faxes whose names start with the letter and/or numbers, which makes it easy to choose the desired remote Faxes.

1. Place the original(s).
2. Press the **FAX** button on the control panel.
3. Press the **ADDRESS** button to enter the address menu.
Press the **SEARCH ADDRESS** button.

4. Press the button you want to search.

5. Enter the ideal button or number, and then press the **ENTER** button.

6. Press the **SEARCH** button.

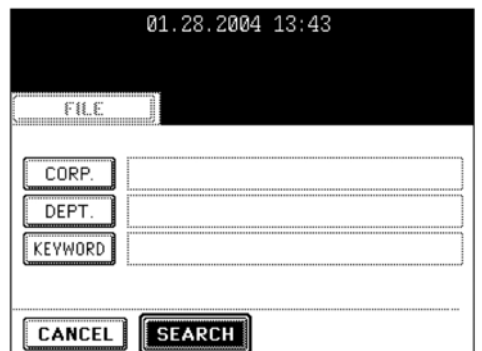
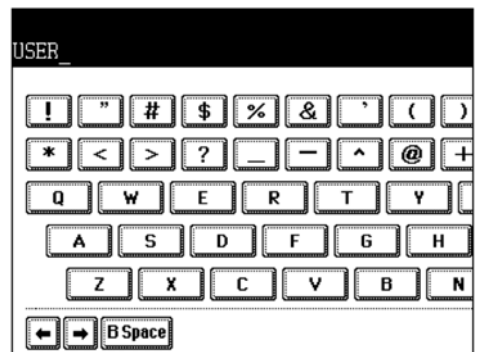
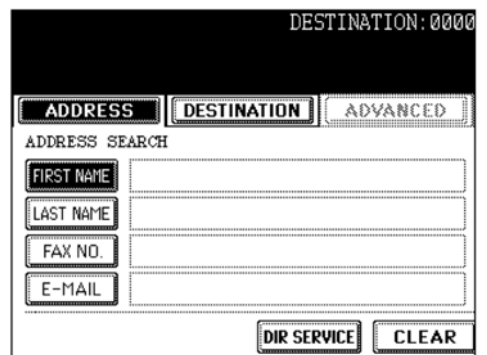
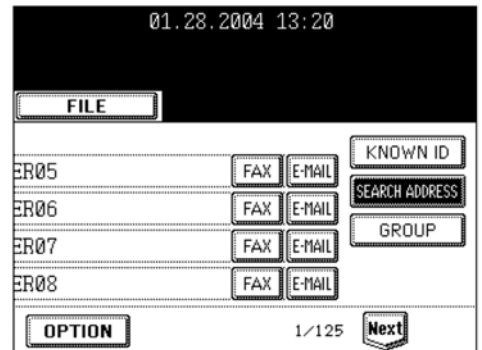

□ Sending a FAX (Cont'd.)

□ Specifying the Remote Fax (Cont'd.)

Searching by Address (Search Address) (Cont'd.)

7. Press the button for the remote Fax that you want to send to, and then press the **ENTER** button.

- Each screen displays 8 destinations. To view destinations not displayed on the screen, press the **Prev** or **Next** button to switch the screens.

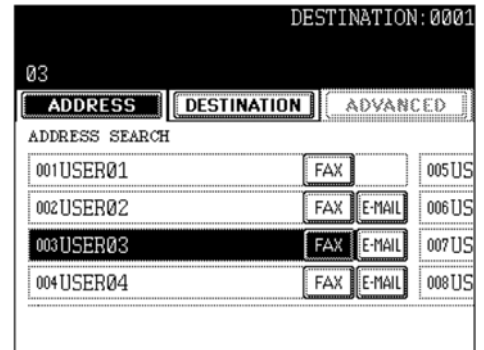

TIPS: To continue searching by the address, press the **SEARCH ADDRESS** button.

To continue searching by the ID number, press the **KNOWN ID** button.

8. Press the **START** button.

□ Sending a FAX (Cont'd.)

□ Sending Originals

Memory Transmission

In the Memory Transmission mode, originals are scanned at high speed and temporarily stored in memory before transmitting.

- Up to 100 transmissions can be reserved.
- Up to 1,000 pages can be stored in 1 transmission.
- If the original cannot be sent (the remote Fax is busy or otherwise unavailable), the remote Fax is automatically redialed repeatedly.
- Documents can no longer be added to memory if it becomes full midway during scanning. In this case, reduce the number of originals you are sending, or try sending in the Direct Transmission mode.
- If an original is placed on the original glass, the scanning conditions can be changed for each page.

1. Place the original(s).
2. Press the **FAX** button on the control panel.
3. Press the **ADDRESS** button to enter the address menu, then press the **OPTION** button.
4. Specify the remote Faxes.
5. Press the **START** button. The original will be scanned and stored in memory.

Direct Transmission

In the Direct Transmission mode, the remote Fax is immediately dialed, and the originals are sent after a successful connection with the remote Fax that has been completed.

- Users can check immediately if the original has been sent to the remote Fax.
- Once scanned, the originals are not stored in the memory.
- Users can specify only one remote Fax at a time.
- After a page has been sent, the next page is scanned. It takes longer to scan all pages.
- If an original is placed on the original glass, the scanning conditions can be changed for each page.

1. Place the original.
2. Press the **FAX** button on the control panel.
3. Press the **OPTION** button.
4. Press the **DIRECT TX** button, set the other transmission conditions, then press the **SET** button.
5. Specify the remote Faxes.
6. Press the **START** button. The remote Fax is dialed immediately and communication is initiated.

□ Receiving a FAX

□ Reception Modes

Automatic Reception

- Faxes are automatically received during the incoming call.
- The line is designated for use exclusively by the Fax.

Manual Reception

- Faxes are received when the user confirms the call on the telephone; press the **MANUAL RECEIVE** button in the advanced menu and then the **START** button.
- An external telephone is required (not available for the European version).

Memory Reception

- This model of the copier automatically stores received originals in memory if an error (e.g. a paper jam or out of paper) occurs during reception and prevents the originals from being printed. After the trouble has been cleared, printing is automatically resumed. Memory Reception works in the following conditions:
 - During copying
 - During printing of received originals
 - During printing of lists and reports
 - When the digital copier has run out of paper
 - When a paper jam occurs
 - When the digital copier has run out of toner

Mailbox Reception

- You can retrieve documents from mailbox hubs (confidential, bulletin board) that support the ITU-T Mailbox functions.

Polling Reception

- Users request transmission from a remote Fax, and receive the original that is stored in the remote Fax's memory.
- There are 2 types of polling RX: individual polling RX and multi-polling RX
- A password can be set.

□ Receiving a FAX

□ Reception Settings

There are two reception modes: Auto Reception and Manual Reception.

AUTO Reception: Set this mode when the phone line is used exclusively for Faxing. The FAX automatically receives incoming originals.

MANUAL Reception: Set this mode when the Fax is connected to a line also used exclusively for telephone calls.

1. Press the **USER FUNCTIONS** button on the control panel.
2. Press the **ADMIN** button, key in the administrator password (6 digits) and press the **ENTER** button.

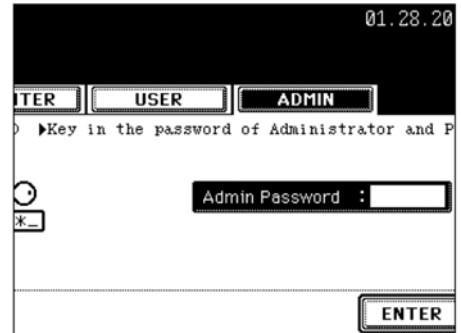

3. Press the **FAX** button.

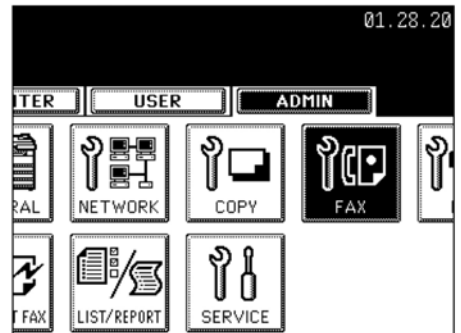

4. Press the **INITIAL SETUP** button.

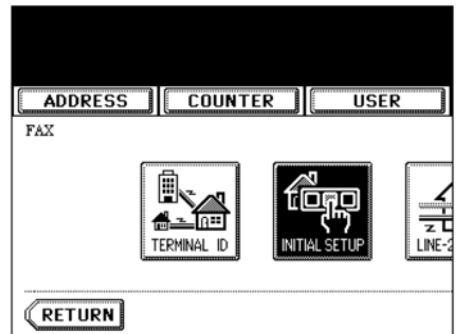

5. Press the **AUTO** or **MANUAL** button to select the reception mode, and then press the **ENTER** button.

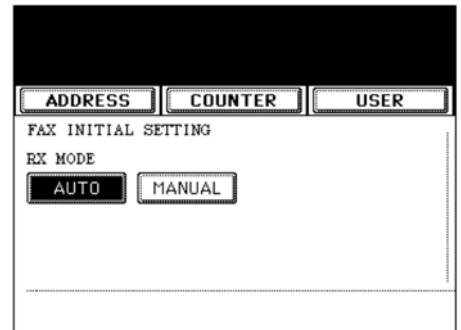

□ **Receiving a FAX (Cont'd.)**

□ **Reception Settings (Cont'd.)**

Manual Reception

1. When the bell rings, pick up the handset of an external telephone. If the incoming call is a telephone call, start talking with the other party.
2. If you hear a tone (Fax signal), press the **FAX** button on the control panel.

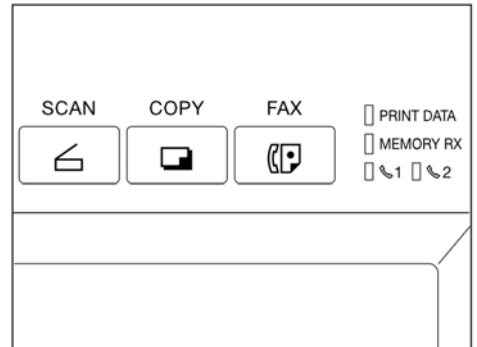

3. Press the **ADVANCED** button to enter the advanced menu, and then press the **MANUAL RECEIVE** button.

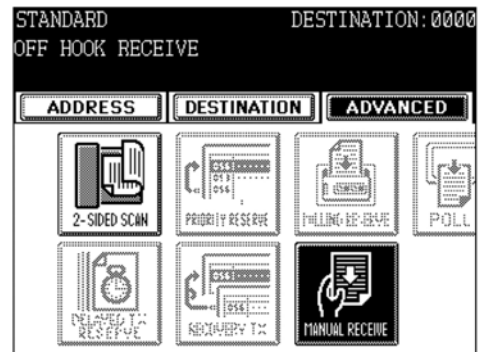

4. Make sure that “OFF HOOK RECEIVE” appears, press the **START** button and replace the handset.

Free Manuals Download Website

<http://myh66.com>

<http://usermanuals.us>

<http://www.somanuals.com>

<http://www.4manuals.cc>

<http://www.manual-lib.com>

<http://www.404manual.com>

<http://www.luxmanual.com>

<http://aubethermostatmanual.com>

Golf course search by state

<http://golfingnear.com>

Email search by domain

<http://emailbydomain.com>

Auto manuals search

<http://auto.somanuals.com>

TV manuals search

<http://tv.somanuals.com>