

**TEC**

TEC Label Printer

**B-419-GS10-QQ**

**Owner's Manual**

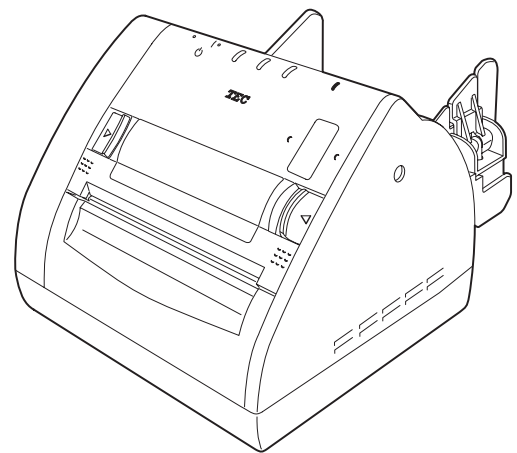

**TOSHIBA TEC CORPORATION**

This equipment has been tested and found to comply with the limits for a Class A digital device, pursuant to Part 15 of the FCC Rules, These limits are designed to provide reasonable protection against harmful interference when the equipment is operated in a commercial environment. This equipment generates, uses, and can radiate radio frequency energy and, if not installed and used in accordance with the instruction manual, may cause harmful interference to radio communications. Operations of this equipment in a residential area is likely to cause harmful interference in which case the user will be required to correct the interference at his own expense.

(for USA only)

Changes or modifications not expressly approved by manufacturer for compliance could void the user's authority to operate the equipment.

"This Class A digital apparatus meets all requirements of the Canadian Interference-Causing Equipment Regulations."

"Cet appareil numérique de la classe A respecte toutes les exigences du Règlement sur le matériel brouilleur du Canada."

(for CANADA only)

## Safety Summary

Personal safety in handling or maintaining the equipment is extremely important. Warnings and Cautions necessary for safe handling are included in this manual. All warnings and cautions contained in this manual should be read and understood before handling or maintaining the equipment.

Do not attempt to effect repairs or modifications to this equipment. If a fault occurs that cannot be rectified using the procedures described in this manual, turn off the power, unplug the machine, then contact your authorized TOSHIBA TEC representative for assistance.

### Meanings of Each Symbol



This symbol indicates warning items (including cautions). Specific warning contents are drawn inside the  $\Delta$  symbol. (The symbol on the left indicates a general caution.)



This symbol indicates prohibited actions (prohibited items). Specific prohibited contents are drawn inside or near the  $\odot$  symbol. (The symbol on the left indicates “no disassembling”.)



This symbol indicates actions which must be performed. Specific instructions are drawn inside or near the  $\bullet$  symbol. (The symbol on the left indicates “disconnect the power cord plug from the outlet”.)



### WARNING

This indicates that there is the risk of **death** or **serious injury** if the machines are improperly handled contrary to this indication.



**Any other than the specified AC voltage is prohibited.**

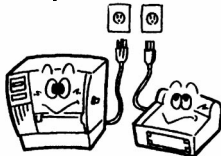

Do not use voltages other than the voltage (AC) specified on the rating plate, as this may cause **fire** or **electric shock**.



**Prohibited**

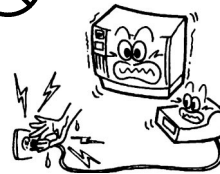

Do not plug in or unplug the power cord plug with wet hands as this may cause **electric shock**.



**Prohibited**



If the machines share the same outlet with any other electrical appliances which consume large amounts of power, the voltage will fluctuate widely each time these appliances operate. Be sure to provide an exclusive outlet for the machine as this may cause **fire** or **electric shock**.



**Prohibited**



Do not place metal objects or water-filled containers such as flower vases, flower pots or mugs, etc. on top of the machines. If metal objects or spilled liquid enter the machines, this may cause **fire** or **electric shock**.



**Prohibited**

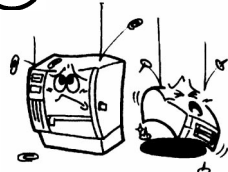

Do not insert or drop metal, flammable or other foreign objects into the machines through the ventilation slits, as this may cause **fire** or **electric shock**.



**Prohibited**



Do not scratch, damage or modify the power cords. Also, do not place heavy objects on, pull on, or excessively bend the cords, as this may cause **fire** or **electrical shock**.



**Disconnect the plug.**









If the machines are dropped or their cabinets damaged, first turn off the power switches and disconnect the power cord plugs from the outlet, and then contact your authorized TOSHIBA TEC representative for assistance. Continued use of the machine in that condition may cause **fire** or **electric shock**.



**Disconnect the plug.**

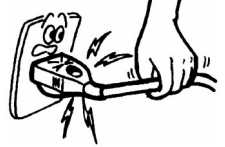

Continued use of the machines in an abnormal condition such as when the machines are producing smoke or strange smells may cause **fire** or **electric shock**. In these cases, immediately turn off the power switches and disconnect the power cord plugs from the outlet. Then, contact your authorized TOSHIBA TEC representative for assistance.

 <p><b>Disconnect the plug.</b></p> 	<p>If foreign objects (metal fragments, water, liquids) enter the machines, first turn off the power switches and disconnect the power cord plugs from the outlet, and then contact your authorized TOSHIBA TEC representative for assistance. Continued use of the machine in that condition may cause <b>fire</b> or <b>electric shock</b>.</p>	 <p><b>Disconnect the plug.</b></p> 	<p>When unplugging the power cords, be sure to hold and pull on the plug portion. Pulling on the cord portion may cut or expose the internal wires and cause <b>fire</b> or <b>electric shock</b>.</p>
 <p><b>Connect a grounding wire.</b></p> 	<p>Ensure that the equipment is properly grounded. Extension cables should also be grounded. <b>Fire</b> or <b>electric shock</b> could occur on improperly grounded equipment.</p>	 <p><b>No disassembling.</b></p> 	<p>Do not remove covers, repair or modify the machine by yourself. You may be <b>injured</b> by high voltage, very hot parts or sharp edges inside the machine.</p>



**CAUTION**

This indicates that there is the risk of personal **injury** or **damage** to objects if the machines are improperly handled contrary to this indication.

**Precautions**

The following precautions will help to ensure that this machine will continue to function correctly.

- Try to avoid locations that have the following adverse conditions:
  - \* Temperatures out of the specification
  - \* Shared power source
- \* Direct sunlight
- \* Excessive vibration
- \* High humidity
- \* Dust/Gas
- The cover should be cleaned by wiping with a dry cloth or a cloth slightly dampened with a mild detergent solution. NEVER USE THINNER OR ANY OTHER VOLATILE SOLVENT on the plastic covers.
- USE ONLY TOSHIBA TEC SPECIFIED paper and ribbons.
- DO NOT STORE the paper or ribbons where they might be exposed to direct sunlight, high temperatures, high humidity, dust, or gas.
- Ensure the printer is operated on a level surface.
- Any data stored in the memory of the printer could be lost during a printer fault.
- Try to avoid using this equipment on the same power supply as high voltage equipment or equipment likely to cause mains interference.
- Unplug the machine whenever you are working inside it or cleaning it.
- Keep your work environment static free.
- Do not place heavy objects on top of the machines, as these items may become unbalanced and fall causing **injury**.
- Do not block the ventilation slits of the machines, as this will cause heat to build up inside the machines and may cause **fire**.
- Do not lean against the machine. It may fall on you and could cause **injury**.
- Care must be taken not to injure yourself with the printer paper cutter.
- Unplug the machine when it is not used for a long period of time.

**Request Regarding Maintenance**

- Utilize our maintenance services.  
After purchasing the machine, contact your authorized TOSHIBA TEC representative for assistance once a year to have the inside of the machine cleaned. Otherwise, dust will build up inside the machines and may cause a **fire** or a **malfunction**. Cleaning is particularly effective before humid rainy seasons.
- Our preventive maintenance service performs the periodic checks and other work required to maintain the quality and performance of the machines, preventing accidents beforehand.  
For details, please consult your authorized TOSHIBA TEC representative for assistance.
- Using insecticides and other chemicals  
Do not expose the machines to insecticides or other volatile solvents. This will cause the cabinet or other parts to deteriorate or cause the paint to peel.

## TABLE OF CONTENTS

	Page
<b>1. PRODUCT OVERVIEW .....</b>	<b>1-1</b>
1.1 Introduction .....	1-1
1.2 Features .....	1-1
1.3 Unpacking .....	1-1
1.4 Accessories .....	1-2
1.5 Appearance .....	1-2
1.5.1 Dimensions .....	1-2
1.5.2 Front View .....	1-3
1.5.3 Rear View .....	1-3
1.5.4 Interior .....	1-3
1.5.5 Operation Panel .....	1-4
<b>2. PRINTER SETUP .....</b>	<b>2-1</b>
2.1 Precautions .....	2-1
2.2 Procedure before Operation .....	2-2
2.3 Connecting the Cables to Your Printer .....	2-2
2.4 Connecting the Power Cord .....	2-3
2.5 Turning the Printer ON/OFF .....	2-4
2.5.1 Turning ON the Printer .....	2-4
2.5.2 Turning OFF the Printer .....	2-4
2.6 Opening/Closing the Media Cover .....	2-5
2.7 Loading the Media .....	2-6
2.7.1 Loading the Fanfold Paper .....	2-7
2.7.2 Loading the Cut Form .....	2-8
2.8 Removing/Installing the Paper Guide Unit .....	2-9
2.9 Test Print .....	2-10
2.10 Program Download .....	2-13
2.10.1 Outline of Features .....	2-13
2.10.2 Install Program Installation .....	2-13
2.10.3 Firmware Files Copy .....	2-17
2.10.4 Sensor Adjustments .....	2-23
2.10.5 Printer Information Registration .....	2-26
2.10.6 Test Print .....	2-28
2.10.7 Version Display .....	2-29
<b>3. MAINTENANCE .....</b>	<b>3-1</b>
3.1 Cleaning .....	3-1
3.1.1 Print Head/Platen .....	3-1
3.1.2 Paper Path/Sensors .....	3-2
3.1.3 Covers .....	3-2
3.2 Care/Handling of the Media .....	3-2

<b>4. TROUBLESHOOTING.....</b>	<b>4-1</b>
4.1 LED State .....	4-1
4.2 Error Process.....	4-2
4.3 Possible Problems .....	4-3
4.4 Removing Jammed Media .....	4-3
<b>APPENDIX 1 SPECIFICATIONS.....</b>	<b>A1-1</b>
A1.1 Printer .....	A1-1
A1.2 Media.....	A1-2
A1.2.1 Media Type.....	A1-2
<b>APPENDIX 2 INTERFACE .....</b>	<b>A2-1</b>
<b>APPENDIX 3 PRINT SAMPLES.....</b>	<b>A3-1</b>
<b>GLOSSARIES</b>	
<b>INDEX</b>	

**WARNING!**

*This is a Class A product. In a domestic environment this product may cause radio interference in which case the user may be required to take adequate measures.*

**CAUTION!**

1. *This manual may not be copied in whole or in part without prior written permission of TOSHIBA TEC.*
2. *The contents of this manual may be changed without notification.*
3. *Please refer to your local authorized service representative with regard to any queries you may have in this manual.*

# 1. PRODUCT OVERVIEW

## 1.1 Introduction

Thank you for choosing the TEC B-419 series label printer. This Owner's Manual contains information about general set-up through how to confirm the printer's operation using a test print. This manual should be read carefully to help gain maximum performance and life from your printer. For most queries please refer to this manual and keep it safe for future reference. Please contact your TOSHIBA TEC representative for further information concerning this manual.

## 1.2 Features

The B-419 printer has the following features:

- The paper auto feed function is provided for the first time for a 4 inch wide, small and light desk top printer.
- To meet various applications, four types of issue modes, such as, the TEC Printer Command Language Light Edition (TPCL-LE) mode, high speed graphic mode, label issue mode, and receipt issue mode, are supported as standard.  
For details, please inquire from your nearest TOSHIBA TEC representative.
- This printer can print cut forms as standard, which allows ticket issuing.

## 1.3 Unpacking

Unpack the printer as per the Unpacking Instructions supplied with the printer.

**NOTES:**

1. *Check for damage or scratches on the printer. However, please note that TOSHIBA TEC shall have no liability for any damage of any kind sustained during transportation of the product.*
2. *Keep the cartons and packaging for future transportation of the printer.*

## 1.4 Accessories

When unpacking the printer, please make sure all the following accessories have been supplied with the printer.

Owner's Manual (1 copy)  
(Doc./No. EO1-33030)

Power Cord (1 pc.)  
(P/No.FBCB0030202)

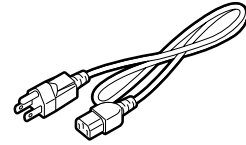
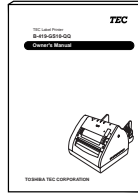

## 1.5 Appearance

The names of the parts or units introduced in this section are used in the following chapters.

### 1.5.1 Dimensions

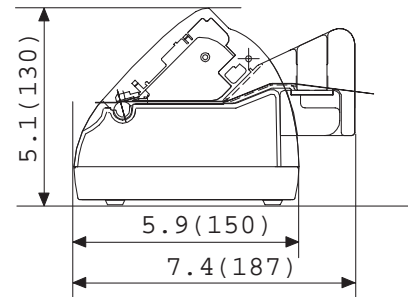
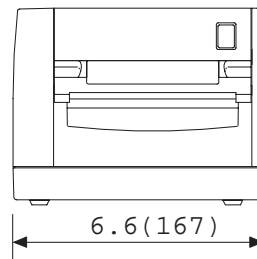

Dimensions in inch+(mm)



1.5.2 Front View

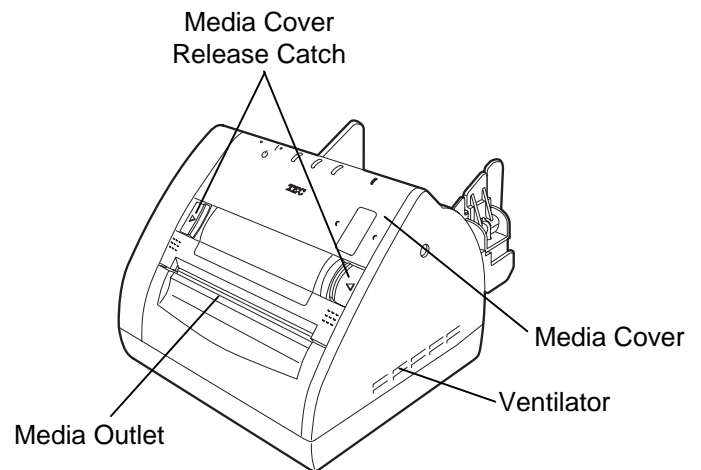

1.5.3 Rear View

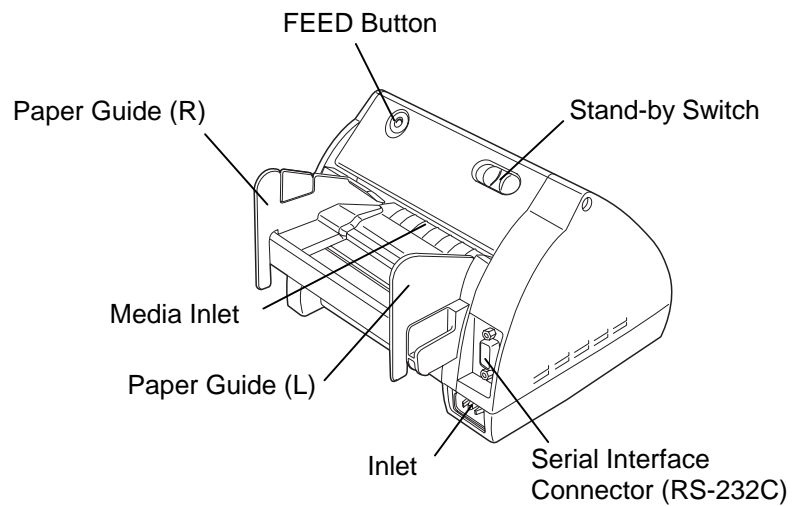

1.5.4 Interior

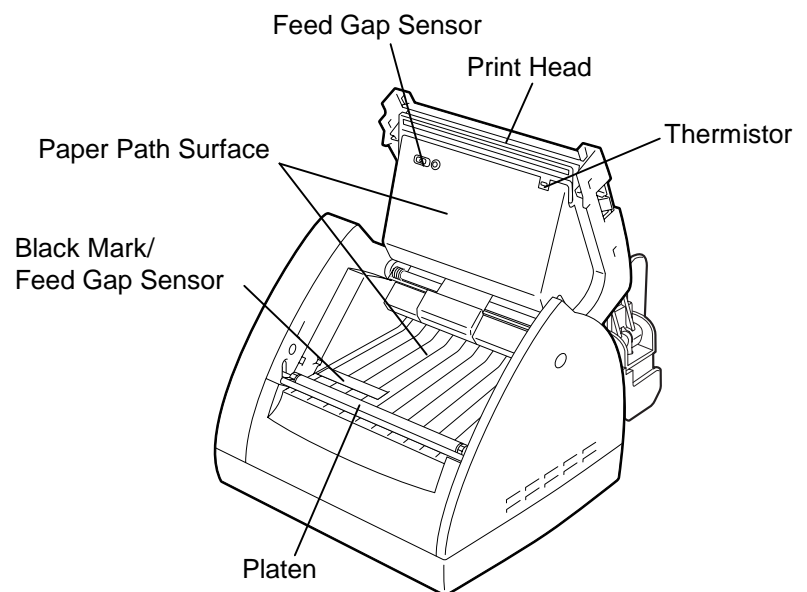

1.5.5 Operation Panel

The figure below illustrates the Operation Panel and key functions.

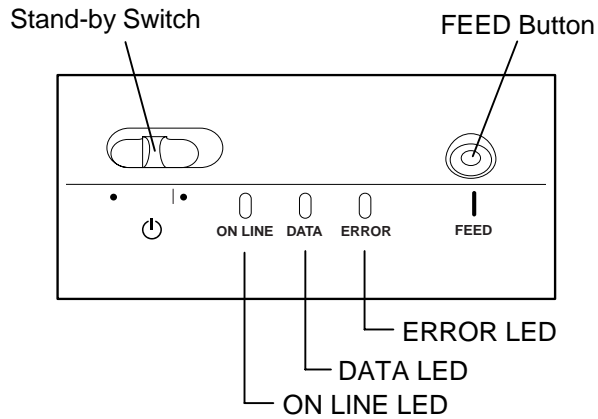

There are three LED lights on the Operation Panel.

LED	Illuminates when...	Flashes when...
ON LINE	The printer is turned on.	-----
DATA	The printer is in operation. (Goes off when in Idle.)	Flashes fast when the printer is communicating with the PC. Flashes slowly when the print data remains.
ERROR	The print head has a broken element.	Paper feed jam, cover open, communication error, etc. occurs. For details, refer to Section 4.1 LED State.

There are two switches on the Operation Panel.

STAND-BY Switch	A slide power switch. The power is turned ON when the switch is positioned to the (I) side. The power is turned OFF when the switch is positioned to the other side.
FEED Button	Each time this button is pressed, the printer feeds one piece of media.

**CAUTION!**

Even if the Stand-by switch is turned off, the primary power remains ON, as this switch turns on/off the secondary power supply only. When the printer is not used for a long time, disconnect the power cord from the AC outlet.

## 2. PRINTER SETUP

This section outlines the procedures to setup your B-419 printer prior to its operation. The section includes precautions, connecting cables, assembling accessories, loading media, and performing a test print.

### 2.1 Precautions

To ensure the best operating environment, and to assure the safety of the operator and the equipment, please observe the following precautions.

- Operate the printer on a stable, level, operating surface in a location free from excessive humidity, high temperature, dust, vibration or direct sunlight.
- Keep your work environment static free. Static discharge can cause damage to delicate internal components.
- Make sure that the printer is connected to a clean source of AC Power and that no other high voltage devices that may cause line noise interference are connected to the same mains.
- Ensure that the printer is connected to the AC mains with a three-prong power cable that has the proper ground (earth) connection.
- Turn off the printer power and remove the power cord from the printer whenever working on the inside of the printer such as loading the media, or when cleaning the printer.
- For best results, and longer printer life, use only TOSHIBA TEC recommended media.
- Store the media in accordance with the specifications.
- This printer mechanism contains high voltage components; therefore you should never remove any of the covers of the machine as you may receive an electrical shock. Additionally, the printer contains many delicate components that may be damaged if accessed by unauthorized personnel.
- Clean the outside of the printer with a clean dry cloth or a clean cloth slightly dampened with a mild detergent solution.
- Use caution when cleaning the thermal print head as it may become very hot while printing. Wait until it has had time to cool before cleaning.
- Do not turn off the printer power or remove the power plug while the printer is printing or while the ON LINE lamp is blinking.
- Ensure that there is an AC outlet that can be used only for the printer close to the printer installation location.

## 2.2 Procedure before Operation

### NOTES:

1. To communicate with the host computer, a 9-pin RS-232C cable is required.
2. The printer can also be controlled with its own programming commands. Please contact your TOSHIBA TEC reseller for the Interface/Communication Manual.

This section describes the outline of the printer setup.

1. Unpack the accessories and printer from the box.
2. Refer to Safety Precautions in this manual and set up the printer in a suitable location.
3. The host computer must have a serial port. (Refer to Section 2.3.)
4. Be sure to insert the power cord plug into an AC outlet. (Refer to Section 2.4.)
5. Load the media in the printer. (Refer to Section 2.7.)
6. Turn the Power ON. (Refer to Section 2.5.)
7. Perform a test print. (Refer to Section 2.9.)
8. Install the Printer Drivers.

## 2.3 Connecting the Cables to Your Printer

### CAUTION!

The RS-232C must be connected while the power is turned OFF. Failure to do this may cause electric shock or short-circuit.

When connecting the RS-232C cable to your printer, follow the procedure described below.

1. Make sure that the power cord is not connected to the AC outlet.
2. Connect the printer side connector of the RS-232C cable to the serial port on the rear of the printer.

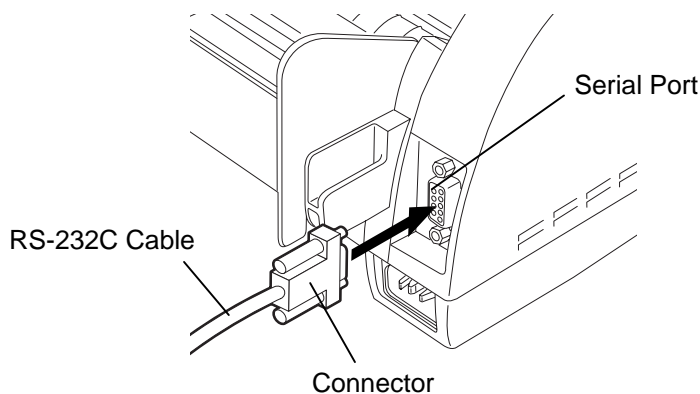

3. Secure the connector with the screws.

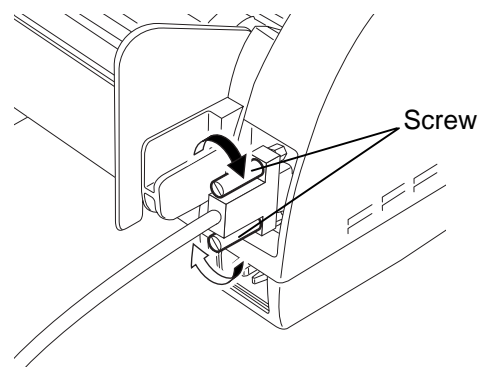

4. Connect the PC side connector of the RS-232C cable to the Serial port of your PC.

## 2.4 Connecting the Power Cord

### CAUTION!

1. Make sure that the printer Stand-by switch is turned to the off position before connecting the power cord to prevent possible electric shock or damage to the printer.
2. Use only the power cord supplied with the printer. Use of any other cord may cause electric shock or fire.
3. Connect the power cord to a three-prong outlet only, with the third prong being a good ground (earth) connection.
4. Even if the Stand-by switch is turned off, the primary power remains ON, as this switch turns on/off the secondary power supply only. When the printer is not used for a long time, disconnect the power cord from the AC outlet.

1. Make sure that the Stand-by switch is in the OFF position.

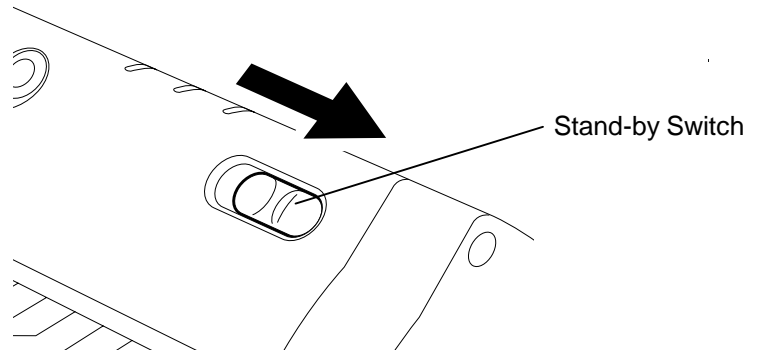

2. Connect the Power Cord to the printer as shown in the figure below.

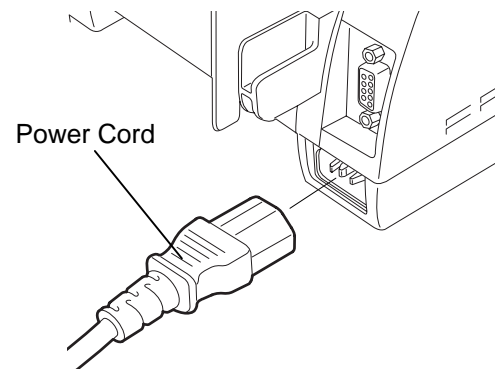

3. Plug the other end of the Power Cord into the ground outlet as shown in the figure below.

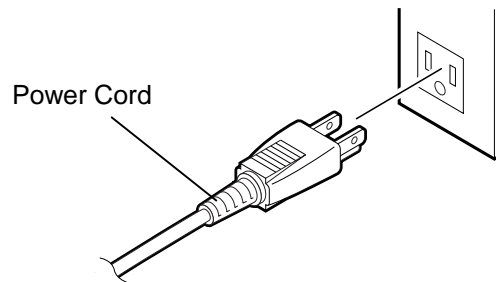

## 2.5 Turning the Printer ON/OFF

When the printer is connected to your host computer it is good practice to turn the printer ON before turning on your host computer and turn OFF your host computer before turning off the printer.

### 2.5.1 Turning ON the Printer

#### CAUTION!

Use the Stand-by switch to turn the printer On/Off. Plugging or unplugging the power cord to turn the printer On/Off may cause fire, an electric shock, or damage to the printer.

#### NOTE:

When the **ERROR LED** is illuminated, refer to Section 4.1 LED State.

1. To turn ON the printer power, slide the Stand-by switch as shown in the diagram below. Note that ( I ) is the power ON side of the switch.

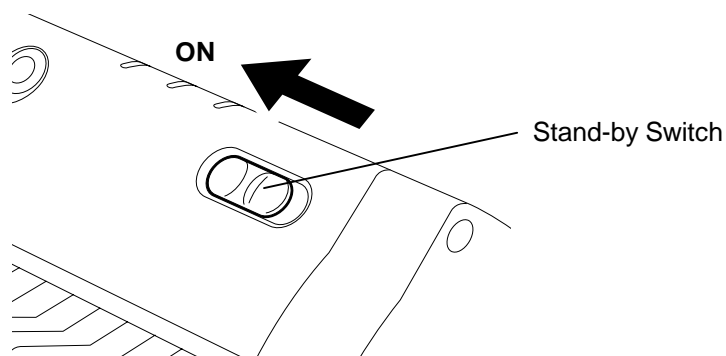

2. Check that the **ON LINE LED** is illuminated.

### 2.5.2 Turning OFF the Printer

#### CAUTION!

1. Do not turn off the printer power while the media is being printed as this may cause a paper jam or damage to the printer.
2. Do not turn off the printer power while the **ON LINE** light is blinking as this may cause damage to your computer.

1. To turn OFF the printer power, slide the Stand-by switch as shown in the diagram below. Note that no mark is printed on the power OFF side.

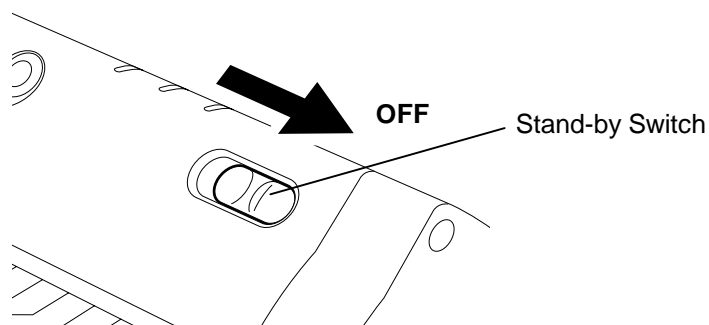

## 2.6 Opening/Closing the Media Cover

### **WARNING!**

*The Media Cover should be opened fully. Failure to do this may cause the Media Cover to close by its weight, resulting in injury.*

This section describes the opening and closing procedure of the Media Cover. Follow the procedure when cleaning the print head, platen, paper passage, or media sensor, or removing jammed paper.

### Opening the Media Cover

1. Release the Media Cover by pushing both sides of the Media Cover Release Catches toward the center, and then open the Media Cover.

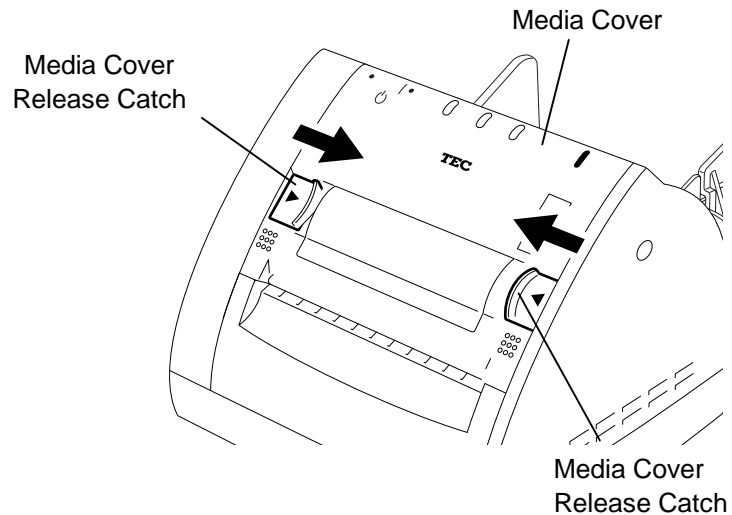

### Closing the Media Cover

1. Close the Media Cover by pressing portions (A) until they click.
2. Make sure that both Media Cover Release Catches are in position and the Media Cover is locked.

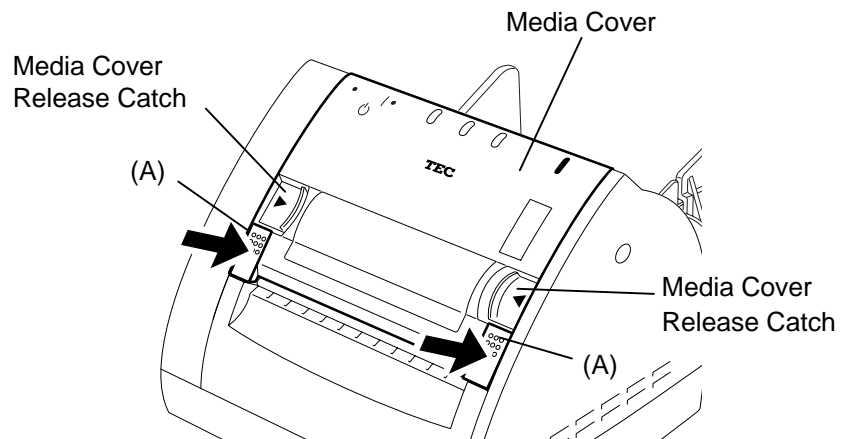

## 2.7 Loading the Media

The B-419 printer issues in two issue modes depending on the media types.

### Continuous mode (Fanfold paper)

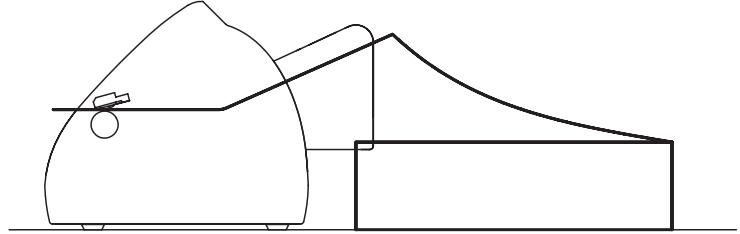

- Insert the media through the media inlet, or open the media cover and set the media, and then close the media cover.
- When the print command is received from the PC, the specified numbers of media are printed continuously.
- Pressing the **[FEED]** button causes one piece of media to be fed.

### Cut form mode (When the auto-feed is turned ON.)

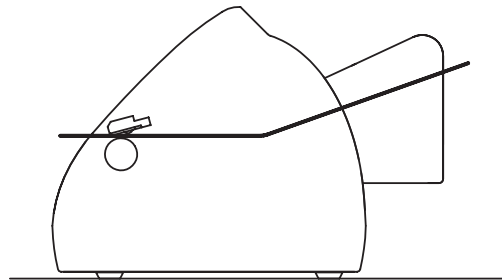

- Insert the media through the media inlet, or open the media cover and set the form, and then close the media cover. The media is automatically fed to the print start position.
- When the print command is received from the PC, the specified numbers of media are printed one by one.
- When unprinted data remains after issuing the media, the DATA LED flashes slowly (indicating the printer is waiting for media supply.)
- Pressing the **[FEED]** button causes one piece of media to be fed.



### 2.7.1 Loading the Fanfold Paper

#### NOTES:

1. Place the fanfold paper so that the print surface faces up and the top edge of the paper is positioned at the printer side.

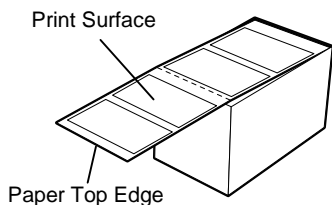

2. Place the fanfold paper on the surface below the position of the printer's media inlet.

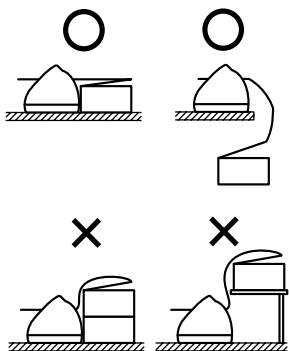

#### NOTE:

Do not pull the printed paper. Doing so may dislocate the printer or misalign the print position, causing a print failure.

1. Place the fanfold paper at the rear of the printer in line.

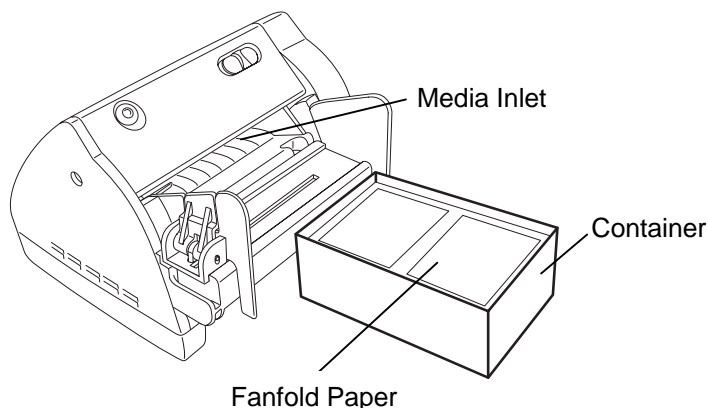

2. Place the paper top edge in front of the Media Inlet, and align the left paper edge with the Paper Guide (L). Push the Paper Guide Release Lever outside, and align the Paper Guide (R) with the right paper edge.
3. Lock the Paper Guide by pulling the Paper Guide Release Lever up.

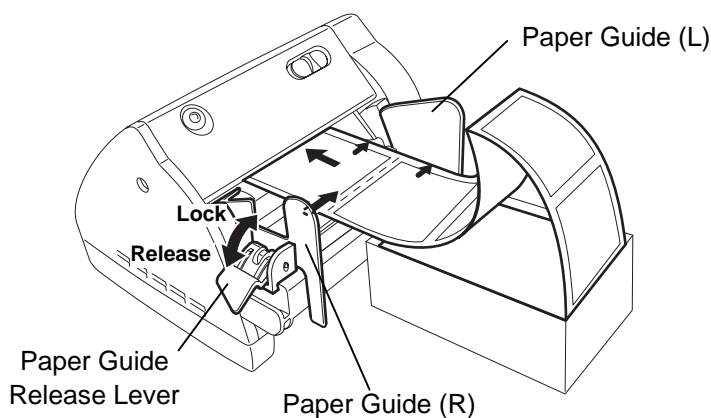

4. Turn the PC power ON, and then turn the printer power ON.
5. Insert the paper top edge into the Media Inlet until it stops. Pressing the **[FEED]** button feeds one piece of the paper.
6. Send a print data from the PC.
7. The data is printed on the paper. Tear off the printed paper at the edge of the Media Outlet.

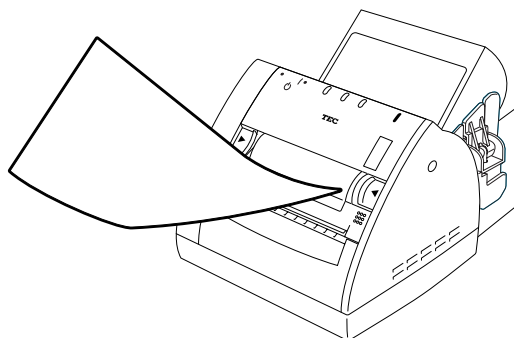

### 2.7.2 Loading the Cut Form

**NOTE:**

The *AUTO FEED* function is available when selected by the printer setting and black marks are printed on the media as shown below. For details of the printer setting, please contact your nearest TOSHIBA TEC representative.

To activate the *AUTO FEED* function, insert the black mark side of the media into the Media Inlet until it stops. The media will be automatically fed to the print start position.

**Reverse side of the media**

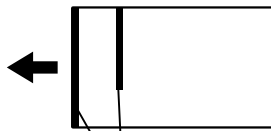

Black Mark

1. Place the paper top edge in front of the Media Inlet, and align the left paper edge with the Paper Guide (L). Push the Paper Guide Release Lever outside, and align the Paper Guide (R) with the right paper edge.
2. Lock the Paper Guide by pulling the Paper Guide Release Lever up.

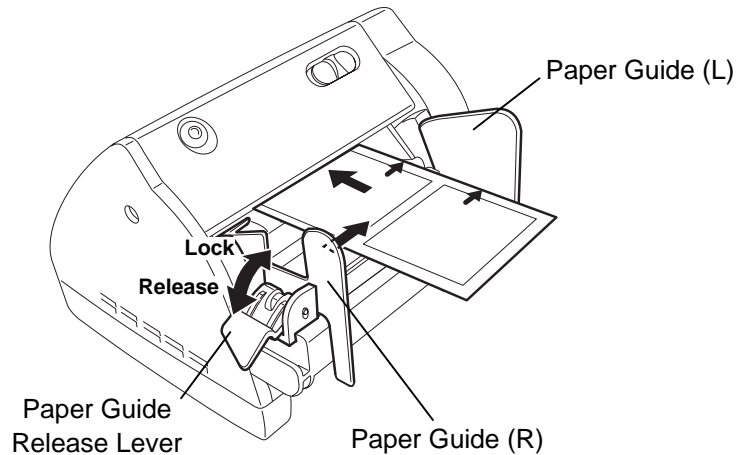

3. Turn the PC power ON, and then turn the printer power ON.
4. Insert the paper top edge into the Media Inlet until it stops.
5. Send a print data from the PC. The data is printed on the paper

## 2.8 Removing/Installing the Paper Guide Unit

When using 4.3" (109 mm) wide media, remove the Paper Guide Assembly as follows.

1. Make sure that the Power Cord is not connected to the AC outlet.
2. Press the Paper Guide Release Lever outside and move the Paper Guide (R) toward the center.

Paper Guide Release Lever

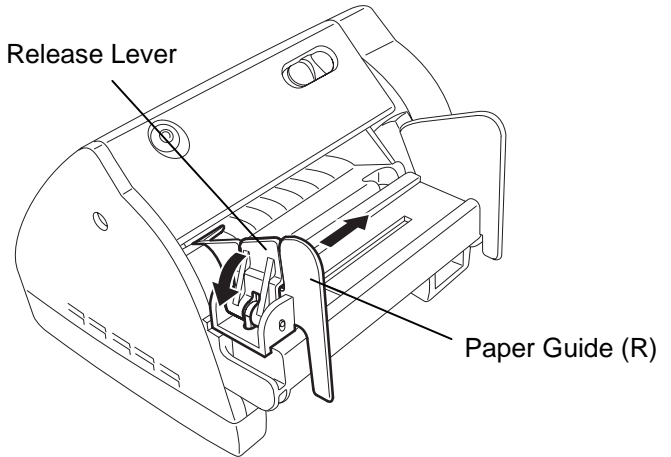

3. Remove the two screws to detach the Paper Guide Unit from the printer.

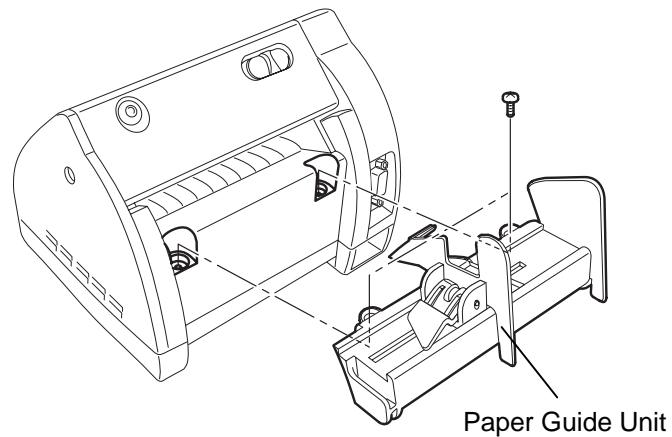

4. When changing the media to less than 4.2" (106 mm) wide one, install the Paper Guide Unit in the reverse order of removal described above.

**NOTE:**

*Be careful not to overtighten the screws of the Paper Guide Unit. The screw holes may be damaged.*

## 2.9 Test Print

The following test procedure allows you to perform a print test to verify that the printer is operating correctly.

1. Load the media on the printer.
2. Slide the Stand-by Switch to ON while holding the **[FEED]** button. The printer will start a status print.

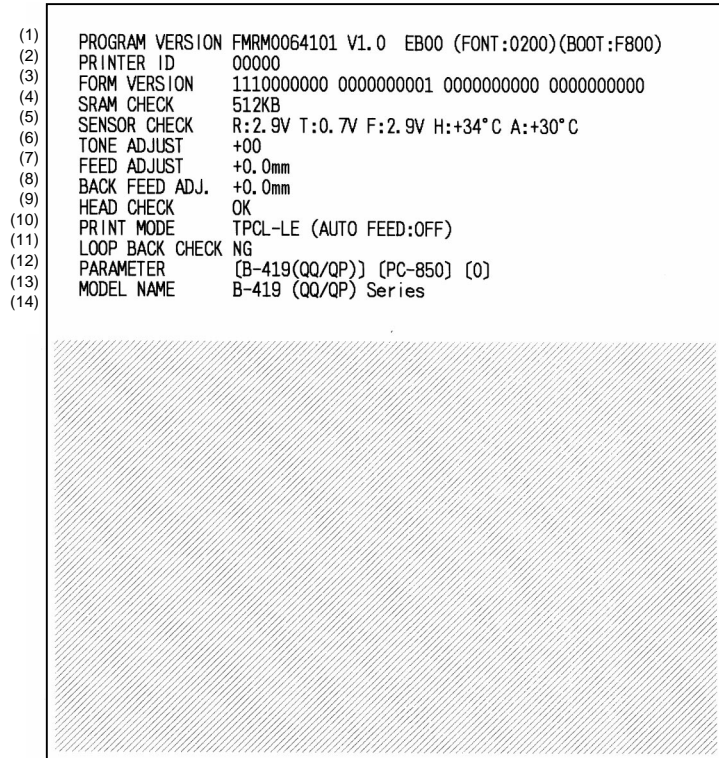

3. After completing the status print, the test pattern is printed each time the **[FEED]** button is pressed.

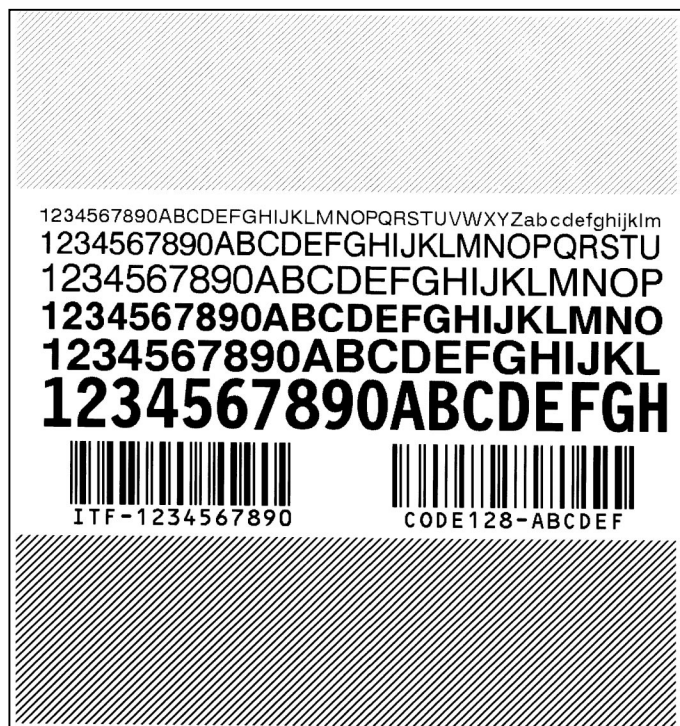

## 2.9 Test Print (Cont.)

### • Test Print Definitions

(1) Software Version and Checksums

PROGRAM VERSION FMRM0064101 V1.0 EB00 (FONT:0200) (BOOT: F800)

(2) Printer ID Number

PRINTER ID 00000

(3) Form Version No. 40

FORM VERSION 1110000000 0000000001 0000000000 0000000000

**NOTE:**  
Each form version: 0 to 9

(4) SRAM Capacity

SRAM CHECK 512KB

(5) Sensor Status

SENSOR CHECK R:2.9V T:0.7V F:2.9V H:+34°C A:+30°C

(6) Print Tone

TONE ADJUST +00

(7) Print Start Position

FEED ADJUST +0.0mm

## 2.9 Test Print (Cont.)

### (8) Back Feed Position

BACK FEED ADJ. +0.0mm

Back feed fine adjustment for the initial feed (-9.9mm to +9.9mm)

### (9) Print Head Element Check

HEAD CHECK OK

Result of print head broken elements check (OK: Normal, NG: Broken element)

### (10) Printing Mode

PRINT MODE TPCL-LE (AUTO FEED: OFF)

Auto feed function  
ON: with auto feed  
OFF: without auto feed

Issue mode  
TPCL-LE: TPCL-LE mode  
GRAPHIC: High speed graphic mode  
LABEL: Label issue mode  
RECEIPT: Receipt issue mode

**NOTE:**

For this check a loopback jig is required. Performing a loop back check without this jig will result in NG. For the loopback jig, please contact your nearest TOSHIBA TEC service representative.

### (11) Loop Back Check

LOOP BACK CHECK NG

Result of RTS-CTS loop back check  
OK: OK  
NG: NG

### (12) Printer Parameter

PARAMETER [B-419(QQ/QP)] [PC-850] [0]

Character code and font zero selection

### (13) Model Name

MODEL NAME B-419(QQ/QP) Series

May be changed by printer information registration procedure via download from PC.

### (14) Comment Print Area

COMMENT Jul/15/2001

Comment (Printed only when a comment was entered during the program download.)

**2.10 Program Download** This section provides step by step instructions on how to setup and download the firmware to the B-419 printer, and to make adjustments to the printer sensors. The firmware download and the sensor adjustments will be made from a Personal Computer via the RS-232C interface.

### 2.10.1 Outline of Features

The software for performing the program download will allow the download of the Firmware (Application Program including Boot Program, and Character Generator) from the provided FDK, allow adjustments to printer sensor sensitivity, and allow the download of the Printer Information. The software will be run on a standard PC and communication to the B-419 printer will be via the RS-232C cable.

**Firmware Download** - The Application Program, and Character Generator are installed into the B-419 printer's Flash memory prior to being shipped to the customer. However, if specifications should change at a later date, this software will allow downloading firmware updates to the B-419 printer.

**Sensor Adjustment** - The various sensors within the printer have been set at the factory before shipping. However, it may become necessary to make adjustments to the sensitivity of one or more of these sensors to compensate for factors such as different label backing paper thickness, opaqueness, etc. These adjustments can be made from a PC communicating with the B-419 printer via the RS-232C interface.

**Printer Information Registration** - This portion of the software allows you to download printer information from a standard PC to the printer's memory. The printer information consists of the model name and printer type. The printer will operate according to the selection of printer model and printer type. These data will print out on diagnostic labels issued from the printer.

**Test Print** - This portion of the software allows you to perform a test print from a PC.

### 2.10.2 Install Program Installation

Before you can communicate from your PC to the B-419 printer, you must first copy the "Install Program for B-419" from the three FDKs provided to the hard disk of your PC.

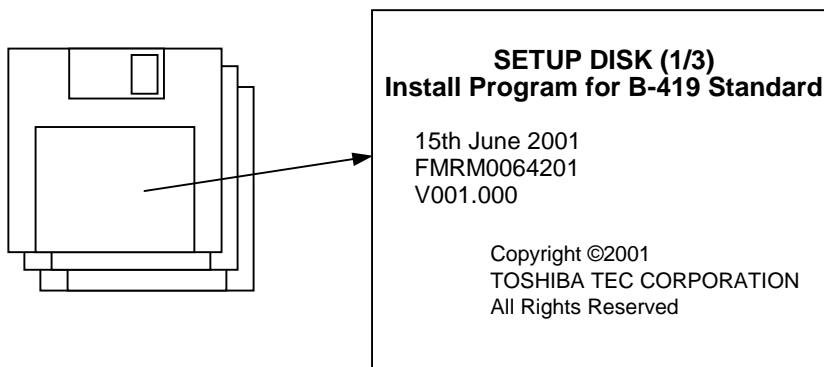

## 2.10.2 Install Program Installation (Cont.)

**NOTE:**

*Windows 3.1® is not supported. Windows 95®, Windows 98®, Windows 2000®, and Windows 3.1® are registered trademarks of the Microsoft Corporation.*

- **System Requirements**

**System**

IBM Compatible PC running Windows 95®, Windows 98®, or Windows 2000®.

Installed memory of 16MB minimum (32MB or more recommended)

Available Hard Disk space of 10MB or more

**Interface**

Interface to the B-419 will be through an RS-232C interface.

More than one serial port should be provided on the PC.

- **Setup**

**Setup Disk**

Make sure that you have all three diskettes available of the “Install Program for B-419”. (Refer to the figure on the previous page.)

1. While running Windows 95, Windows 98 or Windows 2000, insert Setup Disk (1/3) into the PC floppy drive.
2. Click on the **START** button then highlight **RUN** and click on **RUN**.
3. When the RUN display appears, type in A:\SETUP.EXE and click on **OK**.

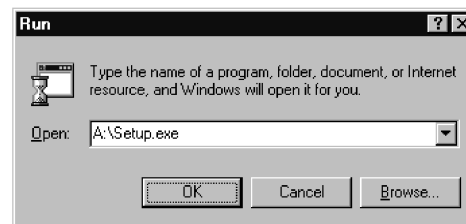

4. When the installation is ready, the initial screen of the installation will automatically appear.

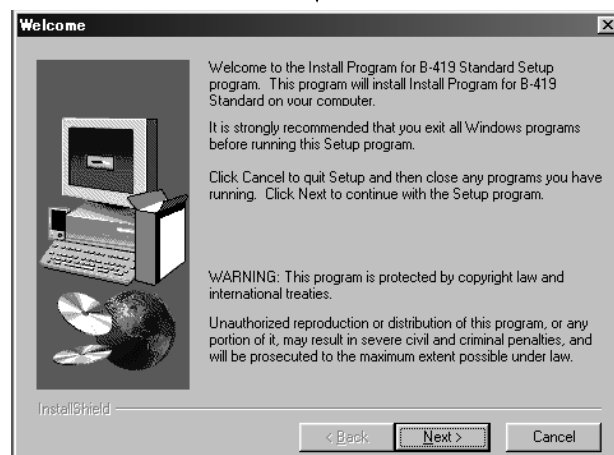
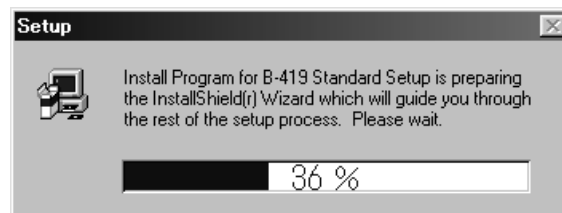



### 2.10.2 Install Program Installation (Cont.)

5. The Software License Agreement screen will appear. Click on **Yes** when you agree.

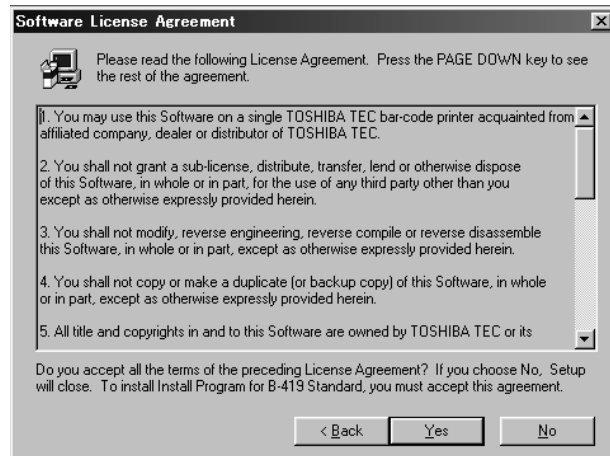

6. When the User Information screen appears, type in your name and company name, then proceed to the next step.



7. After click on **Next>** in the previous screen, the following message screen appears. Click on the **Next>** button to accept the directory or change the directory if desired.



### 2.10.2 Install Program Installation (Cont.)

8. The following program folder selection menu will appear. Click on the **Next>** button.



9. Confirm the current settings and click on the **Next>** button.



10. The install process will begin.  
11. When requested, insert Setup Disk (2/3) and then the Setup Disk (3/3).

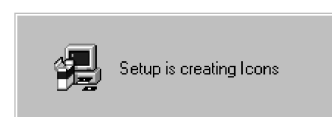

### 2.10.2 Install Program Installation (Cont.)

12. When the install process is completed, the following screen display will appear. Click on the **Finish** button to end the installation.



### 2.10.3 Firmware Files Copy

If it ever becomes necessary to upgrade the firmware in the B-419 printer you will be supplied with a floppy disk containing the latest firmware revision similar to that shown below.

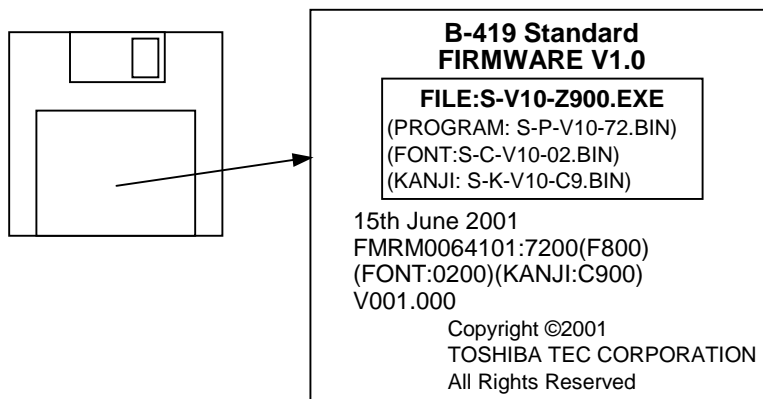

- **Copy Firmware Files to Hard Disk**

The files contained on the Firmware FDK are self-decompressing files. They must be copied to the following directories of the PC hard disk before being transferred to the printer. When the "Install Program for B-419" was installed onto your PC, it created the following directories:

**C:\Program Files\TOSHIBATEC\B419STDDL\Firmware**

Using Windows Explorer, copy all the files from the Firmware FDK to the above directory and decompress them into binary files (\*.BIN).

**NOTE:**

*If the Install Program for B-419 has not been installed on your PC yet, refer to Section 2.10.2 Install Program Installation and install it before copying the firmware.*

### 2.10.3 Firmware Files Copy (Cont.)

The following paragraphs will give step by step directions for running the "Install Program for B-419" on your PC which will allow you to transfer the binary files stored in directory **C: \Program Files\TOSHIBATEC\B419STDDL\Firmware** to the flash memory of the B-419 printer.

- **Running the Install Program for B-419**

1. Click on the **START** button to access the program menu.
2. Highlight "Programs" then highlight "TOSHIBA TEC" and click on Install Program for B-419 Series as shown in the screen display below

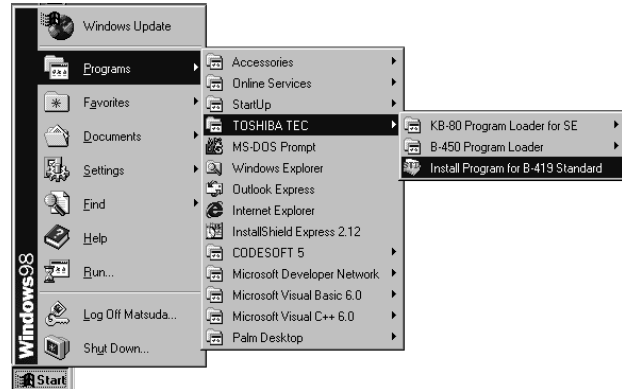

3. As soon as you click on Install Program for B-419, the screen will change to display the initial screen of the Install Program as shown below.

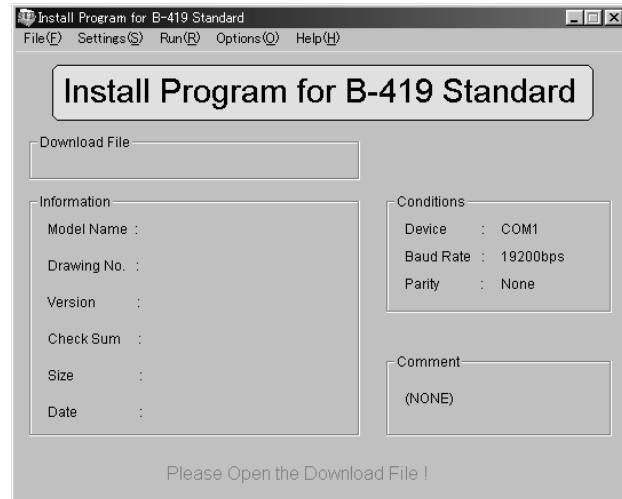

4. From the File (F) drop down menu select Open (O).

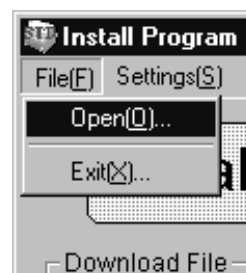

### 2.10.3 Firmware Files Copy (Cont.)

**NOTE:**

The C:\Program Files\  
TOSHIBATEC\B419STDDL  
\Firmware folder is the  
default directory.

5. The file open screen will appear as shown in the figure below. Select the **C:\Program Files\TOSHIBATEC\B419STDDL\Firmware** folder and the files in that folder will appear in the files box.

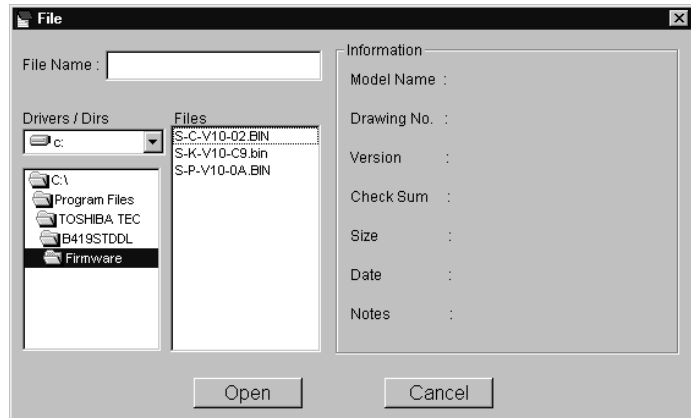

6. As soon as you highlight on the files in the files box, the right half of the screen will show all the data concerning the selected file as shown in the figure below.

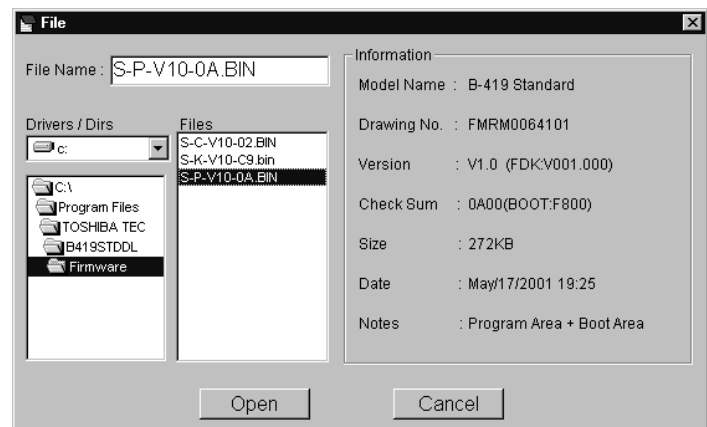

7. After highlighting the desired download file in the preceding screen display, click on **OPEN** and the screen display shown in the figure below will appear. Confirm the COM port conditions shown at the right of the screen.

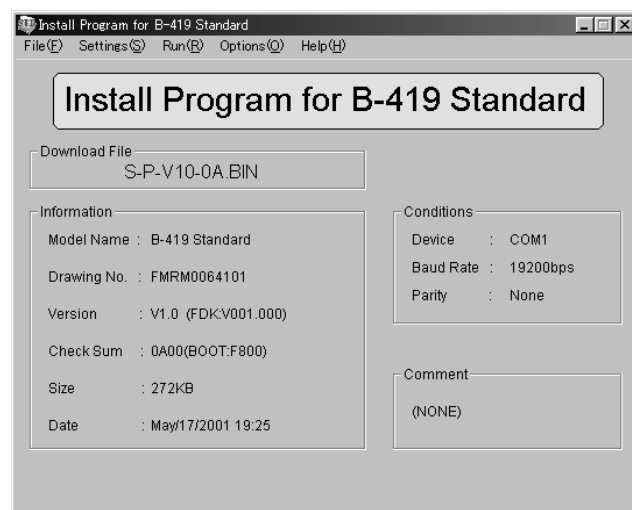

**2.10.3 Firmware Files Copy (Cont.)**

8. If it is necessary to change any of the communication parameters, select the Settings (S) drop down menu and then select Conditions (S) as shown in the figure below.

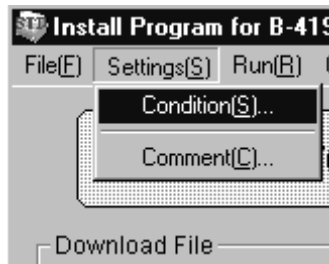

9. The communications setting window will appear as in figure below to allow you to change the communication parameters. Set the proper settings for Device, Parity, and Baud Rate, and click on **OK** button.

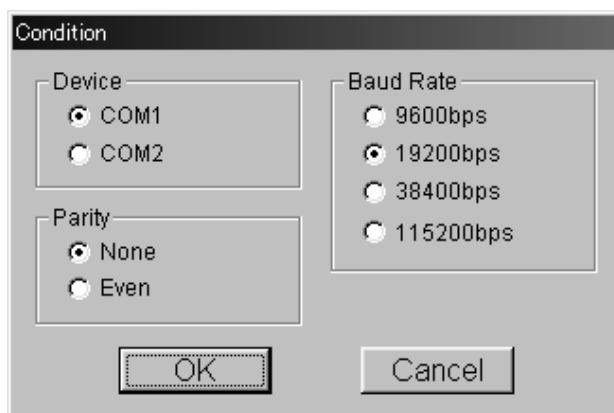

10. In the Settings drop down menu is another possible selection labeled Comment (C) as shown below. If Comment (C) is selected then the comment selection menu appears. There are three different settings that can be selected in this operation, Nothing, Only Date, and Enter Some Comments. If nothing is selected no comment is attached. If Only date is selected, then the PC date will be attached as the message. If Enter Some Comments is selected, a comment message of up to 16 characters can be attached to the download, and will appear on the diagnostic printout.

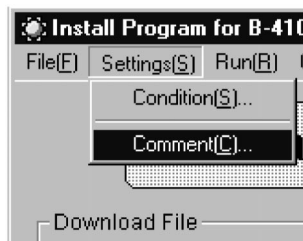

**NOTE:**

1. The communications settings should be set as follows.  
**Download:**  
 9600 bps to 115200 bps,  
 None parity  
**Sensor setting:**  
 19200 bps, None parity  
**Printer information registration:**  
 19200 bps, None parity  
**Test Print:**  
 19200 bps, None parity
2. The settings shown on the display are the default.

**NOTE:**

This procedure is only used by service personnel to download a message along with the firmware download. Be sure to select Nothing.

### 2.10.3 Firmware Files Copy (Cont.)

No comment will be sent.

**NOTE:**

When Nothing is selected, "(none)" will be displayed.

**Comment**

Nothing  
 Only Date  
 Enter Some Comments

Comment :

PC date will be sent.

**NOTE:**

When Only Date is selected, the current date will be displayed.

**Comment**

Nothing  
 Only Date  
 Enter Some Comments

Comment :

16 character maximum message can be sent.

**NOTE:**

When Enter Some Comments is selected, a message of max. 16 characters can be entered.

**Comment**

Nothing  
 Only Date  
 Enter Some Comments

Comment :

11. Click the **OK** button to continue.

- **Execution of Download to Printer**

1. After selecting a file for downloading in the previous steps, select the Run (R) drop down menu then select and click on START (R) as shown in the figure below.



**NOTE:**

If the file for downloading is not opened, START (R) cannot be selected.

**2.10.3 Firmware Files Copy (Cont.)**

- After clicking on Start in the previous screen, the following message will appear on the screen.

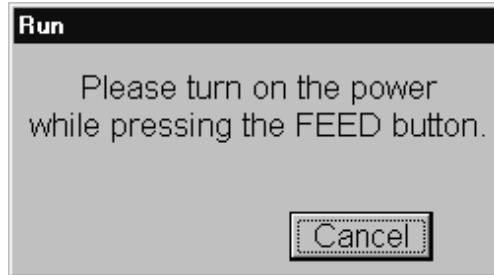

- At this time, connect the printer to the PC with the RS-232C cable. Press and hold the FEED button while sliding the printer Stand-by switch to ON. When the printer enters DOWNLOAD mode successfully, the message screen will change to the following.

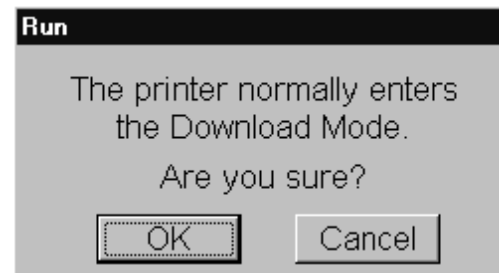

- Press the **OK** button on the preceding screen to begin the sending of the Firmware file. During transmission, the following screen appears with a progress indicator at the bottom.

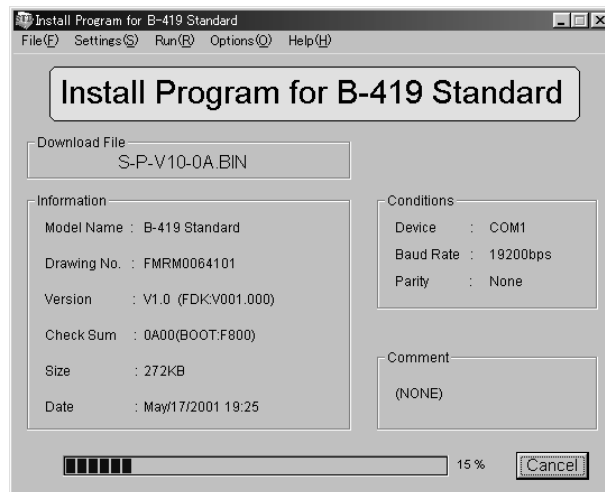

- When the file has been successfully transferred, the message shown below will appear.



**NOTE:**  
 If the message screen does not change, the printer failed to enter the DOWNLOAD mode. Turn on the printer power on while pressing and holding the FEED button again.

**NOTE:**  
 If an error occurs during download or at the end of download, retry from step 1.



### 2.10.4 Sensor Adjustments

#### NOTES:

1. These sensors have been factory set so it is not advisable for you to make these adjustments unless you are having a problem with the printer.
2. If the sensor adjustment is required, be sure to follow the procedure as described. Failure to do this may cause a malfunction of the printer.
3. Do not turn on the printer with the media being set in the printer. Doing so causes the printer to feed the media automatically, and you cannot adjust the sensor. To inactivate the auto feed function during the sensor adjustment, turn the printer power on with no media or with the media cover open, and then click on **Read A/D** button.

Through the following procedure, it is possible to adjust the sensitivity of the three sensors in the B-419 printer from your PC via the RS-232C interface. The three sensors are the reflective (black mark) sensor, the transmissive (feed gap) sensor, and the paper end sensor.

#### • Setup

To begin the sensor adjustment operation, you will need to turn on the power of the B-419 printer (do not hold the feed key this time). Connect the printer to the PC with the RS-232C cable. Select the TPCL-LE mode for the printer issue mode. Then set the communications parameters as follows:

**19200 bps, None parity**

#### • Start

1. From the Install Program for B-419 main menu, select Options (O) then select Sensor Adjustment (S) as shown in the figure below.

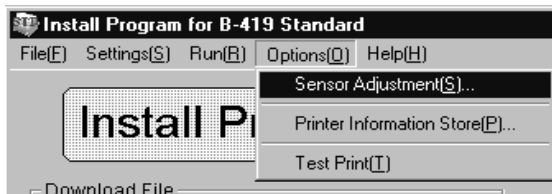

2. After highlighting and clicking on Sensor Adjustment (S) from the above display, the screen display will change to the Sensor Adjustment menu. Click on the **Read A/D** button. The screen will now display the current sensor output values.

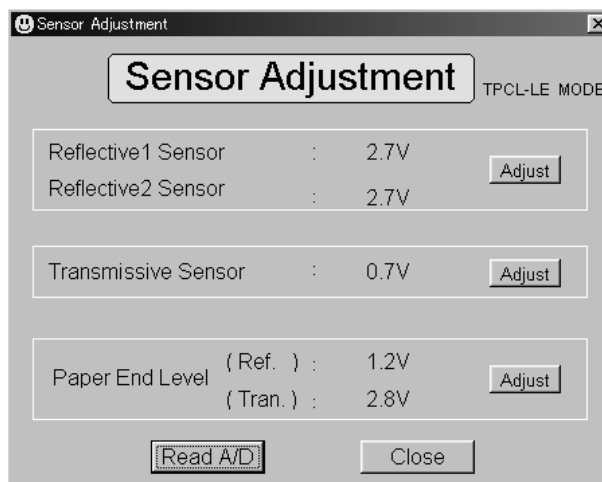

### 2.10.4 Sensor Adjustments (Cont.)

#### • Adjustment Procedure

##### Reflective Sensor (Black Mark Sensor)

1. The reflective sensor is the one used to detect the black mark on the back of certain types of print media. Place the media so that the white part of the media (not the black mark) is positioned on the sensor.
2. From the Sensor Adjustment menu shown on the previous screen, click on the **Adjust** button for the reflective sensor. The screen display shown in the figure below will appear.

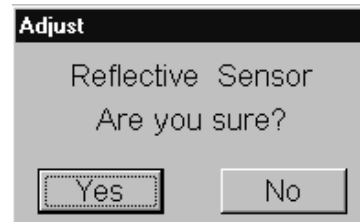

3. Click on the **Yes** button and the sensitivity of the reflective sensor will automatically be set as indicated by the "Now Adjusting" window appearing as shown in the figure below.

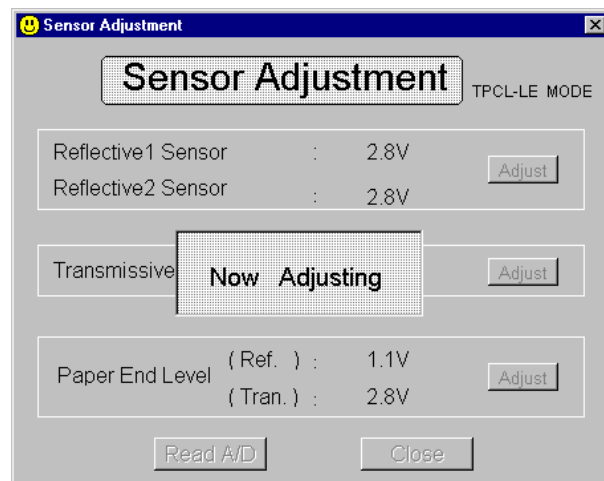

#### **NOTE:**

After completing an adjustment to any of the sensors the **Adjust** button will become greyed out. However, it will still be possible to make the adjustment again even if the **Adjust** button is greyed out.

##### Transmissive Sensor (Feed Gap Sensor)

1. The transmissive sensor is the one used to detect the gap between labels. It detects the transmission of light through the backing paper of different opaqueness. Place the media so that the backing paper (not the label) is positioned over the transmissive sensor.
2. From the Sensor Adjustment menu shown on the previous page, click on the **Adjust** button for the transmissive sensor. The screen display shown in the figure below will appear.

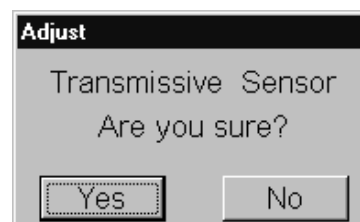

### 2.10.4 Sensor Adjustments (Cont.)

- Click on the **Yes** button and the sensitivity of the transmissive sensor will automatically be set as indicated by the “Now Adjusting” window appearing as shown in the figure below.

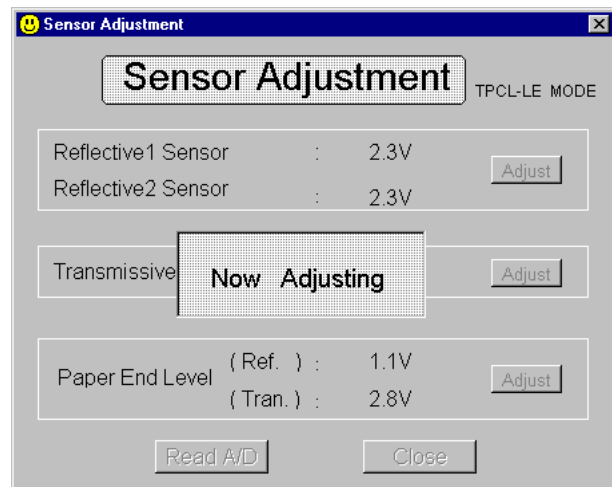

#### Paper End Sensor

- The paper end sensor will detect when the print media has run out. To adjust this sensor, remove the media from the printer and click on the **Adjust** button for the paper end level sensor on the Sensor Adjustment menu.
- The screen display shown in the figure below will appear.

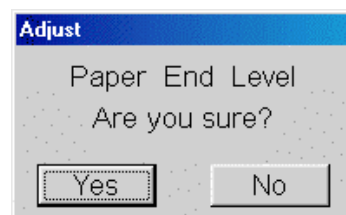

- Click on the **Yes** button and the sensitivity of the paper end sensor will automatically be set as indicated by the “Now Adjusting” window appearing as shown in the figure below.

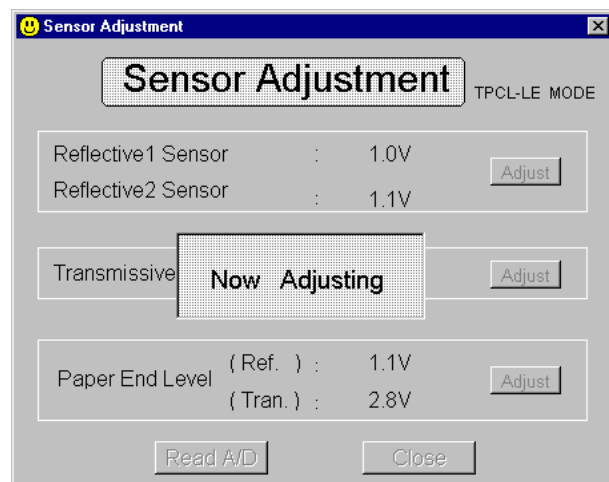

### 2.10.5 Printer Information Registration

**NOTE:**

*This information is stored in printer memory before delivery to the customer, so this procedure need only be done if it is required to change any of the information.*

This procedure will be used to register (transfer) printer information to the printer memory and the information registered here will also be printed on every diagnostic print issued from the printer. The information to be registered will be the printer model name and the printer type.

- **Procedures**

1. To perform this operation, you will need to turn on the power of the B-419 printer (do not hold the feed key this time). Connect the printer to the PC with the RS-232C cable. Select the TPCL-LE mode for the printer issue mode. Then set the communications parameters as follows:

**19200 bps, None parity**

2. From the Install Program for B-419 main menu, select Options (O) and Printer Information Store (P) as shown in the screen display of the figure below.

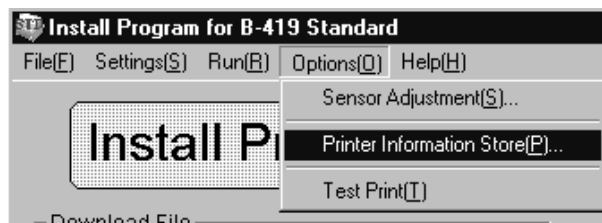

**NOTE:**

*When the entire serial number is entered, the printer ID will appear automatically.*

3. After selecting Printer Information Store (P), the screen will change to the display shown below.

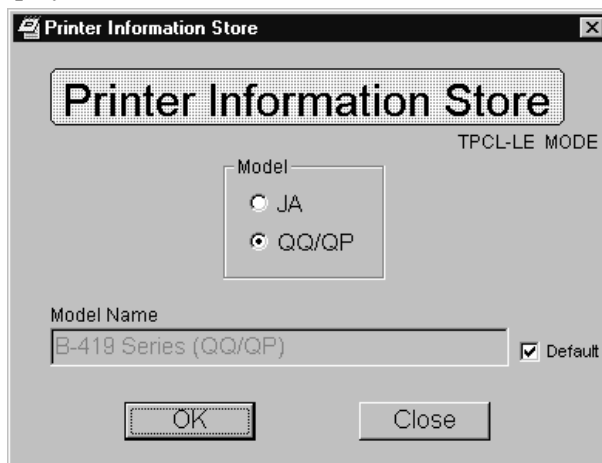

### 2.10.5 Printer Information Registration (Cont.)

**NOTE:**

*Model Name is automatically displayed by selecting the Model. To change the Model Name click on the Default check box to remove the check mark and it will then be possible to type in a new Model Name of up to 20 characters.*

4. Click on the QQ/QP check box for the Model on the Printer Information Store display. Depending on the selected model, the printer changes the communication requirements and other internal functions.

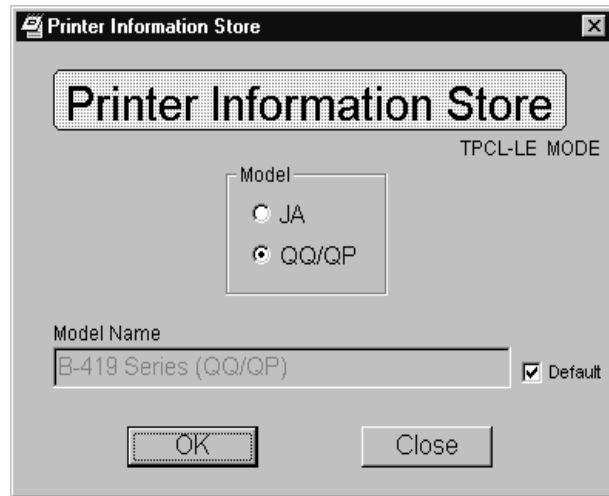

5. When the desired changes have been made, click on the **OK** button and the following screen display will appear. Confirm the printer information on the screen display, and click on **Yes** to start registration.

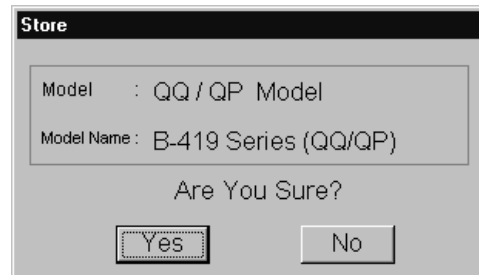

**NOTE:**

*If the Complete screen does not appear, retry from step 1.*

6. When the registration terminates successfully, the following display will appear.

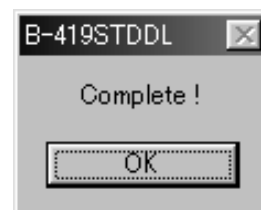

### 2.10.6 Test Print

This procedure will be used to perform a test print.

- **Procedures**

1. To perform this operation, you will need to turn on the power of the B-419 printer (do not hold the feed key this time). Connect the printer to the PC with the RS-232C cable. Select the TPCL-LE mode for the printer issue mode. Then set the communications parameters as follows:

**19200 bps, None parity**

2. From the Install Program for B-419 main menu, select Options (O) and Test Print (T) as shown in the screen display of the figure below.

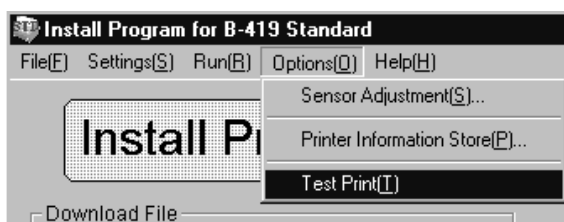

3. When the following screen display appears, set the Label Pitch, Print Count, and the Sensor, then click on the **OK** button.

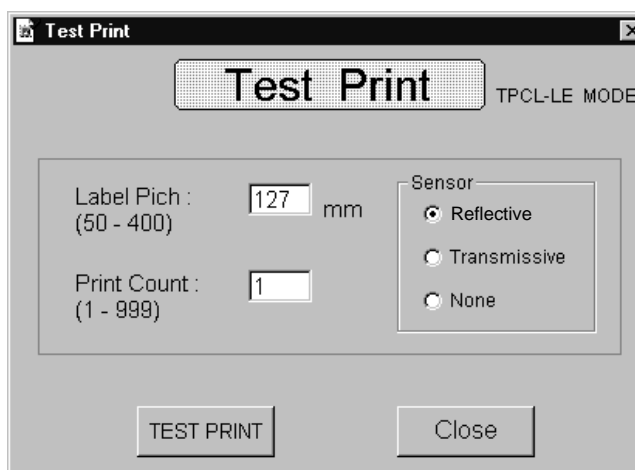

A few seconds later, the printer will start the test print.



**NOTES:**

1. The default settings are:  
Label Pitch: 127 mm  
Print Count: 1  
Sensor: Reflective
2. The size of the print image for the test print has been designed to fit to a 127 mm pitch label. Therefore, when using the paper of shorter pitch, the print image will break, or when using the label of longer pitch, a blank space will remain.
3. Setting the different label pitch from actual paper size or using the paper with a black mark printed on an improper position may cause an error.

### 2.10.7 Version Display

This procedure will be used to check the version of the Install Program for B-419 Standard.

- **Procedures**

1. From the Install Program for B-419 main menu, select Help (H) and Version (A) as shown in the screen display of the figure below.



2. The Version screen display will appear as follows.



## 3. MAINTENANCE

### WARNING!

1. Be sure to disconnect the Power Cord before performing maintenance. Failure to do this may cause an electric shock.
2. To avoid injury, be careful not to pinch or jam your fingers while opening or closing the cover.
3. The Print Head may become hot. Do not touch the Print Head.
4. Do not pour water directly onto the printer.

This chapter describes how to perform normal maintenance.

To maintain the printer performance and quality print, please clean the printer regularly, or whenever media is replaced.

### 3.1 Cleaning

The following sections describe periodic cleaning of the unit.

#### 3.1.1 Print Head/Platen

### CAUTION!

1. Do not allow any hard objects to touch the print head or platen, as this may cause damage to them.
2. Do not use any volatile solvent including thinner and benzene, as this may cause discoloration to the cover, print failure, or breakdown of the printer.
3. Do not touch the print head element with bare hands, as static may damage the print head.
4. Failure to clean the print head may cause a print head problem, shortening its life.
5. Failure to clean the platen may cause the platen to slip, resulting in a feed error.

### NOTE:

For cleaning the print head, TOSHIBA TEC-approved print head cleaner is recommended. It is available at your nearest TOSHIBA TEC sales agent.  
Part Name: Print Head Cleaner  
Part No.: 24089500013

1. Disconnect the Power Cord. Open the Media Cover.
2. Remove the media from the printer.
3. Clean the Print Head Element with the Print Head Cleaner or a cotton swab slightly moistened with ethyl alcohol.

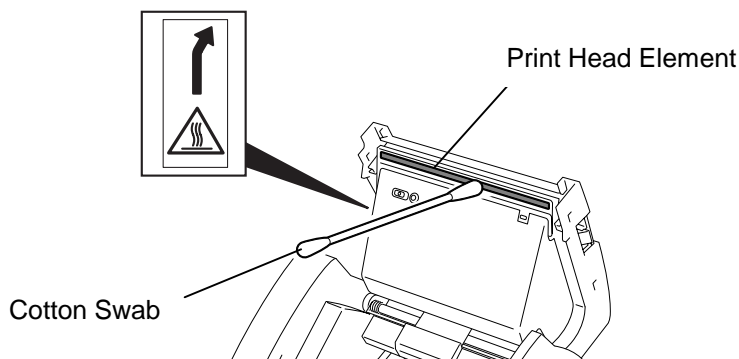

4. Wipe the Platen with a soft cloth slightly moistened with ethyl alcohol.

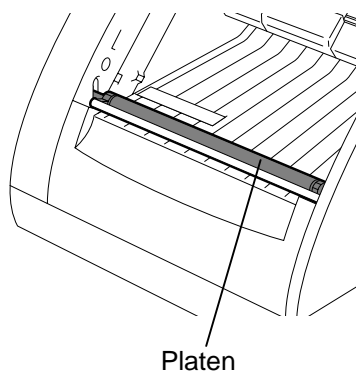



### 3.1.2 Paper Path/Sensors

1. Wipe the Paper Path and Sensor Window with a dry soft cloth.

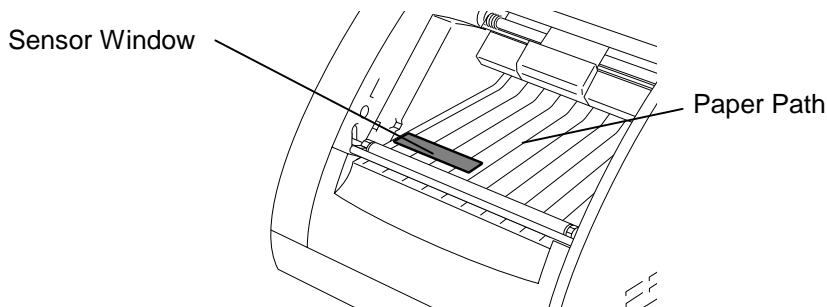

2. Remove dust from the Media Sensor with a brush or equivalent.

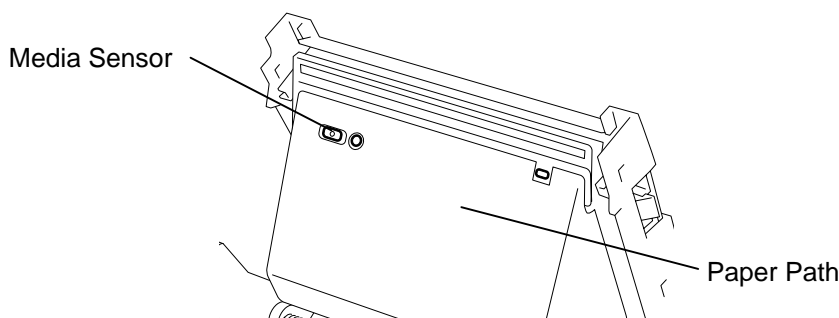

### 3.1.3 Covers

**CAUTION!**

Do not use any volatile solvent including thinner and benzene, as this may cause discoloration or distortion of the cover.

Wipe the Cover with a dry soft cloth. Wipe off dirt with a soft cloth slightly moistened with water.

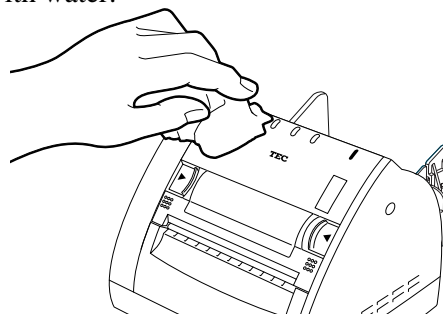

## 3.2 Care/Handling of the Media

**CAUTION!**

Be sure to read carefully and understand the Supply Manual. Use only media which meet specified requirements. Use of non-specified media may shorten the head life and result in problems with bar code readability or print quality. All media should be handled with care to avoid any damage to the media or printer. Read the guideline in this section carefully.

- Do not store the media for longer than the manufacturer's recommended shelf life.
- Store media rolls on the flat end. Do not store them on the curved sides as this might flatten that side causing erratic media advance and poor print quality.
- Store the media in plastic bags and always reseal after opening. Unprotected media can get dirty and the extra abrasion from the dust and dirt particles will shorten the print head life.
- Store the media in a cool, dry place. Avoid areas where they would be exposed to direct sunlight, high temperature, high humidity, dust or gas.
- The thermal paper used for direct thermal printing must not have specifications which exceed  $\text{Na}^+$  800 ppm,  $\text{K}^+$  250 ppm and  $\text{Cl}^-$  500 ppm.
- Some ink used on pre-printed media may contain ingredients which shorten the print head's product life. Do not use labels pre-printed with ink which contain hard substances such as carbonic calcium ( $\text{CaCO}_3$ ) or kaolin ( $\text{Al}_2\text{O}_3$ ,  $2\text{SiO}_2$ ,  $2\text{H}_2\text{O}$ ).

For further information, please contact your local distributor or your media manufacturers.

## 4. TROUBLESHOOTING

This chapter lists the error messages and possible problems and their solutions.

### WARNING!

If a problem cannot be solved by taking actions described in this section, do not attempt to repair the printer. Turn off and unplug the printer, then contact an authorized TOSHIBA TEC representative for assistance.

### 4.1 LED State

When a problem occurs during operation, the LED indicator will light or flash. Refer to the following troubleshooting guide and take corrective action.

○:LED off, ●: LED on, ✨: LED flashing

Printer Status	LED State			Condition to clear the ERROR Status
	ON LINE*5	DATA	ERROR*1	
When the power is turned on.	●	●→○ (2 or 3 seconds)	●→○ (2 or 3 seconds)	
Normal condition (Idle)	●	○	○	
While the cover is open.	●	○	○	
Command error	●	○	✨	Turn the Stand-by switch OFF and then ON, or close the cover.
Feed jam *3	●	✨	✨	Close the cover after loading media.
Media end *3	●	✨	✨	Close the cover after loading media.
Cover open error *3	●	✨	✨	Close the cover.
Print head broken element error	●	○	●	*6
Print head overheat *3	●	✨	✨	Stop printing for a while.
Flash ROM data write error	●	○	✨	*6
Flash ROM data erasing error	●	○	✨	*6
In action *4	●	●	○	
Communication error	●	○	✨	Close the cover.
Wait for issue (Wait for the media supply) *2	●	✨	○	Close the cover after loading media.
Form entry area in the flash ROM becomes full.	●	○	✨	Form entry, area format
No paper (Idle)	●	○	○	Load media.
Normal end	●	○	○	

#### NOTES:

- \*1. The ERROR LED flashes at the interval of 0.1 sec.
- \*2. When the printer waits for the media supply, the DATA LED flashes slowly (ON for 1 sec. and OFF for 0.5 sec.). When the media runs out in the middle of printing, the DATA LED flashes slowly, also. The printer will restart printing after the media is supplied.
- \*3. When these errors occur during printing, the DATA LED flashes slowly (ON for 1 sec. and OFF for 0.5 sec.). The printer will restart the printing after clearing the error. However, the printer does not restart after clearing these errors if they occur during the media feed. In this case, the DATA LED does not flash.
- \*4. While the printer is communicating with the PC, the DATA LED flashes fast (at the interval of 0.05 sec.).
- \*5. The ON LINE LED is always illuminated while the Stand-by Switch is turned ON.
- \*6. Please contact an authorized TOSHIBA TEC representative.

## 4.2 Error Process

When the printer detects the errors shown below, it sends the error state to the PC by the ERROR LED and DATA LED, and stops the operation, waiting for a command from the PC or a restart.

The printer will restart the operation after clearing a feed jam, media end, cover open, or print head overheat error which occurs during printing, or after supplying the media when the printer has run out. For all other errors, however, the printer does not restart the operation after clearing the error, it is necessary to resend the command. Regarding the print head broken element error, the printer stops every operation except a status response.

1. Command error
  - (1) This error occurs if an error in the command length, the command transmission sequence, the command format, or the parameter designation is found during the command analysis.
  - (2) This error occurs if the form No. designated by the data print command has not been registered.
2. Feed Jam (Paper Feed Error)
  - (1) This error occurs if the printer fails to detect the gap between labels even after feeding the label for 1.5 times as long as the label pitch designated by the label size setting command. (Only when the feed gap sensor/black mark sensor is designated.)
  - (2) This error occurs if the printer fails to detect the black mark for the auto feed function even after feeding the media for 180 mm when supplying the media, turning the Stand-by switch ON, or closing the cover.
3. Media End

This error occurs if the printer detects the label end for 20 mm during label issue or feed. However, if more than 90% of effective print length has been printed and no more print data remains, the printing terminates normally. Also, if a media end is detected in the middle of printing and unprinted data remains, the printer is in the state waiting for issue (wait for media supply).

**NOTE:** *Detecting a media end state during media feed results in no error.*
4. Cover Open error
  - (1) This error occurs if a cover open state is detected while the printer is printing or issuing the media for 5 mm.
  - (2) This error occurs if a media issue or feed is attempted while the media cover is opened.
5. Print Head Broken Element error
  - (1) This error occurs if a broken element is detected during the automatic missing dot check which is performed when the Stand-by switch is turned on or the cover is closed.
  - (2) This error occurs if an error occurs in the print head driver.
6. Print Head Overheat

This error occurs if the thermistor of the print head detects abnormally high temperature.
7. Flash ROM Data Write Error

This error occurs if an error occurs when data is written into the flash ROM.
8. Flash ROM Data Erasing Error

This error occurs if an error occurs when the flash ROM is initialized (data erasing).
9. Wait for issue (Wait for media supply)
  - (1) This error occurs if a print command is received when the media has run out.
  - (2) This error occurs if more than 90% of effective print length has been printed and unprinted data remains in the media end state. For example, when issuing some cut forms, the media needs to be supplied one by one. Then, the printer's wait for issue state is sent to the PC each time a cut form is issued. Printing terminates normally when the last label is issued, as no more data remains.
10. Area Full in the Flash ROM
  - (1) This error occurs when the form entry area in the flash ROM becomes full.
  - (2) This error occurs when the data of 4KB or more is sent when the form entry is performed while the form No. "00" is designated.

**NOTE:** *When an undefined instruction execution error occurs, the printer will be automatically reset.*

### 4.3 Possible Problems

This section describes problems that may occur when using the printer, and their causes and solutions.

Possible Problems	Causes	Solutions
The printer will not turn on.	<ol style="list-style-type: none"> <li>1. The Power Cord is disconnected.</li> <li>2. The AC outlet is not functioning correctly.</li> <li>3. The fuse has blown, or the circuit breaker has tripped.</li> </ol>	<ol style="list-style-type: none"> <li>1. Plug in the Power Cord.</li> <li>2. Make sure that the power is supplied using another electric appliance.</li> <li>3. Check the fuse or breaker.</li> </ol>
The media is not fed.	<ol style="list-style-type: none"> <li>1. The media is not loaded properly.</li> <li>2. The printer is in an error condition.</li> </ol>	<ol style="list-style-type: none"> <li>1. Load the media properly.</li> <li>2. Solve the error indicated by the LED state. (See Section 4.1. LED State.)</li> </ol>
Nothing is printed on the media.	<ol style="list-style-type: none"> <li>1. The media is not loaded properly.</li> <li>2. The media cover is not closed properly.</li> <li>3. Improper media is used.</li> </ol>	<ol style="list-style-type: none"> <li>1. Load the media properly.</li> <li>2. Close the Media Cover completely.</li> <li>3. Use the specified media.</li> </ol>
The printed image is blurred.	<ol style="list-style-type: none"> <li>1. Improper media is used.</li> <li>2. The Print Head is not clean.</li> </ol>	<ol style="list-style-type: none"> <li>1. Use the specified media.</li> <li>2. Clean the print head using the Print Head Cleaner or a cotton swab slightly moistened with ethyl alcohol.</li> </ol>

### 4.4 Removing Jammed Media

This section describes how to remove jammed media from the printer.

**CAUTION!**

*Do not scratch the Print Head or Platen using a sharp instrument, as this may cause media feed failure or damage to the printer.*

1. Open the Media Cover.
2. Remove the jammed media.
3. Clean the Platen and sensors as described in Section 3.1.

## APPENDIX 1 SPECIFICATIONS

Appendix 1 describes the specifications of the printer and supplies for use on the B-419 printer.

### A1.1 Printer

The following is the printer specifications.

Item	Model	B-419-GS10-QQ
Supply voltage		AC120V, 60 Hz
Power consumption		0.7 A, 55 W maximum during a print job 0.05 A, 4 W maximum during standby
Operating temperature range		32°F to 104°F (0°C to 40°C)
Relative humidity		25% to 85% RH (no condensation)
Resolution		203 dpi (8 dots/mm)
Printing method		Thermal direct
Printing speed		Max. 2"/sec. (50.8 mm/sec.)
Available media width (including backing paper)		1.3" to 4.2" (33 mm to 106 mm) When the Paper Guide Unit is removed, up to 4.3" (109 mm) wide media is acceptable.
Effective print width (max.)		4.1" (104 mm)
Issue mode		Batch
Dimension (W × D × H)		6.6" × 7.4" × 5.1" (167 mm × 187 mm × 130 mm)
Weight		1.6 kg (3.53 lb) (Media is not included.)
Available bar code types		JAN8, JAN13, EAN8, EAN13, UPC-E, UPC-A, MSI, NW-7, CODE39, CODE128, EAN128, Interleaved 2 to 5, Customer Bar Code, Customer Bar Code of high priority
Available two-dimensional code		Data Matrix, PDF417, QR code, Maxi Code, Micro PDF417
Available bar font		Times Roman (6 sizes), Helvetica (6 sizes), Presentation (1 size), Letter Gothic (1 size), Prestige Elite (2 sizes), Courier (2 sizes), OCR (2 types), Outline font (2 types), Price font (2 types), BRUSH 738 Regular, DUTCH 801 Bold, GOTHIC 725 Black, Standard Character, Bold Character
Rotations		0°, 90°, 180°, 270°
Standard interface		Serial interface (RS-232C)

#### NOTES:

- *Data Matrix™* is a trademark of International Data Matrix Inc., U.S.
- *PDF417™* is a trademark of Symbol Technologies Inc., US.
- *QR Code* is a trademark of DENSO CORPORATION.
- *Maxi Code* is a trademark of United Parcel Service of America, Inc., U.S.

## A1.2 Media

Please make sure that the media that will be used is approved by TOSHIBA TEC. The warranty does not apply when a problem is caused by using media that is not approved by TOSHIBA TEC.

For information regarding TOSHIBA TEC approved media, please contact a TOSHIBA TEC service representative.

### A1.2.1 Media Type

Cut form and fanfold paper can be used. The table below shows the size and shape of the media available for this printer.

#### Cut Form

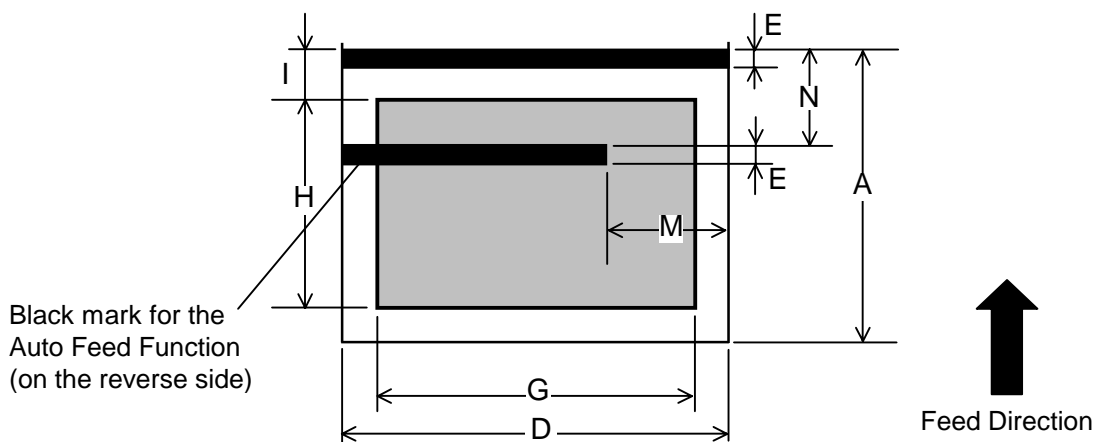

Unit: Inch + (mm)

Item	Cut Form
A: Media pitch	4.7 – 15.7 (120 – 400)
D: Media width	1.3 – 4.2, *4.3 (33 – 106, *109)
E: Gap/Black mark length	0.1 (3)
G: Effective print width	0.9 – 4.1 (22 – 104)
H: Effective print length	Max. 15.4 (390)
I: Non print area	0.3 (6.4)
M: Black mark prohibited area for the auto feed function	1.0 (26)
N: Black mark position for the auto feed function	1.4 (35)

\*: When the paper guide unit is removed.

#### Fanfold Paper

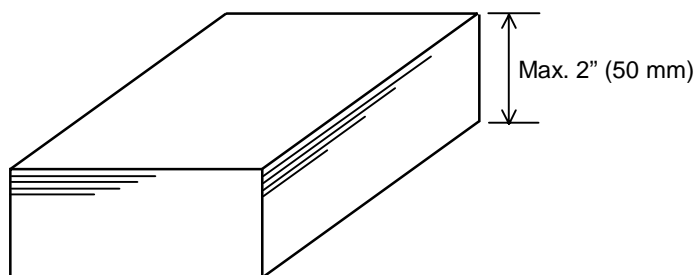

## APPENDIX 2 INTERFACE

### ■ Interface Cables

To prevent radiation and reception of electrical noise, the interface cables must meet the following requirements:

- Fully shielded and fitted with metal or metallized connector housings.
- Keep as short as possible.
- Should not be bundled tightly with power cords.
- Should not be tied to power line conduits.

### ■ RS-232C Cable description

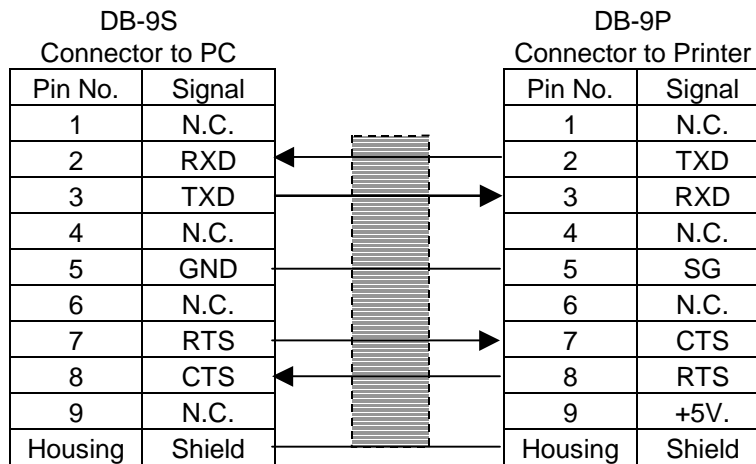

#### NOTES:

1. Use an RS-232C cable with imperial type securing screws on the connector.
2. Pin No. 9 of the printer side connector is supplied with the +5V (max. 100 mA) power from the printer.

## APPENDIX 3 PRINT SAMPLES

### ■ Bit Map Font

<A>Times Roman medium:12point

<B>Times Roman medium:15point

<C>Times Roman bold:15point

<D>Times Roman bold:18point

<E>Times Roman bold:21point

<F>Times Roman italic:18point

<G>Helvetica medium:9point

<H>Helvetica medium:15point

<I>Helvetica medium:18point

<J>Helvetica bold:18point

<K>Helvetica bold:21point

<L>Helvetica italic:18point

<M>PRESENTATION BOLD:27POINT

<N>Letter Gothic medium:14.3point

<O>Prestige Elite medium:10.5point

<P>Prestige Elite bold:15point

<Q>Courier medium:15point

<R>Courier bold:18point

<S>OCR-A 12POINT

<T>OCR-B 12POINT

(a)Standard:12x24dots

(b)Bold **1234567890**

(d)Price Font1 1234567890

(e)Price Font2 **1234567890**

<o>Gothic 725 Black:6point

### ■ Outline Font

<A>Outline Font TEC Font 1

<B>Outline Font TEC Font1(Proportional)

<H>Outline Font DUTCH 801 Bold

<J>Outline Font BRUSH 738 Regular

<J>Outline Font GOTHIC 725 Black



# APPENDIX 3 PRINT SAMPLES (Cont.)

■ Bar codes

0: JAN8, EAN8



1: MSI



2: Interleaved 2 of 5



3: CODE39 (Standard)



4: NW7



5: JAN13, EAN13



6: UPC-E



7: CODE128



8: UPC-A



9: EAN128



10: PDF417



11: Data Matrix



12: Customer bar code



13: Customer bar code of high priority



14: QR code



15: Micro PDF417



16: MaxiCode



## GLOSSARIES

### **Bar code**

A code which represents alphanumeric characters by using a series of black and white stripes in different widths. Bar codes are used in various industrial fields: Manufacturing, Hospitals, Libraries, Retail, Transportation, Warehousing, etc. Reading bar codes is a fast and accurate means of capturing data while keyboard entry tends to be slow and inaccurate.

### **Batch mode**

Issue mode that continuously prints media until the specified number of media has been printed.

### **Black mark**

A mark printed on the media so that the printer can maintain a constant print position by detecting this mark.

### **Black mark sensor**

A reflective sensor which detects the difference of potential between the black mark and print area to find the print start position.

### **DPI**

Dot Per Inch

The unit used to express print density.

### **Feed gap sensor**

A transmissive sensor which detects the difference of potential between the gap between labels and the label to find the print position of the label.

### **Font**

A complete set of alphanumeric characters in one style of type. E.g. Helvetica, Courier, Times, etc.

### **Gap**

Clearance between labels

### **IPS**

Inch per second

The unit used to express print speed.

### **Label**

A type of media with adhesive backing.

### **Media**

Material on which data is printed by the printer. Label, tag paper, fanfold paper, perforated paper, etc.

### **Pre-printed media**

A type of media on which characters, logos, and other designs have been already printed.

### **Print head**

A print head that prints on the thermal media which reacts to heat by supplying the thermal elements with current causing the thermal element to heat up.

### **Print head element**

The thermal print head consists of a single line of tiny resistive elements and when current is allowed to flow through each element it heats up causing a small dot to be burned onto thermal paper.

### **Printing speed**

The speed at which printing occurs. This speed is expressed in units of ips (inches per second).

### **Resolution**

The degree of detail to which an image can be duplicated. The minimum unit of divided image is called a pixel. As the resolution becomes higher, the number of pixels increased, resulting in more detailed image.

### **Tag**

A type of media having no adhesive backing but black marks to indicate the print area. Usually tags are made of cardboard or other durable material.

### **Thermal direct printing**

A printing method using no ribbon, but thermal media which reacts to heat. The thermal print head heats the thermal media directly, causing print image to be printed on the media.

# INDEX

## A

Auto Feed 2-8

## B

Bar code A1-1  
Black mark 2-8, A1-2  
Black mark length A1-2  
Black mark sensor 1-3

## C

Cut form 1-1, 2-6, 2-8, A1-2

## D

Dimensions 1-2, A1-1  
DATA LED 1-4, 4-1

## E

Effective print width A1-2  
ERROR LED 1-4, 4-1

## F

Fanfold paper 2-6, 2-7, A1-2  
FEED button 1-3, 1-4  
Feed gap sensor 1-3

## G

Gap length A1-2

## I

Interface A1-1  
Issue mode A1-1

## J

Jammed media 4-3

## M

Media 2-6, 3-2, A1-2  
Media cover release catch 1-3, 2-5  
Media pitch A1-2  
Media width A1-1, A1-2

## O

ON LINE LED 1-4, 4-1

## P

Paper guide 1-3, 2-7, 2-8, 2-9  
Paper guide release lever 2-7, 2-8  
Platen 1-3, 3-1  
Power consumption A1-1  
Power cord 1-2, 2-3  
Pre-printed media 3-2  
Print head 1-3  
Print head cleaner 3-1  
Print head element 3-1  
Print length A1-2  
Printing method A1-1  
Printing speed A1-1

## R

Resolution A1-1  
Rotations A1-1  
RS-232C 1-3  
RS-232C Cable 2-2, A2-1

## S

Sensor window 3-2  
Serial interface 1-3  
Stand-by switch 1-3, 1-4, 2-3, 2-4  
Supply voltage A1-1

## T

Test print 2-10  
Thermal direct A1-1  
Thermistor 1-3  
TPCL-LE mode 1-1, 2-23, 2-26, 2-28  
Two-dimensional code A1-1

## W

Weight A1-1







***TEC***

**TOSHIBA TEC CORPORATION**

**E** PRINTED IN JAPAN  
EO1-33030

## Free Manuals Download Website

<http://myh66.com>

<http://usermanuals.us>

<http://www.somanuals.com>

<http://www.4manuals.cc>

<http://www.manual-lib.com>

<http://www.404manual.com>

<http://www.luxmanual.com>

<http://aubethermostatmanual.com>

Golf course search by state

<http://golfingnear.com>

Email search by domain

<http://emailbydomain.com>

Auto manuals search

<http://auto.somanuals.com>

TV manuals search

<http://tv.somanuals.com>