

Satellite[®] A20/A25 Series Resource Guide

NOTE

Keep this guide in a convenient place to access important information about your computer.

If you need assistance, contact the following:

InTouch[®] Center

Calling within the United States (800) 457-7777

Calling from outside the United States (949) 859-4273

Please fill in for your reference and future use:

Model name _____

Model number _____

Serial number _____

Contents

Setting up your computer and getting started.....	4
Your computer's TFT display	13
Inserting a PC Card	13
Removing a PC Card	14
Using SD cards	14
Learning the basics	15
Playing a CD or DVD	16
Moving the computer	19
Mobile computing	19
Important information on your Satellite® computer's cooling fan	24
If something goes wrong	24
If you need further assistance	27
Power cable connectors	28
Features and specifications	28
Regulatory information	34
Index	54

Welcome to the world of powerful and portable multimedia computers! With your new Toshiba notebook computer, your access to information can accompany you wherever you go.

You will find that the Microsoft® Windows® XP operating system is already installed on your computer. It offers exciting features and easy Internet access.

This guide

This guide offers important information about your computer, including solutions to the most common problems, and features and specifications.

For more detailed information, descriptions of other features and more extensive troubleshooting guidelines, see the electronic user's guide preinstalled on your system. It is also available on the Web at pcsupport.toshiba.com.

Safety icons

This guide contains safety instructions that must be observed in order to avoid potential hazards that could result in personal injuries, damage to your equipment, or loss of data. These safety cautions have been classified according to the seriousness of the risk, and the icons highlight these instructions as follows:



DANGER

Danger indicates a hazardous situation, which will result in death, serious personal injury, or substantial property damage if the safety instruction is ignored.



WARNING

Warning indicates a hazardous situation, which can result in death, serious personal injury, or substantial property damage if the safety instruction is ignored.



CAUTION

Caution indicates a hazardous situation, which will or can cause minor personal injury or property damage if the safety instruction is ignored.

NOTE

Provides you with important but not hazard-related information.

Other icons used

Additional icons highlight other helpful or educational information:



TECHNICAL NOTE: This icon highlights technical information about the computer.



HINT: This icon denotes helpful hints and tips.



DEFINITION: This icon indicates the definition of a term used in the text.

Other documentation

Your computer comes with all or some of the following documentation in addition to this resource guide:

- ❖ Electronic user's guide installed on your system.
- ❖ Guides for other software that may come preinstalled.
- ❖ Microsoft® Windows® XP operating system documentation.
- ❖ For accessory information, visit Toshiba's Web site at toshiba.com.
- ❖ The Recovery Media containing the programs that are preinstalled at the factory and any bundled software. Keep this media in a safe and convenient place.

Setting up your computer and getting started

Strain and stress injuries are becoming more common as people spend more time using their computers. With a little care and proper use of the equipment, you can work comfortably throughout the day.

WARNING

Using the computer keyboard incorrectly can result in discomfort and possible injury. If your hands, wrists, and/or arms bother you while typing, stop using the computer and rest. If the discomfort persists, consult a physician.

For more information, consult books on ergonomics, repetitive-strain injury, and repetitive-stress syndrome.

Placement of the computer

Proper placement of the computer and external devices is important to avoid stress-related injuries. Consider the following when placing your computer.

- ❖ Place the computer on a flat surface at a comfortable height and distance. You should be able to type without twisting your torso or neck, and look at the screen without slouching.
- ❖ If you are using an external monitor, the top of the display should be no higher than eye level.
- ❖ If you use a paper holder, set it at about the same height and distance as the screen.

Seating and posture

When using your computer, maintain good posture with your body relaxed and your weight distributed evenly. Proper seating is a primary factor in reducing work strain.

Precautions

Your notebook computer is designed to provide optimum safety and ease of use, and to withstand the rigors of travel. You should observe certain precautions to further reduce the risk of personal injury or damage to the computer.

▲ CAUTION *Never apply heavy pressure to the computer or subject it to sharp impacts. Excessive pressure or impact can damage computer components or otherwise cause your computer to malfunction.*

▲ CAUTION *Some PC Cards become hot with prolonged use. Overheating of a PC Card can result in errors or instability in its operation.*

Be careful when you remove a PC Card that has been used for lengthy periods of time.

Connecting to a power source

Your computer requires power to operate. Use the power cable and AC adapter to connect the computer to a live electrical outlet, or to charge the computer's battery.

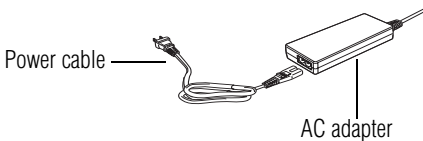

Power Cable and AC adapter

▲ CAUTION *Use only the AC adapter supplied with your computer or an equivalent adapter that is compatible. Use of any incompatible adapter could damage your computer. Toshiba assumes no liability for any damage caused by use of an incompatible adapter.*

When you connect the AC adapter to the computer, always follow the steps in the exact order as described in the User's Manual. Connecting the power cable to a live electrical outlet should be the last step otherwise the adapter DC output plug could hold an electrical charge and cause an electrical shock or minor bodily injury when touched. As a general safety precaution, avoid touching any metal parts.

⚠ DANGER

Hold the power cable by its plug when you connect/disconnect it. Do NOT pull the cable itself. Doing so may damage the power cable and result in a short circuit or electric shock.

⚠ WARNING

The power cord on this product contains lead, a chemical known to the State of California to cause birth defects or other reproductive harm. **Wash hands after handling.**

To connect AC power to the computer:

- 1 Connect the power cable to the AC adapter.
- 2 Plug the AC adapter into the DC-IN on the back of the computer.
- 3 Connect the power cable to a live electrical outlet.

If the electrical outlet is live, the system indicator panel's AC power light (☑) glows green.

⚠ DANGER

Damaged power cables can cause fire or electric shock. Never modify, forcibly bend, place heavy objects on top of, or apply heat to the power cable.

If the power cable becomes damaged or the plug overheats, discontinue use. There is a risk of electric shock.

Never remove the power plug from the outlet with wet hands. Doing so may cause an electric shock.

Connecting a printer

You can connect a USB-compatible printer to your computer through a USB port. You can also connect a parallel printer through the parallel port.

To confirm a printer's compatibility, check its documentation.

Connecting a USB printer

To achieve the connection, you need a suitable USB cable, which may come with your printer. Otherwise, you can purchase one from a computer or electronics store.

NOTE

Follow the manufacturer's instructions for connecting a USB printer to your computer.

Connecting a parallel printer

To achieve the connection, you need a suitable cable, which may come with your parallel printer. Otherwise, you can purchase one from a computer or electronics store.

If you connect a parallel printer, do so before you turn on the computer.

NOTE Follow the manufacturer's instructions for connecting a parallel printer to your computer.

Installing additional memory (optional)

▲ CAUTION Before you install or remove a memory module, turn off the computer using the Start menu. If you install or remove a memory module while the computer is in Standby or Hibernation mode, data will be lost.

A memory module must be installed in slot A. Do not try to operate the computer with a memory module in slot B only.

Your computer is equipped with two memory slots which can provide for various memory configurations. When additional memory is added, or original memory replaced, it is recommended that you use only compatible memory. In the event original memory is replaced with invalid memory, the system will beep and will not start up beyond the BIOS memory check. A message will display. If this occurs, contact Toshiba's support center. See "Toshiba voice contact" on page 27.



HINT: To purchase additional memory modules, visit the Toshiba Web site at toshiba.com.

Your computer comes with enough memory to run most of today's popular applications. You may want to increase the computer's memory if you use complex software or process large amounts of data.

There are two memory slots. Your system may have both slots occupied.

▲ CAUTION If you use the computer for a long time, the memory modules will become hot. If this happens, let the modules cool to room temperature before you replace them.

▲ CAUTION Do not try to install a memory module under the following conditions. You can damage the computer and the module.

1. The computer is turned on.
 2. The computer was shut down using Standby mode.
 3. Power to the DVD-ROM or multi-function drive has been turned on.
-

▲ CAUTION Do not install or remove a memory module while the DVD-ROM or multi-function drive power is on.

You will need a standard Phillips No.1 screwdriver and a small flat head screwdriver to install a memory module.

CAUTION *To avoid damaging the computer's screws, use a standard Phillips screwdriver that is in good condition.*

- 1 If the computer is on, turn it off.
See "Turn Off or Shut down command" in your electronic user's guide.
 - 2 Unplug and remove any cables connected to the computer.
 - 3 Open the display panel and remove the panel above the keyboard that contains the power button.
-

CAUTION *When removing the computer's power button panel to install additional memory, be careful not to damage the display or circuit board.*



Using a flat-head screwdriver to pry off the panel

You can pry the panel out of its position by using a flat-head screwdriver. Starting at the left or right side, carefully wedge the flat-head screwdriver between the panel and the surrounding housing. Grasp the end of the panel and lift up until the panel comes free.

- 4 Remove the three screws that hold the keyboard in place, and remove the keyboard retaining brace.

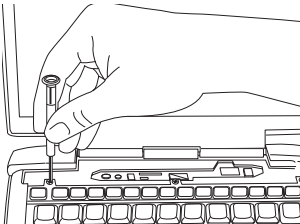

Removing the left keyboard screw

The two-inch-long, propeller-shaped brace sits in the center of the area exposed when the panel is removed.

- NOTE** *Observe how the propeller-shaped keyboard retaining brace is positioned before you remove it.*
Store the brace with the screws for safekeeping.
-

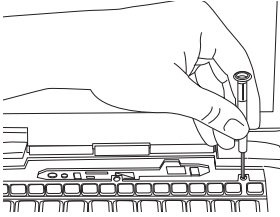

Removing the right keyboard screw

- 5 Lift the keyboard and gently place it face down on the palm rest of the computer.

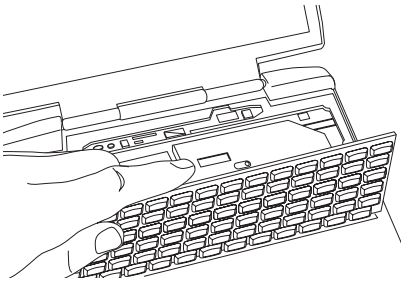

Lifting the keyboard

Removing the keyboard exposes the two memory slots, which are covered by a plastic sheet.

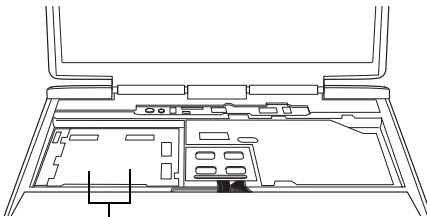

Covered memory slots

Locating the covered memory module slots

- 6 Lift (but do not detach) the plastic sheet to expose the memory slots.

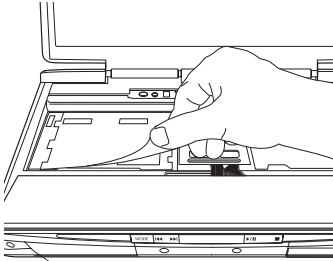

Lifting the plastic covering the memory slots

- 7 Remove the new memory module from its antistatic packaging.

CAUTION *Static electricity can damage the memory module. Before you handle the module, touch a grounded metal surface to discharge any static electricity you may have built up.*

To avoid damaging the memory module, be careful not to touch its pin connector (on the side you insert into the computer).

CAUTION *Avoid touching the connectors on the memory module or on the computer. Grease or dust on the connectors may cause memory access problems.*

- 8 Insert the memory module in a slot and gently press it down into place.

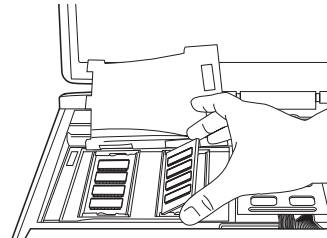

Inserting the memory module

The clips on either side of the module will click to secure the module.

- 9 Cover the slots with the plastic sheet.
- 10 Replace the keyboard.

To secure the keyboard, fit the tabs at the bottom of the keyboard into the corresponding slots at the top of the computer's palm rest.

- 11 Fasten the keyboard with the keyboard retaining brace and screws.

- 12 Replace the panel above the keyboard by doing the following:
 - ❖ Fit the tabs at the bottom of the panel into corresponding slots at the top of the keyboard.
 - ❖ Fit the tabs at the top of the panel into corresponding slots at the base of the display and gently push down.

When the panel is properly positioned, it will snap down into place.

- 13 Reconnect any cables you removed.
- 14 Turn on the computer.

To verify that the computer correctly recognizes the memory, see “Checking total memory” on page 12.

- 15 If the computer does not recognize the memory, shut down the computer, remove the memory slot cover, and make sure the memory module is seated properly, as described in step 8.

Removing a memory module

▲ CAUTION *If you use the computer for a long time, the memory modules will become hot. If this happens, let the modules cool to room temperature before you replace them.*

▲ CAUTION *Do not try to remove a memory module with the computer turned on. You can damage the computer and the device.*

Do not remove the memory module while the computer is in Standby mode. The computer could hang up the next time you turn it on and data in memory will be lost. In either of the above cases, the Standby configuration will not be saved.

The following message appears when you turn on the power:

Warning: Resume Failure
Press Any Key To Continue

If the computer hangs up when you turn it on, perform the following: Press the power button and hold it down for five seconds, then turn the power on again.

- 1 Follow steps 1 through 6 in “Installing additional memory (optional)” on page 7.
- 2 Pull the clips away from the memory module.

The memory module pops partially out of the slot.

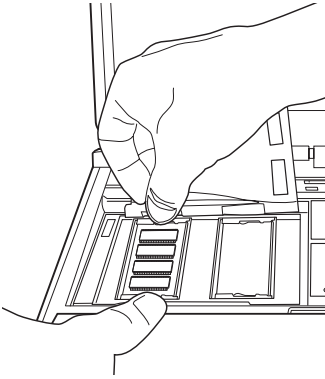

Pulling the clips away from the memory module

- 3 Carefully remove the module from the slot.

CAUTION *Static electricity can damage the memory module. Before you handle the module, touch a grounded metal surface to discharge any static electricity you may have built up.*

To avoid damaging the memory module, be careful not to touch its pin connector (on the side you insert into the computer).

CAUTION *Avoid touching the connectors on the memory module or on the computer. Grease or dust on the connectors may cause memory access problems.*

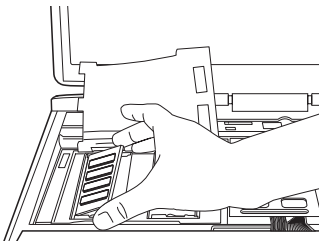

Removing the memory module

- 4 Complete the procedure by following steps 9 through 14 in “Installing additional memory (optional)” on page 7.

Checking total memory

When you add or remove memory, you can check that the computer has recognized the change. To do this:

- 1 Click **Start, Control Panel**.
- 2 Click **Performance and Maintenance**.

- 3 Click **System**.
- 4 The **General** tab view automatically appears and shows the recognized memory.
- 5 If the computer does not recognize the memory, turn off the computer, remove the memory slot cover, and make sure the memory module is seated properly, as described in “Installing additional memory (optional)” on page 7.

Your computer's TFT display

Small bright dots may appear on your TFT display when you turn on your computer. Your display contains an extremely large number of thin-film transistors (TFT) and is manufactured using high-precision technology. Any small bright dots that may appear on your display are an intrinsic characteristic of the TFT manufacturing technology.

Inserting a PC Card

NOTE

Use caution when lifting or turning your computer. Failure to do so may result in damage to components, such as cables, attached to your computer, or to the computer itself.

Before you insert a PC Card, refer to the documentation that comes with the card to see if you need to do anything before you insert it.

- 1 If your PC Card does not support hot swapping, save your data and turn off the computer before inserting the PC Card. For more information, see “Hot swapping a PC Card” on page 14.
- 2 Hold the PC Card with the arrow or main label side up and the connector side toward the PC Card slot.
- 3 Align the card connectors with the PC Card slot and carefully slide the card into the slot until it locks into place.

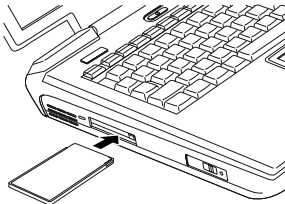

Inserting a PC Card

▲ CAUTION

To avoid damaging the PC Card or the computer, do not force the card into the PC Card slot.

Removing a PC Card

- 1 Click the **Safely Remove Hardware** icon on the System tray.
- 2 Click **Safely remove xxxx**, where *xxxx* is the identifier for your PC Card.

The operating system advises you that you may safely remove the Card.
- 3 Press the PC Card eject button next to the PC Card slot to extend the button.

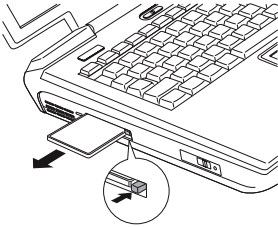

Ejecting the PC Card

- 4 Press the extended eject button so the PC Card pops out slightly.
- 5 Remove the PC Card and store it properly.

Hot swapping a PC Card

One of the great things about PC Cards is that you can replace one PC Card with another while the computer is on. This is called “hot swapping.”

Hot swapping precautions

Although you can insert a PC Card at any time, to avoid data loss never remove a card while it is in use. For example:

- ❖ Never remove an ATA card while the system is accessing it.
- ❖ Never remove a network card while you are connected to a network.
- ❖ Never remove a SCSI card while any of the SCSI devices connected to it are operating.

Before removing a PC Card, shut it down properly. See “Removing a PC Card” on page 14.

Using SD cards

Your computer supports the use of SD (Secure Digital) memory/input/output cards. The cards can be used with a variety of digital products: digital music players, cellular phones, PDAs, digital cameras, digital video camcorders, etc.

Inserting an SD card

NOTE MMC cards (multimedia cards) do not work in this slot.

- 1 Turn the card so that the metal contacts are face down.
- 2 Push the card into the slot until it locks in place.

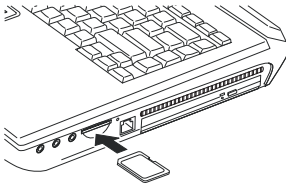

Inserting an SD card

Removing an SD card

- 1 Click the **Safely Remove Hardware** icon on the System tray.
- 2 Click **Safely remove xxxx**, where *xxxx* is the identifier for your SD card.
- 3 Press the card inward to release it.
The card pops out slightly.
- 4 Lift the side of the computer where the card is located, grasp the card, and pull it straight out.

Learning the basics

Computing tips

- ❖ Save your work frequently.

Your work stays in the computer's temporary memory until you save it to the disk. You will lose all unsaved work, if, for example, a system error occurs and you must restart your computer, or your battery runs out of charge while you are working. Your computer can be configured to warn you when the battery is running low.



HINT: Some programs have an automatic save feature that you can turn on. This feature saves your file to the hard disk at preset intervals. See your software documentation for details.

- ❖ Back up your files to diskettes (or other removable storage media) on a regular basis. Label the backup copies clearly and store them in a safe place.

- ❖ Scan all new files for viruses.
 - ❖ Never turn off the computer if a drive indicator light indicates a drive is active.
-

NOTE

The Windows® XP operating system records information, such as your desktop setup, during its shutdown procedure. If you do not let the operating system shut down normally, details such as new icon positions may be lost.

Using the TouchPad™

The TouchPad, the touch-sensitive cutout in front of the keyboard, enables you to move the cursor by brushing your finger on the surface in the direction you want the cursor to move. To move the cursor to the top of the screen, move your finger on the TouchPad away from you. To move the cursor to the bottom, do the opposite.

For more information on the TouchPad, see the electronic user's guide.

Primary and secondary control buttons

When you want to click or choose an item, use the TouchPad to move the pointer/cursor to the item. Once the pointer/cursor is positioned, you can click it into place by either double-tapping the TouchPad or clicking the control buttons.

The control buttons are adjacent to the TouchPad and are used like the buttons on a mouse. The primary control button is the left one and corresponds to the left mouse button. To double-click, press the primary button twice in rapid succession.

The function of the secondary button depends on the program you are using. It usually corresponds to the right mouse button. Check your program's documentation to find whether it uses the secondary mouse button.

Playing a CD or DVD

Optical storage has become the preferred medium for software, music, and video. Digital versatile discs (DVDs) provide a significant increase in data storage and support features that are not available on any other video platform. These features include wide-screen movies, multiple language tracks, digital surround sound, multiple camera angles, and interactive menus.

For these reasons, your computer may come with a DVD-ROM or multi-function drive.



HINT: Your DVD-ROM or multi-function drive is designed to play region 1 (North America) DVD-ROMs.

NOTE *For optimum DVD performance, it is recommended that you play DVDs while running the computer on AC power.*

Drive components and control buttons

The DVD-ROM or multi-function drive is located on the side of the computer. The CD/DVD control buttons are located at the front edge of the computer and can be accessed when the display panel is closed or open.

Components

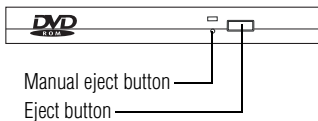

Sample DVD-ROM or multi-function drive shown

Use the eject button to release the disc tray. This button requires power to operate.

▲ CAUTION *Never press the eject button or turn off the computer while the disk/disc activity light is flashing. Doing so could damage the disc or the drive.*

The manual eject button allows you to manually open the disc tray when power to the computer and the drive is off.

▲ CAUTION *Never use a pencil to press the manual eject button. Pencil lead can break off inside the computer and damage it. Instead, use a slim object such as a straightened paper clip.*

Inserting a disc

▲ WARNING *Before playing an audio CD or a DVD, turn down the volume. Playing the disc at maximum volume could damage your ears. To turn down the volume, use the volume control dial or access the Volume Control program (click **Start, All Programs, Accessories, Entertainment, Volume Control**).*

- 1 If the computer is turned on, press the eject button on the DVD-ROM or multi-function drive.

The disc tray partially opens.

▲ CAUTION *To avoid damaging a disc or losing data, check that the Disk/disc activity light is off before opening the disc tray.*

- 2 Grasp the disc tray and pull it fully open.
- 3 Hold the disc by its edges and check that it is clean and free of dust.

CAUTION Handle discs carefully. Avoid touching the surface of the disc. Grasp it by its center hole and edge. If you handle the disc incorrectly, you could lose data.

- 4 Carefully place the disc in the empty tray with its label facing up.

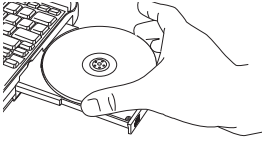

Inserting a disc

CAUTION Be careful not to touch the drive's lens (located underneath the drive's spindle) or the area around it. Doing so could cause the drive to malfunction.

- 5 Gently press the center of the disc onto the spindle until it locks.

CAUTION Make sure the disc is properly positioned on the spindle. If you position the disc incorrectly, it can jam the disc tray.

- 6 Close the disc tray by pressing gently on the center of the tray until it clicks, indicating that it is locked.

Removing a disc with the computer on

CAUTION Never press the eject button while the computer is accessing the drive. Wait for the disk/disc activity light on the system indicator panel to turn off before opening the disc tray.

- 1 Locate and press the eject button.
The disc tray partially opens.
- 2 Grasp the sides of the disc tray and pull it fully open.
- 3 Remove the disc from the disc tray and place it in its protective cover.

CAUTION If the disc is spinning when you open the disc tray, wait for the disc to stop before removing it.

- 4 Close the disc tray by pressing gently on the center of the tray until it clicks indicating that it is locked.

Removing a disc with the computer off

- 1 Insert a slender object, such as a straightened paper clip, into the manual eject button access hole.

▲ CAUTION *Never use a pencil to press the manual eject button. Pencil lead can break off inside the computer and damage it.*

- 2 Pull the tray fully open, remove the disc and place it in its protective cover.
- 3 Close the disc tray by pressing gently on the center of the tray until it clicks indicating it is locked.

Moving the computer

Before moving your computer, even across the room, make sure all disk activity has ended (the drive-in-use lights stop flashing) and all external peripheral cables are disconnected.

▲ CAUTION *Never pick up the computer by its display panel or by the back (where the ports are located).*

Mobile computing

Running the computer on battery power



The computer contains a removable lithium ion (Li-ion) high-capacity battery that provides power when you are away from an AC outlet. You can recharge it many times.

To ensure that the battery maintains its maximum capacity, operate the computer on battery power at least once a month until the battery is fully discharged. Please see “Maximizing battery life” on page 23 for procedures. If the computer is continuously operated on AC power, either through an AC adapter or a docking station for an extended period (more than a month), the battery may fail to retain a charge. It may not function efficiently over the expected life of the battery and the battery light may not indicate a low-battery condition.

Monitoring battery power



The battery light indicates the main battery’s current charge. It:

- ❖ Glows green when the battery is fully charged
- ❖ Glows amber while the battery is being charged

-
- ❖ Does not glow if the external power source is disconnected or if the battery is completely discharged
-



TECHNICAL NOTE: The computer drains the battery faster at low temperatures. Check your remaining charge frequently if you are working in temperatures below 50 degrees Fahrenheit.

The computer calculates the remaining battery charge based on your current rate of power use and other factors such as the age of the battery.

Setting battery alarms

Your computer can be configured to warn you when the battery is running low. For more information, see “Setting battery alarms” in the electronic user’s guide.

Changing the main battery

When your battery power is running low, you have two options: connect the computer to an AC power source or install a charged battery.

NOTE

If your battery discharges fully, your information will be lost. Be sure to save your work often.

▲CAUTION

When handling a battery, be careful not to drop it or short-circuit its terminals. Also, do not drop, hit or otherwise impact the battery. Do not scratch or break the casing and do not twist or bend the battery.

Do not remove the battery while the computer is in Standby mode. Data in memory will be lost.

Removing the battery from the computer

- 1 Save your work.
- 2 Turn off the computer via the **Start** menu.
See “Using Turn Off or Shut down” in your electronic user’s guide.
- 3 Remove all cables connected to the computer.
- 4 Close the display panel and turn the computer upside down.
- 5 Move the battery lock lever toward the front of the computer in order to move the battery release latch.

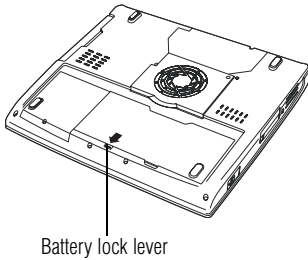

Moving the battery lock lever

- 6 Slide the battery release latch to free the battery, then firmly pull the battery toward yourself.

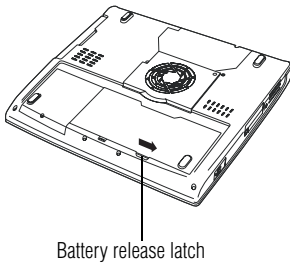

Sliding the battery release latch

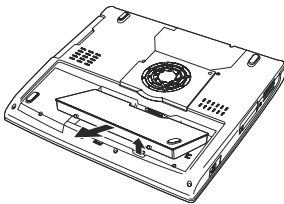

Removing the battery

▲WARNING

If the battery is leaking or its case is cracked, put on protective gloves to handle it, and discard it immediately following the advice in "Disposing of used batteries safely" in the electronic user's guide.

▲CAUTION

For environmental reasons, do not throw away a spent battery. Please return spent batteries to your Toshiba dealer.

Inserting a charged battery

- 1 Turn off the computer via the **Start** menu.
See “Using Turn Off or Shut down” in your electronic user’s guide.
- 2 Remove all cables connected to the computer.
- 3 Close the display panel and turn the computer upside down.
- 4 Insert the battery until it is level with the rest of the computer’s underside

When the battery is properly secured, the battery release latch snaps shut.
- 5 Move the battery lock lever toward the back of the computer to secure the battery release latch.

CAUTION *Failure to lock the battery cover can result in the battery falling out of the computer case.*

- 6 Turn the computer right side up.
- 7 Reconnect any cables you removed.
- 8 Turn on the computer.

Battery safety precautions

- ❖ If the battery pack produces an odor, overheats or changes color or shape while it is being used or charged, turn off the computer’s power immediately and disconnect the power cord from the power socket. Carefully remove the battery pack from the computer.
- ❖ Do not try to disassemble a battery pack.
- ❖ Do not overcharge or reverse charge a battery. Overcharging will shorten its life, and reverse charging could damage it.
- ❖ Avoid touching the metal terminals of the battery with another metal object. Short-circuiting the battery can cause it to overheat and may cause damage to the battery or the computer.
- ❖ Do not incinerate a spent battery, as this could cause it to explode and release toxic materials.
- ❖ If a battery is leaking or damaged, replace it immediately. Use protective gloves when handling a damaged battery.
- ❖ To replace the main battery, use an identical battery that you can purchase through toshiba.com.
- ❖ A reverse polarity condition should be avoided with all batteries. The main battery is designed so that it cannot be installed to cause reverse polarity.
- ❖ Charge the battery only in the computer or in a battery charger designated as an approved option.

- ❖ When you install the battery, you should hear a click when it is seated properly.
- ❖ Do not expose the battery to fire. The battery could explode.

Maximizing battery life

A main battery can be recharged many times. Battery life and charge time vary depending on the applications, power management settings and features used. To maximize the life of your battery:

- ❖ At least once a month, disconnect the computer from a power source and operate it on battery power until the battery fully discharges. Before doing so, follow the steps below:
 - 1 Turn off the computer's power.
 - 2 Disconnect the AC adapter and turn on the computer's power. If it does not turn on, go to step 4.
 - 3 Operate the computer on battery power for five minutes. If the battery has at least five minutes of operating time, continue operating until the battery is fully discharged. If the battery light flashes or there is some other warning to indicate a low battery, go to step 4.
 - 4 Connect the AC adapter to the computer and the power cable to a power outlet. The DC-IN (if applicable to your system) or AC power light should glow green, and the battery light should glow amber to indicate that the battery is being charged. If the DC-IN or AC power light indicator does not glow, power is not being supplied. Check the connections to the AC adapter and power cable.
 - 5 Charge the battery until the battery light glows green.
- ❖ If you have extra batteries, rotate their use.
- ❖ If you will not be using the system for an extended period (more than one month), remove the battery.
- ❖ Disconnect the AC adapter when the battery is fully charged. Overcharging makes the battery hot and shortens life.
- ❖ If you are not going to use the computer for more than eight hours, disconnect the AC adapter.
- ❖ Store spare batteries in a cool dry place out of direct sunlight.

Important information on your Satellite® computer's cooling fan

The CPU cooling fan on the underside of your Satellite computer cools the CPU by drawing outside air into the computer.

CAUTION *To prevent possible overheating of the CPU, make sure the cooling fan's air intake is not blocked. The fan draws in air by creating a vacuum. If the fan is blocked, it could cause the CPU to run at a lower performance level or cause the computer to shut down. Loose items such as notebook and tissue paper, plastic wrappers, or other similar materials can block the air intake, preventing air from reaching the CPU. Do not use the computer on surfaces with objects that can be drawn in by the cooling fan.*

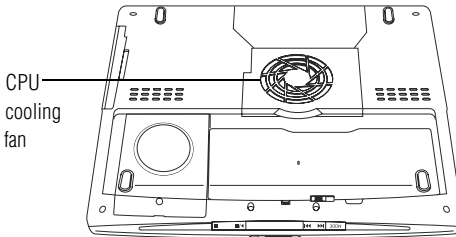

Underside of your Satellite computer

If something goes wrong

Problems that are easy to fix

Your program stops responding.

If you are working with a program that suddenly freezes all operations, chances are the program has stopped responding. You can exit the failed program without shutting down the operating system or closing other programs.

To close a program that has stopped responding:

- 1 Press **Ctrl**, **Alt**, and **Del** simultaneously (once).
- 2 Click the **Applications** tab.

If a program has stopped responding, the words “not responding” appear beside its name in the list.

- 3 Select the program you want to close, then click **End Task**.

Closing the failed program should allow you to continue working. If it does not, continue with step 4.

- 4 Close the remaining programs one by one by selecting the program name, then **End Task**.

- 5 Turn off your computer according to the instructions in “Turn Off or Shut down command” in your electronic user’s guide.

Your program performs an illegal operation.

If you receive the message, “Your program has performed an illegal operation,” you should record the details of the message and consult the software manufacturer.

To record the details, click the **Details** button and copy the text the operating system displays. The Details button displays information that the software manufacturer needs to help you solve your problem.

Problems when you turn on the computer

These problems may occur when you turn on the power.

The computer will not start.

Make sure you attached the AC adapter and power cable properly or installed a charged battery.

Press and hold down the power button until the on/off light changes to green.

If you are using the AC adapter, check that the wall outlet is working by plugging in another device, such as a lamp.

The computer starts but, when you press a key, nothing happens.

You probably have a software or resource conflict. To clear the condition, press Ctrl, Alt and Del simultaneously, then select **Shutdown** and **Restart**. Clearing the condition may get the computer running, but it will not solve a resource conflict. Read the documentation that came with the conflicting device and “Resolving a hardware conflict” in the electronic user’s guide.

The keyboard produces unexpected characters.

A keypad overlay may be on. If the numeric keypad or cursor control light is on, press Fn and F10 simultaneously to turn off the cursor control light or press Fn and F11 simultaneously to turn off the numeric keypad light.

If the problem occurs when both the keypad overlays are off, make sure the software you are using is not remapping the keyboard. Refer to the software’s documentation and check that the program does not assign different meanings to any of the keys.

Display problems

The display is blank.

Display Auto Off may be in effect. Press any key to activate the screen.

You may have activated the instant password feature by pressing Fn and F1 simultaneously.

If you have registered a password, press the Enter key, type the password and press Enter. If no password is registered, press Enter. The screen reactivates and allows you to continue working.

If you are using the built-in screen, make sure the display priority is not set for an external monitor. To do this, hold down Fn and continue to press F5 until the display priority is not the external monitor.

Small bright dots appear on your TFT display when you turn on your computer.

Your display contains an extremely large number of thin-film transistors (TFT) and is manufactured using high-precision technology. The small bright dots that appear on your display are an intrinsic characteristic of the TFT manufacturing technology.

PC Card problems

PC Card checklist

- ❖ Make sure the card is inserted properly into the slot.
See “Using a PC Card” in the electronic user’s guide.
- ❖ Make sure all cables are securely connected.
- ❖ Occasionally a defective PC Card slips through quality control. If another PCMCIA-equipped computer is available, try the card in that machine. If the card malfunctions again, it may be defective.

Here are some common problems and their solutions:

Resolving PC Card problems

The slot appears dead and cards that worked no longer do.

Check the PC Card status:

- 1 Click **Start**.
- 2 Click **My Computer** icon with the secondary button, then click **Properties**.
The System Properties window appears.
- 3 Click the **Hardware** tab.
- 4 Click the **Device Manager** button.
- 5 Double-click the appropriate category for the PC Card being used.
- 6 Double-click the name of the PC Card device.

The operating system displays your PC Card’s Properties window, which contains information about your PC Card configuration and status.

The computer stops working (hangs) when you insert a PC Card.

Remove the PC Card. If removing the PC Card does not resolve the problem, try restarting the computer. If the computer still does not work, contact the PC Card’s manufacturer.

If you need further assistance

If you have followed the recommendations in this chapter and are still having problems, you may need additional technical assistance. This section contains the steps to take to ask for help.

Before you call

Since some problems may be related to the operating system or the program you are using, it is important to investigate other sources of assistance first.

Try the following before contacting Toshiba:

- ❖ Review the troubleshooting information in your operating system documentation.
- ❖ If the problem occurs while you are running a program, consult the program's documentation for troubleshooting suggestions. Contact the software company's technical support group for their assistance.
- ❖ Consult the dealer from whom you purchased your computer and/or program. Your dealer is your best source for current information.

Detailed system specifications are available at www.ts.toshiba.com by selecting your particular product and model number, clicking **GO**, and then clicking the **Detailed Specs** link from the menu on the left. Or just refer to the computer documentation shipped with your product.

For the number of a Toshiba dealer near you, see "Toshiba voice contact" on page 27.

Contacting Toshiba

If you still need help and suspect that the problem is hardware-related, Toshiba offers a variety of resources to help you.

Start with accessing Toshiba on the Internet using any Internet browser by typing pcsupport.toshiba.com.

Toshiba voice contact

Before calling Toshiba, make sure you have:

- ❖ Your computer's model and model number.
- ❖ Your computer's serial number.
- ❖ The computer and any optional devices related to the problem.
- ❖ Backup copies of your operating system and all other preloaded software on diskettes or CD-ROM.
- ❖ Name and version of the program involved in the problem along with its installation diskettes or CD-ROM.
- ❖ Information about what you were doing when the problem occurred.
- ❖ Exact error messages and when they occurred.

For technical support, call the Toshiba InTouch Center:

- ❖ Within the United States at (800) 457-7777
- ❖ Outside the United States at (949) 859-4273

Power cable connectors

Your notebook computer features a universal power supply you can use worldwide. This appendix shows the shapes of the typical AC power cable connectors for various parts of the world.



USA and Canada
(UL and CSA
approved)

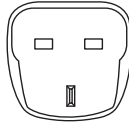

United Kingdom
(BS approved)

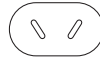

Australia
(AS approved)

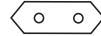

Europe
(VDA and
NEMKO approved)

Features and specifications

This section lists the computer's features.

Technology and processor

Microprocessor	<p>Intel® Pentium® 4 processor 2.53, 2.66, 2.80, 3.06 GHz, 1.475, 1.500, 1.525 V/core</p> <p>CPU performance in your computer product may vary from specifications under the following conditions:</p> <ul style="list-style-type: none"> - use of certain external peripheral products - use of battery power instead of AC power - use of certain multimedia games or videos with special effects - use of standard telephone lines or low speed network connections - use of complex modeling software, such as high end computer aided design applications - use of computer in areas with low air pressure (high altitude >1,000 meters or >3,280 feet above sea level)
----------------	--

- use of computer at temperatures outside the range of 5°C to 35°C (41°F to 95°F) or >25°C (77°F) at high altitude (all temperature references are approximate).

CPU performance may also vary from specifications due to design configuration.

Under some conditions, your computer product may automatically shut-down. This is a normal protective feature designed to reduce the risk of lost data or damage to the product when used outside recommended conditions. To avoid risk of lost data, always make backup copies of data by periodically storing it on an external storage medium. For optimum performance, use your computer product only under recommended conditions. Read additional restrictions under “Environmental Conditions” in this document. Contact Toshiba Technical Service and Support for more information.

Processor L1 cache	12 KB write-back level one cache
Processor L2 cache	512 KB on-chip write-back level two cache
Processor system bus	533 MHz PSB provides optimum speed for memory access.
PCI bus	High performance 32-bit PCI system bus supports HDD and PC Card slot
Memory	2.5-volt 64-bit bus, PC2100 DDR SDRAM, delivers high performance, 2 SODIMM memory slots, Memory modules available: 128 MB, 256 MB, 512 MB Maximum capacity 1024 MB
Graphics	Trident CyberALADDiN-P4 64-bit graphics accelerator; BitBLT hardware, Alpha-blending, Direct3D® and OpenGL® support; 32 MB external DDR video memory

Power

Computer	90 watt autosensing external AC power adapter; 100-240 VAC input voltage, 50/60 Hz frequency, 15V output voltage, 6.0 amps maximum current
----------	--

Main battery	<p>Removable, rechargeable lithium ion (Li-Ion) high-capacity battery (8,400 mAh, 10.8V x 12 cell)</p> <p>Battery life is up to 3.0 hours*</p> <p>Battery recharge time is several hours*</p> <p>*Battery life may vary depending on product model, configuration, applications, power management settings and features utilized. Recharge time varies depending on usage. Battery may not charge while computer is consuming full power. After a period of time, the battery will lose its ability to perform at maximum capacity and will need to be replaced. This is normal for all batteries. To purchase a new battery pack, see the accessories information that shipped with your computer or visit the Toshiba Web site at www.accessories.toshiba.com.</p>
--------------	---

These models achieved the battery life times shown using Ziff Davis Media Inc.'s Business Winstone® 2002 BatteryMark™ Version 1.0. These tests were performed without independent verification by the VeriTest testing division of Lionbridge Technologies, Inc. ("VeriTest"). Neither Ziff Davis Media Inc. nor VeriTest makes any representations or warranties as to the results of the tests. Winstone® is a registered trademark and BatteryMark™ is a trademark of Ziff Davis Publishing Holdings Inc. in the U.S. and other countries. Copyright 2002 Ziff Davis Media Inc. All Rights Reserved. A description of the environment under which the tests were performed is available at www.ts.toshiba.com by selecting your particular product, family and model number, clicking GO, and then clicking on the "Detailed Specs" link from the menu on the left.

RTC battery	Li-Ion battery provides power for the internal real-time clock and calendar
-------------	---



TECHNICAL NOTE: The RTC battery does not charge while the computer is turned off even when AC power is attached.

Intelligent power supply	Detects low battery charge and displays the battery charge remaining or time remaining
--------------------------	--

Storage capacity

Hard disk	2.5-inch drive and controller provide non-volatile storage for 30, 40, 60 or 80 GB (GB means 1 billion bytes)
-----------	---

Ports

S-video port	Lets you connect the computer to an external NTSC/PAL video device such as a standard television
Line-in jack	Allows you to connect your computer to an external audio source to play or record sounds
DC-IN	Lets you connect the computer to AC power, using the AC adapter and power cable
Headphone jack	Use the 3.5 mm headphone jack to connect stereo headphones or other audio output devices. Connecting headphones or other devices to this jack automatically disables the internal speakers
Microphone in jack	3.5 mm jack lets you connect an external monaural microphone
RGB (monitor) port	15-pin, analog VGA port lets you connect an external SVGA monitor (color or monochrome)
Modem port	The modem port lets you connect the internal modem directly to a telephone line via an RJ11 connection
USB 2.0 ports	Support USB peripherals
LAN port	The LAN port lets you connect to a LAN via an RJ45 connection
Parallel port	The parallel port lets you connect a parallel printer

Standard hardware

Memory	The system may come with 256 MB up to a maximum of 1024 MB of RAM
Display options	15.0-inch XGA (measured diagonally) active matrix Thin Film Transistor (TFT) color LCD displays up to 16 million colors at 640 x 480 expansion image, 800 x 600 expansion image; 1024 x 768; 1280 x 1024 virtual display, 1600 x 1200 virtual display 15.0-inch SXGA+ (measured diagonally) active matrix Thin Film Transistor (TFT) color LCD displays up to 16 million colors at 640 x 480 expansion image, 800 x 600 expansion image, 1024 x 768 expansion image, 1280 x 1024 expansion image; 1400 x 1050; 1600 x 1200 virtual display

Communication	<p>Integrated V.92 56K* modem</p> <p>For more detailed information regarding your system's V.92 56K modem, visit the Toshiba Web site at toshiba.com.</p> <p>*Due to FCC limitations, speeds of 53 kbps are the maximum permissible rates during downloads. Actual data transmission speeds will vary depending on on-line conditions.</p>
Networking	Integrated Intel 10/100 Base-TX Ethernet LAN adapter with RJ45 port
Keyboard	Enhanced 85-key keyboard includes embedded numeric and cursor control overlays, dedicated cursor control keys, and Windows® special keys
Pointing device	TouchPad provides the function of a mouse or other pointing device
PC Card slot	One PC Card slot lets you install one Type II PC Card Minimum slot thickness: 5 mm
SD card slot	The SD card slot holds an SD card
Sound controller	Software Sound, 16-bit stereo; built-in stereo speakers; full duplex sound, DirectSound®, Direct3D® Sound, DirectMusic®

Optional accessories and devices

This section lists factory-installed options that are only available at the time of order.

Wireless communication	The computer may come with an optional integrated Wi-Fi (802.11b or 802.11a/b) wireless LAN mini PCI communication module providing wireless LAN functions.
------------------------	---

NOTE

To install the Wi-Fi option at a later time, contact your Toshiba Authorized Service Provider.

3.5-inch diskette drive module	External USB drive accommodates 1.44 MB, high-density (2HDD) diskettes
Additional batteries	Use as spare or replacement packs to extend the time you can operate the computer away from a live electrical outlet
Cable	PORT-Noteworthy® Computer Lock cable to deter computer theft

DVD-ROM drive	24x CD-ROM, 8x DVD-ROM Compatibility: CD-ROM, CD-R (read only), CD-RW (read only), DVD-ROM, DVD-R (read only)
DVD-ROM/ CD-RW drive	24x CD-ROM, 24x CD-R, 10x CD-RW, 8x DVD-ROM Compatibility: CD-ROM, CD-R (read/write), CD-RW (read/rewrite), DVD-ROM, DVD-R (read only), DVD-RW (read only), DVD-RAM (read only)
DVD-R/RW drive	16x CD-R, 10x CD-RW, 1x DVD-R, 1x DVD-RW Compatibility: CD-R (read/write), CD-RW (read/rewrite), CD-ROM, DVD-ROM, DVD-R (read/write), DVD-RW (read/write), DVD-RAM (read only)
DVD Multi drive (when available)	16x CD-R, 10x CD-RW, 2x DVD-R, 2x DVD-RAM, 1x DVD-RW Compatibility: CD-R (read/write), CD-RW (read/rewrite), CD-ROM, DVD-ROM, DVD-R (read/write), DVD-RW (read/write), DVD-RAM (read only)
Hard disk drive	2.5-inch drive provides non-volatile storage for 30 GB, 40 GB, 60 GB or 80 GB (GB means 1 billion bytes)

Physical dimensions

This section lists the computer's specifications

Weight	7.9 pounds
Size	<i>width x depth x height</i> 13.4 inches x 11.6 inches x 1.9 inches

Environmental conditions

	<i>Operating</i>	<i>Non-operating</i>
Temperature	5° to 35° C (41° to 95° F)	-20° to 65° C (-4° to 149° F)
Relative humidity	20% to 80% non-condensing	10% to 95% non-condensing
Altitude (relative to sea level)	-60 to 3,000 m (-197 ft. to 9,842 ft.)	-60 to 10,000 m (-197 ft. to 32,808 ft.)
Shock	10G	60G
Vibration	0.50G	1G

Regulatory information

Model: Satellite® A20/A25 Series

ReWritable CD/DVD Drives

The computer system you purchased may include a ReWritable CD and/or DVD drive(s), among the most advanced data storage technologies available. As with any new technology, you must read and follow all set-up and usage instructions in the applicable user guides and/or manuals enclosed. If you fail to do so, this product may not function properly and you may lose data or suffer other damage. **TOSHIBA AMERICA INFORMATION SYSTEMS (“TOSHIBA”), ITS AFFILIATES AND SUPPLIERS DO NOT WARRANT THAT OPERATION OF THE PRODUCT WILL BE UNINTERRUPTED OR ERROR FREE. YOU AGREE THAT TOSHIBA, ITS AFFILIATES AND SUPPLIERS SHALL HAVE NO RESPONSIBILITY FOR DAMAGE TO OR LOSS OF ANY BUSINESS, PROFITS, PROGRAMS, DATA OR REMOVABLE STORAGE MEDIA ARISING OUT OF OR RESULTING FROM THE USE OF THE PRODUCT, EVEN IF ADVISED OF THE POSSIBILITY THEREOF.**

Protection of Stored Data

For your important data, please make periodic back-up copies of all the data stored on the hard disk or other storage devices as a precaution against possible failures, alteration, or loss of the data. **IF YOUR DATA IS ALTERED OR LOST DUE TO ANY TROUBLE, FAILURE OR MALFUNCTION OF THE HARD DISK DRIVE OR OTHER STORAGE DEVICES AND THE DATA CANNOT BE RECOVERED, TOSHIBA SHALL NOT BE LIABLE FOR ANY DAMAGE OR LOSS OF DATA, OR ANY OTHER DAMAGE RESULTING THEREFROM. WHEN COPYING OR TRANSFERRING YOUR DATA, PLEASE BE SURE TO CONFIRM WHETHER THE DATA HAS BEEN SUCCESSFULLY COPIED OR TRANSFERRED. TOSHIBA DISCLAIMS ANY LIABILITY FOR THE FAILURE TO COPY OR TRANSFER THE DATA CORRECTLY.**

Critical Applications

The computer you have purchased is not designed for any “critical applications.” “Critical applications” means life support systems, medical applications, connections to implanted medical devices, commercial transportation, nuclear facilities or systems or any other applications where product failure could lead to injury to persons or loss of life or catastrophic property damage. **ACCORDINGLY, TOSHIBA, ITS AFFILIATES AND SUPPLIERS DISCLAIM ANY AND ALL LIABILITY ARISING OUT OF THE USE OF THE COMPUTER PRODUCTS IN ANY CRITICAL APPLICATIONS. IF YOU USE THE COMPUTER**

PRODUCTS IN A CRITICAL APPLICATION, YOU, AND NOT TOSHIBA, ASSUME FULL RESPONSIBILITY FOR SUCH USE.

FCC Notice

This equipment has been tested and found to comply with the limits for a Class B digital device, pursuant to Part 15 of the FCC rules. These limits are designed to provide reasonable protection against harmful interference in a residential installation.

This equipment generates, uses and can radiate radio frequency energy and, if not installed and used in accordance with the instructions, it may cause harmful interference to radio communications. However, there is no guarantee that interference will not occur in a particular installation. If this equipment does cause harmful interference to radio or television reception, which can be determined by turning the equipment off and on, the user is encouraged to try to correct the interference by one or more of the following measures:

- ❖ Reorient or relocate the receiving antenna.
- ❖ Increase the separation between the equipment and receiver.
- ❖ Connect the equipment to an outlet on a circuit different from that to which the receiver is connected.
- ❖ Consult the dealer or an experienced radio/TV technician for help.

NOTE

Only peripherals complying with the FCC Class B limits may be attached to this equipment. Operation with noncompliant peripherals or peripherals not recommended by Toshiba is likely to result in interference to radio and TV reception. Shielded cables must be used between the external devices and the computer's or expansion unit's serial port, parallel port, monitor port, USB port, PS/2® port, i.LINK® port and microphone jack. Changes or modifications made to this equipment not expressly approved by Toshiba or parties authorized by Toshiba could void the user's authority to operate the equipment.

This device complies with Part 15 of the FCC Rules. Operation is subject to the following two conditions:

- ❖ This device may not cause harmful interference.
- ❖ This device must accept any interference received, including interference that may cause undesired operation.

Contact:

Toshiba America Information Systems, Inc.
9740 Irvine Blvd.
Irvine, CA 92618-1697
(949) 583-3000

Industry Canada Requirement

This Class B digital apparatus complies with Canadian ICES-003.

Cet appareil numérique de la classe B est conforme à la norme NMB-003 du Canada.

FCC Requirements

The following information is pursuant to FCC CFR 47, Part 68 and refers to internal modems.

Installation

When you are ready to install or use the modem, call your local telephone company and give them the following information:

- ❖ The telephone number of the line to which you will connect the modem.
- ❖ The FCC registration number of the modem.
- ❖ The ringer equivalence number (REN) of the modem, which is 0.6B.

The modem connects to the telephone line by means of a standard jack called the USOC RJ11C.

Type of Service

Your modem is designed to be used on standard-device telephone lines. Connection to telephone company-provided coin service (central office implemented systems) is prohibited. Connection to party lines service is subject to State tariffs. If you have any questions about your telephone line, such as how many pieces of equipment you can connect to it, the telephone company will provide this information upon request.

Telephone Company Procedures

The goal of the telephone company is to provide you with the best service it can. In order to do this, it may occasionally be necessary for them to make changes in their equipment, operations or procedures. If these changes might affect your service or the operation of your equipment, the telephone company will give you notice, in writing, to allow you to make any changes necessary to maintain uninterrupted service.

If Problems Arise

If any of your telephone equipment is not operating properly, you should immediately remove it from your telephone line, as it may cause harm to the telephone network. If the telephone company notes a problem, they may temporarily discontinue service. When practical, they will notify you in advance of this disconnection. If advance notice is not feasible, you will be notified as soon as possible. When you are notified, you will be given the opportunity to correct the problem and informed of your right to file a complaint with the FCC. In the event repairs are ever needed on your modem, they should be performed by Toshiba Corporation, Toshiba

America Information Systems, Inc. or an authorized representative of Toshiba.

Disconnection

If you should ever decide to permanently disconnect your modem from its present line, please call the telephone company and let them know of this change.

Fax Branding

The Telephone Consumer Protection Act of 1991 makes it unlawful to use a computer or other electronic device to send any message via a telephone fax machine unless such message clearly contains in a margin at the top or bottom of each transmitted page or on the first page of the transmission, the date and time it is sent and an identification of the business, other entity or individual sending the message and the telephone number of the sending machine or such business, other entity or individual.

In order to program this information into your fax modem, you should complete the setup for your fax software before sending a message.

Instructions for IC CS-03 certified equipment

- 1 **NOTICE:** The Industry Canada label identifies certified equipment. This certification means that the equipment meets certain telecommunications network protective, operational and safety requirements as prescribed in the appropriate Terminal Equipment Technical Requirements document(s). The Department does not guarantee the equipment will operate to the user's satisfaction.

Before installing this equipment, users should ensure that it is permissible to be connected to the facilities of the local telecommunications company. The equipment must also be installed using an acceptable method of connection. The customer should be aware that compliance with the above conditions may not prevent degradation of service in some situations.

Repairs to certified equipment should be coordinated by a representative designated by the supplier. Any repairs or alterations made by the user to this equipment, or equipment malfunctions, may give the telecommunications company cause to request the user to disconnect the equipment.

Users should ensure for their own protection that the electrical ground connections of the power utility, telephone lines and internal metallic water pipe system, if present, are connected together. This precaution may be particularly important in rural areas.

Caution: Users should not attempt to make such connections themselves, but should contact the appropriate electric inspection authority, or electrician, as appropriate.

- 2 The user manual of analog equipment must contain the equipment's Ringer Equivalence Number (REN) and an explanation notice similar to the following:

The Ringer Equivalence Number (REN) of this device can be found on the label affixed to your computer.

NOTICE: The Ringer Equivalence Number (REN) assigned to each terminal device provides an indication of the maximum number of terminals allowed to be connected to a telephone interface. The termination on an interface may consist of any combination of devices subject only to the requirement that the sum of the Ringer Equivalence Numbers of all the devices does not exceed 5.

- 3 The standard connecting arrangement (telephone jack type) for this equipment is jack type(s): USOC RJ11C.

Wireless Interoperability

The TOSHIBA Wireless LAN Mini PCI Card products are designed to be interoperable with any wireless LAN product that is based on Direct Sequence Spread Spectrum (DSSS) radio technology, and is compliant to:

- ❖ The IEEE 802.11 Standard on Wireless LANs (Revision A/B), as defined and approved by the Institute of Electrical and Electronics Engineers.
- ❖ The Wireless Fidelity (WiFi) certification as defined by the WECA Wireless Ethernet Compatibility Alliance.

Caution

Bluetooth™ and Wireless LAN devices operate within the same radio frequency range and may interfere with one another. If you use Bluetooth™ and Wireless LAN devices simultaneously, you may occasionally experience a less than optimal network performance or even lose your network connection.

If you should experience any such problem, immediately turn off either one of your Bluetooth™ or Wireless LAN.

Please contact Toshiba PC product support on web site <http://www.toshiba-europe.com/computers/tnt/bluetooth.htm> in Europe or <http://www.pcsupport.global.toshiba.com> in the United States for more information.

Caution

This device is restricted to indoor use due to its operation in the 5.15 to 5.85 GHz frequency range.

Wireless LAN and your Health

Wireless LAN products, like other radio devices, emit radio frequency electromagnetic energy. The level of energy emitted by Wireless LAN

devices however is far much less than the electromagnetic energy emitted by wireless devices like for example mobile phones.

Because Wireless LAN products operate within the guidelines found in radio frequency safety standards and recommendations, TOSHIBA believes Wireless LAN is safe for use by consumers. These standards and recommendations reflect the consensus of the scientific community and result from deliberations of panels and committees of scientists who continually review and interpret the extensive research literature.

In some situations or environments, the use of Wireless LAN may be restricted by the proprietor of the building or responsible representatives of the organization. These situations may for example include:

- ❖ Using the Wireless LAN equipment on board of airplanes, or
- ❖ In any other environment where the risk of interference to other devices or services is perceived or identified as harmful.

If you are uncertain of the policy that applies on the use of wireless devices in a specific organization or environment (e.g. airports), you are encouraged to ask for authorization to use the Wireless LAN device prior to turning on the equipment.

Regulatory Information

The TOSHIBA Wireless LAN Mini PCI Card must be installed and used in strict accordance with the manufacturer's instructions as described in the user documentation that comes with the product. This device complies with the following radio frequency and safety standards.

Canada – Industry Canada (IC)

This device complies with RSS 210 of Industry Canada.

The installer of this radio equipment must ensure that the antenna is located or pointed such that it does not emit RF field in excess of Health Canada limits for the general population; consult Safety Code 6, obtainable from Health Canada's website www.hc-sc.gc.ca/rpb. The RF device shall not be co-located with any other transmitter that has not been tested with this device.

Operation is subject to the following two conditions: (1) this device may not cause interference, and (2) this device must accept any interference, including interference that may cause undesired operation of this device.

L'utilisation de ce dispositif est autorisée seulement aux conditions suivantes: (1) il ne doit pas produire de brouillage et (2) l'utilisateur du dispositif doit être prêt à accepter tout brouillage radioélectrique reçu, même si ce brouillage est susceptible de compromettre le fonctionnement du dispositif.

The term "IC" before the equipment certification number only signifies that the Industry Canada technical specifications were met.

To prevent radio interference to the licensed service, this device is intended to be operated indoors and away from windows to provide maximum

shielding. Equipment (or its transmit antenna) that is installed outdoors is subject to licensing.

Pour empêcher que cet appareil cause du brouillage au service faisant l'objet d'une licence, il doit être utilisé à l'intérieur et devrait être placé loin des fenêtres afin de fournir un écran de blindage maximal. Si le matériel (ou son antenne d'émission) est installé à l'extérieur, il doit faire l'objet d'une licence.

Europe – EU Declaration of Conformity

This device complies with the essential requirements of the R&TTE Directive 1999/5/EC with essential test suites as per standards:

- ❖ EN 60950 Safety of Information Technology equipment
- ❖ ETS 300 328 Technical requirements for radio equipment
- ❖ ETS 300 826 General EMC requirements for radio equipment.

België/ Belgique:	<p>For outdoor usage only channel 10 (2457 MHz) and 11 (2462 MHz) is allowed.</p> <p>For private usage outside buildings across public grounds over less than 300m no special registration with IBPT/BIPT is required. Registration to IBPT/BIPT is required for private usage outside buildings across public grounds over more than 300m. An IBPT/BIPT license is required for public usage outside building. For registration and license please contact IBPT/BIPT.</p>
	<p>Gebruik buiten gebouw alleen op kanalen 10 (2457 MHz) en 11 (2462 MHz). Voor privé-gebruik buiten gebouw over publieke grond over afstand kleiner dan 300m geen registratie bij BIPT/IBPT nodig; voor gebruik over afstand groter dan 300m is wel registratie bij BIPT/IBPT nodig. Voor publiek gebruik buiten gebouwen is licentie van BIPT/IBPT verplicht. Voor registratie of licentie kunt u contact opnemen met BIPT.</p>
	<p>L'utilisation en extérieur est autorisée sur le canal 10 (2457 MHz) et 11 (2462 MHz). Dans le cas d'une utilisation privée, à l'extérieur d'un bâtiment, au-dessus d'un espace public, aucun enregistrement n'est nécessaire pour une distance de moins de 300m. Pour une distance supérieure à 300m un enregistrement auprès de l'IBPT est requis. Pour une utilisation publique à l'extérieur de bâtiments, une licence de l'IBPT est requise. Pour les enregistrements et licences, veuillez contacter l'IBPT.</p>
Deutschland:	<p>License required for outdoor installations. Check with reseller for procedure to follow.</p>
	<p>Anmeldung im Outdoor-Bereich notwendig, aber nicht genehmigungspflichtig. Bitte mit Händler die Vorgehensweise abstimmen.</p>

France:	Restricted frequency band: only channels 10 and 11 (2457 MHz and 2462 MHz respectively) may be used in France. License required for every installation, indoor and outdoor installations. Please contact ART for procedure to follow.
	Bande de fréquence restreinte : seuls les canaux 10 à 11 (2457 et 2462 MHz respectivement) doivent être utilisés en France. Toute utilisation, qu'elle soit intérieure ou extérieure, est soumise à autorisation. Vous pouvez contacter l'Autorité de Régulation des Télécommunications (http://www.art-telecom.fr) pour la procédure à suivre.
Italia:	License required for indoor use. Use with outdoor installations not allowed.
	E' necessaria la concessione ministeriale anche per l'uso interno. Verificare con i rivenditori la procedura da seguire. L'uso per installazione in esterni non e' permessa.
Nederland:	License required for outdoor installations. Check with reseller for procedure to follow.
	Licentie verplicht voor gebruik met buitenantennes. Neem contact op met verkoper voor juiste procedure.

USA-Federal Communications Commission (FCC)

This device complies with Part 15 of FCC Rules. Operation of the devices in a Wireless LAN System is subject to the following two conditions:

- ❖ This device may not cause harmful interference.
- ❖ This device must accept any interference that may cause undesired operation.

TOSHIBA is not responsible for any radio or television interference caused by unauthorized modification of the devices included with this TOSHIBA Wireless LAN Mini PCI Card, or the substitution or attachment of connecting cables and equipment other than specified by TOSHIBA.

The correction of interference caused by such unauthorized modification, substitution or attachment will be the responsibility of the user.

Caution: Exposure to Radio Frequency Radiation

The Toshiba Wireless LAN Mini PCI Card will be installed with one of two types of antennas. The both of antenna types, when installed are located at the upper edge of the LCD screen.

For both antennas, the radiated output power of the TOSHIBA Wireless LAN Mini PCI Card is far below the FCC radio frequency exposure limits.

Nevertheless, the TOSHIBA Wireless LAN Mini PCI Card shall be used in such a manner that the potential for human contact during normal operation is minimized. In normal operating configuration, the LCD in the upright position, the distance between the antenna and the user should not be less than 20cm. The antenna(s) used for this transmitter must not be co-located or operating in conjunction with any other antenna or transmitter.

Antenna(s) used in 5.15-5.25GHz frequency band must be integral antenna which provide no access to the end user.

Refer to the Regulatory Statements as identified in the documentation that comes with those products for additional information.

Caution: Radio Frequency Interference Requirements

This device is restricted to indoor use due to its operation in the 5.15 to 5.25 GHz frequency range. FCC requires this product to be used indoors for frequency range 5.15 to 5.25 GHz to reduce the potential for harmful interference to co-channel Mobile Satellite systems.

High power radars are allocated as primary users of the 5.25 to 5.35 GHz and 5.65 to 5.85 GHz bands. These radar stations can cause interference with and/or damage this device.

Taiwan

Article 14 Unless approved, for any model accredited low power radio frequency electric machinery, any company, trader or user shall not change the frequency, increase the power or change the features and functions of the original design.

Article 17 Any use of low power radio frequency electric machinery shall not affect the aviation safety and interfere with legal communications. In event that any interference is found, the use of such electric machinery shall be stopped immediately, and reusing of such products can be resumed until no interference occurs after improvement.

The legal communications mentioned in the above item refer to radio communications operated in accordance with telecommunication laws and regulations.

Low power radio frequency electric machinery shall resist against interference from legal communications or from industrial, scientific and medical radio emission electric machinery.

Using this equipment in Japan

In Japan, the frequency bandwidth of 2,400-2,483.5 MHz for second generation low-power data communication systems such as this equipment overlaps that of mobile object identification systems (premises radio station and specified low-power radio station).

1. Sticker

Please put the following sticker on devices incorporating this product.

In the frequency bandwidth of this equipment, industrial device, scientific device, medical device like microwave oven, licensed premises radio station and non-licensed specified low-power radio station for mobile object identification system (RF-ID) that is used in product line of factories, (Other Radio Stations) are used.

1 Please make sure before using this equipment that no Other Radio Stations are used in the neighborhood.

2 In case that RF interference occurs to Other Radio Stations from this equipment, please change promptly the frequency for use, place to use, or stop emitting Radio.

3 Please contact TOSHIBA Direct PC if you have a problem, such as interference from this equipment to Other Radio Stations

2. Indication

The indication shown below appears on this equipment.

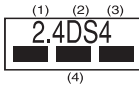

- 1 2.4 this equipment uses a frequency of 2.4 GHz.
- 2 DS. This equipment uses DS-SS modulation.
- 3 The interference range of this equipment is less than 40m.
- 4 This equipment uses a frequency bandwidth from 2,400 MHz to 2,483.5 MHz.

It is possible to avoid the band of mobile object identification systems.

3. TOSHIBA Direct PC

Monday – Friday: 10:00 – 17:00
 Toll Free Tel: 0120-13-1100
 Direct Dial: 03-3457-5916
 Fax: 03-5444-9450

Device Authorization

This device obtains the Technical Regulation Conformity Certification and the Technical Conditions Compliance Approval, and it belongs to the device class of radio equipment of low-power data communication system radio station stipulated in the Radio Law and the Telecommunications Business Law of Japan.

The Name of the radio equipment: MPC13A-20/R

JAPAN APPROVALS INSTITUTE FOR TELECOMMUNICATIONS
 EQUIPMENT

Approval Number: D01-1128JP

TELECOM ENGINEERING CENTER Approval Number: 03NY.A0018, 03GZDA0017

The following restrictions apply:

- ❖ Do not disassemble or modify the device.
- ❖ Do not install the embedded wireless module into other device.

Interference Statement

This equipment has been tested and found to comply with the limits for a Class B digital device, pursuant to Part 15 of the FCC Rules. These limits are designed to provide reasonable protection against harmful interference in a residential installation. This equipment generates, uses, and can radiate radio frequency energy. If not installed and used in accordance with the instructions, it may cause harmful interference to radio communications. However, there is no guarantee that interference will not occur in a particular installation.

If this equipment does cause harmful interference to radio or television reception, which can be determined by turning the equipment off and on, the user is encouraged to try and correct the interference by one or more of the following measures:

- ❖ Reorient or relocate the receiving antenna.
- ❖ Increase the distance between the equipment and the receiver.
- ❖ Connect the equipment to an outlet on a circuit different from that to which the receiver is connected.
- ❖ Consult the dealer or an experienced radio/TV technician for help.

Toshiba is not responsible for any radio or television interference caused by unauthorized modification of the devices included with this Toshiba Wireless LAN Mini PCI Card, or the substitution or attachment of connecting cables and equipment other than specified by Toshiba.

The correction of interference caused by such unauthorized modification, substitution or attachment will be the responsibility of the user.

NOTE

The following information is dependent on what type of wireless device is in your computer.

Approved Countries/Regions for use for the Atheros AR5001X Mini PCI Wireless network adapter

This equipment is approved to the radio standard by the countries/regions in the following table.

CAUTION

Do not use this equipment except in the countries/regions in the following table.

NOTE

This device works on passive scan only.

A peer-to-peer mode is not available in 802.11a and Turbo Mode.

802.11b (2.4GHz)

Australia	Austria	Belgium
Canada	Denmark	Finland
France	Germany	Greece
Ireland	Italy	Liechtenstein
Luxembourg	Netherlands	New Zealand
Norway	Portugal	Sweden
Switzerland	UK	USA

802.11a (5GHz)

Australia	Austria	Belgium
Canada	Denmark	Finland
France	Germany	Greece
Ireland	Italy	Liechtenstein
Luxembourg	Netherlands	New Zealand
Norway	Portugal	Sweden
Switzerland	UK	USA

Turbo Mode (5GHz)

Canada	USA	
--------	-----	--

Approved Countries/Regions for use for the Intel® PRO/Wireless LAN 2100 3B Mini PCI Adapter

This equipment is approved to the radio standard by the countries/regions in the following table.

CAUTION

Do not use this equipment except in the countries/regions in the following table.

Argentina	Australia	Austria
Belgium	Brazil	Canada
Chile	Denmark	Finland
France	Germany	Greece

Iceland	Ireland	Italy
Japan	Liechtenstein	Luxembourg
Mexico	Netherlands	New Zealand
Norway	Peru	Portugal
Singapore	Spain	Sweden
Switzerland	UK	Uruguay
USA	Venezuela	

Approved Countries/Regions for use for the Toshiba Mini PCI Wireless LAN Card

This equipment is approved to the radio standard by the countries/regions in the following table.

CAUTION Do not use this equipment except in the countries/regions in the following table.

Australia	Austria	Belgium
Canada	Denmark	Finland
France	Germany	Greece
Hong Kong	Iceland	Ireland
Italy	Japan	Liechtenstein
Luxembourg	Malaysia	Netherlands
New Zealand	Norway	Philippines
Portugal	Singapore	Spain
Sweden	Switzerland	Thailand
UK	USA	

Bluetooth wireless technology Interoperability

Bluetooth™ Cards from TOSHIBA are designed to be interoperable with any product with Bluetooth wireless technology that is based on Frequency Hopping Spread Spectrum (FHSS) radio technology, and is compliant to:

- ❖ Bluetooth Specification Ver.1.1, as defined and approved by The Bluetooth Special Interest Group.
- ❖ Logo certification with Bluetooth wireless technology as defined by The Bluetooth Special interest Group.

▲ CAUTION *Bluetooth wireless technology is a new innovative technology, and TOSHIBA has not confirmed compatibility of its Bluetooth™ products with all PCs and/or equipment using Bluetooth wireless technology other than TOSHIBA portable computers.*

Always use Bluetooth™ cards from TOSHIBA in order to enable wireless networks over two or more (up to a total of seven) TOSHIBA portable computers using these cards. Please contact TOSHIBA PC product support on Web site <http://www.toshiba-europe.com/computers/tnt/bluetooth.htm> in Europe or <http://www.pcsupport.global.toshiba.com> in the United States for more information.

When you use Bluetooth™ cards from TOSHIBA close to 2.4 GHz Wireless LAN devices, Bluetooth transmissions might slow down or cause errors. If you detect certain interference while you use Bluetooth™ cards from TOSHIBA, always change the frequency, move your PC to the area outside of the interference range of 2.4 GHz Wireless LAN devices (40 meters/43.74 yards or more) or stop transmitting from your PC. Please contact TOSHIBA PC product support on Web site <http://www.toshiba-europe.com/computers/tnt/bluetooth.htm> in Europe or <http://www.pcsupport.global.toshiba.com> in the United States for more information.

Bluetooth™ and Wireless LAN devices operate within the same radio frequency range and may interfere with one another. If you use Bluetooth™ and Wireless LAN devices simultaneously, you may occasionally experience a less than optimal network performance or even lose your network connection. If you should experience any such problem, immediately turn off either one of your Bluetooth™ or Wireless LAN. Please contact Toshiba PC product support on web site <http://www.toshiba-europe.com/computers/tnt/bluetooth.htm> in Europe or <http://www.pcsupport.global.toshiba.com> in the United States for more information.

Bluetooth wireless technology and your Health

The products with Bluetooth wireless technology, like other radio devices, emit radio frequency electromagnetic energy. The level of energy emitted by devices with Bluetooth wireless technology however is far much less than the electromagnetic energy emitted by wireless devices like for example mobile phones.

Because products with Bluetooth wireless technology operate within the guidelines found in radio frequency safety standards and recommendations, TOSHIBA believes Bluetooth wireless technology is safe for use by consumers. These standards and recommendations reflect the consensus of the scientific community and result from deliberations of panels and committees of scientists who continually review and interpret the extensive research literature.

In some situations or environments, the use of Bluetooth wireless technology may be restricted by the proprietor of the building or responsible representatives of the organization. These situations may for example include:

- ❖ Using the equipment with Bluetooth wireless technology on board of airplanes, or

- ❖ In any other environment where the risk of interference to other devices or services is perceived or identified as harmful.

If you are uncertain of the policy that applies on the use of wireless devices in a specific organization or environment (e.g. airports), you are encouraged to ask for authorization to use the device with Bluetooth wireless technology prior to turning on the equipment.

Regulatory statements

This product complies with any mandatory product specification in any country/ region where the product is sold. In addition, the product complies with the following:

Canada-Industry Canada (IC)

This device complies with RSS 210 of Industry Canada.

Operation is subject to the following two conditions: (1) this device may not cause interference, and (2) this device must accept any interference, including interference that may cause undesired operation of this device.”

L' utilisation de ce dispositif est autorisée seulement aux conditions suivantes : (1) il ne doit pas produire de brouillage et (2) l' utilisateur du dispositif doit être prêt à accepter tout brouillage radioélectrique reçu, même si ce brouillage est susceptible de compromettre le fonctionnement du dispositif.

The term "IC" before the equipment certification number only signifies that the Industry Canada technical specifications were met.

Caution: FCC Interference Statement

This device complies with part 15 of the FCC rules. Operation is subject to the following two conditions:

- ❖ This device may not cause harmful interference, and
- ❖ This device must accept any interference received, including interference that may cause undesired operation.

Note that any changes or modifications to this equipment not expressly approved by the manufacturer may void the authorization to operate this equipment.

Caution: Exposure to Radio Frequency Radiation

The radiated output power of the Bluetooth™ Card from TOSHIBA is far below the FCC radio frequency exposure limits. Nevertheless, the Bluetooth™ Card from TOSHIBA shall be used in such a manner that the potential for human contact during normal operation is minimized.

In order to comply with FCC radio-frequency radiation exposure guidelines for an uncontrolled environment, the Bluetooth™ Card from TOSHIBA has to be operated while maintaining a minimum body to antenna which are located on top of LCD distance of 20 cm.

Refer to the Regulatory Statements as identified in the documentation that comes with those products for additional information.

The Bluetooth™ Card from TOSHIBA is far below the FCC radio frequency exposure limits.

Nevertheless, it is advised to use the Bluetooth™ Card from TOSHIBA in such a manner that human contact during normal operation is minimized.

NOTE

Changes or modifications made to this equipment not expressly approved by TOSHIBA or parties authorized by TOSHIBA could void the user's authority to operate the equipment.

Taiwan

Article 14 Unless approved, for any model accredited low power radio frequency electric machinery, any company, trader or user shall not change the frequency, increase the power or change the features and functions of the original design.

Article 17 Any use of low power radio frequency electric machinery shall not affect the aviation safety and interfere with legal communications. In event that any interference is found, the use of such electric machinery shall be stopped immediately, and reusing of such products can be resumed until no interference occurs after improvement.

The legal communications mentioned in the above item refer to radio communications operated in accordance with telecommunication laws and regulations.

Low power radio frequency electric machinery shall resist against interference from legal communications or from industrial, scientific and medical radio emission electric machinery.

Using this equipment in Japan

In Japan, the frequency bandwidth of 2,400-2,483.5 MHz for second generation low-power data communication systems such as this equipment overlaps that of mobile object identification systems (premises radio station and specified low-power radio station).

1. Sticker

Please put the following sticker on devices incorporating this product.

In the frequency bandwidth of this equipment, industrial device, scientific device, medical device like microwave oven, licensed premises radio station and non-licensed specified low-power radio station for mobile object identification system (RF-ID) that is used in product line of factories.(Other Radio Stations) are used.

1 Please make sure before using this equipment that no Other Radio Stations are used in the neighborhood.

2 In case that RF interference occurs to Other Radio Stations from this equipment, please change promptly the frequency for use, place to use, or stop emitting Radio.

3 Please contact TOSHIBA Direct PC if you have a problem, such as interference from this equipment to Other Radio Stations

2. Indication

The indication shown below appears on this equipment.

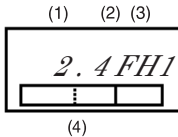

- 1 2.4: this equipment uses a frequency of 2.4 GHz.
- 2 FH: This equipment uses FH-SS modulation.
- 3 The interference range of this equipment is less than 10m.
- 4 This equipment uses a frequency bandwidth from 2,400 MHz to 2,483.5 MHz. It is impossible to avoid the band of mobile object identification systems.

3. TOSHIBA Direct PC

Monday – Friday:	10:00 – 17:00
Toll Free Tel:	0120-13-1100
Direct Dial:	03-3457-5916
Fax:	03-5444-9450

Device Authorization

This device obtains the Technical Regulation Conformity Certification, and it belongs to the device class of radio equipment of low-power data communication system radio station stipulated in the Radio Law of Japan.

The Name of the radio equipment: EYXF2CS

TELECOM ENGINEERING CENTER

Approval Number: 01NYDA1305

The following restrictions apply:

- ❖ Do not disassemble or modify the device.

- ❖ Do not install the embedded wireless module into other device.

CD-ROM, DVD-ROM, Multi-function Drive Safety Instructions

CD-ROM, DVD-ROM and multi-function drives employ a laser system. To ensure proper use of this product, please read this instruction manual carefully and retain for future reference. Should the unit ever require maintenance, contact an authorized service location.

Use of controls, adjustments or the performance of procedures other than those specified may result in hazardous radiation exposure.

To prevent direct exposure to the laser beam, do not try to open the enclosure.

Location of the required label

(Sample shown below. (Location of the label and manufacturing information may vary.)

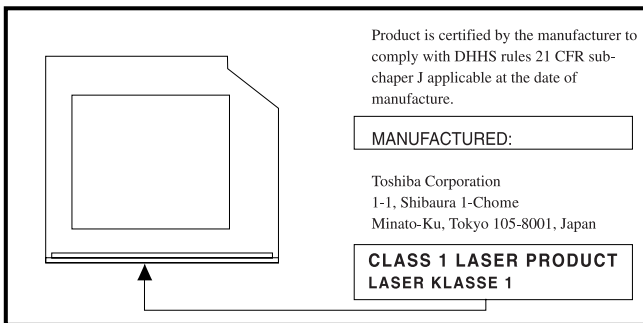

⚠ CAUTION

This appliance contains a laser system and is classified as a "CLASS 1 LASER PRODUCT." To use this model properly, read the instruction manual carefully and keep it for your future reference. In case of any trouble with this model, please contact your nearest "AUTHORIZED service station." To prevent direct exposure to the laser beam, do not try to open the enclosure.

CLASS 1 LASER PRODUCT
LASER KLASSE 1

Use of controls or adjustments or performance of procedures other than those specified in the owner's manual may result in hazardous radiation exposure.

Copyright

This guide is copyrighted by Toshiba America Information Systems, Inc. with all rights reserved. Under the copyright laws, this guide cannot be reproduced in any form without the prior written permission of Toshiba. No patent liability is assumed, however, with respect to the use of the information contained herein.

©2003 by Toshiba America Information Systems, Inc. All rights reserved.

Export Administration Regulation

This document contains technical data that may be controlled under the U.S. Export Administration Regulations, and may be subject to the approval of the U.S. Department of Commerce prior to export. Any export, directly or indirectly, in contravention of the U.S. Export Administration Regulations is prohibited.

Notice

The information contained in this manual, including but not limited to any product specifications, is subject to change without notice.

TOSHIBA CORPORATION AND TOSHIBA AMERICA INFORMATION SYSTEMS, INC. (TOSHIBA) PROVIDES NO WARRANTY WITH REGARD TO THIS MANUAL OR ANY OTHER INFORMATION CONTAINED HEREIN AND HEREBY EXPRESSLY DISCLAIMS ANY IMPLIED WARRANTIES OF MERCHANTABILITY OR FITNESS FOR ANY PARTICULAR PURPOSE WITH REGARD TO ANY OF THE FOREGOING. TOSHIBA ASSUMES NO LIABILITY FOR ANY DAMAGES INCURRED DIRECTLY OR INDIRECTLY FROM ANY TECHNICAL OR TYPOGRAPHICAL ERRORS OR OMISSIONS CONTAINED HEREIN OR FOR DISCREPANCIES BETWEEN THE PRODUCT AND THE MANUAL. IN NO EVENT SHALL TOSHIBA BE LIABLE FOR ANY INCIDENTAL, CONSEQUENTIAL, SPECIAL, OR EXEMPLARY DAMAGES, WHETHER BASED ON TORT, CONTRACT OR OTHERWISE, ARISING OUT OF OR IN CONNECTION WITH THIS MANUAL OR ANY OTHER INFORMATION CONTAINED HEREIN OR THE USE THEREOF.

Trademarks

Satellite, Noteworthy and InTouch are registered trademarks of Toshiba America Information Systems, Inc. and/or Toshiba Corporation.

Microsoft, Direct3D, DirectSound, DirectMusic and Windows are registered trademarks of Microsoft Corporation.

Wi-Fi is a trademark of the Wireless Capability Ethernet Alliance.

Bluetooth is a trademark owned by its proprietor and used by Toshiba under license. TouchPad is a trademark of Synaptics, Inc. Intel and Pentium are registered trademarks of the Intel Corporation. PS/2 is a registered trademark of IBM, Inc. i.LINK is a registered trademark of Sony Corporation. OpenGL is a registered trademark of Silicon Graphics, Inc. BatteryMark is a trademark of Ziff Davis Publishing Holdings Inc.

All other brand and product names are trademarks or registered trademarks of their respective companies.

Computer Disposal Information

This product contains mercury. Disposal of this material may be regulated due to environmental considerations. For disposal, reuse or recycling information, please contact your local government or the Electronic Industries Alliance at www.eiae.org.

Index

A

- AC adapter 5
- AC power light 5
- adding memory 7
- alarms low battery 20
- avoiding injury 4

B

- battery
 - alarms 20
 - changing 20
 - installing 20
 - light 20
 - monitoring power 20
 - removing 20
- built-in features 28
- buttons
 - CD/DVD controls 17
 - control 16
 - DVD-ROM drive
 - eject 17
 - multi-function drive
 - eject 17

C

- card
 - SD 14
- CD/DVD control buttons 17
- CD/DVDs
 - inserting 17, 18
 - removing 18
- CDs
 - inserting 18
- changing
 - main battery 20
- comfort
 - chair 5
- compact discs
 - inserting 18
- computer
 - moving 19
 - placement 4
 - setting up 7
- computing tips 15

- connecting
 - AC adapter 5
 - power cable 6
 - printer 6
- control buttons 16

D

- DC-IN 6
- Digital Versatile Discs (DVDs) 16
- display
 - screen is blank 25
- DVD-ROM drive
 - eject button 17
 - inserting a disc 17
 - removing a disc 18

E

- environmental considerations 4
- ergonomics
 - seating guidelines 5
- error messages
 - program has performed an illegal operation 25

F

- files
 - backing up 15
 - saving 15

H

- help
 - Toshiba Web sites 27
- hot swapping
 - precautions 14

I

- icons
 - safety 3
- inserting
 - CDs and DVDs 18
 - PC Card 13
 - SD card 15
- installing
 - main battery 20
 - memory module 7

interference statement 44
internal drives 32

K

keyboard
unexpected characters 25

L

lights
AC power 5
battery 20

M

main battery
changing 20
removing 20
memory
accessing slots 8
adding 7
removing 11
memory module
removing 12
Microsoft Windows XP 3
moving the computer 19
multi-function drive
eject button 17
inserting a disc 17
removing a disc 18

O

operating system 3
optional devices 32

P

PC Card
checklist 26
computer stops working 26
inserting 13
problem solving 26
removing 14
replacing 14
port
specifications 31
power
cable 6
cable connectors 28
computer will not start 25
monitoring 20
specifications 29
power devices 32
precautions 5

primary control button 16
printer
connecting 6
problem solving
computer hangs when PC Card inserted 26
computer will not power up 25
contacting Toshiba 27
display is blank 25
illegal operation 25
keyboard produces unexpected characters 25
PC Card checklist 26
PC Card slot appears dead 26
program not responding 24
processor, specifications 28

R

removing
disc with computer off 19
disc with computer on 18
main battery 20
PC Card 14

S

safety
icons 3
precautions 5
screen
blank 25
SCSI (Small Computer Systems Interface) 14
SD card
inserting 15
removing 15
using 14
secondary control button 16
setting
battery alarms 20
setting up
AC adapter 5
computer 7
specifications 28
environmental 33
physical dimensions 32, 33
ports 31
power 29
processor 28
standard hardware 31
storage capacity 30
standard hardware, specifications 31
storage capacity, specifications 30

T

- tips on computing 15
- Toshiba Accessories Information 4
- Toshiba Web sites 27
- TouchPad
 - using 16

Free Manuals Download Website

<http://myh66.com>

<http://usermanuals.us>

<http://www.somanuals.com>

<http://www.4manuals.cc>

<http://www.manual-lib.com>

<http://www.404manual.com>

<http://www.luxmanual.com>

<http://aubethermostatmanual.com>

Golf course search by state

<http://golfingnear.com>

Email search by domain

<http://emailbydomain.com>

Auto manuals search

<http://auto.somanuals.com>

TV manuals search

<http://tv.somanuals.com>