

PROGRAMMABLE CONTROLLER
PROSEC T3

ANALOG OUTPUT MODULE
DA364/DA374
USER'S MANUAL

[Contents](#)

Toshiba Corporation

Important information

Misuse of this equipment can result in property damage or human injury. Because controlled system applications vary widely, you should satisfy yourself as to the acceptability of this equipment for your intended purpose.

In no event will Toshiba Corporation be responsible or liable for either indirect or consequential damage or injury that may result from the use of this equipment.

No patent liability is assumed by Toshiba Corporation with respect to the use of information, illustrations, circuits, equipment, or examples of applications in this publication.

Toshiba Corporation reserves the right to make changes and improvements to this publication and/or related products at any time without notice. No obligation shall be incurred, except as noted in this publication.

This publication is protected by copyright and contains proprietary material. No part of this book may be reproduced, stored in a retrieval system, or transmitted in any form or by any means—electrical, mechanical, by photocopying, recording or otherwise—without obtaining prior written permission from Toshiba.

Copyright 1994 by Toshiba Corporation
Tokyo, Japan

Publication number: UM-TS03***E017
1st edition July 1994.

Before reading this manual

Introduction This manual explains the specification and operation of Toshiba's 4-channel voltage output type analog output module DA364 and 4-channel current output type analog output module DA374 for PROSEC T3. Read this manual carefully before using the DA364/DA374 modules.
Besides this manual, read the following manuals and descriptions before operation, if necessary, for your better understanding.

Related manuals The following related manuals are available for the T3.

T3 User's Manual - Hardware

This manual covers the T3's main body and basic I/O - their specifications, handling, maintenance and services.

T3 User's Manual - Functions

This document explains the functions of the T3 and how to use them. The necessary information to create user program is covered in this volume.

T-series Instruction Set

This manual provides the detailed specifications of instructions for Toshiba's T-series Programmable Controllers.

T-PDS Basic Operation Manual

This manual explains how to install the T-series program development system (T-PDS) into your personal computer and provides basic programming operations.

T-PDS Command Reference Manual

This manual explains each command of the T-series program development system (T-PDS) in detail.

T-series Computer Link Function

This manual explains the specification and handling method of the T-series Programmable Controller's Computer Link function.

Precautions

- Use the DA364/DA374 only on the rack of the T3.
- Do not touch the internal components on the DA364/DA374 printed circuit board. It may cause damage to the module.
- Read the precautions of this manual and the T3 manuals before installing and wiring the module.

Before reading this manual

Note and caution symbols

Users of this manual should pay attention to information preceded by the following symbols.



NOTE Calls the reader's attention to information considered important for full understanding of procedures and/or operation of the equipment.



CAUTION Calls the reader's attention to conditions or practices that could damage the equipment or render it temporarily inoperative.

Terminology

The following is a list of abbreviations and acronyms used in this manual.

CPU	Central Processing Unit
EEPROM	Electrically Erasable Programmable Read Only Memory
Hex.	Hexadecimal
I/O	Input/Output
LED	Light Emitting Diode
ms	millisecond
RAM	Random Access Memory
Vac	ac voltage
Vdc	dc voltage

Contents	1. Overview of the DA364/DA374	5
	1.1 Overview	5
	1.2 Names and functions	6
	1.3 Internal block diagram	9
	2. Settings	10
	2.1 Settings for output signal ranges	10
	3. Installing and Wiring	12
	3.1 Installing the module	12
	3.2 Wiring	13
	3.2.1 Terminal arrangement	13
	3.2.2 How to wire	14
	3.3 Application precautions	15
	3.3.1 Installing environment	15
	3.3.2 Wiring precautions	16
	4. Register Configuration	17
	4.1 I/O registers and buffer memory	17
	4.2 Data format	20
	4.2.1 Analog output data	20
	4.2.2 Status	22
	4.2.3 Offset calibration data	23
	4.2.4 Gain calibration data	23
	Appendix	24
	A. Specification	24
	B. Operation flow	25
	C. How to calibrate	26
	D. Details of the READ instruction	28
	E. Details of the WRITE instruction	30

1. Overview of the DA364/DA374

1.1 Overview

Toshiba's 4-channel analog output modules DA364/DA374 will convert digital data processed in the T3 to analog signal. The DA364/DA374 have the following features:

1. 4 channels of analog output per module
 2. 12-bit high resolution per channel
 3. Selectable output ranges (1 range per module)
 4. Gain and offset calibration function for each channel
- The maximum 4 channels of analog signals can be output. 4 words of T3's output register (YW) are assigned to the DA364/DA374.
 - The DA364/DA374 convert the 4 words of digital data into 4 channels of analog signals every 10 ms.
 - The DA364/DA374 need an external power supply (24 Vdc / 200 mA).

The following analog signals can be output by setting the internal jumper plugs and the rotary switch of the DA364/DA374.

DA364

Voltage output	Bipolar	$\pm 5\text{ V}$ $\pm 10\text{ V}$
	Unipolar	0 to 5 V 0 to 10 V 1 to 5 V

DA374

Current output	Unipolar	0 to 20 mA 4 to 20 mA
----------------	----------	--------------------------

1. Overview of the DA364/DA374

1.2 Names and functions

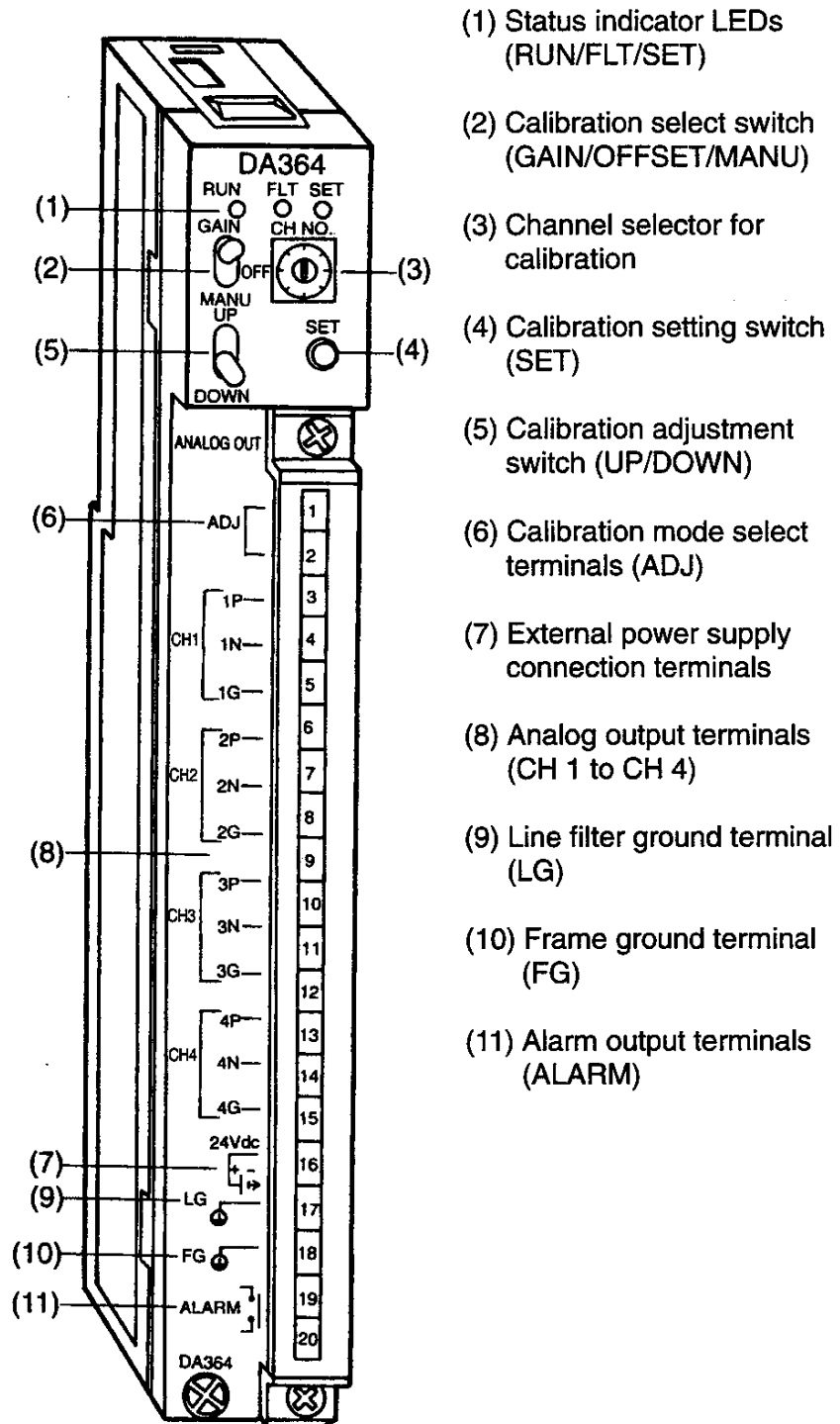

1. Overview of the DA364/DA374

(1) Status indicator LEDs

1) RUN

RUN will be lit in normal state of the module, and will not be lit in abnormal state.

2) FLT

FLT will be lit if an error has occurred in the module.

3) SET

When the calibration setting switch is pressed, SET will be lit during write, and will go out when the write ends.

Name	Lit ●	Not lit ○	Blinking ●
RUN	Normal state	Abnormal state	Calibration mode
FLT	Error occurred External 24 Vdc abnormal	Normal state	—
SET	Calibration data being written	Normal state	—

(2) Calibration select switch (GAIN/OFFSET/MANU)

In calibration mode, setting items can be selected either GAIN or OFFSET by this switch.

Adjust gains with this switch in GAIN position, and adjust offset with this switch in OFFSET position. The MANU position is unused.

Name	Function
GAIN	Gain adjustment
OFFSET	Offset adjustment
MANU	Unused

(3) Channel selector for calibration

This rotary switch changes over channels in calibration.

Numbers 1 to 4 of the rotary switch correspond to CH 1 to CH 4, respectively. Numbers 0, 5 through 9 of the rotary switch are unassigned.

Switch position	Corresponding channel
0	—
1	Channel 1
2	Channel 2
3	Channel 3
4	Channel 4
5	—
6	—
7	—
8	—
9	—

1. Overview of the DA364/DA374

- (4) Calibration setting switch (SET)
Pressing this switch will write the calibration data into the EEPROM built in the DA364/DA374.
- (5) Calibration adjustment switch (UP/DOWN)
Every time when you turn this switch to UP side, the content of the calibration data will be increased by one. When you keep turning the switch for a few seconds, the data will be increased continuously. When you turn this switch to DOWN side, the calibration data will be decreased by one. When you keep turning the switch for a few seconds, the data will be decreased continuously.
- (6) Calibration mode select terminals (ADJ)
When these terminals are shorted, calibration becomes available. Normally, these terminals should be open.
- (7) External power supply connection terminals
External 24 Vdc power will be connected with these terminals. (24 Vdc \pm 10%.)
- (8) Analog output terminals (CH 1 to CH 4)
These terminals will be connected with external analog equipment. For detailed wiring, see Section 3.2.
- (9) Line filter ground terminal (LG)
Normally, this terminal is shorted with the FG terminal. Depending on grounding condition, this terminal will be open, or grounded separately.
- (10) Frame ground terminal (FG)
This terminal has been connected with the T3's FG terminal in the module.
- (11) Alarm output terminals (ALARM)
While FLT is lit (module error), the built-in relay will be opened. While FLT is not lit, the relay will be closed. The maximum load capacity of the relay is 30 Vdc/0.5 A. Use a protective fuse of 1 A externally.

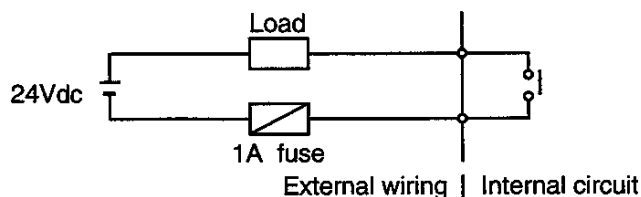

1. Overview of the DA364/DA374

1.3 Internal block diagram

The internal block diagram of the DA368/DA374 is shown below.

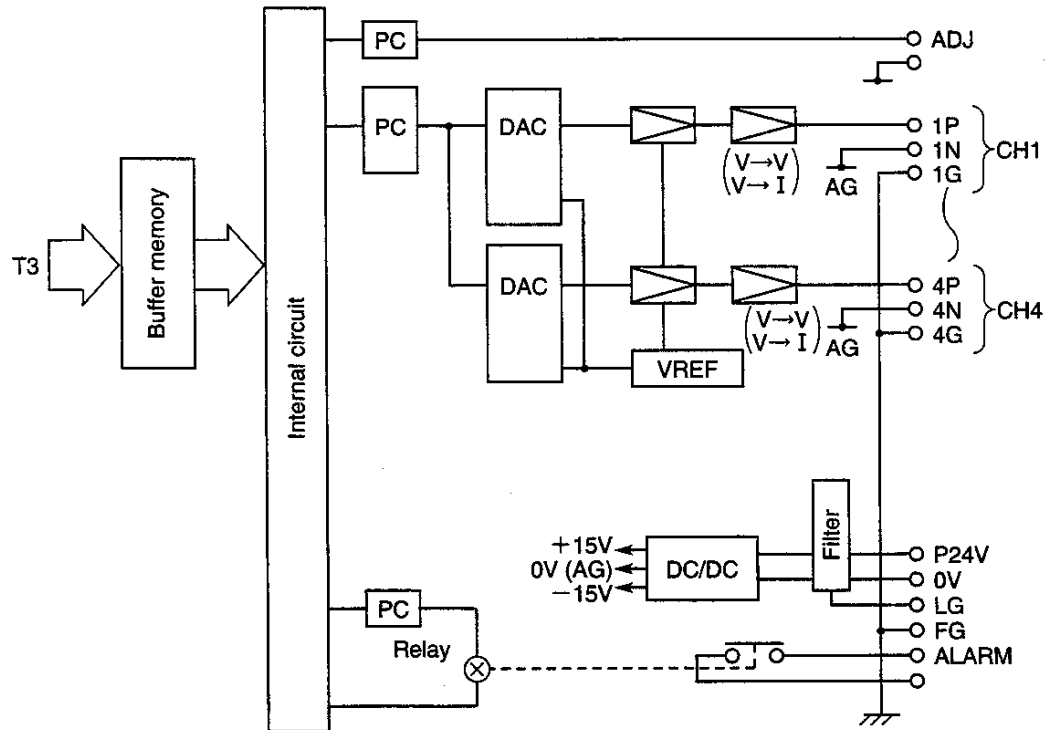

PC: Photo-coupler
 DAC: Digital/analog converter
 VREF: Reference voltage

2. Settings

2.1 Settings for output signal ranges

Set the internal rotary switch and the jumper plugs according to the output analog signal.

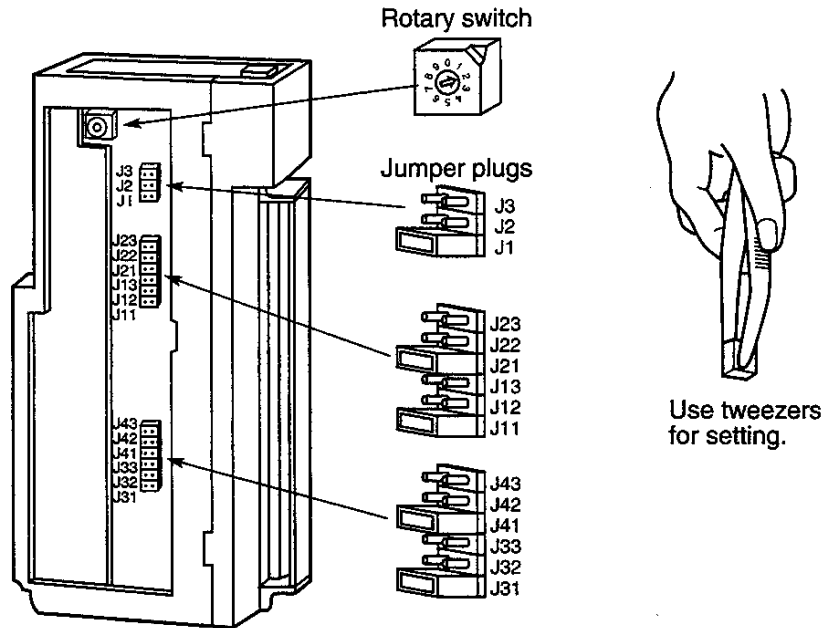

NOTE

- Set the rotary switch and the jumper plugs at the specified combination.
- Changing the output ranges will initialize the calibration data.
- Remove the module from the rack before setting.
- Do not touch other components on the printed circuit board of the module.
- The factory setting for the DA364 is ± 10 V, and that for the DA374 is 0 to 20 mA.
- Note that the module will not work correctly if the rotary switch and the jumper plugs are set other than the specified settings.
- Keep the extra jumper plugs, which may be needed to change the output range in the future.

2. Settings

(1) DA364

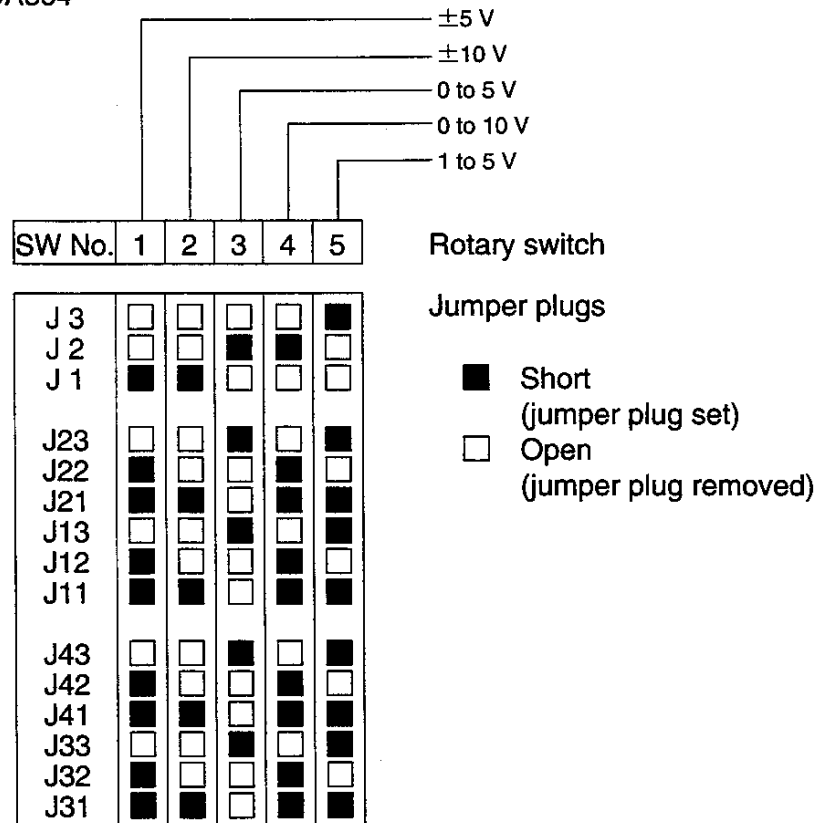

(2) DA374

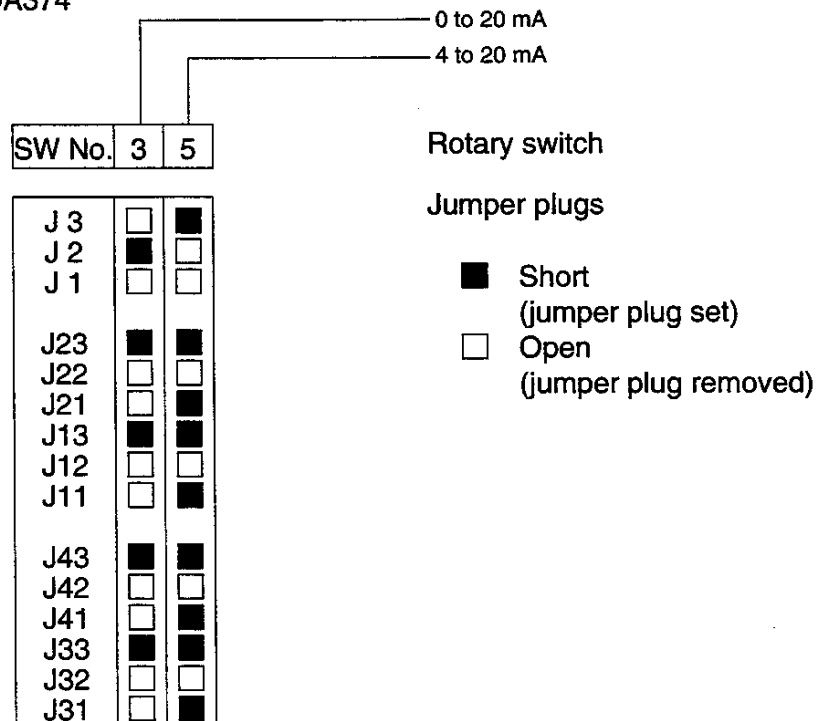

3. Installing and Wiring

3.1 Installing the module

Install the module in the following procedure.

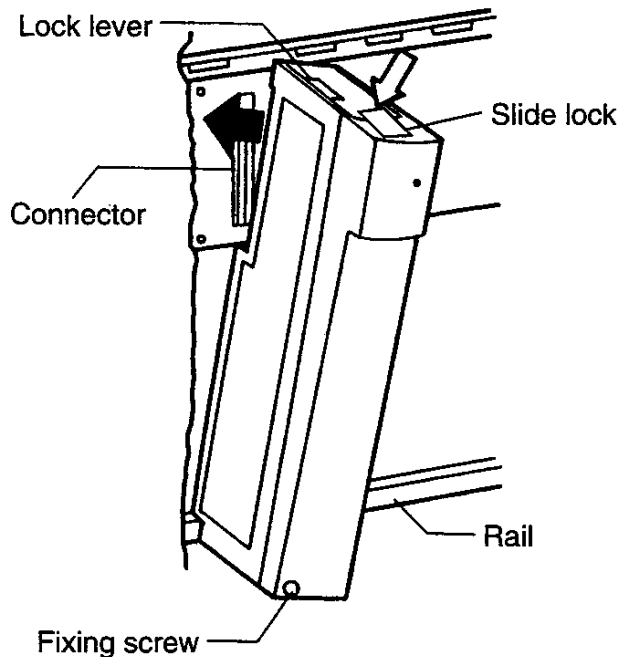

- (1) Slide back the slide lock on the top of the module and release the lock lever.
- (2) Hook the bottom end of the module with the lower rail, and push up the lock lever.
- (3) While setting the bottom of the module as the supporting point, install the module in the slot to fit the connector.
- (4) Release the lock lever and lock the module in the rack. Slide forward the slide lock and fix the lock lever.
- (5) Tighten the fixing screw with the module.



- Be sure that the screws of the module, CPU, and power supply are tightened firmly.

3. Installing and Wiring

3.2 Wiring

3.2.1 Terminal arrangement

Terminal No.	Terminal name	Function
1	ADJ	Open : normal mode
2		Short : calibration mode
3	1P	Analog output channel 1
4	1N	
5	1G	
6	2P	Analog output channel 2
7	2N	
8	2G	
9	3P	Analog output channel 3
10	3N	
11	3G	
12	4P	Analog output channel 4
13	4N	
14	4G	
15	24 Vdc	External 24 Vdc connection terminals (+)
16		(-)
17	LG	Line filter ground
18	FG	Frame ground
19	ALARM	Opened when error or power off
20		Shorted when normal

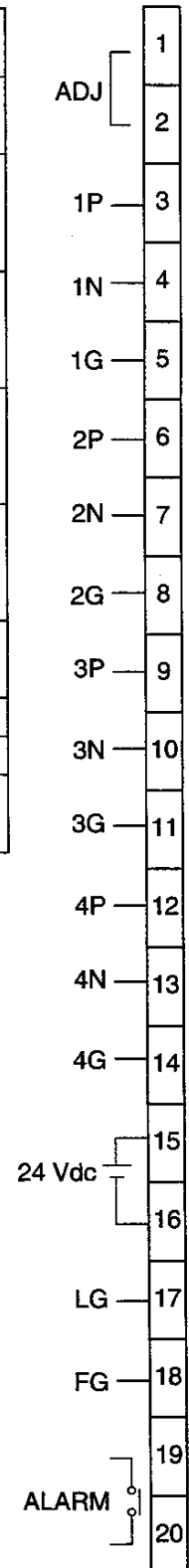

3. Installing and Wiring

3.2.2 How to wire (1) DA364

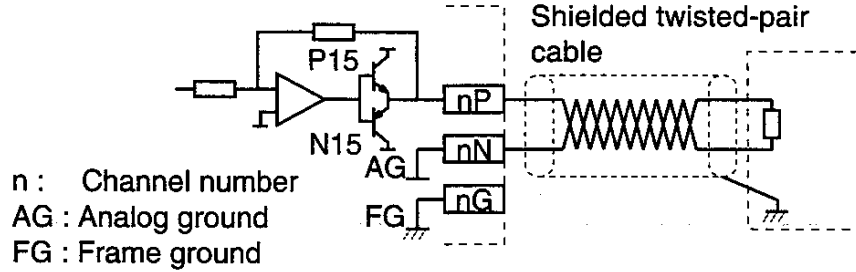

(2) DA374

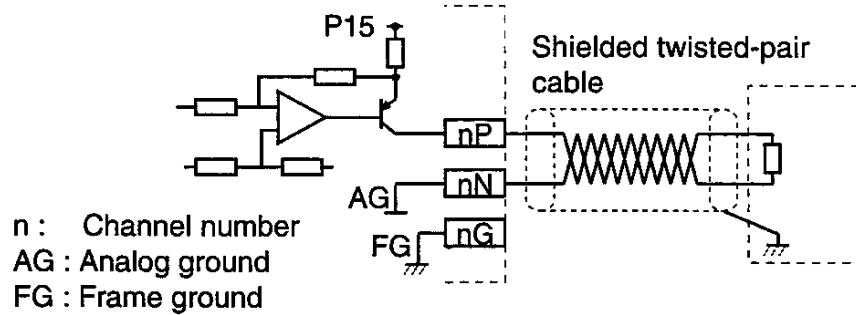

(3) External 24 Vdc connection

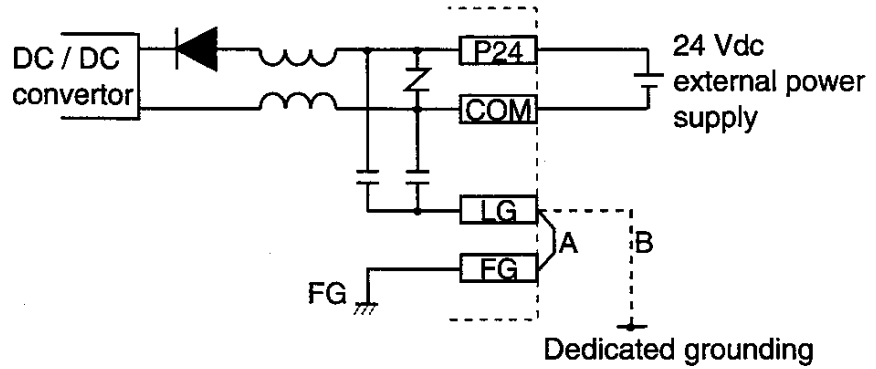

Normally, wiring A is performed. Depending on grounding condition, however, wiring is open, or wiring B is effective.

3.3 Application precautions

3.3.1 Installing environment

Do not install the DA364/DA374 in the following locations:

- Where the ambient temperature drops below 0 °C (32 °F) or exceeds 55 °C (131 °F);
- Where the relative humidity drops below 20% or exceeds 90%;
- Where there is condensation due to sudden temperature changes;
- In locations subject to vibrations that exceed tolerance;
- In locations subject to shocks that exceed tolerance;
- Where there are corrosive or inflammable gases;
- In locations subject to dust, machining debris or other particles; and
- In locations exposed to direct sunlight.

Also, observe the following precautions when installing an enclosure in which the T3 will be mounted.

- Provide the maximum possible distance between high-voltage or power panels. The distance must be at least 200 mm (8 inches).
- When installing an enclosure in the vicinity of high-frequency equipment, be sure to correctly ground the enclosure.
- When sharing the channel base with other panels, check for leakage current from the other panels or equipment.

3. Installing and Wiring

3.3.2 Wiring precautions

Observe the precautions below when installing and wiring the I/O modules.

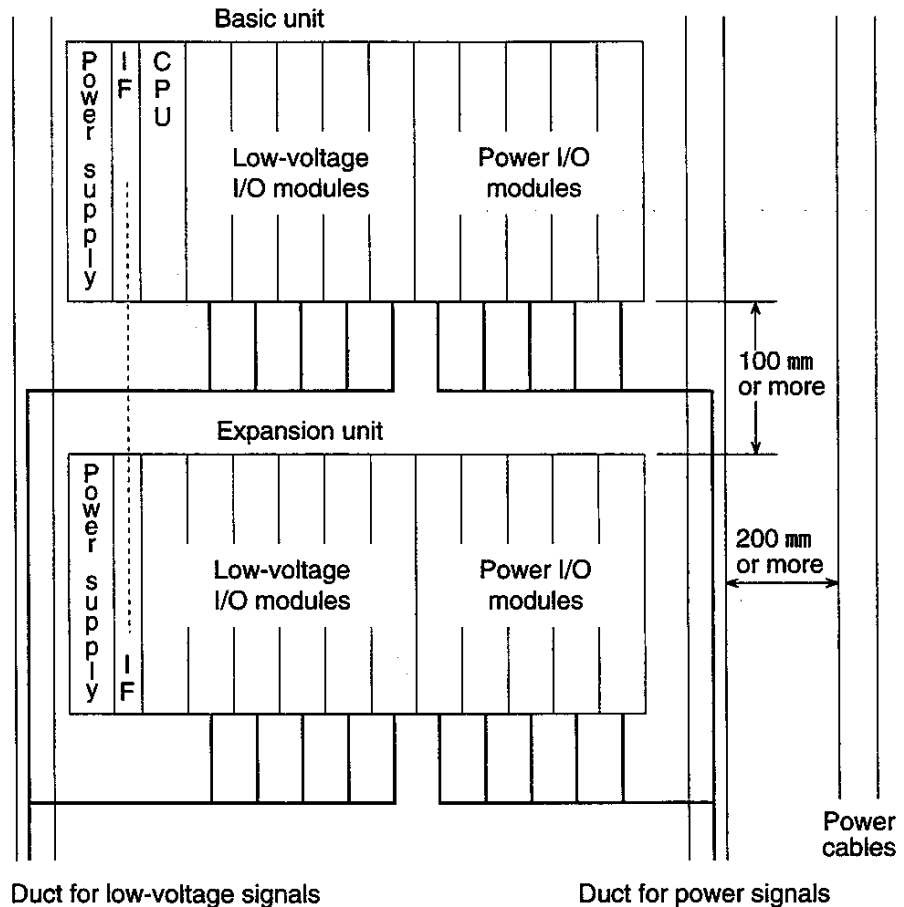

Low-voltage I/O modules
DC input module
Analog input module
Analog output module
Pulse input module
ASCII module
Transmission module

Power I/O modules
AC input module
DC output module
AC output module
Contact output module

- 1) Separate the low-voltage I/O modules (left side) and power I/O modules (right side) in layout and wiring.
- 2) keep a distance of 100 mm or more between the units for maintenance work and ventilation.
- 3) Keep the modules away from power cables and power equipment. The distance between them must be 200 mm or more, or use a steel plate to shield between them. (Ground the steel plate.)

4. Register Configuration

4.1 I/O registers and buffer memory

4 words of the output register (YW) are assigned to the DA364/374. As normal output, analog output values will be obtained by writing values in the corresponding YW registers. This module also has 32 words internal memory (called a "buffer memory") containing analog output data, status data, and calibration data. For reading the buffer memory, use the READ instruction.

(1) Module type

The DA364/DA374 have the following module type for I/O allocation.

Y 4W (4 words output)

(2) Register configuration

The analog output data of each channel will be allocated into the following I/O registers (YW), and, with batch I/O processing, the data in the YW registers of the T3 will be written into the DA364/DA374 as analog output data, as same as normal discrete outputs.

T3's I/O registers	
YWn	Analog output value channel 1
YWn + 1	Analog output value channel 2
YWn + 2	Analog output value channel 3
YWn + 3	Analog output value channel 4

n = 0, 1, 2, . . .

(Sample program)

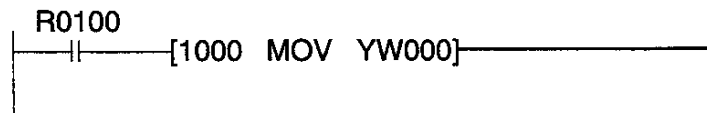

YW000 : Analog output value

When R0100 is ON, the constant value 1000 is transferred to YW000 as analog output data.

4. Register Configuration

(3) The configuration of the DA364/DA374 buffer memory is as follows:

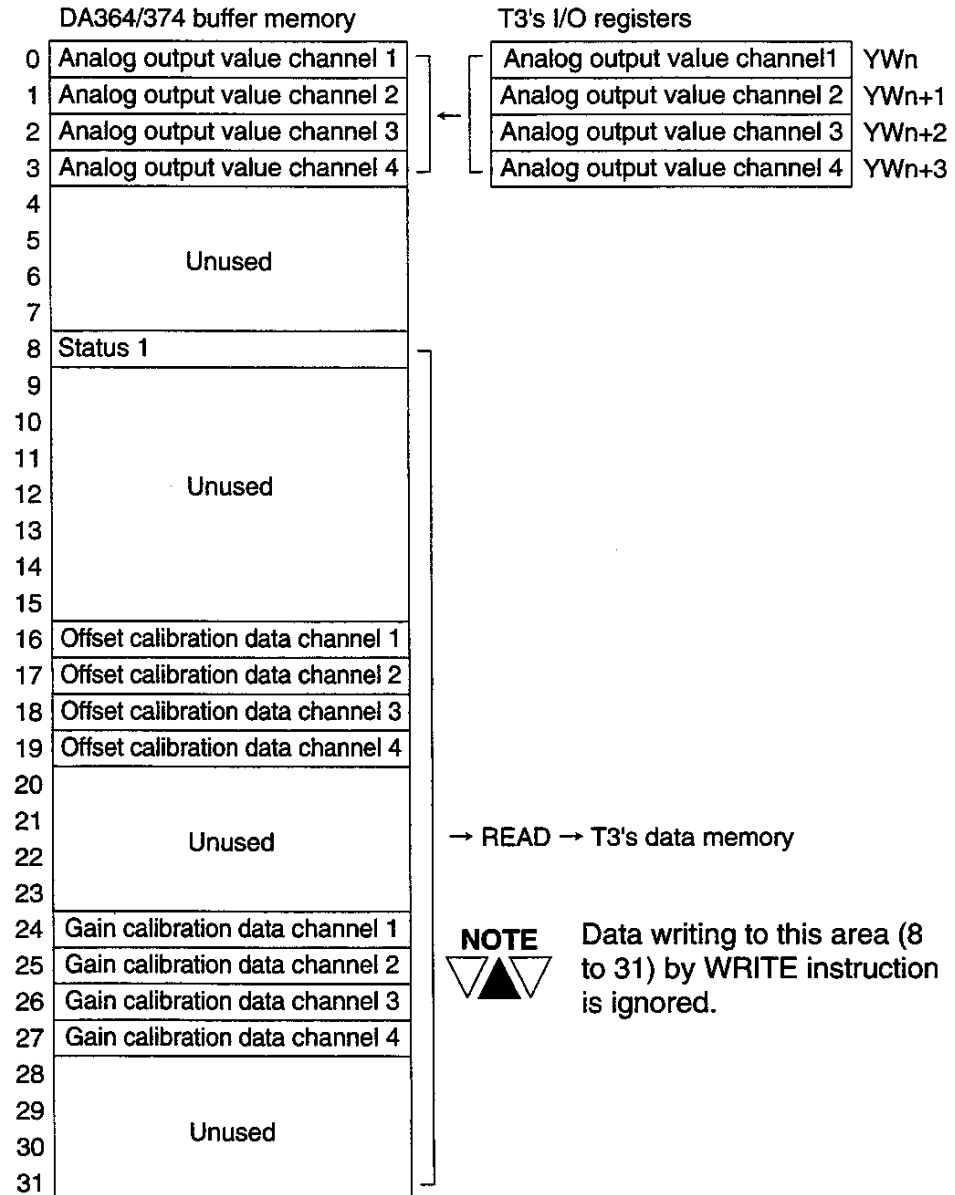

- The data of corresponding YW registers will be written into the module as analog output values.
- To monitor the status 1, offset calibration data, and gain calibration data, read the buffer memory contents into the T3's data memory by using the READ instruction. For details, see programming example on the next page.
- The analog output values for each channel can also be written directly into the buffer memory (0 to 3) by using the WRITE instruction or the I/O (direct input/output) instruction.

4. Register Configuration

(4) Reading the buffer memory

The buffer memory contents of the DA364/DA374 can be read into the desired registers by executing the READ instruction.

(Sample program)

In the case that YW000 to YW003 are assigned to the DA364/DA374, the following program reads the buffer memory of the module.

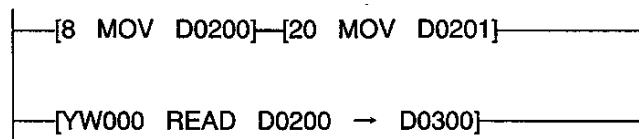

YW000 : Starting register assigned to the module

D0200 : Starting address of buffer memory to be read

D0201 : Number of words to be read

D0300 : Starting register of destination

DA364/DA374 buffer memory

T3 data memory

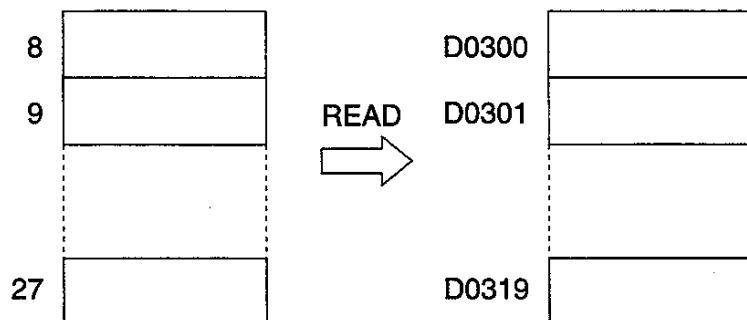

(5) Direct writing the analog output values

The analog output values can be written directly by using the WRITE instruction or the I/O (direct input/output) instruction.

(Sample program)

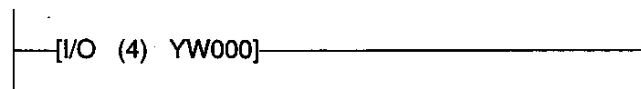

YW000 : Starting register assigned to the module

4. Register Configuration

4.2 Data format

4.2.1 Analog output data (0W to 3W)

(1) Bipolar mode ($\pm 5\text{ V}$, $\pm 10\text{ V}$)

The digital data of -2000 to 2000 will be converted into analog signals in full-scale (-5 to 5 V or -10 to 10 V). A 0.4% margin for both upper and lower limits is set.

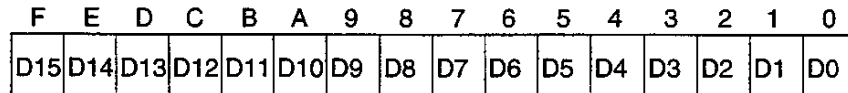

	Analog value		Digital value	
	$\pm 10\text{V}$	$\pm 5\text{V}$	Hex.	Integer
Upper limit	+10.040	+5.020	H07D8	2008
Full-scale (+)	+10.000	+5.000	H07D0	2000
0	0.000	0.000	H0000	0
Full-scale (-)	-10.000	-5.000	HF830	-2000
Lower limit	-10.040	-5.020	HF828	-2008

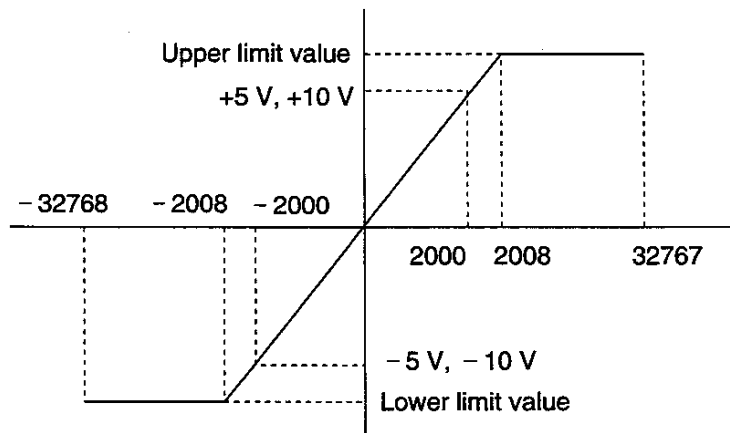

4. Register Configuration

(2) Unipolar mode (0 to 5 V, 0 to 10 V, 1 to 5 V)
(0 to 20 mA, 4 to 20 mA)

The digital data of 0 to 4000 will be converted into analog signals in full-scale (0 to 5 V, 0 to 10 V, 1 to 5 V, 0 to 20 mA, 4 to 20 mA). A 0.4% margin for the upper limit is set.

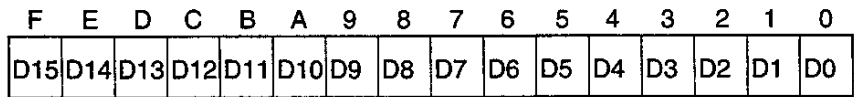

	Analog value					Digital value	
	0 - 5 V	0 - 10 V	1 - 5 V	0 - 20 mA	4 - 20 mA	Hex.	Integer
Upper limit	5.020	10.040	5.016	20.080	20.064	H0FB0	4016
Full-scale	5.000	10.000	5.000	20.000	20.000	H0FA0	4000
0 (lower limit)	0.000	0.000	1.000	0.000	4.000	H0000	0

0 to 5 V / 0 to 10 V / 0 to 20 mA

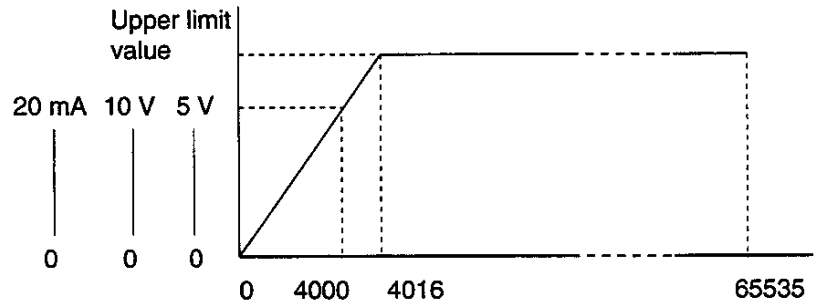

1 to 5 V / 4 to 20 mA

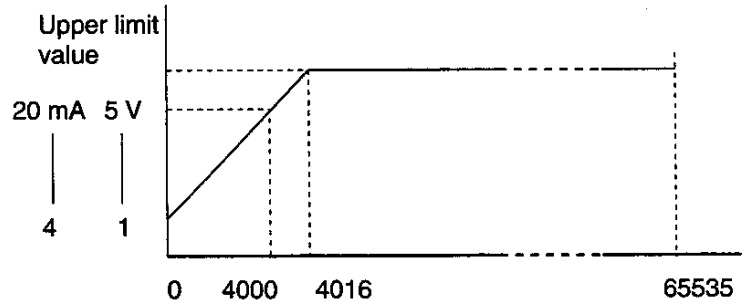

CAUTION The digital data is handled as unsigned integer (0 to 65535) in the module. Therefore, if a minus data is written as the analog output data, the upper limit value will be output.

4. Register Configuration

4.2.2 Status 1

Status 1 (address 8 of buffer memory) shows the output mode and error information.

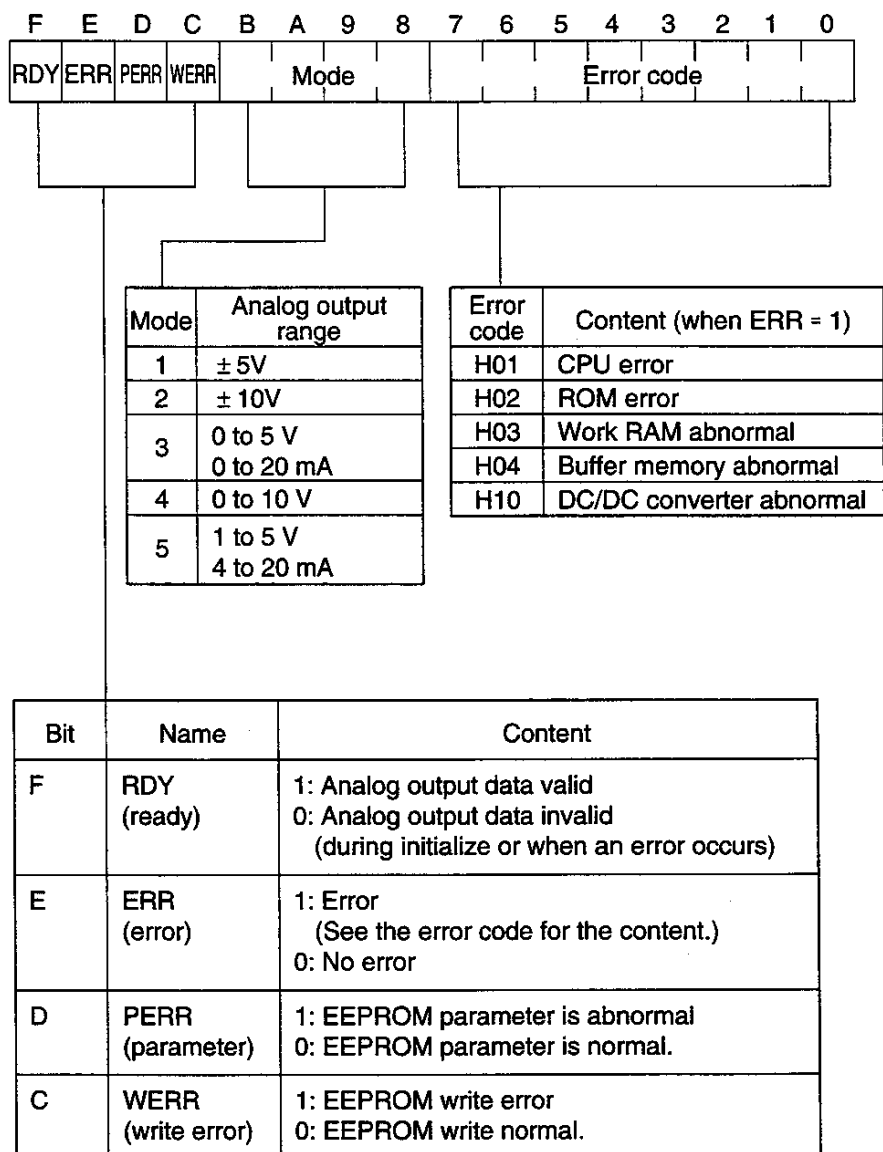

4. Register Configuration

4.2.3 Offset calibration data

The offset calibration data are stored in addresses 16 to 19 of buffer memory for each channel.

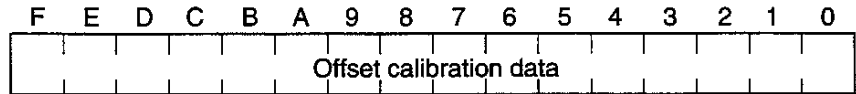

Mode	Valid range		
	Minimum value	No setting	Maximum value
$\pm 5\text{ V}$, $\pm 10\text{ V}$ (bipolar)	-200	0	200
0 to 5 V, 0 to 10 V, 1 to 5 V 0 to 20 mA, 4 to 20 mA (unipolar)	-400	0	400

NOTE  • Initial value is 0.
• Refer to Appendix C.

4.2.4 Gain calibration data

The gain calibration data are stored in addresses 24 to 27 of buffer memory for each channel.

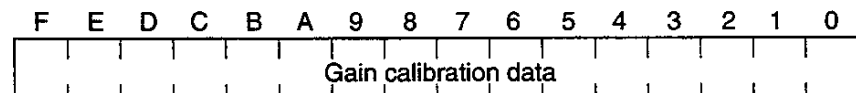

Mode	Range valid		
	Minimum value	No setting	Maximum value
$\pm 5\text{ V}$, $\pm 10\text{ V}$ (bipolar)	1800	2000	2200
0 to 5 V, 0 to 10 V, 1 to 5 V 0 to 20 mA, 4 to 20 mA (unipolar)	3600	4000	4400

NOTE  • Initial value is the no setting value in the above table.
• Refer to Appendix C.

Appendix

A Specification

Module type		DA364	DA374	
Output type		Voltage output	Current output	
Output method		Source output	Source output	
Output range	Bipolar	- 5 to + 5 V	—————	Set the mode by changing over Mode SW and the jumper.
		- 10 to + 10 V		
	Unipolar	0 to + 5 V	0 to 20 mA	
		0 to + 10 V	—————	
		1 to + 5 V	4 to 20 mA	
Load impedance		500Ω or more (10 V) 250Ω or more (5 V)	550Ω or less	
Output channel		4 channels / module (Y 4W)		
Resolution		12 bits / 0.025%		
Overall accuracy		± 0.2% at 25 °C		
Temperature drift		± 100 ppm/°C		
Conversion cycle		10 ms / 4 channels		2.5 ms / 1 ch
Insulation		Photo-coupler insulation (not isolated between the channels)		
Insulation resistance		10 MΩ		
Withstand voltage		500 Vac / 1 minute		
External power required		24 Vdc 10%		
Consumed current	Internal logic	180 mA (5 Vdc)		
	External power supply	200 mA (24 Vdc)		
Weight		500 g		

B Operation flow

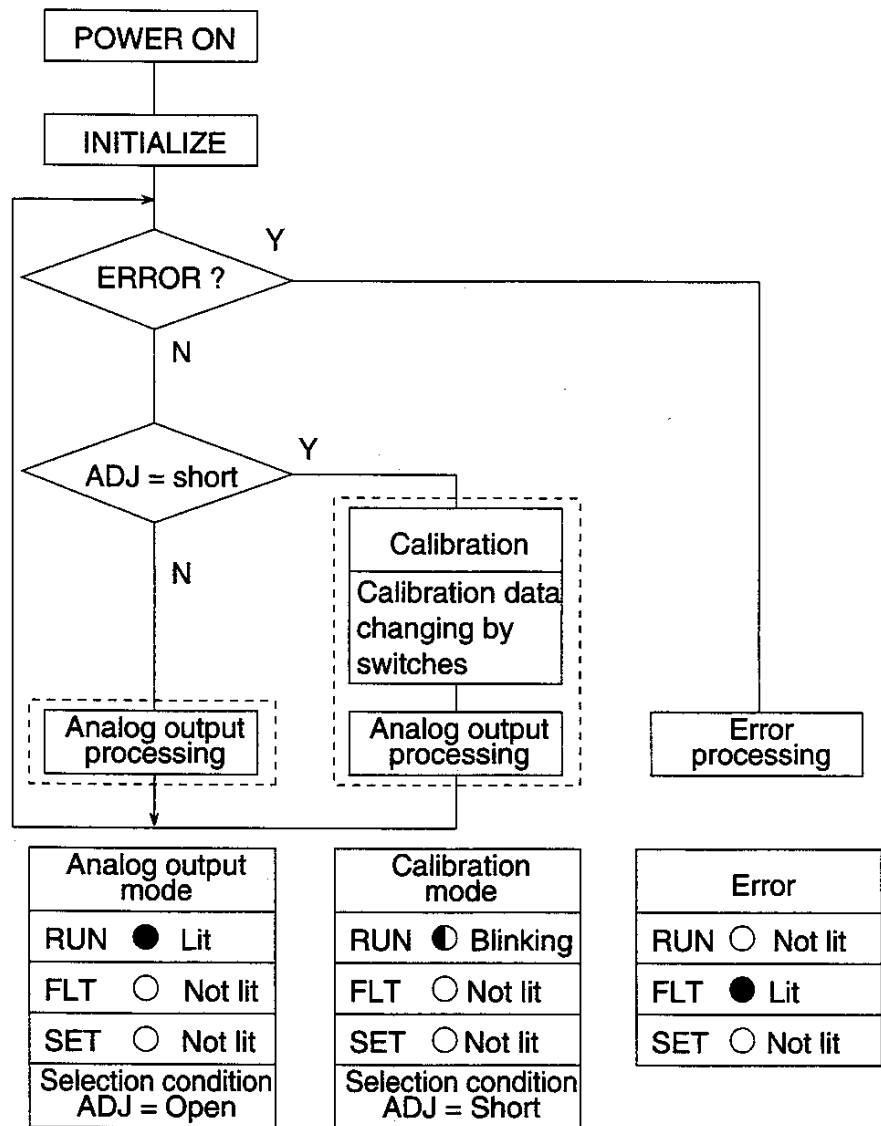

Analog output mode	
RUN	● Lit
FLT	○ Not lit
SET	○ Not lit
Selection condition ADJ = Open	

Calibration mode	
RUN	● Blinking
FLT	○ Not lit
SET	○ Not lit
Selection condition ADJ = Short	

Error	
RUN	○ Not lit
FLT	● Lit
SET	○ Not lit

Note: SET will be lit during write.

C How to calibrate

Performing gain and/or offset calibrations for output values will enable to adjust the environment for more accurate measurement. In the DA364/DA374, output data correction is carried out by using the gain and the offset calibration data as follows.

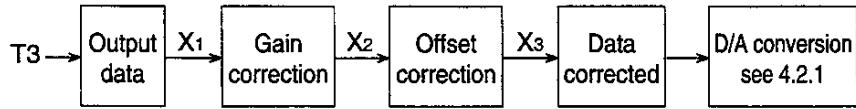

$$X_2 = X_1 \times \frac{G}{FS} \quad X_3 = X_2 + O$$

X_1 : Output data before corrections
 X_2 : Data after gain correction
 X_3 : Data after gain and offset corrections
 FS : Full-scale value
 G : Gain calibration value
 O : Offset calibration value

Example: In case that full-scale value = 4000 (0 to 10 V),
 gain calibration value = 4200,
 offset calibration value = 200,
 the correction will be as follows:

Analog output data (without correction)

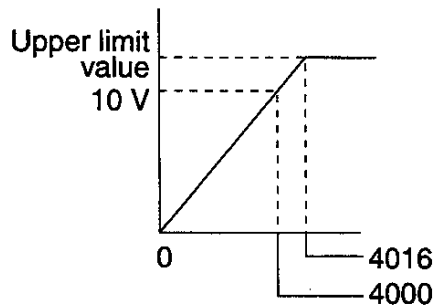

$$X_3 = \frac{4200}{4000} X_1 + 200$$

Analog output value after correction

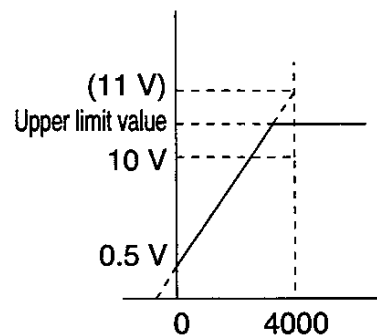

NOTE



- After correction, if the data for analog conversion exceeds the upper limit value, analog output values will be limited within the upper limit value.
- In the unipolar mode, minus data is not used in the module. If the output data is minus, the upper limit value will be output.

Actual calibration procedure is shown below.

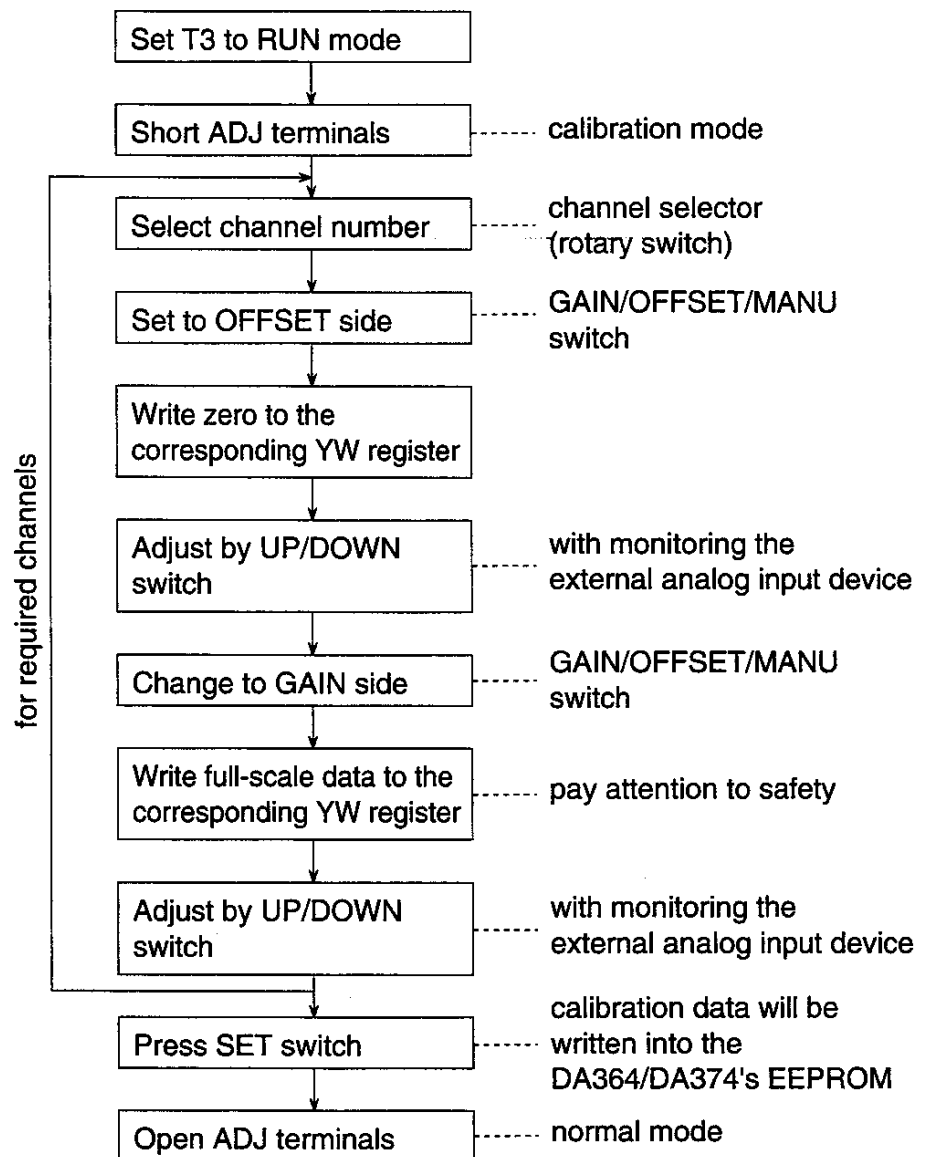

- NOTE**
- (1) The calibration data will be initialized when the output range is changed by the jumper plugs.
 - (2) This function is for adjusting within 10%. It is not a scaling function.

*** 1) Specifying the module by a constant.**

The special module can be specified by a constant data as follows.

$$(\text{Unit number}) \times 256 + (\text{Slot number})$$

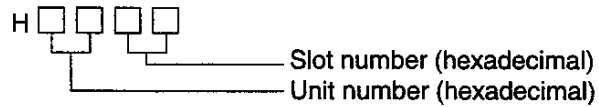

Unit number	Hexadecimal
0	00H
1	01H
2	02H
3	03H

Slot number	Hexadecimal
0	00H
1	01H
2	02H
3	03H
4	04H
5	05H
6	06H
7	07H
8	08H
9	09H
10	0AH

*** 2) The READ instruction will become an error in the following cases (setting S0051). No data will be transferred in error.**

- When the operand A is other than a constant or XW/YW register.
- When the specified module has been disconnected.
- When the no answer error occurs with the specified module.
- When the number of words transferred exceeds 256 words.
- When the source of transfer is out of the range specified.
(address + size exceeds the limit)
- When the destination of transfer is out of the range specified.
(address + size exceeds the limit)

Appendix

E Details of the WRITE instruction

FUN 238 Special module data write (WRITE)	Related instruction Special module data read (READ)
Will write data into the special module.	

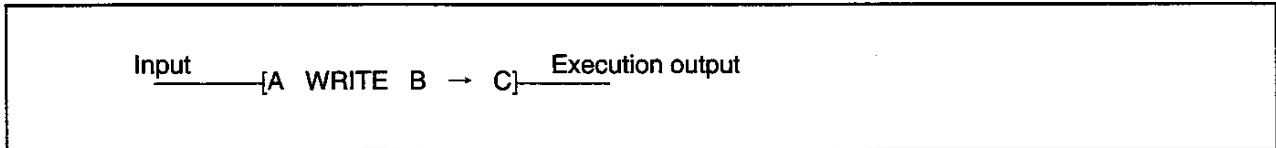

Function

- Will transfer data from the T3's registers into the buffer memory of the special module.

Input	Action	Output	ERF
OFF	Not executed	OFF	
ON	Execution: in normal operation	ON	
	Not executed: in error (*2)	ON	ON

Operand

opr	Name	Device										Register										Constant	Index					
		X	Y	S	L	R	Z	T	C	I	O	XW	YW	SW	LW	RW	W	T	C	D	F			IW	OW	I	J	K
A	Top register of source																											
B	Transfer parameter																											
C	slot/register																											

Program example

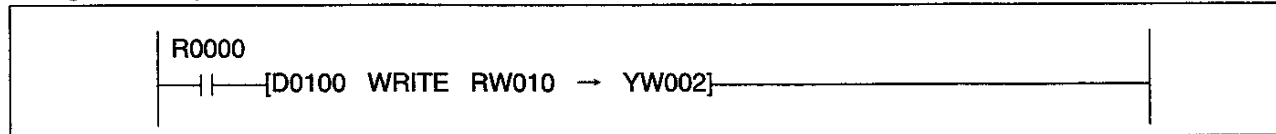

Operation

- When R0000 is ON, the register data of the size indicated by RW011, starting with D0100, are transferred to the buffer memory starting at the address indicated by RW010 of the special module allocated to YW002.
- The maximum number of words to be specified in RW011 is 256 words.

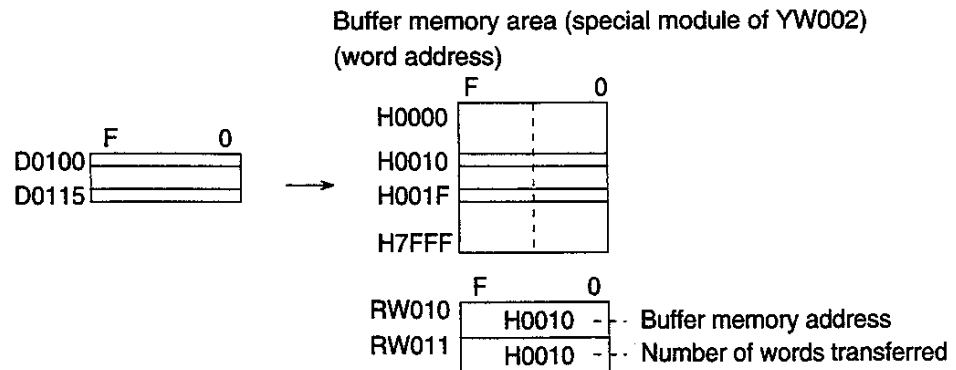

When a constant is used for the operand C, refer to the setting method on the next page. (*1)

*** 1) Specifying the module by a constant.**

The special module can be specified by a constant data as follows.

$$(\text{Unit number}) \times 256 + (\text{Slot number})$$

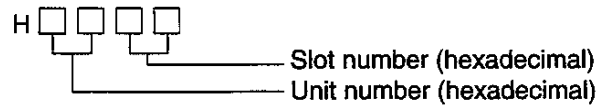

Unit number	Hexadecimal
0	00H
1	01H
2	02H
3	03H

Unit number	Hexadecimal
0	00H
1	01H
2	02H
3	03H
4	04H
5	05H
6	06H
7	07H
8	08H
9	09H
10	0AH

*** 2) The WRITE instruction will become an error in the following cases (setting S0051). No data will be transferred in error.**

- When the operand C is other than a constant or XW/YW register.
- When the specified module has been disconnected.
- When the no answer error occurs with the specified module.
- When the number of words transferred exceeds 256 words.
- When the source of transfer is out of the range specified.
(address + size exceeds the limit.)
- When the destination of transfer is out of the range specified.
(address + size exceeds the limit.)

TOSHIBA

TOSHIBA INTERNATIONAL (EUROPE) LTD.

1 Roundwood Avenue
Stockley Park, Uxbridge
Middlesex UB11 1AR, ENGLAND
Tel: 081 848 4466 Fax: 081 848 4969
Tlx: 265062 TSB LDN G Cable: Toshibaic London.

TOSHIBA INTERNATIONAL CORPORATION

Industrial Equipment Division
13131 West Little York Road
Houston, Texas 77041, U.S.A.
Tel: 713-466-0277 1-800-231-1412 Telex: 762078

TOSHIBA INTERNATIONAL CORPORATION PTY. LTD.

Unit 1,9 Orion Road, Lane Cove
N.S.W. 2066, AUSTRALIA
Tel: 02-428-2077 Telex: AA25192

TOSHIBA CORPORATION

Industrial Equipment Department
1-1, Shibaura 1-chome, Minato-ku, Tokyo 105, Japan
Tel: (03)3457-4900
Cable: TOSHIBA TOKYO

Free Manuals Download Website

<http://myh66.com>

<http://usermanuals.us>

<http://www.somanuals.com>

<http://www.4manuals.cc>

<http://www.manual-lib.com>

<http://www.404manual.com>

<http://www.luxmanual.com>

<http://aubethermostatmanual.com>

Golf course search by state

<http://golfingnear.com>

Email search by domain

<http://emailbydomain.com>

Auto manuals search

<http://auto.somanuals.com>

TV manuals search

<http://tv.somanuals.com>