

## PROGRAMMABLE LOGIC CONTROLLERS



### Operator Interface Stations

**XT**

**Reliability in motion™**



- **Data Entry and Display for Toshiba Automation Products**
- **Direct Connection as Modbus Master or Slave**
- **Wizards for Rapid Application Development**
- **Support for Floating Point Data (Toshiba Loop Controllers)**
- **Multiple Language Capability**
- **Non Programmable, Inexpensive OEM Models Available**

# OIS PRODUCTS

## KEY PADS

### OIS10/20

2 Line x 16 Display



### OIS15

4 Line x 16 Display



### OIS40/40R

4 Line x 20 Display

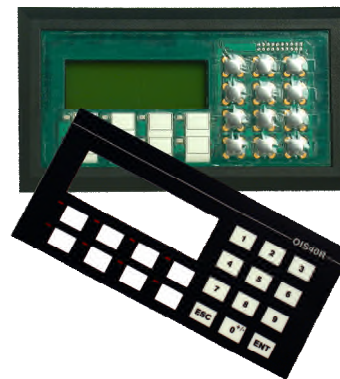

## TOUCH SCREENS

### OIS120

12" Color Display

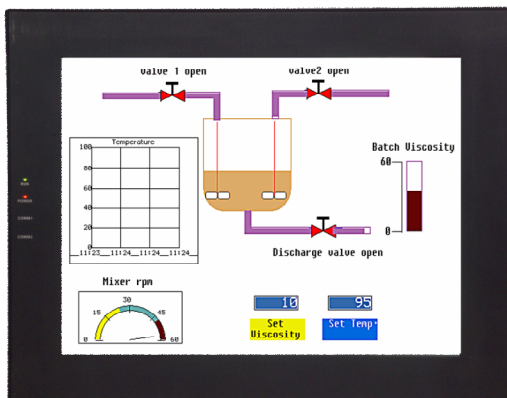

### OIS50

4.1" LCD Display



### OIS60

6" Color Display



# KEY FEATURES

## **Ethernet Port on OIS120**

Use for programming, connection to PLC, or connection to higher level controller. Communicate across the plant or across the country.

## **Multi Language Capability**

Display text information in any Microsoft supported language. Export text file to co-worker in another country so that he can add his language. Then import text into OISeup32 software.

## **Pop Up Screens & Keypads**

Conserve screen space on touchscreens by popping up a keypad for data entry. Press a flashing alarm button to display a detailed alarm screen.

## **Alarm and Event Monitoring**

Monitor status of alarms and specific events on one screen.

## **Trending**

Touchscreens can display process trends graphically for easy interpretation of process/machine history.

## **Horizontal or Vertical Orientation**

Mount the touchscreen so that it best fits the application. Screens can be created in either horizontal or vertical format.

## **Support for Floating Point Data**

IEEE format double register data can be attached to any screen object such as bargraphs, meters, etc.

## **Serial Port Available for Printing Screens and Alarm Data**

Send PLC or connected device information to any serial printer.

## **Low Cost OEM Keypad Models that Require No Programming Software**

Use large memory capacity of Toshiba PLC to store messages and perform data entry.

## **Keypad Overlays Ship Separately on most Keypad Models**

Allows OEMs to easily add custom overlay for specific application.

# Color Touch Screens

## Operator Interface Stations For Toshiba Industrial Equipment



**T-Series PLCs**

**Loop  
Controllers**



**Adjustable  
Speed Drives**



**V-Series  
Controllers**

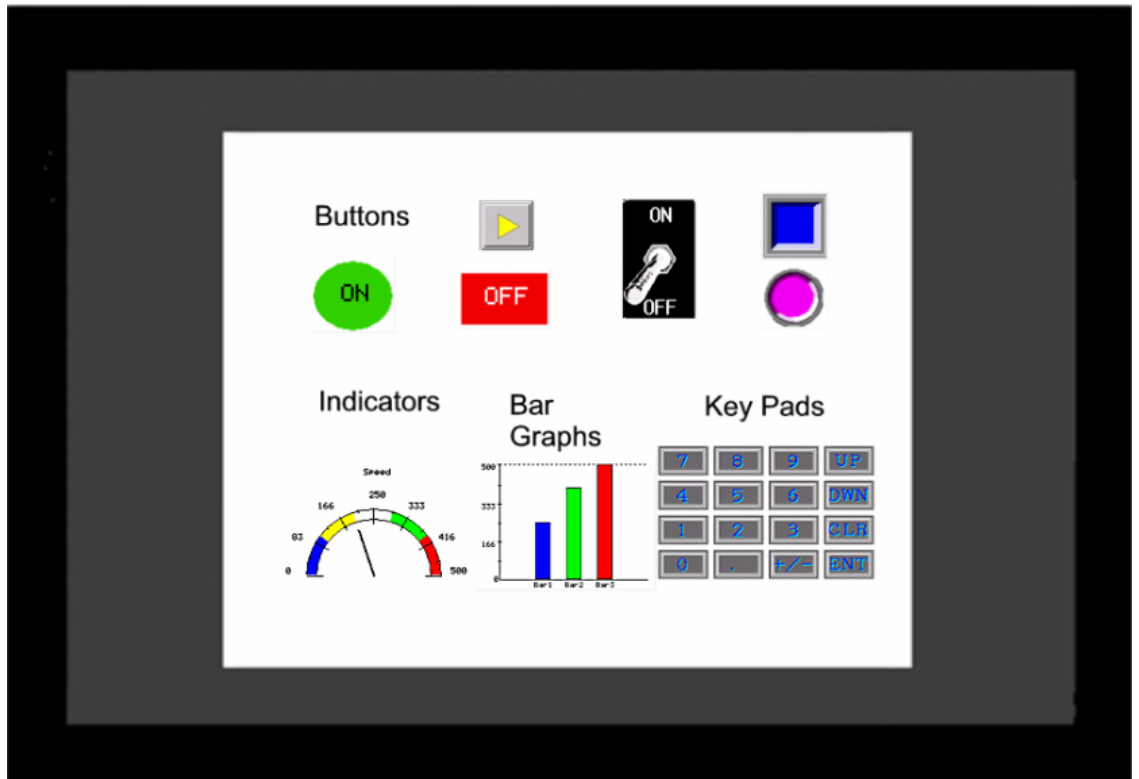

*Please Touch Me*

*I want to communicate with Toshiba*

# TOUCHSCREENS

## Programming

OIS operation is based on screens and tasks. Screens are created with objects on the screen. Tasks are assigned to the objects. The maximum limit to the number of screens that can be created is 65,534 (based on available memory). Up to 256 alarms can be defined. Recipes can be block transferred between the OIS and connected devices (or vice versa). The following connection modes are possible:

- 1 : 1 OIS connected to one device.
- 1 : N One OIS connected to multiple devices
- N : 1 Multiple OISs connected to one device  
(Requires Gateway Protocol Converter).

Before the OIS can be used a program must be loaded into it. The program is created on any MS Windows based computer using the OISetup32 software. The OISetup32 software creates nodes, tasks, tags and screens. Tasks and tags are then assigned to the screens and to objects on the screens. Available tasks are:

▶ Go To Screen	▶ Call Popup	▶ Display Trend
▶ Write Value to Tag	▶ Add Constant to Tag	▶ Subtract Constant from Tag
▶ Copy Tag A to Tag B	▶ Swap Tag A & Tag B	▶ Copy Tag to LED
▶ Copy PLC Bk to Recipe Bk	▶ Copy Recipe Bk to PLC Bki	▶ Print Data
▶ Turn Bit <b>ON</b>	▶ Turn Bit <b>OFF</b>	▶ <b>Toggle Bit</b>

The setup screen with floating tools bars, text grid and touch grid (grids are adjustable) is used to create screens with objects. Tasks are then assigned to the objects..

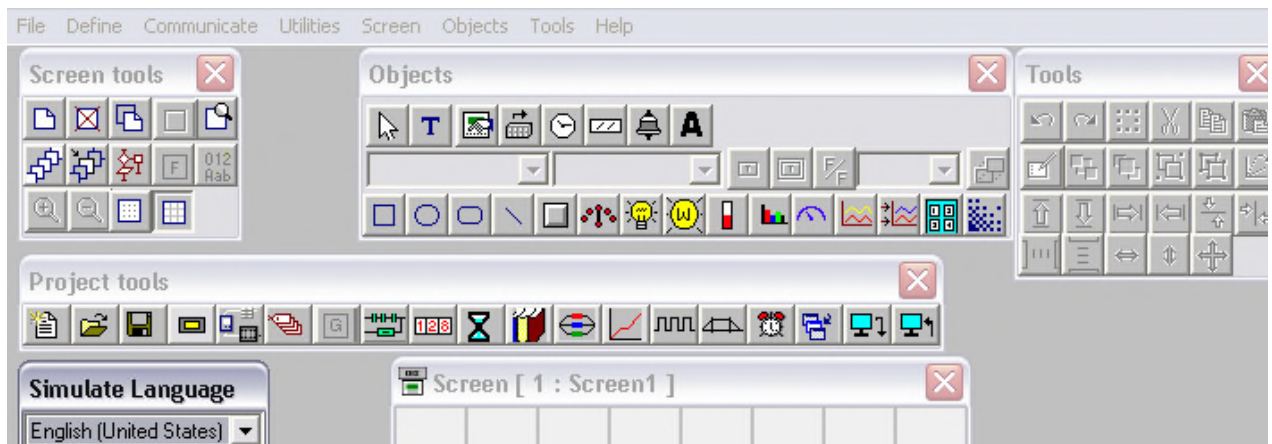

- Notes:
1. Most new features require Ver. 3.11 or higher.
  2. Ver. 3.11 requires MS Windows 2000 or higher.

## Multiple Language

Nós Falamos Português

Мы Показываем русский язык

Se Habla Muchos Idiomas de Espanol

OIS60

OIS50

私たちは、日本語が話せます

Nous Parlons le Français

We Speak a Lot of Different English

**If Microsoft Supports the Language, We can Display It**

Let Us Speak Your Language

If multiple languages are present in the OIS, the user can toggle back and forth between languages. There are two ways to add multiple languages to the OIS. 1<sup>st</sup>, the program developer can enter labels in both languages during program development in the OISet32 software. Or 2<sup>nd</sup>, the program developer can export labels/text objects to an ASCII file with the language conversion utility. Then the ASCII file can be sent to another person who is native in the second language. This person can add the translations to the text file and send it back to the developer who then imports it back into the OISetup32 software.

## Multi-State Indicators

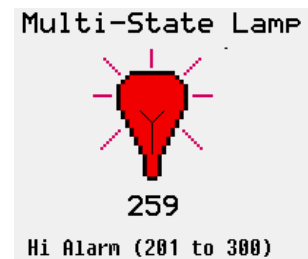
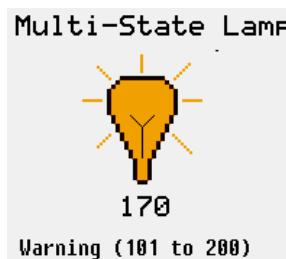
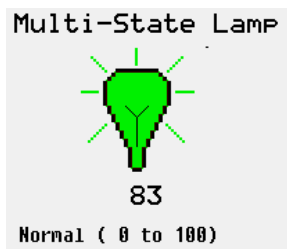

Colors and text can change based on ON/OFF bit status or register values in the PLC. For OIS50 (monochrome LCD) varying gradient fill patterns can be used to represent different states. Not satisfied with the available indicators? The OISetup32 software allows importing of custom designed bitmap objects that can be used in place of available objects.

## Meters, Bargraphs & Switches

A wide variety of predefined meters, bargraphs, buttons, and switches are available for insertion on an OIS development screen. User defined bitmap images can be imported into the OISetup32 software and used just like predefined buttons and switches.

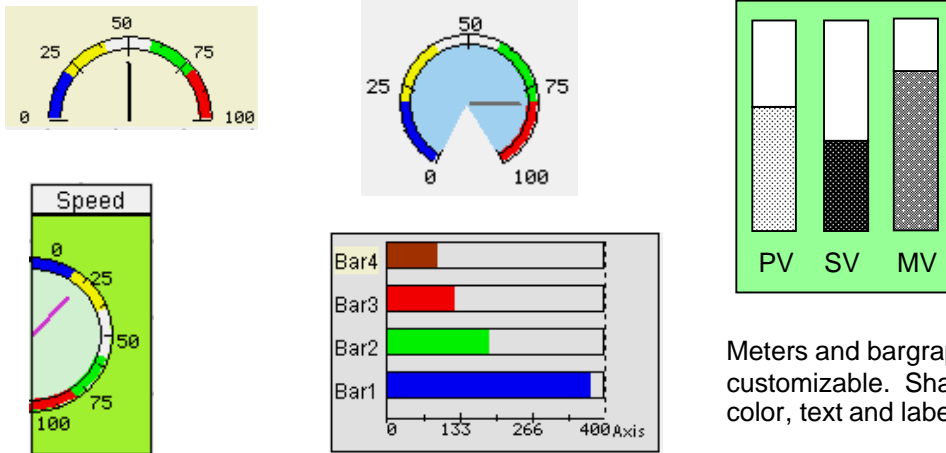

Meters and bargraphs are very customizable. Shape, orientation, fill, color, text and labels are all modifiable.

Switch Pairs: One or the other appears depending on status of a bit in the PLC.

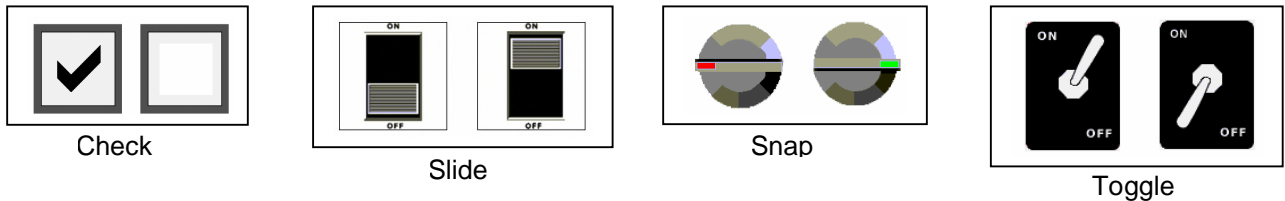

## Trending

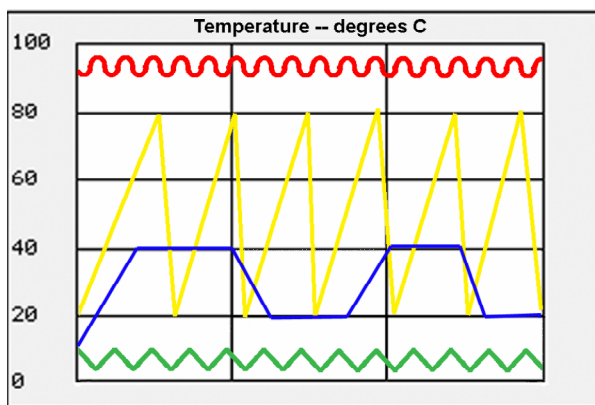

Trending is an important requirement in most process applications and many machine control applications. Displaying trends graphically provides easier interpretation of process/system change. Two types of trending are available in the OIS60 and OIS120.

1. Simple Trending: Variables are displayed on the user defined screen. Variables are on the Y-axis and time is on the X-axis. Time is displayed in seconds / minutes by user defined increments. The bar colors and the number of grid lines are also user definable.

2. Historical Trending: Historical trending is simple trending plus data logging. With historical trending the data values are saved to the OIS internal memory. When to start and stop trending is user defined. What to do when OIS memory is fully (stop or overwrite) is user defined. In the data logger 4 groups can be defined, each group containing up to 32 tags. When to start logging and stop logging is user definable for each group. Multiple trending windows can be displayed but each window is limited to 4 tags.

## Popup Keypads for Data Entry

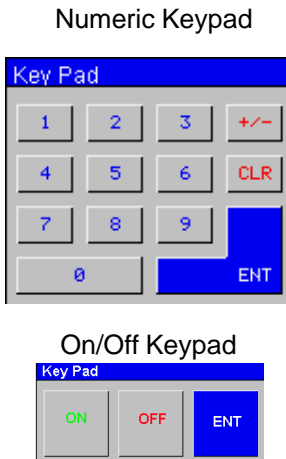

A variety of keypads are available to simplify data entry. The keypads can be incorporated into screen design or can be "popped up" when a button or other object is pressed on the screen so that they appear only when needed. Key text, key size and keypad color are all user definable.

## Horizontal or Vertical Orientation

OISetup32 software allows the display to be oriented in the most advantageous position for the operator (or as necessary based on available front panel space). Simply rotate the objects or text in the direction desired when setting up the display in the OISetup32 software.

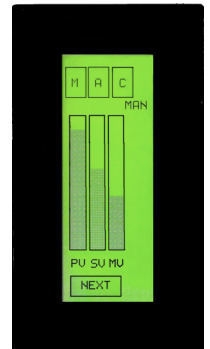

Requires OISetup32 Ver. 3.11 or higher

## Ethernet Connection (OIS120)

Multiple OIS120s can connect to S2T PLCs (with the GEN651A Ethernet Module) in a 100 Mhz Ethernet network.

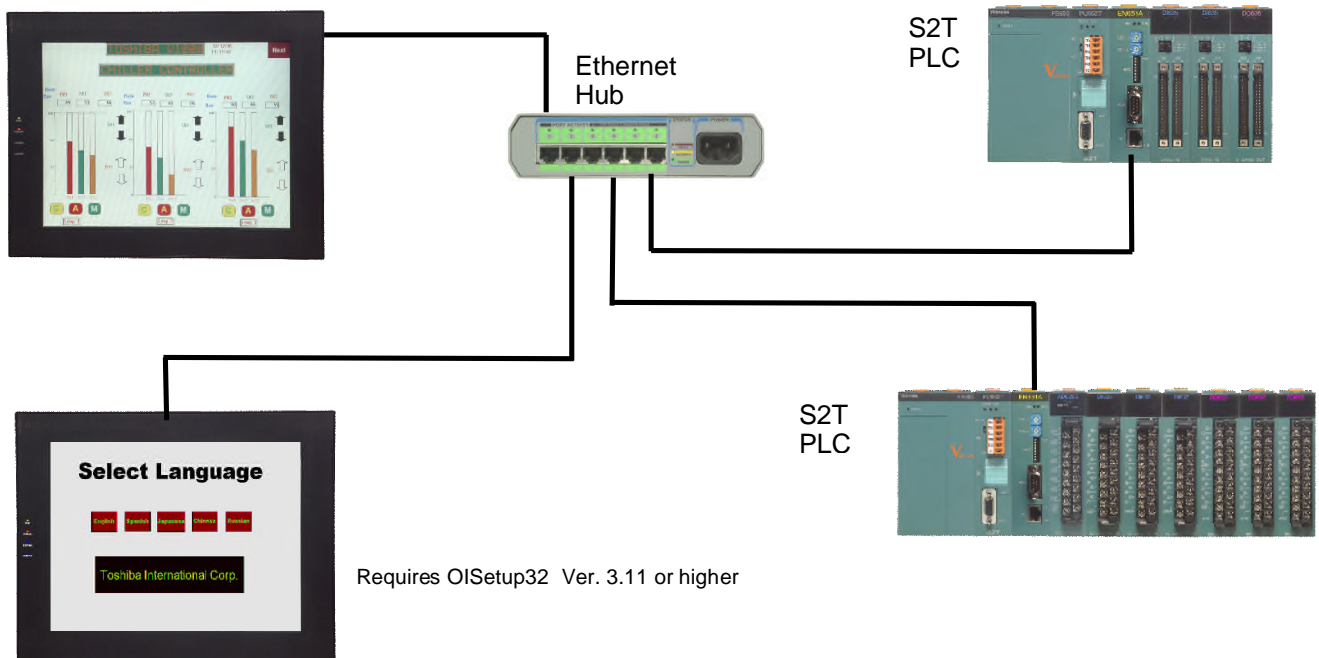

Requires OISetup32 Ver. 3.11 or higher



# KEYPADS

## Low Cost Non Programmable Models



**OIS15**  
**4 Line x 16 Display**  
**8 Function Keys**  
**4 Indicator LEDs**  
**Power from PLC**

**OIS10**  
**2 Line x 16 Display**  
**6 Function Keys**  
**2 Indicator LEDs**  
**Power from PLC**

The OIS10/15 are economical, low cost, OEM type operator interface stations. They have no external power connections, they have no memory; they depend exclusively on the PLC. Fortunately Toshiba's T1 Series PLCs have additional power and memory capacity to make the OIS10/15 very powerful operator interface stations. For detailed examples on how to make the OIS10/15 into full function operator interface stations please see Toshiba's T-Series Quick Start Manual. Keypad overlays are shipped separately. They can be easily replaced by OEM custom Keypad overlays.

**Message Display:** Store ASCII messages in the ladder logic

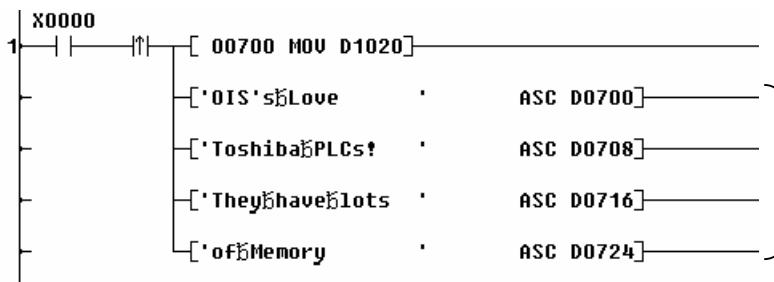

*OIS's Love  
 Toshiba PLCs!  
 They have lots  
 of Memory*

**Data Entry:** Create a menu of screens for changing different parameters.

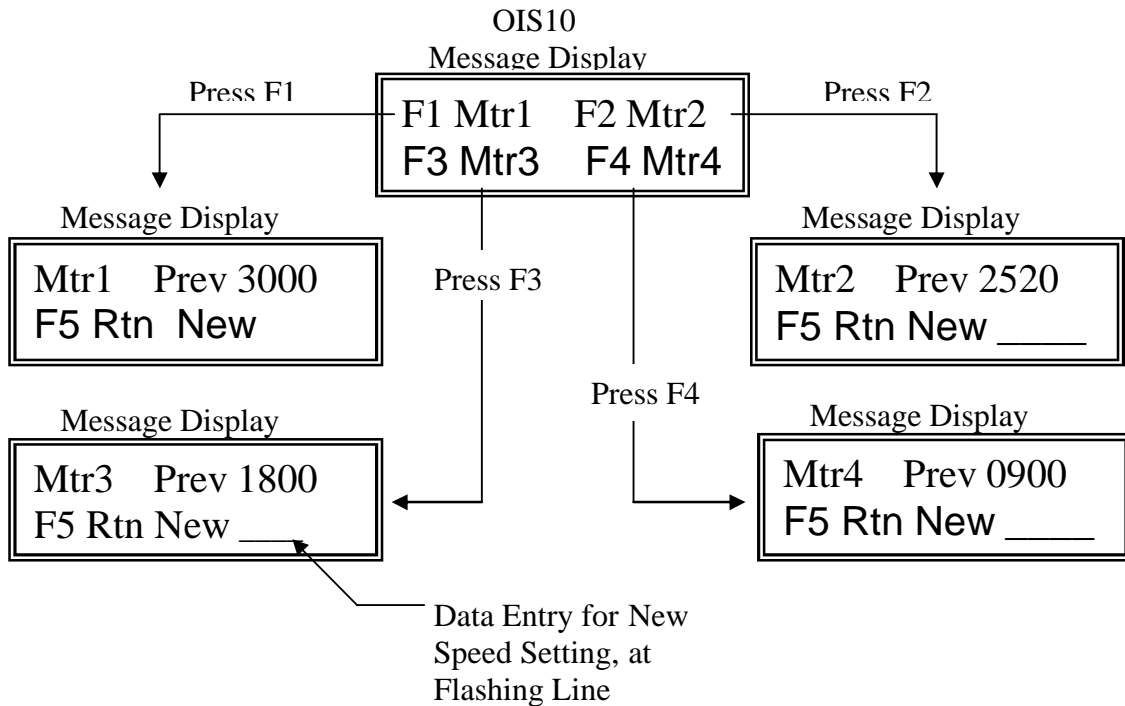

**ANNUNCIATOR LEDs:** The OIS10 has 2 user definable LEDs, the OIS15 has 4 user definable LEDs. Each LED can be turned ON or OFF when a designated coil or bit in the PLC is ON or OFF. Each designated LED can also be turned ON when one of the following occurs: A register value is less than, equal to, or greater than a specified limit.

## OIS40/40R



	<b>OIS40</b>	<b>OIS40R</b>
Display	4 lines x 20 ch.	4 lines x 20 ch.
Power	From PLC	Separate 24 Vdc
Connection	PLC RS232 Port	PLC RS485 Port
Prgm Sfwr	OISetup32	OISetup32
Fun Keys	8	8
LEDs	8	8

The OIS40 and the OIS40R have full function numerical keypads for applications requiring repetitive data entry.

The OIS40R is the remote version with the RS485 connection to the PLC. It can be mounted up to 1000 meters ( 0.6 miles) away from the PLC. One (1) OIS40R can talk to multiple PLCs. Both the OIS40 and the OIS40R use the same OISetup32 software used by the touchsreen OISs.

# SPECIFICATIONS

## General Specifications

Operating Temperature:	0°C to 50°C
Storage Temperature:	-20°C to 80°C
Humidity:	10% to 90% (Non condensing)
Immunity to ESD:	Level 3 as per IEC1000-4-2
Immunity to Transients:	Level 3 as per IEC1000-4-4
Radiated Susceptibility:	Level 3 as per IEC1000-4-3
Emissions:	EN55011 CISPR A

## OIS120

Display:	12.1" TFT (800 x 600 Pixels) Graphical Color Display (256 Colors)
Display Rating:	IP 65 rated Touch Screen.
Panel Cutout:	294 mm x 226 mm.
Communication Ports:	Two ports, one connects to the PLC and one for programming, serial printing or connecting to another device with different protocol. RS232/485/CMOS levels available.
Ethernet Port:	Connects to PLC, Available for Programming or Use for Remote Monitoring.
Certifications:	CE,
Power:	24 Vdc $\pm$ 10%, 20 W maximum, Inrush 2 A.
Weight:	2.8 Kg.

## OIS60

Display:	6" diagonal QVGA, 320 x 240 pixel, 256 color, Backlit .
Display Rating:	IP 65 rated Touch Screen.
Panel Cutout:	183.13 mm x 125.12 mm .
Communication Ports:	Two ports, one connects to the PLC and one for programming, serial printing or connecting to another device with different protocol. RS232/485/CMOS levels available.
Certifications:	CE,
Power:	24 Vdc $\pm$ 10%, 3 W maximum.
Weight:	645 g.

## OIS50

Display:	4.1" 192 x 64 pixel LCD Graphical Display.
Display Rating:	IP 65 rated Touch Screen.
Panel Cutout:	132.2 mm x 68.6 mm.
Communication Ports:	Two ports, one connects to the PLC and one for programming, serial printing or connecting to another device with different protocol. RS232/485/CMOS levels available.
Certifications:	CE,
Power:	24 Vdc $\pm$ 10%, 3 W maximum.
Weight:	276 g.

## OIS40/40R

Display:	4 Line x 20 Character Backlit LCD.
Display Rating:	IP 65 rated Keypad
Keys	8 Function User Assignable Keys & 0 – 9 Numeric Data Entry Keys
LEDs	8
Panel Cutout:	162 mm x 79 mm.
Communication Ports:	OIS40R: Two ports, one connects to the PLC and one for programming or serial printing.
Certifications:	CE, $\mu$ CSA
Power:	OIS40R: 24 Vdc $\pm$ 10%, 2 W maximum. OIS40: 5 Vdc $\pm$ 5%, 160 mA from PLC Port.
Weight:	OIS40: 235 g. OIS40R: 350 g.

## OIS20

Display:	2 Line x 16 Character Backlit LCD.
Display Rating:	IP 65 rated Keypad
Keys	6 User Assignable Function Keys.
LEDs	2 (1 Red & 1 Green)
Panel Cutout:	92 mm x 45 mm (1/8 DIN).
Communication Ports:	Two ports, one connects to the PLC and one for programming or serial printing.
Certifications:	CE, $\mu$ CSA
Power:	5 Vdc $\pm$ 5%, 120 mA from PLC Port.
Weight:	140 g.

## OIS10/15

Display:	OIS10: 2 Line x 16 Character Backlit LCD. OIS15: 4 Line x 16 Character Backlit LCD.
Display Rating:	IP 65 rated Keypad
Keys	OIS10: 6 User Assignable Function Keys. OIS15: 8 User Assignable Function Keys.
LEDs	OIS10: 2 (1 Red & 1 Green) OIS15: 4 Red.
Panel Cutout:	OIS10: 92 mm x 45 mm. (1/8 DIN). OIS15: 92 mm x 92 mm (1/4 DIN).
Communication Ports:	One port connects to the PLC.
Certifications:	CE, $\mu$ CSA
Power:	5 Vdc $\pm$ 5%, 120 mA from PLC Port.
Weight:	OIS10: 140 g. OIS15: 240 g.

# DIMENSIONS

**OIS10/20**

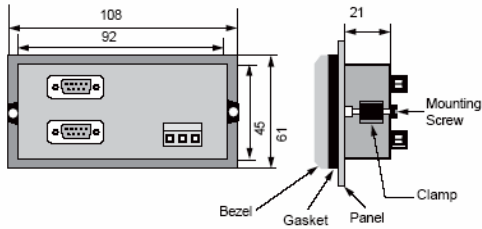

**OIS15**

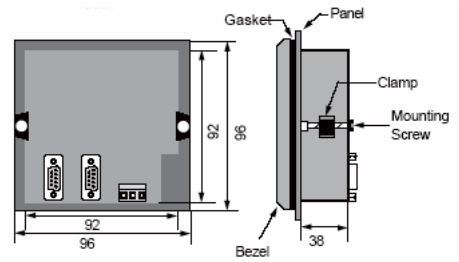

**OIS40/40R**

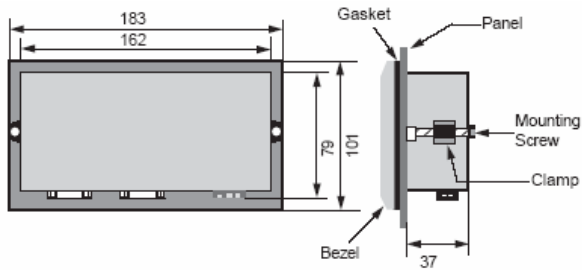

**OIS50**

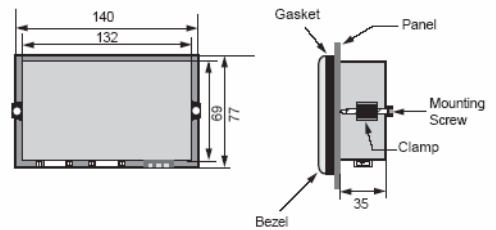

**OIS60**

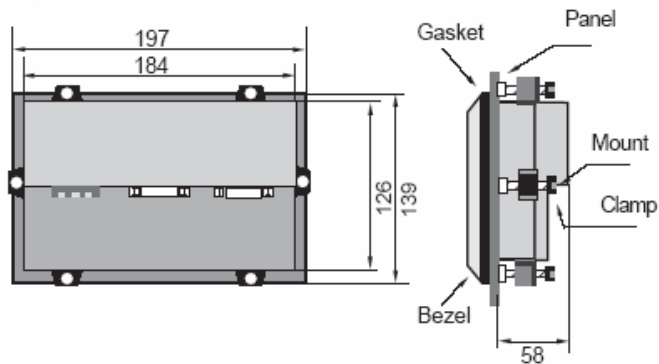

**OIS120**

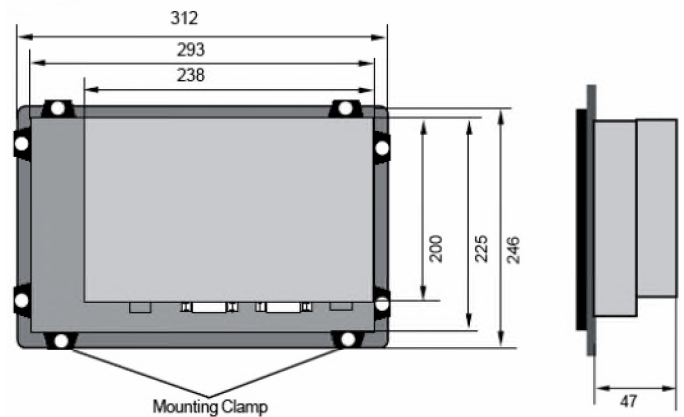

# ORDER INFORMATION

## Operator Interface Stations

Part Number	Description
OIS120	12" SVGA Color Touch Panel, Requires 24 Vdc PS. Requires OISetup32 Software.
OIS60	6" QVGA Color Touch Panel, Requires 24 Vdc PS. Requires OISetup32 Software.
OIS50	4.1" LCD Touch Panel, Requires 24 Vdc PS. Requires OISetup32 Software.
OIS40R	4 Line x 20 Character Display with Keypad, 8 Function Keys, 8 LEDs, Requires 24 Vdc PS. Requires OISetup32 Software.
OIS40	4 Line x 20 Character Display with Keypad, 8 Function Keys, 8 LEDs. Power from PLC. Requires OISetup32 Software.
OIS20	2 Line x 16 Character Display, 6 Function Keys, 2 LEDs. Power from PLC. Requires OISetup Software.
OIS15	4 Line x 16 Character backlit LCD Display, 8 Function Keys, 4 LEDs. No Programming-- Messages & Functions are stored in PLC. Power from PLC. Comes with cable for T1
OIS10	2 Line x 16 Character backlit LCD Display, 6 Function Keys, 2 LEDs. No Programming--Messages & Functions are stored in PLC. Power from PLC. Comes with cable for T1.

Note: Some OIS have two 9 pin D shell female connectors. These are Node 1 & 2 for connecting to devices with different protocols. Either can be used to download an application program.

## Cables

Part Number	Description
IBM-0909-1-00	Cable, Programming, Connects OIS to Computer for downloading application program.
SC-P-019A-00	Cable, Connects OIS40R & all Touchscreens to T1, 9 pin D Shell to 8 pin Mini DIN, 2 m.
SC-P-019B-00	Cable, Connects OIS40R & all Touchscreens to T2E/T2N/T3/S2E/S2T RS232 port, 9 pin D Shell to 9 pin D Shell, 2 m.
SC-P-046A-00	Cable, Connects OIS40R & all Touchscreens to RS485 port, Pigtail on T1/T2/S2E/S2T end, 2 m.
SC-P-046B-00	Cable, Connects OIS40R & all Touchscreens to T2N/T3 RS485 port (DB 15 connector), 2 m
EC-I-019A-00	Cable, Connects new OIS40 to T1 Programming Port, 2 m
EC-I-019B-00	Cable, Connects new OIS40 to T2E/T2N/T3/S2E/S2T Programming Port, 2 m
CAB-OIS-T1-X	Cable, Connects OIS10/15/20/old40 to T1 PLC, comes with OIS10/15
CAB-OIS-T2-X	Cable, Connects OIS10/15/20/old40/ to T2/T3/S2E/S2Tx PLC, Order separately
SC-P-050-00	Cable, Connects OIS40R & all Touchscreens to S11/VF_nC1 port, Smart cable, 2 m.

# OTHER TOSHIBA PRODUCTS

# TOSHIBA

TOSHIBA INTERNATIONAL CORPORATION



**Low Voltage ASDs**



**Medium Voltage ASDs**



**Controls**



**Solid State Starters**



**Low Voltage Motors**



**Operator Interface Stations**



**Low Voltage Motor Controllers**



**Medium Voltage Motors**

**... and Product Solutions**



**Control Systems**



**Instrumentation Products**



**PLCs**



**Uninterruptible Power Systems**

**Power, Control and Protection for Industrial Systems**

**PLCs ADJUSTABLE SPEED DRIVES MOTORS CONTROLS UPS INSTRUMENTATION**

---

**TOSHIBA**

Available Through:

**TOSHIBA INTERNATIONAL CORPORATION**

**INDUSTRIAL DIVISION**

13131 West Little York Road, Houston, Texas 77041

Tel 713/466-0277 Fax 713/466-8773

US 800/231-1412 Canada 800/872-2192 Mexico 01/800/527-1204

[www.toshiba.com/ind](http://www.toshiba.com/ind) [plc@toshiba.com/ind](mailto:plc@toshiba.com/ind)



## Free Manuals Download Website

<http://myh66.com>

<http://usermanuals.us>

<http://www.somanuals.com>

<http://www.4manuals.cc>

<http://www.manual-lib.com>

<http://www.404manual.com>

<http://www.luxmanual.com>

<http://aubethermostatmanual.com>

Golf course search by state

<http://golfingnear.com>

Email search by domain

<http://emailbydomain.com>

Auto manuals search

<http://auto.somanuals.com>

TV manuals search

<http://tv.somanuals.com>