

Toshiba Personal Computer
PORTÉGÉ M500
Maintenance Manual

TOSHIBA CORPORATION

File Number 960-559

[CONFIDENTIAL]

Copyright

© 2006 by Toshiba Corporation. All rights reserved. Under the copyright laws, this manual cannot be reproduced in any form without the prior written permission of Toshiba. No patent liability is assumed with respect to the use of the information contained herein.

Toshiba Personal Computer PORTÉGÉ M500 Maintenance Manual

First edition April 2006

Disclaimer

The information presented in this manual has been reviewed and validated for accuracy. The included set of instructions and descriptions are accurate for the PORTÉGÉ M500 at the time of this manual's production. However, succeeding computers and manuals are subject to change without notice. Therefore, Toshiba assumes no liability for damages incurred directly or indirectly from errors, omissions, or discrepancies between any succeeding product and this manual.

Trademarks

IBM is a registered trademark and IBM PC is a trademark of International Business Machines Corporation.

Intel, Intel SpeedStep, Intel Core, Celeron and Centrino are trademarks or registered trademarks of Intel Corporation or its subsidiaries in the United States and other countries/regions.

Windows and Microsoft are registered trademarks of Microsoft Corporation.

Photo CD is a trademark of Eastman Kodak.

Bluetooth is a trademark owned by its proprietor and used by TOSHIBA under license.

i.LINK is a trademark of Sony Corporation.

Preface

This maintenance manual describes how to perform hardware service maintenance for the Toshiba Personal Computer PORTÉGÉ M500.

The procedures described in this manual are intended to help service technicians isolate faulty Field Replaceable Units (FRUs) and replace them in the field.

SAFETY PRECAUTIONS

Four types of messages are used in this manual to bring important information to your attention. Each of these messages will be italicized and identified as shown below.

DANGER: “Danger” indicates the existence of a hazard that could result in death or serious bodily injury, if the safety instruction is not observed.

WARNING: “Warning” indicates the existence of a hazard that could result in bodily injury, if the safety instruction is not observed.

CAUTION: “Caution” indicates the existence of a hazard that could result in property damage, if the safety instruction is not observed.

NOTE: “Note” contains general information that relates to your safe maintenance service.

Improper repair of the computer may result in safety hazards. Toshiba requires service technicians and authorized dealers or service providers to ensure the following safety precautions are adhered to strictly.

- Be sure to fasten screws securely with the right screwdriver. If a screw is not fully fastened, it could come loose, creating a danger of a short circuit, which could cause overheating, smoke or fire.
- If you replace the battery pack or RTC battery, be sure to use only the same model battery or an equivalent battery recommended by Toshiba. Installation of the wrong battery can cause the battery to explode.

The manual is divided into the following parts:

- Chapter 1 Hardware Overview describes the PORTÉGÉ M500 system unit and each FRU.
- Chapter 2 Troubleshooting Procedures explains how to diagnose and resolve FRU problems.
- Chapter 3 Test and Diagnostics describes how to perform test and diagnostic operations for maintenance service.
- Chapter 4 Replacement Procedures describes the removal and replacement of the FRUs.
- Appendices The appendices describe the following:
 - Handling the LCD module
 - Board layout
 - Pin assignments
 - Keyboard scan/character codes
 - Key layout
 - Wiring diagrams
 - BIOS rewrite procedures
 - EC/KBC rewrite procedures
 - Reliability

Conventions

This manual uses the following formats to describe, identify, and highlight terms and operating procedures.

Acronyms

On the first appearance and whenever necessary for clarification acronyms are enclosed in parentheses following their definition. For example:

Read Only Memory (ROM)

Keys

Keys are used in the text to describe many operations. The key top symbol as it appears on the keyboard is printed in **boldface** type.

Key operation

Some operations require you to simultaneously use two or more keys. We identify such operations by the key top symbols separated by a plus (+) sign. For example, **Ctrl + Pause (Break)** means you must hold down **Ctrl** and at the same time press **Pause (Break)**. If three keys are used, hold down the first two and at the same time press the third.

User input

Text that you are instructed to type in is shown in the boldface type below:

DISKCOPY A: B:

The display

Text generated by the computer that appears on its display is presented in the type face below:

```
Format complete
System transferred
```

Table of Contents

Chapter 1 Hardware Overview

1.1	Features	1-1
1.2	2.5-inch Hard Disk Drive.....	1-12
1.3	Keyboard.....	1-14
1.4	Optical Drive.....	1-15
1.5	TFT Color Display	1-17
1.6	Power Supply	1-19
1.7	Batteries	1-21
1.8	AC Adaptor.....	1-23

Chapter 2 Troubleshooting Procedures

2.1	Troubleshooting	2-1
2.2	Troubleshooting Flowchart.....	2-3
2.3	Power Supply Troubleshooting.....	2-7
2.4	System Board Troubleshooting.....	2-19
2.5	USB FDD Troubleshooting	2-36
2.6	HDD Troubleshooting	2-39
2.7	Keyboard and Touch pad Troubleshooting.....	2-44
2.8	Display Troubleshooting.....	2-47
2.9	Optical Drive Troubleshooting	2-49
2.10	Modem Troubleshooting.....	2-51
2.11	LAN Troubleshooting.....	2-53
2.12	Bluetooth Troubleshooting	2-54
2.13	Wireless LAN Troubleshooting.....	2-56
2.14	Sound Troubleshooting.....	2-58
2.15	Bridge media Slot Troubleshooting	2-61
2.16	Fingerprint sensor Troubleshooting.....	2-62

Chapter 3 Tests and Diagnostics

3.1	The Diagnostic Test	3-1
3.2	Executing the Diagnostic Test	3-4
3.3	Setting of the hardware configuration	3-9
3.4	Heatrun Test.....	3-11
3.5	Subtest Names.....	3-12
3.6	System Test.....	3-14
3.7	Memory Test.....	3-16
3.8	Keyboard Test.....	3-17
3.9	Display Test	3-18
3.10	Floppy Disk Test.....	3-21
3.11	Printer Test.....	3-23
3.12	Async Test	3-25
3.13	Hard Disk Test	3-26
3.14	Real Timer Test.....	3-29
3.15	NDP Test.....	3-31
3.16	Expansion Test.....	3-32
3.17	CD-ROM/DVD-ROM Test	3-34
3.18	Error Code and Error Status Names.....	3-35
3.19	Hard Disk Test Detail Status	3-38
3.20	ONLY ONE TEST.....	3-40
3.21	Head Cleaning.....	3-47
3.22	Log Utilities	3-48
3.23	Running Test.....	3-50
3.24	Floppy Disk Drive Utilities.....	3-51
3.25	System Configuration	3-56
3.26	Wireless LAN Test Program (Atheros)	3-58
3.27	Wireless LAN Test Program (Intel-made a/b/g).....	3-65
3.28	LAN/Modem/Bluetooth/IEEE1394 Test Program	3-69
3.29	Sound Test program.....	3-84
3.30	SETUP	3-90

Chapter 4 Replacement Procedures

4.1	General.....	4-1
4.2	Battery pack	4-8
4.3	PC card.....	4-10
4.4	Bridge media.....	4-11
4.5	HDD	4-12
4.6	Optical drive.....	4-15
4.7	Keyboard.....	4-18
4.8	Memory module.....	4-21
4.9	Cover FAT assembly	4-23
4.10	Fingerprint sensor board	4-28
4.11	Touch pad.....	4-30
4.12	SW membrane.....	4-32
4.13	Bluetooth module.....	4-34
4.14	Wireless LAN card	4-36
4.15	MDC (Modem Daughter Card).....	4-38
4.16	Internal microphone	4-40
4.17	RTC battery	4-42
4.18	Harness holder/LAN cable.....	4-44
4.19	System board/DC-IN jack.....	4-47
4.20	Modem jack/Wireless communication SW.....	4-50
4.21	Fan/CPU.....	4-53
4.22	HDD cable/PC card slot.....	4-57
4.23	LCD unit/FL inverter	4-59
4.24	Speaker/LCD cable	4-65
4.25	Cover latch	4-67
4.26	Wireless LAN antenna/Bluetooth antenna.....	4-68
4.27	Hinge.....	4-70
4.28	Battery slider.....	4-72
4.29	Fluorescent Lamp.....	4-73

Appendices

Appendix A	Handling the LCD Module	A-1
Appendix B	Board Layout	B-1
Appendix C	Pin Assignments.....	C-1
Appendix D	Keyboard Scan/Character Codes	D-1
Appendix E	Key Layout.....	E-1
Appendix F	Wiring Diagrams.....	F-1
Appendix G	BIOS rewrite Procedures	G-1
Appendix H	EC/KBC rewrite Procedures	H-1
Appendix I	Reliability.....	I-1

Chapter 1

Hardware Overview

[CONFIDENTIAL]

Chapter 1 Contents

1.1	Features.....	1-1
1.2	2.5-inch Hard Disk Drive	1-12
1.3	Keyboard	1-14
1.4	Optical Drive	1-15
	1.4.1 DVD-ROM & CD-R/RW Drive	1-15
	1.4.2 DVD-Super Multi Drive	1-16
1.5	TFT Color Display	1-17
	1.5.1 LCD Module	1-17
	1.5.2 FL Inverter Board	1-18
1.6	Power Supply.....	1-19
1.7	Batteries	1-21
	1.7.1 Main Battery	1-21
	1.7.2 RTC battery.....	1-22
1.8	AC Adaptor	1-23

Figures

Figure 1-1	Front of the computer	1-5
Figure 1-2	System unit configuration.....	1-5
Figure 1-3	System unit block diagram	1-6
Figure 1-4	2.5-inch HDD	1-12
Figure 1-5	Keyboard	1-14
Figure 1-6	LCD module	1-17

Tables

Table 1-1	2.5-inch HDD specifications	1-12
Table 1-2	DVD-ROM&CD-R/RW drive specifications.....	1-15
Table 1-3	DVD Super Multi drive specifications	1-16
Table 1-4	LCD module specifications	1-17
Table 1-5	FL inverter board specifications.....	1-18
Table 1-6	Power supply output rating.....	1-20
Table 1-7	Battery specifications	1-21
Table 1-8	Time required for charges	1-21
Table 1-9	Data preservation time.....	1-22
Table 1-10	RTC battery charging/data preservation time.....	1-22
Table 1-11	AC adapter specifications.....	1-23

1.1 Features

The Toshiba PORTÉGÉ M500 Personal Computer uses advanced Large Scale Integration (LSI), and Complementary Metal-Oxide Semiconductor (CMOS) technology extensively to provide compact size, minimum weight, low power usage and high reliability. This computer incorporates the following features.

There some models and options according to BTO system. Refer to the Parts List for the configuration of each model and options.

Microprocessor

The PORTÉGÉ M500 computer is equipped with one of the following processors.

Intel® Core™ Duo

Core™ Duo	1.66GHz (Processor Number : T2300)
	1.83GHz (Processor Number : T2400)
	2.00GHz (Processor Number : T2500)
	2.16GHz (Processor Number : T2600)
	2.33GHz (Processor Number : T2700)

Intel® Core™ Solo

Core™ Solo	1.66GHz (Processor Number : T1300)
	1.83GHz (Processor Number : T1400)

Intel® Celeron® M

Celeron® M	1.46GHz (Processor Number : 410)
	1.60GHz (Processor Number : 420)
	1.73GHz (Processor Number : 430)

Chipset

Equipped with Intel 945GM/940GML as North Bridge, Intel ICH7-M as South Bridge and Texas Instrument PCI7412 as Card Controller.

VGA Controller

An internal Graphics Controller in North Bridge is used.

Memory

Two DDR2-533/DDR2-667 SDRAM slots. Memory modules can be installed to provide a maximum of 4GB (Intel 945GM) or 2GB (Intel 940GML). Memory modules are available in 256MB, 512MB, 1024MB and 2048MB sizes.

 HDD

The computer has a 2.5-inch SATA HDD. The following capacities are available.

- 40/60/80/100/120 GB

 USB FDD

A 3.5-inch USB FDD accommodates 2HD (1.44MB) or 2DD (720KB) disks.

 Optical Drive

DVD-ROM&CD-R/RW drive or DVD Super Multi drive (double layer) can be installed.

 Display

LCD : Built-in 12.1 inch, 16M colors, WXGA (1280×800dots), thin type low temperature poly-silicon TFT color display.

External monitor : Supported via an RGB connector.

 Keyboard

An-easy-to-use 84(US)/85(UK)-key keyboard provides a numeric keypad overlay for fast numeric data entry or for cursor and page control. The keyboard also includes two keys that have special functions in Microsoft® Windows® 2000/XP. It supports software that uses a 101- or 102-key enhanced keyboard.

 Touch pad

A Touch Pad and control buttons in the palm rest enable control of the on-screen pointer and scrolling of windows.

 Batteries

The computer has two batteries: a rechargeable Lithium-Ion main battery pack and RTC battery (that backs up the Real Time Clock and CMOS memory).

Universal Serial Bus (USB2.0)

Three USB ports are provided. The ports comply with the USB2.0 standard.

 IEEE 1394 port

The computer comes with one IEEE 1394 port. It enables high-speed data transfer directly from external devices such as digital video cameras.

 External monitor (RGB) port

The port enables connection of an external monitor, which is recognized automatically by Video Electronics Standards Association (VESA) Display Data Channel (DDC) 2B compatible functions.

 PC card slot

A PC card slot is provided. The PC card slot (PCMCIA) accommodates one Type II card.

 Bridge media slot

This supports one SD memory card/SDIO card/Memory stick/Memory stick PRO/xD picture card/MultiMediaCard slot. Data can be read and written by inserting each media to the slot.

 Fingerprint sensor

The computer is equipped with a fingerprint sensor and fingerprint authentication utility. They enable only person who has registered his/her fingerprint to use the computer.

 Sound system

The sound system is equipped with the following features:

- Stereo speakers
- Built-in microphone
- Volume control
- Stereo headphone jack
- External microphone jack

Internal modem

The computer contains a MDC, enabling data and fax communication. It supports ITU-T V.90 (V.92). The transfer rates are 56 Kbps for data reception, 33.6 Kbps for data transmission, and 14,400 bps for fax transmission. However, the actual speed depends on the line quality. The RJ11 modem jack is used to accommodate a telephone line. Both of V.90 and V.92 are supported only in USA, Canada and Australia. Only V.90 is available in other regions.

 Internal LAN

The computer has built-in support for Ethernet LAN (10 megabits per second, 10BASE-T), Fast Ethernet LAN (100 megabits per second, 100BASE-TX) and Gigabit Ethernet LAN (1000 megabits per second, 1000BASE-T). It also supports Wakeup on LAN (WOL), Magic Packet and LED. Some models are not equipped with a Gigabit Ethernet LAN.

 Wireless LAN

The computer is equipped with PCI Express Mini Card type wireless LAN card that supports 802.11 b/g or 802.11 a/b/g in the PCI Express MiniCard slot. This function can be switched on and off by a switch on the computer.

 Bluetooth

The computer is equipped with Bluetooth (V2.0+EDR) communications standard enable wireless connection between electronic devices such as computers and printers. It supports wireless communication switch.

 Presentation button

This button switches the display between internal display, external display, simultaneous display and multi-monitor display.

 TOSHIBA Assist button

When this button is pressed during power-on, the PC is connected to “Toshiba Assist”. When this button is pressed during power-off, the PC is turned on and connected to “Toshiba Assist”.

The front of the computer is shown in figure 1-1.

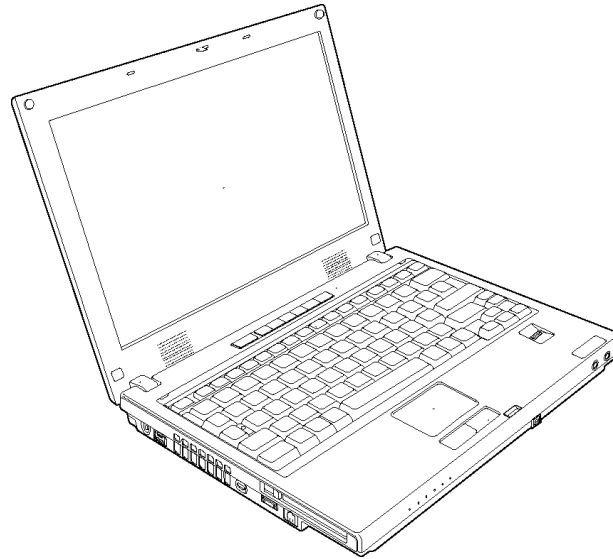

Figure 1-1 Front of the computer

The system unit configuration is shown in figure 1-2.

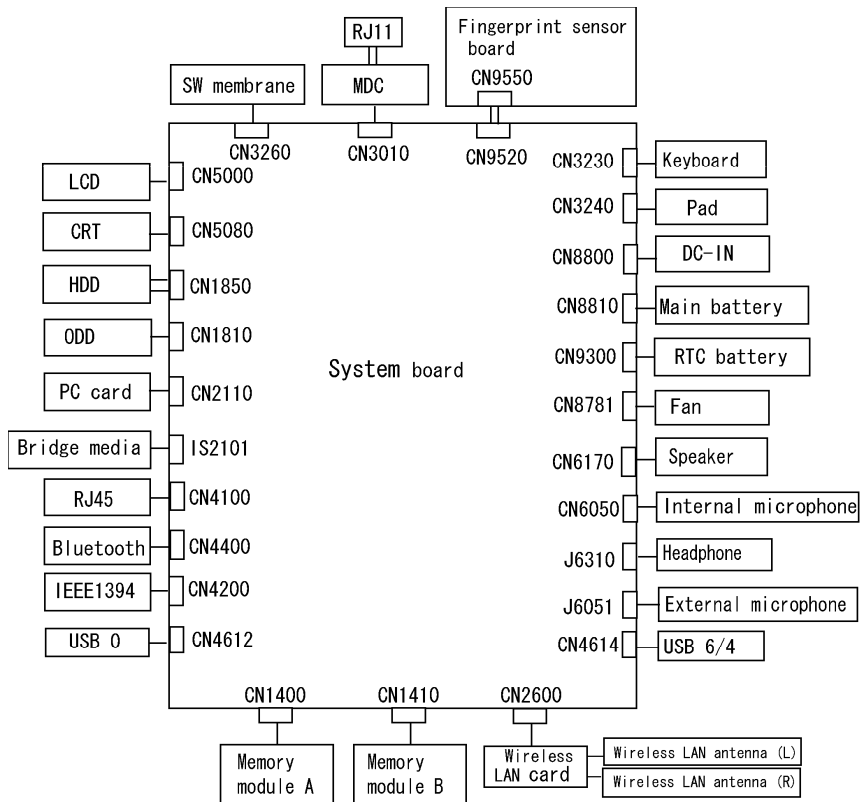

Figure 1-2 System unit configuration

System Unit Block Diagram

Figure 1-3 is a block diagram of the system unit.

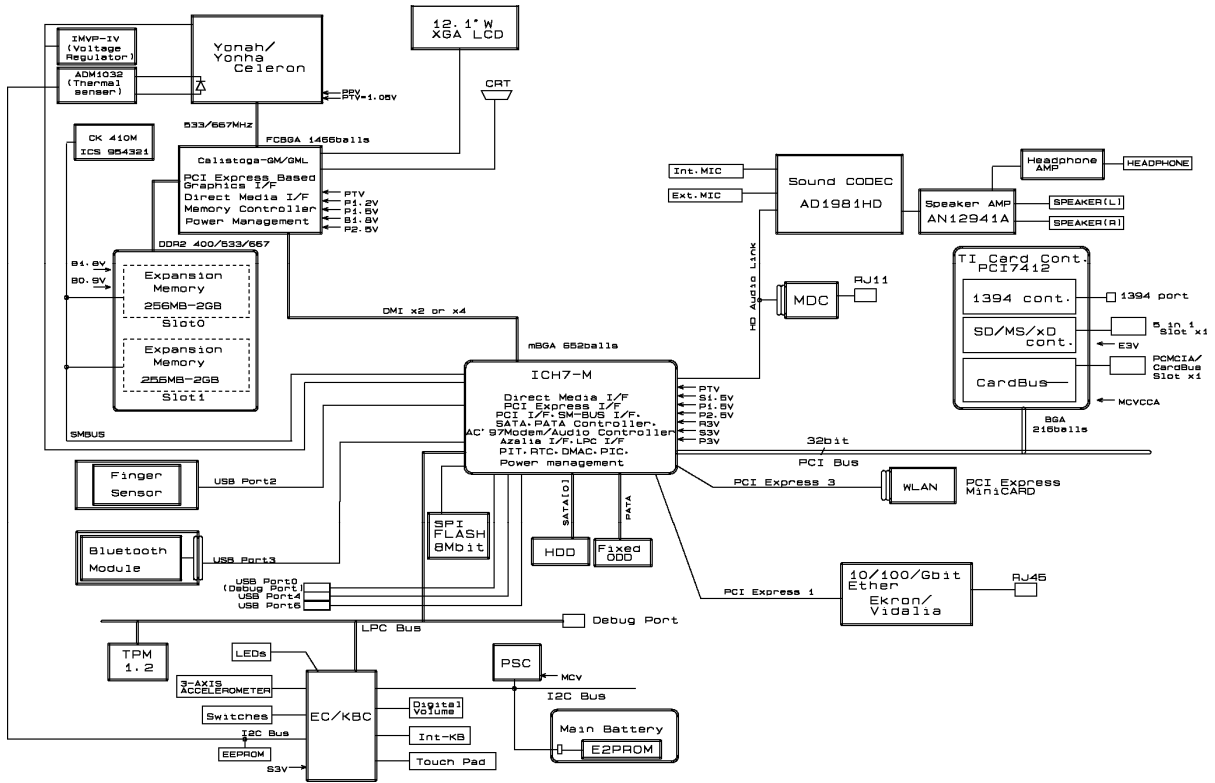

Figure 1-3 System unit block diagram

The system unit is composed of the following major components:

❑ Processor

Intel® Core™ Duo Processor (dual core) or Intel® Core™ Solo Processor (single core)

- Core speed:

Dual core: 1.66GHz (T2300) /1.83GHz (T2400)/2.00GHz (T2500)/
2.16GHz (T2600)/2.33GHz (T2700)

Single core 1.66GHz (T1300)/1.83GHz (T1400)

(): Processor Number

- Processor bus speed: 667MHz
- Core voltage: 0.50 to 1.30V
- Integrated L1 cache memory of 64KB (32KB +32KB)
- Integrated L2 cache memory of 2MB
- Integrated NDP
- 478-pin Micro FC-PGA package

Intel® Celeron® M Processor

- Core speed:

1.46GHz (410)/1.60GHz (420)/1.72GHz (430)

(): Processor Number

- Processor bus speed: 533MHz
- Core voltage: 1.00 to 1.30V
- Integrated L1 cache memory of 64KB (32KB +32KB)
- Integrated L2 cache memory of 1MB
- Integrated NDP
- 478-pin Micro FC-PGA package

❑ Memory

Two memory slots capable of accepting DDR2-SDRAM 256MB, 512MB, 1024MB or 2048MB memory modules for a maximum of 4GB (Intel 945GM) or 2GB (Intel 940GML).

- 200-pin Small Outline DIMM
- 1.8V operation
- PC2-4200(DDR2-533)/PC2-5300(DDR2-667) support

❑ Serial Peripheral Interface (SPI)

- One STMicro M25PE80-VMW6TG is used.
- 8Mbits of flash memory are used.
 - 320KB for System BIOS
 - 64KB for VGA BIOS
 - 64KB for Finger Print PBA
 - 128KB for LAN BIOS
 - 24KB for Boot
 - 16KB for Parameter Block
 - 32KB for Option Log
 - Others

❑ North Bridge

- One Intel 945GM/940GML is used.
- Features:
 - Supports Yonah Processor System Bus
 - Supports System Memory : DDR2-400/DDR2-533/DDR2-667, 4GB (Intel 945GM) (max) or 2GB (Intel 940GML) (max)
 - Internal Graphics Controller : Inter Generation 3.5 Integrated GFX Core (250MHz)
 - DMI(Direct Media Interface)
 - Supports ICH.
 - 1466-ball 37.5×37.5×2.56mm FC-BGA package

❑ South Bridge (Intel ICH7-M)

- Features:
 - DMI(Direct Media Interface)
 - PCI Express I/F (4 ports)
 - PCI Bus I/F Rev2.3 (6 PCI REQ/GNT Pairs)
 - Integrated Serial ATA Host Controller (2 Prots,150MB/S)
 - Integrated IDE Controller (Ultra ATA 100/66/33)
 - AC'97 2.3 codecs
 - Intel High Definition controller (Azalia)
 - USB 1.1/2.0 Controller 8 ports
 - Built-in LAN controller (WfM 2.0 & IEEE 802.3 compliance)
 - Power Management (ACPI 2.0 compliance)
 - SMBus2.0 controller
 - Low Pin Count (LPC) interface (EC/KBC, Super I/O)
 - IRQ controller
 - Serial Interrupt Function
 - Suspend/Resume control
 - Built –in RTC
 - GPIO
 - 652-ball 31×31×2.51mm BGA Package

❑ PC Card Controller (TI PCI7412)

- PCI I/F
- CardBus / Ultra media Controller (1 socket)
- SD/MMC, Memory Stick, XD Card Controller
- 1394 Controller (2 ports)
- 288-ball, 16×16×1.4mm, BGA Package

❑ GPU

Graphics interface in North Bridge (Intel 945GM/940GML) is used.

- PCI Express Interface
- LCD Interface LVDS 2ch, Supports UXGA (1600×1200)
- Analog CRT : 400MHz RAMDAC, QXGA (2048×1536) monitor
- Does not support DVI

❑ Sound Controller

- Azalia Link (Intel High Definition Audio I/F) built in the South Bridge (ICH7-M) + ADI AD1981HD
 - Stereo speakers
 - Built-in microphone
 - Volume control
 - Stereo headphone jack
 - External microphone jack

❑ Modem Controller

- Askey/FOXCONN-made one MDC is used.
- This controller has the following functions:
 - One RJ11 port
 - V.92 (V.90) 56K Modem/FAX
 - Supports Ring Wakeup

Internal LAN Controller

- Intel made Ethernet LAN (10 megabits per second, 10BASE-T), Fast Ethernet LAN (100 megabits per second, 100BASE-TX) or Gigabit Ethernet LAN (1000 megabits per second, 1000BASE-T) is used. Some models are not equipped with a Gigabit Ethernet LAN.
- This controller has the following functions:
 - PCI-Ex connection
 - Supports Gigabit Ethernet
 - Supports Fast Ethernet
 - One RJ45 port
 - Supports WOL
 - Supports Magic Packet
 - Supports LED
 - Makes LAN to “Disable” in BIOS

 Wireless LAN

- One Mini PCI Express Card slot
 - Supports 802.11b/g or 802.11a/b/g
 - Supports Communication SW
 - Supports W-LAN via PCMCIA (Euro : GSM/GPRS)
 - Does not support WOL

 Other main system chips

- Clock Generator (ICS-made 954321AGLFT)
- EC/KBC (Renesas-made M306KAFCLRP U0)
- PSC (Toshiba-made TMP86FS49UG)
- Temperature sensor (ADM-made 1032ARMZ ×2)
- Acceleration sensor (ST Micro-made LIS3L02AQ3)
- TPM (Infineon-made SLB9635 TT 1.2)

1.2 2.5-inch Hard Disk Drive

The removable HDD is a random access non-volatile storage device. It has a non-removable 2.5-inch magnetic disk and mini-Winchester type magnetic heads.

The computer supports a 40GB, 60GB, 80GB, 100GB or 120GB.

The HDD is shown in figure 1-4. Specifications are listed in Table 1-1.

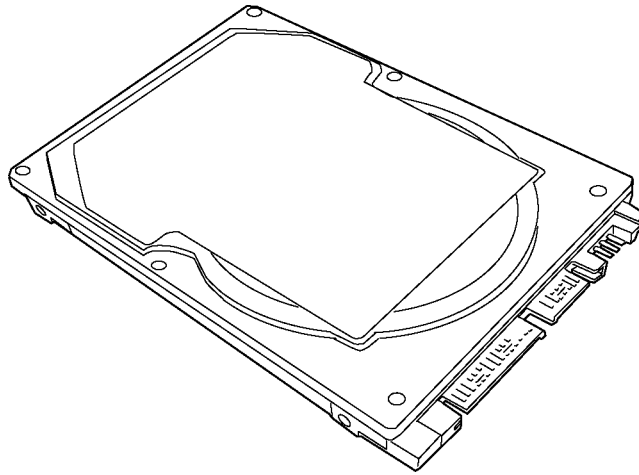

Figure 1-4 2.5-inch HDD

Table 1-1 2.5-inch HDD specifications (1/2)

Items		Specifications			
		TOSHIBA HDD2D34BZK01	TOSHIBA HDD2D35BZK01	TOSHIBA HDD2D32BZK01	TOSHIBA HDD2D30BZK01
Outline dimensions	Width (mm)	69.85±0.25			
	Height (mm)	9.5±0.2			
	Depth (mm)	100±0.41			
	Weight (g)	98 max.		102 max.	
Storage size (formatted)		40GB	60GB	80GB	100GB
Speed (RPM)		5,400			
Data transfer rate (Mb/s)		218-429	244.7-474.7	218-429	236.1-456.0
Data buffer size (KB)		8,192			16,384
Average seek time (ms) Read		12			
Motor startup time (s)		4 typ.	3.5 typ.	4 typ.	

Table 1-1 2.5-inch HDD specifications (2/2)

Items		Specifications			
		HITACHI GST G8BC00029411	HITACHI GST G8BC00029611	HITACHI GST G8BC00029811	HITACHI GST G8BC00029A11
Outline dimensions	Width (mm)	69.85±0.25			
	Height (mm)	9.5±0.2			
	Depth (mm)	100.2±0.25			
	Weight (g)	95 max.	102 max.		
Storage size (formatted)		40GB	60GB	80GB	100GB
Speed (RPM)		5,400			
Data transfer rate To/From media To/From host		493 Mb/s max. 1.5Gbps			
Data buffer size (MB)		8			
Average seek time (ms) Read		12			
Motor startup time (s)		3.5 typ.			

Items		Specifications	
		TOSHIBA HDD2D31BZK01	HITACHI GST G8BC0002NA10
Outline dimensions	Width (mm)	69.85±0.25	69.85±0.25
	Height (mm)	9.5±0.2	9.5±0.2
	Depth (mm)	100±0.41	100.2±0.25
	Weight (g)	102 max.	115 max.
Storage size (formatted)		120GB	100GB
Speed (RPM)		5,400	7,200
Data transfer rate To/From media (Mb/s) To/From host (Gbps)		244.7-474.7 -	629 max. 1.5
Data buffer size (KB)		8,192	8,192
Average seek time (ms) Read		12	10 typ.
Motor startup time (s)		3.5 typ.	4 typ.

1.3 Keyboard

The keyboard is mounted 84(US)/85(UK) keys that consist of character key and control key. The keyboard is connected to membrane connector on the system board and controlled by the keyboard controller.

Figure 1-5 is a view of the keyboard.

See Appendix E about a layout of the keyboard.



Figure 1-5 Keyboard

1.4 Optical Drive

1.4.1 DVD-ROM & CD-R/RW Drive

The DVD-ROM & CD-R/RW drive accommodates either 12 cm (4.72-inch) or 8 cm (3.15-inch) CD-ROM, DVD-ROM and CD-R/RW.

The specifications of the DVD-ROM & CD-R/RW drive are described in Table 1-2.

Table 1-2 DVD-ROM & CD-R/RW drive specifications

Item		Specifications
		MATSUSHITA G8CC00025A20
Outline dimensions	Width (mm)	128 (excluding projections)
	Height (mm)	9.5 (excluding projections)
	Depth (mm)	129 (excluding projections)
	Mass (g)	141±3
Data transfer speed (Read) DVD-ROM CD-ROM		Max. 8x CAV Max. 24x CAV
Data transfer speed (Write) CD-R CD-RW High Speed CD-RW Ultra Speed CD-RW		Max. 24x CAV Max. 4x CLV Max. 10x CLV Max. 24x CAV
ATAPI Burst (MB/s) PIO Mode DMA Mode Ultra DMA Mode		16.6 (PIO MODE4) 16.6 (Multi Word Mode2) 33.3 (Ultra DMA Mode2)
Data Buffer Capacity		2MB
Access time (ms) CD-ROM DVD-ROM		150 typ. (Random) 170 typ. (Random)
Supported Disks		CD: CD/CD-ROM (12cm, 8cm), CD-R, CD-RW DVD: DVD-ROM, DVD-R, DVD-RW, DVD-RAM, DVD-R DL, DVD+RW, DVD+RAM, DVD+R DL
Supported Formats		CD: CD-DA, CD-ROM, CD-ROM XA, PHOTO CD, CD-Extra(CD+), CD-text DVD: DVD-R, DVD-RW (Ver.1.2), DVD-Video, DVD+R, DVD+RW, DVD-RAM (2.6GB/4.7GB)

1.4.2 DVD-Super Multi Drive

The DVD Super Multi drive accommodates either 12 cm (4.72-inch) or 8 cm (3.15-inch) CD-ROM, DVD-ROM, CD-R, CD-RW, DVD-R, DVD+R, DVD-RW, DVD+RW, DVD-RAM, DVD-R DL and DVD+R DL.

The specifications are listed in Table 1-3.

Table 1-3 DVD Super Multi drive specifications

Item		Specifications
		MATSUSHITA G8CC00030120
Outline dimensions	Width (mm)	128 (excluding projections)
	Height (mm)	9.5 (excluding projections)
	Depth (mm)	129 (excluding projections)
	Mass (g)	140±5
Data transfer speed (Read) DVD-ROM CD-ROM		Max. 8x CAV Max. 24x CAV
Data transfer speed (Write) CD-R CD-RW High Speed CD-RW Ultra Speed CD-RW DVD-R DVD-R DL DVD-RW DVD+R DVD+R DL DVD+RW DVD-RAM		Max. 24x ZCLV Max. 4x CLV Max. 10x CLV Max. 16x CLV Max. 8x ZCLV Max. 2x CLV Max. 4x ZCLV Max. 8x ZCLV Max. 2.4x CLV Max. 4x ZCLV Max. 2-3x ZCLV (4.7GB)
ATAPI Burst (MB/s) PIO Mode DMA Mode Ultra DMA Mode		16.6 (PIO MODE4) 16.6 (Multi Word Mode2) 33.3 (Ultra DMA Mode2)
Data Buffer Capacity		2MB
Access time (ms) CD-ROM DVD-ROM		150Msec typ. 180msec typ.
Supported Disks		CD: CD/CD-ROM (12cm, 8cm), CD-R, CD-RW DVD: DVD-ROM, DVD-R, DVD-RW, DVD-RAM, DVD-R DL, DVD+RW, DVD+RAM, DVD+R DL
Supported Formats		CD: CD-DA, CD-ROM, CD-ROM XA, Photo CD (multi-Session), Video CD, CD-Extra (CD+), CD-text DVD: DVD-VIDEO, DVD-ROM, DVD-R (3.9GB, 4.7GB), DVD-R DL, DVD-RW (Ver.1.1, Ver.1.2), DVD-RAM, DVD+R, DVD+R DL, DVD+RW

1.5 TFT Color Display

The TFT color display consists of 12.1-inch WXGA LCD module and FL inverter board.

1.5.1 LCD Module

The LCD module used for the TFT color display uses a backlight as the light source and can display a maximum of 16M colors with 1,200 x 800 resolution. The GPU in North Bridge can control internal and external WXGA support displays simultaneously.

Figure 1-6 shows a view of the LCD module and Table 1-4 lists the specifications.

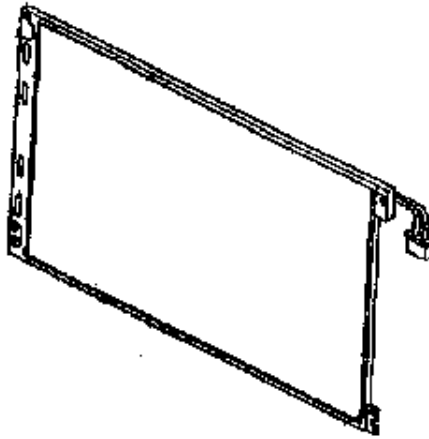

Figure 1-6 LCD module

Table 1-4 LCD module specifications

Item	Specifications
	12.1-inch WXGA TFT (TMD G33C0003C110)
Number of Dots	1,280(W) x 800(H)
Dot spacing (mm)	0.204(H) x 0.204(V)
Display range (mm)	275.8(H) x 178.0(V)

Item	Specifications
	12.1-inch WXGA TFT (SAMSUNG G33C0003K110)
Number of Dots	1,280(W) x 800(H)
Dot spacing (mm)	0.204(H) x 0.204(V)
Display range (mm)	275.8(H) x 178.0(V)

1.5.2 FL Inverter Board

The FL inverter board supplies a high frequency current to illuminate the LCD module.

Table 1-5 lists the FL inverter board specifications.

Table 1-5 FL inverter board specifications

Item		Specifications
		G71C00011221
Input	Voltage (VDC)	5
	Power (W)	7
Output	Voltage (Vrms)	750
	Current (mArms)	6.00
	Power (W/VA)	5/7

1.6 Power Supply

The power supply supplies many different voltages to the system board and performs the following functions:

1. Judges that the DC power supply (AC adapter) is connected to the computer.
2. Detects DC output and circuit malfunctions.
3. Controls the display of battery icon and DC IN icon.
4. Turns the battery charging system on and off and detects a fully charged battery.
5. Turns the power supply on and off.
6. Provides the detection of a low battery.
7. Calculates the remaining battery capacity.
8. Controls the transmission of the status signal of the main battery.

The power supply output rating is specified in Table 1-6.

Table 1-6 Power supply output rating

Name	Power supply				
	Voltage [V]	Power OFF (Suspend mode)	Power OFF (Boot mode)	No battery	Object
PPV	1.500 - 0.300	No	No	No	CPU
PTV	1.05	No	No	No	CPU, GMCH, ICH7-M
1R5-P1V	1.5	No	No	No	CPU, GMCH, ICH7-M, PCI-e Mini Card
1R8-B1V	1.8	Yes	No	No	GMCH, DDR2-SDRAM
2R5-P2V	2.5	No	No	No	GMCH, ICH7-M
LAN2R5-E2V	2.5	Yes	Yes / No	No	LAN
MR0R9-B0V	0.9	Yes	No	No	GMCH, DDR2-SDRAM
0R9-P0V	0.9	No	No	No	DDR2-SDRAM
P3V	3.3	No	No	No	Clock Generator, Thermal Sensor, GMCH, SDRAM(SPD), ICH7-M, HDD, PC-Card Cont., PC-Card Power, PCI-e Mini Card (WLAN), FWH, LED, TPM, LCD, AD1981HD
E3V	3.3	Yes	Yes / No	No	ICH7-M, PCI-e Mini Card (WLAN), MDC, Serial Flash, Finger Sensor
S3V	3.3	Yes	Yes	No	EC/KBC
FM-P3V	3.3	No	No	No	Flash Media
BT-P3V	3.3	No	No	No	Bluetooth
LAN-E3V	3.3	Yes	Yes / No	No	LAN
LAN1R2-E1V	1.2	Yes	Yes / No	No	LAN
P5V	5	No	No	No	ICH7-M, ODD, HDD, PC-Card Power, LED, KB, PAD, CRT, FAN, FL-Inv
E5V	5	Yes	Yes / No	No	ICH7-M, USB Power
M5V	5	Yes	Yes	No	LED
MCV	5	Yes	Yes	No	PSC
SND-P5V	5	No	No	No	AN12941A
A4R7-P4V	4.7	No	No	No	AD1981HD, AN12941A
R3V	2.0 -3.5	Yes	Yes	Yes	ICH7-M (RTC)

1.7 Batteries

The computer has two types of batteries as follows:

- Main battery
- Real Time Clock (RTC) battery

The battery specifications are listed in Table 1-7.

Table 1-7 Battery specifications

Battery name		Material	Output voltage	Capacity
Main battery	G71C0004G710 G71C0004G810	Li-Ion	10.8 V	4,700 mAh
RTC battery	GDM710000041	Ni-MH	2.4 V	15 mAh

1.7.1 Main Battery

The removable main battery pack is the computer's main power source when the AC adaptor is not attached. The main battery maintains the state of the computer when the computer enters in resume mode.

- Battery Charge

When the AC adapter is connected, normal charging is used while the system is turned on and quick charge is used while the system is turned off. Table 1-8 lists the charging time required for charges.

Table 1-8 Time required for charges

Battery type	Power on (hours)	Power off (hours)
Main battery (4,700 mAh)	About 5.5 to 12.0	About 3.0

Charge is stopped in the following cases.

1. The main battery is fully charged.
2. The main battery is removed.
3. Main battery or AC adapter voltage is abnormal.
4. Charging current is abnormal.

❑ Data preservation time

When turning off the power in being charged fully, the preservation time is as following Table 1-9.

Table 1-9 Data preservation time

Battery type	Standby mode	Boot mode
Main battery (4,700 mAh)	6 days	60 days

1.7.2 RTC battery

The RTC battery provides power to keep the current date, time and other setup information in memory while the computer is turned off. Table 1-10 lists the charging time and data preservation period of the RTC battery.

Table 1-10 RTC battery charging/data preservation time

Status	Time
Charging Time (power on)	8 hours
Data preservation period (full charge)	30 days

1.8 AC Adapter

The AC adapter is used to charge the battery.

Table 1-11 lists the AC adapter specifications.

Table 1-11 AC adapter specifications

Parameter	Specification	
	G71C0002SC10	G71C0004A510
Power	60W (Peak 75W)	
Input voltage	100V/240V	
Input frequency	50Hz to 60Hz	
Input current	1.5A or less (100V-240V 4Aload)	
Output voltage	15V	
Output current	0A to 4A (At constant voltage mode)	

Parameter	Specification	
	G71C00043310	G71C00049510
Power	75W (Peak 90W)	
Input voltage	100V/240V	
Input frequency	50Hz to 60Hz	
Input current	1.5A or less (100V-240V)	
Output voltage	15V	
Output current	0A to 5A (At constant voltage mode) 5A to 6A (At surge load mode)	

Chapter 2

Troubleshooting Procedures

[CONFIDENTIAL]

Chapter 2 Contents

2.1	Troubleshooting.....	2-1
2.2	Troubleshooting Flowchart	2-3
2.3	Power Supply Troubleshooting	2-7
2.4	System Board Troubleshooting	2-19
2.5	USB FDD Troubleshooting	2-36
2.6	HDD Troubleshooting	2-39
2.7	Keyboard and Touch pad Troubleshooting	2-44
2.8	Display Troubleshooting	2-47
2.9	Optical Drive Troubleshooting.....	2-49
2.10	Modem Troubleshooting	2-51
2.11	LAN Troubleshooting	2-53
2.12	Bluetooth Troubleshooting.....	2-54
2.13	Wireless LAN Troubleshooting	2-56
2.14	Sound Troubleshooting	2-58
2.15	Bridge media Slot Troubleshooting.....	2-61
2.16	Fingerprint sensor Troubleshooting	2-62

Figures

Figure 2-1 Troubleshooting flowchart2-4
Figure 2-2 A set of tool for debug port test.....2-22

Tables

Table 2-1 Battery icon.....2-7
Table 2-2 DC IN icon.....2-8
Table 2-3 Error code2-10
Table 2-4 Debug port (Boot mode) error status.....2-23
Table 2-5 FDD error code and status2-37
Table 2-6 HDD error code and status2-42

2.1 Troubleshooting

Chapter 2 describes how to determine if a Field Replaceable Unit (FRU) in the computer is causing the computer to malfunction. The FRUs covered are:

- | | | |
|--------------------------|------------------|------------------------|
| 1. Power Supply | 6. Display | 11. Wireless LAN |
| 2. System Board | 7. Optical Drive | 12. Sound components |
| 3. USB Floppy Disk Drive | 8. Modem | 13. Bridge media Slot |
| 4. Hard Disk Drive | 9. LAN | 14. Fingerprint sensor |
| 5. Keyboard/Touch pad | 10. Bluetooth | |

The Test Program operations are described in Chapter 3. Detailed replacement procedures are described in Chapter 4.

NOTE: Before replacing the system board, it is necessary to execute the subtest 03 DMI Information save of the 3.3 Setting of the hardware configuration in Chapter 3.

After replacing the system board, it is necessary to execute the subtest 04 DMI Information recovery and subtest 08 System configuration display of the 3.3 Setting of the hardware configuration in Chapter 3.

Also update with the latest EC/KBC as described in Appendix H “EC/KBC Rewrite Procedures”.

The implement for the Diagnostics procedures is referred to Chapter 3. Also, following implements are necessary:

1. Phillips screwdrivers (For replacement procedures, Refer to Chapter 4)
2. Implements for debugging port check
 - Toshiba MS-DOS system FD
 - RS-232C cross cable
 - Test board with debug port test cable
 - PC for displaying debug port test result

There are following two types of connections in the figure of board and module connection in and after 2.3 Power Supply Troubleshooting.

(1) Cable connection is described in the figure as line.

(2) Pin connection is described in the figure as arrow.

<e.g> Connection of modem

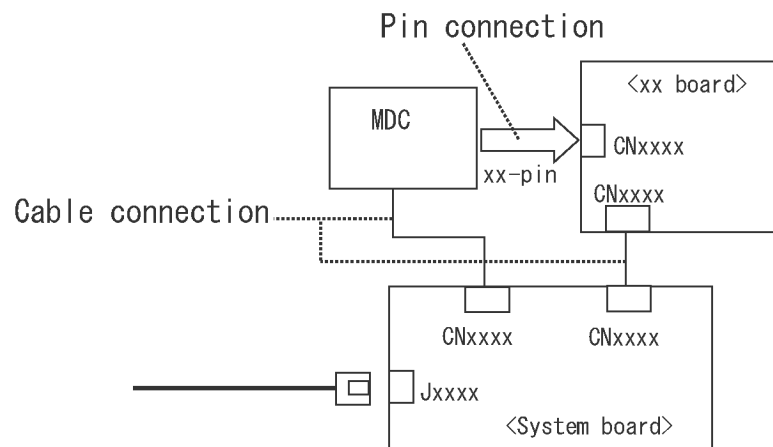

2.2 Troubleshooting Flowchart

Use the flowchart in Figure 2-1 as a guide for determining which FRU malfunctions. Before going through the flowchart steps, check the following:

- Ask the user if a password is registered and, if it is, ask him or her to enter the password.
- Make sure that Windows[®] XP preinstalled by Toshiba is installed on the hard disk. Operating systems not preinstalled by Toshiba can cause the computer malfunction.
- Make sure all optional equipment is removed from the computer.
- Make sure the USB FDD and optical drive are empty.

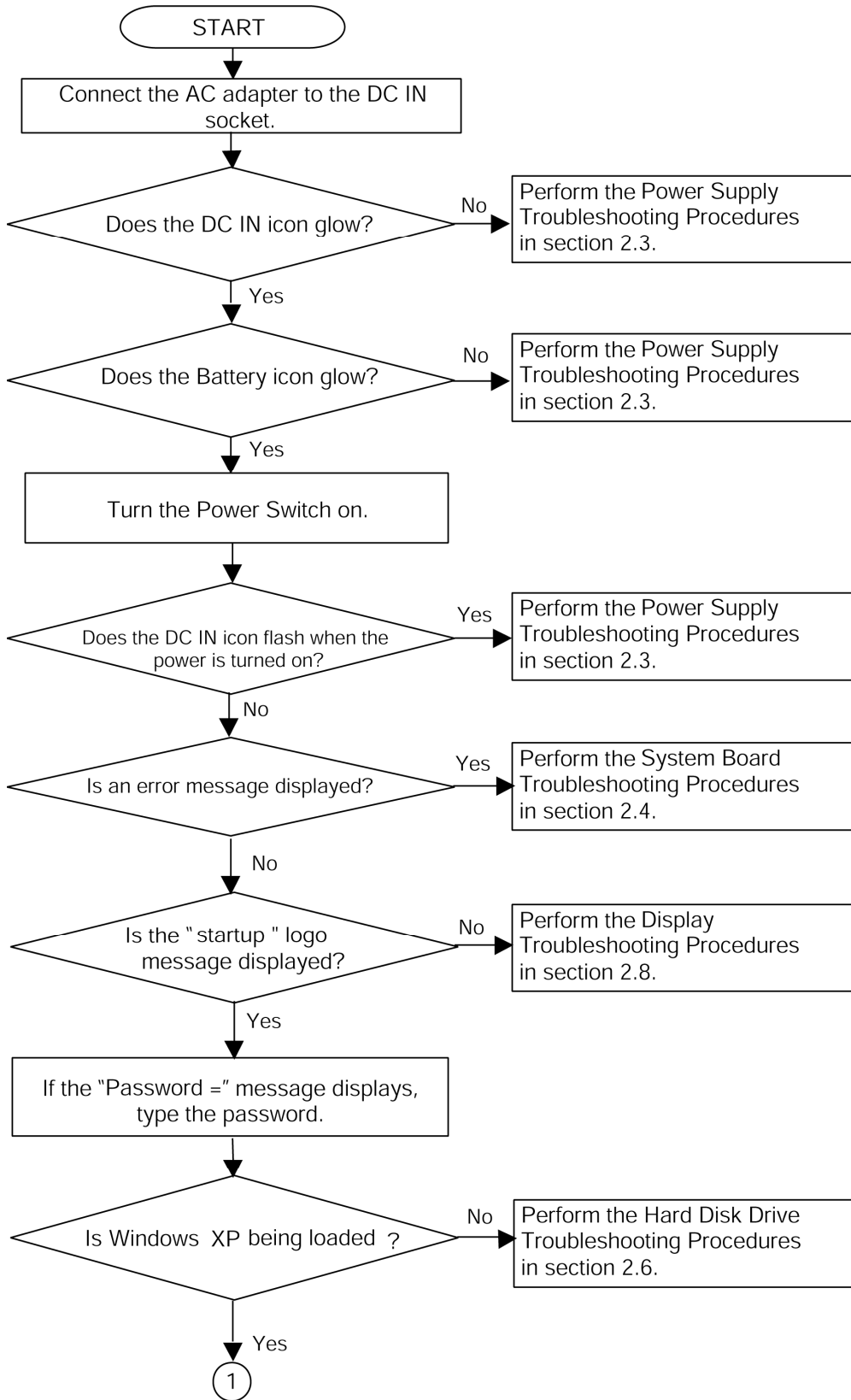

Figure 2-1 Troubleshooting flowchart (1/2)

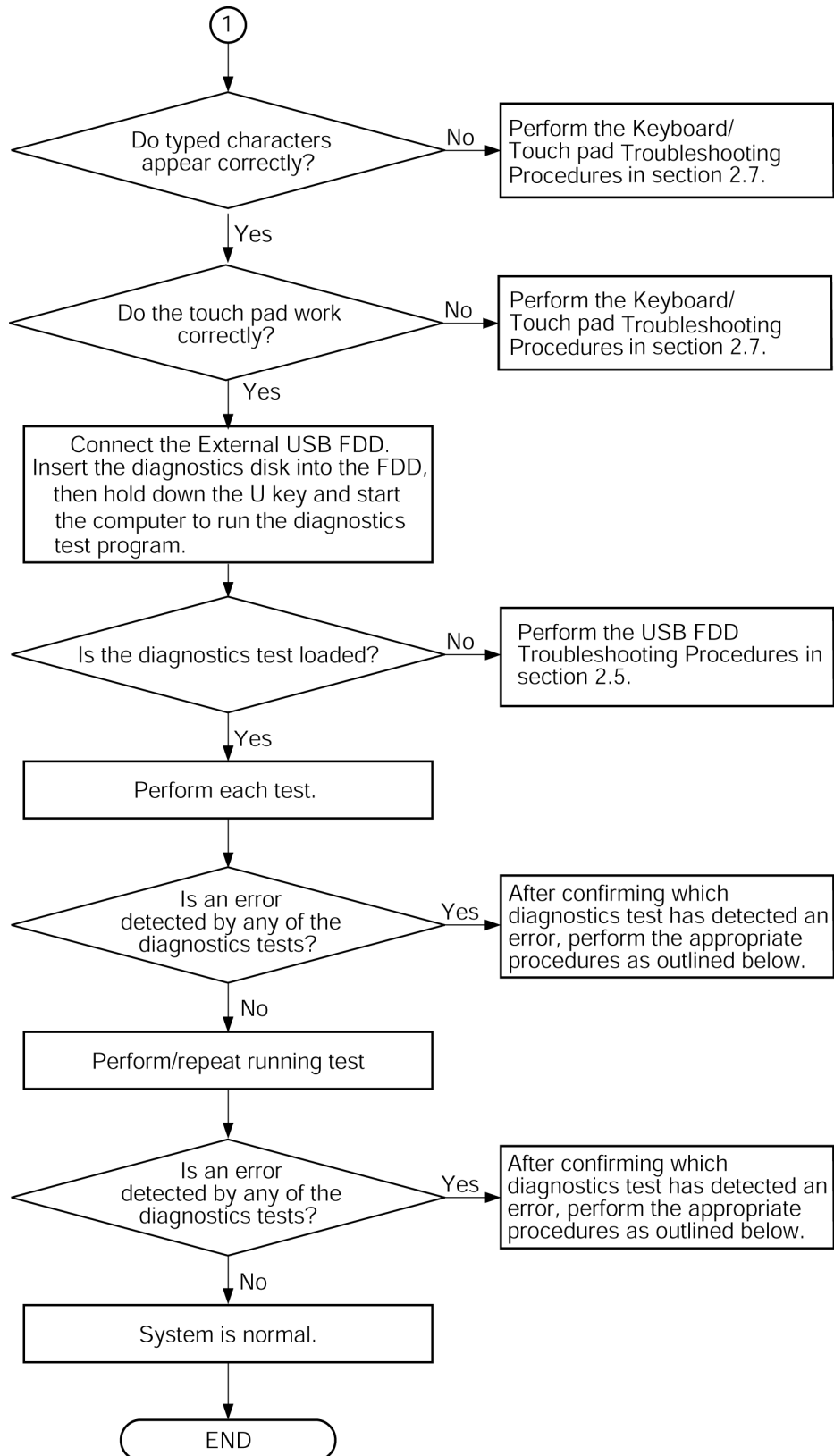

Figure 2-1 Troubleshooting flowchart (2/2)

If the diagnostics program cannot detect an error, the problem may be intermittent. The Running Test program should be executed several times to isolate the problem. Check the Log Utilities function to confirm which diagnostic test detected an error, then perform the appropriate troubleshooting procedures as follows:

1. If an error is detected on the system test, memory test, display test, CD-ROM/DVD-ROM test, expansion test, real timer test, Sound/LAN/Modem test, Bluetooth test or IEEE1394 test, perform the System Board Troubleshooting Procedures in Section 2.4.
2. If an error is detected on the floppy disk test, perform the USB FDD Troubleshooting Procedures in Section 2.5.
3. If an error is detected on the hard disk test, perform the HDD Troubleshooting Procedures in Section 2.6.
4. If an error is detected on the keyboard test (DIAGNOSTICS TEST) and pressed key display test (ONLY ONE TEST), perform the Keyboard/Touch pad Troubleshooting Procedures in Section 2.7.
5. If an error is detected on the display test, perform the Display Troubleshooting Procedures in Section 2.8.
6. If an error is detected on the CD-ROM/DVD-ROM test, perform the Optical Drive Troubleshooting Procedures in Section 2.9.
7. If an error is detected on the modem test, perform the Modem Troubleshooting Procedures in Section 2.10.
8. If an error is detected on the LAN test, perform the LAN Troubleshooting Procedures in Section 2.11.
9. If an error is detected on the Bluetooth test, perform the Bluetooth Troubleshooting Procedures in Section 2.12.
10. If an error is detected on the Wireless LAN test, perform the Wireless LAN Troubleshooting Procedures in Section 2.13.
11. If an error is detected on the Sound test, perform the Sound Troubleshooting Procedures in Section 2.14.
12. If a malfunction is detected on Bridge media, perform the Bridge media slot Troubleshooting Procedures in Section 2.15.
13. If a malfunction is detected on Fingerprint sensor, perform the Fingerprint sensor Troubleshooting Procedures in Section 2.16.

2.3 Power Supply Troubleshooting

The power supply controls many functions and components. To determine if the power supply is functioning properly, start with Procedure 1 and continue with the other Procedures as instructed. The procedures described in this section are:

Procedure 1: Icons in the LCD Check

Procedure 2: Error Code Check

Procedure 3: Connection Check

Procedure 4: Charge Check

Procedure 5: Replacement Check

Procedure 1 Icons in the LCD Check

The following Icons in the LCD indicate the power supply status:

- Battery icon
- DC IN icon

The Power Supply Controller (PSC) displays the power supply status through the Battery icon and the DC IN icon in the LCD as listed in the tables below. To check the power supply status, install a battery pack and connect an AC adaptor.

Table 2-1 Battery icon

Battery icon	Power supply status
Lights orange	Battery is charged and the external DC is input. It has no relation with ON/OFF of the system power.
Lights Blue	Battery is fully charged and the external DC is input. It has no relation with ON/OFF of the system power.
Blinks orange (even intervals)	The battery level is low while the system power is ON.
Blinks orange once (at being switched on)	The system is driven by only a battery and the battery level is low.
Doesn't light	Any condition other than those above.

Table 2-2 DC IN icon

DC IN icon	Power supply status
Lights Blue	DC power is being supplied from the AC adapter.
Flashes orange	There is a problem with the power supply. *1
Doesn't light	Any condition other than those above.

*1 When the Power Supply Controller (PSC) detects a malfunction, the DC IN icon blinks orange. It shows an error code.

When the icon is blinking, perform the following procedure.

1. Remove the battery pack and the AC adapter.
2. Re-attach the battery pack and the AC adapter.

If the icon is still blinking after the operation above, check the followings:

Check 1 If the DC IN icon blinks orange, go to Procedure 2.

Check 2 If the DC IN icon does not light, go to Procedure 3.

Check 3 If the battery icon does not light orange or blue, go to Procedure 4.

NOTE: Use a supplied AC adapter G71C0002SC10, G71C00043310 (2-pin)/ G71C0004A510, G71C00049510 (3-pin).

Procedure 2 Error Code Check

If the power supply microprocessor detects a malfunction, the DC IN icon blinks orange. The blink pattern indicates an error as shown below.

- Start Off for 2 seconds
- Error code (8 bit)
 - “1” On for one second
 - “0” On for half second
 - Interval between data bits Off for half second

The error code begins with the least significant digit.

Example: Error code 11h (Error codes are given in hexadecimal format.)

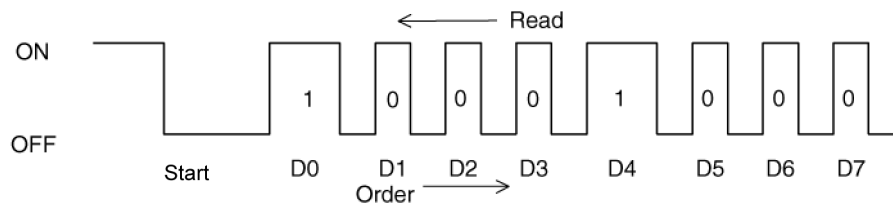

Check 1 Convert the DC IN icon blink pattern into the hexadecimal error code and compare it to the tables below. Then go to Check 2.

Table 2-3 Error code

Error code	Where Error occurs
1*h	AC Adaptor
2*h	1st Battery
3*h	2nd Battery
4*h	S3V output
5*h	E5V output
6*h	E3V output
7*h	1R5-E1V output
8*h	1R8-B1V output
9*h	PPV output
A*h	PTV output
B*h	1R5-E1V output
C*h	1R8-B1V output
D*h	PPV output
E*h	PTV output
F*h	-

Compare the patterns in the hexadecimal error code to the tables below.

AC Adaptor

Error code	Meaning
10h	AC Adaptor output voltage is over 16.5V.
11h	CommonDock voltage is over 16.5V.
12h	Current from the DC power supply is over 7.00A.
13h	Current from the DC power supply is over 0.5A when there is no load.
14h	Correction value of 0[A] is out of designed value.

1st Battery

Error code	Meaning
22h	1st battery discharge current over 0.5A when there is no load.
23h	1st battery charge current is over 3.9A in charging.
24h	Correction value of 0[A] is out of designed value.
25h	1st battery charge current is over 0.3A in not charging.

2nd Battery

Error code	Meaning
32h	2nd battery discharge current is over 0.5A when there is no load.
33h	2nd battery charge current is over 3.9A in charging.
34h	Correction value of 0[A] is out of designed value.
35h	2nd battery charge current is over 0.3A in not charging.

S3V output

Error code	Meaning
40h	S3V voltage is 3.47V or less when the computer is powered on/off.
45h	S3V voltage is under 3.14V in normal conditions.
46h	S3V voltage is under 3.14V when the computer is booting up.

E5V output

Error code	Meaning
50h	E5V voltage is over 6.00V when the computer is powered on/off.
51h	E5V voltage is under 4.50V when the computer is powered on.
52h	E5V voltage is under 4.50V when the computer is booting up.
54h	E5V voltage is under 4.50V when EV power is maintained.

E3V output

Error code	Meaning
60h	E3V voltage is over 3.96V when the computer is powered on/off.
61h	E3V voltage is under 2.81V when the computer is powered on.
62h	E3V voltage is under 2.81V when the computer is booting up.
64h	E3V voltage is under 2.81 V when EV power is maintained.

1R5-E1V output

Error code	Meaning
70h	1R5-E1V voltage is over 1.80V when the computer is powered on/off.
71h	1R5-E1V voltage is under 1.275V when the computer is powered on.
72h	1R5-E1V voltage is under 1.275V when the computer is booting up.
74h	1R5-E1V voltage is under 1.275V when EV power is maintained.

❑ 1R8-B1V output

Error code	Meaning
80h	1R8-B1V voltage is over 2.16V when the computer is powered on/off.
81h	1R8-B1V voltage is under 1.53V when the computer is powered on.
82h	1R8-B1V voltage is under 1.53V when the computer is booting up.
84h	1R8-B1V voltage is under 1.53V when BV power is maintained.

❑ PPV output

Error code	Meaning
90h	PPV voltage is over 1.80V when the computer is powered on/off.
91h	PPV voltage is under 0.32V when the computer is powered on.
92h	PPV voltage is under 0.32V when the computer is booting up.

❑ PTV output

Error code	Meaning
A0h	PTV voltage is over 1.26V when the computer is powered on/off.
A1h	PTV voltage is under 0.89V when the computer is powered on.
A2h	PTV voltage is under 0.89V when the computer is booting up.

❑ 1R5-E1V output

Error code	Meaning
B0h	1R5-E1V voltage is over 1.80V when the computer is powered on/off.
B1h	1R5-E1V voltage is under 1.275V when the computer is powered on.
B2h	1R5-E1V voltage is under 1.275V when the computer is booting up.
B3h	1R5-E1V voltage is under 1.275V when EV power is maintained.

1R8-B1V output

Error code	Meaning
C0h	1R8-B1V voltage is over 2.16V when the computer is powered on/off.
C1h	1R8-B1V voltage is under 1.53V when the computer is powered on.
C2h	1R8-B1V voltage is under 1.53V when the computer is booting up.
C4h	1R8-B1V voltage is under 1.53V when BV power is maintained.

PPV output

Error code	Meaning
D0h	PPV voltage is over 1.80V when the computer is powered on/off.
D1h	PPV voltage is under 0.32V when the computer is powered on.
D2h	PPV voltage is under 0.32V when the computer is booting up.

PTV output

Error code	Meaning
E0h	PTV voltage is over 1.26V when the computer is powered on/off.
E1h	PTV voltage is under 0.89V when the computer is powered on.
E2h	PTV voltage is under 0.89V when the computer is booting up.

Miscellaneous

Error code	Meaning
F0h	The sub clock does not oscillate.

Check 2 In the case of error code 10h or 12h:

- Make sure the AC adaptor cord and AC power cord are firmly plugged into the DC IN 15 V socket and wall outlet. If the cables are connected correctly, go to the following step:
- Connect a new AC adaptor and/or AC power cord, if necessary. If the error still exists, go to Procedure 5.

Check 3 In the case of error code 22h to 25h:

- Make sure the battery pack is correctly installed in the computer. If the battery pack is correctly installed, go to the following step:
- Replace the battery pack with a new one. If the error still exists, go to Procedure 5.

Check 4 For any other error, go to Procedure 5.

Procedure 3 Connection Check

The power supply wiring diagram is shown below:

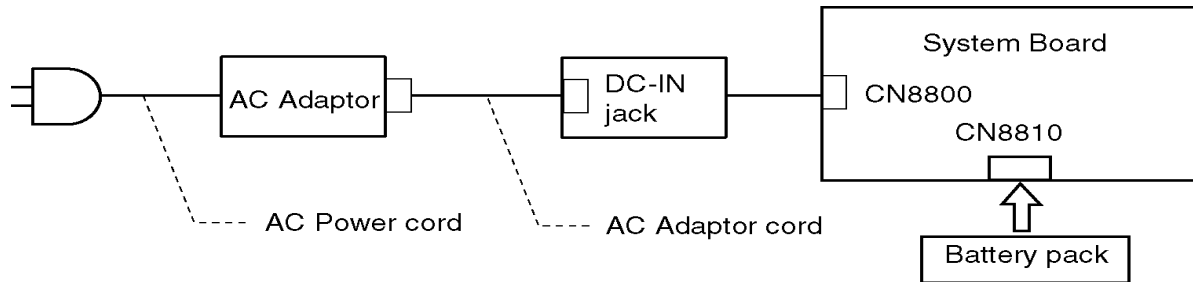

Any of the connectors may be disconnected. Perform Check 1.

- Check 1 Disconnect the AC power cord from the wall outlet. Check the power cable for breaks. If the power cord is damaged, connect a new AC power cord. If there is no damage, go to Check 2.
- Check 2 Make sure the AC adaptor cord and AC power cord are firmly plugged into the DC-IN jack socket and AC adaptor inlet/wall outlet, respectively. If these cables are connected correctly, go to Check 3.
- Check 3 Make sure the DC IN jack is firmly connected to the connector CN8800 on the system board.
- If the DC IN jack is not firmly connected, go to Procedure 5.
 - If it is connected, go to Check 4.
- Check 4 Use a multimeter to make sure the AC adaptor output voltage is close to 15 V. If the output is several percent lower than 15 V, go to Check 5. If the output is close to 15 V, go to Check 6.
- Check 5 Connect a new AC adaptor or AC power cord.
- If the DC IN icon does not light, go to Procedure 5.
 - If the battery icon does not light, go to Check 6.
- Check 6 Make sure the battery pack is installed in the computer correctly. If the battery is properly installed and the battery icon still does not light, go to Procedure 4.

Procedure 4 Charge Check

- Check 1 Make sure the AC adaptor and AC power cord are firmly plugged into the DC IN socket and the wall outlet. If these cables are connected correctly, replace the AC adaptor (and/or AC power cord, if necessary).
- Check 2 Make sure the battery is properly installed. If the battery is properly installed, go to Check 3.
- Check 3 The battery pack may be completely discharged. Wait a few minutes to charge the battery pack. If the battery pack is still not charged, go to Check 4.
- Check 4 The battery's temperature is too hot or cold. Return the temperature to a normal operating condition. If the battery pack still is not charged, go to Check 5.
- Check 5 Replace the battery pack with a new one. If the battery pack still is not charged, go to Procedure 5.

Procedure 5 Replacement Check

The system board processor module may be disconnected or damaged. Disassemble the computer following the steps described in Chapter 4, *Replacement Procedures*. Check the connection between the AC adaptor and system board and connection. After checking the connections, perform the following Check 1:

When AC adapter is connected:

Check 1 AC adapter may be faulty. Replace the AC adapter with a new one. If the problem still occurs, perform Check 2.

Check 2 System board may be faulty. Replace the system board with a new one.

When AC adapter is not connected:
(When driving with battery pack)

Check 1 Battery pack may be faulty. Replace it with a new one. If the problem still occurs, perform Check 2.

Check 2 System board may be faulty. Replace it with a new one.

2.4 System Board Troubleshooting

This section describes how to determine if the system board and CPU are defective or not functioning properly. Start with Procedure 1 and continue with the other procedures as instructed.

The procedures described in this section are:

Procedure 1: Message Check

Procedure 2: Debugging Port Check (Boot Mode)

Procedure 3: Diagnostic Test Program Execution Check

Procedure 4: Replacement Check

Procedure 1 Message Check

When the power is turned on, the system performs the Initial Reliability Test (IRT) installed in the BIOS ROM. The IRT tests each IC on the system board and initializes it.

- If an error message is shown on the display, perform Check 1.
- If there is no error message, go to Procedure 2.
- If Toshiba MS-DOS or Windows XP is properly loaded, go to Procedure 3.

Check 1 If one of the following error messages appears on the screen, press **F1** as the message instructs. These errors occur when the system configuration preserved in the RTC memory (CMOS type memory) is not the same as the actual configuration or when the data is lost.

If you press **F1** as the message instructs, returns all system settings to their default values. Then the system reboots.

If error message (b) appears often when the power is turned on, replace the RTC battery. If any other error message displays, perform Check 2.

- (a) *** Bad HDD type ***
Check system. Then press [F1] key
- (b) *** RTC battery is low or CMOS checksum is inconsistent ***
Press [F1] key to set Date/Time
- (c) *** Bad configuration ***
Check system. Then press [F1] key
- (d) *** Bad memory size ***
Check system. Then press [F1] key
- (e) *** Bad time function ***
Check system. Then press [F1] key
- (g) *** Bad check sum (ROM) ***
Check system. Then press [F1] key

Check 2 If the following error message is displayed on the screen, press any key as the message instructs.
The following error message appears when data stored in RAM under the resume function is lost because the battery has become discharged or the system board is damaged. Go to Procedure 3.

```
WARNING: RESUME FAILURE.  
PRESS ANY KEY TO CONTINUE.
```

If any other error message displays, perform Check 3.

Check 3 The IRT checks the system board. When the IRT detects an error, the system stops or an error message appears.

If one of the following error messages (1) through (15), (20) or (21) appears, go to Procedure 4.

If the error message (16) appears, go to the Keyboard Troubleshooting Procedures in Section 2.7.

If the error message (17) or (18) appears, go to the HDD Troubleshooting Procedures in Section 2.6.

If the error message (19) appears, go to the Optical Drive Troubleshooting Procedures in Section 2.9.

- (1) PIT ERROR
- (2) MEMORY REFRESH ERROR
- (3) TIMER CH.2 OUT ERROR
- (4) FIRST 64KB MEMORY ERROR
- (5) FIRST 64KB MEMORY PARITY ERROR
- (6) VRAM ERROR
- (7) SYSTEM MEMORY ERROR
- (8) SYSTEM MEMORY PARITY ERROR
- (9) MEMORY ERROR
- (10) EXTENDED MEMORY PARITY ERROR
- (11) DMA PAGE REGISTER ERROR
- (12) DMAC #1 ERROR
- (13) DMAC #2 ERROR
- (14) PIC #1 ERROR
- (15) PIC #2 ERROR
- (16) KBC ERROR
- (17) HDC ERROR
- (18) Built-in HDD ERROR
- (19) CD-ROM ERROR
- (20) TIMER INTERRUPT ERROR
- (21) RTC UPDATE ERROR

Procedure 2 Debugging Port Check (Boot Mode)

Check the D port status by a debug port test. The tool for debug port test is shown below.

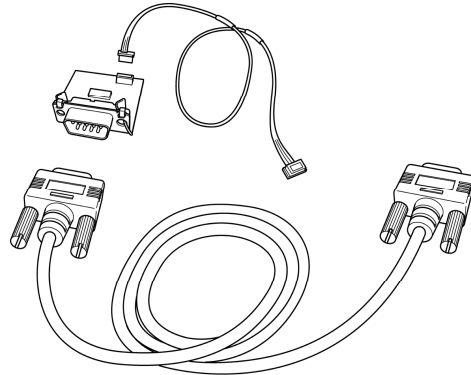
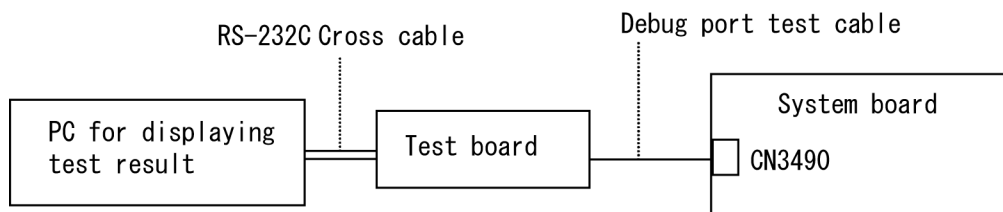

Figure 2-1 A set of tool for debug port test

The test procedures are follows:

1. Connect the debug port test cable to the connector CN3490 of the system board. For disassembling to connect the test cable, refer to Chapter 4.
2. Connect the debug port test cable and RS-232C cross-cable to the test board.
3. Connect the RS-232C Cross-cable to the PC that displays the test results.



4. Boot the computer in MS-DOS mode.
5. Execute GETDPORT.COM in the text menu in CPU REAL mode. (Insert the FD for starting D port into FDD and input “FD starting drive:>dport”.)

The D port status is displayed in the following form;

F100 : 000.000382	IRT_CHK_INI\SYSI_START
D port status	Contents of process
Time (second) to process	

6. When the D port status is FFFFh (normal status), go to Procedure 4.

When the D port status falls into any status in Table 2-4, execute Check 1.

Table 2-4 Debug port (Boot mode) error status (1/10)

D port status	Inspection items	Details
Boot block	Permission of A20 and Clear of software reset bit	
	Prohibition of APIC	
	Initialization of MCH and ICH	
	Initialization of Super I/O	
	Initialization of debug port	
	Dummy read of 3rd Bus data	
	Setting of printer port	
F000H	BTBK_START	
	Only PIT CH0 initialization (for HOLD_ON)	
	BIOS rewrite factor flag initialization	
	CHECK SUM CHECK	Transition to protected mode Boot block checksum (skip when returned to S3) (halts when error) Checksum other than boot block (skip when returned to S3)
F001H	BTBK_CALC_CHKSUM_END	
	EC/KBC rewrite check	If "rewrite" is requested, go to "BIOS rewrite process"
	Key input	
	When a key is pressed, check if it is Tilde key or Tab key	
F002H	BTBK_INI_SC_START	
	Initialization of SC	
F003H	BTBK_INI_SC_ERR	
F004H	BTBK_SC_HW_FAILURE	
F005H	BTBK_INI_KBC_END	
	BIOS rewrite request check	If Checksum check error occurred on except Boot Block or rewrite is required by user, go to "BIOS rewrite process".
F006H	BTBK_ENTER_CHK_BIOS_SIGN	
	BIOS signature check	
F007H	BTBK_ENTER_SYSTEM_BIOS	
	Transits to System BIOS IRT	
	BIOS rewrite process	Initialization of ICHM. D31

Table 2-4 Debug port (Boot mode) error status (2/10)

D port status	Inspection items	Details
(F007H)		DRAM configuration
		Permission of cache (L1 cache only)
		Memory clear
F008H	BTBK_INI_MEM_END	
	Transition to real mode and copy of BIOS to RAM	
F009H	BTBK_CHG_RAM_BIOS	
	Saving key scan code	
F00AH	BTBK_INI_VGA_END	
	Controlling fan	
	Initializing sound items (for BEEP)	Permission of system speaker
		Releasing mute
		Making the volume max (model that can control volume)
When request BIOS, EC/KBC rewriting	Blinks green (cycle:2s, on:1s, off:1s)	
F00BH	BTBK_CANT_UPDATE_BIOS	
	When BIOS renewal is prohibited	Blinks orange (cycle: 2s(On:1s,Off:1s))
	Key input	Prohibition of USB
		BEEP
		Waiting for key input
	Reading CHGBIOSA.EXE / CHGFIRMA.EXE	FDC reset
		Setting parameters for 2HD(1.44MB)
		Reading of first sector, If it is the data of 1.44MB (2HD), the media type is definite.
		Setting of parameters for 2DD (720KB)
		Retrieval of "CHGBIOSA.EXE" from the root directory.
		Directory start header and calculates the sector
		Read 1 sector of the root directory
		Retrieval of entry of "CHGBIOSA.EXE" /"CHGFIRMA.EXE" from the sector read.
Reading of EXE header of "CHGBIOSA.EXE" and "CHGFIRMA.EXE" Key input when error occurred		
Execution of "CHGBIOSA.EXE" and "CHGFIRMA.EXE"		

Table 2-4 Debug port (Boot mode) error status (3/10)

D port status	Inspection items	Details	
F100H	IRT_START		
	Process of cache control for HyperThreading		
	Prohibition of cache		
	Initialization of H/W (before DRAM recognition)	Initialization of MCHM	
		Initialization of ICH4M.D31.Func0	
		Initialization of ICH4M.D31.Func1	
		Initialization of USB.Func0,1,2,7	
		Initialization of ICH4M.D31.Func3	
Initialization of ICH4M.D31.Func5			
Initialization of FLUTE			
Initialization of PIT channel 1	(Setting the refresh interval to "30μs")		
F101H	IRT_INI_SPREG_END		
	Check of DRAM type and size (at cold boot)	When unsupported memory is connected, becoming HLT after beep sound (HLT when DRAM size is 0)	
	SM-RAM stack area test	HLT When it can not be used as a stack	
F102H	Cache configuration		
	Cache permission (L1/L2 Cache)		
	CMOS access test (at cold boot)	(HLT when an error is detected)	
	Battery level check of CMOS		
	CMOS checksum check		
	Initialization of CMOS data (1)		
	Setting of IRT status	(Setting of boot status and IRT busy flag, The rest bits are 0)	
	Storing DRAM size in CMOS		
	Cache configuration		
F103H	IRT_RSM_BRANCH		
	Resume branch (at cold boot)	Not resume when a CMOS error occurred	
		Not resume when resume status code is not set	
		Resume error check	
	S3 returning error (ICH) Resume error F170 RSM_UNKNOWN_ERR		

Table 2-4 Debug port (Boot mode) error status (4/10)

D port status	Inspection items	Details
(F103)		SM-RAM checksum check Resume error F173H RSM_SMRAM_ERR
		Check of memory configuration change Resume error F174H RSM_SYSMEM_ERR
		RAM area checksum check in system BIOS Resume error F179H SM_RAMBIOS_ERR
		Expansion memory checksum check Resume error F176H RSM_EXTMEM_ERR
		PnP RAM checksum check Resume error F177H RSM_PNPRAM_ERR
	Transition to RESUME-MAIN	
	Resume error process	Reset of CPU clock to low
		Prohibition of all SMI
		Clearance of resume status
		Return to ROM
Turning area of C0000h to EFFFFh to PCI (Prohibition of DRAM)		
	Setting of resume error request	
Copying ROM/RAM of system BIOS	(HLT, when error occurs)	
F104H	IRT_BIOS_SIGN_CHK	
	Check of BIOS signature (At COLD Boot)	
F105H	IRT_CHG_RAM_BIOS_END	
	SMRAM initialization	
	Check of CPU for HyperThreading	
	Microcode update	
	APIC initialization	
	WakeUp factor check	
	SMRAM base rewriting and CPU state map saving for BIOS	
	Permission of SMI based on ASMI	

Table 2-4 Debug port (Boot mode) error status (5/10)

D port status	Inspection items	Details	
F106H	IRT_INI_SMBASE_END		
	Initialization of devices which need initialization before PCI bus initialization	PIT test (Cold boot only) and initialization Setting of test pattern to channel 0 of PIT#0 Check whether the set test pattern can be read Initialization of PIT channel 0 (Setting of timer interruption interval to 55ms) Initialization of PIT channel 2 (Setting of the sound generator frequency to 664Hz) Test of PIT channel 1 (Check whether the refresh signal works normally in 30 micro-s refresh interval) HLT, when the time is out Test of PIT channel 2 (Check whether the speaker gate works normally)	
		CPU clock measurement	
		Check of parameter block A	
		Permission of SMI except auto-off function	
		Control of excess of rated input power	
		Battery discharging current control (1CmA)	
		AC adapter rated over current control	
		Dividing procedures for time measuring by IRT	
		Setting for clock generator	
		CPU Initialization Judgment of CPU type Check of supporting Geyserville Make CPU clock High	
		Setting of Graphics Aperture Size	
	F107H	IRT_CHK_INI_SYS1_END	
		Saving memory configuration to buffer	
Reading of EC version			
Update of flash ROM type			
Judging of destination (Japan or other than Japan) based on DMI data			
CMOS default setting check		Sets default setting if bad battery or bad checksum (ROM, CMOS) is detected	
ACPI table initialization (for execution of option ROM)			

Table 2-4 Debug port (Boot mode) error status (6/10)

D port status	Inspection items	Details
(F107H)	Initialization of devices which need initialization before PCI bus initialization	AC97' control
		Initialization of temperature control information
		KBC initialization
		VGA display off, Reset control
		Sound initialization
		PC multi-box status acquisition
		HC initialization, USB device connection recognition and initialization
		Control of built-in LAN permission/prohibition
	PIC initialization	
	PIC test	
	Password Initialization	
F108H	IRT_CHK_INI_SYS2_END	
	PCI bus initialization	(connection of DS Bus)
	Initialization of LAN information	
	Check of WakeUp factor	
F109H	IRT_INI_PCI_END	
	Task generation for waiting INIT_PCI completion	
	CMOS data initialization (2)	
	PnP initialization	
	Setting of setup items	
	Waiting for the completion of Multi-box status check	
	H/W setting based on resource	
F10AH	IRT_MK_SYSRES_END	
	Task generation for waiting PnP resource making completion	
	Control of serial interrupt (Execute before using interrupt)	
	PnP H/W initialization	PC card slot initialization
		SIO initialization (for models supporting SIO)
		FIR initialization (for models supporting FIR)
	PCI automatic configuration	Making of work for automatic configuration
Acquisition of PCI IRQ		

Table 2-4 Debug port (Boot mode) error status (7/10)

D port status	Inspection items	Details	
(F10AH)		Configuration	
		Saving of VGA configuration result	
F10BH	IRT_PCI_CONF_END		
		Task generation for waiting PCI_CONFIGURATION completion	
	Initialization of H/W needed after PCI configuration		Printer port setting (for models supporting printer)
			HDD initialization sequence start
			FDD initialization sequence start (for models supporting printer internal FDD)
		Enabling power off	
		Output code generation	
F10CH	IRT_CHK_INI_SYS3_END		
	FIRST_64KB_CHECK	(Check of first 64KB memory)	
F10DH	IRT_CHK_F64KB_END		
	INIT_INT_VECTOR	(Initialization of vectors)	
F10EH	IRT_INI_VECT_END		
	INIT_NDP	(Initialization of NDP)	
F10FH	IRT_INI_NDP_END		
	INIT_SYSTEM (Initialization of system)	Storing of CMOS error status to IRT_ERR_STS_BUF	
		Timer initialization start	
		EC initialization & Reading of battery information	
		Update of system BIOS (Update of EDID information for LCD)	
F110H	IRT_INI_SYS_END		
	INIT_DISPLAY	(Waiting for VGA chip initialization completion, VGA BIOS initialization)	
F111H	IRT_VGA_POST_START		
	VGA POST		
F112H	IRT_VGA_POST_END		
F113H	IRT_INI_DISP_END		
	DISP_LOGO	(Displaying logo)	
F114H	IRT_DISP_LOGO_END		
	SYS_MEM_CHECK	(Check of convention memory)(Boot)	

Table 2-4 Debug port (Boot mode) error status (8/10)

D port status	Inspection items	Details
F115H	IRT_SYSMEM_CHK_END	
	EXT_MEM_CHECK	(Check of exception in the protected mode)(Boot)
F116H	IRT_EXTMEM_CHK_END	
	Exception check in the protected mode	Dport=F117h when error occurs
	INIT_SYS_MEM	Initialization of conventional memory (Reboot)
F118H	IRT_INI_SYSMEM_END	
	CHK_DMA_PAGE	(Check of DMA Page Register) (Boot)
F119H	IRT_DMA_PAGE_END	
	CHECK_DMAC	(Initialization of DMAC) (Boot)
F11AH	IRT_CHK_DMAC_END	
	INIT_DMAC	(Initialization of DMA) (Boot)
F11BH	IRT_INI_DMAC_END	
	CHECK_PRT	(Check of printer existence) (For models supporting Printer port)
F11CH	IRT_CHK_PRT_END	
	CHECK_SIO	(Check of SIO) (model supporting SIO)
F11DH	IRT_CHK_SIO_END	
	BOOT_PASSWORD	(Check of password)
		Waiting for FDD initialization completion
		(In the case of "Reboot")
		Waiting for HDD initialization completion
		Check of key input during IRT (waiting for KBC initialization completion)
		Initialization of ATA priority
		(In the case of "Boot")
		BM loading process (for models supporting fingerprint authentication)
		Initialization of BM (for models supporting fingerprint authentication)
		Check of key input during IRT (waiting for KBC initialization completion)
Input of password		
BM releasing (for models supporting fingerprint authentication)		

Table 2-4 Debug port (Boot mode) error status (9/10)

D port status	Inspection items	Details
F11EH	IRT_WAIT_SMI_SEQ_END	
F11FH	IRT_PASSWORD_END	
	EX_IO_ROM_CHECK	(Check of option I/O ROM)
F120H	IRT_EX_IO_ROM_END	
	PRE_BOOT_SETUP	Saving of value in 40:00h (for SIO saving/restoring)
		Setting of font address for resume password
		Setting of repeat parameter for USB KB
		Final check of key input during IRT
		Storing of T_SHADOW_RAM_SIZE
		Update of system resource just before booting
		Rewriting of memory map data of INT15h E820h function
		Waiting for AC-Link initialization completion
		Renewal of table for DMI
		Copying ACPI table to uppermost of extension memory
		Waiting for completion of setting clock generator When error occurred, halt at F121 IRT_CLOCK_GENERATOR_ERR
		Waiting for completion of initialization of Serial port (for models supporting SIO)
		Cancel of NMI Mask
		TIT check sum
		Clear of the IRT flag of Runtime side
		Update of check sum of Runtime side
		Hibernation branch (for models supporting BIOS Hibernation)
		Initialization of Bluetooth (for models supporting Bluetooth)
		Check for existence of target maintenance card
Prohibition of unused PC card not used		
Setting Wakeup status data for ACPI		
HW initialization just before booting, Waiting for initialization completion		

Table 2-4 Debug port (Boot mode) error status (10/10)

D port status	Inspection items	Details
F122H	IRT_SC_INIT_START	
F123H		Notifies the DVI connection status to VGA BIOS (for models supporting DVI) Setting of battery save mode Setting of date Waiting for Bluetooth initialization completion (for models supporting Bluetooth) Update of DMI Wakeup factor, Update of SM-BIOS structure table PCI device configuration space close Cache control Renewal of parameter block A Process for CPU Make the CPU clock to be set by SETUP Waiting of motor-off completion of disabled HDD Final decision of USB FDD drive information Post processing of PRE_BOOT_SETUP Clear of PWRBTN_STS Enabling POWER Button
F124H	IRT_PRE_BOOT_SETUP_END	
F125H	IRT_WAIT_DISP_LOGO_START	
	Clear of IRT status	
	Renewal of check sum of Runtime side	
FFFFH	IRT_POST_END	

NOTE: Status outputted by the test means the last error detected in the debug port test.

Check 1 If the D port status F11DH or F120H is displayed, go to HDD Trouble shooting Procedure in Section 2.6.

Check 2 If any other D port status error code is displayed, perform Procedure 3.

D port error code is as follows:

Error code	Contents
F117H	Exception check error
F121H	Clock generator error

Procedure 3 Diagnostic Test Program Execution Check

Execute the following tests from the Diagnostic Test Menu. Refer to Chapter 3, *Tests and Diagnostics*, for more information on how to perform these tests.

1. System test
2. Memory test
3. Keyboard test
4. Display test
5. Floppy Disk test
6. Async test
7. Hard Disk test
8. Real Timer test
9. NDP test
10. Expansion test
11. CD-ROM/DVD-ROM test
12. Only One test
13. Wireless LAN test
14. Sound test
15. LAN/Modem/Bluetooth/IEEE1394 test

If an error is detected during these tests, go to Procedure 4.

Procedure 4 Replacement Check

The system board connectors may be disconnected. Disassemble the computer following the steps described in Chapter 4, *Replacement Procedures* and perform Check 1.

Check 1 Visually check for the following:

- a) Cracked or broken connector housing
- b) Damaged connector pins

If their connectors are in good condition, but there is still a problem, go to Check 2.

Check 2 The system board may be damaged. Replace the system board with a new one following the steps described in Chapter 4, *Replacement Procedures*.

2.5 USB FDD Troubleshooting

This section describes how to determine if the USB FDD is functioning properly. Perform the steps below starting with Procedure 1 and continuing with the other procedures as required.

Procedure 1: USB FDD Head Cleaning Check

Procedure 2: Diagnostic Test Program Execution Check

Procedure 3: Connector Check and Replacement Check

Procedure 1 USB FDD Head Cleaning Check

USB FDD head cleaning operation details are given in Chapter 3, *Tests and Diagnostics*.

Connect a USB floppy disk drive to a computer and insert the Diagnostics Disk in the USB floppy disk drive, turn on the computer and run the test. Clean the USB FDD heads using the cleaning kit. If the USB FDD still does not function properly after cleaning, go to Procedure 2.

If the test program cannot be executed, go to Procedure 3.

Procedure 2 Diagnostic Test Program Execution Check

Insert the Diagnostics Disk in the USB FDD, turn on the computer and run the test. Refer to Chapter 3, *Tests and Diagnostics*, for more information about the diagnostics test procedures.

Floppy disk drive test error codes and their status names are listed in Table 2-5. Make sure the floppy disk is formatted correctly and that the write protect tab is disabled. If any other errors occur while executing the FDD diagnostics test, go to Check 1.

Table 2-5 FDD error code and status

Code	Status
01h	Bad command error
02h	Address mark not found
03h	Write protected
04h	Record not found
06h	Media removed
08h	DMA overrun error
09h	DMA boundary error
10h	CRC error
20h	FDC error
40h	Seek error
60h	Not drive error
80h	Time out error
EEh	Write buffer error
FFh	Data compare error

Check 1 If the following message appears, disable the write protect tab on the floppy disk. If any other message appears, perform Check 2.

Write protected

Check 2 Make sure the floppy disk is formatted correctly. If it is, go to Procedure 3.

Procedure 3 Connector Check and Replacement Check

The USB FDD is connected to the System Board.

- Check 1 When using the USB port, make sure the USB FDD cable is firmly connected to CN4612 or CN4614 on the System.

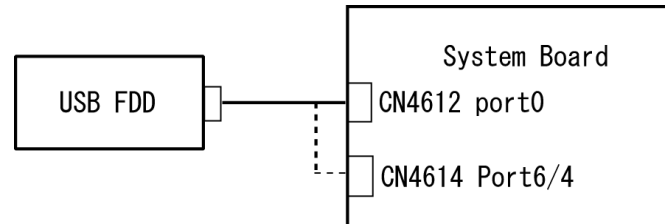

If any of the connections are loose, reconnect firmly and repeat Procedure 2.
If any of the connections is damaged, or there is still an error, go to Check 2.

- Check 2 The USB FDD or USB FDD cable may be defective or damaged. Replace it with a new one. If the USB FDD is still not functioning properly, perform Check 3.
- Check 3 Replace the System board with a new one following the steps in Chapter 4, *Replacement Procedures*.

2.6 HDD Troubleshooting

This section describes how to determine if the HDD is functioning properly. Perform the steps below starting with Procedure 1 and continuing with the other procedures as required.

Procedure 1: Partition Check

Procedure 2: Message Check

Procedure 3: Format Check

Procedure 4: Diagnostic Test Program Execution Check

Procedure 5: Connector Check and Replacement Check

CAUTION: *The contents of the hard disk will be erased when you execute the HDD troubleshooting procedures. Transfer the contents of the hard disk to floppy disks or other storage media.*

Procedure 1 Partition Check

Insert the Toshiba MS-DOS system disk and restart the computer with U key holding down. Perform the following checks:

- Check 1 Type **C:** and press **Enter**. If you cannot change to drive C, go to Check 2. If you can change to drive C, go to Check 3.
- Check 2 Type **FDISK** and press **Enter**. Choose Display Partition Information from the FDISK menu. If drive C is listed, go to Check 3. If drive C is not listed, return to the FDISK menu and choose the option to create a DOS partition on drive C. Restart the computer from the Toshiba MS-DOS system disk. If the problem still exists, go to Procedure 2.
- Check 3 If drive C is listed as active in the FDISK menu, go to Check 4. If drive C is not listed as active, return to the FDISK menu and choose the option to set the active partition for drive C. Restart the computer and then go to Procedure 2.
- Check 4 Remove the FD and restart the computer. If the problem still exists, go to Procedure 3.

Procedure 2 Message Check

When the power is turned on, the system performs the Initial Reliability Test (IRT) installed in the BIOS ROM. When the test detects an error, an error message is displayed on the screen.

Make sure no floppy disk is in the USB FDD. Turn on the computer and check the message on the screen. When an OS starts from the 2.5" HDD, go to Procedure 3. Otherwise, start with Check 1 below and perform the other checks as instructed.

Check 1 If any of the following messages appear, go to Procedure 3. If the following messages do not appear, perform Check 2.

Built-in HDD ERROR (After 5 seconds this message will disappear.)

or

CD-ROM ERROR (After 5 seconds this message will disappear.)

Check 2 If either of the following messages appears, go to Check 3. If the following messages do not appear, perform Check 4.

Insert system disk in drive
Press any key when ready

or

Non-System disk or disk error
Replace and press any key when ready

Check 3 Using the SYS command of the MS-DOS, transfer the system to the 2.5" HDD. If the system is not transferred, go to Procedure 3. Refer to the MS-DOS Manual for detailed operation.

If the following message appears on the display, the system program has been transferred to the HDD.

System Transferred

If an error message appears on the display, perform Check 4.

Check 4 2.5" HDD(s) and the connector(s) of system board may be defective (Refer to the steps described in Chapter 4, *Replacement Procedures* for disassembling.). Insert HDD(s) to the connector(s) firmly. If it is (or they are) firmly connected, go to Procedure 3.

Procedure 3 Format Check

The computer's HDD is formatted using the MS-DOS FORMAT program or the physical format program of the test program. To format the HDD, start with Check 1 below and perform the other steps as required.

Refer to the MS-DOS Manual for the operation of MS-DOS. For the format by the test program, refer to the Chapter 3.

Check 1 Format the 2.5" HDD using MS-DOS FORMAT command. Type as **FORMAT C: /S/U**.

 If the 2.5" HDD can not be formatted, perform Check 2.

Check 2 Using the MS-DOS FDISK command, set the 2.5" HDD partition. If the partition is not set, go to Check 3. If it is set, format the 2.5" HDD using MS-DOS FORMAT command.

Check 3 Using the Diagnostic Disk, format the 2.5" HDD with a format option (physical format). If HDD is formatted, set the 2.5" HDD partition using MS-DOS FDISK command.

 If you cannot format the 2.5" HDD using the Tests and Diagnostic program, go to Procedure 4.

Procedure 4 Diagnostic Test Program Execution Check

The HDD test program is stored in the Diagnostics Disk. Perform all of the HDD tests in the Hard Disk Drive Test. Refer to Chapter 3, *Tests and Diagnostics*, for more information about the HDD test program.

If an error is detected during the HDD test, an error code and status will be displayed. Replace the HDD with a new one following the instructions in Chapter 4, *Replacement Procedures*. The error codes and statuses are listed in Table 2-6. If an error code is not generated or the problem still exists, go to Procedure 5.

Table 2-6 HDD error code and status

Code	Status
01h	Bad command error
02h	Address mark not found
04h	Record not found
05h	HDC not reset
07h	Drive not initialized
08h	Overrun error (DRQ)
09h	DMA boundary error
0Ah	Bad sector error
0Bh	Bad track error
10h	ECC error
11h	ECC recover enable
12h	DMA CRC error
20h	HDC error
40h	Seek error
80h	Time out error
AAh	Drive not ready
BBh	Undefined error
CCh	Write fault
E0h	Status error
EEh	Access time error
DAh	No HDD

Procedure 5 Connector Check and Replacement Check

The HDD may be disconnected, or the HDD, HDD cable or system board may be damaged. Disassemble the computer following the steps described in Chapter 4, *Replacement Procedures* and perform the following checks:

Check 1 Make sure the HDD is firmly connected to CN1850 on the system board.

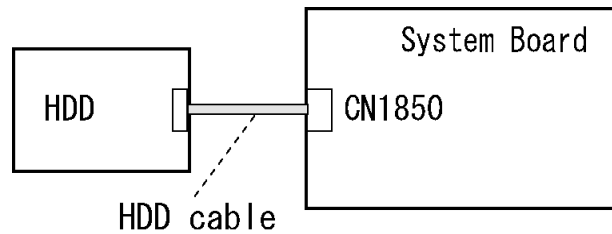

If any of the connections are loose, reconnect firmly and repeat Procedure 1. If there is still an error, go to Check 2.

Check 2 The HDD may be damaged. Replace it with a new one following the instructions in Chapter 4, *Replacement Procedures*. If the problem still exists, perform Check 3.

Check 3 The System board may be damaged. Replace it with a new one following the instructions in Chapter 4, *Replacement Procedures*.

2.7 Keyboard and Touch pad Troubleshooting

To determine if the computer's keyboard or touch pad is functioning properly, perform the following procedures. Start with Procedure 1 and continue with the other procedures as instructed.

Procedure 1: Diagnostic Test Program Execution Check

Procedure 2: Connector Check and Replacement Check

Procedure 1 Diagnostic Test Program Execution Check

Execute the Keyboard Test in the Diagnostic Program. Refer to Chapter 3, *Tests and Diagnostics*, for more information on how to perform the test program.

If an error occurs, go to Procedure 2. If an error does not occur, the keyboard is functioning properly.

Procedure 2 Connector Check and Replacement Check

The keyboard, touch pad or sensor/switch board may be disconnected or damaged. Disassemble the computer following the steps described in Chapter 4, *Replacement Procedures*, and perform the following checks:

1. If the keyboard malfunctions, start with Check 1.
2. If the touch pad malfunctions, start with Check 3.
3. If the SW membrane malfunctions, start with Check 6.

Check 1 Make sure the keyboard cable is securely connected to CN3230 on the system board.

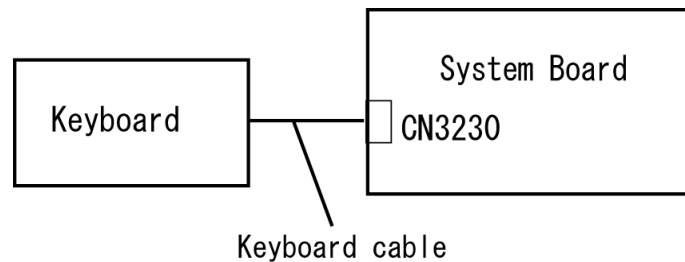

If the connection is loose, reconnect firmly. If there is still an error, go to Check 2.

Check 2 The keyboard or its cable may be damaged. Replace it with a new one following the instructions in Chapter 4, *Replacement Procedures*. If the problem still exists, perform Check 8.

Check 3 Make sure the touch pad cable is firmly connected to CN3240 on the system board.

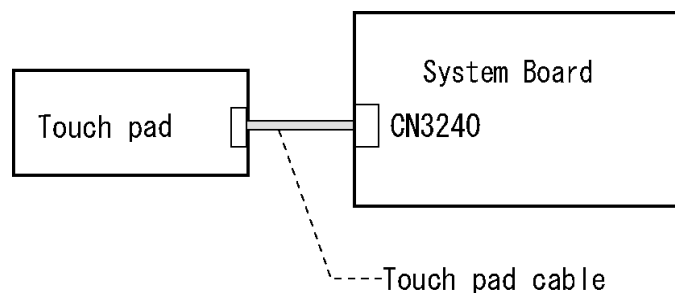

If the connection is loose, reconnect firmly. If there is still an error, go to Check 4.

Check 4 The touch pad may be damaged. Replace it with a new one following the instructions in Chapter 4, *Replacement Procedures*. If the problem still exists, perform Check 5.

- Check 5 The touch pad cable may be damaged. Replace it with a new one following the instructions in Chapter 4, *Replacement Procedures*. If the problem still exists, perform Check 8.
- Check 6 Make sure the SW cable is firmly connected to CN3260 on the system board.

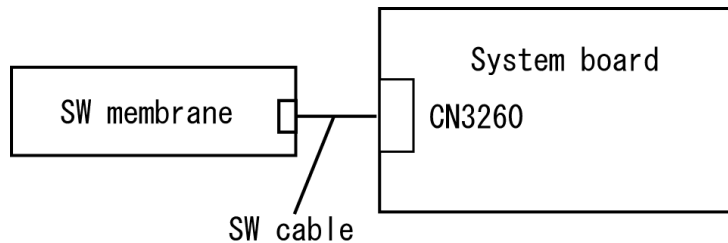

- If the connection is loose, reconnect firmly. If there is still an error, go to Check 7.
- Check 7 The SW membrane may be damaged. Replace it with a new one following the instructions in Chapter 4, *Replacement Procedures*. If the problem still exists, perform Check 8.
- Check 8 The system board may be damaged. Replace it with a new one following the instructions in Chapter 4, *Replacement Procedures*.

2.8 Display Troubleshooting

This section describes how to determine if the computer's display is functioning properly. Start with Procedure 1 and continue with the other procedures as instructed.

Procedure 1: External Monitor Check

Procedure 2: Diagnostic Test Program Execution Check

Procedure 3: Connector Check and Cable Check

Procedure 4: Replacement Check

Procedure 1 External Monitor Check

Connect an external monitor and turn on the computer. If there is no problem on it, the internal LCD may be defective. Go to Procedure 3. If there is any problem on the external monitor, the system board may be defective. Go to Procedure 2.

Procedure 2 Diagnostic Test Program Execution Check

The Display Test program is stored on the computer's Diagnostics disk. This program checks the display controller on the system board. Insert the Diagnostics disk in the computer's floppy disk drive, turn on the computer and run the test. Refer to Chapter 3, *Tests and Diagnostics* for details. If an error is detected, go to Procedure 3.

Procedure 3 Connector Check and Cable Check

Check 1 The LCD, FL, FL Inverter Board and System Board are connected by the HV cable and LCD/FL cable as shown bellow. Check the connections. The connectors may be disconnected or damaged. Disassemble the computer following the steps described in Chapter 4, *Replacement Procedures*.

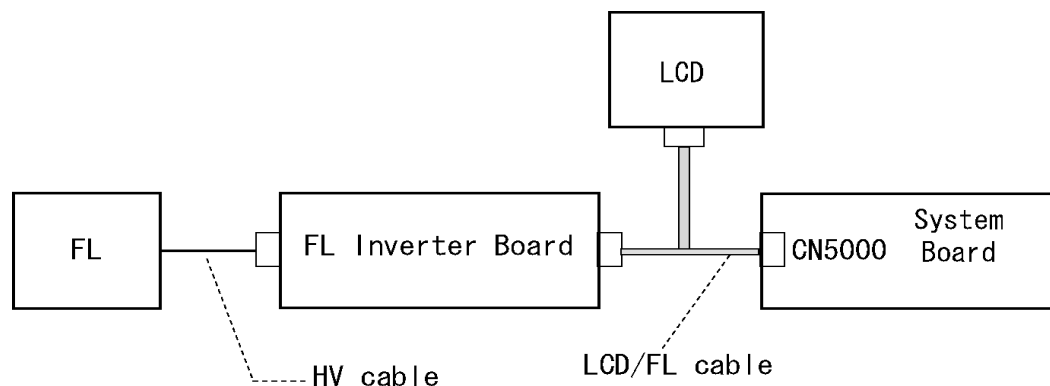

If the connection is loose, reconnect firmly and restart the computer. If there is still an error, go to Procedure 4.

Procedure 4 Replacement Check

The FL, FL inverter board, LCD module, and system board are connected to display circuits. Any of these components may be damaged. Refer to Chapter 4, *Replacement Procedures*, for instructions on how to disassemble the computer and then perform the following checks:

1. If characters or graphics are not displayed clearly, perform Check 1.
2. If some screen functions do not operate properly, perform Check 2.
3. If the FL remains lit when the display is closed, perform Check 4.

- Check 1 Replace the FL with a new one following the instructions in Chapter 4, *Replacement Procedures* and test the display again. If the problem still exists, perform Check 2.
- Check 2 Replace the LCD module with a new one following the instructions in Chapter 4, *Replacement Procedures* and test the display again. If the problem still exists, perform Check 3.
- Check 3 Replace the display cable (FL cable and LCD cable) with a new one following the instructions in Chapter 4, *Replacement Procedures* and test the display again. If the problem still exists, perform Check 4.
- Check 4 The display controller on the system board may be damaged. Replace the system board with a new one following the instructions in Chapter 4, *Replacement Procedures*.

2.9 Optical Drive Troubleshooting

This section describes how to determine if the optical drive (DVD-ROM&CD-R/RW or DVD Super Multi drive) is functioning properly. Perform the steps below starting with Procedure 1 and continue with the other procedures as required.

Procedure 1: Diagnostic Test Program Execution Check

Procedure 2: Connector Check and Replacement Check

Procedure 1 Diagnostic Test Program Execution Check

The CD-ROM/DVD-ROM test program is stored in the Diagnostics Disk.

For the test, prepare test Media.

Then insert the Diagnostics Disk in the USB floppy disk drive, turn on the computer and run the test. Refer to Chapter 3, *Tests and Diagnostics*, for more information about the diagnostics test procedures.

If any errors occur while executing the CD-ROM/DVD-ROM test, go to Procedure 2.

Procedure 2 Connector Check and Replacement Check

The optical drive (DVD-ROM&CD-R/RW or DVD Super Multi drive) is connected to the system board. The connectors may be disconnected from the system board or may be damaged. Disassemble the computer following the steps described in Chapter 4, *Replacement Procedures* and perform the following checks:

Check 1 Make sure the drive to test is firmly connected to CN1810 on the system board.

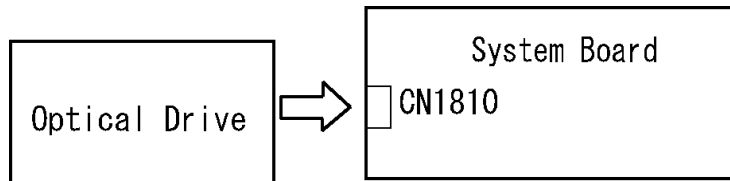

If the connection is loose, reconnect firmly and repeat Procedure 1. If there is still an error, go to Check 2.

Check 2 The drive may be defective or damaged. Replace the drive with a new one. If there is still an error, go to Check 3.

Check 3 Replace the system board with a new one following the steps in Chapter 4, *Replacement Procedures*.

2.10 Modem Troubleshooting

This section describes how to determine if the computer's modem is functioning properly. Perform the steps below starting with Procedure 1 and continuing with the other procedures as required.

Procedure 1: Diagnostic Test Program Execution Check

Procedure 2: Connector Check and Replacement Check

Procedure 1 Diagnostic Test Program Execution Check

Insert the LAN/Modem/Bluetooth/IEEE1394 test program in the USB floppy disk drive, turn on the computer and run the test. Refer to Chapter 3, *Tests and Diagnostics*, for more information about the diagnostics test procedures.

If any errors occur while executing the Sound/Modem/LAN test, go to Procedure 2.

Procedure 2 Connector Check and Replacement Check

The Modem is installed as a MDC (Modem Daughter Card). If the modem malfunctions, there may be a bad connection between the MDC and the system board. Or the MDC, system board or their connectors might be damaged.

Disassemble the computer following the steps described in Chapter 4, *Replacement Procedures* and perform the following checks:

- Check 1 Make sure the MDC is firmly connected to CN3010 on the system board and the Modem cable is firmly connected to the Modem jack.

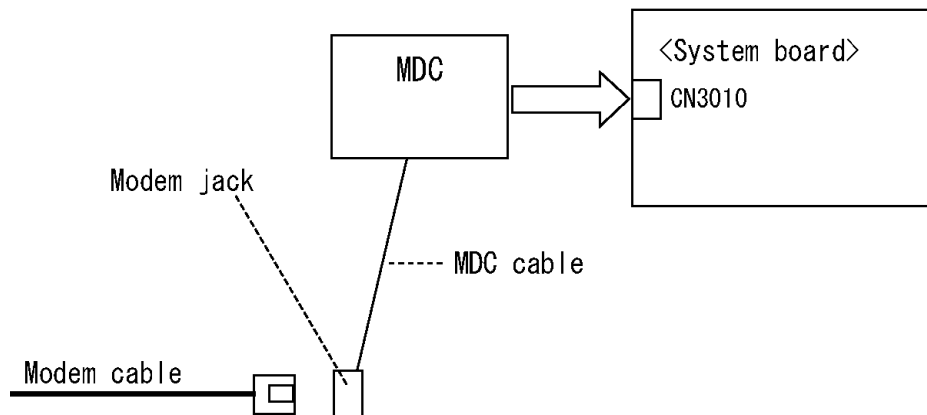

If connections are disconnected, connect them firmly and repeat Procedure 1. If the modem is still not functioning properly, perform Check 2.

- Check 2 The MDC may be defective or damaged. Replace it with a new one following the steps in Chapter 4, *Replacement Procedures*. If the modem is still not functioning properly, perform Check 3.
- Check 3 The MDC cable may be defective or damaged. Replace it with a new one following the steps in Chapter 4, *Replacement Procedures*. If the modem is still not functioning properly, perform Check 4.
- Check 4 The system board may be defective or damaged. Replace it with a new one following the steps in Chapter 4, *Replacement Procedures*.

2.11 LAN Troubleshooting

This section describes how to determine if the computer's LAN is functioning properly. Perform the steps below starting with Procedure 1 and continue with the other procedures as required.

Procedure 1: Diagnostic Test Program Execution Check

Procedure 2: Connector Check and Replacement Check

Procedure 1 Diagnostic Test Program Execution Check

Execute the LAN test program available as part of the LAN/Modem/Bluetooth/IEEE1394 test program. Refer to Chapter 3, *Tests and Diagnostics* for more information on how to perform the test program.

If any error is detected by the test, go to Procedure 2.

Procedure 2 Connector Check and Replacement Check

The RJ-45 jack with LAN cable is connected to the system board. If the LAN malfunctions, the system board might be damaged.

Disassemble the computer following the steps described in Chapter 4, Replacement Procedures and perform the following check:

Check 1 Make sure the RJ-45 jack is firmly connected to CN4100 on the system board.

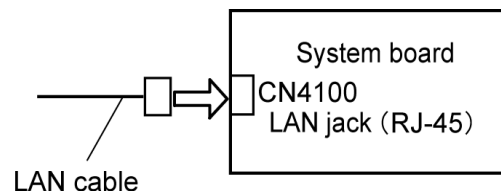

If the connectors are disconnected, connect it firmly and repeat Procedure 1. If the LAN function is still not functioning properly, perform Check 2.

Check 2 The system board may be defective or damaged. Replace it with a new one following the steps in Chapter 4, *Replacement Procedures*.

2.12 Bluetooth Troubleshooting

This section describes how to determine if the computer's Bluetooth is functioning properly. Perform the steps below starting with Procedure 1 and continuing with the other procedures as required.

Procedure 1: Transmitting-Receiving Check

Procedure 2: Connection Check

Procedure 3: Replacement Check

Procedure 1 Transmitting-Receiving Check

Make sure the wireless switch on the left side of the computer is turned "On". If it is not, slide the switch toward the back of the computer to turn it on.

Check 1 Execute Bluetooth test program. Perform the test following the instructions described in Chapter 3, Bluetooth Test Program. You will need a second computer that can communicate by the Bluetooth.

If the computer passes the test, the function is correctly working. If the computer does not pass the test, perform Procedure 2.

Procedure 2 Connection Check

The Bluetooth function wiring diagram is shown below:

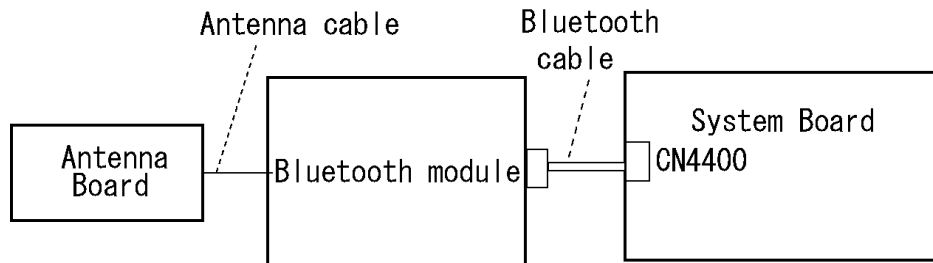

Any of the connections may be disconnected. Disassemble the computer following the steps described in Chapter 4, *Replacement Procedures*, and perform the following checks:

- Check 1 Make sure that the wireless communication switch is “On”.
If the switch is “Off”, turn it “On”. If the problem still occurs, perform Check 2.
- Check 2 Make sure the Bluetooth module is firmly connected to the connector CN4400 on the system board.
If the connector is disconnected, connect it firmly. If the Bluetooth module is still not functioning properly, perform Check 3.
- Check 3 Make sure the Bluetooth antenna cable is firmly connected to the Bluetooth module.
If the Bluetooth antenna cable is disconnected, connect it firmly. If the Bluetooth module is still not functioning properly, go to Procedure 3.

Procedure 3 Replacement Check

The Bluetooth antenna, Bluetooth module, sound board and system board are connected to the circuits. Any of these components may be damaged. Refer to Chapter 4, *Replacement Procedures*, for instructions on how to disassemble the computer and then perform the following checks:

- Check 1 The Bluetooth module may be defective or damaged. Replace the Bluetooth module with a new one following the steps in Chapter 4, *Replacement Procedures*. If the Bluetooth is still not functioning properly, perform Check 2.
- Check 2 The Bluetooth antenna may be defective or damaged. Replace the Bluetooth antenna with a new one following the steps in Chapter 4, *Replacement Procedures*. If the Bluetooth is still not functioning properly, perform Check 3.
- Check 3 The system board may be defective or damaged. Replace the system board with a new one following the steps in Chapter 4, *Replacement Procedures*.

2.13 Wireless LAN Troubleshooting

This section describes how to determine if the computer's Wireless LAN is functioning properly. Perform the steps below starting with Procedure 1 and continuing with the other procedures as required.

Procedure 1: Transmitting-Receiving Check

Procedure 2: Antenna Connection Check

Procedure 3: Replacement Check

Procedure 1 Transmitting-Receiving Check

Make sure the wireless switch on the left side of the computer is turned "On". If it is not, slide the switch toward the back of the computer to turn it on.

Refer to Chapter 3, *Tests and Diagnostics* for more information on how to perform the test program.

Check 1 Execute test program for the wireless LAN function to check the transmitting-receiving function of the wireless LAN. You will need a second computer that can communicate by the wireless LAN.

If the computer passes the test, the function is correctly working.

If the computer does not pass the test, perform Procedure 2.

Procedure 2 Antenna Connection Check

The wireless LAN wiring diagram is shown below:

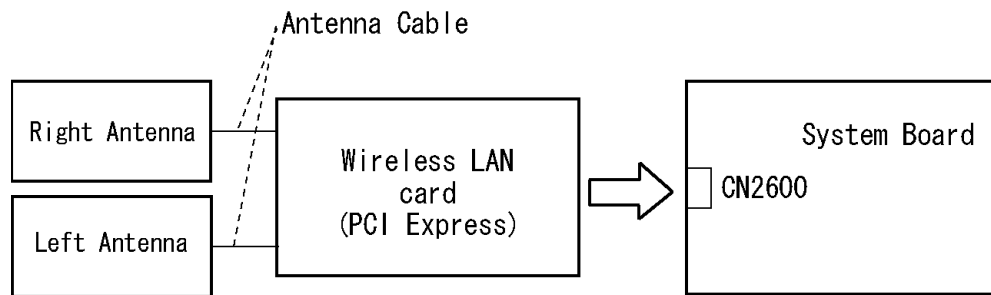

Any of the connections may be disconnected. Disassemble the computer following the steps described in Chapter 4, *Replacement Procedures*, and perform the following checks:

Check 1 Make sure the wireless LAN card is firmly connected to CN2600 on the system board.

If the connector is disconnected, connect it firmly. If the wireless LAN card is still not functioning properly, perform Check 2.

Check 2 Make sure the wireless LAN antenna cables are firmly connected to the wireless LAN card.

If the wireless LAN antenna cables are disconnected, connect them firmly. If the wireless LAN card is still not functioning properly, go to Procedure 3.

Procedure 3 Replacement Check

The wireless LAN antenna, wireless LAN board and the system board are connected to the circuits. Any of these components may be damaged. Refer to Chapter 4, *Replacement Procedures*, for instructions on how to disassemble the computer and then perform the following checks:

Check 1 The wireless LAN card may be defective or damaged. Replace it with a new one following the steps in Chapter 4, *Replacement Procedures*. If the problem still exists, perform Check 2.

Check 2 The wireless LAN antenna may be defective or damaged. Replace the antenna with a new one following the steps in Chapter 4, *Replacement Procedures*. If the problem still exists, perform Check 3.

Check 3 The system board may be defective or damaged. Replace the board with a new one following the instructions in Chapter 4, *Replacement Procedures* and test the display again.

2.14 Sound Troubleshooting

NOTE: *On the Operation Systems other than Windows/Vivace, sounds come from the internal speaker, even if a headphone connected.*

This section describes how to determine if the computer's sound functions are functioning properly. Perform the steps below starting with Procedure 1 and continuing with the other procedures as required.

Procedure 1: Diagnostic Test Program Execution Check

Procedure 2: Connector Check

Procedure 3: Replacement Check

Procedure 1 Diagnostic Test Program Execution Check

Insert the Sound test program in the USB floppy disk drive, turn on the computer and run the test. Refer to Chapter 3, *Tests and Diagnostics*, for details.

If an error is detected, go to Procedure 2.

Procedure 2 Connector Check

The sound function-wiring diagram is shown below:

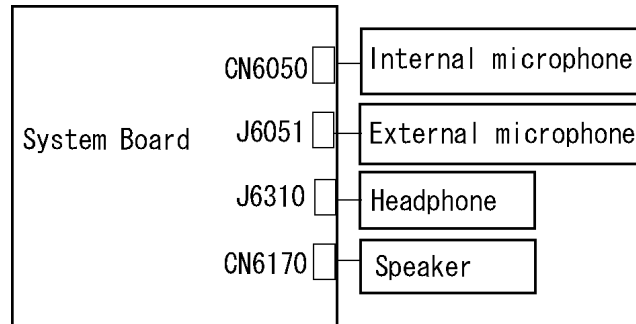

Any of the connections may be disconnected. Disassemble the computer following the steps described in Chapter 4, *Replacement Procedures* and perform the following checks:

- 1 If the stereo speakers do not work correctly, perform Check 1.
- 2 If the headphone does not work correctly, perform Check 2.
- 3 If the microphones do not work correctly, perform Check 3.

Check 1 If the stereo speakers do not work properly, the speaker cable may be disconnected. Make sure the speaker cable is firmly connected to CN6170 on the system board. If the stereo speakers are still not functioning properly, go to Procedure 3.

Check 2 If the headphone does not work properly, the headphone cable may be disconnected. Make sure the headphone cable is firmly connected to J6310 on the system board. If the sound function still does not work properly, Procedure 3.

Check 3 If the microphones do not work properly, the internal microphone cable or external microphone cable may be disconnected. When the internal microphone malfunctions, make sure the internal microphone cable is firmly connected to CN6050 on the system board. When using the external microphone, make sure the external microphone cable is firmly connected to J6051 on the system board. If the microphones are still not functioning properly, go to Procedure 3.

Procedure 3 Replacement Check

- Check 1 If the stereo speakers do not sound properly, the right or left speaker may be defective or damaged. Replace it with a new one. If the stereo speakers still do not work properly, go to Check 3.
- Check 2 If the internal microphones do not work properly, the microphone may be defective or damaged. Replace it with a new one. If the microphone still does not work properly, go to Check 3.
- Check 3 If the headphone or external microphone does not sound properly, the system board may be defective or damaged. Replace the system board with a new one.

2.15 Bridge media Slot Troubleshooting

This section describes how to determine if the computer's SD card functions are functioning properly. Perform the steps below starting with Procedure 1 and continuing with the other procedures as required.

Procedure 1: Check on Windows XP

Procedure 2: Connector Check and Replacement Check

Procedure 1 Check on Windows XP

Insert a Bridge media (SD memory card/SDIO card/Memory stick/Memory stick Pro/xD Picture card/Multimedia card) into the slot. Check if the installed Windows recognizes automatically the Bridge media and the data in the Bridge media can be read.

If the card is not recognized or data are not read, go to Procedure 2.

Procedure 2 Connector Check and Replacement Check

The Bridge media is connected to IS2101 on the system board.

Bridge media supports SD memory card/SDIO card/Memory stick/Memory stick Pro/xD Picture card/Multimedia card.

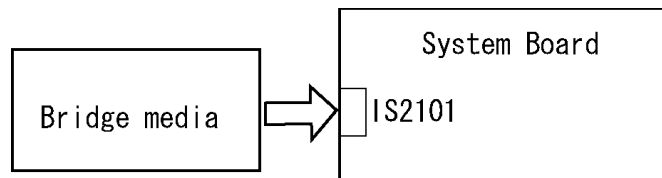

- Check 1 The Bridge media and system board may be disconnected. Make sure the Bridge media is firmly inserted to IS2101 on the system board. If not, insert it firmly. If the Bridge media is still not functioning properly, perform Check 2.
- Check 2 The Bridge media may be faulty. Replace it with a new one following the step in Chapter 4 *Replacement Procedures*. If the problem continues, perform Check 3.
- Check 3 The system board may be faulty. Replace it with a new one following the step in Chapter 4 *Replacement Procedures*.

2.16 Fingerprint sensor Troubleshooting

CAUTION: To delete the account for confirming the fingerprint operation, it is necessary to log on by the account with the management authority. If the password has been set to log on, ask the Log-ON password to the user.

To check if the Fingerprint sensor works correctly or not, follow the troubleshooting procedures below as instructed.

When failed in Procedure 1 to Procedure 3, execute Procedure 4.

Procedure 1: Setting Windows Log-ON password

Procedure 2: Registration of fingerprint

Procedure 3: Authentication of fingerprint

Procedure 4: Connector Check and Replacement Check

CAUTION: Scan your finger shown below.

1. Lay your finger straight to the sensor and put lightly the first joint of your finger at the centerline of the fingerprint sensor.
2. Slide slowly your finger from the first joint to fingertip at constant speed. When not recognized, adjust the speed.

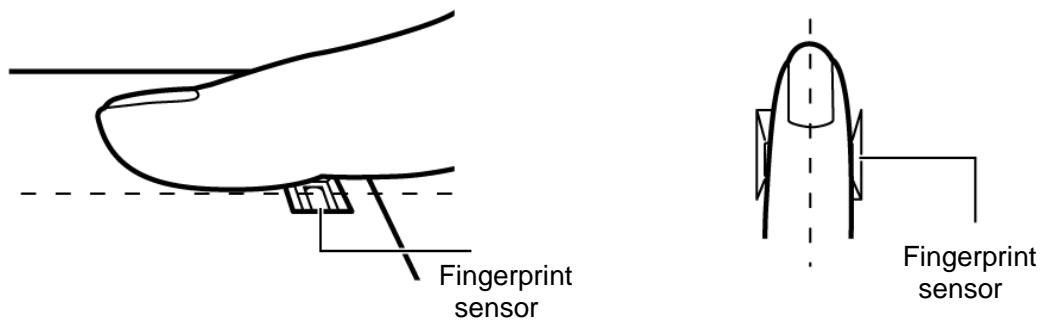

Procedure 1 Setting Windows Log-ON password

1. Open [User Account] from [Control Panel].
2. Click [User Account].
3. Click the icon of the account (user's name) that you want to set the password.
4. Click "Create Account".
5. Type a password in "Type a new password".
6. Press **Tab** key.
7. Type the password again.
8. Click "Create Password" button.
9. When "Do you want to make your files and folders private" appears in [Computer administrator], click [Yes, Make Private].

Procedure 2 Registration of fingerprint

1. Logon by user's account to register the fingerprint.
2. Open [Start] → [All Programs] → [Protector Suite QL] → [User Enrollment].
3. After displaying [User Enrollment], click [Next].

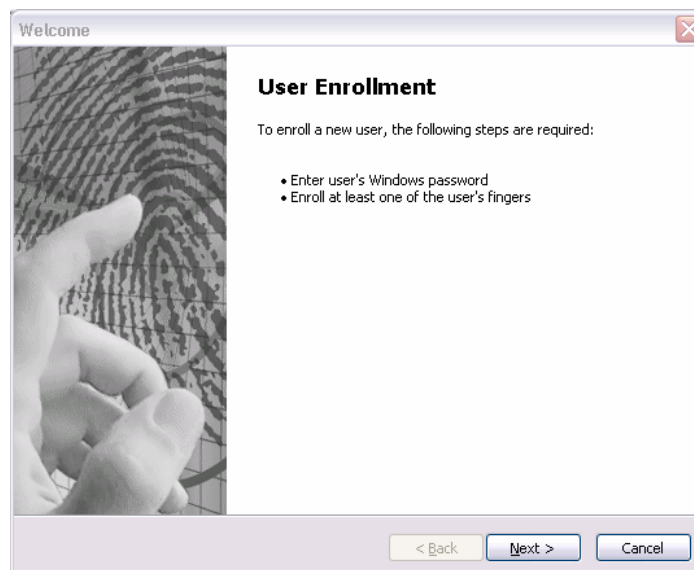

[User's Passport] appears in “Enter your password”. Click [Next].

When the finger print has been enrolled, [User's Password] appears. Slide your finger enrolled or type the password. Click [Next].

- 4 Type the Windows logon password in “Enter your password” and click [Next]. [User's Password] appears.

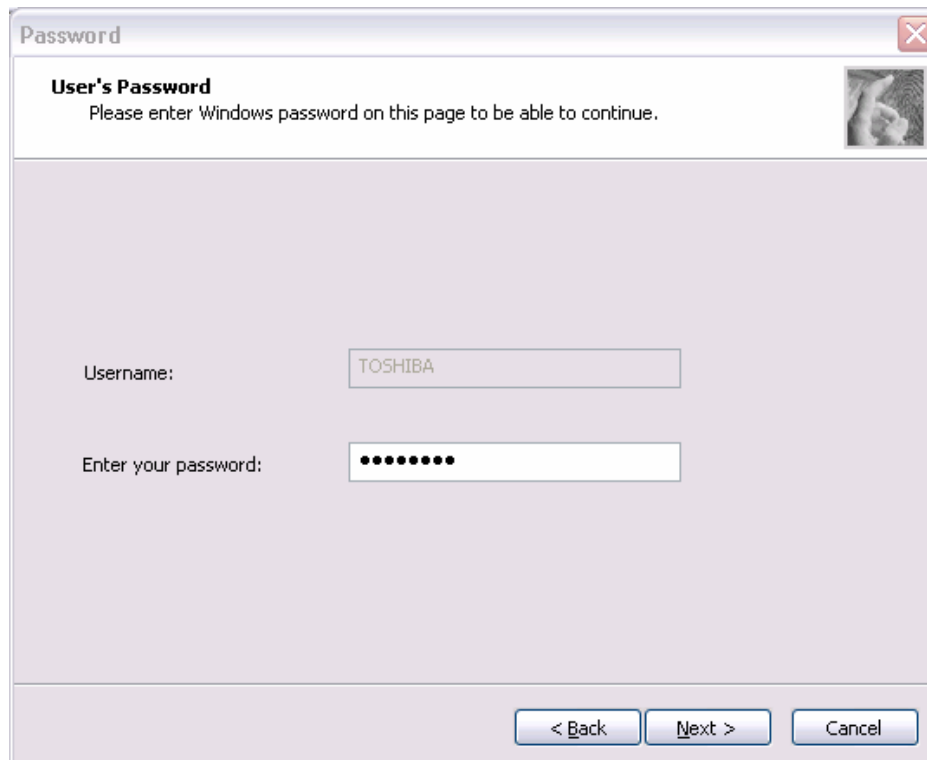

Password

User's Password
Please enter Windows password on this page to be able to continue.

Username: TOSHIBA

Enter your password: ●●●●●●●●●●

< Back Next > Cancel

- 5 Confirm that the box of [Run interactive tutorial] is checked (when proceeding with seeing Tutorial) and click [Next].

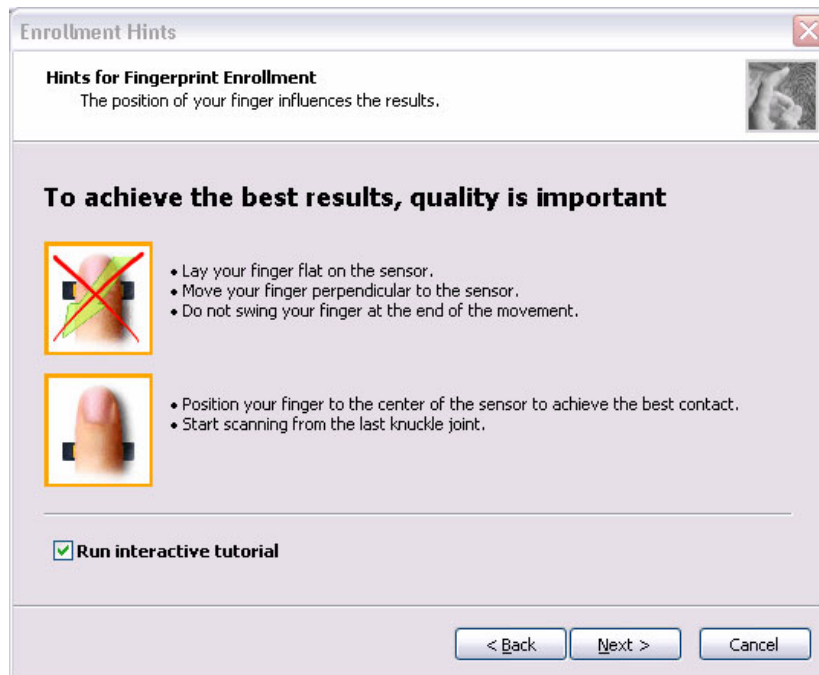

- 6 Watch the Video carefully, click [Next].

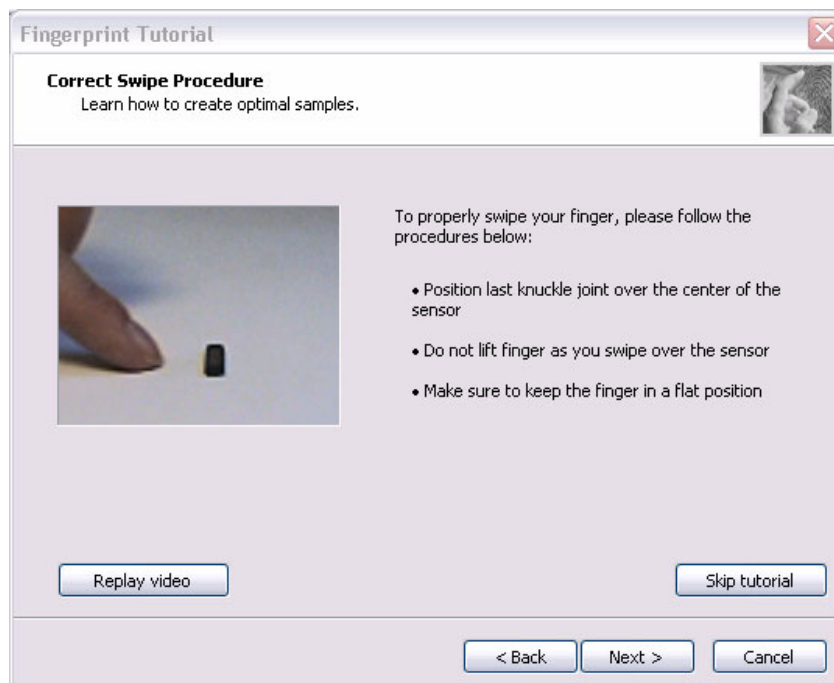

- Put lightly your finger on the fingerprint sensor at the right side of the touchpad and slide your finger toward you.

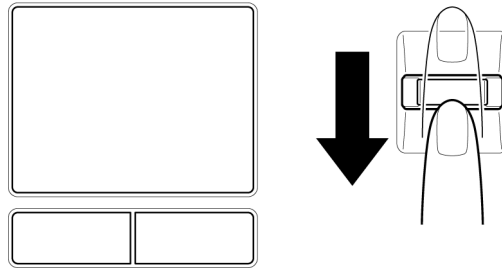

Slide your finger four times. Four boxes are filled with fingerprints. At this time, when you click the [Replay video], you can watch the video that you have watched in Procedure 6.

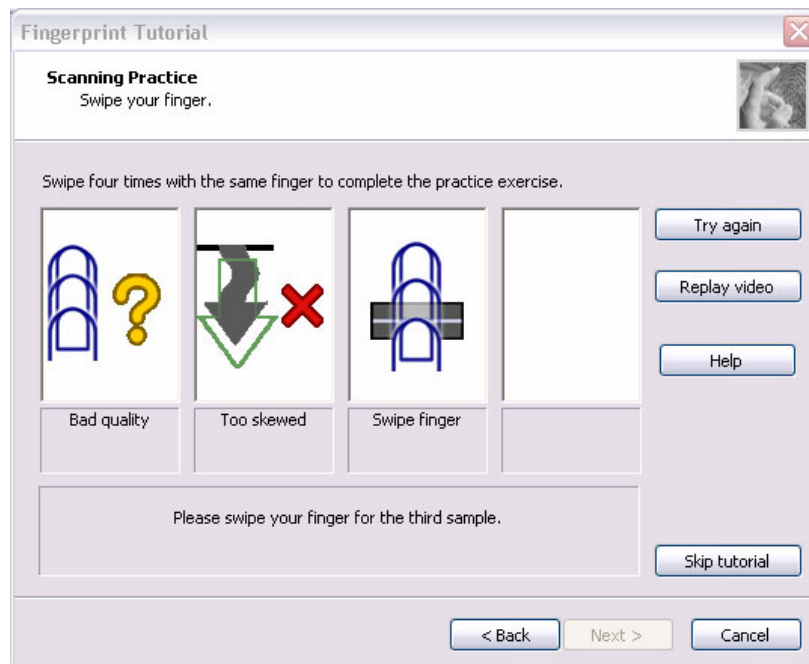

When you have failed in any time of four times reading and want to practice again, click [Try again]. When you have fully succeeded in four times of reading, the message of “Fully succeeded” appears.

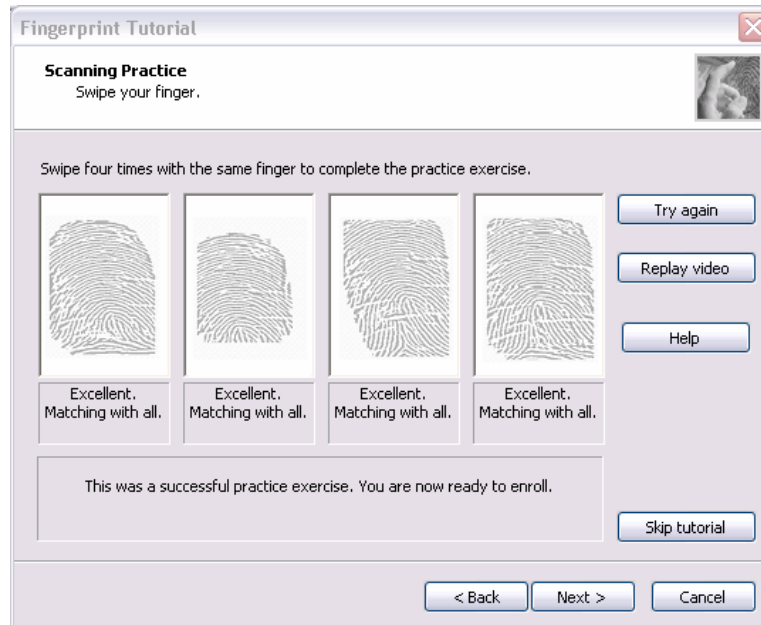

- 8 Click [Next]. The display of [User's Fingers]
- 9 Click the box you want to enroll.

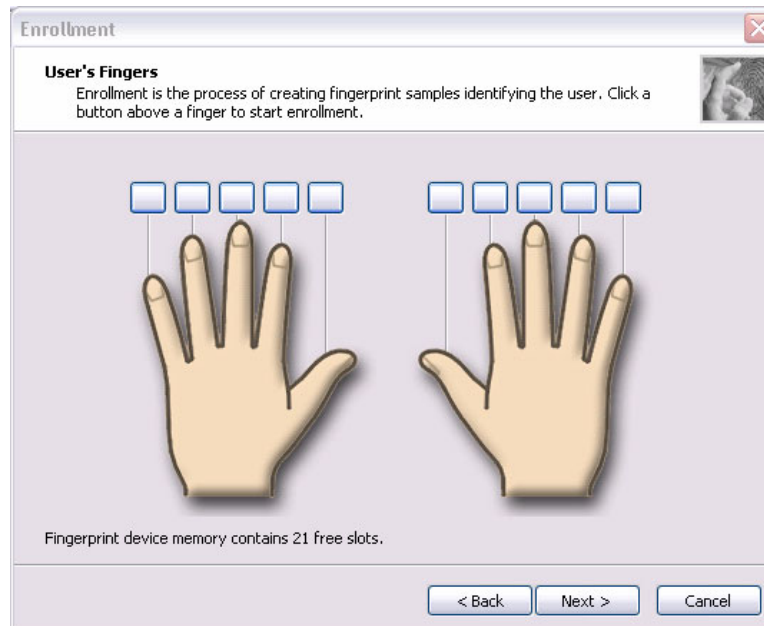

Put lightly the first joint of your finger you want to enroll on the fingerprint sensor and slide your finger toward you. Enroll your finger three times. Every time your finger has been successfully enrolled, one box is checked. When your finger has been successfully enrolled three times, the message of “Succeeded” appears.

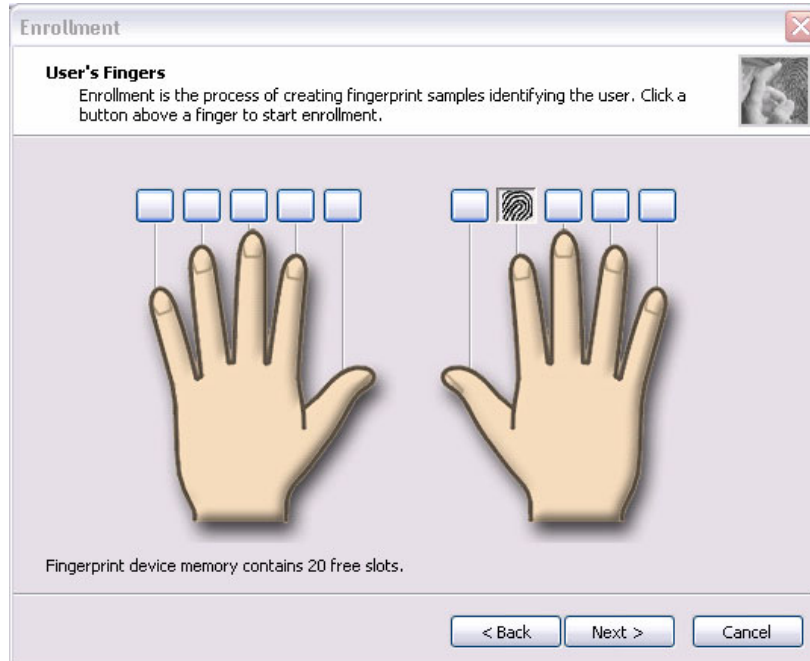

When you do not enroll your finger within two minutes after [User's Fingerprint] has been displayed, an error message appears. At the time, click [OK] and enroll your fingerprint.

When you attempt to enroll your finger that has been enrolled, you can not enroll. Enroll your other finger again.

- 10 Enroll another finger in Procedure 9. Enroll two fingers at least.
- 11 The display that recommend you to register a password.
- 12 Click [OK] in the following display.

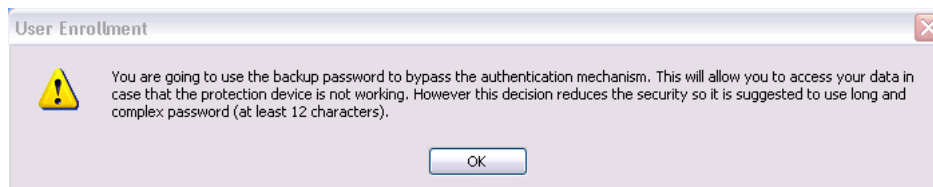

- 13 Type a backup password two times in the following display. (This password is different from the password of Windows logon.)



- 14 Click [Next]. The [Finish] display appears.

- 15 Click [Finish], “Welcome” display appears.

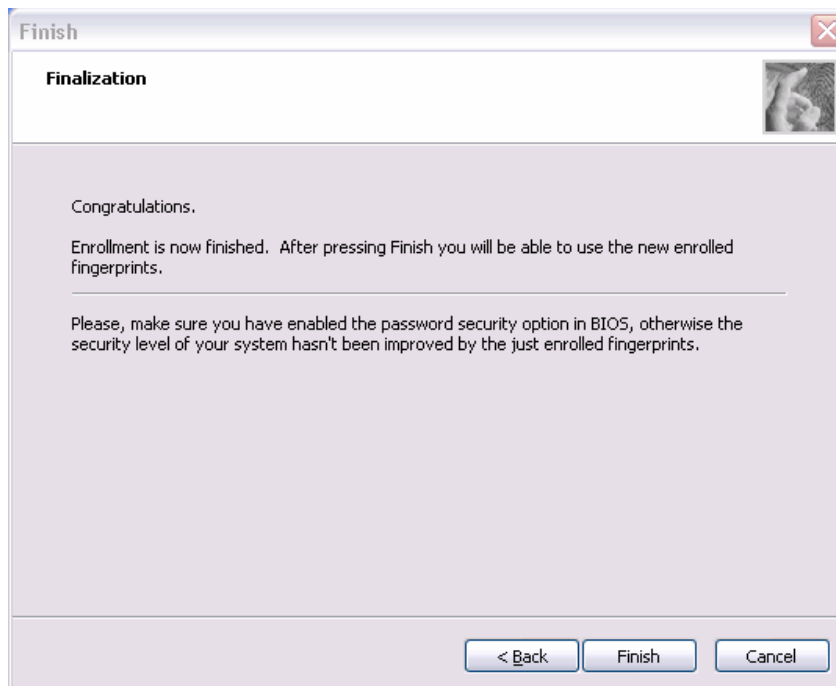

Procedure 3 Authentication of fingerprint

1. Turn on the computer to start up Windows.
2. In the Windows logon window, put lightly the first joint of your finger registered and slide your finger toward you.

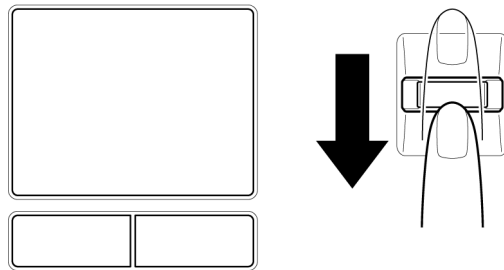

When authenticated, [Success] is displayed in the fingerprint authentication display.

When not authenticated well, warning message appears. If you fail continually ten times or more, you can not use the fingerprint authentication about one minute.

When not authenticated, type the password to logon to Windows.

Procedure 4 Connector Check and Replacement Check

The Fingerprint sensor cable is connected to the connector CN9550 on the Fingerprint sensor board and connector CN9520 on the system board.

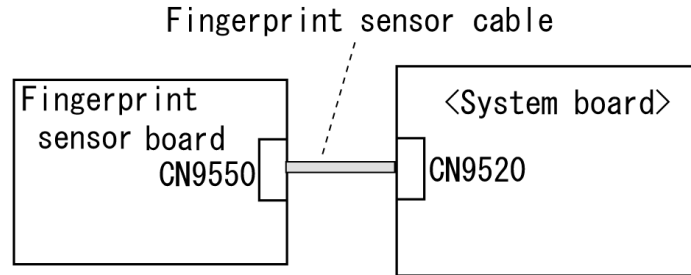

- Check 1 Check the Fingerprint sensor cable is firmly connected to the connector CN9550 on the Fingerprint sensor board and connector CN9520 on the system board. If not, connect it firmly. If the Fingerprint sensor is still not functioning properly, perform Check 2.
- Check 2 The Fingerprint sensor cable may be faulty. Replace it with a new one. If the problem persists, perform Check 3.
- Check 3 The Fingerprint sensor board may be faulty. Replace it with a new one. If the problem persists, perform Check 4.
- Check 4 The system board may be faulty. Replace it with a new one.

Chapter 3

Tests and Diagnostics

[CONFIDENTIAL]

Chapter 3 Contents

3.1	The Diagnostic Test	3-1
3.1.1	Diagnostics menu	3-1
3.1.2	H/W (Hardware) initial information setting tool.....	3-3
3.1.3	Heatrun test program.....	3-3
3.2	Executing the Diagnostic Test	3-4
3.2.1	Diagnostics menu (T&D).....	3-5
3.2.2	H/W initial information setting tool	3-8
3.2.3	Heatrun test program.....	3-8
3.3	Setting of the hardware configuration.....	3-9
3.4	Heatrun Test.....	3-11
3.5	Subtest Names.....	3-12
3.6	System Test.....	3-14
3.7	Memory Test.....	3-16
3.8	Keyboard Test.....	3-17
3.9	Display Test	3-18
3.10	Floppy Disk Test.....	3-21
3.11	Printer Test.....	3-23
3.12	Async Test	3-25
3.13	Hard Disk Test	3-26
3.14	Real Timer Test.....	3-29
3.15	NDP Test.....	3-31
3.16	Expansion Test.....	3-32
3.17	CD-ROM/DVD-ROM Test	3-34
3.18	Error Code and Error Status Names.....	3-35
3.19	Hard Disk Test Detail Status.....	3-38
3.20	ONLY ONE TEST.....	3-40
3.20.1	Program Description	3-40
3.20.2	Operations	3-40

3.21	Head Cleaning.....	3-47
	3.21.1 Function Description.....	3-47
	3.21.2 Operations.....	3-47
3.22	Log Utilities.....	3-48
	3.22.1 Function Description.....	3-48
	3.22.2 Operations.....	3-49
3.23	Running Test.....	3-50
	3.23.1 Function Description.....	3-50
	3.23.2 Operations.....	3-50
3.24	Floppy Disk Drive Utilities.....	3-51
	3.24.1 Function Description.....	3-51
	3.24.2 Operations.....	3-52
3.25	System Configuration.....	3-56
	3.25.1 Function Description.....	3-56
	3.25.2 Operations.....	3-57
3.26	Wireless LAN Test Program (Atheros).....	3-58
	3.26.1 Setting the responder machine.....	3-59
	3.26.2 Test procedure.....	3-60
	3.26.3 Contents of the test and errors.....	3-61
3.27	Wireless LAN Test Program (Intel-made a/b/g).....	3-65
3.28	LAN/Modem/Bluetooth/IEEE1394 Test Program.....	3-69
	3.27.1 LAN test.....	3-69
	3.27.2 Modem test.....	3-72
	3.27.3 Bluetooth test.....	3-73
	3.27.4 IEEE1394 test.....	3-83
3.29	Sound Test program.....	3-84
	3.29.1 Sound (Standard) test.....	3-84
	3.29.2 Sound (Legacy) test.....	3-86
	3.29.3 CD Sound (Standard) test.....	3-87
	3.29.4 CD Sound (Legacy) test.....	3-89

3.30 SETUP 3-90

 3.30.1 Function Description 3-90

 3.30.2 Accessing the SETUP Program..... 3-92

Tables

Table 3-1 Subtest names 3-12

Table 3-2 Error codes and error status names 3-35

Table 3-3 Hard disk controller status register contents 3-38

Table 3-4 Error register contents 3-39

Table 3-5 Error message..... 3-75

Table 3-6 Error code for Bluetooth test (BD_ADDR) 3-76

Table 3-7 Error code for Bluetooth test (BD_ADDR of the DUT)..... 3-80

Table 3-8 Common error code 3-82

3.1 The Diagnostic Test

This chapter explains how to use the Diagnostic Test programs to test the functions of the computer's hardware modules. The Diagnostics Programs are stored on some Diagnostic Disks. There are Service Program Modules (DIAGNOSTIC MENU) and the Test Program Modules (DIAGNOSTIC TEST MENU) on the Diagnostic Disk.

The Hardware Initial information Setting Tool consists of some programs which write the hardware information or displays the current information of the computer. It is also included in one of Diagnostic Disks.

The heatrun test is automatic test program which executes the some tests successively.

NOTE: Before starting the diagnostics, be sure to follow these steps:

1. Check all cables are connected firmly.
2. Exit any application and close Windows.
3. Check if [All Devices] is selected in the "Device Config." in SETUP menu.

3.1.1 Diagnostics menu

The DIAGNOSTIC MENU consists of the following functions.

- DIAGNOSTIC TEST
- ONLY ONE TEST
- HEAD CLEANING
- LOG UTILITIES
- RUNNING TEST
- FDD UTILITIES
- SYSTEM CONFIGURATION
- POWER OFF

The DIAGNOSTIC TEST MENU contains the following functional tests:

- SYSTEM TEST
- MEMORY TEST
- KEYBOARD TEST
- DISPLAY TEST
- FLOPPY DISK TEST
- PRINTER TEST
- ASYNC TEST
- HARD DISK TEST
- REAL TIMER TEST

- NDP TEST
- EXPANSION TEST
- CD-ROM/DVD-ROM TEST

Other tests are:

- Wireless LAN TEST (Wireless LAN TEST disk)
- LAN/Modem/Bluetooth/IEEE1394 TEST (LAN/Modem/Bluetooth/IEEE1394 TEST disk)
- Sound TEST (Sound TEST disk)

You will need the following equipment to perform some of the Diagnostic test programs.

- The Diagnostic Disks (T&D for maintenance for Main, LAN/Modem/Bluetooth/IEEE1394, wireless LAN and Sound)
- A formatted working disk (Floppy disk test)
- USB FDD (for all tests)
- A USB test module (USB test)
- A USB cable (USB test)
- An external CRT monitor (Expansion test)
- A CD test media TOSHIBA CD-ROM TEST DISK or ABEX TEST CD-ROM (Sound test)
- A DVD test media (DVD-ROM TEST DISK TSD-1) (Sound test)
- A music CD (Sound test)
- A store-bought CD-RW media (CD-ROM/DVD-ROM test)
- A microphone (Sound test)
- Headphones (Sound test)
- A cleaning kit to clean the floppy disk drive heads (Head Cleaning)
- An exclusive modem test jig (Nitto Electric Manufacture Co.,Ltd-made QE2000P01) (Modem test)
- A module cable and RJ11 connector checker (Modem test)
- A LAN wraparound connector (LAN test)
- PC card wraparound connector (Expansion test)
- A display with monitor ID function (Expansion test)
- RS232C wraparound connector (Async test)
- A PC for wraparound test (Wireless LAN test/Bluetooth test/IEEE1394 test)

3.1.2 H/W (Hardware) initial information setting tool

The H/W initial information setting tool consists of the following programs.

- Initial configuration
- DMI information save
- DMI information recovery
- System configuration display
- E2PROM test (MAC/GUID/DMI)

You will need the following equipment to perform some of the programs.

- The Diagnostics Disk (Main T&D)

3.1.3 Heatrun test program

The heatrun test starts automatically after the selection.

You will need the following equipment to perform this program.

- The Diagnostics Disk (Main T&D)

3.2 Executing the Diagnostic Test

To start the DIAGNOSTIC PROGRAM, follow these steps:

1. Insert the Diagnostics disk in the USB floppy disk drive.
2. Turn on the computer while pressing **U** key. The following menu appears.

```
TOSHIBA Diagnostics Startup Menu
```

```
-----  
(M) Main  
(I) Initial config set  
(H) Heatrun
```

```
Enter a choice: M
```

To start the Diagnostics menu (T&D), press **M** or **m** and **Enter**.

To start the H/W initial information setting tool, press **I** or **i** and **Enter**.

To start the Heatrun test, press **H** or **h** and **Enter**.

NOTE: When replacing the system board, it is necessary to execute the followings:

1. Before replacing, save the DMI information by executing subtest 03 DMI information save in 3.3 Setting of the hardware configuration.
2. Before replacing, apply the DMI information by executing subtest 04 DMI information recovery and subtest 08 System configuration in 3.3 Setting of the hardware configuration.

3.2.1 Diagnostics menu (T&D)

To execute this program, press **M** or **m** in the startup menu, press **Enter**. The following menu appears.

```
TOSHIBA personal computer XXXXXX DIAGNOSTICS
version X.XX (c) copyright TOSHIBA Corp. 20XX
```

```
DIAGNOSTICS MENU :
1 - DIAGNOSTIC TEST
2 - ONLY ONE TEST
3 -
4 - HEAD CLEANING
5 - LOG UTILITIES
6 - RUNNING TEST
7 - FDD UTILITIES
8 - SYSTEM CONFIGURATION
9 - POWER OFF
```

```
↑↓→← : Select items
Enter  : Specify
Esc    : Exit
```

NOTE: To exit the *DIAGNOSTIC TEST MENU*, press the **Esc** key. If a test program is in progress, press **Ctrl + Break** to exit the test program. If a test program is in progress, press **Ctrl + C** to stop the test program.

Set the highlight bar to **1**, and press **Enter**. The following DIAGNOSTIC TEST MENU will appear:

```
TOSHIBA personal computer XXXXXX DIAGNOSTICS
version X.XX (c) copyright TOSHIBA Corp. 20XX
```

```
DIAGNOSTIC TEST MENU :
```

```
1 - SYSTEM TEST
2 - MEMORY TEST
3 - KEYBOARD TEST
4 - DISPLAY TEST
5 - FLOPPY DISK TEST
6 - PRINTER TEST
7 - ASYNC TEST
8 - HARD DISK TEST
9 - REAL TIMER TEST
10 - NDP TEST
11 - EXPANSION TEST
12 - CD-ROM/DVD-ROM TEST
88 - ERROR RETRY COUNT SET [FDD & HDD]
99 - EXIT TO DIAGNOSTICS MENU
```

```
↑↓→← : Select items
Enter  : Specify
Esc    : Exit
```

Functions 1 through 12 are the Diagnostic Tests. Function 88 sets the floppy disk drive and hard disk drive error retry count (0-255).

To exit the submenu of the Diagnostic Test and returns to the Diagnostics Menu, set the highlight bar to function 99 and press **Enter**.

Select the option you want to execute and press **Enter**. When you select 1- SYSTEM TEST, the following message will appear:

```
SYSTEM TEST NAME      XXXXXX
```

<pre>xxxxxxx DIAGNOSTIC TEST VX.XX [Ctrl]+[Break] : test end [Ctrl]+[C] : key stop</pre>

```
SUB-TEST      : XX
PASS COUNT    : XXXXX      ERROR COUNT    : XXXXX
WRITE DATA   : XX         READ DATA    : XX
ADDRESS       : XXXXXX STATUS      : XXX
```

SUB-TEST MENU :

```
01 - ROM checksum
04 - Fan ON/OFF
05 - Geyserville
06 - Quick charge
07 - DMI read
99 - Exit to DIAGNOSTIC TEST MENU
```

```
↑↓→← : Select items
Enter : Specify
Esc   : Exit
```

NOTE: The menu displayed by your computer may be slightly different from the one shown above.

Select the desired subtest number from the subtest menu and press **Enter**. The following message will appear:

```
TEST LOOP : YES (or NO)
ERROR STOP : YES (or NO)
```

Use the right and left arrow keys to move the cursor to the desired option.

Selecting **YES** of TEST LOOP increases the pass counter by one, each time the test cycle ends and restarts the test cycle.

Selecting **NO** returns the process to the subtest menu after the test is complete.

Use the up and down arrow keys to move the cursor to "ERROR STOP".

Use the right and left arrow keys to move the cursor to the desired option and press **Enter**.

Selecting **YES** of ERROR STOP stops the test program when an error is found and displays the operation guide on the right side of the display screen as shown below:

```

ERROR STATUS NAME    [[ HALT OPERATION ]]

                        1: Test end
                        2: Continue
                        3: Retry

```

These three selections have the following functions respectively:

1. Terminates the test program and exits to the subtest menu.
2. Continues the test.
3. Restarts the test from the error.

Selecting **NO** keeps the test running even if an error is found. When an error occurred, the error status is displayed and one error is added to the error counter.

Table 3-1 in section 3.5 describes the function of each test on the subtest. Table 3-2 in section 3.18 describes the error codes and error status names for each error.

Details of tests in DIAGNOSTIC TEST MENU are described on and after section 3.6. As for other service programs, refer to section 3.20 to 3.25

3.2.2 H/W initial information setting tool

After selecting this test, the following menu appears in the display.

```

#####
#####      H/W initial information setting tool      VX.XX      #####
#####
*          1 ..... Initial configuration                *
*          3 ..... DMI information save                 *
*          4 ..... DMI information recovery             *
*          8 ..... System configuration display         *
*          9 ..... E2PROM test (MAC/GUID/DMI)          *
*****
... Press test number [1,3,4,8,9] ?

```

For more details on this test, refer to the section 3.3.

3.2.3 Heatrun test program

After selecting this test, the heatrun test starts executing the same subtest as 3.23 RUNNING TEST.

For more details on this test, refer to the section 3.4.

3.3 Setting of the hardware configuration

To execute this program, press **I** or **i** in the startup menu, press **Enter** and follow the directions on the screen. The H/W initial information setting tool consists of four subtests. Move the highlight bar to the subtest you want to execute and press **Enter**.

Subtest 01 Initial configuration

This subtest executes the following items and shows their contents in the display. When an item ends normally, the program proceeds automatically to the next one. When an error is found, the program stops and waits for key input. (After solving the problem, the program executes the item again.)

Setting of the CPU set table
Setting of the micro code
Setting of the EHSS
Inputting and writing of DMI information

When the DMI information is displayed, the following messages appear in order. Input each information. (If you do not replace the PCB, the DMI information should not be changed.)

1. "Enter Model Name ?" is displayed. Input the computer's model name and press **Enter**. (e.g. DynaBook)
2. "Enter Version Number ?" is displayed. Input the computer's version number and press **Enter**. (e.g. PC18070C313S)
3. "Enter Serial Number ?" is displayed. Input the computer's serial number and press **Enter**. (e.g. 12345678)
4. "Enter Model Number ?" is displayed. Input the computer's sales model number and press **Enter**. (e.g. PP200-AAAAA)
5. "Enter Bundle Number ?" is displayed. Input the computer's PCN/Bundle number and press **Enter**. (e.g. PMSREQ3Q34H/S0123456789)
6. "Write data OK (Y/N) ?" is displayed. To write the DMI information to the Flash ROM, press **Y**, and then **Enter**.
7. "Create DMIINFO TXT (Y/N) ?" is displayed. Press **Y**, then the DMI information (text data) is written to the Floppy disk, etc.

- Setting of the HWSC
- Setting of the UUID
- Display of the DMI information (including UUID)

After completion of the above settings, H/W configuration & DMI information are appeared in order. Check the contents and press **Enter**.

Subtest 03 DMI information save

This is one of tools to copy the DMI information to a new PCB after replacing.

This subtest saves all the DMI data in a floppy disk.

Subtest 04 DMI information recovery

This is one of tools to copy the DMI information to a new PCB after replacing.

This subtest writes all the DMI data in the floppy disk into the new PCB.

NOTE: *Since the data of UUID is updated every time when this subtest, DMI information recovery, is done, the saved UUID data is not written.*

Subtest 08 System configuration display

This subtest displays the information of the system configuration.

When the following message appears, confirm the contents and press **Enter**.

Press [Enter] key

For more details on the system configuration information, refer to “3.25 System configuration”.

Subtest 09 E2PROM test (MAC/GUID/DMI)

It checks whether the MAC address, GUID of IEEE1394 and DMI information are written.

3.4 Heatrun Test

To execute this program, press **H** or **h** in the startup menu, press **Enter**.

After selecting this test, the same subtests as 3.23 Running Test are executed successively.

For more details on the procedure and test content, refer to Running Test.

When the heatrun test ends normally, following message appears in the display.

```
*****  
HEATRUN NORMAL END  
*****  
Press any key to continue...
```

Press any key and return to the startup menu.

NOTE: *The test result (Errorlog.txt) is stored in the floppy disk. The result is displayed in the same format as Log Utilities. For more details of the format, refer to 3.22 Log Utilities.*

3.5 Subtest Names

Table 3-1 lists the subtest names for each test program in the DIAGNOSTIC TEST MENU.

Table 3-1 Subtest names (1/2)

No.	Test Name	Subtest No.	Subtest Name
1	SYSTEM	01	ROM checksum
		02	Fan ON/OFF
		03	Geyserville
		04	Quick charge
		05	DMI read
2	MEMORY	01	Conventional memory
		02	Protected Mode
		03	Protected Mode (cache off)
		04	Cache memory (on/off)
		05	Stress
3	KEYBOARD	01	Pressed key code display
4	DISPLAY	01	VRAM read/write for VGA
		02	Gradation for VGA
		03	Gradation for LCD
		04	Gradation & Mode test for VGA
		05	All dot on/off for LCD
		06	"H" pattern display
		07	LCD Brightness
5	FLOPPY DISK	01	Sequential read
		02	Sequential read/write
		03	Random address/data
		04	Write specified address
		05	Read specified address

Table 3-1 Subtest names (2/2)

No.	Test Name	Subtest No.	Subtest Name
6	PRINTER [Not supported]	01	Ripple pattern
		02	Function
		03	Wraparound
7	ASYNC [Not supported]	01	FIR/SIR Point to point (send)
		02	FIR/SIR Point to point (receive)
		03	Wraparound (board)
8	HARD DISK	01	Sequential read
		02	Address uniqueness
		03	Random address/data
		04	Cross talk & peak shift
		05	Partial Read
		06	Write specified address
		07	Read specified address
		08	Sequential write
		09	W-R-C specified address
9	REAL TIMER	01	Real time
		02	Backup memory
		03	Real time carry
10	NDP	01	NDP
11	EXPANSION	01	PCMCIA wraparound [Not supported]
		02	RGB monitor ID
12	CD-ROM /DVD-ROM	01	Sequential read
		02	Read specified address
		03	Random address/data
		04	RW 1point W/R/C

3.6 System Test

To execute the System Test, select **1** from the DIAGNOSTIC TEST MENU, press **Enter** and follow the directions on the screen. Move the highlight bar to the subtest you want to execute and press **Enter**.

Subtest 01 ROM checksum

This subtest executes a checksum test of the BIOS ROM (range: F0000h to FFFFFh, 64KB) on the System Board.

Subtest 02 Fan ON/OFF

The following message will appear.

```
Fan number select (1;FAN#1(CPU), 2;FAN#2(GPU)*1, 0; FAN#1&#2)?
```

To check the CPU fan, press **1** and **Enter**.

To check the GPU fan, press **2** and **Enter**.

To check both CPU fan and GPU fan, press **0** and **Enter**.

The following message will appear.

```
*** Test Fan Revolution 0000RPM start
```

Make sure the fan does not rotate, then press **Enter**.

The following message will appear.

```
*** Test Fan Revolution Low speed Start
```

Make sure the fan rotates at low speed, then press **Enter**.

The following message will appear.

```
*** Test Fan Revolution High speed Start
```

Make sure the fan rotates at high speed, then press **Enter**.

After a while, the fan rotating will stop.

*1 2;FAN#2(GPU) is not supported in this model.

Subtest 03 Geyserville

If the CPU supports Geyserville (SpeedStep), this subtest checks that the CPU operating clock speed can be changed.

Subtest 04 Quick charge

This subtest checks the status for the quick charge.

Subtest 05 DMI read

This subtest displays the information in the Flash-ROM in the following format.

```
*** DMI Data Display Ver X.XX ***  
Model Name       : XXXXXXXXXXXXX  
Version Number  : XXXXXXXXXXXXX  
Serial Number   : XXXXXXXXX  
Model Number    : XXXXXX-XXXXX  
UUID Number     : XXXXXXXXXXXXXXXXXXXXXXXXXXXXXXXXXXXXX  
Press [Enter] to EXIT
```

To exit this subtest and return to the SYSTEM test menu, press **Enter**.

3.7 Memory Test

To execute the Memory Test, select **2** from the DIAGNOSTIC TEST MENU, press **Enter** and follow the directions on the screen. Move the highlight bar to the subtest you want to execute and press **Enter**.

Subtest 01 Conventional memory

This subtest writes a constant data to conventional memory (0 to 640 KB), then reads the new data and compares the result with the original data.

Subtest 02 Protected Mode

NOTE: The *CONFIG.SYS* file must be configured without expanded memory manager programs such as *EMM386.EXE*, *EMM386.SYS* or *QEMM386.SYS*. Also, the *HIMEM.SYS* must be deleted from the *CONFIG.SYS* file.

This subtest writes constant data and address data (from 1MB to maximum MB), and reads the new data and compares the result with the original data.

Subtest 03 Protected Mode (cache off)

This subtest executes the same way as the subtest 02 with the cache off.

Subtest 04 Cache memory (on/off)

To test the cache memory, a pass-through write-read comparison of '5Ah' data is run repeatedly to the test area ('7000': 'Program' size to '7000': '7FFF' (32 KB)) to check the hit-miss ratio (on/off status) for CPU cache memory. One test takes 3 seconds.

Number of misses < Number of hits → OK

Number of misses ≥ Number of hits → Fail

Subtest 05 Stress

Write/Read buffer (1 size = B30h) is prepared in the conventional memory. The data is made in the Write Buffer, the data in Write Buffer is written in the area of address of 1MB or after. The data is red in the Read Buffer and data is compared in area up to the maximum size.

Data: FFh, FFh, FFh, FFh, FFh, 00h, 00h, 00h, 00h,
FFh, FFh, FFh, 00h, FFh, 00h, 00h, FFh, 00h,
00h, FFh, FFh, FFh, FFh, 00h, 00h, 00h, AAh

3.8 Keyboard Test

To execute the Keyboard Test, select **3** from the DIAGNOSTIC TEST MENU, press **Enter** and follow the directions on the screen. Move the highlight bar to the subtest you want to execute and press **Enter**.

Subtest 01 Pressed key code display

When a key is pressed, the scan code, character code, and key top name are displayed on the screen in the format shown below. The **Ins Lock, Caps Lock, Num Lock, Scroll Lock, Alt, Ctrl, Left Shift** and **Right Shift** keys are displayed in reverse screen mode when pressed. The scan codes, character codes, and key top names are shown in Appendix E.

```
KEYBOARD TEST  IN PROGRESS  302000
      Scan code      =
      Character code  =
      Keytop         =
Ins Lock  Caps Lock  Num Lock   Scroll Lock
Alt       Ctrl       Left Shift  Right Shift
PRESS [Enter] KEY
```

3.9 Display Test

To execute the Display Test, select **4** from the DIAGNOSTIC TEST MENU, press **Enter** and follow the directions on the screen. Move the highlight bar to the subtest you want to execute and press **Enter**.

Subtest 01 VRAM read/write for VGA

This subtest writes the constant data (AAh and 55h) to the video RAM. The data is read and compared to the original data.

Subtest 02 Gradation for VGA

This subtest displays four colors: red, green, blue and white from left to right across the screen from black to maximum brightness. The display below appears on the screen, when this subtest is executed.

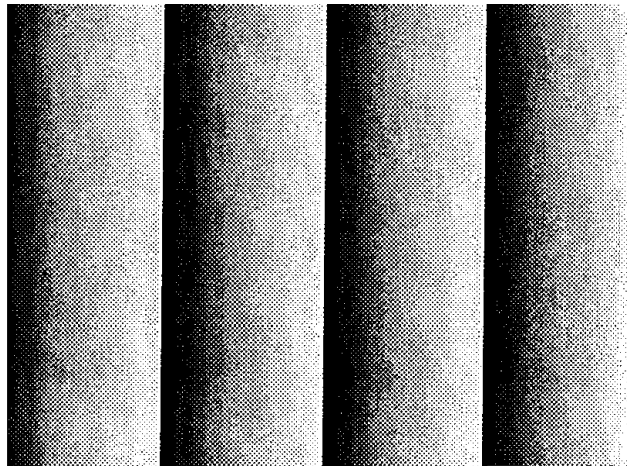

To exit this subtest and return to the DISPLAY TEST menu, press **Enter**.

Subtest 03 Gradation for LCD

This subtest displays bands of gradations for mixed colors, then for red, green, and blue. Next, it displays eight solid colors full screen: red, semi-red, green, semi-green, blue, semi-blue, white and semi-white. Each color displays for three seconds.

Subtest 04 Gradation & Mode test for VGA

This subtest displays gradations for following modes. To change the mode, press **Enter**.

```
[Mode 12]
[Mode 13]
[Mode 3]
[Mode 111  640*480  64K]
[Mode 112  640*480  16M]
[Mode 114  800*600  64K]
[Mode 115  800*600  16M]
[Mode 117 1024*768  64K]
[Mode 118 1024*768  16M]
```

The display below appears on the screen when this subtest is executed.

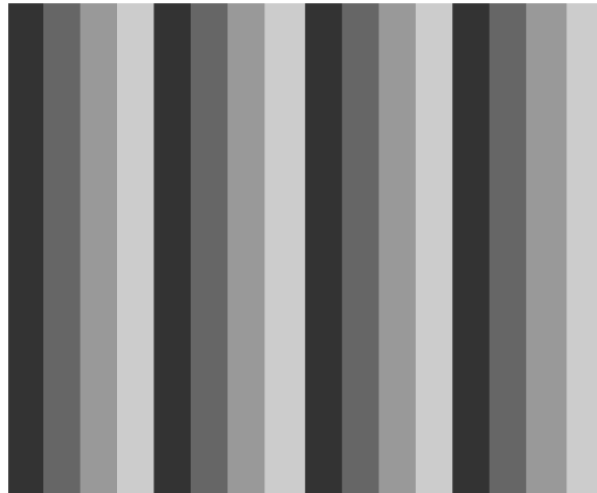

(Display example: Mode 12)

To exit this subtest and return to the DISPLAY TEST menu, press **Enter** after displaying the Mode 118.

Subtest 05 All dot on/off for LCD

This subtest displays an all-white screen then an all-black screen. The display changes automatically every three seconds and the screen returns to the DISPLAY TEST menu.

Subtest 06 “H” pattern display

This subtest displays a full screen of “H” patterns.

```

HHHHHHHHHHHHHHHHHHHHHHHHHHHHHHHHHHHHHHHHHHHHHHHHHHHHHHHHHHHHHHHH
HHHHHHHHHHHHHHHHHHHHHHHHHHHHHHHHHHHHHHHHHHHHHHHHHHHHHHHHHHHHHHHH
HHHHHHHHHHHHHHHHHHHHHHHHHHHHHHHHHHHHHHHHHHHHHHHHHHHHHHHHHHHHHHHH
HHHHHHHHHHHHHHHHHHHHHHHHHHHHHHHHHHHHHHHHHHHHHHHHHHHHHHHHHHHHHHHH
HHHHHHHHHHHHHHHHHHHHHHHHHHHHHHHHHHHHHHHHHHHHHHHHHHHHHHHHHHHHHHHH
HHHHHHHHHHHHHHHHHHHHHHHHHHHHHHHHHHHHHHHHHHHHHHHHHHHHHHHHHHHHHHHH
HHHHHHHHHHHHHHHHHHHHHHHHHHHHHHHHHHHHHHHHHHHHHHHHHHHHHHHHHHHHHHHH
HHHHHHHHHHHHHHHHHHHHHHHHHHHHHHHHHHHHHHHHHHHHHHHHHHHHHHHHHHHHHHHH
HHHHHHHHHHHHHHHHHHHHHHHHHHHHHHHHHHHHHHHHHHHHHHHHHHHHHHHHHHHHHHHH
HHHHHHHHHHHHHHHHHHHHHHHHHHHHHHHHHHHHHHHHHHHHHHHHHHHHHHHHHHHHHHHH
HHHHHHHHHHHHHHHHHHHHHHHHHHHHHHHHHHHHHHHHHHHHHHHHHHHHHHHHHHHHHHHH
HHHHHHHHHHHHHHHHHHHHHHHHHHHHHHHHHHHHHHHHHHHHHHHHHHHHHHHHHHHHHHHH
HHHHHHHHHHHHHHHHHHHHHHHHHHHHHHHHHHHHHHHHHHHHHHHHHHHHHHHHHHHHHHHH
HHHHHHHHHHHHHHHHHHHHHHHHHHHHHHHHHHHHHHHHHHHHHHHHHHHHHHHHHHHHHHHH
HHHHHHHHHHHHHHHHHHHHHHHHHHHHHHHHHHHHHHHHHHHHHHHHHHHHHHHHHHHHHHHH
HHHHHHHHHHHHHHHHHHHHHHHHHHHHHHHHHHHHHHHHHHHHHHHHHHHHHHHHHHHHHHHH
HHHHHHHHHHHHHHHHHHHHHHHHHHHHHHHHHHHHHHHHHHHHHHHHHHHHHHHHHHHHHHHH
HHHHHHHHHHHHHHHHHHHHHHHHHHHHHHHHHHHHHHHHHHHHHHHHHHHHHHHHHHHHHHHH
HHHHHHHHHHHHHHHHHHHHHHHHHHHHHHHHHHHHHHHHHHHHHHHHHHHHHHHHHHHHHHHH
HHHHHHHHHHHHHHHHHHHHHHHHHHHHHHHHHHHHHHHHHHHHHHHHHHHHHHHHHHHHHHHH
HHHHHHHHHHHHHHHHHHHHHHHHHHHHHHHHHHHHHHHHHHHHHHHHHHHHHHHHHHHHHHHH
HHHHHHHHHHHHHHHHHHHHHHHHHHHHHHHHHHHHHHHHHHHHHHHHHHHHHHHHHHHHHHHH

```

To exit this subtest and return to the DISPLAY TEST menu, press **Enter**.

NOTE: The last row may not be completely filled. This condition does not indicate an error.

Subtest 07 LCD Brightness

The LCD brightness changes in the following order:

Super-Bright → Bright → Semi-Bright → Bright → Super-Bright

After displaying with Super-Bright of LCD brightness, the screen returns to the DISPLAY TEST menu.

3.10 Floppy Disk Test

CAUTION: Before running the floppy disk test, prepare a formatted work disk. Remove the Diagnostics Disk and insert the work disk into the FDD because the contents of the floppy disk will be erased.

To execute the Floppy Disk Test, select **5** from the DIAGNOSTIC TEST MENU, press **Enter** and follow the directions displayed on the screen.

1. The following message will appear. Select the media mode and start track to be tested and press **Enter**.

```
Test start track      (Enter:0/dd:00-79) ?
```

2. The Floppy Disk test contains five subtests that test the FDD. The floppy disk test menu will appear after you select FDD test parameters.

```
FLOPPY DISK          XXXXXXXX
```

```
XXX DIAGNOSTIC TEST VX.XX
[Ctrl]+[Break] : test end
[Ctrl]+[C]     : key stop
```

```
SUB-TEST      : XX
PASS COUNT    : XXXXX      ERROR COUNT   : XXXXX
WRITE DATA   : XX         READ DATA    : XX
ADDRESS       : XXXXXXX STATUS           : XXX
```

```
SUB-TEST MENU :
```

```
01 - Sequential read
02 - Sequential read/write
03 - Random address/data
04 - Write specified address
05 - Read specified address
99 - Exit to DIAGNOSTIC TEST MENU
```

```
↑↓→← : Select items
Enter : Specify
Esc   : Exit
```

Select the number of the subtest you want to execute and press **Enter**. The following message will appear during the floppy disk test.

```
FLOPPY DISK  IN PROGRESS  XXXXXXXX  xxx DIAGNOSTIC TEST VX.XX
                                         [Ctrl]+[Break] : test end
                                         [Ctrl]+[C]   : key stop

SUB-TEST      : XX
PASS COUNT    : XXXXX      ERROR COUNT   : XXXXX
WRITE DATA   : XX         READ DATA    : XX
ADDRESS       : XXXXXXXX STATUS           : XXX
```

When the subtest 04 or 05 is selected, the following messages will appear on the screen. Select the test data (subtest 04 only), track number and head number you want to test.

```
Test data ?? (subtest 04 only)
Track No. ??
Head No.  ?
```

Subtest 01 Sequential read

This subtest performs a Cyclic Redundancy Check (CRC) that continuously reads all the tracks (track: 0 to 39/0 to 79) on a floppy disk.

Subtest 02 Sequential read/write

This subtest continuously writes data pattern B5ADADh to all the tracks (track: 0 to 39/0 to 79) on a floppy disk. The data is then read and compared to the original data.

Subtest 03 Random address/data

This subtest writes random data to random addresses on all tracks (track: 0 to 39/0 to 79) on a floppy disk. The data is then read and compared to the original data.

Subtest 04 Write specified address

This subtest writes the data specified by an operator to a specified track, head and address.

Subtest 05 Read specified address

This subtest reads data from a track, head and address specified by an operator.

3.11 Printer Test

NOTE: Printer Test is not supported for this model.

To execute the Printer Test, select **6** from the DIAGNOSTIC TEST MENU, press **Enter** and follow the directions on the screen.

NOTE: An IBM compatible printer must be connected to the system to execute this test. Also, printer port wraparound connector must be connected.

The following message will appear, after selecting the subtest 01 to 03 of the printer test:

```
channel#1 = XXXXh
channel#2 = XXXXh
channel#3 = XXXXh
```

Select the channel number (1-3) ?

The printer I/O port address is specified by the XXXXh number. The computer supports three printer channels. Select the printer channel number, and press **Enter** to execute the selected subtest.

Subtest 01 Ripple pattern

This subtest prints characters for codes 20h through 7Eh line-by-line while shifting one character to the left at the beginning of each new line.

```
! "$%&'()*+,-./0123456789:;<=>?@ABCDEFGHIJKLMNQRSTUvwxyz[\]^_`abcdefghijklmnop
! "$%&'()*+,-./0123456789:;<=>?@ABCDEFGHIJKLMNQRSTUvwxyz[\]^_`abcdefghijklmnop
"#$%&'()*+,-./0123456789:;<=>?@ABCDEFGHIJKLMNQRSTUvwxyz[\]^_`abcdefghijklmnopq
#$%&'()*+,-./0123456789:;<=>?@ABCDEFGHIJKLMNQRSTUvwxyz[\]^_`abcdefghijklmnopqr
#$%&'()*+,-./0123456789:;<=>?@ABCDEFGHIJKLMNQRSTUvwxyz[\]^_`abcdefghijklmnopqrs
%&'()*+,-./0123456789:;<=>?@ABCDEFGHIJKLMNQRSTUvwxyz[\]^_`abcdefghijklmnopqrst
E'()*+,-./0123456789:;<=>?@ABCDEFGHIJKLMNQRSTUvwxyz[\]^_`abcdefghijklmnopqrstu
'()*+,-./0123456789:;<=>?@ABCDEFGHIJKLMNQRSTUvwxyz[\]^_`abcdefghijklmnopqrstuv
()*+,-./0123456789:;<=>?@ABCDEFGHIJKLMNQRSTUvwxyz[\]^_`abcdefghijklmnopqrstuvw
) *+,-./0123456789:;<=>?@ABCDEFGHIJKLMNQRSTUvwxyz[\]^_`abcdefghijklmnopqrstuvwx
*+,-./0123456789:;<=>?@ABCDEFGHIJKLMNQRSTUvwxyz[\]^_`abcdefghijklmnopqrstuvwxy
```

Subtest 02 Function

This subtest is for IBM compatible printers, and tests the following functions:

Normal print
Double-width print
Compressed print
Emphasized print
Double-strike print
All characters print

This subtest prints the various print types shown below:

```
PRINTER TEST
1.  THIS LINE SHOWS NORMAL PRINT.
2.  THIS LINE SHOWS DOUBLE-WIDTH PRINT.
3.  THIS LINE SHOWS COMPRESSED PRINT.
4.  THIS LINE SHOWS EMPHASIZED PRINT.
5.  THIS LINE SHOWS DOUBLE-STRIKE PRINT.
6.  ALL CHARACTERS PRINT
   !"#$$%&'()*+,-./0123456789:;<=>?@ABCDEFGHIJKLMN OPQRSTUVWXYZ[\]^_`abcdefghijklmnop
opqrstuvwxyz{|}~
```

Subtest 03 Wraparound

NOTE: To execute this subtest, a printer wraparound connector must be connected to the computer's printer port.

This subtest checks the output and bi-directional modes of the data control and status lines through the parallel port wraparound connector (34M741986G01). (Both output and bi-directional modes are tested.)

3.12 Async Test

NOTE: Async Test is not supported for this model.

To execute the Async Test, select **7** from the DIAGNOSTIC TEST MENU, press **Enter** and follow the directions displayed on the screen. Move the highlight bar to the subtest you want to execute and press **Enter**.

Subtest 01 and 02 require the following data format:

Method : Asynchronous
Speed : 38400BPS
Data : 8 bits and one parity bit (EVEN)
Data pattern : 20h to 7Eh

Subtest 01 FIR/SIR point to point (send)

NOTE: To execute subtests 01 and 02, each computer must have access to the other computer's infrared port.

This subtest sends 20h through 7Eh data to the receive side, then receives the sent data and compares it to the original data through the FIR/SIR port.

Subtest 02 FIR/SIR point to point (receive)

This subtest is used with subtest 01 described above. This subtest receives the data from the send side, then sends the received data through the FIR/SIR port.

Subtest 03 Wraparound (board)

NOTE: To execute this subtest, a RS-232C wraparound connector must be connected to the RS-232C port.

This subtest checks the data send/receive function through the wraparound connector.

3.13 Hard Disk Test

To execute the Hard Disk Test, select **8** from the DIAGNOSTIC TEST MENU, press **Enter**, and follow the directions on the screen.

CAUTION: *The contents of the hard disk will be erased when subtest 02, 03, 04, 06, 08 or 09 is executed. Before running the test, the customer should transfer the contents of the hard disk to floppy disk or another hard disk. If the customer has not or can not perform the back-up, create back-up disks as described below.*

Check to see if the Microsoft Create System Disks Tools (MSCSD.EXE) still exists in the System Tools Folder. (This tool can be used only once.) If it exists, use it to back up the pre-installed software, then use the Backup utility in the System Tools folder to back up the entire disk, including the user's files.

Refer to the operating system instructions.

1. The following message appears for the error dump operation when a data compare error is detected. Select **1** or **2**.

Data compare error dump (1:no, 2:yes)

2. The following message appears for whether or not the HDC status is displayed on the screen. The HDC status is described in section 3.19. Select **1** or **2**.

Detail status display (1:no, 2:yes)

3. The Hard Disk Test message will appear after you respond to the Detail Status prompt. Select the number of the subtest you want to execute and press Enter. The following message will appear during each subtest.

HARD DISK TEST XXXXXXXX

XXX DIAGNOSTIC TEST VX.XX [Ctrl]+[Break] : test end [Ctrl]+[C] : key stop

SUB TEST	:	XX			
PASS COUNT	:	XXXXX	ERROR COUNT	:	XXXXX
WRITE DATA	:	XX	READ DATA	:	XX
ADDRESS	:	XXXXXX	STATUS	:	XXX

The first three digits of the ADDRESS indicate which cylinder is being tested, the fourth digit indicates the head number and the last two digits indicate the sector number.

The first digit of the STATUS indicates the drive being tested and the last two digits indicate the error status code as explained in the table 3-2 of the section 3.18.

Subtest 01 Sequential read

This subtest is a sequential reading of all the tracks on the HDD starting at track 0. When all the tracks on the HDD have been read, the test starts at the maximum track and reads the tracks on the HDD sequentially back to track 0.

Subtest 02 Address uniqueness

This subtest writes unique address data to each sector of the HDD track-by-track. The data written to each sector is then read and compared with the original data. There are three ways the HDD can be read:

1. Forward sequential
2. Reverse sequential
3. Random

Subtest 03 Random address/data

This subtest writes random data in a random length to random addresses. This data is then read and compared to the original data.

Subtest 04 Cross talk & peak shift

This subtest writes eight types of worst pattern data (listed below) to a cylinder and then reads the data while moving from cylinder to cylinder. (Tests the data interference in the neighbor track.)

Worst pattern data	Cylinder
'B5ADAD'	0 cylinder
'4A5252'	1 cylinder
'EB6DB6'	2 cylinder
'149749'	3 cylinder
'63B63B'	4 cylinder
'9C49C4'	5 cylinder
'2DB6DB'	6 cylinder
'D24974'	7 cylinder

Subtest 05 Partial Read

This subtest reads 1GB data which is in minimum, middle and maximum address of the HDD area.

Subtest 06 Write specified address

This subtest writes specified data to a specified cylinder and head on the HDD.

Subtest 07 Read specified address

This subtest reads data, which has been written to a specified cylinder and head on the HDD.

Subtest 08 Sequential write

This subtest writes specified 2-byte data to all of the cylinders on the HDD.

Subtest 09 W-R-C specified address

This subtest writes data to a specified cylinder and head on the HDD, then reads the data and compares it to the original data.

3.14 Real Timer Test

To execute the Real Timer Test, select **9** from the DIAGNOSTIC TEST MENU, press **Enter** and follow the directions on the screen. Move the highlight bar to the subtest you want to execute and press **Enter**.

Subtest 01 Real time

A new date and time can be input during this subtest. To execute the real time subtest, follow these steps:

1. Select subtest 01 and the following messages will appear:

```
Current date : XX-XX-XXXX
Current time : XX:XX:XX
```

```
Enter new date:
```

```
PRESS [ENTER] KEY TO EXIT TEST
```

2. If the current date is not correct, input the correct date at the “Enter new date” prompt and press **Enter**.

3. The following messages will appear:

```
Current date : XX-XX-XXXX
Current time : XX:XX:XX
```

```
Enter new time:
```

```
PRESS [ENTER] KEY TO EXIT TEST
```

4. If the current time is not correct, input the correct time in 24-hour format. To enter “:”, press **Shift + ;**. The time is updated.

To exit the test, press **Enter**.

Subtest 02 Backup memory

This subtest checks the following backup memories:

Writes 1-bit of “on” data (01h through 80h) to address 0Eh through 7Fh

Writes 1-bit of “off” data (FEh through 7Fh) to address 0Eh through 7Fh

Writes the data pattern AAh and 55h to the address 0Eh to 7Fh

Then the subtest reads and compares this data with the original data.

Subtest 03 Real time carry

CAUTION: *When this subtest is executed, the current date and time are erased.*

This subtest checks the real time clock increments, making sure the date and time are displayed in the following format:

```
Current date : 12-31-1999
Current time : 23:59:58
```

The real time increments are automatically executed and the following is displayed:

```
Current date : 01-01-2000
Current time : 00:00:00
```

```
PRESS [Enter] KEY TO EXIT TEST
```

To exit the test, press **Enter**.

3.15 NDP Test

To execute the NDP test, select **10** from the DIAGNOSTICS TEST MENU, press **Enter** and follow the directions on the screen.

Subtest 01 NDP

This test checks the following functions of NDP:

- Control word
- Status word
- Bus
- Addition
- Multiplication

3.16 Expansion Test

To execute the expansion test, select **11** from the DIAGNOSTICS TEST MENU, press **Enter** and follow the directions on the screen.

Subtest 01 PCMCIA wraparound

CAUTION: PCMCIA wraparound test is not supported for this model.

NOTE: To execute this subtest, the PC card wraparound connector is required.

This subtest checks the following signal line of the PC card slot:

- Address line
- REG#, CE#1, CE#2 line
- Data line
- Speaker line
- Wait line
- BSY#, BVD1 line

This subtest is executed in the following order:

Sub#	Address	Good	Bad	Contents
01	00001 00001	nn nn	xx xx	Address line REG#, CE#1, CE#2 nn=A0, 90, 80, 00
02	00002	ww	rr	Data line ww=write data, rr=read data
03	00003	—	—	Speaker line
04	00004	40,80	xx	Wait line (40<xx<80)
05	00005	nn	xx	Other lines (BSY#, BVD1) NN=21, 00

NOTE: Select the subtest number 01, The following message will appear:
Test slot number select (1:slot0, 2:slot1, 0:slot0&1)?

Subtest 02 RGB monitor ID

NOTE: To execute this subtest, an external monitor with monitor ID function is required.

Connect the external monitor to the PC for the test of ID acquisition.

The judgment of acquisition is based on the panel data. In simultaneous display mode or internal display mode, in which the panel data is acquired, this subtest will fail. Therefore, make sure only the external display is selected when executing this subtest.

3.17 CD-ROM/DVD-ROM Test

To execute the CD-ROM/DVD-ROM test, select **12** from the DIAGNOSTICS TEST MENU, press **Enter** and follow the directions on the screen.

NOTE: For the subtest 01, 02 and 03, use the TOSHIBA CD-ROM TEST DISK TDY-01 or ABEX TEST CD-ROM TCDR-702 and DVD-ROM TEST DISK TSD-1. For the subtest 04, use a CD-RW on the market.

Subtest 01 Sequential read

This subtest is a sequential reading of one-block units (2K bytes) of all the logical addresses.

Subtest 02 Read specified address

This subtest reads one-block data from a specified address.

Subtest 03 Random address/data

This subtest reads one-block data and multi-block data from random addresses 200 times.

Subtest 04 RW 1point W/R/C

This subtest writes, reads and compares data at one point on a CD/RW media.

3.18 Error Code and Error Status Names

Table 3-2 lists the error codes and error status names for the DIAGNOSTIC TEST.

Table 3-2 Error codes and error status names (1/3)

Device name	Error code	Error status name
(Common)	FF	Data Compare Error
System	01 03 04 05 06 07 08 09 10	ROM - CHECKSUM ERROR ROM - SERIAL ID WRITE ERROR ROM - NOT SUPPORTED PS-SYSTEM ROM - SENSING ERROR(AC-ADAPT) ROM - SENSING ERROR(1st Batt) ROM - SENSING ERROR(2nd Batt) ROM - THORMISTOR ERROR(1) ROM - THORMISTOR ERROR(2) ROM - THORMISTOR ERROR(3)
Memory	01 02 DD	RAM - PARITY ERROR RAM - PROTECTED MODE NO CHANGE' RAM - CACHE MEMORY ERROR
Keyboard	FE FD F0 F1 F2 F3 F4 F5 F6 F7 F8 F9 FA EF ED	USB - GET DESCR.ERROR (FIRST) USB - SET ADDRESS ERROR HUB - GET DESCR.ERROR(Top 8B) HUB - GET DESCR.ERROR (Whole) HUB - SET CONFIGURATION ERROR HUB - GET DESCR.ERROR(DESCR.) HUB - SET FEATURE ERROR(P ON) HUB - GET STATUS ERROR HUB - SET FEATURE ERROR(RESET) HUB - CLEAR FEATURE ERROR HUB - CLEAR FEATURE1 ERROR HUB - SET FEATURE ERROR(Enab.) HUB - CLEAR FEATURE2 ERROR USB - OVER CURRENT ERROR USB - GET DESCR.ERROR(SECOND)
Display	EE	VRAM SIZE NOT SUPPORT

Table 3-2 Error codes and error status names (2/3)

Device name	Error code	Error status name
FDD	01 02 03 04 08 09 10 20 40 80 60 06 EE	FDD - BAD COMMAND ERROR FDD - ADDRESS MARK NOT FOUND FDD - WRITE PROTECTED FDD - RECORD NOT FOUND FDD - DMA OVERRUN ERROR FDD - DMA BOUNDARY ERROR FDD - CRC ERROR FDD - FDC ERROR FDD - SEEK ERROR FDD - TIME OUT ERROR FDD - NOT DRIVE ERROR FDD - MEDIA REMOVED FDD - WRITE BUFFER ERROR
Printer	01 08 10 20 40 80	PRT - TIME OUT PRT - FAULT PRT - SELECT LINE PRT - OUT OF PAPER PRT - POWER OFF PRT - BUSY LINE
ASYNC	01 02 04 08 10 20 40 80 88 05 06	RS232C - [DTR ON] TIME OUT RS232C - [CTS ON] TIME OUT RS232C - [RX READY] TIME OUT RS232C - [TX FULL] TIME OUT RS232C - PARITY ERROR RS232C - FRAMING ERROR RS232C - OVERRUN ERROR RS232C - LINE STATUS ERROR RS232C - MODEM STATUS ERROR SIR - TIME OUT ERROR FIR - TIME OUT ERROR
HDD	05 07 09 0B BB 08 01 02 04 10 20 40 80 11 AA	HDD - HDC NOT RESET ERROR HDD - DRIVE NOT INITIALIZE HDD - DMA BOUNDARY ERROR HDD - BAD TRACK ERROR HDD - UNDEFINED ERROR HDD - OVERRUN ERROR (DRQ ON) HDD - BAD COMMAND ERROR HDD - ADDRESS MARK NOT FOUND HDD - RECORD NOT FOUND ERROR HDD - ECC ERROR HDD - HDC ERROR HDD - SEEK ERROR HDD - TIME OUT ERROR HDD - ECC RECOVER ENABLE HDD - DRIVE NOT READY

Table 3-2 Error codes and error status names (3/3)

Device name	Error code	Error status name
(HDD)	CC E0 0A EE DA 12	HDD - WRITE FAULT HDD - STATUS ERROR HDD - BAD SECTOR HDD - ACCESS TIME ERROR HDD - NO HDD HDD - DMA CRC ERROR
NDP	01 02 03 04 05 06	NDP - NO CO-PROCESSOR NDP - CONTROL WORD ERROR NDP - STATUS WORD ERROR NDP - BUS ERROR NDP - ADDITION ERROR NDP - MULTIPLAY ERROR
EXPANSION	C1 C3 C4 C5 C6 C7 C8 CB CC CE CF	ADDRESS LINE ERROR CE#1 LINE ERROR CE#2 LINE ERROR DATA LINE ERROR WAIT LINE ERROR BSY# LINE ERROR BVD1 LINE ERROR ZV-Port ERROR NO PCMCIA CARD TYPE ERROR ZV_CONT# ERROR
CD-ROM /DVD-ROM	01 02 03 04 05 06 09 11 20 40 80 90 B0	BAD COMMAND ILLEGAL LENGTH UNIT ATTENTION MEDIA CHANGE REQUEST MEDIA DETECTED ADDITIMAL SENSE BOUNDARY ERROR CORRECTED DATA ERROR DRIVE NOT READY SEEK ERROR TIME OUT RESET ERROR ADDRESS ERROR

3.19 Hard Disk Test Detail Status

When an error occurs in the hard disk test, the following message is displayed:

```
HDC status = XXXXXXXX
```

Detailed information about the hard disk test error is displayed on the screen by an eight-digit number. The first four digits represent the hard disk controller (HDC) error status number and the last four digits are not used.

The hard disk controller error status is composed of two bytes; the first byte displays the contents of the HDC status register in hexadecimal form and the second byte displays the HDC error register.

The contents of the HDC status register and error register are listed in Tables 3-3 and 3-4.

Table 3-3 Hard disk controller status register contents

Bit	Name	Description
7	BSY (Busy)	"0" ... HDC is ready. "1" ... HDC is busy.
6	DRY (Drive ready)	"0" ... Hard disk drive is not ready to accept any command. "1" ... Hard disk drive is ready.
5	DWF (Drive write fault)	"0" ... DWF error is not detected. "1" ... Write fault condition occurred.
4	DSC (Drive seek complete)	"0" ... The hard disk drive heads are not settled over a track. "1" ... The hard disk drive heads are settled over a track.
3	DRQ (Data request)	"0" ... Drive is not ready for data transfer. "1" ... Drive is ready for data transfer.
2	COR (Corrected data)	"0" ... Not used "1" ... Correctable data error is corrected.
1	IDX (Index)	"0" ... Not used "1" ... Index is sensed.
0	ERR (Error)	"0" ... Normal "1" ... The previous command was terminated with an error.

Table 3-4 Error register contents

Bit	Name	Description
7	BBK (Bad block mark)	"0" ... Not used. "1" ... A bad block mark is detected.
6	UNC (Uncorrectable)	"0" ... There is no uncorrectable data error. "1" ... Uncorrectable data error has been detected.
5	—	Not used.
4	IDN (Identification)	"0" ... Not used. "1" ... There is no ID field in the requested sector.
3	—	Not used
2	ABT (Abort)	"0" ... Not used. "1" ... Illegal command error or command abort.
1	TK0 (Track 0)	"0" ... The hard disk found track 0 during a recalibrate command. "1" ... The hard disk could not find track 0 during a recalibrate command.
0	—	Not used.

3.20 ONLY ONE TEST

3.20.1 Program Description

This program tests the unique functions of this model.

3.20.2 Operations

Select test **2** from the DIAGNOSTIC MENU and press **Enter**. The following menu appears in the display.

```
#####
#####          ONLY ONE TEST Menu (XXXXXXXX)          #####
#####
*
*  1 .....      Pressed Key Display                      *
*  2 .....      Touch Pad                                *
*  3 .....      GP Button                                  *
*  4 .....      Wireless communication switch             *
*  5 .....      USB                                       *
*  6 .....      LED                                       *
*  A .....      Acceleration sensor                       *
*
*  9 .....      Exit to Common Test                       *
*
*****
.... Press test number [1-A] ?
```

Select the subtest number you want to test and press **Enter**.

To return to the DIAGNOSTIC TEST menu, select **9** and press **Enter**.

Subtest 01 Pressed key display

When you execute this subtest, the keyboard layout is drawn on the display as shown below. When any key is pressed, the corresponding key on the screen changes to the key character that was pressed. Holding a key down enables the auto-repeat function that causes the key's display character to blink.

Press **Del + Enter** to end the test.

<<<<<< Press Key Display >>>>>>

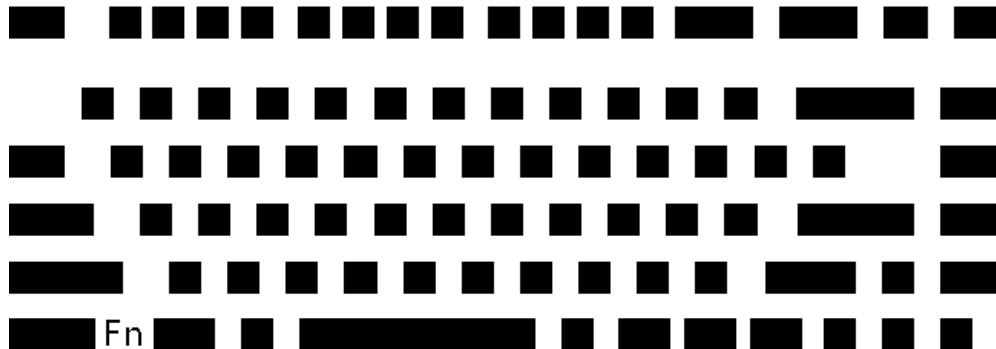

IF TEST OK, Press [Del] [Enter] key



Subtest 02 Touch Pad

This subtest checks the functions of the touch pad as shown below.

- A) Direction and parameter
- B) Switching function check.

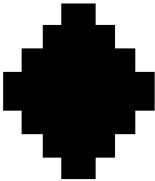

This test displays the response from the touch pad and touch pad switch. When moving your finger on the touch pad towards the upper left, the <POINTING> display changes according to the following illustration. If a touch pad switch is pressed, the <BUTTONS> displays appear on the right side one by one. The parameters appear above the <BUTTONS> (1) or (2) corresponding to the pressed touch pad switch highlights. To end this subtest, press two touch pad switches at the same time.

```

*** IPS TEST PROGRAM (Vx.xx) ***
<POINTING>                <PARAMETER>
                            STATUS:0000h
                            X-RATE:0000h
                            Y-RATE:0000H

                            <BUTTON>
                            (1)   (2)

<< PRESS BUTTON1+BUTTON2 THEN END >>

```

```

*** IPS TEST PROGRAM (Vx.xx) .***
< POINTING >              <PARAMETER>
                            STATUS:0018h
                            X-RATE:OK
                            Y-RATE:OK

                            <BUTTON>
                            (1)   (2)

<< PRESS BUTTON1+BUTTON2 THEN END >>

```

Subtest 03 GP Button

This subtest checks the operation of the front operation panel button.

Press the Internet button after the following message appears.

Press [Internet] button

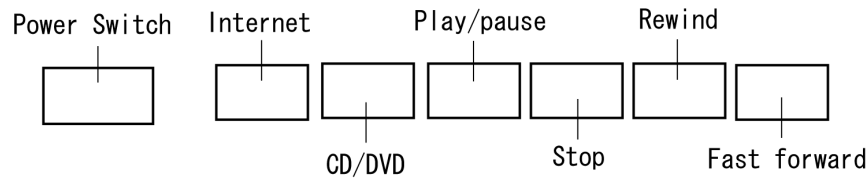

If the correct button is pressed, the following message appears.

Press [CD/DVD] button

If the correct button is pressed, the following message appears.

Press [Play/pause] button

If the correct button is pressed, the following message appears.

Press [Stop] button

If the correct button is pressed, the following message appears.

Press [Rewind] button

If the correct button is pressed, the following message appears.

Press [Fforward] button

If the correct button is pressed, the display returns to the ONLY ONE TEST menu.

Subtest 04 Wireless communication switch

This subtest checks if the Wireless communication switch works properly.

If the test is started with the switch ON, following message appears in the display.

Wireless communication switch is set to a start position (OFF)

Slide the switch to OFF position. Then, following message appears in the display.

Wireless communication switch ON !!

Slide the switch to ON position. Then, following message appears in the display.

Wireless communication switch OFF !!

After Sliding the switch to OFF position, return to the ONLY ONE TEST menu automatically.

Subtest 05 USB

NOTE: When executing this subtest, USB test module and USB cable must be connected.

This subtest checks if USB port works properly.

The following menu appears in the display.

```
#####
##### ONLY ONE TEST Menu (XXXXXXXX) #####
#####
*
* 0 ..... Port 0 (Left side) *
* 1 ..... Port 1 (Right side Upper) *
* 9 ..... EXIT 2 (Right side Lower) *
*
*****
.... Press test number[0-1, 9] ?
```

Connect the USB test module and USB cable to the computer.

Input the port test number and press **Enter**.

OK message appears in the display if the test ends without fail.

NG message appears in the display if an error is found during the test.

Confirm the connection of cable, and then execute the test again.

Press **9** and **Enter** to return to ONLY ONE TEST menu.

Subtest 06 LED

This subtest checks if each LED lights properly.

The following message appears in the display in order. Follow the instructions in the display to execute the test.

```
[HDD Access LED test]
```

Press any key and following message appears in the display.

```
[Caps/Num/Overlay BT/W-LAN LED test]
```

- (1) Press [Caps Lock] key ! ...Caps (on/off)
- (2) Press [Fn + F10] key ! ...Arrow (on/off)
- (3) Press [Fn + F11] key ! ...Num (on/off)
- (4) Slide [BT/W-LAN switch L&R]! (on/off)

Confirm corresponding LED lights properly.

Press **Enter** and following message appears in the display.

```
Check [DC-IN]&[Power]&[Main Battery]LED= Green
```

Check if the color of the message changes blue to green alternately.

Press **Enter** and return to the ONLY ONE TEST menu.

Subtest 0A Acceleration sensor

This subtest detects and corrects the each axis (X, Y, Z).

NOTE: Make sure that this subtest is executed on the following condition:

1. Flat desk with vertical plane to get the stability of machine.
2. The vertical wall or plane is necessary.
3. Prevent the machine from shake or shock.

<Example>

Set the machine
against the vertical plane
with the Front upward

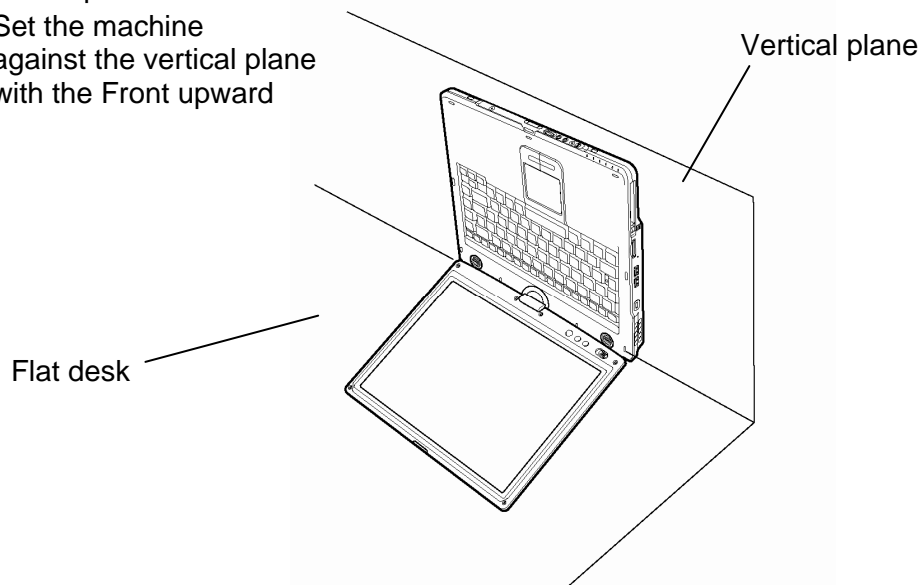

The figure below shows the name and position of each side.

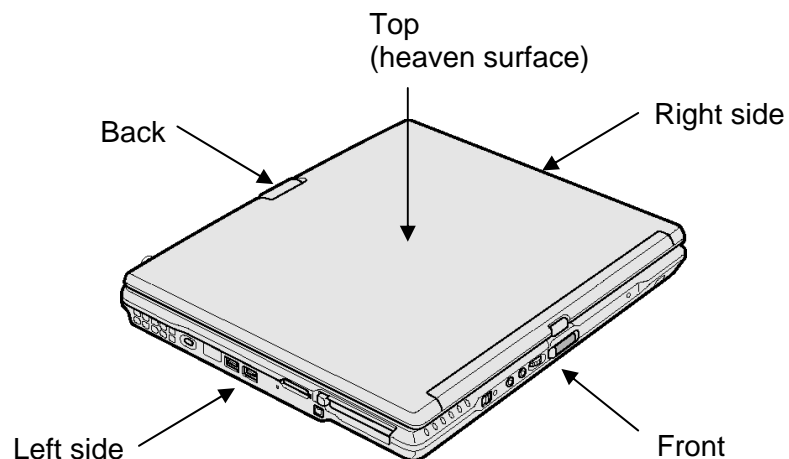

When this subtest is selected, the following message appears in the display.

The heaven surface establishes in the upper direction
Press [Enter] key

NOTE: Be sure to execute the test with the display panel opened.

Set the machine on the flat desk. Then press **Enter** to detect the data on this setting of machine. The following message appears in the display.

The back establishes in the upper direction
Press [Enter] key

Set the machine against the vertical plane on the flat desk with the back of machine upward. Then press **Enter** to detect the data on this setting of machine. The following message appears in the display.

The right establishes in the upper direction
Press [Enter] key

Set the machine against the vertical plane on the flat desk with the right side of machine upward. Then press **Enter** to detect the data on this setting of machine. The following message appears in the display.

The front establishes in the upper direction
Press [Enter] key

Set the machine against the vertical plane on the flat desk with the front of machine upward. Then press **Enter** to detect the data on this setting of machine. The following message appears in the display.

The left establishes in the upper direction
Press [Enter] key

Set the machine against the vertical plane on the flat desk with the left side of machine upward. Then press **Enter** to detect the data on this setting of machine.

When there is no defective during the all checks above, the following message appears in the display. Then press **Enter** and return to the Only One Test menu.

** Setting OK! **
Press [Enter] key

When any trouble in the above setting is found, the following message appears and the test halts. Then press **Enter** and return to the Only One Test menu.

** Setting ERROR! **
Press [Enter] key

3.21 Head Cleaning

3.21.1 Function Description

This function cleans the heads in the FDD by executing a series of head load/seek and read operations. A cleaning kit is necessary to perform this program.

3.21.2 Operations

1. Selecting test **4** from the DIAGNOSTIC MENU and pressing **Enter** displays the following messages:

```
DIAGNOSTICS - FLOPPY DISK HEAD CLEANING : VX.XX  
Mount cleaning disk(s) on drive(s).  
Press any key when ready.
```

2. Remove the Diagnostics Disk from the FDD, then insert the cleaning disk and press **Enter**.
3. When the "cleaning start" message appears, the FDD head cleaning has begun.
4. The display automatically returns to the DIAGNOSTIC MENU when the program is completed.

3.22 Log Utilities

3.22.1 Function Description

This function logs error information generated while a test is in progress and stores the results in RAM. This function can store data on a floppy disk, or output the data to a printer or the display.

The error information is displayed in the following order:

1. Error count (CNT)
2. Test name, Subtest number (TS-No)
3. Pass count (PASS)
4. Error status (STS)
5. FDD/HDD or memory address (ADDR)
6. Write data (WD)
7. Read data (RD)
8. HDC status (HSTS)
9. Error status name (ERROR STATUS NAME)

If the power switch is turned off, the error information will be lost.

3.22.2 Operations

1. Select **5** and press **Enter** in the DIAGNOSTIC MENU, the error information is displayed in the following format:

```

XXXXX ERRORS
CNT  TS-NO  PASS STS  ADDR  WD RD HSTS [ERROR STATUS NAME]

001  FDD 02  0000 103  00001  00 00 0000 FDD-WRITE PROTECTED
001  FDD 01  0000 180  00001  00 00 0000 FDD-TIME OUT ERROR
|      |      |      |      |      |      |      |
|      |      |      |      |      |      |      |
|      |      |      |      |      |      |      |
|      |      |      |      |      |      |      |
|      |      |      |      |      |      |      |
|      |      |      |      |      |      |      |
|      |      |      |      |      |      |      |
|      |      |      |      |      |      |      |
|      |      |      |      |      |      |      |
|      |      |      |      |      |      |      |
|      |      |      |      |      |      |      |
|      |      |      |      |      |      |      |
|      |      |      |      |      |      |      |
|      |      |      |      |      |      |      |
|      |      |      |      |      |      |      |
|      |      |      |      |      |      |      |
|      |      |      |      |      |      |      |
|      |      |      |      |      |      |      |
|      |      |      |      |      |      |      |
Error count
  
```

[[1:Next,2:Prev,3:Exit,4:Clear,5:Print,6:FD Log Read,7:FD Log Write]]

2. The error information displayed on the screen can be manipulated by the following number keys:

- The **1** key scrolls the display to the next page.
 - The **2** key scrolls the display to the previous page.
 - The **3** key returns to the Diagnostic Menu.
 - The **4** key erases all error log information in RAM.
 - The **5** key outputs the error log information to a printer.
 - The **6** key reads the log information from a floppy disk.
 - The **7** key writes the log information to a floppy disk.
3. In the case of “error retry OK”, a capital “R” will be placed at the beginning of the error status. However, it is not added to the error count.

3.23 Running Test

3.23.1 Function Description

This function automatically executes the following tests in sequence:

1. System test (subtest 01)
2. Memory test (subtests 01, 02, 06)
3. Display test (subtest 01)
4. Real timer test (subtest 02)
5. HDD test (subtest 01)

The system automatically detects the number of floppy disk drives connected to the computer for the FDD test.

3.23.2 Operations

***NOTE:** After booting up the Running test, pull out the test program and insert a floppy disk which has been formatted by **FORMAT** command of DOS.*

1. Pull out the test program and insert a floppy disk which has been formatted by **FORMAT** command of DOS.
2. Select **6** from the DIAGNOSTIC MENU and press **Enter**, the following messages for selectable tests will appear in the display in order.

```
FDD write/read test (Y/N) ?  
Printer wrap around test (Y/N) ?  
Serial wrap around test (Y/N) ?  
CD-ROM/DVD-ROM test (Y/N) ?
```

3. To execute the test, press **Y** and **Enter**. To cancel the test, press **N** and **Enter**. If you select the selectable tests, follow the instruction message in the display.
4. After selecting the selectable tests, the running test starts automatically. To terminate the program, press **Ctrl + Break**.

3.24 Floppy Disk Drive Utilities

3.24.1 Function Description

This function formats the FDD, copies the floppy disk and displays the dump list for both the FDD and HDD.

1. FORMAT

NOTE: *This program is only for testing a floppy disk drive. It is different from the Toshiba MS-DOS FORMAT command.*

This program can format a floppy disk in the following formats:

- (a) 2DD: Double-sided, double-density, double-track, 96/135 TPI, MFM mode, 512 bytes, 9 sectors/track.
- (b) 2HD: Double-sided, high-density, double-track, 96/135 TPI, MFM mode, 512 bytes, 18 sectors/track.

2. COPY

This program copies data from a source floppy disk to a target floppy disk.

3. DUMP

This program displays the contents of the floppy disk and the designated sectors of the hard disk on the display.

4. HDD ID READ

This program reads the hard disk ID and displays hard disk information.

3.24.2 Operations

1. Selecting **7** from the DIAGNOSTIC MENU and pressing **Enter** displays the following message.

```
[ FDD UTILITIES ]

1 - FORMAT
2 - COPY
3 - DUMP
4 - HDD-ID READ
9 - EXIT TO DIAGNOSTICS MENU
```

2. FORMAT program

- (a) Selecting FORMAT displays the following message.

```
DIAGNOSTICS - FLOPPY DISK FORMAT : VX.XX
Drive number select (1:A, 2:B) ?
```

- (b) Select a drive number to display the following message.

```
Type select (0:2DD, 3:2HD) ?
```

- (c) Select a media/drive type number and press **Enter**. A message similar to the one below will be displayed.

```
Warning : Disk data will be destroyed.
Insert work disk into drive A:
Press any key when ready.
```

- (d) Remove the Diagnostics Disk from the FDD, insert the work disk and press any key.

The following message will be displayed when the FDD format is executed.

```
[ FDD TYPE ] : TRACK   = XXX
[ FDD TYPE ] : HEAD    = X
[ FDD TYPE ] : SECTOR  = XX

Format start

[[track, head = XXX X]]
```

After the floppy disk is formatted, the following message will appear.

```
Format complete
Another format (1:Yes/2:No) ?
```

- (e) Typing **1** displays the message from step (c) above. Typing **2** returns the test to the DIAGNOSTIC MENU.

3. COPY program

- (a) When COPY is selected, the following message appears.

```
FLOPPY DISK FORMAT & COPY : VX.XX
Type select (0:2DD,3:2HD) ?
```

- (b) Selecting a media/drive type number will display a message similar to the one below.

```
Insert source disk into drive A:
Press any key when ready.
```

- (c) Remove the Diagnostics Disk from the FDD, insert the source disk and press any key. The following message will appear, indicating the program has started.

```
[ FDD TYPE ] : TRACK      = XXX
[ FDD TYPE ] : HEAD       = X
[ FDD TYPE ] : SECTOR     = XX

Copy start
                [[ track,head = XXX X ]]
```

- (d) The following message will appear.

```
Insert target disk into drive A:
Press any key when ready.
```

- (e) Remove the source disk from the FDD, then insert a formatted work disk and press any key. The following message will appear and start copying to the target disk.

```
                [[ track,head = XXX X ]]
```

- (f) When the amount of data is too large to be copied in one operation, the message from step (b) is displayed again. After the floppy disk has been copied, the following message will appear.

```
Copy complete
Another copy (1:Yes/2:No) ?
```

- (g) To copy another disk, type **1** and the message from step (a) is displayed again. Entering **2** returns the test program to the DIAGNOSTIC MENU.

4. DUMP program

- (a) When DUMP is selected, the following message appears.

```
DIAGNOSTICS-HARD DISK & FLOPPY DISK DUMP : VX.XX
Drive type select (1:FDD, 2:HDD) ?
```

- (b) Select a drive type. If 2:HDD is selected, the display will go to step (h). If 1:FDD is selected, the following message will appear.

```
Select drive number (1:A, 2:B) ?
```

- (c) Select a drive number and the following message will be displayed.

```
Format type select (1:2DD, 3:2HD) ?
```

- (d) If 3:2HD is selected, the following message will appear. Select a media mode.

```
2HD media mode (1:1.20MB, 2:1.44MB, 3:1.23MB)?
```

- (e) The following message will appear.

```
Insert source disk into drive A:
Press any key when ready.
```

- (f) Insert a source disk and press any key and the following message will appear.

```
— Max. address —
[Track ] = XXXX
[Head  ] = XX
[Sector] = XX
Track number ????
```

- (g) Set the track number, head number and sector number you want to dump. The system will access the disk and dump a list. Then the message shown in (k) will appear.

- (h) The following message will appear when selecting 2:HDD in (a).

```
Select drive number (1:C, 2:D) ?
```

- (i) Select a drive number and the following message will be displayed.

```
---Max. address ---
[LBA ] = XXXXXXXXXXXX
LBA number ?????????
```

- (j) Set the LBA number you want to dump. The system will access the disk and dump a list.

- (k) The following message will appear. To finish the dump, select **3**.

Press number key (1:up,2:down,3:end) ?

- (l) The following message will appear. Selecting **2** returns to the FDD UTILITIES MENU.

Another dump (1:Yes,2:No) ?

5. HDD ID READ program

Selecting HDD ID displays the following HDD ID configuration.

```
[HDD ID Read (VX.XX)] [Drive #1]
Model No.                = XXXXXXXX
```

Press **Enter** to return to the FDD UTILITIES MENU.

3.25 System Configuration

3.25.1 Function Description

NOTE: To display the system configuration, the write protect tab should be *OFF* position. If the tab is *ON* position, move the tab to *OFF* position and restart the test. Otherwise the correct information cannot be acquired.

The System Configuration program contains the following configuration information for the computer:

1. Processor Type [Code/L2 cache]
2. Chip set [VRAM]
3. BIOS ROM version [1st ID, 2nd ID]
4. Boot ROM version
5. EC total version
6. PS Microprocessor version
7. Micro code revision [Processor number]
8. Total Memory Size [Conventional memory]
9. Battery code
10. HWSC
11. FSB [Voltage]
12. The number of printer ports
13. The number of ASYNC ports
14. Math co-processors
15. Floppy Disk Drive [Track/Head/Sector]
16. Hard Disk Drive [Sector/Drive size/Manufacture code]
17. T&D total version
18. Date/Time

3.25.2 Operations

Select **8** from the DIAGNOSTIC MENU and press **Enter**. Then, the following system configuration appears in the display.

```
System Configuration Display : Ver X.XX [Machine Name ???]

* - Processor Type      = XXXXXX-XXXXXXMHz      Code = XX      L2 Cache = XXXXXXKB
* - Chip set           = XXXXXX                      VRAM = XXXXMB
* - BIOS ROM Version   = VX.XX      1st ID = XXH, 2nd ID = XXH
* - BOOT ROM Version   = VX.XX
* - EC Total Version   = VX.XX
* - PS Micon Version   = VX.XX

* - Micro code Revision = VX.XX      (Processor=XXXh)
* - Total Memory Size  = XXXXXXMB (Conventional Memory = XXXXKB)
* - Battery Code       = XXXXXXXXXXXX
* - HWSC               = XXXXXXXX
* - FSB                = XXXXXXMHz (Voltage = XEh)
* - X Printer Adapter  LPT1 = XXXX LPT2 = XXXX LPT3 = XXXX
* - X ASYNC Adapter    COM1 = XXXX COM2 = XXXX COM3 = XXXX
* - X Math CO-Processor

* - X USB Floppy Disk Drive(s) Track = XX Head = XX, Sector = XX
* - X Hard Disk Drive(s) #1 Sectors = XXXXX, (XXXXX GB) [XXXXXXXXXXXXXXXXXXXX]
                        #2 Sectors = XXXXX, (XXXXX GB) [XXXXXXXXXXXXXXXXXXXX]

* - T&D Total Version  = VX.XX

Press [Enter] Key      [Date = XXXX-YY-ZZ, XX:YY:ZZ]
```

Press **Enter** to return to the DIAGNOSTIC MENU.

3.26 Wireless LAN Test Program (Atheros)

This section describes how to perform the wireless LAN transmitting-receiving test with the test program.

NOTE: Use another computer (with Atheros 11a/g(MB44ag)/Atheros 11a/g(MB62HL)) that can communicate by the wireless LAN as a responder machine to perform this test.

The computer must be booted by the Responder T&D.

In this test, the following items are tested:

- (1) SKU check of Module
- (2) MAC Address Check
- (3) Communication test of 11a mode
- (4) Communication test of 11b mode
- (5) Communication test of 11g mode
- (6) SKU & MAC Check, 11a/b/g communication test

NOTE: This test take time until it completes.

To start the Wireless LAN test program, follow the steps below:

NOTE: Before starting the wireless LAN test, make sure the Wireless Communication Switch of the computer is turned on. (The Wireless Communication LED lights orange.)

3.26.1 Setting the responder machine

1. MB44ag is installed
 - 1) Boot the computer by MB4x Responder media.
 - 2) The Responder T&D is automatically started.
2. MB6x is installed

As the capacity of MB6x T&D is over the one of a FD, a RAM drive is used.

- 1) Boot the computer by MB6x Responder media.
- 2) After starting the OS, following message is displayed. input **m** and press **Enter**.

```

*****
*
*      Atheros MB4x/MB5x/MB6x Maintenance T&D Menu      *
*
*      s : Atheros MB4x DUT mode                          *
*
*      Please exchange FD for MB4x DUT media             *
*
*      h : Atheros MB5x DUT mode                          *
*
*      Please exchange FD for MB5x DUT media             *
*
*      r : Atheros MB5x Responder mode                    *
*
*      Please exchange FD for MB5x Responder media       *
*
*      m : Atheros MB6x setup mode                        *
*
*****

```

Please input the (s / h / r / m) key and push the "Enter" key :

- 3) The RAM drive name which has been set at booting is displayed and command input is requested. Input **mb6x X** and press **Enter**. The part of **X** is the RAM drive name. In the following display, it is "C".

```

          1,440 (1K) C:      Installed Device=RAMDRIVE
Please input the following command. "mb6x X" > mb6x c [Enter]

```

- 4) The following message is displayed. Change the FD with "MB6x setup media 1" and press **Enter**. The file copy from the FD to the RAM drive is started.

```

Please exchange FD for "MB6x setup media 1"
Press any Key to continue . . .

```

- 5) The following message is displayed. Change the FD with "MB6x setup media 2" and press **Enter**. The file copy from the FD to the RAM drive is started.

```

Please exchange FD for "MB6x setup media 2"
Press any Key to continue . . .

```

- 6) When the file copy is completed, the following test menu is displayed. Press **r**. The Responder T&D is started.

```
*****
*
*   Atheros MB6x DUT mode Maintenance T&D Menu   *
*
*   d : DUT mode                                 *
*
*   r : Responder mode                           *
*
*****

SELECT MODE No. (d or r) :
```

3.26.2 Test procedure

The following procedures show how to start the computer of DUT side.

- 1) Boot the computer by Atheros T&D boot media.
- 2) After displaying the following menu, input **m** and press **Enter**.

```
*****
*
*   Atheros MB4x/MB5x/MB6x Maintenance T&D Menu   *
*
*   s : Atheros MB4x DUT mode                       *
*
*   Please exchange FD for MB4x DUT media           *
*
*   h : Atheros MB5x DUT mode                       *
*
*   Please exchange FD for MB5x DUT media           *
*
*   r : Atheros MB5x Responder mode                 *
*
*   Please exchange FD for MB5x Responder media     *
*
*   m : Atheros MB6x setup mode                     *
*
*****
```

Please input the (s / h / r / m) key and push the "Enter" key :

- 3) The following message is displayed. Change the FD with "MB6x setup media 1" and press **Enter**. The file copy from the FD to the RAM drive is started.

```
Please exchange FD for "MB6x setup media 1"
Press any Key to continue . . .
```

- 4) The following message is displayed. Change the FD with "MB6x setup media 2" and press **Enter**. The file copy from the FD to the RAM drive is started.

```
Please exchange FD for "MB6x setup media 2"
Press any Key to continue . . .
```

- 5) When the file copy is completed, the following test menu is displayed. Press **d**. The Responder T&D is started.

```
*****
*
*   Atheros MB6x DUT mode Maintenance T&D Menu
*
*   d : DUT mode
*
*   r : Responder mode
*
*****

SELECT MODE No. (d or r) :
```

- 6) The following test menu is displayed. Select the test number.

```
*****
*   Atheros MB6x DUT mode Maintenance T&D Menu
*
*   1 : SKU check of Module
*   2 : MAC Address Check
*   3 : Communication test of 11a mode
*   4 : Communication test of 11a mode(Main Antenna Only)
*   5 : Communication test of 11b mode
*   6 : Communication test of 11b mode(Main Antenna Only)
*   7 : Communication test of 11g mode
*   8 : Communication test of 11g mode(Main Antenna Only)
*   9 : All the tests of module
*       (SKU & MAC Check,11a/b/g communication test)
*   A : All the tests of module(Main Antenna Only)
*       (SKU & MAC Check,11a/b/g communication test)
*
*****

SELECT TEST No. (1-A) :
```

3.26.3 Contents of the test and errors

1. SKU check of Module

The SKU (destination) of the Wireless LAN card installed is displayed. Visually check it.

```
*****
*
*   Module   : Atheros MB62HL (MoW)
*   G-code   : G360001Q210
*
*****
```

When an error (read error of EEPROM date) has detected, the following is displayed.

```
-----ERROR-----
file bac.txt cannot be opened
```

2. MAC Address Check

The MAC address of the installed Wireless LAN card is checked. If it is not incorrect MAC address, the following is displayed.

```
*****
*                                     *
*      MAC Address Check : OK !!      *
*                                     *
*****
```

a. Case of All FF error

```
*****
*                                     *
*      Mac Address Check NG           *
*                                     *
*      FFFFFFF-FFFFFFh               *
*                                     *
*****
```

b. Case of All 00 error

```
*****
*                                     *
*      Mac Address Check NG           *
*                                     *
*      000000-000000h                *
*                                     *
*****
```

3. Communication test of 11a mode

The check of connection of 11a mode antenna and transmitting/receiving test are executed.

When the test has been finished normally, the following is displayed.

```
*****
*                                     *
*      11a Communication Test : OK !! *
*                                     *
*****
```

When an error has detected, the following is displayed.

```
*****
*
*   11a Communication Test : NG !!   *
*
*       Please refer to log.txt      *
*
*****
```

4. Communication test of 11b mode

The check of connection of 11b mode antenna and transmitting/receiving test are executed.

When the test has been finished normally, the following is displayed.

```
*****
*
*   11b Communication Test : OK !!   *
*
*****
```

When an error has detected, the following is displayed.

```
*****
*
*   11b Communication Test : NG !!   *
*
*       Please refer to log.txt      *
*
*****
```

5. Communication test of 11g mode

The check of connection of 11g mode antenna and transmitting/receiving test are executed.

When the test has been finished normally, the following is displayed.

```
*****
*
*   11g Communication Test : OK !!   *
*
*****
```

When an error has detected, the following is displayed.

```
*****
*
*   11g Communication Test : NG !!   *
*
*       Please refer to log.txt      *
*
*****
```

6. SKU & MAC Check 11a/b/g communication test

All the test is executed in the order of SKU check of Module, MAC Address Check, Communication test of 11a mode, Communication test of 11b mode and Communication test of 11g mode.

The check of connection of 11g mode antenna and transmitting/receiving test are executed.

3.27 Wireless LAN Test Program (Intel-made a/b/g)

This section describes how to perform the wireless LAN transmitting-receiving test (Intel-made 802.11a/b/g). To execute the wireless LAN test, use the Diagnostics disk for wireless LAN test. Finish the tests of the Main test program by selecting 99 - EXIT TO DIAGNOSTICS MENU in the DIAGNOSTIC TEST MENU. Then in the DIAGNOSTICS MENU, select 9 - EXIT TO MS-DOS.

Insert the Diagnostics disk for wireless LAN test into the Floppy Disk Drive. Turn on the power while pressing **U**.

The following menu appears in the display.

```
*****
*      Intel PRO/Wireless 3945ABG Network Connection      *
*                  Maintenance T&D Menu                    *
*                                                         *
*      1  : SKU check of Module                            *
*                                                         *
*      2  : MAC Address Check                              *
*                                                         *
*      3  : Antenna Check & communication test of 11b mode *
*                                                         *
*      4  : Communication test of 11a mode                 *
*                                                         *
*      5  : Communication test of 11g mode                 *
*                                                         *
*      6  : All the tests of 11a/g Card                    *
*      (SKU & MAC Check, 11a/b/g communication test)      *
*                                                         *
*****
```

SELECT TEST No, (1-6):

To execute the subtest, input the subtest number and press **Enter**.

Subtest01 SKU check of module

This subtest displays SKU information on the wireless LAN card installed. Selecting this subtest, following message will appear in the display. Confirm if the right information on the wireless LAN card is described.

```
*****
*
*      Module   : Module : Intel PRO/Wireless 3945ABG      *
*                  Network Connection (Mowl)                *
*      G-code   : G360001U110                              *
*      TA No.   : D26539                                    *
*
*****
```

Press any key and return to the test menu.

If a defective is found during the test, **NG** message will appear in the display.

Press any key and return to the test menu.

When a defective is detected in the test, following typical cause is considered.

- Connection of wireless LAN card
- Using a wrong wireless LAN card (Using unspecified card)
- Defective wireless LAN card

Checking the connection, execute the subtest again.

Subtest02 MAC Address Check

This subtest displays the MAC address. Selecting this subtest, following message will appear in the display.

```
*****
MAC = XXXXXXXXXXXX
*****
*****
*
* MAC Address Check : OK !!
*
*****
```

Press any key and return to the test menu.

If a defective is found during the test, following message will appear in the display.

```
*****
ERROR: MAC all F
MAC = XXXXXXXXXXXX
*****
*****
*
* MAC Address Check : NG !!
*
*****
```

Press any key and return to the test menu.

When a defective is detected in the test, following typical cause is considered.

- Connection of wireless LAN card
- Defective wireless LAN card
- Disappearance of MAC address data

Checking the connection, execute the subtest again.

Subtest03 Antenna check & communication test of 11b mode

This subtest execute transmitting/receiving test in 802.11b mode using the main antenna first. If a defective is not found during the test, transmitting/receiving test in 802.11b mode using the AUX antenna is automatically executed.

If a defective is not found during the test, **OK** message will appear in the display. Press any key and return to the test menu.

If a defective is found during the test, **NG** message will appear in the display. When pressing any key, the following message (which antenna is defective) is displayed

```
*****
*
*   Main Antenna Test : NG !!
*
*****
*****
*
*   Aux Antenna Test : NG !!
*
*****
```

Press any key and return to the test menu.

Subtest04 Communication test of 11a mode

This subtest execute transmitting/receiving test in 802.11a mode using the main antenna.

If a defective is not found during the test, **OK** message will appear in the display. Press any key and return to the test menu.

If a defective is found during the test, **NG** message will appear in the display. When pressing any key, the following message is displayed

```
*****
*
*   11a Communication Test : NG !!
*
*****
```

Press any key and return to the test menu.

When a defective is detected in the test, following typical cause is considered.

- Connection of wireless LAN card
- Defective wireless LAN card
- Disappearance of MAC address data

Checking the connection, execute the subtest again.

Subtest05 Communication test of 11g mode

This subtest execute transmitting/receiving test in 802.11g mode using the main antenna.

If a defective is not found during the test, **OK** message will appear in the display. Press any key and return to the test menu.

If a defective is found during the test, **NG** message will appear in the display. When pressing any key, the following message is displayed

```
*****
*                                     *
*           11g Communication Test :  NG !!   *
*                                     *
*****
```

When a defective is detected in the test, following typical cause is considered.

- Connection of wireless LAN card
- Defective wireless LAN card
- Disappearance of MAC address data

Checking the connection, execute the subtest again.

Subtest06 All the tests of 11a/b/g Card

All the tests is executed in the order of SKU check of Module, MAC Address Check, Communication test of 11b mode, Communication test of 11a mode and Communication test of 11g mode.

When any error has detected, the test finishes.

3.28 LAN/Modem/Bluetooth/IEEE1394 Test Program

This section describes how to perform the LAN/Modem/Bluetooth/IEEE1394 test with the test program.

Insert the test program disk for LAN/Modem/Bluetooth/IEEE1394 test in FDD and turn on the power. The following message will appear:

```
Microsoft Windows XX Startup Menu
-----
```

1. LAN
2. Modem
3. Bluetooth
4. IEEE1394

Enter a choice:

Press the number you want to test and press **Enter**.

NOTE: It is impossible to go back to startup menu once you choose the test. Therefore, LAN/Modem/Bluetooth/IEEE1394 test can not be executed successively.

3.28.1 LAN test

To execute LAN test, press **1** and **Enter**. The following message will appear:

```
#####
##### i82562 ICHx GbE (i82540) Diagnostics program #####
#####
*
* 1 ..... (i82562 + ICHx) *
* * *
* 2 ..... (GbE) *
* * *
*****
.... Press test number [1-2] ?
```

Press the number you want to test and press **Enter**.

Subtest01 (i82562 + ICHx)

This subtest checks the operation of mini-PCI I/F by the loopback test in the chip.

The following message will appear:

```
[LAN transmit & receive test !]
                                COMPLETED Repeat count = 00000
                                Error count   = 00000

LOOPBACK TEST

100Mbps Auto-negotiation TxRx Test
Destination Address   = xxxxxxxxxxxxxx
Source Address       = xxxxxxxxxxxxxx

** 100Base-TX Full-Duplex **
< TRANSMIT >
< RECEIVE >
```

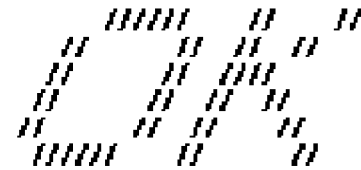

NOTE: The menu displayed by your computer may be slightly different from the one shown above.

If a defective is found, **NG** message will appear in the display.

Subtest02 (GbE)

This subtest checks the operation of mini-PCI I/F by the loopback test in the chip. Select **2** to execute and press **Enter**.

The following message will appear:

```
Testing adaptor...hit <ESC> to abort.
*
External Loopback Test...PASSED
Testing completed.
*
*
Loopback Test Complete
*
*
* 1000Base Auto-negotiation TxRx Test
*
* CE Test Complete
```

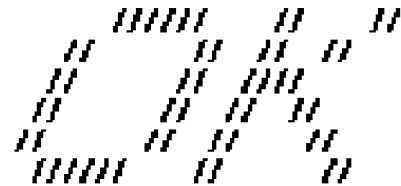

NOTE: The menu displayed by your computer may be slightly different from the one shown above.

If a defective is found, **NG** message will appear in the display.

3.28.2 Modem test

For this subtest, connect the modem PCB and RJ11 connector with a harness. Use the dedicated “FAT-MODE inspection device (product code: QE2000P01 made by Nitto Denki Seisakusyo)” for the tests.

To execute Modem test, press **2** and **Enter**. Following message will appear:

```
[Modem loopback test !]
ICHx MDC Test Program with Modem Sound (Line Test)
Version X.X
* Scorpio Modem Initialize           :OK
* Digital Loopback Test              :OK
* RJ11 Connector Check (LED)        :(Operator's Check!!)
```

NOTE: *The menu displayed by your computer may be slightly different from the one shown above.*

RJ11 Connection Check (LED) (Operator's Check LED) test will be executed, and the following message will appear:

```
...Press Key (Y = OK , N =NG)
```

If the color in the LED of the connection checker is orange, press **Y**, otherwise, press **N**.

3.28.3 Bluetooth test

To execute this test, press **3** and press **Enter**.

***NOTE:** Use another computer that can communicate by the Bluetooth as a reference machine to perform this test.*

Insert a floppy disk containing the test program into the target machine and turn on the target machine. The following Bluetooth test menu will appear:

```
#####
##### Bluetooth sub system test program VX.XX #####
#####
*
*          1...BD_ADDR check                               *
*
*          3... Communications test (DUT mode)              *
*
*          T...communications test (TEST mode)             *
*
*****
...Press test number [1, 3, T] ?
```

Press **1** or **3** key to perform the corresponding subtest. To quit the Bluetooth test program, eject the floppy disk and turn the computer off while the menu above is displayed.

Subtest01 BD_ADDR check

This subtest checks the BD_ADDR functions. When the Bluetooth test menu is displayed, press **1** to select the test and press **Enter**. The following message will appear:

```

-----
Bluetooth Subsystem T&D for PCSE(BD_ADDR) VerX.XX Copyright (C) by TOSHIBA Co.
-----

Initializing ...

```

When the machine has passed the test, it displays BD_ADDR. If BD_ADDR has no problem, the following message is displayed.

```

-----
Bluetooth Subsystem T&D for PCSE(BD_ADDR) VerX.XX Copyright (C) by TOSHIBA Co.
-----

My BD_ADDR = XXXXXXXXXXXX [h]

PPPPPP  A  SSSSS  SSSSS
P  P  A A  S  S  S  S
P  P  A  A  S  S
PPPPPP  A  A  SSSSS  SSSSS
P  AAAAAA  S  S
P  A  A  S  S  S  S
P  A  A  SSSSS  SSSSS

```

If the target machine has any problem, it displays Error CODE. The following message is displayed.

```

-----
Bluetooth Subsystem T&D for PCSE(BD_ADDR) VerX.XX Copyright (C) by TOSHIBA Co.
-----

My BD_ADDR = XXXXXXXXXXXX [h]

FFFFFF      A      III  L
F           A A      I  L
F           A  A      I  L
FFFFFF A      A      I  L
F           AAAAAA  I  L
F           A  A      I  L
F           A  A      III LLLLLL

```

Table 3-5 Error message

Message	Contents
Invalid BD_ADDR (all 00)	0x000000000000
Invalid BD_ADDR (all FF)	0xFFFFFFFFFFFF
Invalid BD_ADDR (bit0=1)	bit40=1b
Invalid BD_ADDR (bit1=1)	bit41=1b
Invalid BD_ADDR (define in the file)	Defined BD_ADDR

If the machine detects a malfunction, it indicates the error code as shown below.

The error code begins with the least significant digit.

Error code

Table 3-6 Error code for Bluetooth test (BD_ADDR) (1/2)

Error code	Meaning
0x01	Unknown HCI Command.
0x02	No Connection.
0x03	Hardware Failure.
0x04	Page Timeout.
0x05	Authentication Failure.
0x06	Key Missing.
0x07	Memory Full.
0x08	Connection Timeout.
0x09	Max Number Of Connections.
0x0a	Max Number Of SCO Connections To A Device.
0x0b	ACL Connection already exists.
0x0c	Command Disallowed.
0x0d	Host Rejected due to limited resources.
0x0e	Host Rejected due to security reasons.
0x0f	Host Rejected due to remote device is only a personal device.
0x10	Host Timeout.
0x11	Unsupported Feature or Parameter Value.
0x12	Invalid HCI Command Parameters.
0x13	Other End Terminated Connection: Used Ended Connection.
0x14	Other End Terminated Connection: Low Resources.
0x15	Other End Terminated Connection: About to Power Off.
0x16	Connection Terminated by Local Host.
0x17	Repeated Attempts.
0x18	Paring Not Allowed.
0x19	Unknown LMP PDU.
0x1a	Unsupported Remote Feature.
0x1b	SCO Offset Rejected.
0x1c	SCO Interval Rejected.
0x1d	SCO Air Mode Rejected.
0x1e	Invalid LMP Parameters.
0x1f	Unspecified Error.

See the Specification of the Bluetooth System for details.

When the Bluetooth test menu is displayed, press **T** to select the test and press **Enter** in the test machine. The following message will appear:

```

-----
Bluetooth Subsystem T&D for PCSE(CS-Air) VerX.XX Copyright (C) by TOSHIBA Co.
-----
+-----+
|           |
|   Tester   |
|           |
+-----+

[ESC]:Finish Tester  [SPACE]:Start
Is DUT ready?

```

Then press **Space** to start the Bluetooth communication test.

When the machine has passed the test, it displays BD_ADDR of the DUT. If the connection with the tester is completed, the progress bar stops. The following message is shown.

```

-----
Bluetooth Subsystem T&D for PCSE(CS-Air) VerX.XX Copyright (C) by TOSHIBA Co.
-----
+-----+
|           | BD_ADDR of the DUT = XXXXXXXXXXXXX [h]
+-----+

  CCCC   OOO   M   M PPPPPP L   EEEEEE TTTTTTT EEEEEEE DDDDD
C   C O   O MM   MM P   P L   E       T   E       D   D
C       O   O M M M M P   P L   E       T   E       D   D
C       O   O M M M PPPPPP L   EEEEEE T   EEEEEEE D   D
C       O   O M   M P   L   E       T   E       D   D
C   C O   O M   M P   L   E       T   E       D   D
  CCCC   OOO   M   M P   LLLLLL EEEEEE T   EEEEEEE DDDDD

Testing is finished

A>_

```

If the target machine has any problem, the following message “INCOMPLETE” is displayed with the Error Code.

```

-----
Bluetooth Subsystem T&D for PCSE(CS-Air) VerX.XX Copyright (C) by TOSHIBA Co.
-----

+-----+
|          DUT          |   BD_ADDR of the DUT = XXXXXXXXXXXXX [h]
+-----+

III N   N   CCCC   OOO   M   M P P P P P L   EEEEE TTTTTT EEEEE
I  NN   N C   C O   O MM   MM P   P L   E       T   E
I  N N   N C       O   O M M M M P   P L   E       T   E
I  N N   N C       O   O M M M P P P P P L   EEEEE T   EEEEE
I  N   N N C       O   O M   M P   L   E       T   E
I  N   NN C   C O   O M   M P   L   E       T   E
III N   N   CCCC   OOO   M   M P           LLLLLL EEEEE T   EEEEE

                                Testing is finished

_Press any key to continue. . .

```

If the machine detects a malfunction, it indicates the error code as shown below.

The error code begins with the least significant digit.

Error code

Table 3-7 Error code for Bluetooth test (BD_ADDR of the DUT) (1/2)

Error code	Meaning
0x01	Unknown HCI Command.
0x02	No Connection.
0x03	Hardware Failure.
0x04	Page Timeout.
0x05	Authentication Failure.
0x06	Key Missing.
0x07	Memory Full.
0x08	Connection Timeout.
0x09	Max Number Of Connections.
0x0a	Max Number Of SCO Connections To A Device.
0x0b	ACL Connection already exists.
0x0c	Command Disallowed.
0x0d	Host Rejected due to limited resources.
0x0e	Host Rejected due to security reasons.
0x0f	Host Rejected due to remote device is only a personal device.
0x10	Host Timeout.
0x11	Unsupported Feature or Parameter Value.
0x12	Invalid HCI Command Parameters.
0x13	Other End Terminated Connection: Used Ended Connection.
0x14	Other End Terminated Connection: Low Resources.
0x15	Other End Terminated Connection: About to Power Off.
0x16	Connection Terminated by Local Host.
0x17	Repeated Attempts.
0x18	Paring Not Allowed.
0x19	Unknown LMP PDU.
0x1a	Unsupported Remote Feature.
0x1b	SCO Offset Rejected.
0x1c	SCO Interval Rejected.
0x1d	SCO Air Mode Rejected.
0x1e	Invalid LMP Parameters.
0x1f	Unspecified Error.

See the Specification of the Bluetooth System in detail.

Table 3-7 Error code for Bluetooth test (BD_ADDR of the DUT) (2/2)

Error code	Meaning
0x20	Unsupported LMP Parameter Value.
0x21	Role Change Not Allowed.
0x22	LMP Response Timeout.
0x23	LMP Error Transaction Collision.
0x24	LMP PDU Not Allowed.
0x25	Not Exist
0x26	Not Exist
0x27	Not Exist
0x28	Not Exist
0x29	Not Exist
0x2a	Not Exist
0x2b	Not Exist
0x2c	Not Exist
0x2d	Not Exist
0x2e	Not Exist
0x2f	Not Exist

See the Specification of the Bluetooth System in detail.

Table 3-8 Common error code

Error code	Meaning
0x30	BT Control Status should be "Disable", but it is "Enable".
0x31	BT Control Status should be "Enable", but it is "Disable".
0x32	Power Status should be "OFF", but it is "ON".
0x33	Power Status should be "ON", but it is "OFF".
0x34	USB I/F Status should be "Attach", but it is "Detach".
0x35	USB I/F Status should be "Detach", but it is "Attach".
0x36	Wake-up Status should be non-"Assert", but it is "Assort".
0x37	Wake-up Status should be "Assert", but it is non-"Assort".
0x38	Switch Status should be "OFF", but it is "ON".
0x39	Switch Status should be "ON", but it is "OFF".
0x3a	Module dose not exist.
0x3b	Module exists. (not error)
0x3c	Command Line is wrong.
0x3d	Side band access driver is not resident.
0x3e	Bluetooth driver for DOS is not resident.
0x3f	Get Status function of Side band access driver is not normal.
0x40	No reply to inquiry
0x41	Device Descriptor can not be acquired. USB I/F is not normal.
0x42	Sideband reset timeout occurs.
0x43	Descriptor type is wrong.
0x44	Descriptor is acquired in spite of Detach condition.
0x45	Configuration file open is not normal.
0x46	Contents of Configuration file are wrong.
0x47	BD_ADDR is wrong (00)
0x48	BD_ADDR is wrong (FF)
0x49	BD_ADDR is wrong (bit0=1)
0x4a	BD_ADDR is wrong (bit1=1)
0x4b	BD_ADDR is wrong (address defined as an error)
0x4c	Suspended during Hard ware switch confirmation.
0x4d	RSSI value is less than the standard value.
0x4e	Holts
0x4f	(reserved)

Number 0x30 to 0x40 are common error codes of the test program.

3.28.4 IEEE1394 test

To execute this test, press **4** and **Enter**.

NOTE: Use another computer that can communicate by IEEE1394 (i. Link) cable as a reference machine to perform this test.

The following menu will appear:

```

*****
*****      IEEE1394[XXXXX] Diagnostics program      *****
*****
*                                                     *
*      1 ....(Transmit & Receive test)                *
*                                                     *
*      2 ....(Responder set)                          *
*                                                     *
*      3 ....(1394 GUID Display)                      *
*                                                     *
*****
.... Press test number[1-3] ?

```

To execute the TEST, select the test number you want to execute and press **Enter**.

Subtest01 Transmit & Receive test

NOTE: Before executing subtest 01, be sure to execute subtest 02 in the responder machine.

This program checks the data transporting between responder machine and target machine and compare them with the original data through the IEEE1394 cable.

Subtest 02 Responder set

This program is executed in the responder machine to initialize the responder machine with the IEEE1394 cable connected to the target machine before executing subtest 01.

Subtest 03 1394 GUID Display

This program checks the GUID of IEEE1394.

3.29 Sound Test program

This section describes how to perform the Sound test. To execute the sound test, refer to the following description.

Prepare a HDD and format it on DOS. Copy all files in the floppy disk in which the Sound test program is stored to the HDD. Reboot the computer from the HDD. The following message will appear:

```
#####
#####      WSS, Sound blaster pro Diagnostics program      #####
#####
*
*      1 .....      Sound (Standard)      *
*
*      2 .....      Sound (Legacy)      *
*
*      3 .....      CD Sound (Standard)      *
*
*      4 .....      CD Sound (Legacy)      *
*
*      ---It outputs at the speaker and lineout---      *
*
*****
.... Press test number[1-4] ?
```

Input the test number and press **Enter**.

3.29.1 Sound (Standard) test

To execute the Sound (Standard) test, press **1** and **Enter**. The following menu will appear in the display.

```
#####
#####      ICH4-M + AD1981A Diagnostics program      #####
#####
*
*      1 .....      ( Microphone recording & play )      *
*
*      2 .....      ( Sine wave )      *
*
*      3 .....      ( Line IN recording & play )      *
*
*      9 .....      Exit to Main      *
*
*****
.... Press test number[1-3, 9] ?
```

To return to the Sound test menu, press **9** and **Enter**. Then following message will appear in the display.

```
*****  
*****  May I Restart ?  *****  
*****  
Press any key to continue..
```

After pressing any key, the machine starts rebooting and sound test menu will appear in the display.

Subtest 01 Microphone recording & play

This subtest checks the function of the CODEC A/D, D/A converter.

When this subtest is selected, the following message will appear.

```
[Recording & play test !]
```

And the following message will appear.

```
DOS/4GW Protected Mode Run-time Version X.XX  
Copyright (c) Tenberry Software, Inc. XXXX
```

After this message appears, display stops briefly. In this timing, sound is recorded from internal microphone.

After the recording is completed, the computer plays back the sound recorded after the following message.

```
STACWAVE Version X.XX  
Build data: XXX XX XXXX at XX:XX:XX  
Loading "mic.wav".
```

NOTE: *The message in the display might have slight difference from those above.*

The display returns to the Sound (Standard) test menu after the test ends.

Subtest 02 Sine wave

This subtest is executed by loading the COM file (ADSIN.COM). The program expands sine wave data table from 16KB to 64KB, and creates the play data. Then it transfers the data between the DMA and the CODEC to play the sine wave. (It sounds like a continuous beep). By using wave measurable devices such as an oscilloscope, the data can be measured as a sine wave.

When the subtest is executed, the sine wave is played while expanding sine wave from 16KB to 64KB.

The display returns to the Sound (Standard) test menu after the test ends.

Subtest 03 Line IN recording & play

This subtest executes the same test as the subtest01 by recorded sound from the different port (Line-in port).

For more details on the subtest, refer to the subtest01 Microphone recording & play.

The display returns to the Sound (Standard) test menu after the test ends.

3.29.2 Sound (Legacy) test

To execute the Sound (Legacy) test, select **2** and press **Enter**.

<p>NOTE: <i>Sound (Legacy) test is not supported in this model.</i></p>

3.29.3 CD Sound (Standard) test

To execute the CD Sound (Standard) test, press **3** and **Enter**. Insert the test media (TOSHIBA TEST CD-ROM or ABEX TEST CD-ROM) or music CD on the market (if the test media can not be prepared). Following menu appears in the display.

For details on use of test media, refer to 3.28.3.1 Test media (Toshiba-made test media).
For details on use of audio CD on the market, refer to 3.28.3.2 Audio CD.

3.29.3.1 Test media (Toshiba-made test media)

CD/DVD TEST IN PROGRESS XXXXXXXX

```
xxxxxxx DIAGNOSTIC TEST VX.XX
[Ctrl]+[Break] : test end
[Ctrl]+[C]      : key stop
```

```
SUB-TEST      : XX
PASS COUNT    : XXXXX      ERROR COUNT: XXXXX
WRITE DATA   : XX         READ DATA  : XX
ADDRESS       : XXXXXXX    STATUS      : XXX
```

```
01 - Japanese Narration
02 - English Narration
03 - Test Tone A (100Hz - 20Hz)
04 - Test Tone B (400Hz - 3KHz L-R)
```

```
Drive # = 0, ATAPI status =00
Command = XX
[[Block address = XXXXXXXXX]]
[[Block length  = XXXXXXXXX]]
Final : Block address = XXXXXXXXX
```

Subtest 01 Japanese Narration

Selected this subtest, narration in Japanese starts and following message appears in the display.

```
Play start CD sound !
Press any key <Play stop>.
```

Press any key and stop the narration. Then return to the CD Sound (Standard) test menu.

Subtest 02 English Narration

Selected this subtest, narration in English starts.

For more details on the procedure, refer to the subtest01.

Subtest 03 Test Tone A

CAUTION: Before starting subtest03, be sure to set the sound at proper volume.

This subtest plays sine wave while changing its table from 100Hz to 20Hz.

The test returns to the CD Sound (Standard) menu after the test ends.

Subtest 04 Test Tone B

This subtest plays sine wave while changing its table from 400Hz to 3KHz and also changing the channel from left speaker to right speaker.

The test returns to the CD Sound (Standard) menu after the test ends.

CAUTION: This model does not support the CD Sound (Standard) test.

3.29.3.2 Audio CD

Insert an audio CD and the following menu appears in the display.

```

CD/DVD TEST  IN PROGRESS XXXXXXXX
xxxxxxx DIAGNOSTIC TEST VX.XX
[Ctrl]+[Break] ; test end
[Ctrl]+[C]      ; key stop

SUB-TEST      : XX
PASS COUNT   : XXXXX      ERROR COUNT: XXXXX
WRITE DATA  : XX         READ DATA   : XX
ADDRESS      : XXXXXXXX   STATUS       : XXX

```

```

CD Sound track number (01-98 : Track) ?

Drive # = 0, ATAPI status =00
Command = XX
[[Block address = XXXXXXXXX]]
[[Block length  = XXXXXXXXX]]

Final : Block address = XXXXXXXXX

```

Select the track number you want to test and press **Enter** twice.

The following message appears in the display and selected track is played.

```

Play start CD sound !
Press any key <play stop>

```

After pressing any key, the music stops and the display returns to the selection menu of the track number.

NOTE: When the CD-ROM test is executed, [ALL DEVICE] must be selected in the "Device Config.=" of the BIOS SETUP. If the "ALL DEVICE" is not selected, music can not be played.

3.29.4 CD Sound (Legacy) test

To execute the CD Sound (Legacy) test, select **4** and press **Enter**.

CAUTION: Sound (Legacy) test is not supported in this model.

3.30 SETUP

3.30.1 Function Description

This program displays the current system setup information as listed below:

1. Memory
 - (a) Total
2. System Date/Time
 - (a) Date (MM-DD-YYYY)
 - (b) Time (HH:MM:SS)
3. Battery
 - (a) Battery Save Mode
 - (b) PCI Express Link ASPM
 - (c) Enhanced C-States
4. Password
5. HDD Password
 - (a) HDD
 - (b) HDD Password Mode
 - (c) User Password
 - (d) Master Password
6. Boot Priority
 - (a) Boot Priority
 - (b) HDD Priority
 - (c) Network Boot Protocol
7. Others
 - (a) Core Multi-Processing
 - (b) Dynamic CPU Frequency Mode
 - (c) Execute-Disable Bit Capability
 - (d) Virtualization Technology
 - (e) Auto Power On
 - (f) Beep Volume
 - (g) Diagnostic Mode
 - (h) Language During Bootup

8. Configuration
 - (a) Device Config.
9. Drives I/O
 - (a) Built-in HDD
 - (b) CD-ROM
10. PCI Bus
 - (a) PCI Bus
11. Security Controller
 - (a) TPM
 - (b) Clear TPM Owner
12. Display
 - (a) Power On Display
 - (b) LCD Display Stretch
13. Peripheral
 - (a) Internal Pointing Device
14. Legacy Emulation
 - (a) USB KB/Mouse Legacy Emulation
 - (b) USB-FDD Legacy Emulation
 - (c) USB Memory BIOS Support Type
15. PCI LAN
 - (a) Built-in LAN

3.30.2 Accessing the SETUP Program

Turn on the power while pressing **ESC**, the following menu appears.

Check system. Then press [F1] key.

Then press **F1**. The following display appears.

SYSTEM SETUP (1/2) ACPI BIOS version = X.XX

<p style="text-align: center;">MEMORY</p> <p>Total = XXXXX MB</p>	<p style="text-align: center;">BOOT PRIORITY</p> <p>Boot Priorit = HDD → FDD → CD-ROM → LAN HDD Priority = Built in HDD → USB Network Boot Protocol = PXE *3</p>
<p style="text-align: center;">SYSTEM DATE/TIME</p> <p>Date (MM-DD-YY) = XX-XX-XXXX Time (HH:MM:SS) = XX:XX:XX</p>	<p style="text-align: center;">OTHERS</p> <p>Core Multi-Processing = Enabled *1 Dynamic CPU Frequency Mode *1 = Dynamically Switchable Execute-Disable Bit Capability = Not Available Virtualization Technology = Disabled *5 Auto Power On = Disabled Beep Volume = Medium Diagnostic Mode = Disabled</p>
<p style="text-align: center;">BATTERY</p> <p>Battery Save Mode = Full Power PCI Express Link ASPM = Enabled Enhanced C-States = Enabled *1</p>	
<p style="text-align: center;">PASSWORD</p> <p>Not Registered</p>	
<p style="text-align: center;">HDD PASSWORD*2</p> <p>HDD = Built-in HDD HDD Password Mode = Master+User User Password = Not Registered Mastere Password = Not registered</p>	

||←→: Select items **Space, BkSp**: Change values **PgDn, PgUp**: Change pages
Esc: Exit without saving **Home**: Set default values **End**: Save changes and Exit

SYSTEM SETUP (2/2) ACPI BIOS version = X.XX

<p style="text-align: center;">CONFIGURATION</p> <p>Device Config. = Setup by OS</p>	<p style="text-align: center;">DISPLAY</p> <p>Power On Display = Auto-Selected LCD Display Stretch = Enabled</p>
<p style="text-align: center;">DRIVERS I/O</p> <p>Built-in HDD = Primary IDE (1F0H/IRQ14) CD-ROM = Secondary IDE (170H/IRQ15)</p>	<p style="text-align: center;">PERIPHERAL</p> <p>Internal Pointing Device = Enabled</p>
<p style="text-align: center;">PCI BUS</p> <p>PCI BUS = IRQ10, IRQ11</p>	<p style="text-align: center;">LEGACY EMULATION</p> <p>USB KB/Mouse Legacy Emulation = Enabled USB-FDD Legacy Emulation = Enabled USB Memory BIOS Support Type = HDD</p>
<p style="text-align: center;">SECURITY CONTROLLER*4</p> <p>TPM = Disable Clear TPM Owner</p>	<p style="text-align: center;">PCI LAN</p> <p>Built-in LAN = Enabled</p>

||←→: Select items **Space, BkSp**: Change values **PgDn, PgUp**: Change pages
Esc: Exit without saving **Home**: Set default values **End**: Save changes and Exit

NOTE: *1: This appears in Intel® Core™ models.
*2: This appears in PORTÉGÉ M500 (only PPM51) and TECRA M6.
*3: This appears in models that have 10/100M Ether Net LAN.
*4: This appears in models that have a CPU supporting TPM.
*5: This appears in models that have a CPU supporting this function.

Moving Within the SETUP Menu and Changing Values

1. Press ← and → to move between the two columns. Press ↑ and ↓ to move between items in a column. Press **Fn+↑ (PgUp)** and **Fn + ↓ (PgDn)** to move between the two pages.
2. Press either the **Space bar** or **Back Space** to change the value.

Accepting Changes and Exiting the SETUP Window

1. Press **End** to accept the changes you made.

If the changed item does not require the system to reboot, the following message is displayed:

Are you sure? (Y/N)

If the changed item requires the system to reboot, the following message is displayed:

Are you sure? (Y/N)

The changes you made will cause the system to reboot.

2. To make other changes, press **N**. Repeat the steps above.
3. To accept the changes, press **Y**.

NOTE: You can press **Esc** to quit at any time without saving changes. *SETUP* asks you to confirm that you do not want to save your changes. When *SETUP* is displayed at the next time, the current configuration appears.

The Factory Preset Configuration

When you access *SETUP*, the current configuration is displayed.

1. To show the factory preset configuration, press **Home**.
2. Press **End** and then press **Y** to accept the factory preset settings.

NOTE: When you execute the default setting, the following settings are not changed:
Password
Execute-Disable Bit function

SETUP Options

The SETUP screen is divided into functionally related groups. This section describes each group and its options.

1. Memory

This group of options displays the computer's memory.

(a) Total

This field displays the total amount of memory installed and is automatically calculated by the computer. You cannot change this value.

2. System Date/Time

Use this option to set the computer's system date/time. Press ↓ to move the cursor to the right and press ↑ to move the cursor to the left. Press the **space bar** to increase the number and press **BkSp** to decrease the number.

(a) Date

Use this option to set the system date of the computer.

(b) Time

Use this option to set the system time of the computer.

3. Battery

This option is used to select Full Power, Low Power or User Setting of the battery save mode.

Full Power The following shows full power settings.

```

  BATTERY SAVE OPTIONS
Processing Speed  = High
CPU Sleep Mode   = Enabled
LCD Brightness   = Bright (*2)
                  Super-Bright (*3)
Cooling Method   = Maximum Performance
```

Low Power The following shows low power settings.

```

BATTERY SAVE OPTIONS
Processing Speed = Low
CPU Sleep Mode = Enabled
LCD Brightness = Super-Bright (*3)

Cooling Method
                = Maximum Performance
  
```

(a) **Battery Save Mode**

When “User Setting” is selected, the sub-window, BATTERY SAVE OPTION is displayed. The following set of options can be selected in the submenu.

Processing Speed

This feature changes the CPU processing speed.

High CPU operates at high speed. (Default)

Low CPU operates at low speed.

CPU Sleep Mode

Use this option to enable or disable the CPU sleep function.

Enabled Enables sleep mode. (Default)

Disabled Disables sleep mode.

LCD Brightness

Use this option to set the level of LCD brightness.

Super-Bright Full brightness for maximum visibility.

Bright Full brightness for high visibility. (Default)

Semi-Bright Less than full brightness for saving power.

Cooling Method

If the CPU becomes too hot, the fan turns on or the processing speed is lowered automatically. When the CPU temperature falls to a normal range, the fan turns off.

Maximum performance Turns on the fan first, and if necessary, lowers CPU processing speed. (Default)

Battery optimized Lowers the CPU processing speed first, and if necessary, turns on the fan.

(b) PCI Express Link ASPM

- Enabled** Saves power consumption, when the PCI Express device is not used. (Default)
- Auto** Saves power consumption, when the PCI Express device is not used while the battery is working.
- Disabled** Disables the power saving function and gives priority to the performance.

(c) Enhanced C-States

This feature enables or disables the Enhanced C-States.

- Enabled** This lowers the power consumption.
- Disabled** This does not lower the power consumption.

4. Password

This option allows you to set or reset the user password for power on.

- Not Registered** Change or remove the password. (Default)

For details on setting the user password, refer to the User's Manual.

5. HDD Password

This option sets HDD password. HDD password is a security function to protect the built-in HDD.

(a) HDD

This item selects the hard disk to set HDD password.

- Built-in HDD** Sets HDD password for the built-in HDD

(b) HDD Password Mode

This item registers HDD password and can be selected only for registering HDD password. To change HDD Password Mode when HDD password is registered, delete the registered HDD password first, and then register new password.

- User Only** Sets only User HDD Password (Default)
- Master+User** Sets Master HDD Password and User HDD Password

(c) User Password

This item sets User password.

For details on setting user password, refer to the User's Manual.

(d) Master Password

This item sets the Master HDD password.

This can be set **Master+User** is set in the HDD password Mode. For details, refer to the User's Manual.

6. Boot Priority

This tab sets the priority for booting the computer and the priority for the built-in HDD or optional secondary HDD.

(a) Boot Priority

- HDD→FDD→CD-ROM→LAN:** The computer looks for bootable files in the following order: HDD, FDD, CD-ROM and LAN. (Default)
- FDD→HDD→CD-ROM→LAN:** The computer looks for bootable files in the following order: FDD, HDD, CD-ROM and LAN.
- HDD→CD-ROM→LAN→FDD:** The computer looks for bootable files in the following order: HDD, CD-ROM, LAN and FDD.
- FDD→CD-ROM→LAN→HDD:** The computer looks for bootable files in the following order: FDD, CD-ROM, LAN and HDD.
- CD-ROM→LAN→HDD→FDD:** The computer looks for bootable files in the following order: CD-ROM, LAN, HDD and FDD.
- CD-ROM→LAN→FDD→HDD:** The computer looks for bootable files in the following order: CD-ROM, LAN, FDD and HDD.

NOTE: CD-ROM refers to a DVD-ROM&CD-R/RW drive or DVD Super Multi drive.

(b) HDD Priority

This option enables to select the priority for the Built-in HDD or USB.

Built-in HDD → **USB** (Default)

USB → **Built-in HDD**

(c) Network Boot Protocol

Use this option to set the starting method via a network.

PXE Sets to PXE protocol. (Default)

RPL Sets to RPL protocol.

7. Others

Whether or not you need to configure the computer with these options depends primarily on the kind of software or peripherals you use.

(a) Core-Multi Processing

The Core Multi-Processing sets the CPU operating mode of Core Multi-Processor.

Enabled Enables Core Multi-Processing functions. (Default)

Disabled Disables Core Multi-Processing functions.

(b) Dynamic CPU Frequency Mode

Use this option to choose a setting from the followings.

Dynamically Switchable

Enables Intel SpeedStep technology. When the computer is in use, the CPU power consumption and clock speed are automatically switched when necessary. (Default)

Always High Disables Intel SpeedStep technology and always runs the processor at its fastest speed.

Always Low Disables Intel SpeedStep technology and always runs the processor at low power consumption and low speed.

(c) Execute-Disable Bit Capability

Selects the function to reports whether the CPU Execute-Disable Bit is available or not to OS. When the CMOS is damaged, the default is **Available**. When **Home** is pressed, the setting is not changed and the setting is kept.

Available Reports that the function is available.

Not Available Reports that the function is not available. (Default)

(d) Virtualization Technology

Virtualization Technology sets enable or disable of the Intel Virtualization Technology installed in the CPU.

Intel Virtualization Technology is the technique that allows one machine to operate as multiple virtual machines.

Enabled Enables Virtualization Technology.

Disabled Disables Virtualization Technology. (Default)

(e) Auto Power On

Use this option to set a time and date for automatic power on and enable or disable the ring indicator feature. **Alarm Date Option** appears only when **Alarm Time** is enabled.

OPTIONS	
Alarm Time	= 00:00:00
Alarm Date Option	= Disabled
Wake-up on LAN	= Disabled*

*Only for LAN Model

Alarm Time is set in the sequence of hours and minutes. Seconds cannot be changed. **Alarm Date Option** is set in the sequence of month and day. If Alarm Date is set to Disabled, the computer will be powered on at the same time every day. Press ↓ to move the cursor to the right and ↑ to move the cursor to the left when you set the date and time.

NOTE: 1. Do not remove the AC adapter and battery pack at the same time when you use this feature. If you do so, data saved by the resume function will be lost. You must also reset this option.

2. When a password is set in Password Security, the system is in standby mode, the Timer on function (Auto Power PN) is set and the system is booted, "Password =" is displayed. When the password set in Password Security is input, the computer returns to Windows from standby mode.

3. This function is effective only once, it is released after booting up.

(f) Beep Volume

This option selects the volume of beep (Warning). “OFF”, “Low”, “Medium” (Default) or “High” can be selected. If a memory module that does not comply with the standards, the computer beeps at maximum volume.

(g) Diagnostic Mode

This option sets whether the BIOS Setup Diagnostic test is enabled.

Disabled The Diagnostic test is disabled. (Default)

Enabled The Diagnostic test is enabled.

(h) Language During Bootup

This option selects the language during bootup. This message appears only on the model for TCL (Canada).

English The message is displayed in English. (Default)

French The message is displayed in French.

8. Configuration

This option displays the configuration method.

(a) Device Config.

The devices are initialized when the PNP OS loads.

Setup by OS First, devices necessary for loading the OS will be initialized. After the PNP OS loads, the OS will initialize other devices. In this case, setup of PC Cards will be fixed to “Auto-Selected” and cannot be changed. (Default)

All Devices All devices will be initialized.

If you are using an OS that does not have PNP capacity, select “All Devices.” The Display shows the following message:

Device Config. = All Devices

9. Drives I/O

This option displays the address/interrupt level for hard disk drive and optical drive. It is only for information and cannot be changed.

(a) Built-in HDD

This option displays the setting of the address and interrupt level of the HDD. This cannot be changed.

(b) CD-ROM

This option displays the setting of the address and interrupt level of the installed drive. This cannot be changed. Even if an installed drive is not CD-ROM drive, "CD-ROM" is displayed.

10. PCI Bus

This item displays the interrupt level for the Card Bus. It is for information only and cannot be changed.

PCI BUS = IRQ10, IRQ11

11. Security controller

(a) TPM

Disables the security controller called TPM (Trusted Platform Module). When the cursor is on the **Enable (Disable)** and the **Space** is pressed, message is displayed and the PC waits **Y** or **N** key input by the user. When **Y** is pressed, it is sets to **Enable (Disable)**. After changing, the cursor could not be moved on the **TPM** tem. This option can be changed after rebooting.

Disabled Disables the TPM. (Default)

Enabled Enables the TPM.

(b) Clear TPM Owner

This is not displayed when the **TPM** is set to **Disabled**. This is executed, when the PC is disposed or the owner of the PC changes. When the cursor is on this item and the **Space** is pressed, message is displayed and the PC waits **Y, E, S** and **Enter** key inputs by the user. When **Y, E, S** and **Enter** keys are pressed, the data is disposed. After changing, the display of **TPM** item is changed to **Disabled** and this item becomes not displayed and the cursor could not be moved on the **TPM** item.

12. Display

This group of options configures the computer's display.

(a) Power On Display

This option is used to select the display when booting up.

Auto-Selected Selects an external monitor if one is connected.
Otherwise it selects the internal LCD. (Default)

LCD+AnalogRGB Selects both the internal LCD and the external monitor
for simultaneous display.

NOTE: Pressing **Fn+F5** changes the display setting in the order of internal LCD to simultaneous to external monitor.

(b) LCD Display Stretch

LCD Display Stretch enables or disables a larger display area of the screen.

Enabled Enables the LCD display stretch feature. (Default)

Disabled Disables the LCD display stretch feature.

13. Peripheral

Use this option to select the parallel port mode and hard disk mode.

(a) Internal Pointing Device

This option enables and disables the Touch Pad.

Enabled Enables the Touch Pad. (Default)

Disabled Disables the Touch Pad.

14. Legacy Emulation.

(a) USB KB/Mouse Legacy Emulation.

Use this option to enable or disable USB KB/Mouse Legacy Emulation. If your operating system does not support USB, you can still use a USB mouse and keyboard by setting the **USB KB/Mouse Legacy Emulation** item to **Enabled**.

Enabled USB Legacy Support can be used. (Default)

Disabled USB Legacy Support cannot be used.

(b) USB-FDD Legacy Emulation.

Use this option to enable or disable USB-FDD Legacy Emulation.

Enabled USB Legacy Support can be used. (Default)

Disabled USB Legacy Support cannot be used.

(c) USB Memory BIOS Support Type

Sets the type of the USB memory as a startup device.

HDD Set the type of the USB memory to be equivalent to the HDD (Default).

Based on the [HDD] order in the [Boot Priority Options] item. The order with respect to the other HDD can be set in the [HDD Priority Options] item.

FDD Set the type of the USB memory to be equivalent to the FDD.

Based on the [FDD] order in the [Boot Priority Options] item.

15. PCI LAN

This option enables/disables the Built-in LAN functions.

(a) Built-in LAN

Enabled Enables Built-in LAN functions. (Default)

Disabled Disables Built-in LAN functions.

Chapter 4

Replacement Procedures

[CONFIDENTIAL]

Chapter 4 Contents

4.1	General.....	4-1
4.2	Battery pack	4-8
4.3	PC card.....	4-10
4.4	Bridge media.....	4-11
4.5	HDD.....	4-12
4.6	Optical drive	4-15
4.7	Keyboard.....	4-18
4.8	Memory module.....	4-21
4.9	Cover FAT assembly	4-23
4.10	Fingerprint sensor board	4-28
4.11	Touch pad.....	4-30
4.12	SW membrane.....	4-32
4.13	Bluetooth module.....	4-34
4.14	Wireless LAN card	4-36
4.15	MDC (Modem Daughter Card).....	4-38
4.16	Internal microphone.....	4-40
4.17	RTC battery	4-42
4.18	Harness holder/LAN cable.....	4-44
4.19	System board/DC-IN jack.....	4-47
4.20	Modem jack/Wireless communication SW	4-50
4.21	Fan/CPU.....	4-53
4.22	HDD cable/PC card slot.....	4-57
4.23	LCD unit/FL inverter	4-59
4.24	Speaker/LCD cable	4-65
4.25	Cover latch.....	4-67
4.26	Wireless LAN antenna/Bluetooth antenna	4-68
4.27	Hinge.....	4-70
4.28	Battery slider.....	4-72
4.29	Fluorescent Lamp.....	4-73
	4.29.1 Replacing the 12.1-inch WXGA TMD Fluorescent Lamp	4-74
	4.29.2 Replacing the 12.1-inch WXGA Samsung Fluorescent Lamp.....	4-85

Figures

Figure 4-1	Removing the battery pack	4-8
Figure 4-2	Removing the PC card	4-10
Figure 4-3	Removing the Bridge media (SD card)	4-11
Figure 4-4	Removing the HDD cover	4-12
Figure 4-5	Separating the HDD and HDD holder	4-13
Figure 4-6	Removing the optical drive.....	4-15
Figure 4-7	Disassembling the optical drive.....	4-16
Figure 4-8	Removing the keyboard holder.....	4-18
Figure 4-9	Removing the keyboard support plate	4-19
Figure 4-10	Removing the memory module.....	4-21
Figure 4-11	Removing the Cover FAT assembly (1).....	4-23
Figure 4-12	Removing the Cover FAT assembly (2).....	4-24
Figure 4-13	Removing the Cover FAT assembly (3).....	4-25
Figure 4-14	Removing the Cover FAT assembly (4).....	4-26
Figure 4-15	Removing the fingerprint sensor board	4-28
Figure 4-16	Removing the touch pad assembly	4-30
Figure 4-17	Removing the SW membrane (1)	4-32
Figure 4-18	Removing the SW membrane (2)	4-33
Figure 4-19	Removing the Bluetooth module	4-34
Figure 4-20	Removing the wireless LAN card.....	4-36
Figure 4-21	Removing the MDC (Modem Daughter Card).....	4-38
Figure 4-22	Removing the internal microphone.....	4-40
Figure 4-23	Removing the RTC battery	4-43
Figure 4-24	Removing the Harness holder/LAN cable (1)	4-44
Figure 4-25	Removing the Harness holder/LAN cable (2)	4-45
Figure 4-26	Removing the System board / DC-IN jack (1).....	4-47
Figure 4-27	Removing the System board / DC-IN jack (2).....	4-48
Figure 4-28	Removing the System board / DC-IN jack (3).....	4-48
Figure 4-29	Removing the Modem jack.....	4-50
Figure 4-30	Removing the wireless communication SW	4-51

Figure 4-31	Removing the CPU holder	4-53
Figure 4-32	Removing the fan	4-54
Figure 4-33	Removing the CPU	4-54
Figure 4-34	Installing the CPU.....	4-55
Figure 4-35	Applying new grease	4-56
Figure 4-36	Removing the HDD cable.....	4-57
Figure 4-37	Removing the PC card slot	4-58
Figure 4-38	Removing the display assembly.....	4-59
Figure 4-39	Removing the LCD mask.....	4-60
Figure 4-40	Removing the FL inverter.....	4-61
Figure 4-41	Removing the LCD unit.....	4-62
Figure 4-42	Removing the LCD support	4-63
Figure 4-43	Removing the speaker.....	4-65
Figure 4-44	Removing the LCD cable.....	4-66
Figure 4-45	Removing the cover latch	4-67
Figure 4-46	Removing the wireless LAN antenna/Bluetooth antenna.....	4-68
Figure 4-47	Removing the hinge	4-70
Figure 4-48	Removing the battery slider	4-72
Figure 4-49 to 4-58	Replacing TMD fluorescent lamp (1) to (10).....	4-75 to 4-84
Figure 4-59 to 4-62	Replacing Samsung fluorescent lamp (1) to (4)	4-85 to 4-87

4.1 General

This section explains how to disassemble the computer and replace Field Replaceable Units (FRUs). It may not be necessary to remove all the FRUs in order to replace one. The chart below is a guide to which FRUs need to be removed in order to remove others. Always start by removing the battery pack, next, optional items such as the optional PC card and optional SD card, then follow the line on the chart to determine which FRU you must remove next in order to repair the one you think is causing the computer to operate improperly. Refer to the example at the bottom of the page.

4.2 Battery pack	
4.3 PC card 4.4 Bridge media	
4.7 Keyboard	4.5 HDD 4.6 ODD
4.9 Cover FAT assembly	4.8 Memory module
4.10 Finger print sensor board 4.11 Touch pad 4.12 SW membrane 4.13 Bluetooth module 4.14 Wireless LAN card 4.15 MDC 4.16 Internal microphone 4.17 RTC battery	
4.18 Harness holder/LAN cable	
4.19 System board/DC-IN jack	
4.20 Modem jack/Wireless communication SW 4.21 Fan/CPU 4.22 HDD cable/PC card slot 4.28 Battery slider	4.23 LCD unit/FL inverter 4.24 Speaker/LCD cable 4.29 Fluorescent lamp 4.25 Cover latch
4.26 Wireless LAN antenna/ Bluetooth antenna	
4.27 Hinge	

How to see the chart:

This chart shows which unit(s) you need to remove in advance when you replace one unit.

Example:

When you want to replace touch pad, you need to remove units, in the hatched boxes above the boxes in which the touch pad is.

4.2 Battery pack	
4.3 PC card 4.4 Bridge media	
4.7 Keyboard	4.5 HDD 4.6 ODD
4.9 Cover FAT assembly	4.8 Memory module
4.10 Finger print sensor board 4.11 Touch pad 4.12 SW membrane 4.13 Bluetooth module 4.14 Wireless LAN card 4.15 MDC 4.16 Internal microphone 4.17 RTC battery	
4.18 Harness holder/LAN cable	
4.19 System board/DC-IN jack	
4.20 Modem jack/Wireless communication SW 4.21 Fan/CPU 4.22 HDD cable/PC card slot 4.28 Battery slider	4.23 LCD unit/FL inverter 4.24 Speaker/LCD cable 4.29 Fluorescent lamp 4.25 Cover latch
4.26 Wireless LAN antenna/ Bluetooth antenna	
4.27 Hinge	

Safety Precautions

Before you begin disassembly, read the following safety precautions and observe them carefully as you work.

- DANGER:**
- 1) *Always use the genuine battery that is authorized by Toshiba or compatible with the unit. Since other battery packs have different specifications, they may be incompatible with the unit, and may burst or explode.
Never heat or disassemble the battery pack, as that could cause leakage of alkaline solution. Never throw the battery pack into a fire, as that could cause the battery pack to explode.*
 - 2) *The power supply, FL inverter and other components carry high voltages. If you need to turn on the power of a partially disassembled computer to check its operation, be very careful not to touch connectors or components, in order to avoid the risk of electric shock. Also, do not disassemble individual components in first-level maintenance.*

- WARNING:**
- 1) *Turn off the power and disconnect the AC adaptor from the power source, to avoid exposure to electric shock.*
 - 2) *Batteries in the computer retain an electrical charge, so there is danger of electrical shock even when the computer is disconnected from an AC power source. Remove any metal jewelry or accessories such as necklaces, bracelets or rings, in order to reduce the risk of electric shock. Never work with wet or damp hands.*
 - 3) *Be careful of edges and corners as these may cut.*

- CAUTION:**
- 1) *When you change a component, be sure the replacement component meets the required specifications. Never use foreign parts, to avoid any risk of damage to the computer.*
 - 2) *To avoid any risk of short-circuit, fire or other internal damage, never allow any metal objects such as screws or paper clips to fall into the unit. Be sure to replace screws with the same size as those removed. Make sure all screws are securely fastened. Loose screws can cause short circuits, resulting in heat, smoke or fire.*
 - 3) *Before lifting out an FRU or other component, make sure all cables to the component have been disconnected, in order to reduce the risk of accidental electric shock.*
 - 4) *If you use AC power, be sure to use the cable that came with the computer or one recommended by Toshiba.*
 - 5) *Make sure that all replacement components meet the specifications for the computer and that all cables and connectors are securely fastened, in order to avoid the risk of electric shock.*
 - 6) *Some parts inside the computer, such as the CPU and cooling module, become very hot during operation. Conduct repair work after they have cooled. Be careful around the CPU and cooling module to avoid burns.*

Before You Begin

Look over the procedures in this section before you begin disassembling the computer. Familiarize yourself with the disassembly and reassembly steps. Begin each procedure by removing the AC adapter and the battery pack as instructed in this section:

1. Do not disassemble the computer unless it is operating abnormally.
2. Use only the correct and approved tools.
3. Make sure the working environment is free from the following elements whether you are using or storing the computer.
 - Dust and contaminants
 - Static electricity
 - Extreme heat, cold and humidity
4. Make sure the FRU you are replacing is causing the abnormal operation by performing the necessary diagnostics tests described in this manual.
5. Do not perform any operations that are not necessary and use only the described procedures for disassembling and installing FRUs in the computer.
6. After removing parts from the computer, place them in a safe place away from the computer so they will not be damaged and will not interfere with your work.
7. You will remove and replace many screws when you disassemble the computer. When you remove screws, make sure they are placed in a safe place and identified with the correct parts.
8. When assembling the computer make sure you use the correct screws to secure the various pieces in place. Screw sizes are listed in their corresponding figures.
9. The computer contains many sharp edges and corners, so be careful not to injure yourself.
10. After you have replaced an FRU, make sure the computer is functioning properly by performing the appropriate test on the FRU you have fixed or replaced.

Disassembly Procedures

The computer has two basic types of cable connectors:

- Pressure Plate Connectors
- Coaxial Cable Connectors
- Normal Pin Connectors

To disconnect a Pressure Plate connector, lift up the tabs on either side of the connector's plastic pressure plate and slide the cable out of the connector. To connect the cable to a Pressure Plate connector, make sure the pressure plate is fully lifted and slide the cable into the connector. Secure the cable in place by pushing the sides of the pressure plate down so the plate is flush with the sides of the connector. Gently pull on the cable to make sure the cable is secure. If you pull out the connector, connect it again making sure the connector's pressure plate is fully lifted when you insert the cable.

Coaxial cables should be disconnected with an antenna coaxial disconnecter.

Normal Pin connectors are used with all other cables. These connectors can be connected and disconnected by simply pulling them apart or pushing them together.

Assembly Procedures

After you have disassembled the computer and fixed or repaired the problem that was causing the computer to operate abnormally, you will need to reassemble the computer.

Install all the removed FRUs following the steps described in the corresponding sections in this chapter.

While assembling the computer, remember the following general points:

- Take your time, making sure you follow the instructions closely. Most problems arise when you get in a hurry assembling the computer.
- Make sure all cables and connectors are securely fastened.
- Before securing the FRU or other parts, make sure that screws or the FRU will pinch no cables.
- Check that all latches are closed securely in place.
- Make sure all the correct screws are used to secure all FRUs. Using the wrong screw can either damage the threads on the screw or the head of the screw and may prevent proper seating of an FRU.

After installing an FRU in the computer, confirm that the FRU and the computer are functioning properly.

Tools and Equipment

The use of Electrostatic Discharge (ESD) equipment is very important for your safety and the safety of those around you. Proper use of these devices will increase the success rate of your repairs and lower the cost for damaged or destroyed parts. The following equipment is necessary to disassemble and reassemble the computer:

- One M2 point size 0 Phillips screwdriver
- One M2.5/M3 point size 1 Phillips screwdriver
- One screw driver for stud screw
- One 4 mm flat-blade screwdriver
- Tweezers, to lift out screws that you cannot grasp with your fingers
- ESD mats for the floor and the table you are working on
- An ESD wrist strap or heel grounder
- Anti-static carpeting or flooring
- Air ionizers in highly static sensitive areas
- Plastic card of the size of credit card
- Antenna coaxial cable disconnecter

Screw Tightening Torque

When you fasten screws, be sure to follow the torque list below.

CAUTION: *Overtightening can damage components and screws; undertightening can result in electrical shorts or other damage if screws or components come loose.*

NOTE: *Toshiba recommends that you use an electric screw driver for quick and easy operations.*

- M2 0.167 N·m (1.7 kgf·cm)
- M2.5 0.294 N·m (3.0 kgf·cm)
- M3 0.549 N·m (5.6 kgf·cm)

NOTE: *The computer contains several flat head screws. These screws have less contact area with the screwdriver, so be careful to press firmly enough to prevent the screwdriver from slipping out and damaging the screw head.*

Color of Screw Shaft

To avoid mistakes on the screw length, screw shafts are colored as follows:

- Even number length screw: brown
- Odd number length screw: white
- Special length screw: blue

Screws whose lengths are indicated to one or more decimal places such as 2.5 mm or 2.8 mm.

Marking of Screws on the Computer Body

To make maintenance of the computer easier, markings of the kinds of the screws including the types and lengths of the screws are indicated on the computer body.

Kind of screws	Symbol
<input type="checkbox"/> BIND screw	B
<input type="checkbox"/> FLAT HEAD screw	F
<input type="checkbox"/> SUPER THIN HEAD screw	S
<input type="checkbox"/> TAPPING screw	T
<input type="checkbox"/> Other screws (Unique screws, STUD, etc.)	U

Examples:

- 6 mm BIND screw B6
- 12 mm BIND screw B12
- 4 mm FLAT HEAD screw F4
(Indicates the screwed length in round number regardless the length of the stud.)

4.2 Battery pack

Removing the Battery pack

To remove the battery pack, follow the steps below and refer to Figure 4-1.

CAUTION: When handling battery packs, be careful not to short circuit the terminals. Also do not drop, hit or apply impact, do not scratch, break, twist or bend the battery pack.

1. Turn off the power of the computer.
2. Disconnect the AC adapter and other external devices from the computer.
3. Turn the computer face down.
4. Release the **battery lock**. Pull out the **battery pack** while sliding the **battery latch** as shown in the following figure.

NOTE: For environmental reasons, do not throw away a spent battery pack.

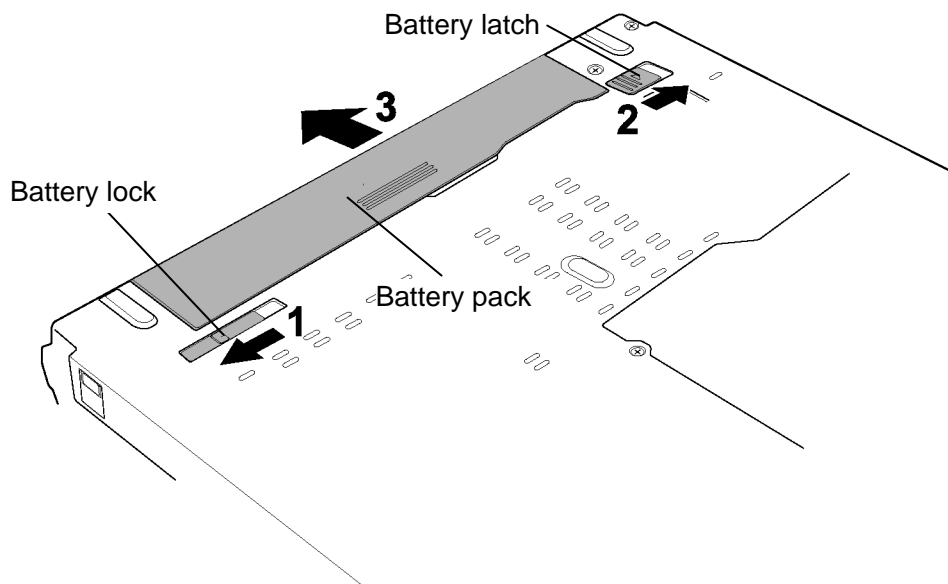

Figure 4-1 Removing the battery pack

Installing the Battery pack

To install the battery pack, follow the steps below and refer to Figure 4-1.

CAUTION: *The battery pack is a lithium ion battery, which can explode if not properly replaced, used, handled or disposed of. For environmental reasons, collect the spent battery packs. Use only batteries recommended by Toshiba for replacements.*

NOTE: *Check the battery's terminals visually. If they are dirty, wipe them clean with a dry cloth.*

1. Turn off the power of the computer.
2. Disconnect the AC adapter and all other external devices to the computer.
3. Push the **battery pack** into the battery slot. Make sure the battery pack is installed securely.
4. Slide the **battery lock** into the lock position.

4.3 PC card

Removing the PC card

To remove the PC card, follow the steps below and refer to Figure 4-2.

CAUTION: Before you remove the PC card, refer to the card's documentation and to your operating system documentation for proper procedures and precautions.

1. Press the **eject button** for the PC card you want to remove to extend the button.
2. Press the extended eject button to pop the PC card out.
3. Grasp the **PC card** and pull it out.

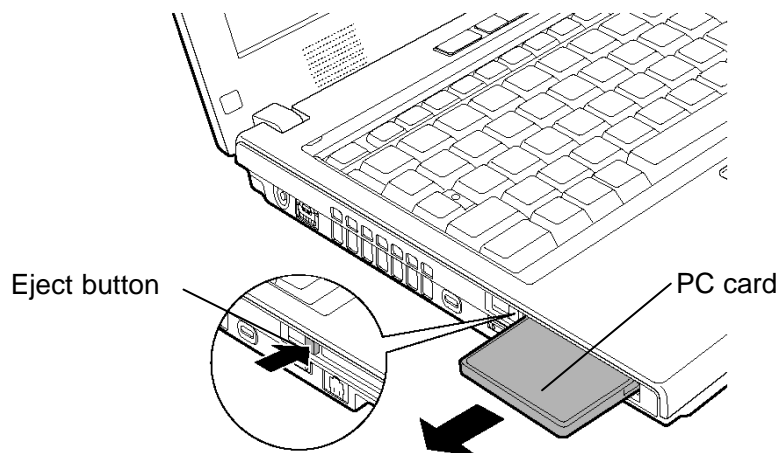

Figure 4-2 Removing the PC card

Installing the PC card

To install the PC card, follow the steps below and refer to Figure 4-2.

1. Insert the **PC card** into the card slot.
2. Push it carefully to ensure a firm connection.

4.4 Bridge media

Removing the Bridge media

To remove the Bridge media, follow the steps below and refer to Figure 4-3.

CAUTION: Before you remove the Bridge media, refer to the card's documentation and to your operating system documentation for proper procedures and precautions.

1. Push the **Bridge media** in and release it to pop the card out.
2. Grasp the **Bridge media** and pull it out.
(For an instance, SD card is described in the figure 4-3.)

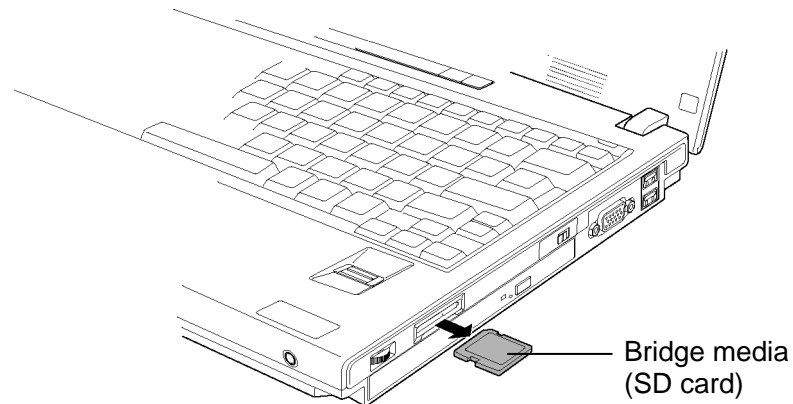

Figure 4-3 Removing the Bridge media (SD card)

Installing the Bridge media

To install the Bridge media, follow the steps below and refer to Figure 4-3.

1. Insert the **Bridge media** in the card slot.
2. Push it carefully to ensure a firm connection.

4.5 HDD

CAUTION: When handling the HDD, do not press the top surface as shown by the arrow. Hold it by the sides.

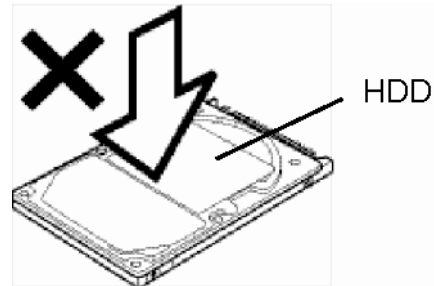

Removing the HDD

To remove the HDD, follow the steps below and refer to Figure 4-4 and 4-5.

1. Turn the computer upside down.
2. Loosen the **screw** (with an e-ring) and remove the **HDD cover** while releasing latches.
3. Pull the **tab** of the **HDD assembly** to remove it from the connector of the HDD cable. Be careful not to damage the connector.

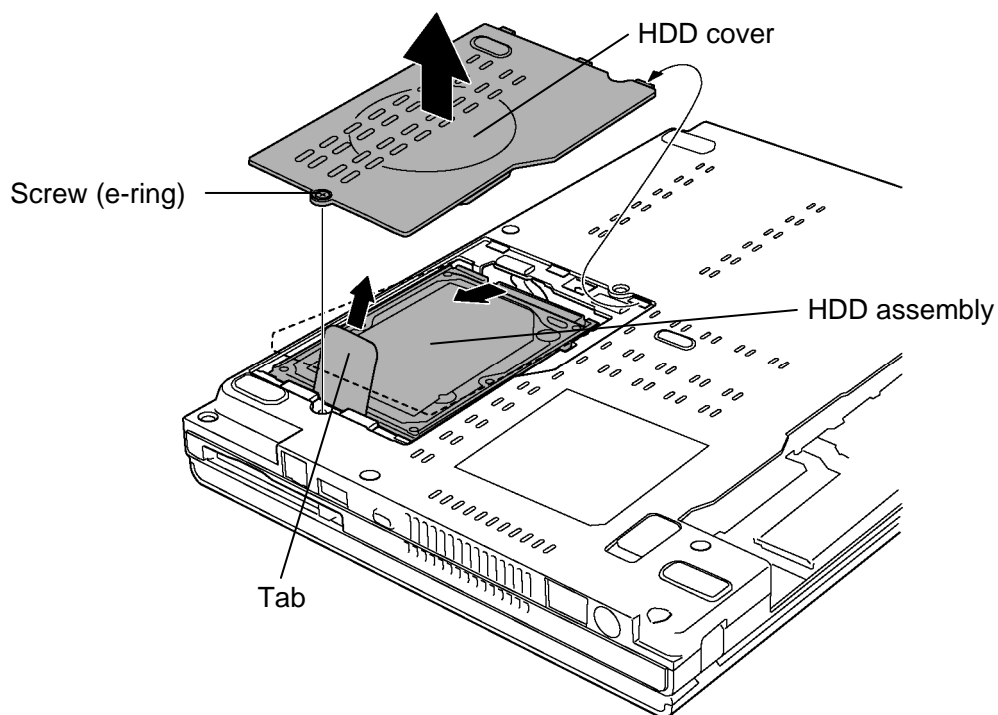

Figure 4-4 Removing the HDD cover

NOTE: The following steps describe how to disassemble the HDD assembly, however, do not disassemble if the HDD is working properly.

4. Place the HDD assembly on a flat surface, and remove the following **screws**.
 - M3×4S FLAT HEAD screw ×4
5. Separate the **HDD** and **HDD Holder**.

CAUTION: Do not apply pressure to the top or bottom of the HDD.

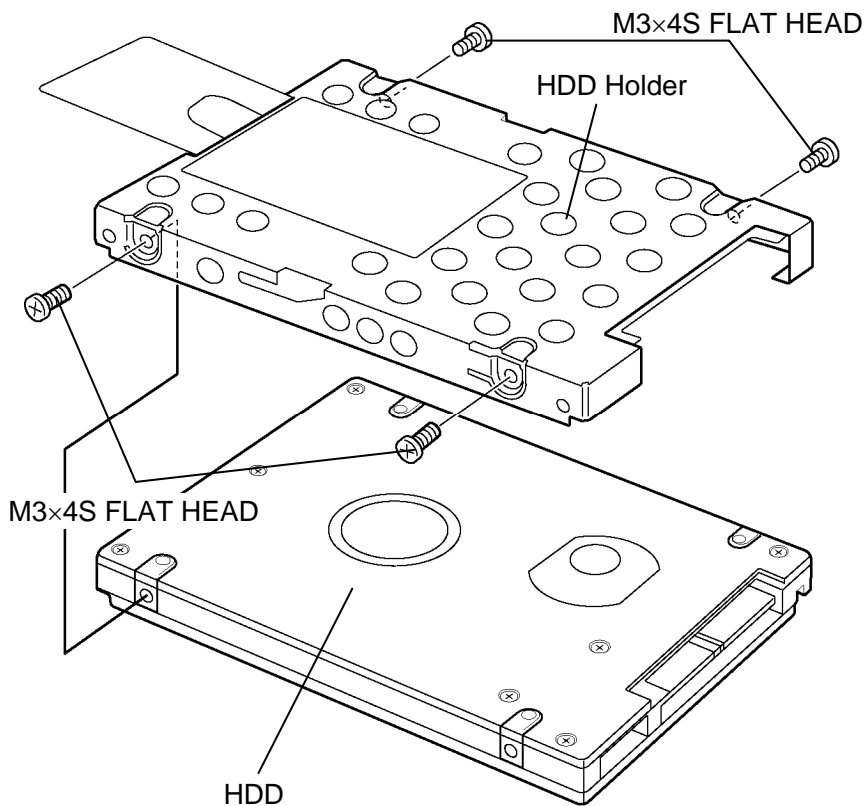

Figure 4-5 Separating the HDD and HDD holder

Installing the HDD

To install the HDD, follow the steps below and refer to Figure 4-4 and 4-5.

CAUTION: Do not hold the HDD by its top and bottom flat surfaces. It may damage the HDD.

1. Seat the **HDD** in the **HDD Holder** and secure them with the following **screws**.

- M3×4S FLAT HEAD screw ×4

CAUTION: Do not apply pressure to the center of the HDD assembly. It may damage the HDD assembly. Hold the HDD assembly by its corners.

2. Set the connector of the **HDD cable** upward and connect firmly the **HDD assembly** to the connector. Lay the **HDD assembly** down in the slot.
3. Set the **HDD cover** and secure it with the **screw** (with an e-ring).

4.6 Optical drive

Removing the Optical drive

To remove the optical drive, follow the steps below and refer to Figure 4-6 and 4-7.

CAUTION: Do not put fingers in the optical drive. It may cause injury.

1. Remove the following two **screws** securing the slim select.
 - M2.5×4B FLAT HEAD screw ×1
 - M2.5×16B FLAT HEAD screw ×1
2. While sliding the **hook** in the direction of the arrow in the figure below, remove the **optical drive** (from connector on the system board).

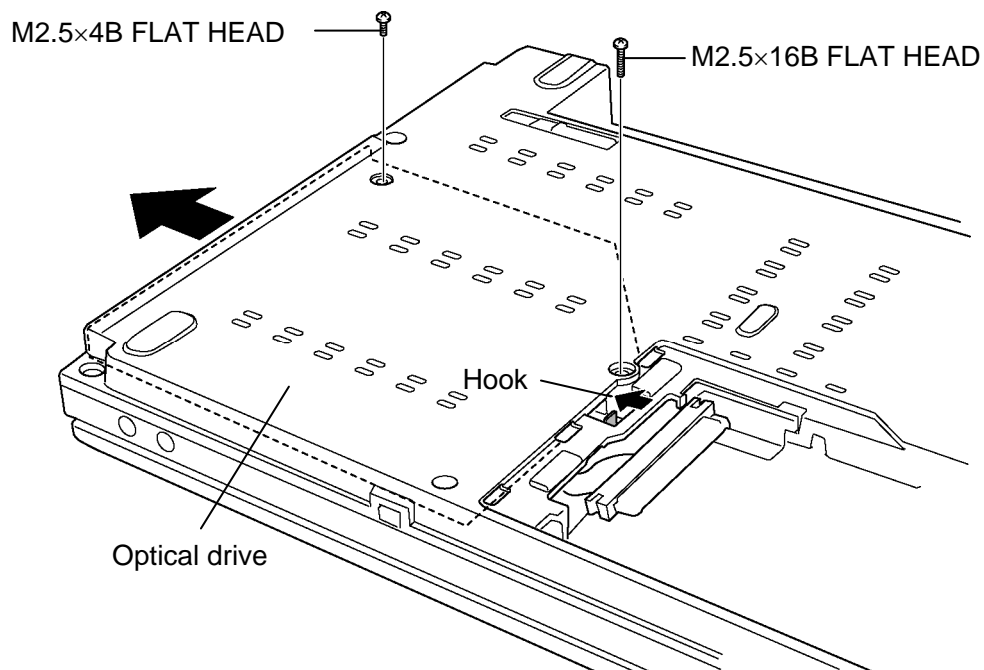

Figure 4-6 Removing the optical drive

3. Remove the following **screw** and the **pushing plate**.
 - M2×3S S-THIN HEAD screw ×2
4. Remove the following **screws** and the **mounting plate**.
 - M2×3B BIND screw ×1

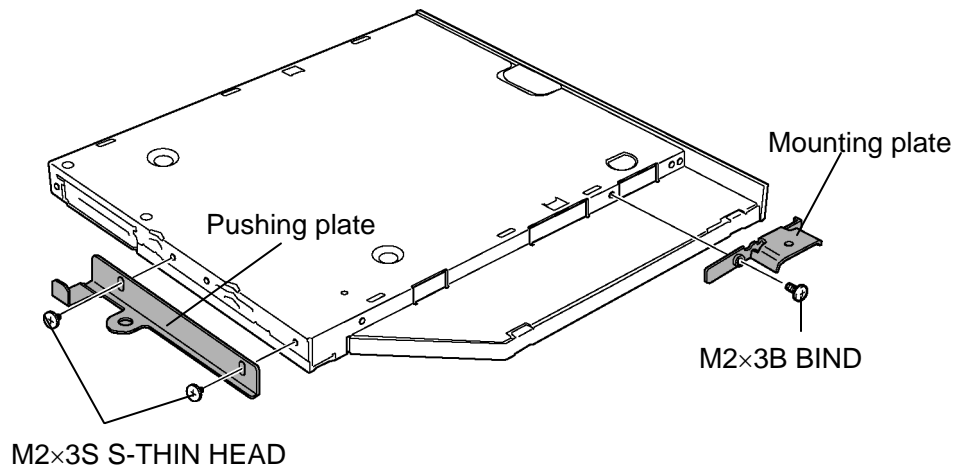

Figure 4-7 Disassembling the optical drive

Installing the Optical drive

To install the optical drive, follow the steps below and refer to Figure 4-6 and 4-7.

1. Set the **mounting plate** and secure it with the following **screw**.
 - M2×3B BIND screw ×1
2. Set the **pushing plate** and secure it with the following **screws**.
 - M2×3S S-THIN HEAD screw ×2
3. Insert the **optical drive** firmly into the computer to connect it to the connector on the system board.
4. Secure the **optical drive** with the following **screws**.
 - M2.5×4B FLAT HEAD screw ×1
 - M2.5×16B FLAT HEAD screw ×1

CAUTION: When inserting the slim select bay module, turn the computer face up and insert it while slightly pressing it down.

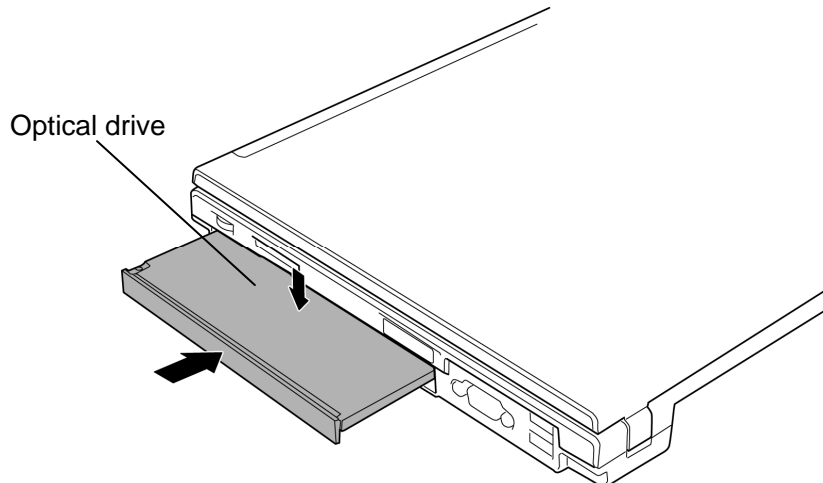

4.7 Keyboard

Removing the Keyboard

To remove the keyboard, follow the steps below and refer to Figure 4-8 and 4-9.

1. Turn over the computer and open the display.
2. Insert your fingers into the slits on both sides and lift up the **keyboard holder** to remove.
3. Remove the following **screws** securing the keyboard.

- M2×3S S-THIN HEAD screw ×2

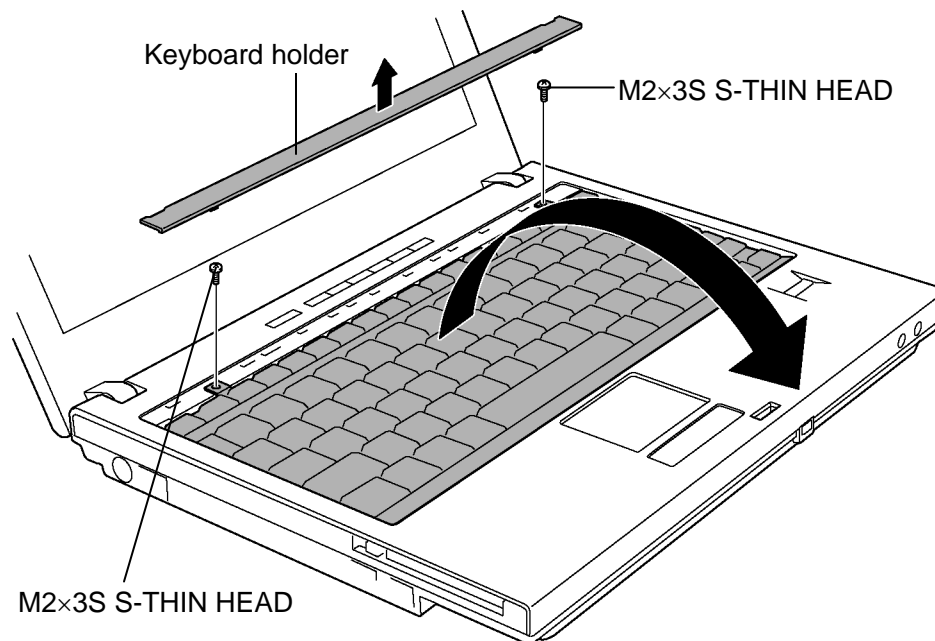

Figure 4-8 Removing the keyboard holder

4. Remove the following **screws** and **keyboard support plate**.
 - M2.5×8B FLAT HEAD screw ×1
5. Disconnect the **keyboard cable** from the connector **CN3230** on the system board and remove the **keyboard**.

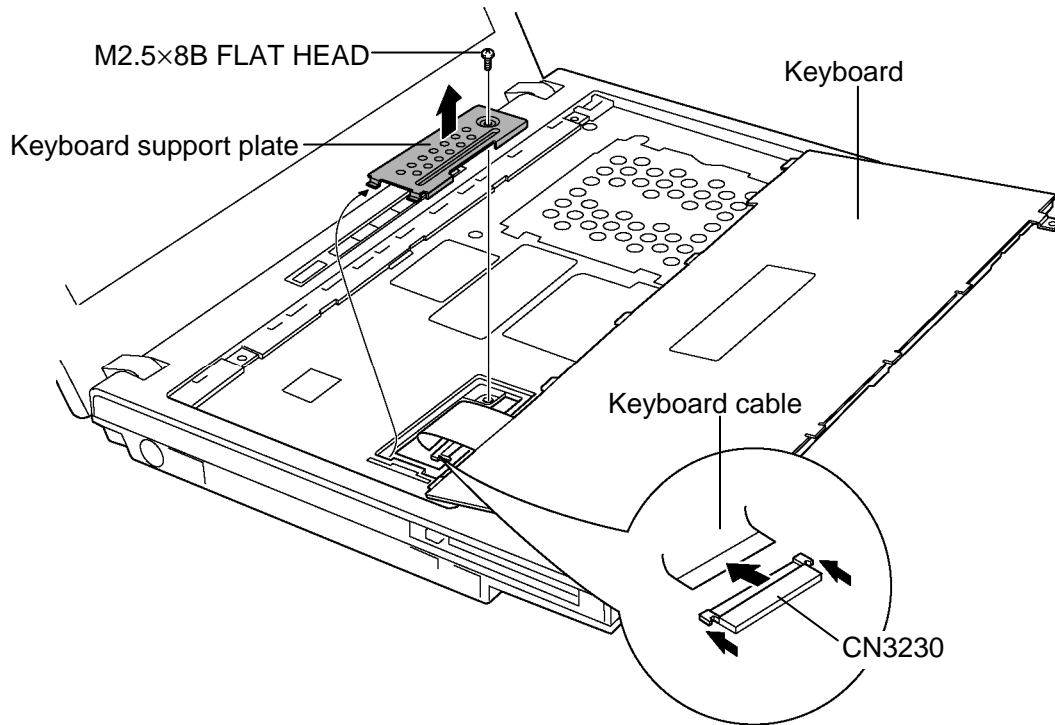

Figure 4-9 Removing the keyboard support plate

Installing the Keyboard

To install the keyboard, follow the steps below and refer to Figure 4-8 and 4-9.

1. Place the keyboard face down on the palm rest.
2. Connect the **keyboard cable** to the connector **CN3230** on the system board.
3. Install the **keyboard support plate** and secure it with the following **screw**.
 - M2.5×8B FLAT HEAD screw ×1
4. Turn the **keyboard** face up and set it in place.
5. Secure the **keyboard** with the following **screws**.
 - M2×3S S-THIN HEAD screw ×2
6. Install the **keyboard holder** and press to secure the latches.

4.8 Memory module

Removing the Memory module

CAUTION: The power must be turned off when you remove or insert a memory module. Inserting a memory module with the power on might damage the module or the computer itself.

Never press hard or bend the memory module.

To remove the memory module, make sure the computer is in boot mode and powered off, follow the steps below and refer to Figure 4-10.

1. Remove the following **screws** and **memory cover**.
 - M2.5×3S S-THIN HEAD screw ×2
2. Press two **latches** outward to release them.
3. Grasp both sides of the **memory module** and lift it up slantwise to remove.

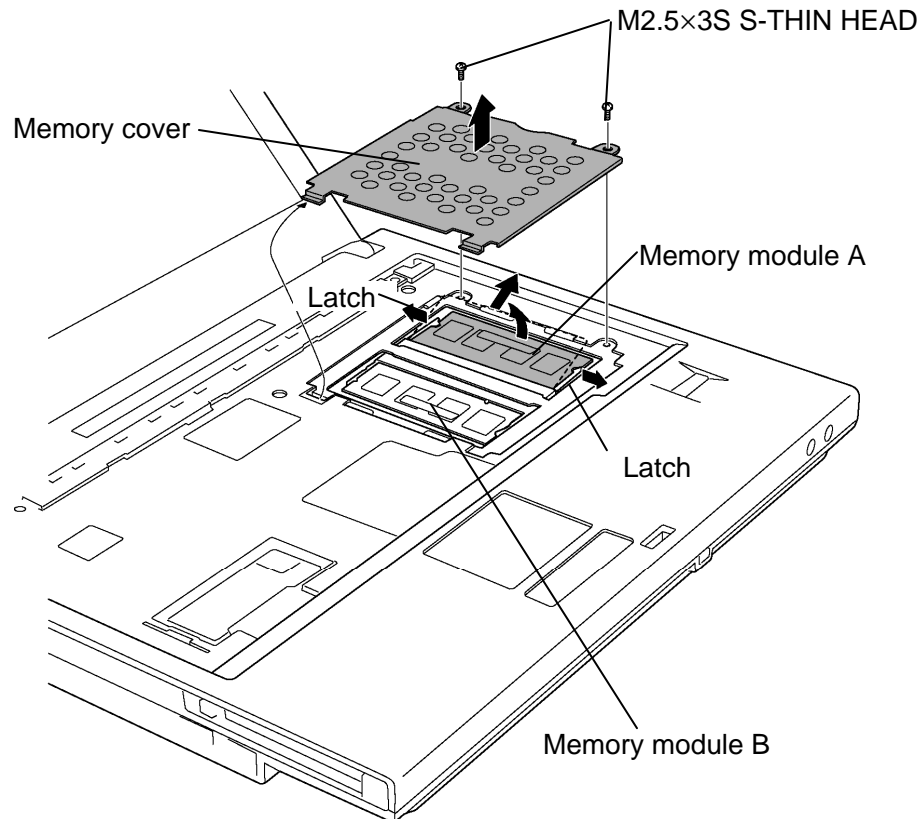

Figure 4-10 Removing the memory module

Installing the Memory module

To install the memory module, make sure that the computer is in boot mode and powered off, follow the steps below and refer to Figure 4-10.

CAUTION: *When installing only one memory module, be sure to insert it into the slot A. Otherwise, the computer or the memory may not work properly.*

Do not touch the connectors on the memory module or on the computer. Dust and stains on the connectors may cause memory access problems.

1. Insert the **memory module** into the connector slantwise and press it to connect firmly.
2. Press down the memory module until it is latched firmly.
3. Seat the **memory cover** and secure it with the following **screws**.
 - M2.5×3S S-THIN HEAD screw ×2

NOTE: *When the power of computer is turned on, the computer checks automatically the memory size. Confirm that the new memory is detected correctly. If the memory is not detected, check that it is connected correctly.*

4.9 Cover FAT assembly

Removing the Cover FAT assembly

To remove the Cover FAT assembly, follow the steps below and refer to Figure 4-11 to 4-14.

1. Peel off the **insulator** that prevents a waterdrop from entering the computer and disconnect the **SW membrane cable** from the connector **CN3260** on the system board.
2. Peel off the **insulator** that prevents a waterdrop from entering the computer and disconnect the **touch pad cable** and **fingerprint sensor cable** from the connector **CN3240** and **CN9520** on the system board.

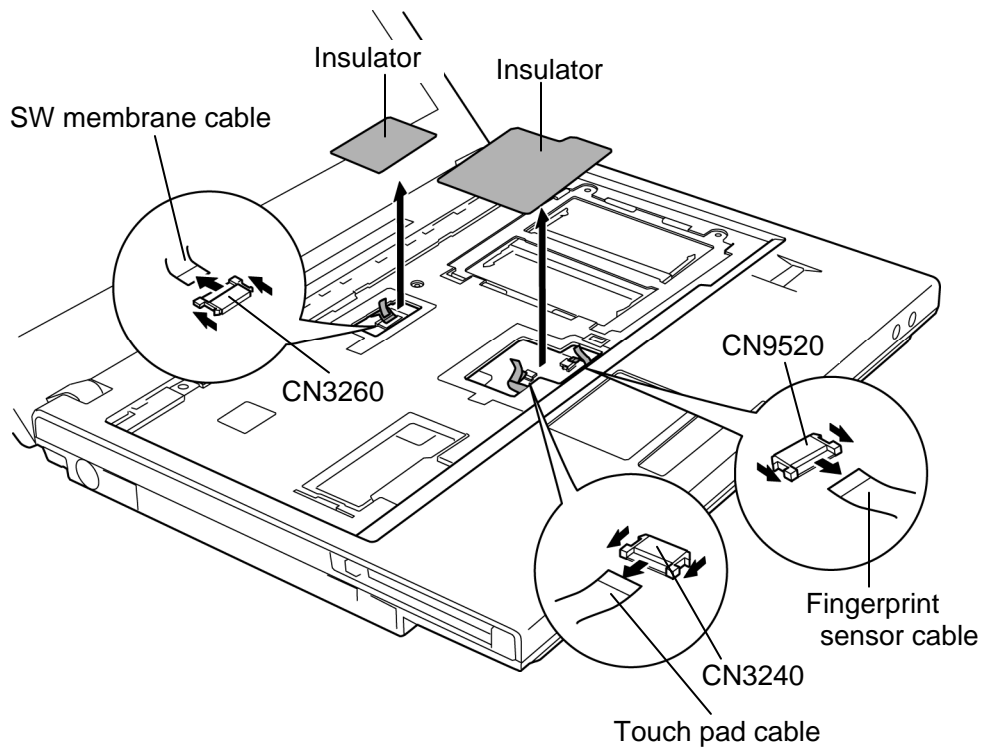

Figure 4-11 Removing the Cover FAT assembly (1)

3. Remove following screws.

- M2.5×8B FLAT HEAD screw ×2

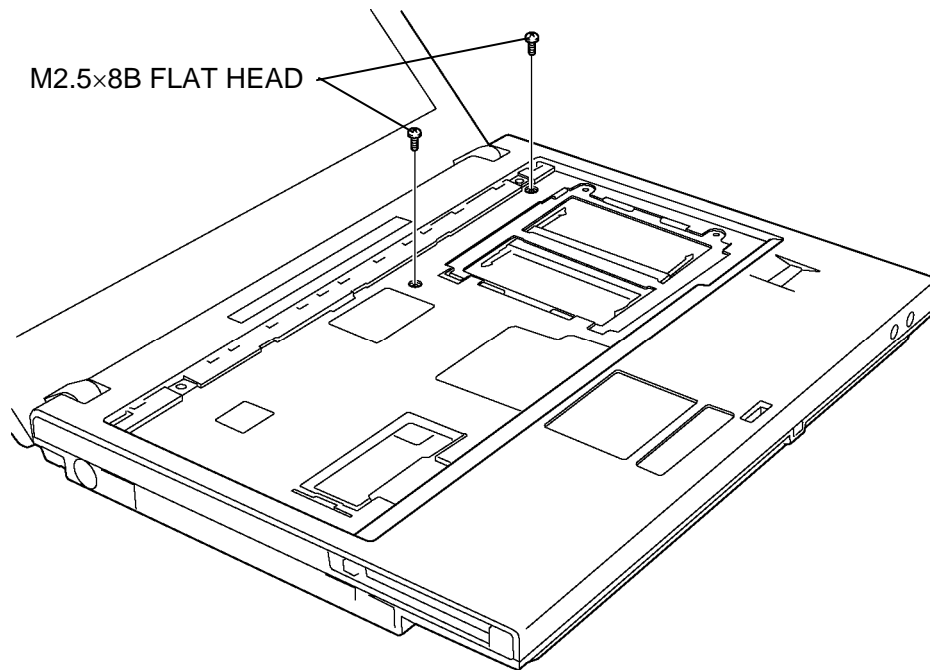

Figure 4-12 Removing the Cover FAT assembly (2)

4. Turn the computer face down and remove the following **screws** on the bottom.
- M2.5×8B FLAT HEAD screw ×7 (“8” in the figure below)
 - M2.5×16B FLAT HEAD screw ×1 (“16” in the figure below)

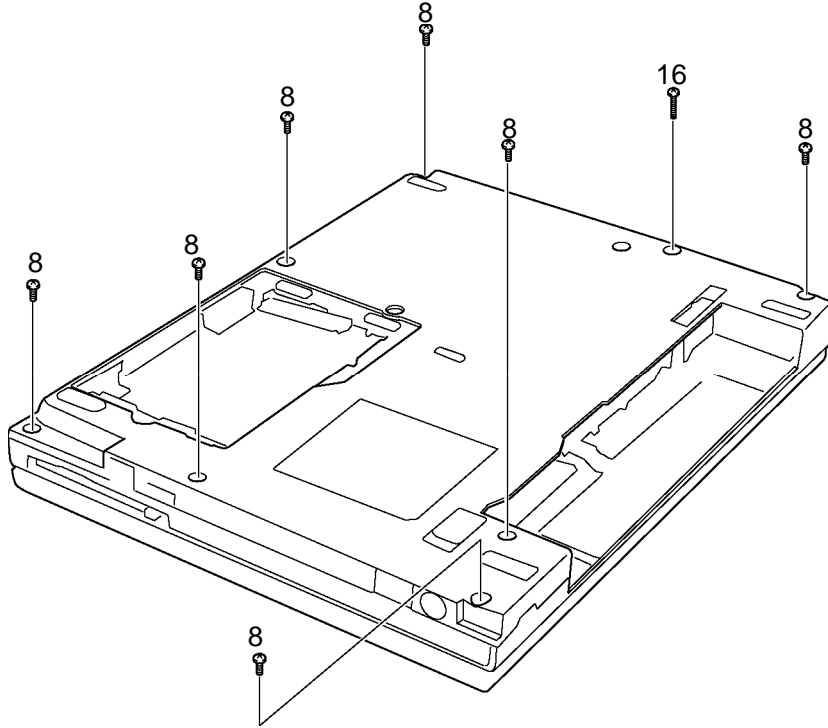

Figure 4-13 Removing the Cover FAT assembly (3)

5. Turn the computer face up and open the display.
6. While releasing the latches on both sides lift up the **Cover FAT assembly** to remove.

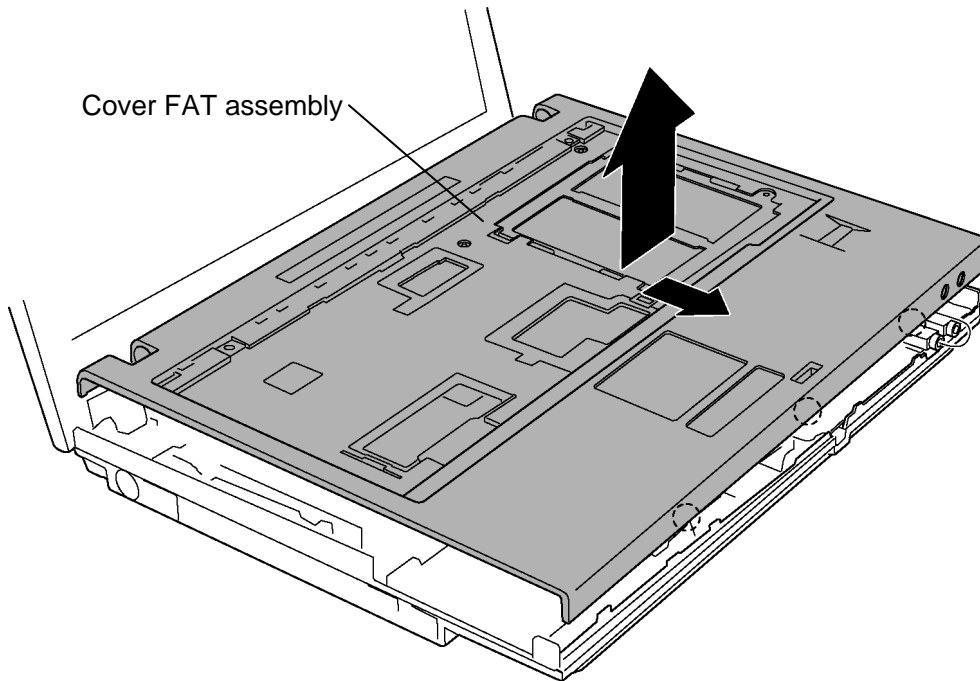

Figure 4-14 Removing the Cover FAT assembly (4)

Installing the Cover FAT assembly

To install the Cover FAT assembly, follow the steps below and refer to Figure 4-11 to 4-14.

1. Place the **Cover FAT assembly** on the **base assembly** and secure the latches.

CAUTION: When installing Cover FAT assembly, insert the guides of the cover FAT assembly into the base as shown in the following figure.

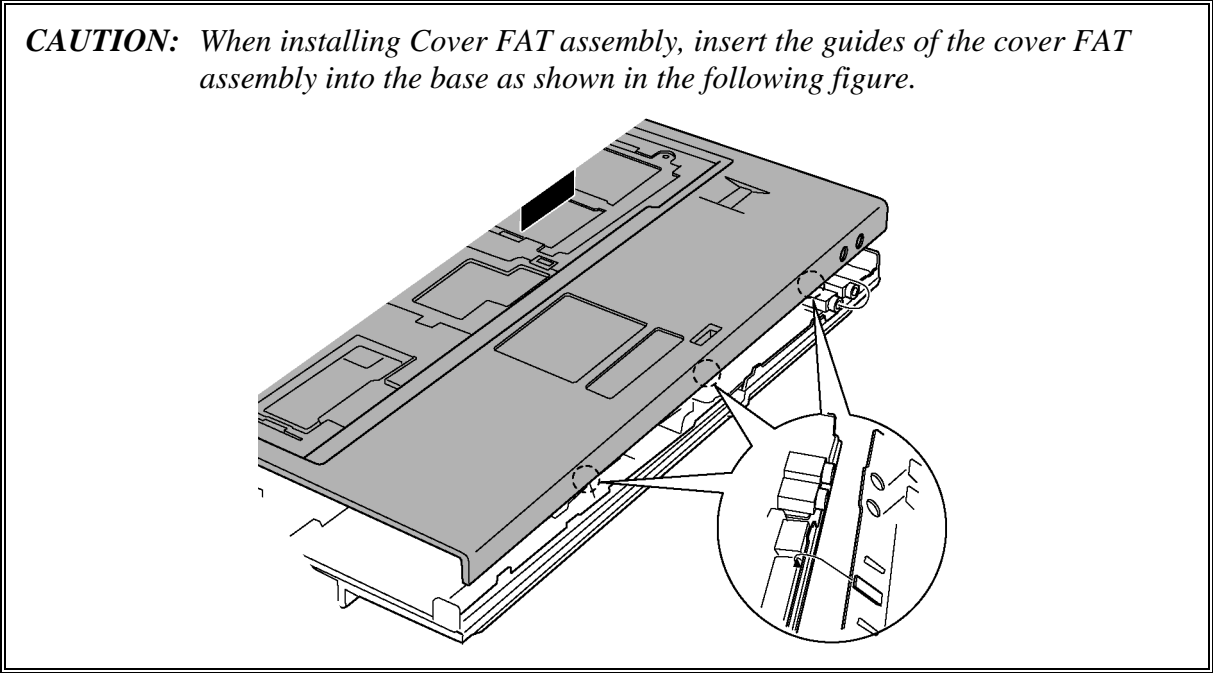

2. Secure the **Cover FAT assembly** with the following screws.
 - M2.5×8B FLAT HEAD screw ×2
3. Turn the computer face up.
4. Connect the **SW membrane cable** to the connector **CN3260** on the system board and stick a new **insulator**.
5. Connect the **touch pad cable** and **fingerprint sensor cable** to the connector **CN3240** and **CN9520** on the system board and stick a new **insulator**.

CAUTION: Do not reuse the removed insulators.

6. Close the display and turn the computer face down. Secure the Cover FAT assembly with the following screws.
 - M2.5×8B FLAT HEAD screw ×7
 - M2.5×16B FLAT HEAD screw ×1

4.10 Fingerprint sensor board

Removing the Fingerprint sensor board

To remove the fingerprint sensor board, follow the steps below and refer to Figure 4-15.

1. Lift up the **hook** and remove the **bracket** while sliding it in the direction of arrow in the figure below.
2. Remove the **fingerprint sensor board** fixed with the **double-sided tape** and peel off the tape that prevents a waterdrop from entering the computer.
3. Disconnect the **fingerprint sensor cable** from the connector on the fingerprint sensor board.

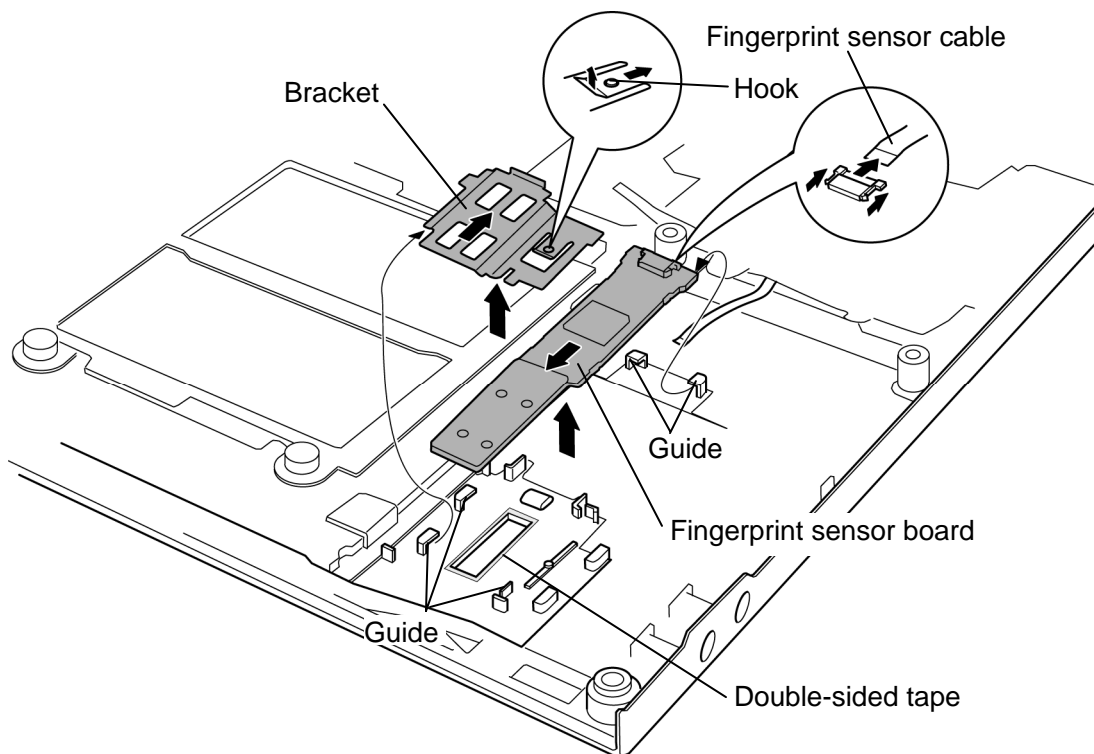

Figure 4-15 Removing the fingerprint sensor board

Installing the Fingerprint sensor board

To install the fingerprint sensor board, follow the steps below and refer to Figure 4-15.

1. Connect the **fingerprint sensor cable** to the connector on the fingerprint sensor board.
2. Stick a new **double-sided tape** in place and install the **fingerprint sensor board** while inserting it under the **guides**.

CAUTION: Do not reuse the removed double-sided tape.

3. Place the **bracket** while sliding it under the **guides** and inserting the slit into the **guide**.

4.11 Touch pad

Removing the Touch pad

To remove the touch pad, follow the steps below and refer to Figure 4-16.

1. Remove the following **screws** securing the **touch pad assembly**.
 - M2×4B BIND screw ×4
2. Remove the **touch pad cover** and **touch pad** (fixed with the double sided tape).
3. Peel off the **double-sided tape** that prevents a waterdrop from entering the computer.
4. Remove the **fingerprint sensor cable** on the touch pad.
5. Open the **insulator** and disconnect **touch pad cable** from the touch pad assembly.

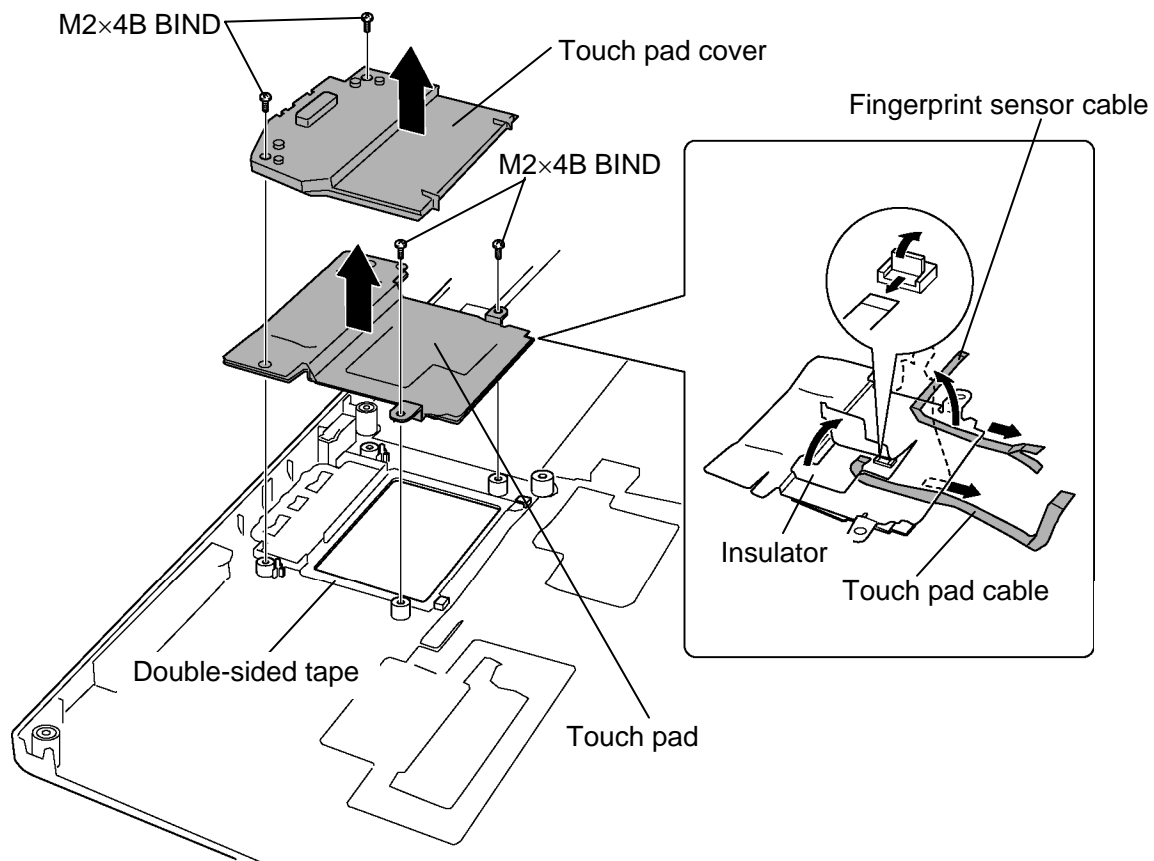

Figure 4-16 Removing the touch pad assembly

Installing the Touch pad

To install the touch pad, follow the steps below and refer to Figure 4-16.

1. Open the **insulator** and connect the **touch pad cable** to the connector on the touch pad assembly.
2. Seat the **fingerprint sensor cable** on the touch pad.
3. Stick a new **double-sided tape** in place.

CAUTION: Do not reuse the removed double-sided tape.

4. Install a new **touch pad** to the slot and **touch pad cover** on it.

CAUTION: Do not reuse the removed touch pad.

5. Secure the **touch pad assembly** with the following **screws**.
 - M2×4B BIND screw ×4

4.12 SW membrane

Removing the SW membrane

To remove the SW membrane, follow the steps below and refer to Figure 4-17 and 4-18.

1. Lift up the **hook** and slide the **SW membrane holder** in the direction of the arrow in the figure to remove it.

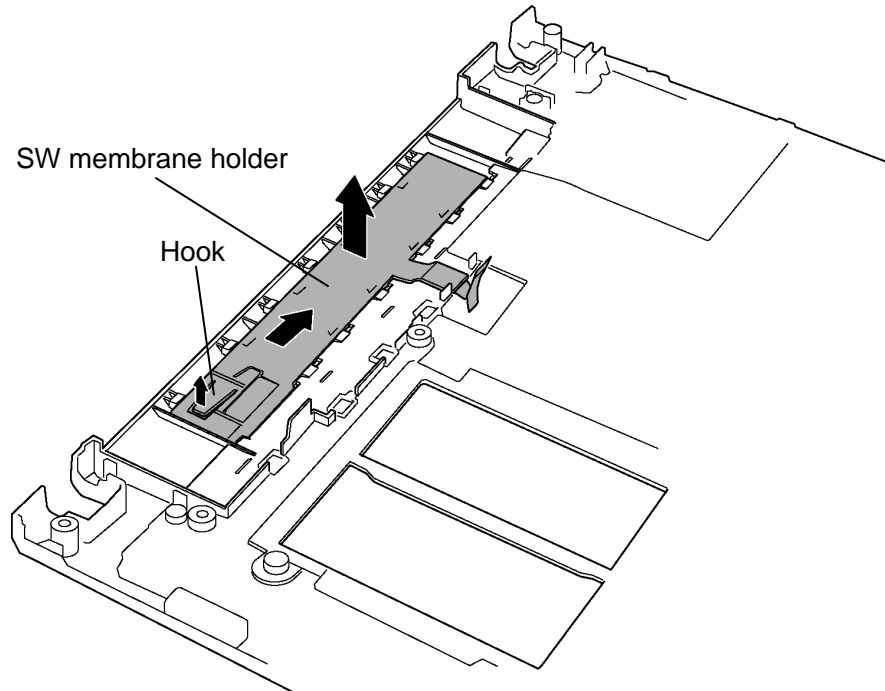

Figure 4-17 Removing the SW membrane (1)

2. Push down the **hook** and slide the **SW membrane** in the direction in the figure below.
3. Remove the **SW membrane**.

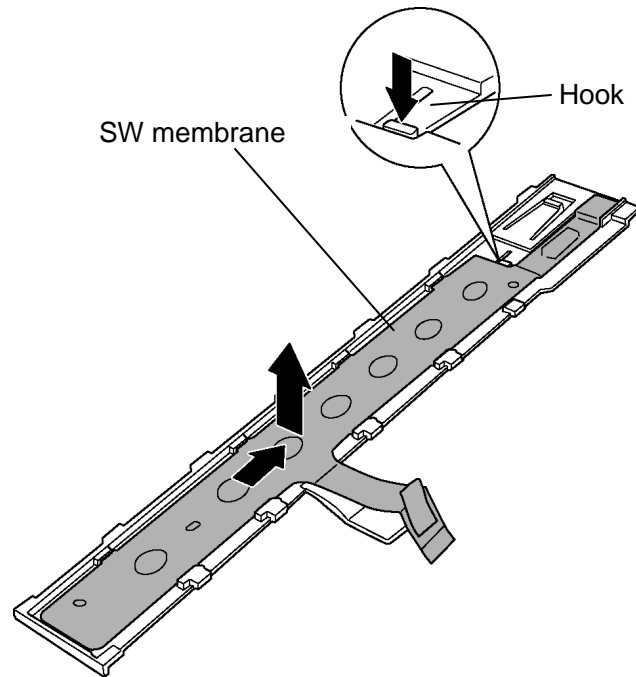

Figure 4-18 Removing the SW membrane (2)

Installing the SW membrane

To install the SW membrane, follow the steps below and refer to Figure 4-17 and 4-18.

1. Install the **SW membrane** in the **SW membrane holder** while sliding it in the opposite direction at removing.
2. Install the **SW membrane holder** (with the SW membrane) to the slot while sliding it in the opposite direction at removing.

4.13 Bluetooth module

Removing the Bluetooth module

To remove the Bluetooth module, follow the steps below and refer to Figure 4-19.

1. Remove the following **screws** to remove the **Bluetooth module**.
 - M2×4B FLAT HEAD screw ×1
2. Disconnect the **Bluetooth cable** from the connector **CN4400** on the system board.
3. Disconnect the **Bluetooth cable** and **Bluetooth antenna cable** from the connector on the Bluetooth module.

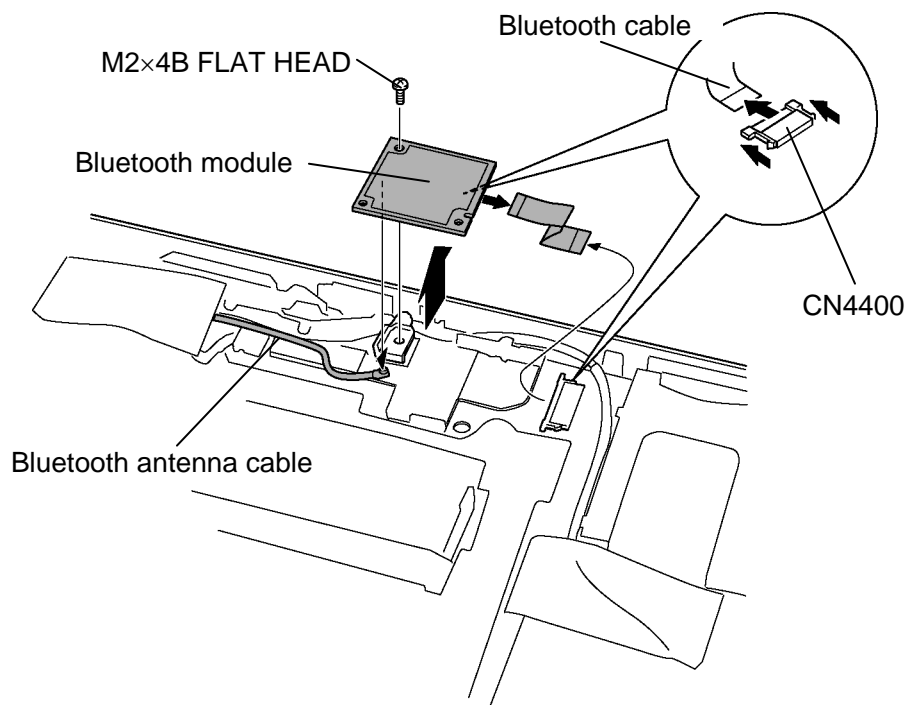

Figure4-19 Removing the Bluetooth module

Installing the Bluetooth module

To install the Bluetooth module, follow the steps below and refer to Figure 4-19.

1. Connect the **Bluetooth cable** and **Bluetooth antenna cable** to the connector on the Bluetooth module.
2. Connect the **Bluetooth cable** to the connector **CN4400** on the system board.
3. Secure the **Bluetooth module** with the following **screws**.
 - M2×4B FLAT HEAD screw ×1

4.14 Wireless LAN card

Removing the Wireless LAN card

To remove the wireless LAN card, follow the steps below and refer to Figure 4-20.

1. Peel off the **glass tape**.
2. Disconnect the **wireless LAN antenna cables** (black and white) from the wireless LAN card using an antenna coaxial cable disconnecter.
3. Remove the following **screws** and **wireless LAN card cover**.
 - M2×4B BIND screw ×1
 - Security torx screw or M2×4B BIND screw ×1

NOTE: In models with 11ch type of 802.11 a/b/g wireless LAN card, the wireless LAN card cover and security torx screw are used.

4. With grasping both the sides, disconnect the **wireless LAN card** from the connector **CN2600** on the system board.

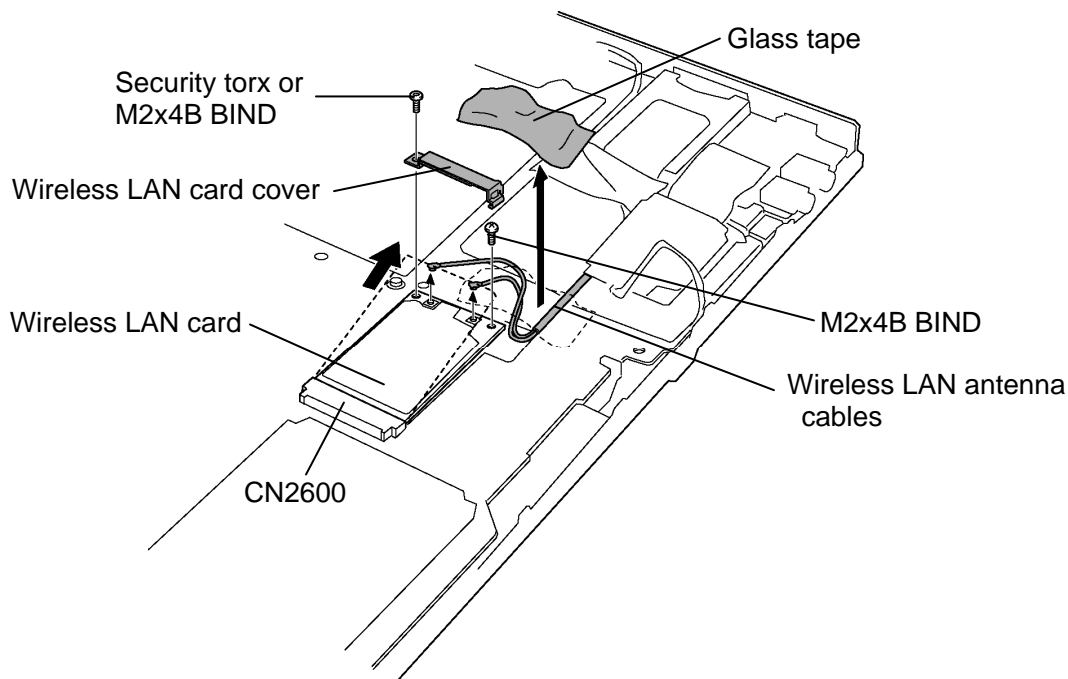

Figure 4-20 Removing the wireless LAN card

Installing the Wireless LAN card

To install the wireless LAN card, follow the steps below and refer to Figure 4-20.

1. Insert slantingly the **wireless LAN card** into the connector **CN2600** on the system board.
2. Gently push the **wireless LAN card** down and secure the wireless LAN card with the following **screw**.
 - M2×4B BIND screw ×1
3. Seat the **wireless LAN card cover** in place and secure it with the following **screw**.
 - Security torx screw or M2×4B BIND screw ×1
4. Connect the **wireless LAN antenna cables** (black and white) to the connectors on the wireless LAN card.
5. Stick the **glass tape**.

4.15 MDC (Modem Daughter Card)

Removing the MDC

To remove the MDC, follow the steps below and refer to Figure 4-21.

1. Remove the following **screws** securing the MDC.

- M2×4B BIND screw ×2

CAUTION: When removing the MDC, lift it up right above. Otherwise, the MDC or connector may be damaged.

2. Lift up the **MDC** to disconnect it from the connector **CN3010** on the system board.
3. Disconnect the **modem cable** from the connector on the MDC.

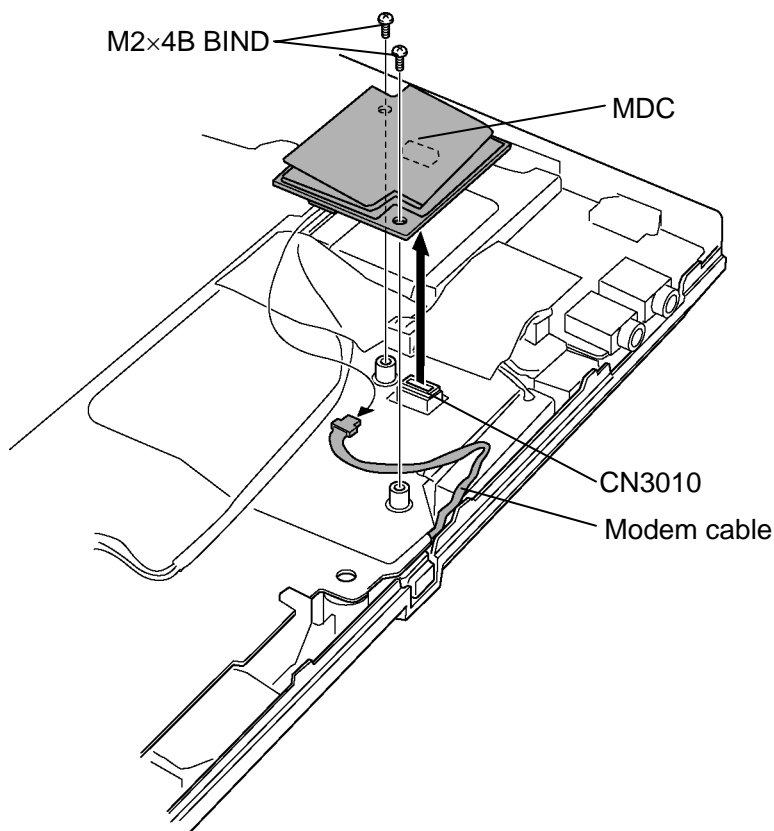

Figure 4-21 Removing the MDC (Modem Daughter Card)

Installing the MDC

To install the MDC, follow the steps below and refer to Figure 4-21.

1. Connect the **modem cable** to the connector on the MDC.
2. Set the **MDC** and press it carefully to connect it to the connector **CN3010** on the system board. Be careful not to damage the MDC and connector.
3. Secure the MDC with the following **screws**.
 - M2×4B BIND screw ×2

4.16 Internal microphone

Removing the Internal microphone

To remove the internal microphone, follow the steps below and refer to Figure 4-22.

1. Peel off the **glass tape** and take out the **microphone holder**.
2. Disconnect the **microphone cable** from the connector **CN6050** on the system board and take out the **internal microphone** from the slot.

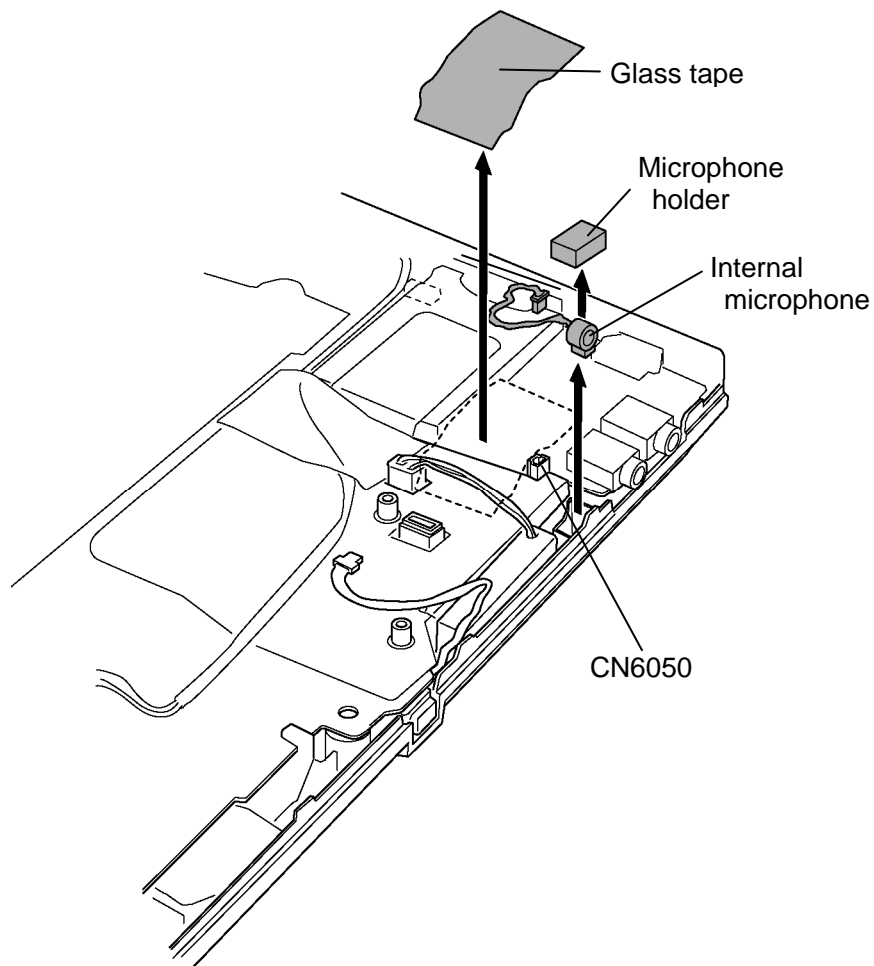
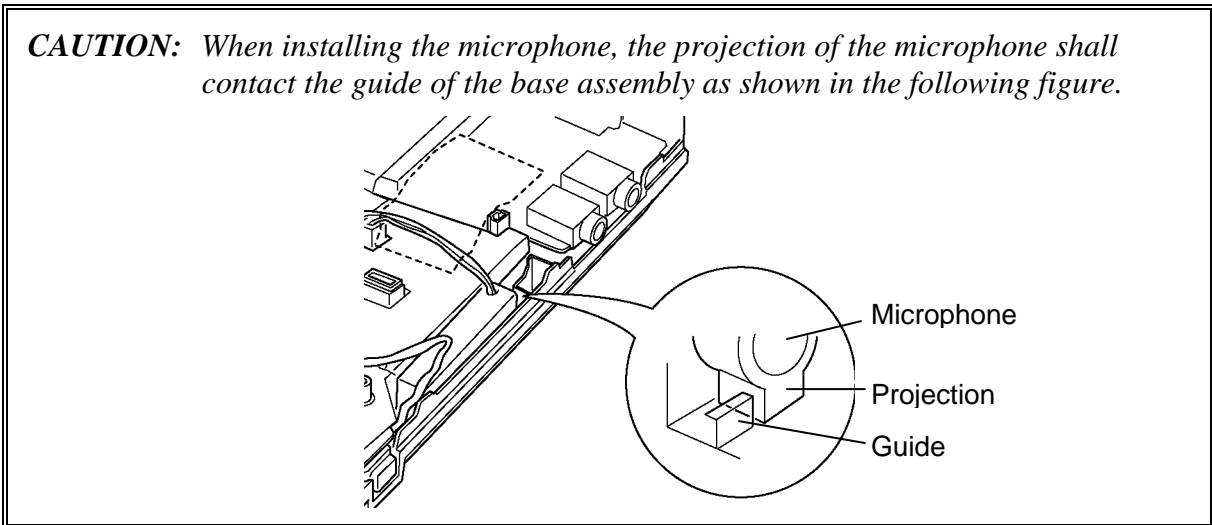

Figure 4-22 Removing the internal microphone

Installing the Internal microphone

To install the internal microphone, follow the steps below and refer to Figure 4-22.

1. Install the **internal microphone** and **microphone holder** to the slot of the front panel.



2. Connect the **microphone cable** to the connector **CN6050** on the system board
3. Stick the **glass tape** on the microphone cable.

4.17 RTC battery

WARNING: When replacing the RTC battery, be sure to use a genuine battery authorized by Toshiba. Installing the wrong battery could cause a battery explosion or other damage.

If the RTC battery is found abnormal, it must not be installed. Replace it with a new battery, and dispose of the old one according to the local regulations.

Check for any of the following signs of damage:

1) Electrolyte leakage

- Corrosion (greenish color) on the battery connector or cable
- Corrosion on the computer's battery connector
- White powder on any part of the battery
- White powder in the battery tray
- Clear liquid on the battery
- Clear liquid in the battery tray
- Clear liquid on any board near the battery

2) Damage to the connection cable

3) Damage to the connector housing

If any powder or liquid is found in or around the battery tray, clean it. Be careful not to let any leaked material contact your eyes or mouth. Do not inhale fumes from leaked material.

If leaked material contacts your skin, eyes or mouth, wash the affected area thoroughly with clean water.

Removing the RTC battery

To remove the RTC battery, follow the steps below and refer to Figure 4-23.

1. Disconnect the **RTC battery cable** from the connector **CN9300** on the system board.
2. Open the **insulator** and remove the **RTC battery**.

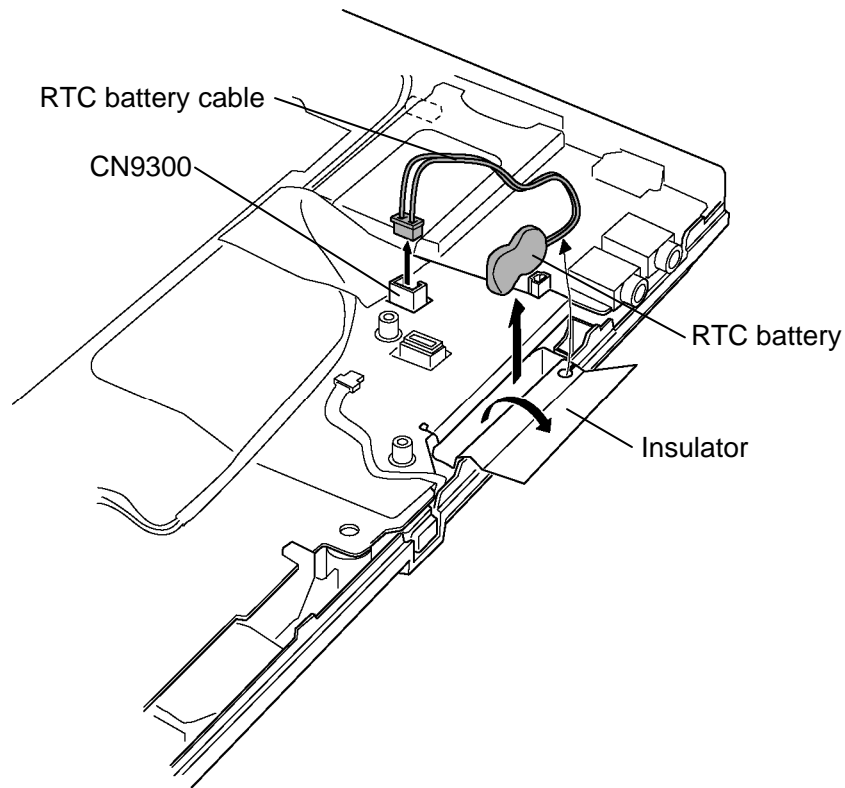

Figure 4-23 Removing the RTC battery

Installing the RTC battery

To install the RTC battery, follow the steps below and refer to Figure 4-23.

1. Set the **RTC battery** in place and wrap it with the **insulator**.
2. Connect the **RTC battery cable** to the connector **CN9300** on the system board.

4.18 Harness holder / LAN cable

To remove the Harness holder / LAN cable, follow the steps below and refer to Figure 4-24 and 4-25.

1. Disconnect the **LCD cable** and **LAN cable** from the connectors **CN5000** and **CN4100** on the system board.
2. Remove the following **screw** securing the harness holder.
 - M2.5×4B FLAT HEAD screw ×1

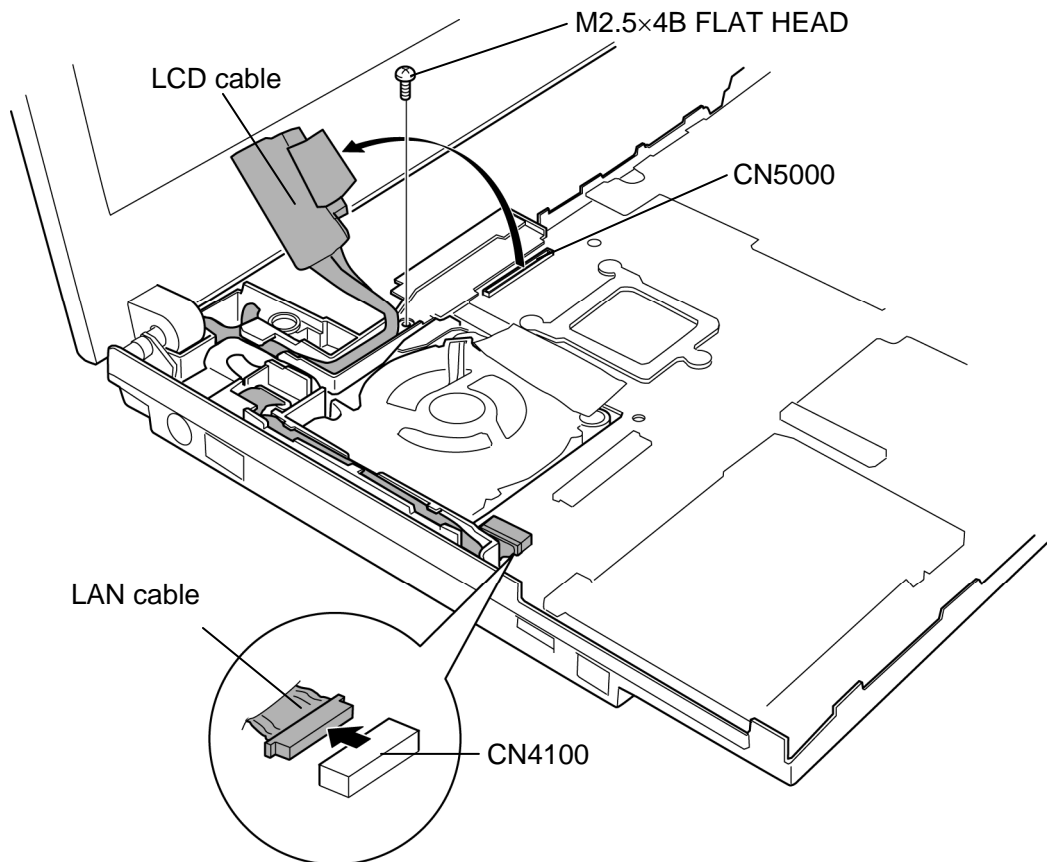

Figure 4-24 Removing the Harness holder / LAN cable (1)

3. Take out the **LAN cable** from the harness holder.
4. Remove the **harness holder** while lifting up the LCD cable and LAN cable.
5. Take out the **LAN jack** from the LAN jack slot.

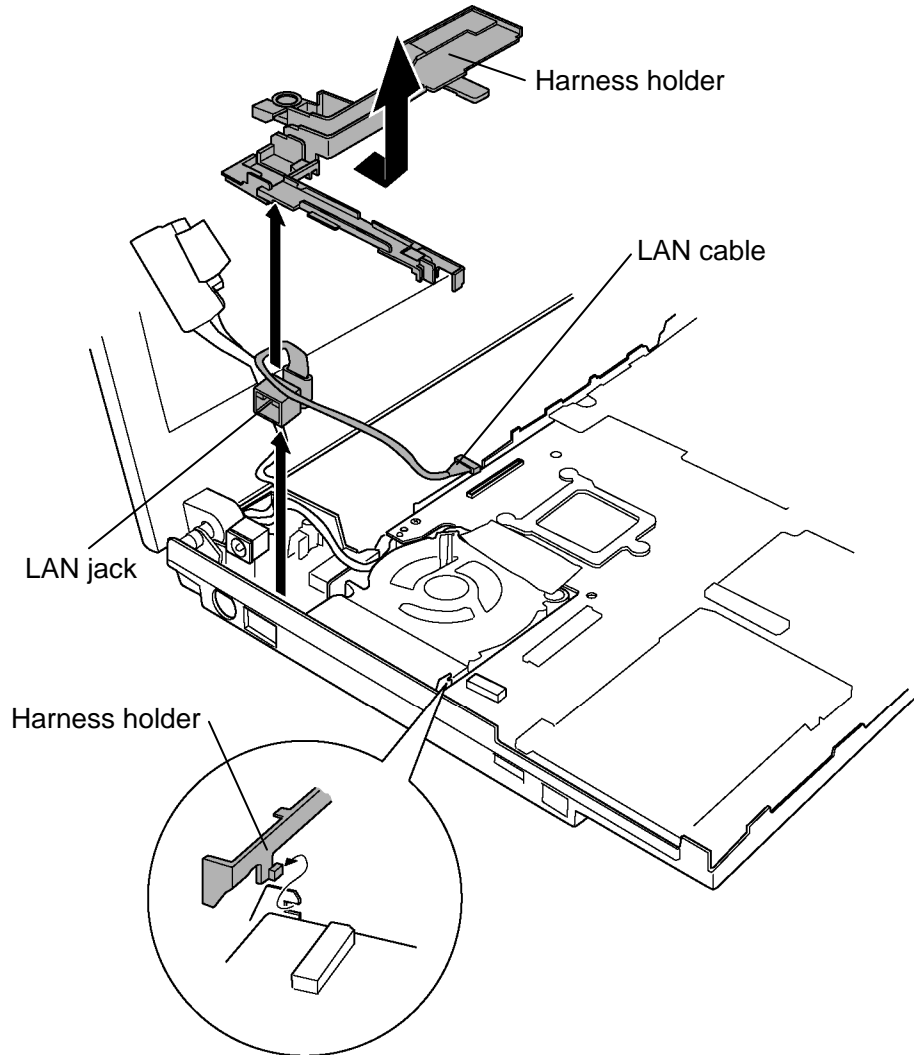

Figure 4-25 Removing the Harness holder / LAN cable (2)

Installing the Harness holder / LAN cable

To install the Harness holder / LAN cable, follow the steps below and refer to Figure 4-24 and 4-25.

1. Install the **LAN jack** into the slot.
2. Pass the **LCD cable** and **LAN cable** in the guide of the harness holder and install the **harness holder** and secure it with the following screw.
 - M2.5×4B FLAT HEAD screw ×1

CAUTION: When passing the LCD cable and LAN cable, refer to the following figure.

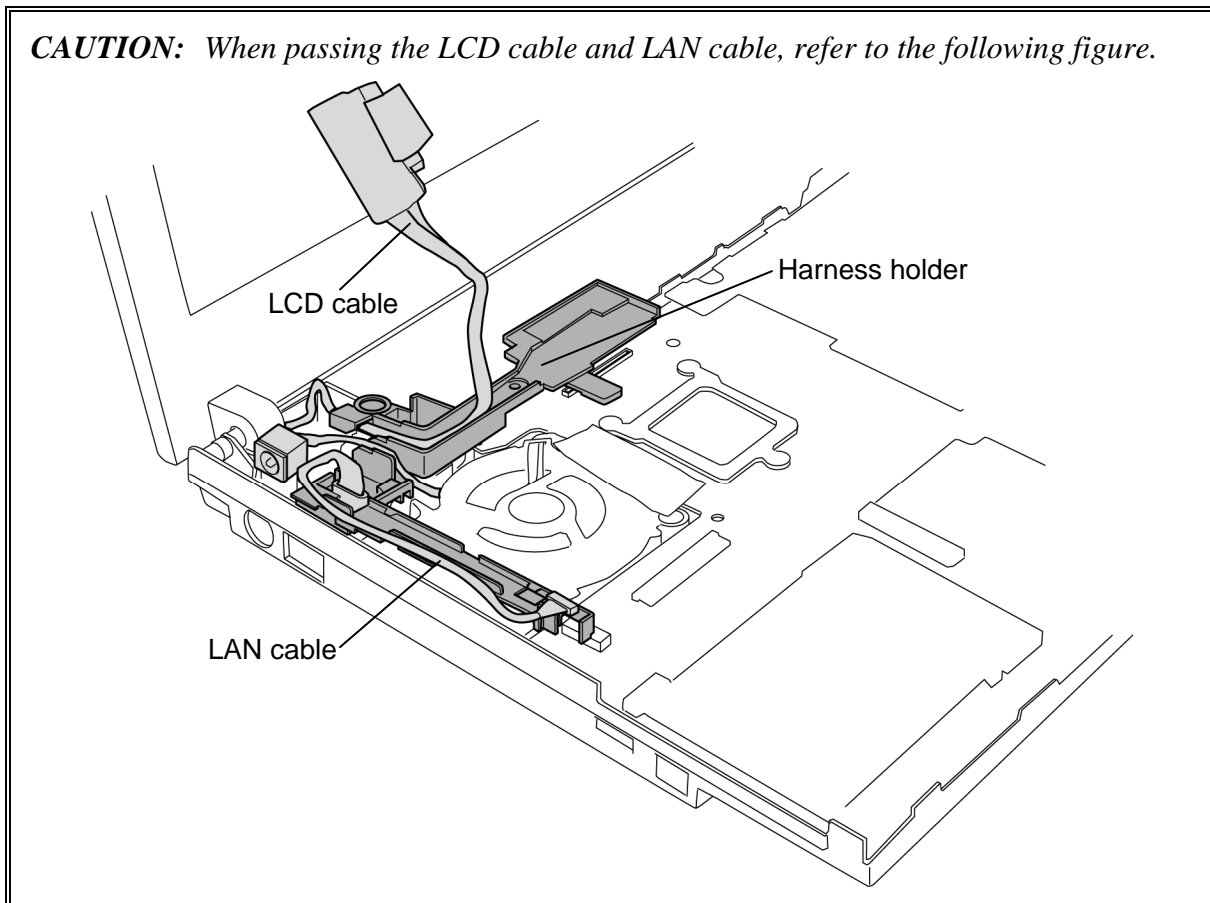

3. Connect the **LCD cable** and **LAN cable** to the connectors **CN5000** and **CN4100** on the system board.

4.19 System board / DC-IN jack

To remove the System board / DC-IN jack, follow the steps below and refer to Figure 4-26 to 4-28.

1. Remove two **glass tapes** on the wireless LAN antenna cable and speaker cable.
2. Disconnect the **speaker cable** from the connector **CN6170** on the system board.

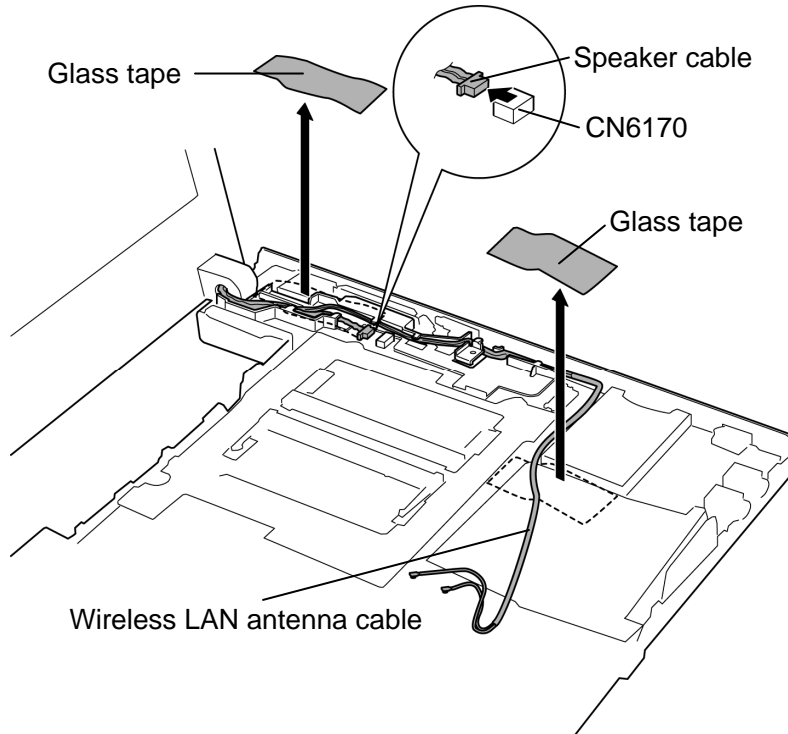

Figure 4-26 Removing the System board / DC-IN jack (1)

3. Take out the **DC-IN jack** from the slot and remove the **system board** left-upward with the left side up.

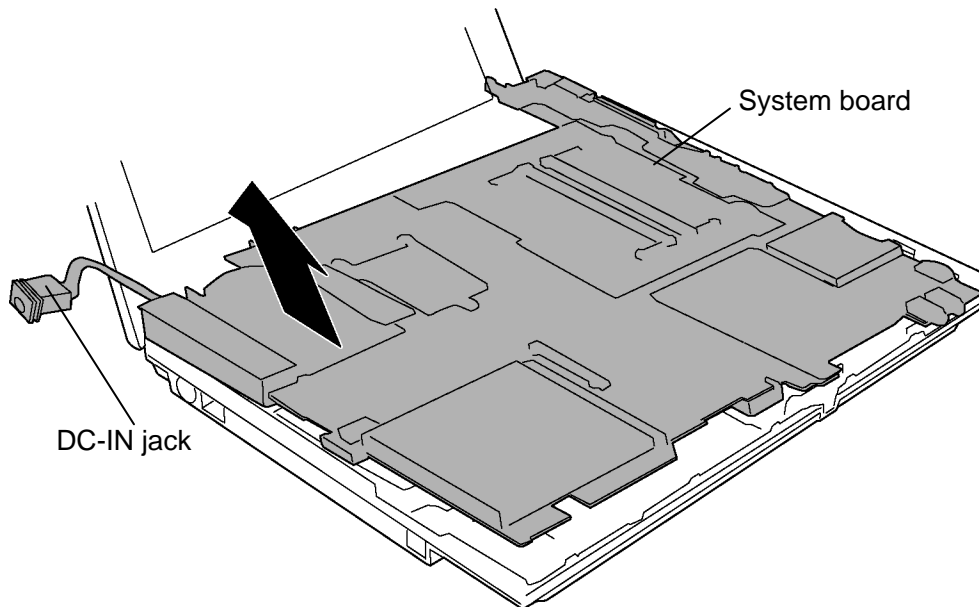

Figure 4-27 Removing the System board / DC-IN jack (2)

4. Disconnect the **DC-IN jack cable** from the connector **CN8800** on the system board.

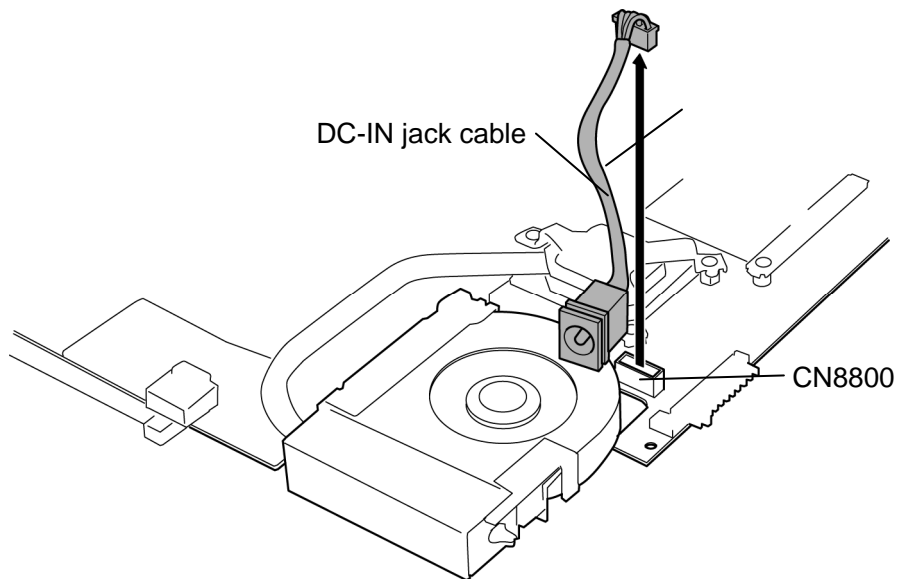

Figure 4-28 Removing the System board / DC-IN jack (3)

Installing the System board / DC-IN jack

To install the System board / DC-IN jack, follow the steps below and refer to Figure 4-26 to 4-28.

1. Connect the **DC-IN jack cable** to the connector **CN8800** on the system board.
2. Insert the right side connectors of the system board into the slots of the base assembly and install the **system board**.
3. Insert the **DC-IN jack** in to the slot of base assembly.
4. Connect the **speaker cable** to the connector **CN6170** on the system board.
5. Stick two **glass tapes** on the wireless LAN cable and speaker cable.

4.20 Modem jack / Wireless communication SW

To remove the Modem jack / Wireless communication SW, follow the steps below and refer to Figure 4-29 to 4-30.

1. Remove the following **screw** and the **Modem jack holder**.
 - M2.5×4B FLAT HEAD screw ×1
2. Remove the **Modem jack** stuck to the base assembly with a double sided tape from the slot.
3. Open the **insulator** and remove the **Modem jack cable** from the slot of the base assembly.

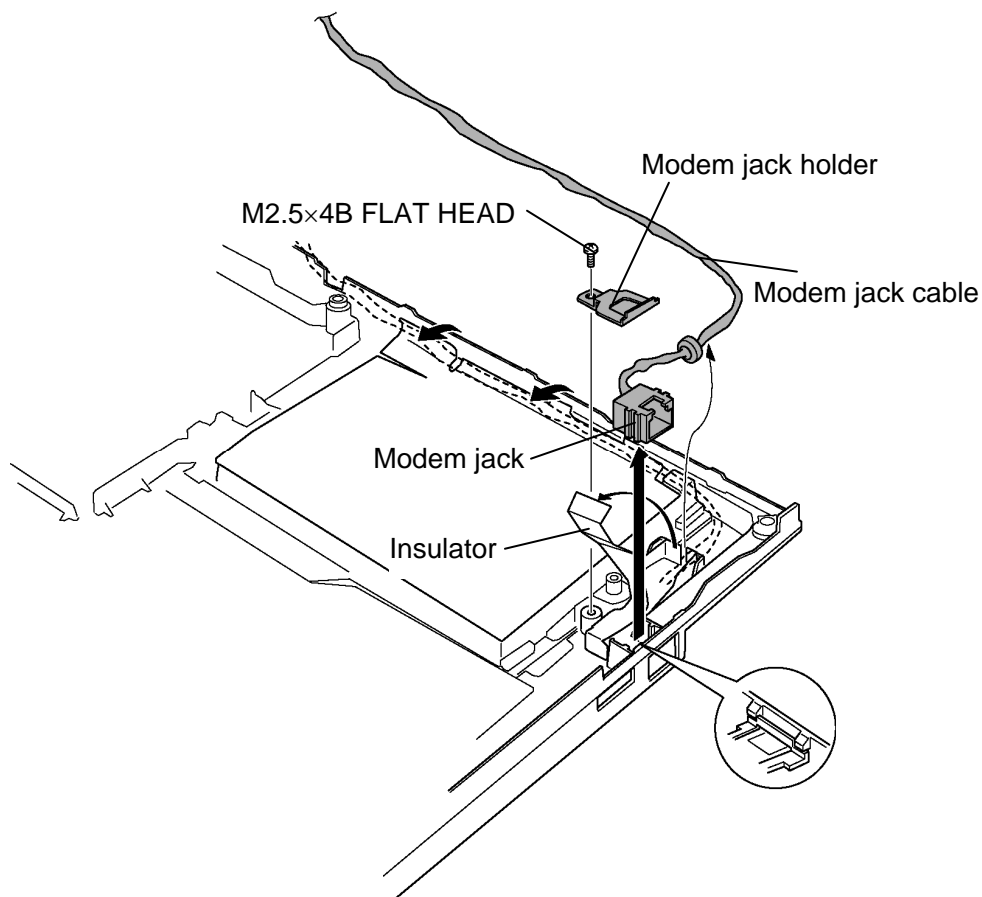

Figure 4-29 Removing the Modem jack

4. Push the **wireless communication SW** from the inside of the base assembly to remove.

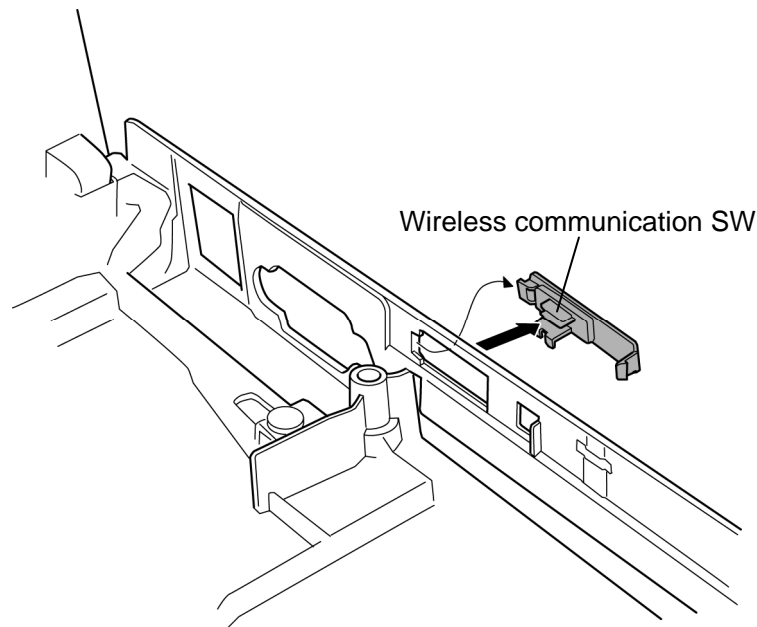

Figure 4-30 Removing the wireless communication SW

Installing the Modem jack / Wireless communication SW

To install the Modem jack / Wireless communication SW, follow the steps below and refer to Figure 4-29 and 4-30.

1. Insert the **wireless communication SW** into the hole of the base assembly from the outside.
2. Install the **Modem jack** into the slot of the base assembly and pass the **Modem jack cable** into the slot and close the **insulator**.

3. Install the **Modem jack holder** and secure it with the following screw.

- M2.5×4B FLAT HEAD screw ×1

CAUTION: When installing the Modem jack holder, insert the tip of the modem jack holder under the hook of the base assembly.

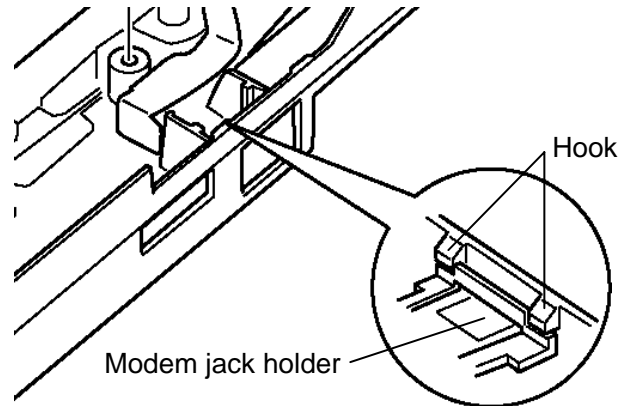

CAUTION: When installing the wireless communication SW, make sure the switch of the wireless communication SW works properly.

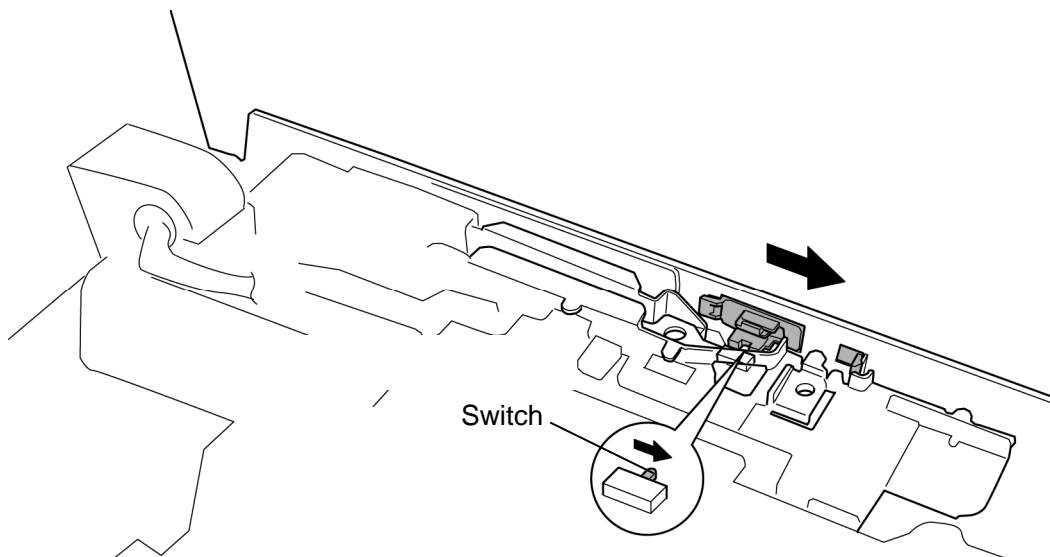

4.21 Fan/CPU

Removing the Fan/CPU

To remove the fan/CPU, follow the steps below and refer to Figure 4-31 to 4-33.

CAUTION: 1) The CPU can become very hot during operation. Be sure to let it cool before starting repair work.
2) When you remove the heat sink, wipe the grease off of the bottom of the heat sink and top of the CPU. Apply new grease when installing.

1. Remove the **glass tape** on the back of the system board and disconnect the **fan cable** from the connector **CN8771** on the system board.
2. Remove the following **screws** securing the CPU holder in the opposite order of the marks (number) on the holder and remove the **CPU holder**.
 - M2×4B BIND screw ×3

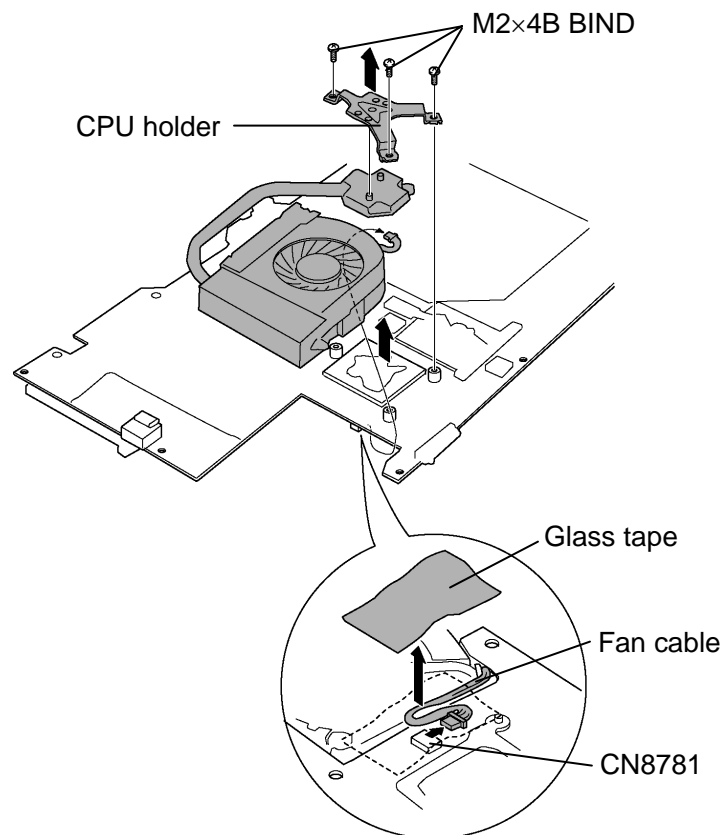

Figure 4-31 Removing the CPU holder

3. Remove the following **screws and fan**.

- M2.5×4B FLAT HEAD screw ×2

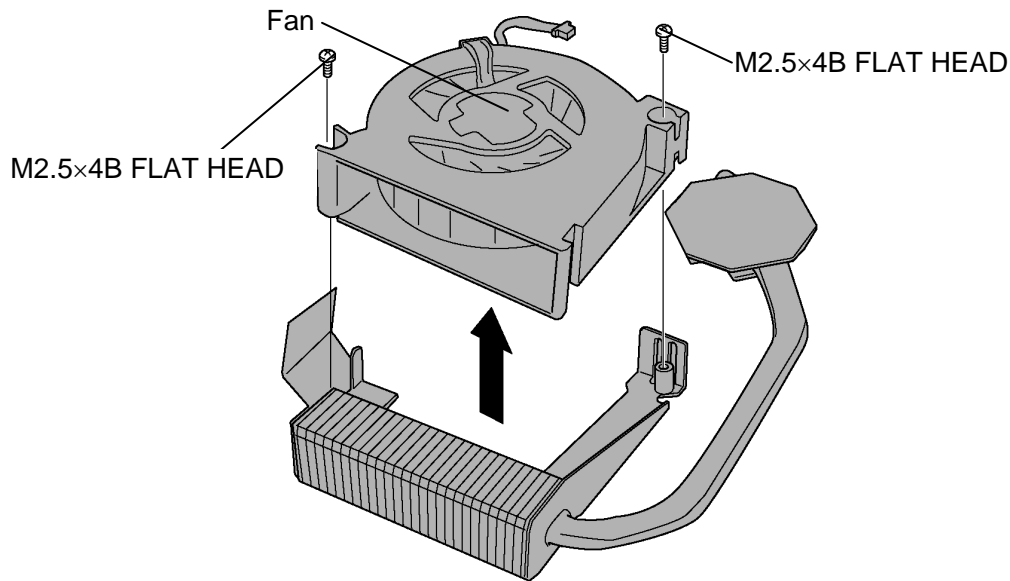

Figure4-32 Removing the fan

4. Unlock the **CPU** by turning the **cam** counterclockwise on the CPU socket by 90 degrees with a flat-blade screwdriver.

Figure 4-33 Removing the CPU

5. Remove the **CPU**.

CAUTION: When removing the CPU, lift it up right above. Otherwise, pins of CPU may be damaged.

Installing the Fan/CPU

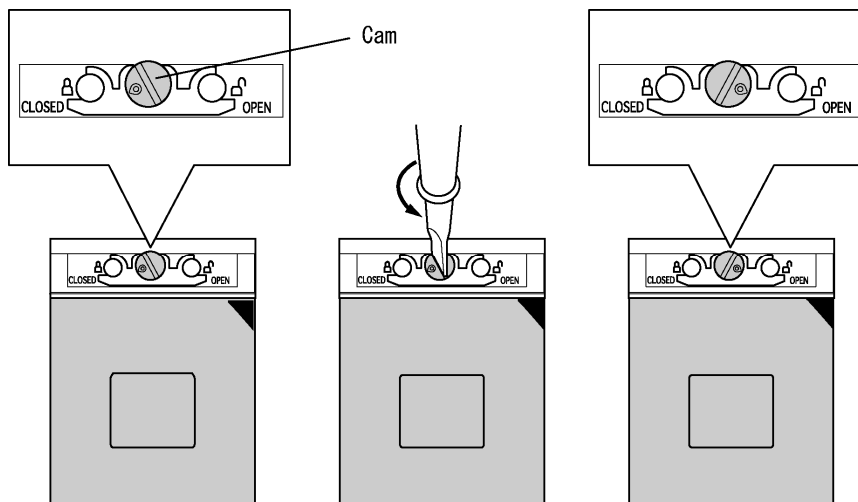
To install the fan/CPU, follow the steps below and refer to Figure 4-31 to 4-35.

1. Make sure the **cam** is in the open position.
2. Seat the **CPU** in the CPU socket. Make sure the direction and position of CPU is correct to avoid damaging pins on the CPU.

CAUTION: Place the CPU in such direction as shown below. (Pay attention to the position of the triangle mark on the CPU.)

3. Fix the **CPU** by turning the **cam** on the CPU socket by 90 degrees clockwise with a flat-blade screwdriver (in the order shown in the figure below).

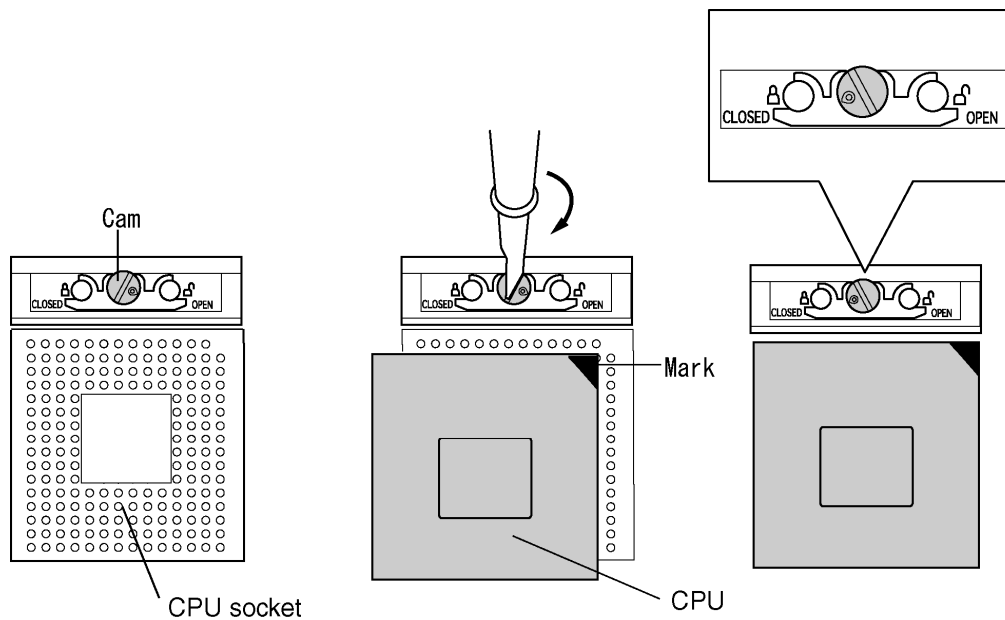

Figure 4-34 Installing the CPU

4. Apply new **grease** on the CPU using a special syringe as shown in the following figure. Apply quarter of scale (0.25ml) of grease evenly on the CPU chip. When silicon grease is already applied to the CPU, wipe them off with a close in advance.

CAUTION: *When installing the CPU, apply new grease on the top of the CPU chip. When installing the fin, make sure the bottom of the fin covers the top of the CPU.*

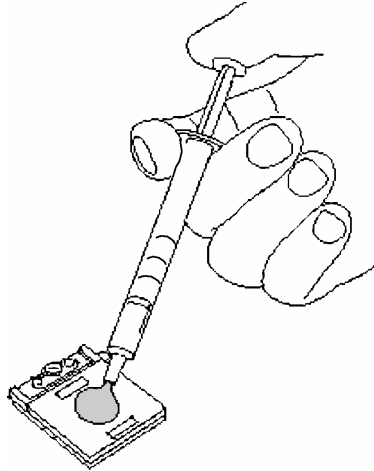

Figure 4-35 Applying new grease

5. Install the **CPU heat sink**.
6. Place the **CPU holder** and secure it with the following **screws** in the order of the number marked on the holder.
 - M2×4B BIND screw ×3

CAUTION: *Tighten the screws in the order of mark “1”, “2” and “3” on the CPU holder.*

7. Place the **fan** and secure it with the following **screws**.
 - M2.5×4B FLAT HEAD screw ×2
8. Connect the **fan cable** to the connector **CN8781** and stick the **glass tape**.

4.22 HDD cable/PC card slot

Removing the HDD cable/PC card slot

To remove the HDD cable/PC card slot, follow the steps below and refer to Figure 4-36 and 4-37.

1. Lift up the **HDD cable** from the slot of the HDD cable holder and remove the following screw.
 - M2×4B BIND screw ×1
2. Remove **HDD cable** from the connector **CN1850** on the system board.
3. Remove the **HDD cable holder**.

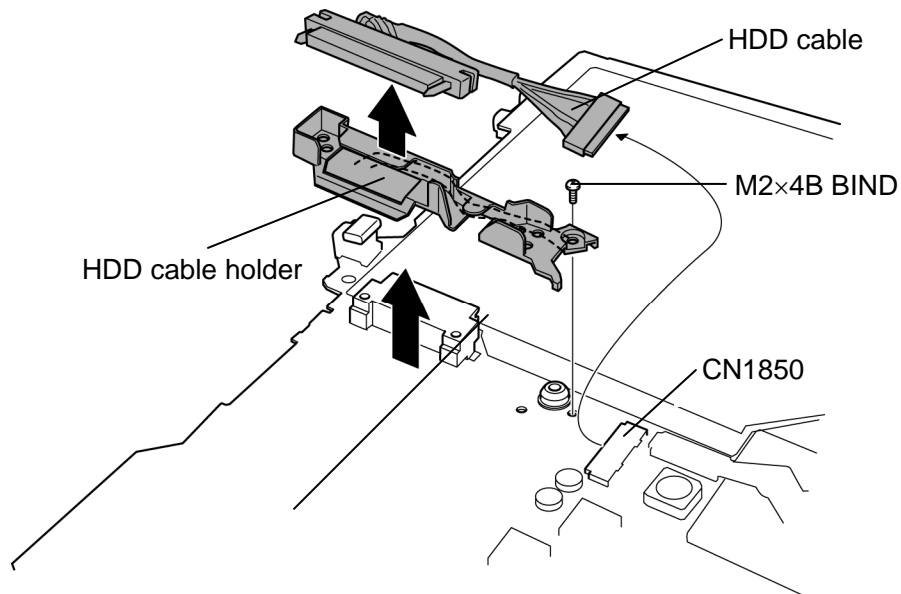

Figure 4-36 Removing the HDD cable

4. Peel the **insulator** and remove the following **screws** (on the back of the system board).
 - M2×3S S-THIN HEAD screw ×2
5. Open two **latches** outward and remove the **PC card slot** from the system board.

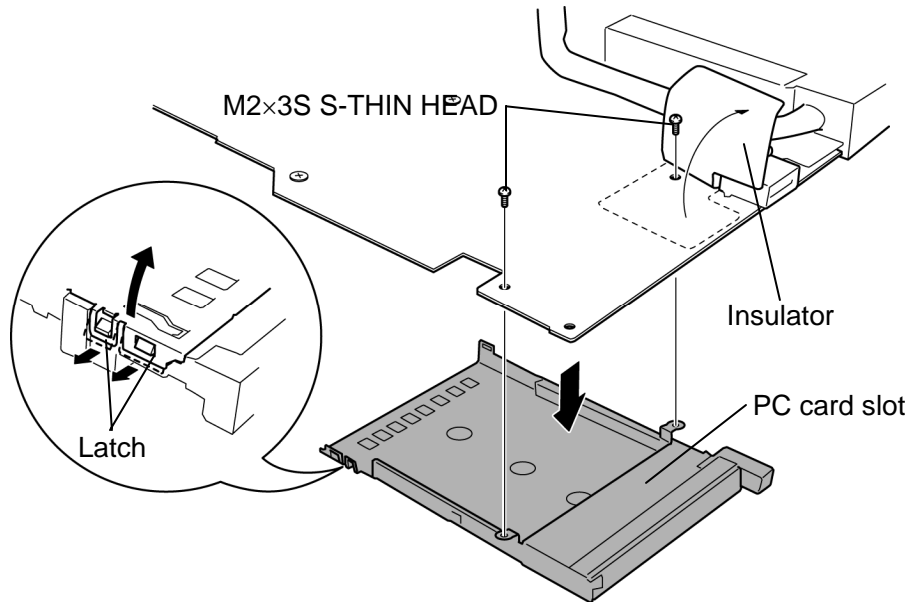

Figure 4-37 Removing the PC card slot

Installing the HDD cable/PC card slot

To install the HDD cable/PC card slot, follow the steps below and refer to Figure 4-36 and 4-37.

1. Install the **PC card slot** and secure it with the following **screws**.
 - M2×3S S-THIN HEAD screw ×2
2. Connect the **HDD cable** to the connector **CN1850** on the back of the system board.
3. Install the **HDD cable holder** on the system board and secure it with the following **screw**.
 - M2×4B BIND screw ×1
4. Arrange the HDD cable on the HDD cable holder in place.

4.23 LCD unit/FL inverter

Removing the LCD unit/FL inverter

To remove the LCD unit/FL inverter, follow the steps below and refer to Figure 4-38 to 4-42.

1. Remove the following **screws** and lift up the **display assembly** right above to separate it and base assembly.
 - M2.5×4B FLAT HEAD screw ×3

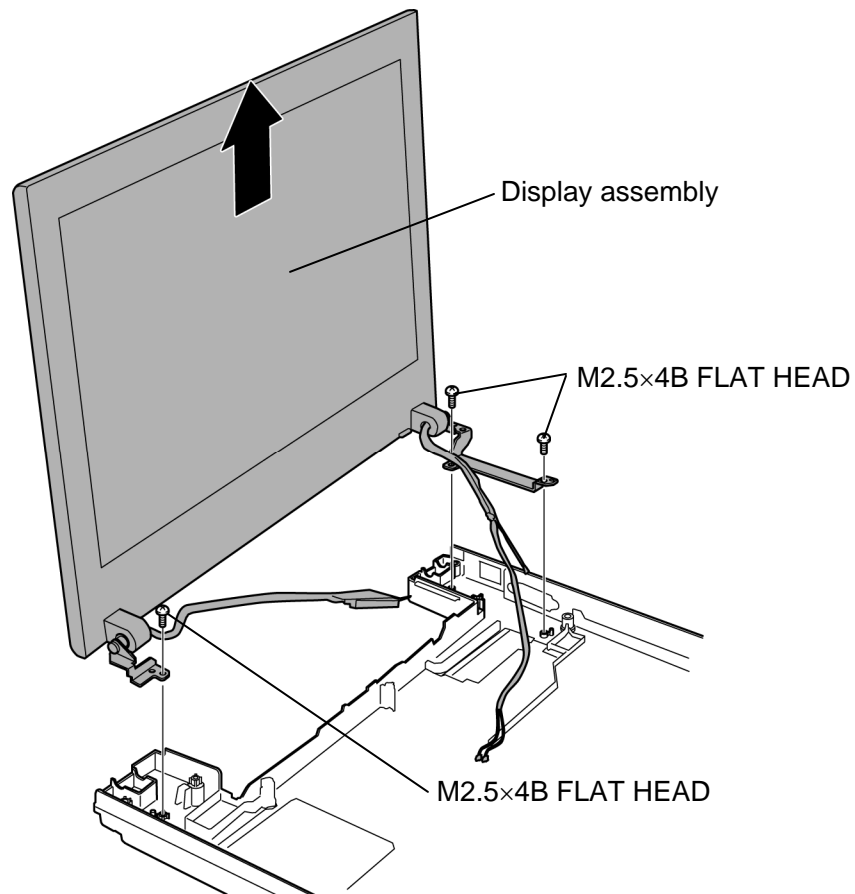

Figure 4-38 Removing the display assembly

2. Remove the **mask seals** (2 points), **mask rubbers** (2 points) and following **screws** securing the LCD mask.
 - M2.5×6B FLAT HEAD screw ×4
3. Remove the **LCD mask** (stuck with a double-sided tape) while releasing the latches.

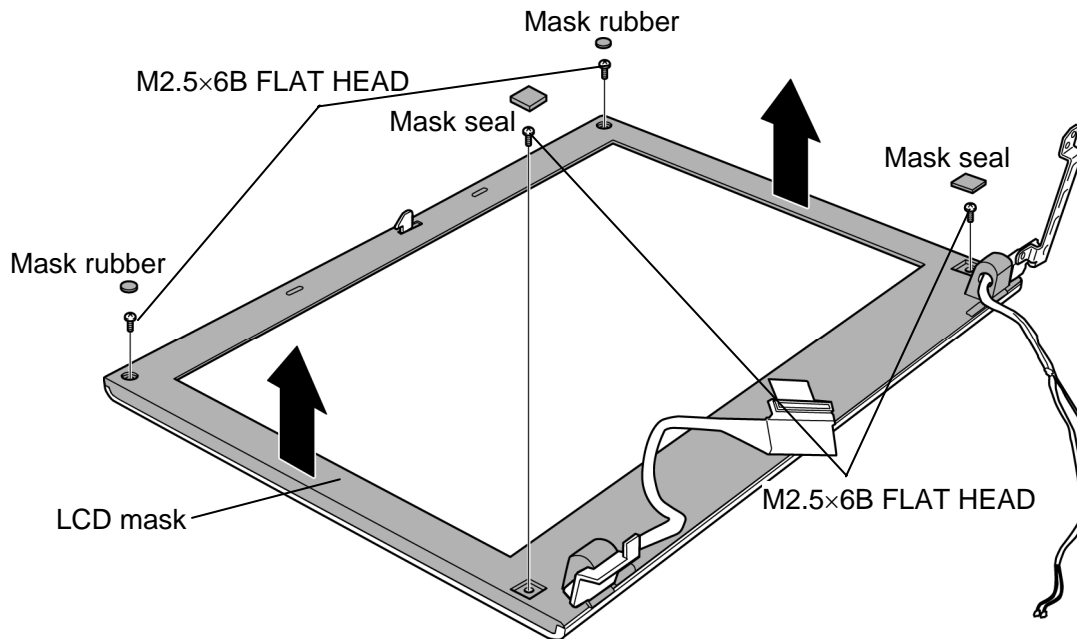
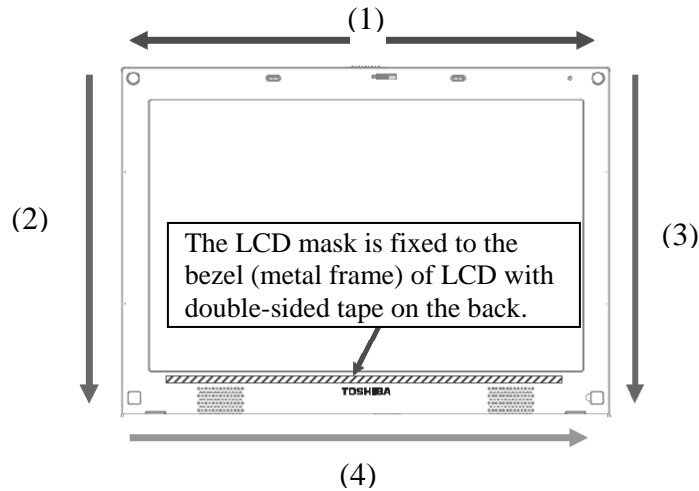

Figure 4-39 Removing the LCD mask

CAUTION: When releasing the latches, be sure to keep the following steps (order) referring to the figure on next page.

1. Release the latches from the center toward the outside. ((1))
2. Release the latches from the top toward the bottom. ((2), (3) or (3), (2))
3. Release the latches on the bottom from the left toward the right. ((4))

CAUTION: (continued)



As shown in the figure, the bottom side of the LCD mask is fixed to the LCD bezel with double-sided tape. If the LCD mask is pulled toward you in removing it, the bezel may be deformed. When removing the bottom side, be sure to remove it carefully while removing the double-side tape slowly. When the bezel of LCD deformed, replace the LCD unit with new one. When the LCD mask deformed, replace the display mask with new one.

4. Pull out the **insulator** under the LCD.
5. Remove the **FL inverter** while peeling off the double-sided tape.
6. Disconnect the **cables** from the FL inverter.

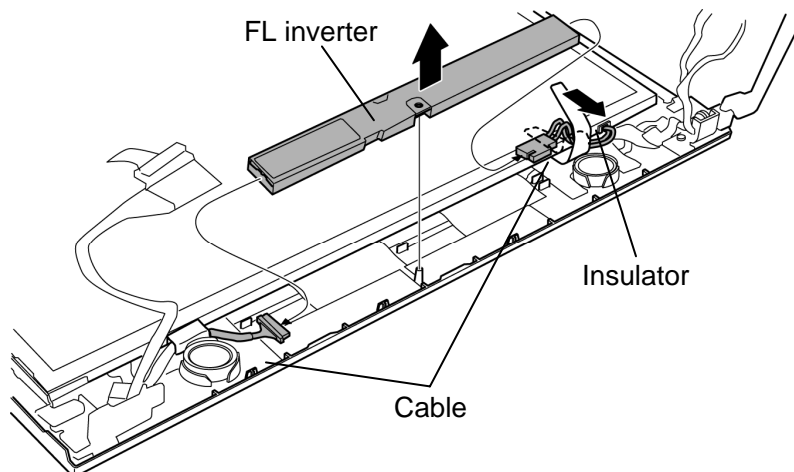

Figure 4-40 Removing the FL inverter

- Carefully lift up the top of the **LCD unit**.

NOTE: When lifting up the top of the LCD unit, hold the corners of the LCD unit. The top edge of LCD unit is sensitive area.

- Remove two **glass tapes** securing the LCD cable.
- Disconnect the **LCD cable** from the connector on the LCD unit and remove the **LCD unit**.

CAUTION: When removing the LCD cable, be careful not to damage the connector.

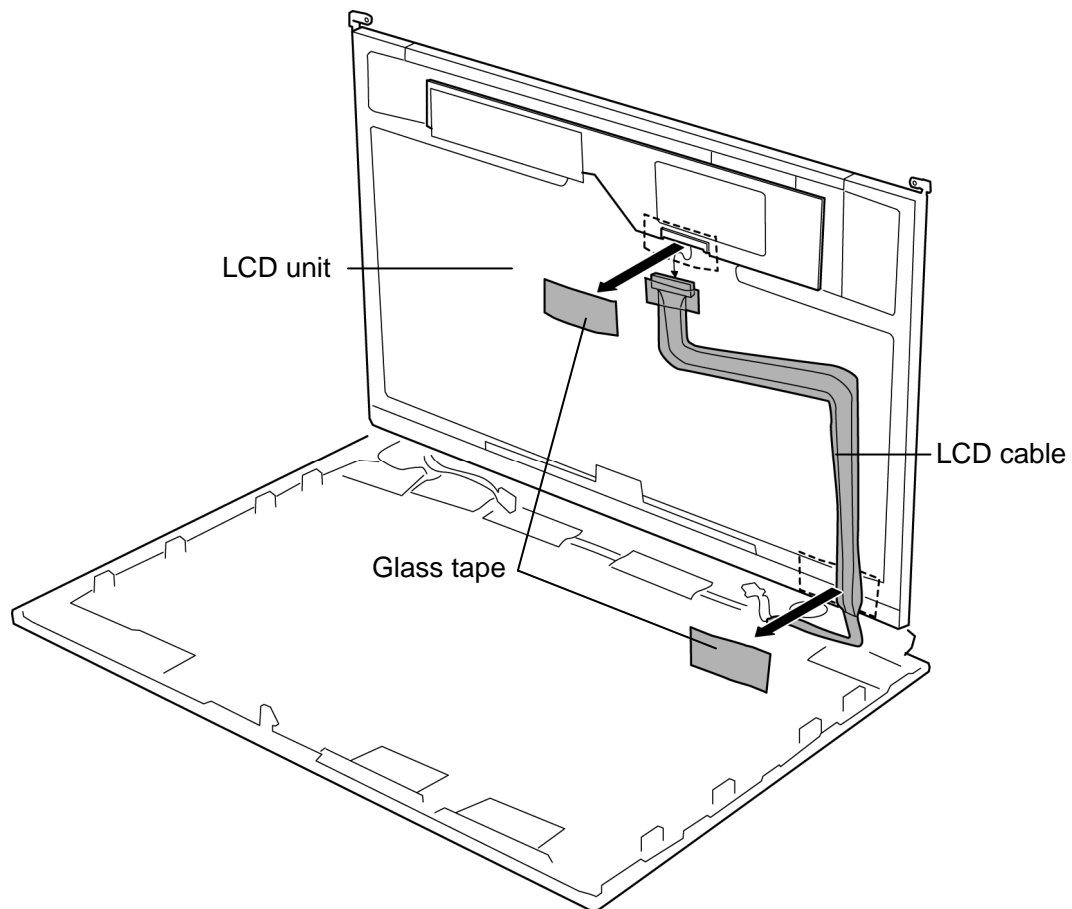

Figure 4-41 Removing the LCD unit

9. Remove the following **screws** and two **LCD supports** from the LCD.

- M2×3S S-THIN HEAD screw ×4

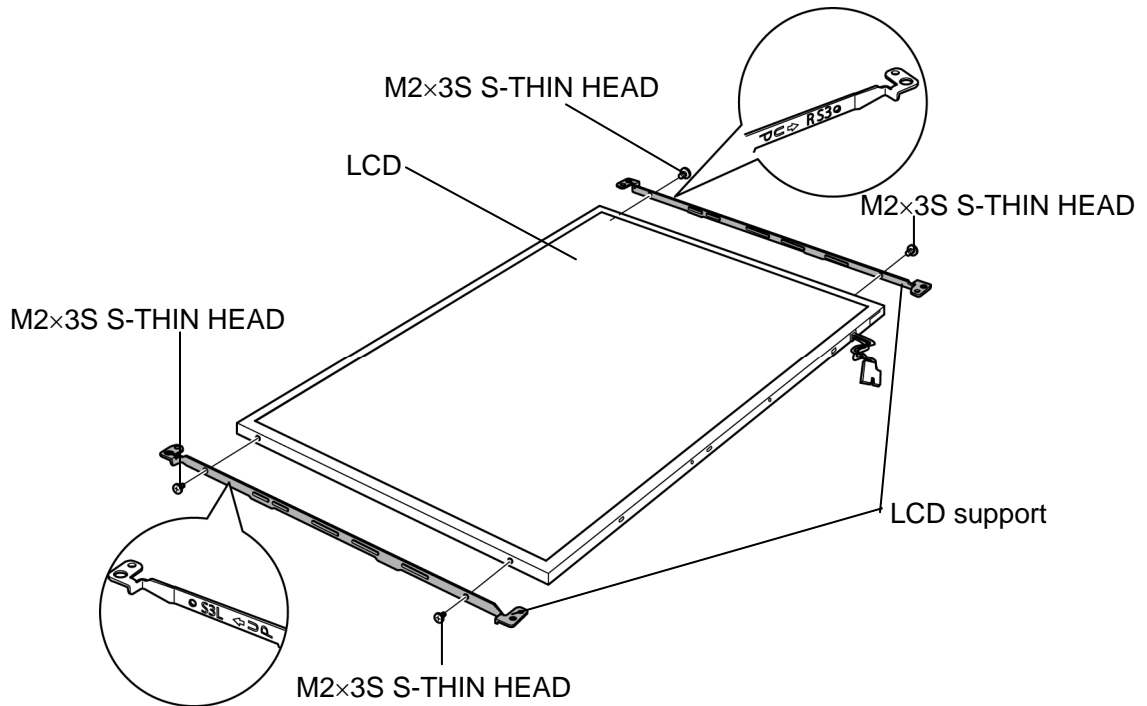

Figure 4-42 Removing the LCD support

NOTE: 1) Be careful not to apply pressure to the ICs along the edge of LCD unit. The ICs are easily damaged.

2) For environmental reasons, do not throw away a malfunctioning LCD unit (or FL). Please follow local ordinances or regulations for its disposal.

Installing the LCD unit / FL inverter

To install the LCD unit / FL inverter, follow the steps below and refer to Figure 4-38 to 4-42.

1. Set two **LCD supports** to the LCD and secure them with the following **screws**.

- M2×3S S-THIN HEAD screw ×4

CAUTION: When installing the LCD support, do not mistake the left for the right and vice versa. “L” for the left, “R” for the right and “UP” for the up of the bracket are marked on the bracket.

2. Stand the LCD unit on the display cover and connect the **LCD cable** to the connector on the back of the LCD unit. Stick two **glass tapes** on the connector of the LCD.
3. Install the **LCD unit** to the display cover.
4. Connect two **cables** to the FL inverter.
5. Install the **FL inverter** in place while sticking the double-sided tape.
6. Insert the **insulator** under the LCD unit.
7. Install the **LCD mask** (with double-sided tape) while hooking the latches.
8. Secure the LCD mask with the following **screws**.
 - M2.5×6B FLAT HEAD screw ×4
9. Stick the **mask seals** (2 points) and **mask rubbers** (2 points).
10. Install the **display assembly** to the base assembly and secure it with the following **screws**.
 - M2.5×4B FLAT HEAD screw ×3

4.24 Speaker/LCD cable

Removing the Speaker/LCD cable

To remove the speaker/LCD cable, follow the steps below and refer to Figure 4-43 and 4-44.

1. Turn up two **insulators** and peel off two **glass tapes**.
2. Take out the **speakers** from the slot.

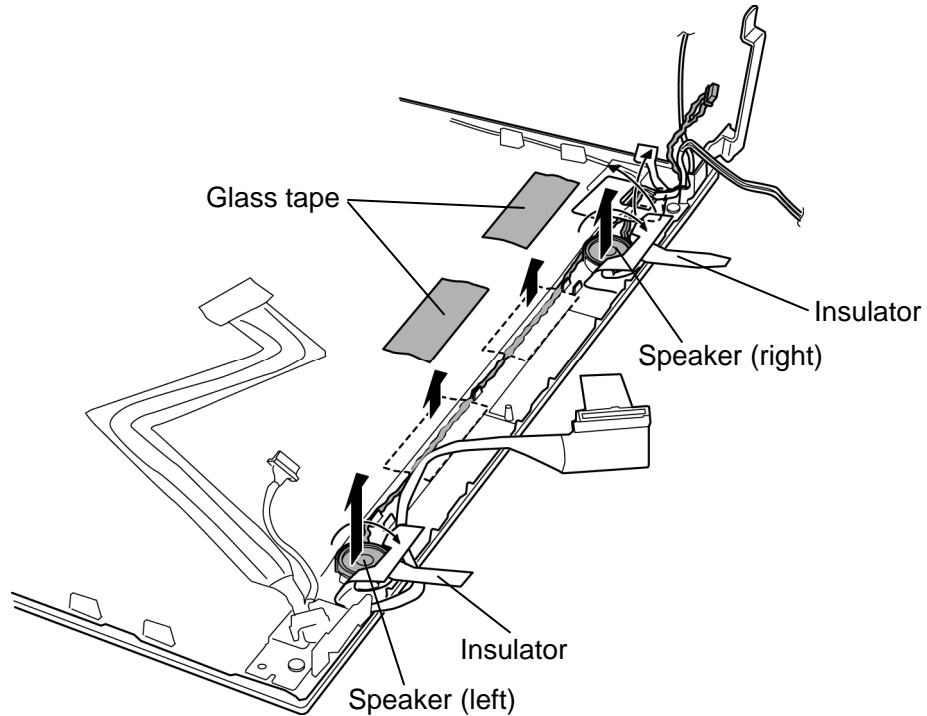

Figure 4-43 Removing the speaker

3. Remove the **LCD cable holder** while releasing hooks.
4. Take out the **LCD cable** from the slot.

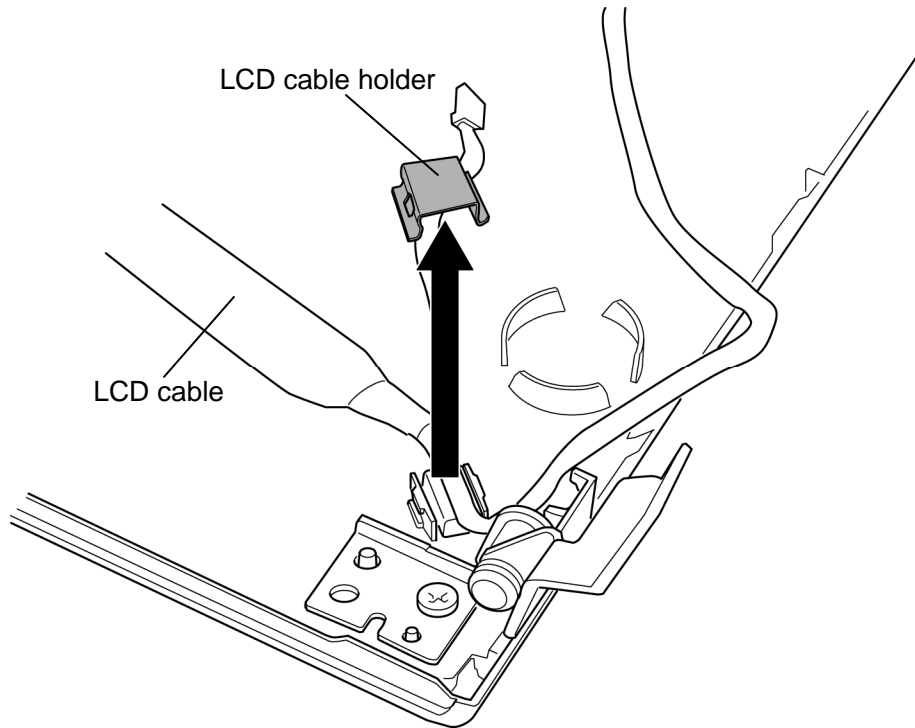

Figure 4-44 Removing the LCD cable

Installing the Speaker/LCD cable

To install the speaker/LCD cable, follow the steps below and refer to Figure 4-43 and 4-44.

1. Seat the **LCD cable** to the slot and install the **LCD cable holder**.
2. Install the **speakers** into the slots.
3. Arrange the **speaker cables** in place and secure it with two **insulators** and two **glass tapes**.

4.25 Cover latch

Removing the Cover latch

To remove the cover latch, follow the steps below and refer to Figure 4-45.

1. Remove the **cover cap** while pushing **three latches** from the LCD cover latch side.
2. Remove the **LCD cover latch**. Be careful not lose the **spring**.

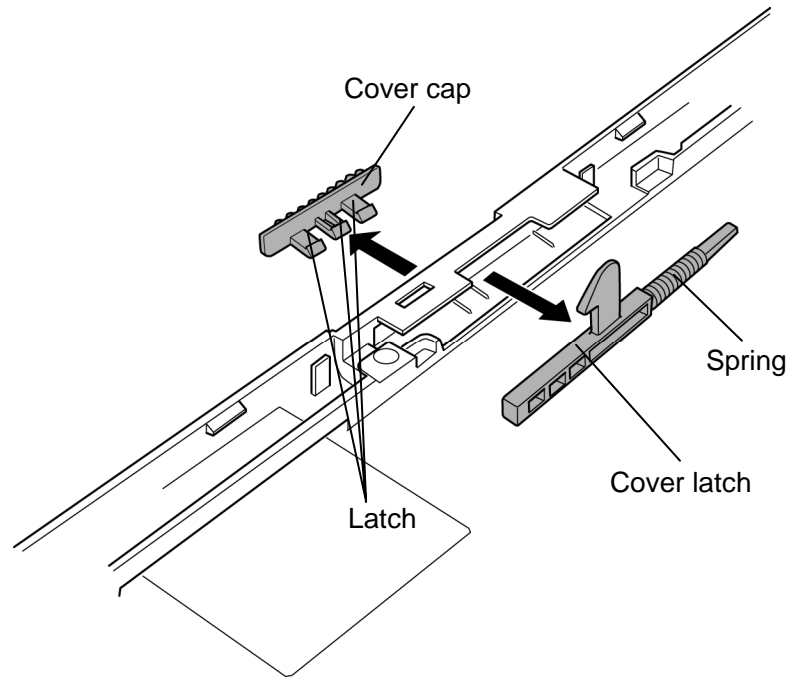

Figure 4-45 Removing the cover latch

Installing the Cover latch

To install the cover latch, follow the steps below and refer to Figure 4-45.

1. Install the **cover latch** in place. Be careful not lose the **spring**.
2. Set the **cover cap** and push it until the latches are engaged.

4.26 Wireless LAN antenna/Bluetooth antenna

Removing the Wireless LAN antenna/Bluetooth antenna

To remove the wireless LAN antenna/Bluetooth antenna, follow the steps below and refer to Figure 4-46.

1. Peel off five **glass tapes** securing the wireless LAN antenna cables and Bluetooth antenna cable.
2. Remove the **wireless LAN antennas** and **Bluetooth antenna** from the slot of the display assembly.

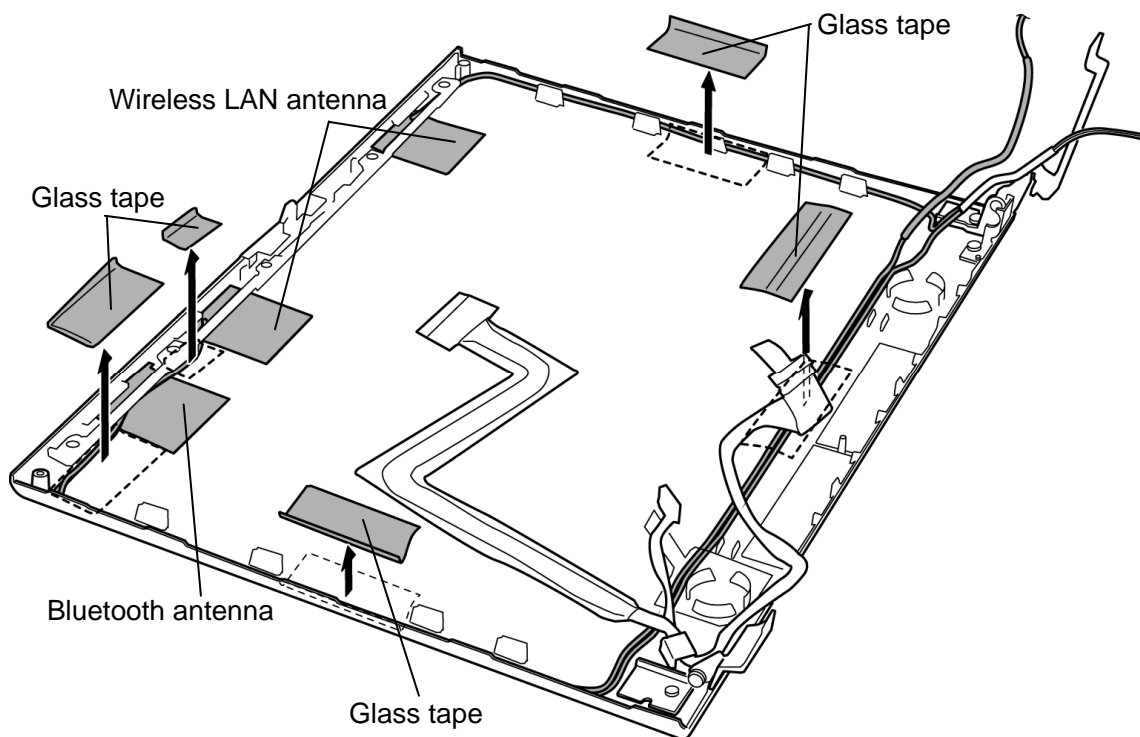

Figure 4-46 Removing the wireless LAN antenna/Bluetooth antenna

Installing the Wireless LAN antenna/Bluetooth antenna

To install the wireless LAN antenna/Bluetooth antenna, follow the steps below and refer to Figure 4-46.

1. Install the **wireless LAN antennas** and **Bluetooth antenna** on the display assembly in place.
2. Stick five **glass tapes** to secure the wireless LAN antenna cables and Bluetooth antenna cable.

4.27 Hinge

Removing the Hinge

To remove the hinge, follow the steps below and refer to Figure 4-47.

1. Remove the following **screws, washers and hinges** on the both sides.

- M2.5×5B FLAT HEAD screw ×2
- M2.5 Washer ×2

2. Remove the following **screws and hinge caps** on the both sides.

- M2.5×4B FLAT HEAD screw ×2

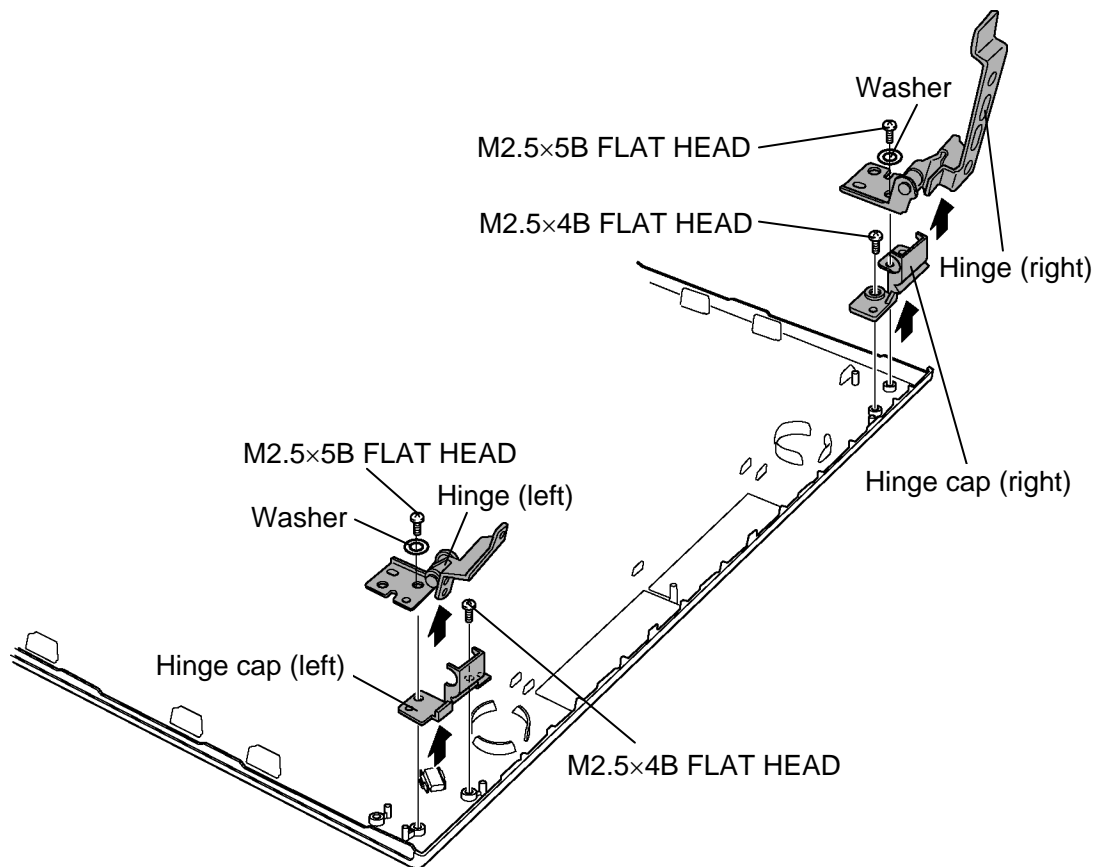

Figure 4-47 Removing the hinge

Installing the Hinge

To install the hinge, follow the steps below and refer to Figure 4-47.

1. Install the **hinge caps** (left and right) and secure them with the following **screws**.
 - M2.5×4B FLAT HEAD screw ×2
2. Install the **hinge** (left and right) and secure them with the **washers** and following **screws**.
 - M2.5×5B FLAT HEAD screw ×2
 - M2.5 Washer ×2

4.28 Battery slider

Removing the Battery slider

To remove the battery slider, follow the steps below and refer to Figure 4-48.

1. Release the latches of the battery sliders (left and right) and remove the **slider caps** from the bottom of the computer.
2. Take out the **battery sliders** from the base assembly.

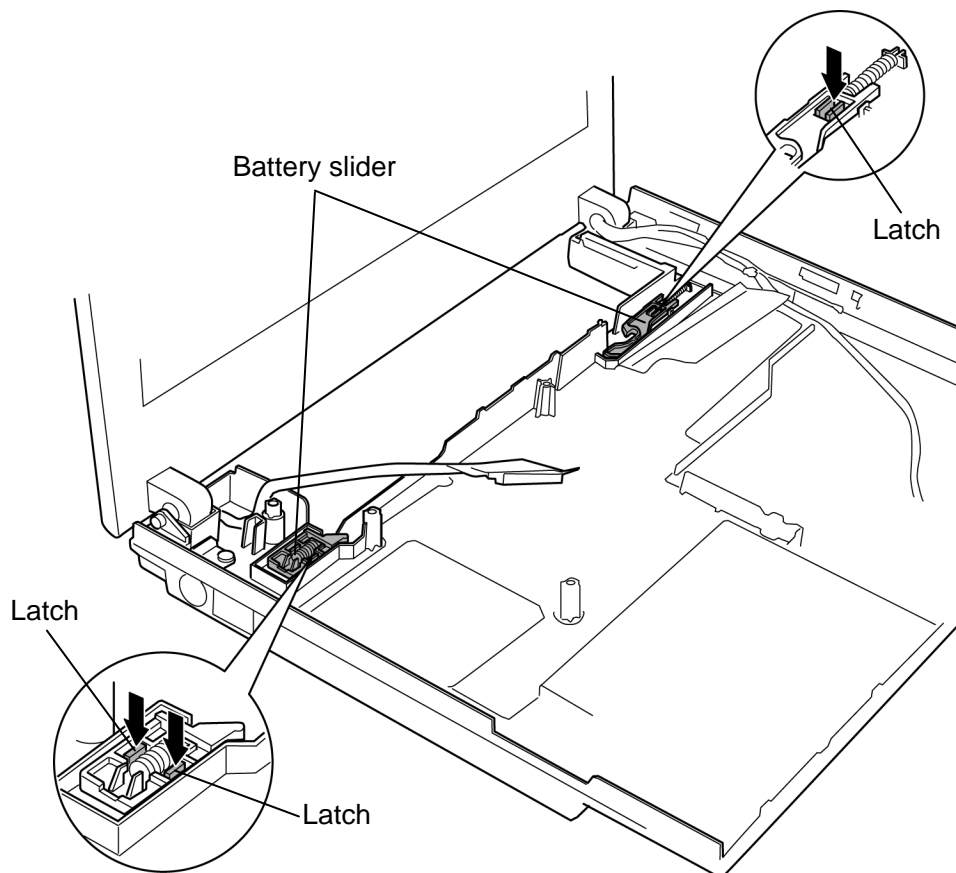

Figure 4-48 Removing the battery slider

Installing the Battery slider

To install the Battery slider, follow the steps below and refer to Figure 4-48.

1. Install the **springs** to the **battery sliders** and set them to the base assembly.
2. Install the **slider caps** to the base assembly from the bottom of the computer.

4.29 Fluorescent Lamp

This system uses LCD modules from the following suppliers. The procedure for replacing the fluorescent lamp is different for each LCD module. Refer to the appropriate procedure.

Type	Part No.	Supplier	Section
12.1-inch (SXGA+)	G33C0003C110	TMD	4.29.1
	G33C0003K110	SAMSUNG	4.29.2

- NOTE:**
- When working with a LCD module, always use a flat, grounded table.
 - Handle the backlight unit in the environment without dust, such as on the clean bench. Keep the worktable free from any screws or other material that may scratch the LCD surface.
 - Use an anti-static or protective sheet.
 - When replacing the FL unit, cover with a finger protector or similar to prevent soiling or scratching the LCD panel.
 - Be careful when handling the lamp. Excessive force may break the lamp.
 - Be careful not to soil or deform the lamp reflector.
 - Make sure that the power of the LCD module is turned off before connecting or disconnecting cables and connectors.

4.29.1 Replacing the 12.1-inch WXGA TMD Fluorescent Lamp

CAUTION: *When replacing the fluorescent lamp, wear finger covers or gloves to avoid contaminating or damaging the LCD panel. Be careful not to let dust or other foreign substance into the module.*

Disassembling the 12.1-inch WXGA TMD Fluorescent Lamp

To disassemble the 12.1-inch XGA TMD fluorescent lamp, follow the steps below and refer to Figure 4-49 to 4-58.

Peeling off the tapes and insulation sheets

1. Place it on a flat surface that is free of foreign objects.
Make sure no dirt on the face to protect the surface of the LCD module from damage.
Put a protection sheet (e.g. soft cloth) on the face.

2. Remove insulation sheet (with the tape on the insulation side attached).

CAUTION: 1. Be careful not to damage the TAB, PCB, B/L reflection sheet.
2. Do not remove the insulation sheet to reuse it.
3. Do not damage the TAB and PCB when removing the double-sided tape of the insulation sheet.

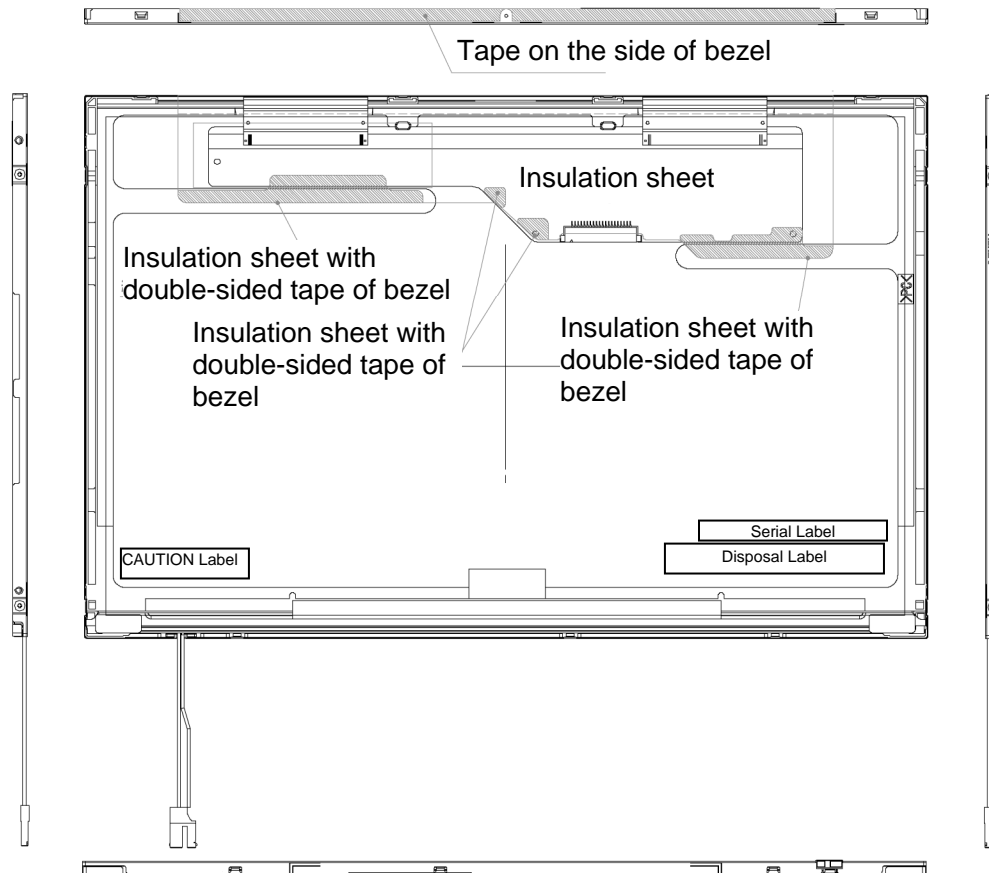

Figure 4-49 Replacing TMD fluorescent lamp (1)

Removing the screws

1. Remove the Insulation sheet from the side of Bezel.
2. Remove four screws on the right side and left side.

CAUTION: Be sure to use a Philips screwdriver with a point size 0 bit.

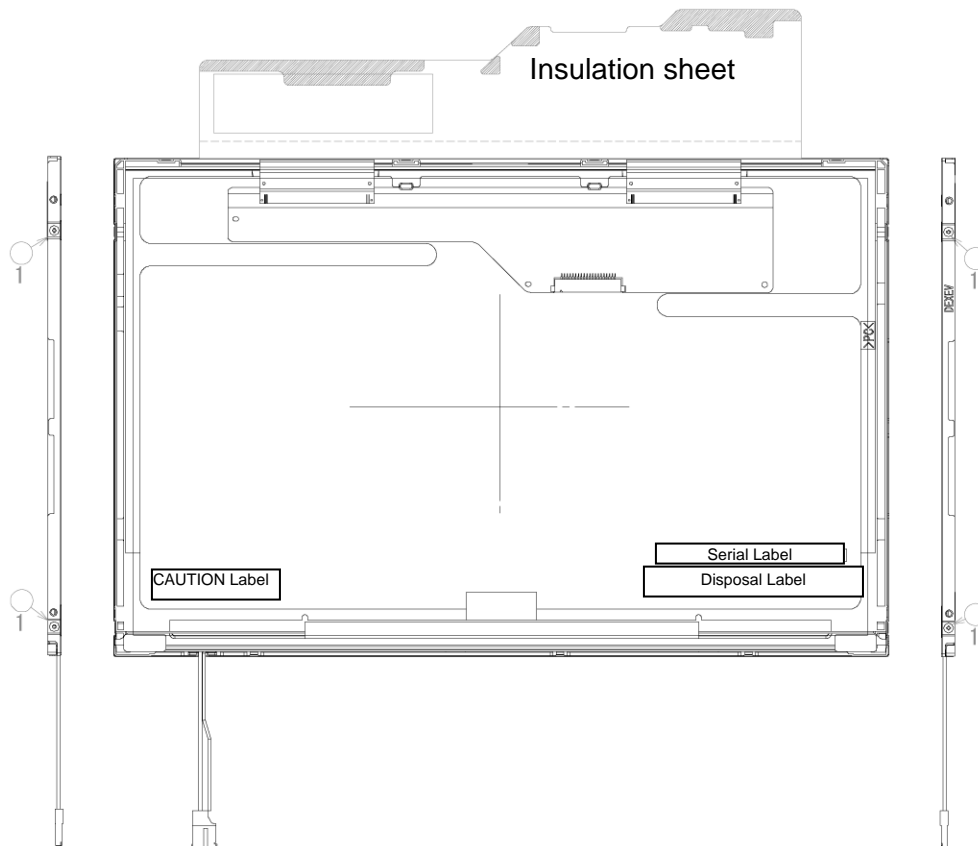

Figure 4-50 Replacing TMD fluorescent lamp (2)

Removing the bezel

1. Without removing the insulation tape, turn the face of module up.
2. Release the four latches of the bezel and frame (two positions on each side).
3. Release the three latches on the top to remove the bezel from the cell (The bezel is reused.). As the bezel and cell at the lower side are fixed with a double-sided tape, remove the bezel solely.

CAUTION: 1. When releasing the latches, do not damage the TAB and PCB.

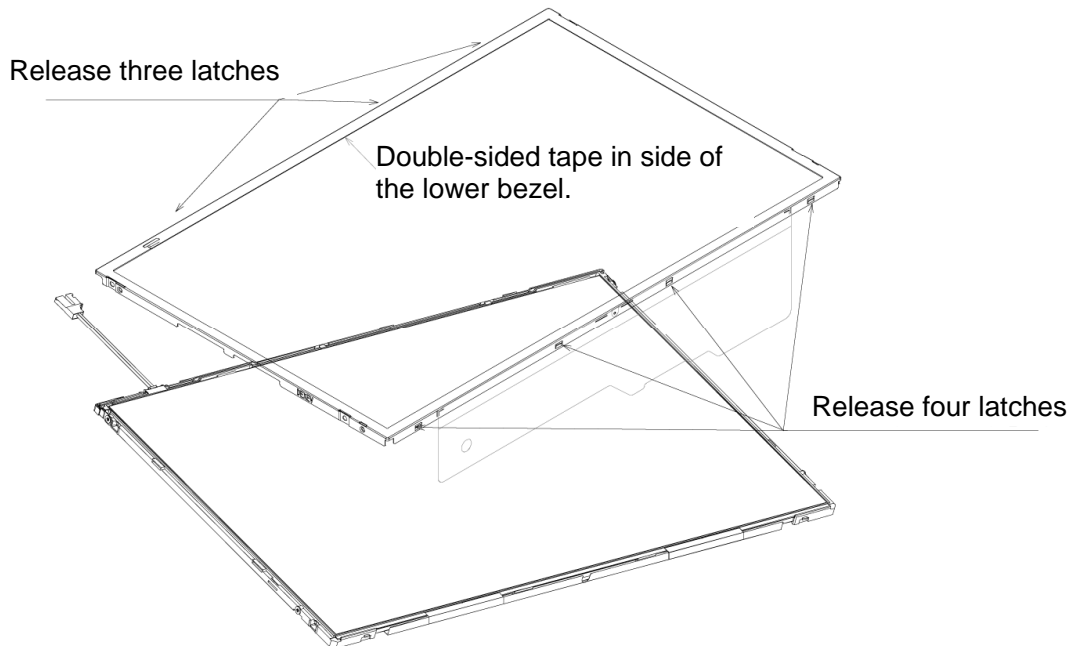

Figure 4-51 Replacing TMD fluorescent lamp (3)

Opening the PCB

1. Spread out the PCB horizontally.

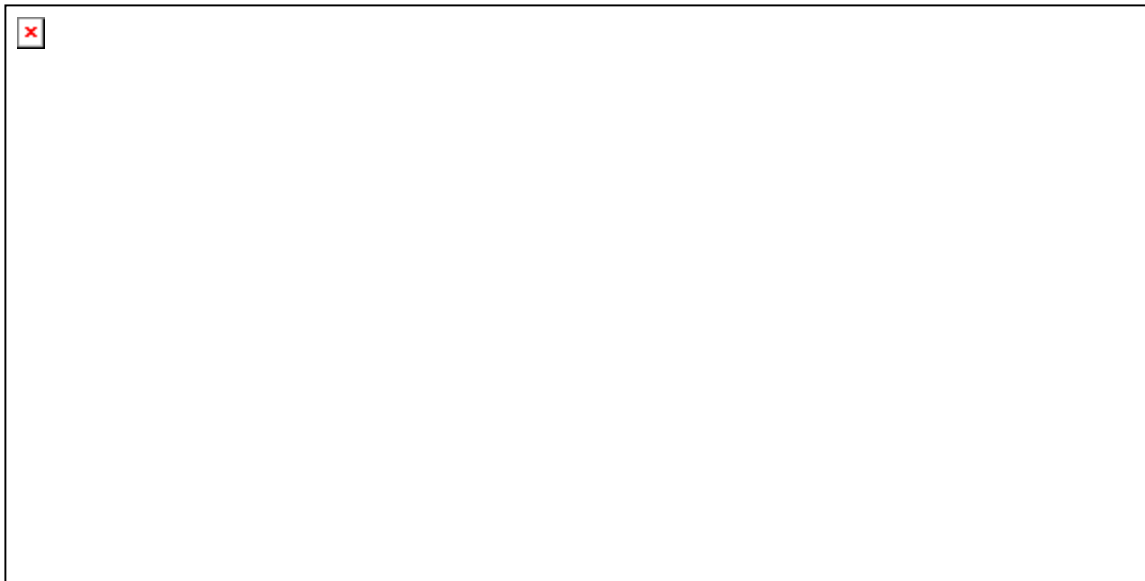
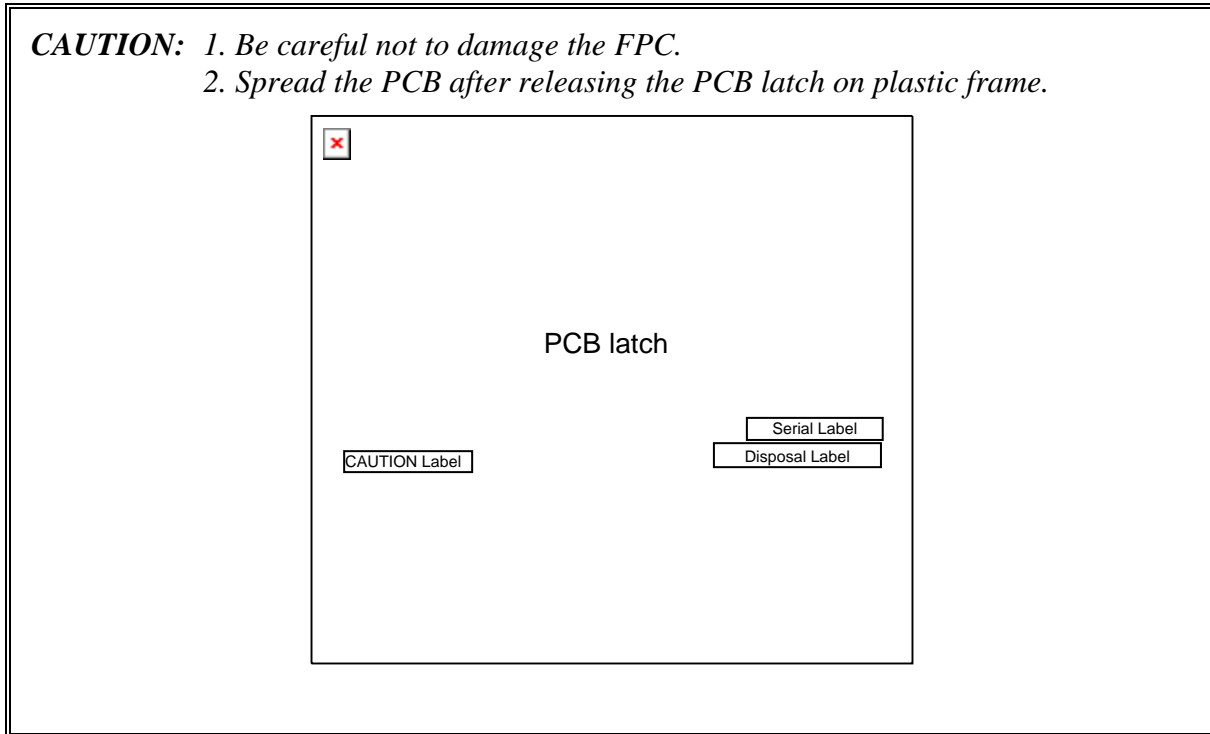

Figure 4-52 Replacing TMD fluorescent lamp (4)

Removing the cell with PCB

1. Remove the cell with PCB from the backlight unit as shown bellow.

CAUTION: 1. As the back light cell are fixed with a double-sided tape, remove the cell with PCB slowly not to break the cell.
2. Be careful not to damage the TAB.

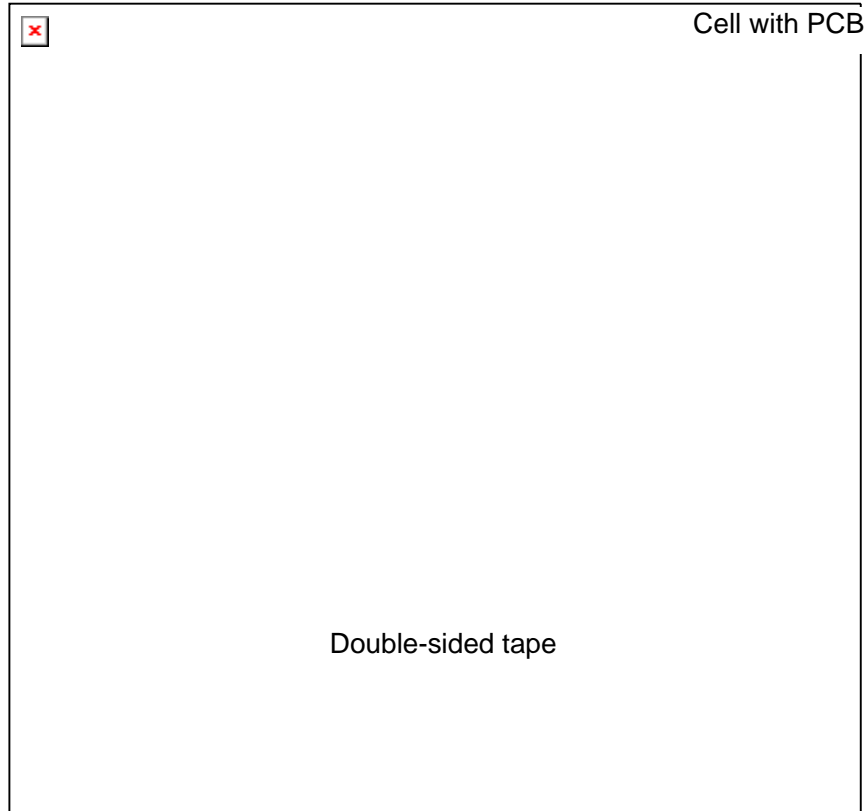

Figure 4-53 Replacing TMD fluorescent lamp (5)

Assembling Fluorescent lamp

Check of the backlight for replacement

1. Check the following items.

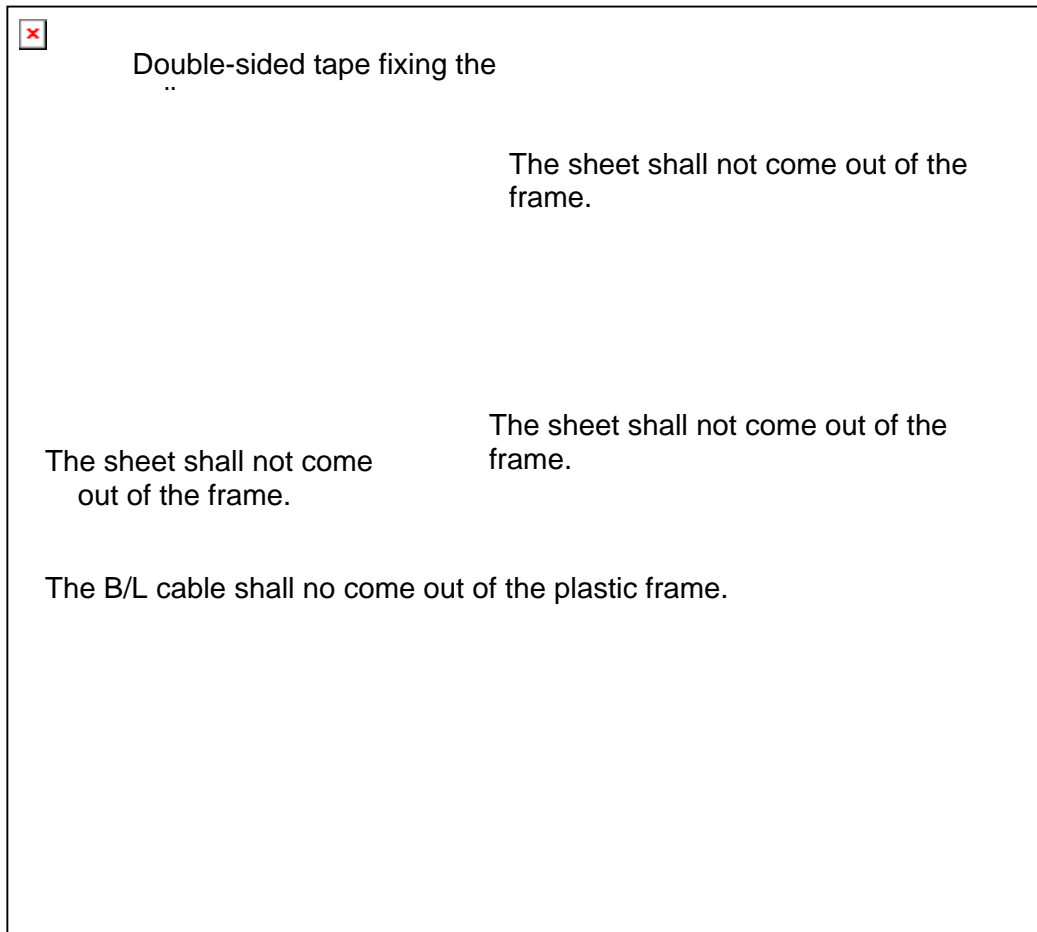

Figure 4-54 Replacing TMD fluorescent lamp (6)

Assembling the cell with PCB

1. Turn the backlight on.
2. Check that the backlight is free of dust, foreign objects, or damage. Perform this check also for the reverse side of the cell. Peel of the separation sheet of double-sided tape fixing the cell of the back light. Then install the cell with PCB in the backlight unit.

CAUTION: 1. Set the cell with PCB as far as it goes to the left upper of the backlight unit.
2. be careful not to damage the TAB.

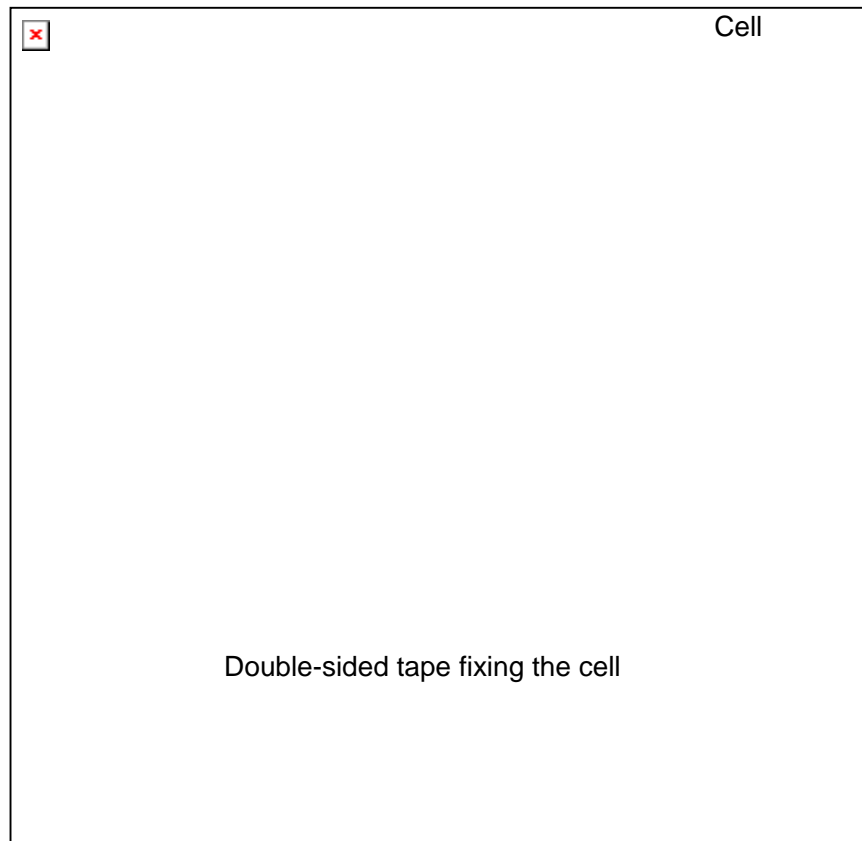

Figure 4-55 Replacing TMD fluorescent lamp (7)

Folding the TAB/PCB

1. Fold down the TAB (PCB) toward the reverse side of the backlight unit.

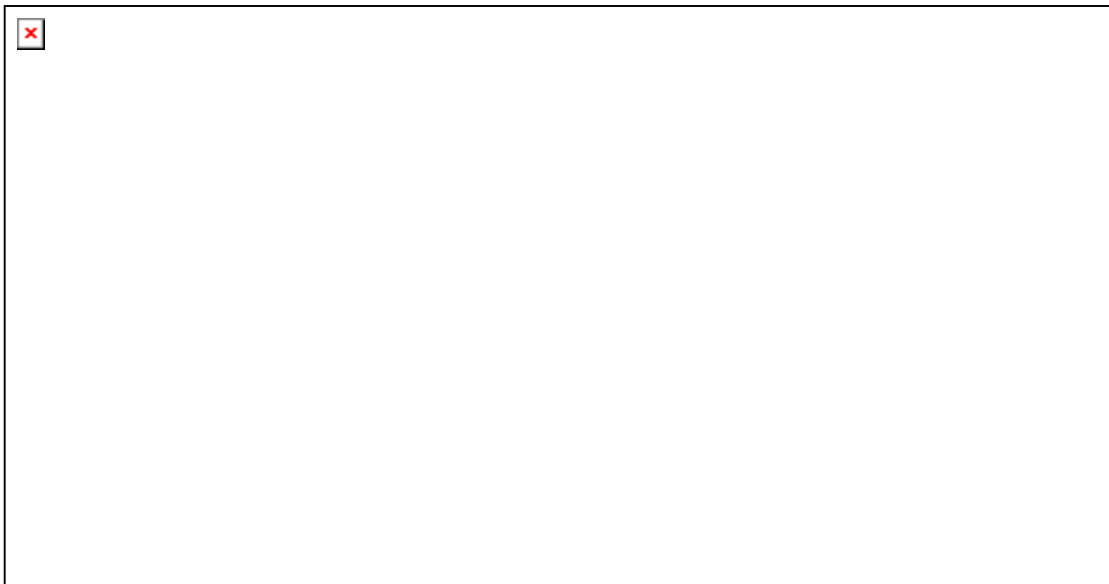
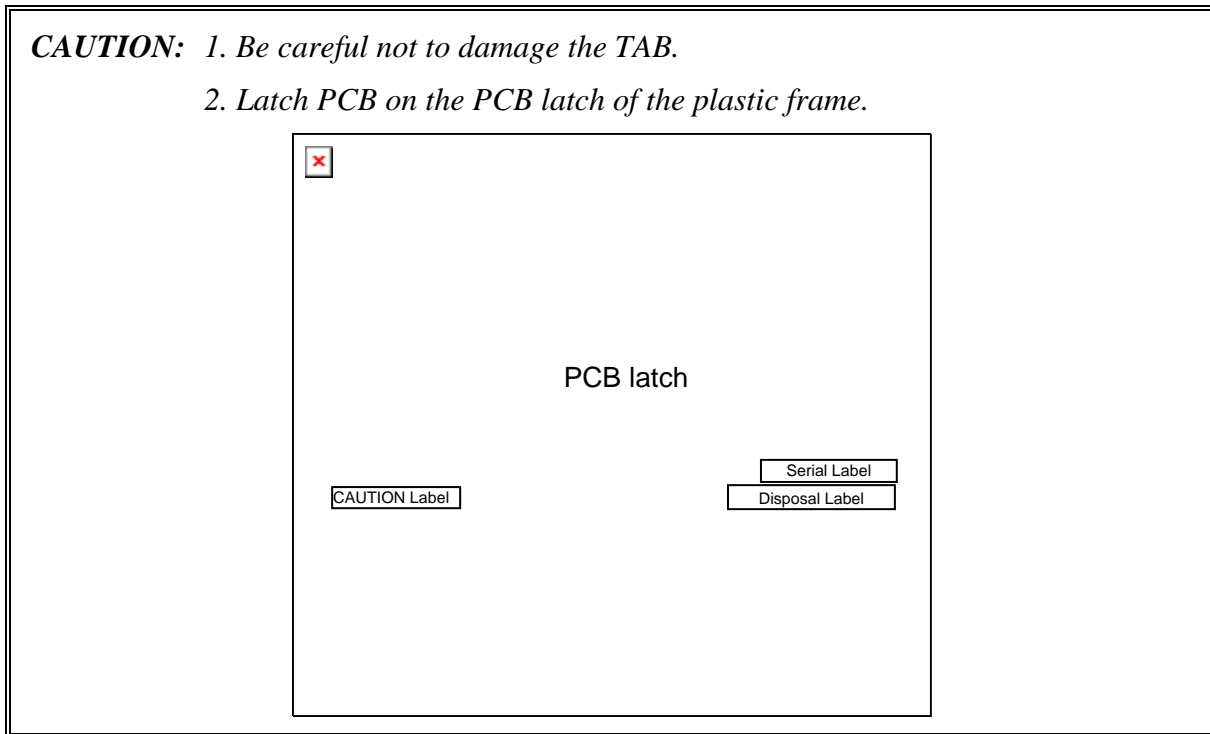

Figure 4-56 Replacing TMD fluorescent lamp (8)

Setting the bezel

1. Put the bezel on the top of the frame and latch at four points. ((1) in the bellow figure)
2. Put the bezel on the bottom of the frame and latch at three points. ((2) in the bellow figure)
3. Hold the bottom side lightly and stick a double-side tape.

CAUTION: Be careful not to damage the cell, TAB and B/L.

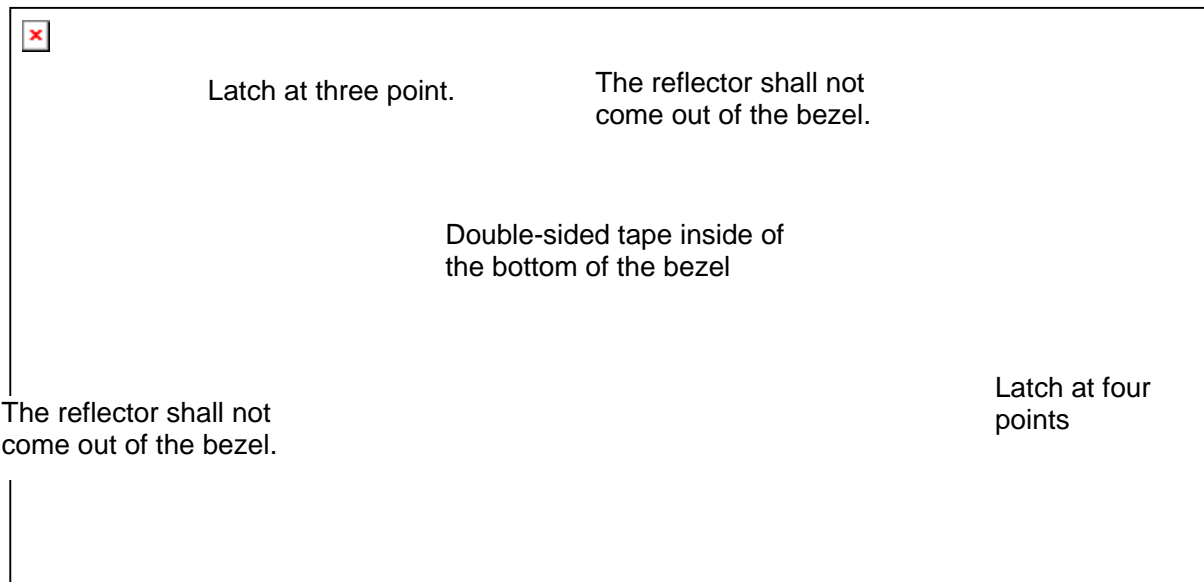

Figure 4-57 Replacing TMD fluorescent lamp (9)

Fixing the PCB and bezel

1. Fixing the PCB and bezel with four screws at the right side and left side (four points) as shown in the following figure.

CAUTION: 1. The tightening torque must be 0.167 N m (1.7kgf·cm) for all the screws.
There shall not be screw floating.
2. Use an insert bit of point size 0 for the Philips screwdrivers.

Attaching tapes and insulation sheet

1. Attach the double-sided tape of insulation sheet as shown in the following figure.

CAUTION: When attaching tape and insulation sheet, be careful not to damage the PCB, cell and B/L.

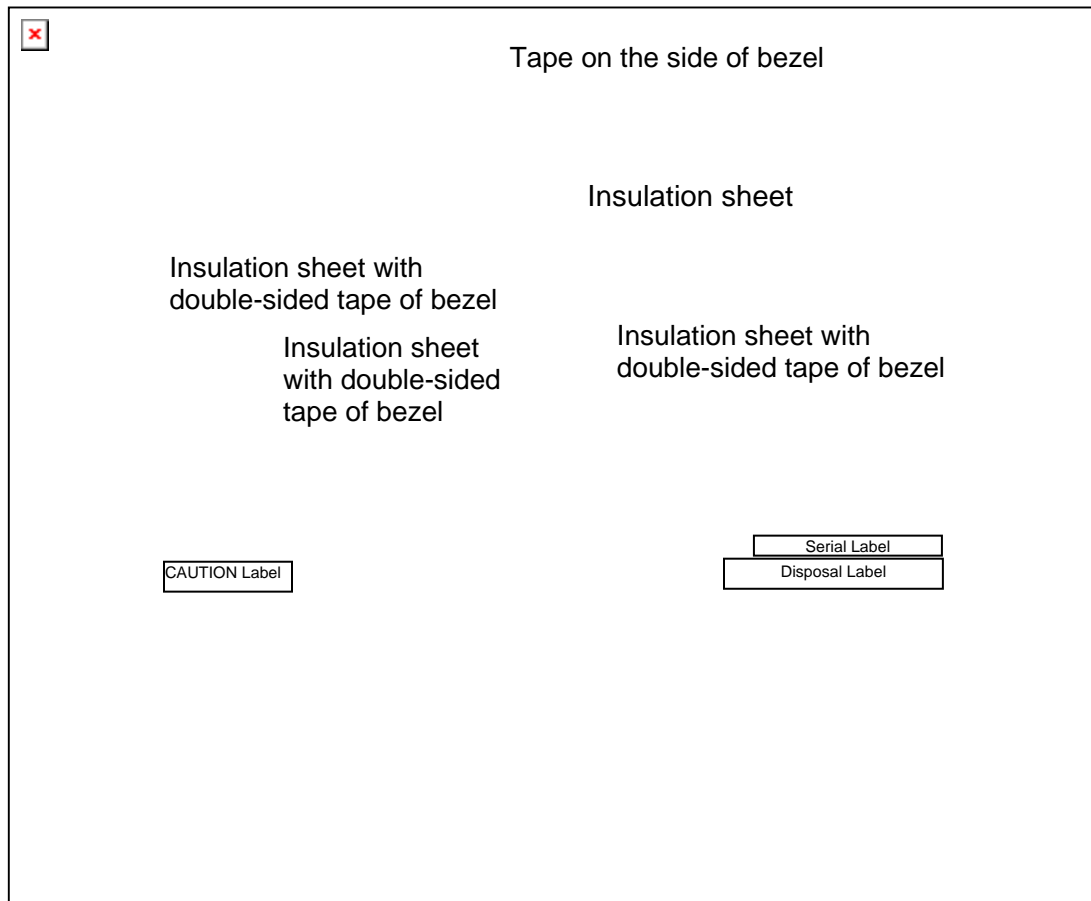

Figure 4-58 Replacing TMD fluorescent lamp (10)

4.29.2 Replacing the 12.1-inch WXGA Samsung Fluorescent Lamp

To replace the 12.1-inch WXGA Samsung fluorescent lamp, follow the steps below and refer to figures 4-59 to 4-62.

Removing the fluorescent lamp

1. Remove the PCB cover.

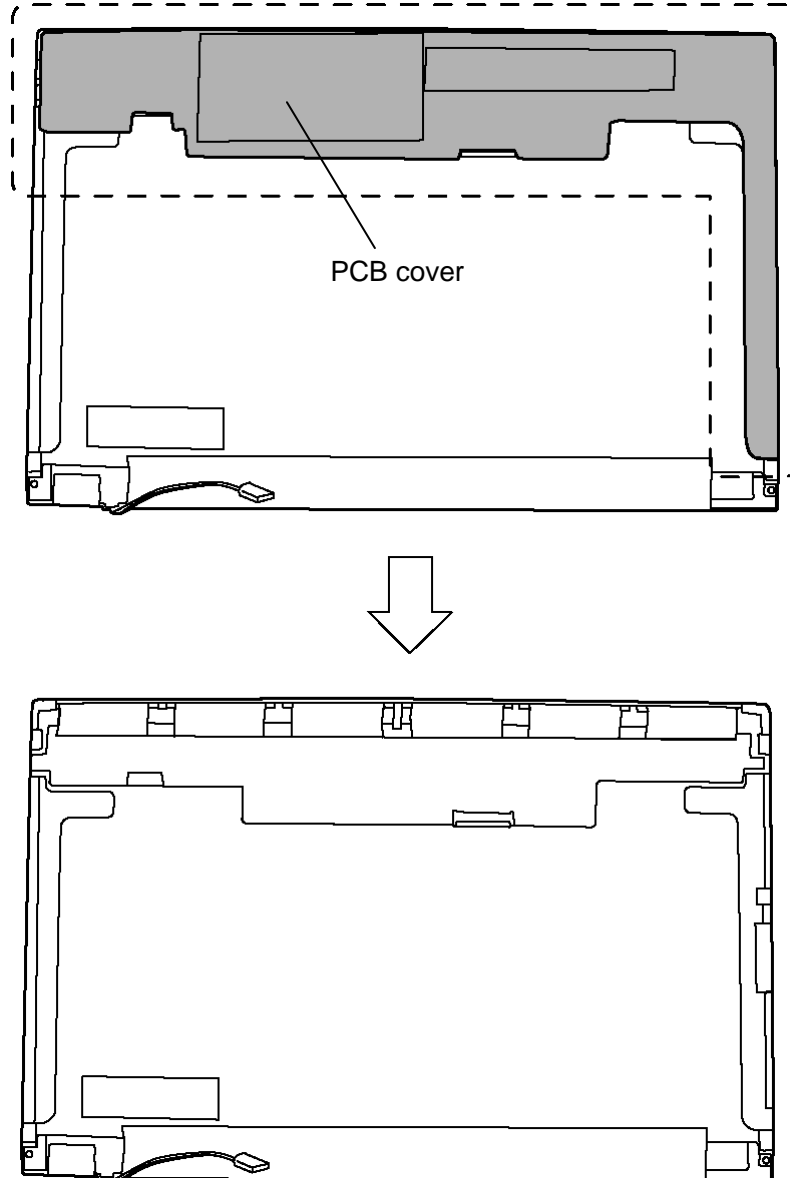

Figure 4-59 Replacing Samsung fluorescent lamp (1)

2. Remove the lamp-wire tape and Al tape.

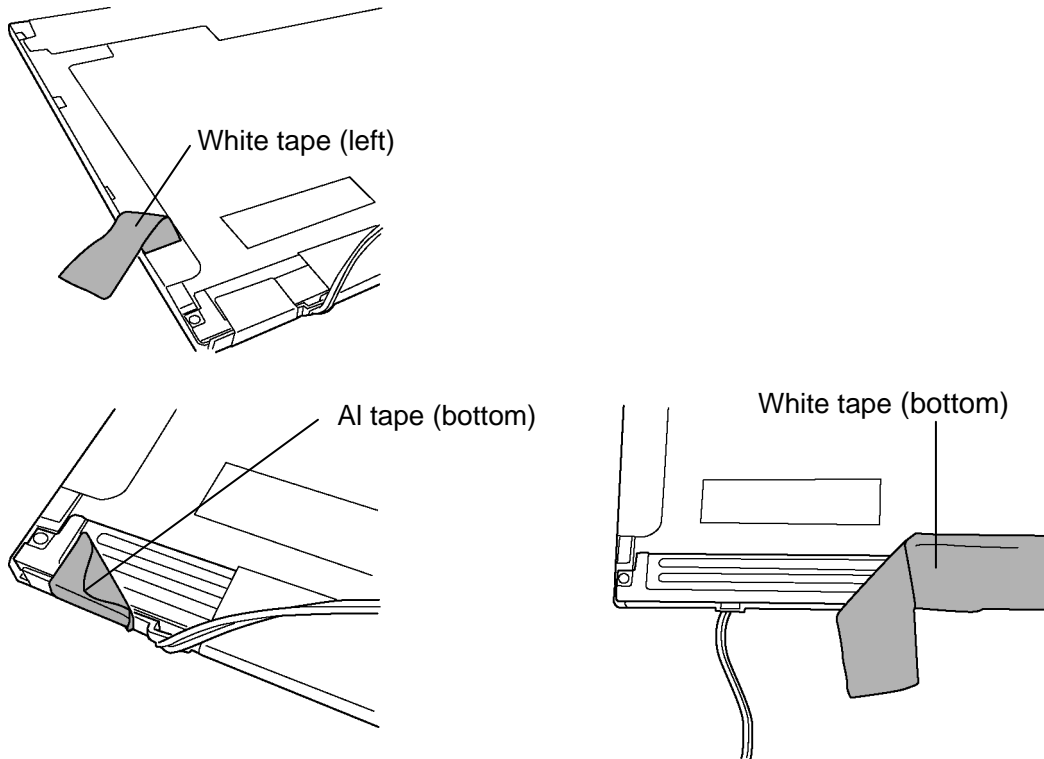
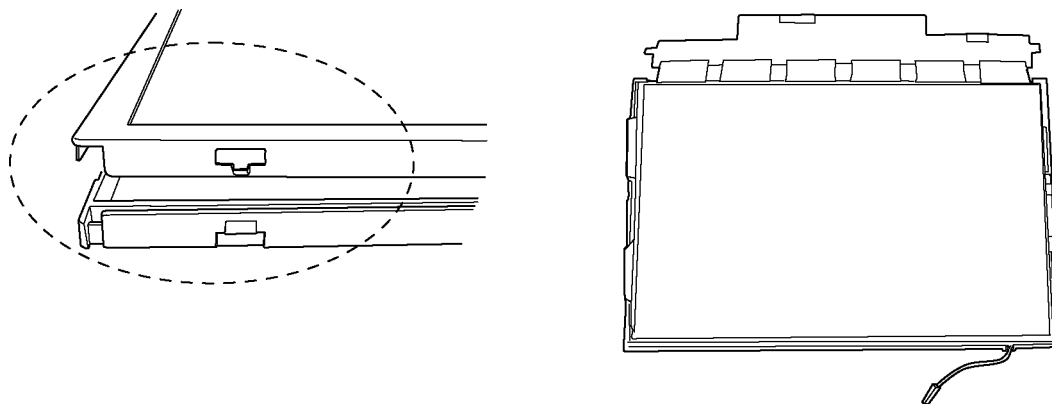

Figure 4-60 Replacing Samsung fluorescent lamp (2)

3. Remove the top chassis from the molded frame.

CAUTION: Remove in the order of bottom hook and side hook..



4. Separate the panel assembly and the backlight unit.

CAUTION: Handle with care not to damage the COF and G/D ICs.

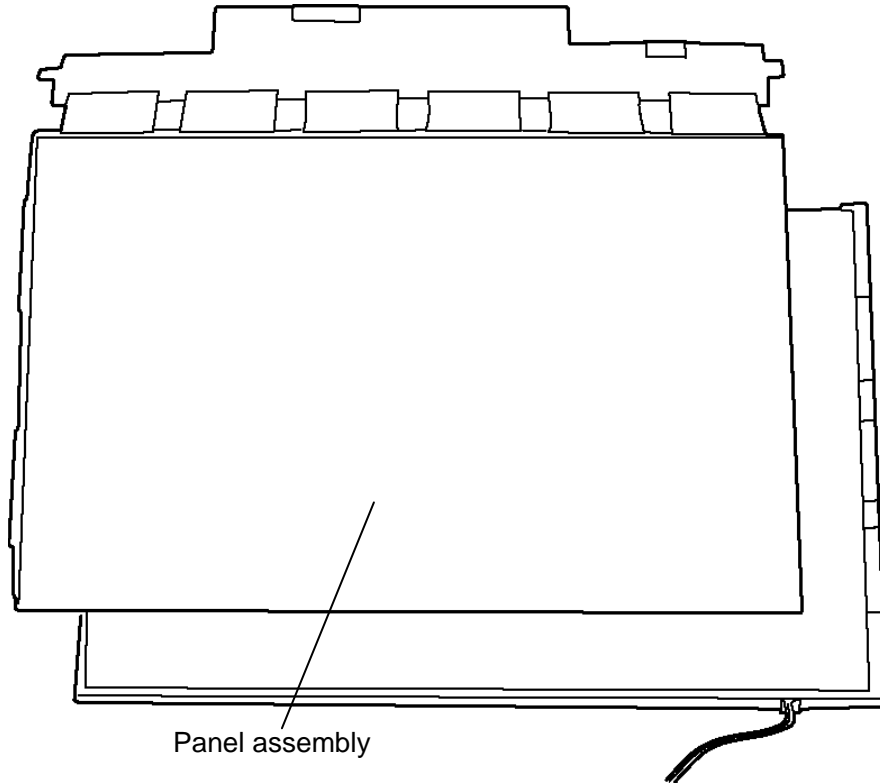

Figure 4-62 Replacing Samsung fluorescent lamp (4)

Assembling the fluorescent lamp

The assembly procedure of the 12.1-inch Samsung fluorescent lamp is the reverse of the above disassembly procedure. Refer to figures 4-59 to 4-62.

1. Install the panel assembly on the backlight unit.
2. Install the top chassis on the molded frame.
3. Stick the white tape and Al tape.
4. Stick the PCB cover.

Appendices

[CONFIDENTIAL]

Appendix Contents

Appendix A Handling the LCD Module	A-1
Appendix B Board Layout.....	B-1
B.1 System Board (FBMOS*) Front View	B-1
B.2 System Board (FBMOS*) Back View	B-3
B.3 Fingerprint Sensor Board (FBMOF*) Front and Back View.....	B-5
Appendix C Pin Assignments	C-1
System board	
C.1 CN1400 SO-DIMM A connector (200-pin).....	C-1
C.2 CN1410 SO-DIMM B connector (200-pin).....	C-4
C.3 CN1850 Main HDD interface connector (11-pin)	C-7
C.4 CN1810 ODD interface connector (50-pin)	C-8
C.5 CN2110 PC card interface connector (70-pin)	C-9
C.6 IS2101 MEDIA BRIDGE interface connector (42-pin)	C-10
C.7 CN2600 Wireless LAN card interface connector (52-pin)	C-11
C.8 CN3010 MDC interface connector (12-pin)	C-12
C.9 CN3200 Keyboard interface connector (34-pin)	C-12
C.10 CN3240 PAD interface connector (8-pin)	C-13
C.11 CN3260 SW membrane interface connector (13-pin)	C-13
C.12 CN4100 LAN interface connector (12-pin).....	C-13
C.13 CN3490 LPC debug port interface connector (12-pin)	C-14
C.14 CN4200 IEEE 1394 interface connector (4-pin)	C-14
C.15 CN4400 Bluetooth interface connector (20-pin)	C-14
C.16 CN4614 USB 6/4 connector (8-pin)	C-15
C.17 CN4614 USB 0 connector (4-pin)	C-15
C.18 CN5000 LCD interface connector (40-pin)	C-16
C.19 CN5080 RGB connector (15-pin).....	C-17
C.20 CN6050 Internal microphone connector (2-pin)	C-17
C.21 J6051 External microphone connector (5-pin)	C-17
C.22 CN6170 Speaker connector (4-pin)	C-17

C.23	J6310 Headphone connector (5-pin).....	C-18
C.24	CN8800 DC-IN connector (4-pin).....	C-18
C.25	CN8810 Main Battery connector (10-pin).....	C-18
C.26	CN9300 RTC Battery connector (3-pin).....	C-18
C.27	CN8771 FAN interface connector (4-pin)	C-19
C.28	CN9520 Fingerprint Sensor board interface connector (6-pin).....	C-19
Fingerprint Sensor Board		
C.29	CN9550 System board interface connector (6-pin)	C-25
Appendix D Keyboard Scan/Character Codes		D-1
Appendix E Key Layout.....		E-1
E.1	United Kingdom (UK) Keyboard	E-1
E.2	United States (US) Keyboard.....	E-1
Appendix F Wiring Diagrams		F-1
F.1	LAN Loopback Connector.....	F-1
F.2	RGB Monitor Loopback Connector.....	F-1
Appendix G BIOS rewrite Procedures		G-1
Appendix H EC/KBC rewrite Procedures.....		H-1
Appendix I Reliability		I-1

Figures

Figure B-1 System Board (FBMOS*) layout (front) B-1

Figure B-2 System Board (FBMOS*) layout (back) B-3

Figure B-3 Fingerprint Sensor Board (FBMOF*) layout (front/back) B-5

Figure E-1 UK keyboard..... E-1

Figure E-2 US keyboard..... E-1

Figure F-1 LAN Loopback Connector..... F-1

Figure F-2 RGB Monitor Loopback Connector F-1

Tables

Table B-1 System board (FBMOS*) ICs and connectors (front)..... B-2

Table B-2 System board (FBMOS*) connectors (back) B-4

Table B-3 Fingerprint Sensor board (FBMOF*) connector (back)..... B-5

System board

Table C-1 SO-DIMM A connector (200-pin) C-1

Table C-2 SO-DIMM B connector (200-pin)..... C-4

Table C-3 Main HDD interface connector (11-pin) C-7

Table C-4 ODD interface connector (50-pin)..... C-8

Table C-5 PC card interface connector (70-pin) C-9

Table C-6 MEDIA BRIDGE interface connector (42-pin) C-10

Table C-7 Wireless LAN card interface connector (52-pin) C-11

Table C-8 MDC interface connector (12-pin) C-12

Table C-9 Keyboard interface connector (34-pin) C-12

Table C-10 PAD interface connector (8-pin)..... C-13

Table C-11 SW membrane interface connector (13-pin) C-13

Table C-12 LAN interface connector (12-pin) C-13

Table C-13	LPC debug port interface connector (12-pin).....	C-14
Table C-14	IEEE 1394 interface connector (4-pin).....	C-14
Table C-15	Bluetooth interface connector (20-pin)	C-14
Table C-16	USB 6/4 connector (8-pin)	C-15
Table C-17	USB 0 connector (4-pin)	C-15
Table C-18	LCD interface connector (40-pin)	C-16
Table C-19	RGB connector (15-pin).....	C-17
Table C-20	Internal microphone connector (2-pin).....	C-17
Table C-21	External microphone connector (5-pin).....	C-17
Table C-22	Speaker connector (4-pin)	C-17
Table C-23	Headphone connector (5-pin).....	C-18
Table C-24	DC-IN connector (4-pin)	C-18
Table C-25	Main Battery connector (10-pin).....	C-18
Table C-26	RTC Battery connector (3-pin).....	C-18
Table C-27	FAN interface connector (4-pin).....	C-19
Table C-28	Fingerprint Sensor board interface connector (6-pin)	C-19
Finger print Sensor Board		
Table C-29	System board interface connector (6-pin)	C-25
Table D-1	Scan codes (set 1 and set 2)	D-1
Table D-2	Scan codes with left Shift key	D-5
Table D-3	Scan codes in Numlock mode	D-6
Table D-4	Scan codes with Fn key	D-6
Table D-5	Scan codes in overlay mode	D-7
Table D-6	No.124 key scan code.....	D-7
Table D-7	No.126 key scan code.....	D-8
Table I-1	MTBF	I-1

Appendix A Handling the LCD Module

Precautions for handling the LCD module

The LCD module can be easily damaged during assembly or disassembly. Observe the following precautions when handling the LCD module:

1. When installing the LCD module in the LCD cover, be sure to seat it so that it is properly aligned and maximum visibility of the display is maintained.

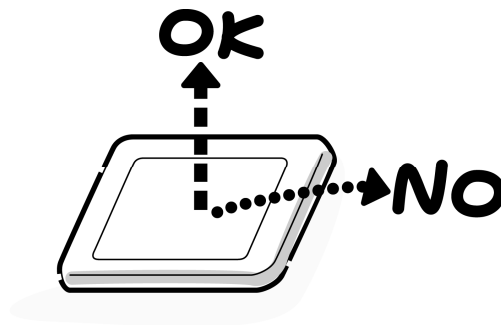

2. For the LCD module, be careful to align the four holes at the right side and left side of the LCD module with the corresponding holes in the LCD cover before securing the module with four screws.

Do not force the module into place, because stress can affect its performance. Also, the panel's surface is easily scarred, so be carefully when handling it.



3. If the panel's surface gets dirty, wipe it with cotton or a soft cloth. If it is still dirty, try breathing on the surface to create a light condensate and wipe it again.

If the surface is very dirty, we recommend a LCD cleaning agent. Apply the agent to a cloth and then wipe the panel's surface. Do not apply cleanser directly to the panel.



4. If water or other liquid is left on the panel's surface for a long period, it can change the screen's tint or stain it. Be sure to quickly wipe off any liquid.



5. Glass is used in the panel, so be careful not to drop it or let it strike a hard object, which could cause breakage or cracks.

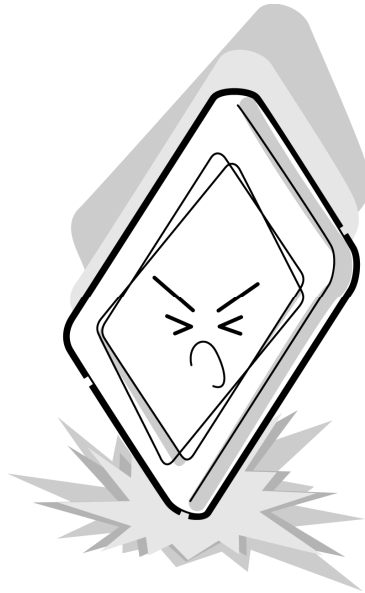

6. CMOS-LSI circuits are used in the module, so guard against damage from electrostatic discharge. Be sure to wear a wrist or ankle ground when handling the module.

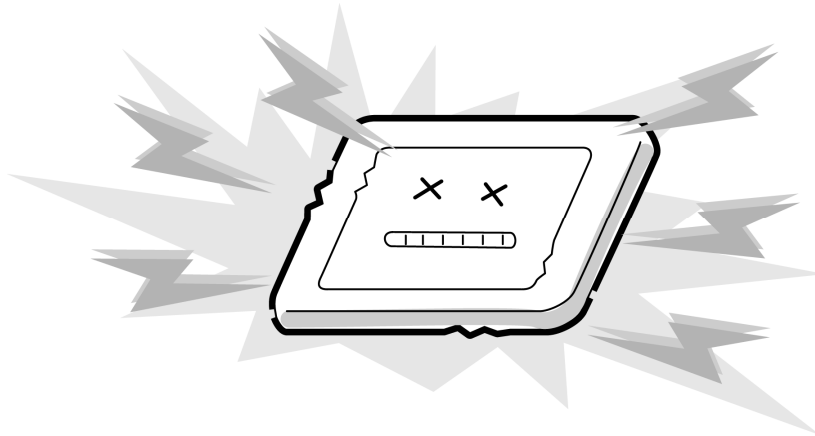

7. Do not expose the module to direct sunlight or strong ultraviolet rays for long periods.

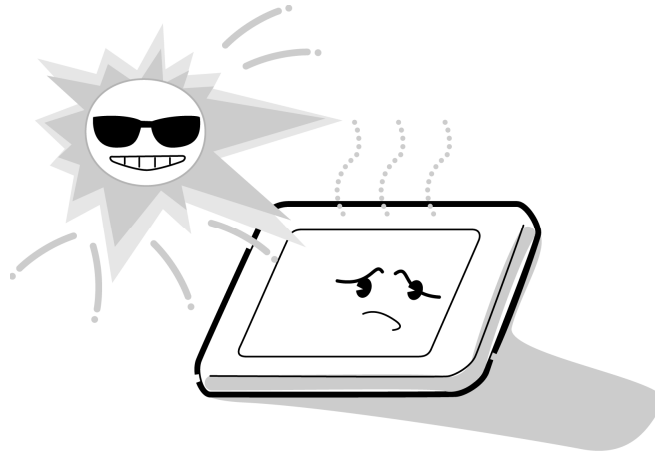

8. Do not store the module at temperatures below specifications. Cold can cause the liquid crystals to freeze, lose their elasticity or otherwise suffer damage.

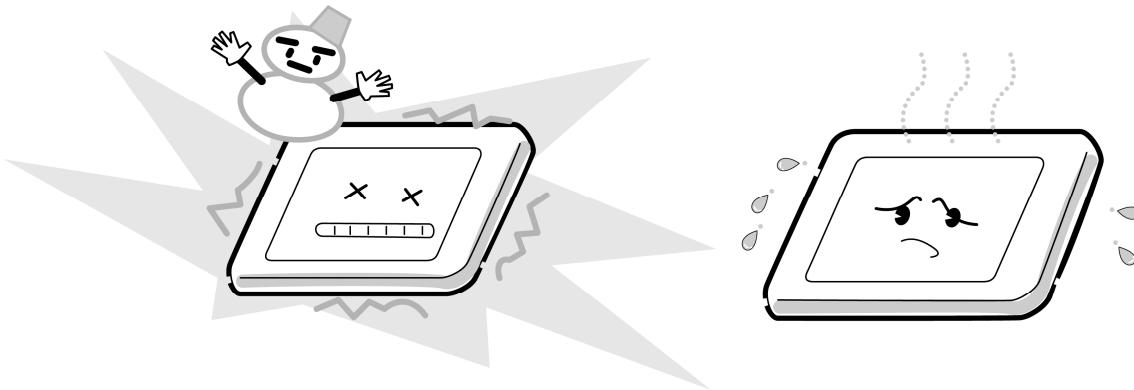

9. Do not disassemble the LCD module. Disassembly can cause malfunctions.

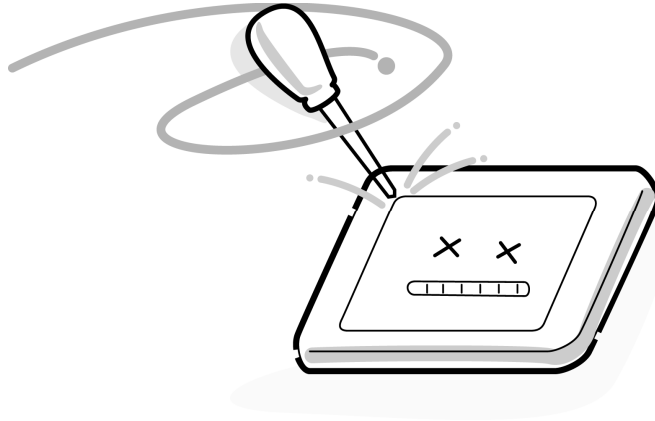

10. If you transport the module, do not use packing material that contains epoxy resin (amine) or silicon glue (alcohol or oxime). These materials can release gas that can damage the panel's polarization.

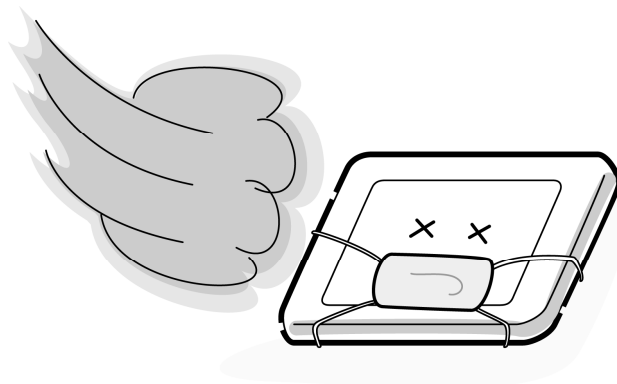

Appendix B Board Layout

B.1 System Board (FBMOS*) Front View

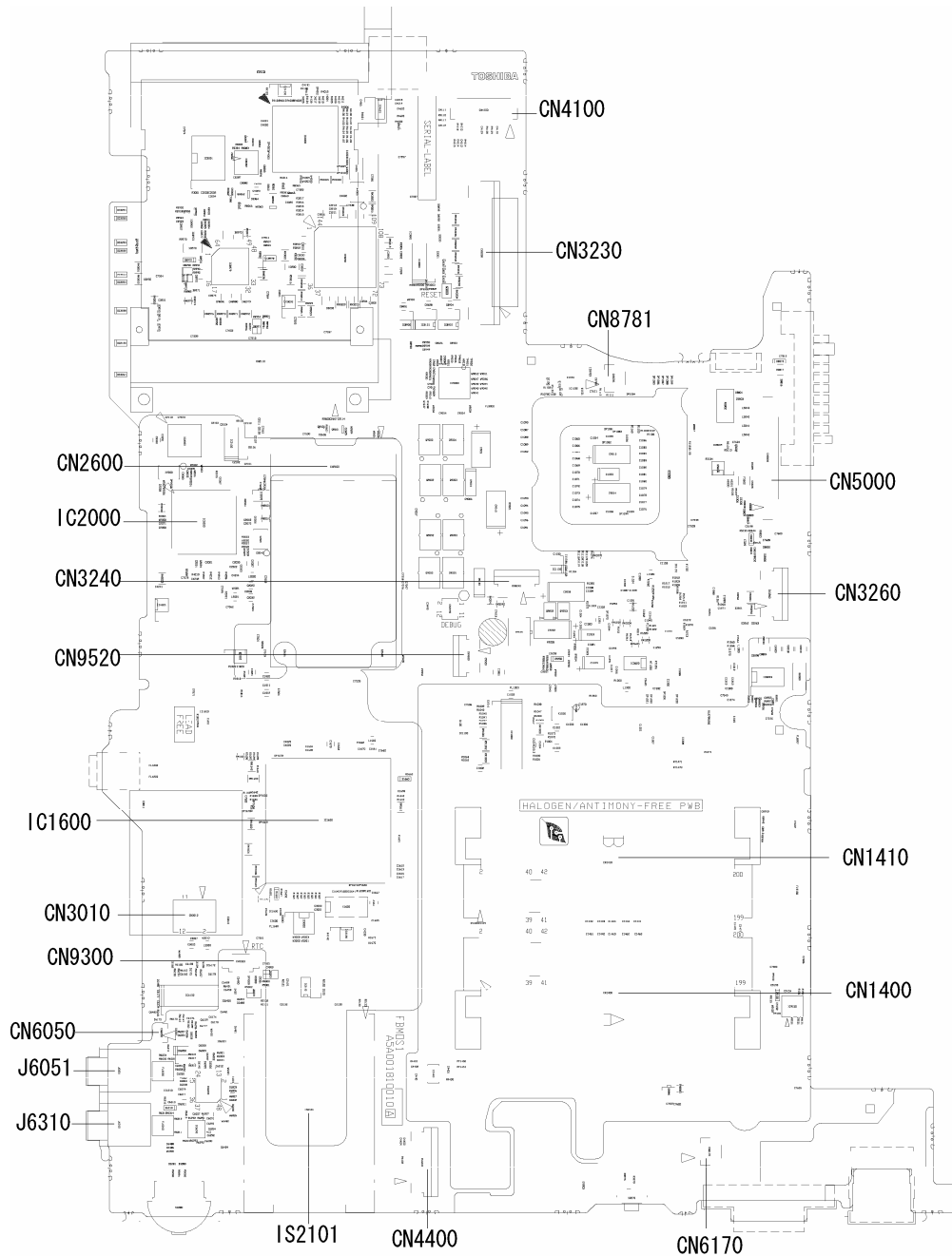

Figure B-1 System board (FBMOS*) layout (front)

Table B-1 System board (FBMOS*) ICs and connectors (front)

Number	Name
CN4100	LAN jack
CN3230	Keyboard connector
CN8781	Fan connector
CN2600	Wireless LAN card connector
IC2000	GMCH
CN3240	Touch pad connector
IC1600	ICH7-M
CN3010	MDC interface connector
CN9300	RTC battery connector
CN6050	Internal microphone connector
J6051	External microphone connector
J6310	Headphone connector
IS2101	Bridge media connector
CN4400	Bluetooth module connector
CN6170	Internal speaker connector
CN1400	Memory module A connector
CN1410	Memory module B connector
CN3260	SW membrane connector
CN5000	LCD connector
CN9520	Fingerprint sensor board connector

B.2 System Board (FBMOS*) Back View

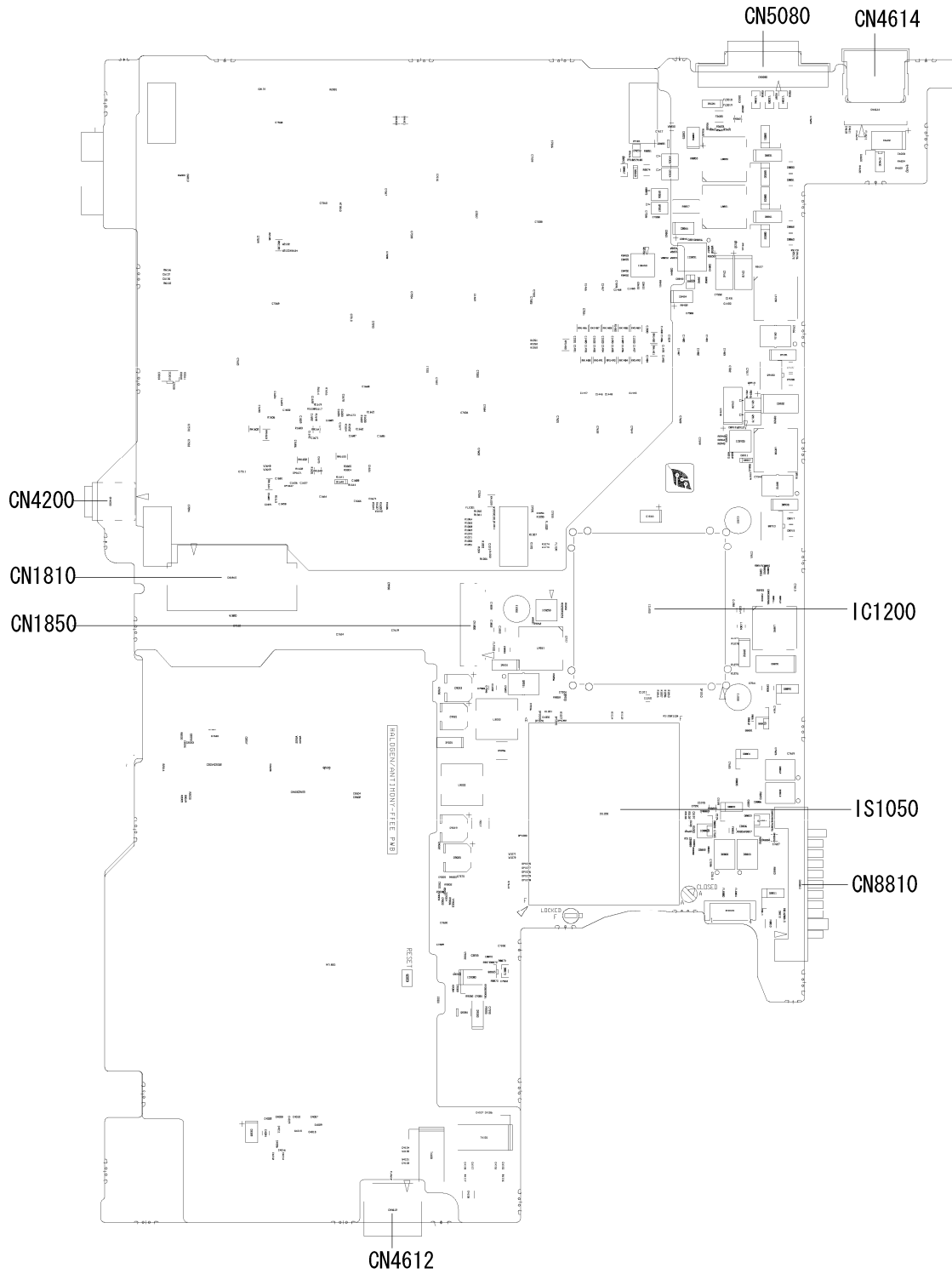

Figure B-2 System board (FBMOS*) layout (back)

Table B-2 System board (FBMOS*) connectors (back)

Number	Name
CN5080	RGB connector
CN4614	USB 6/4 port
CN4200	IEEE1394 port
CN1810	ODD connector
CN1850	HDD connector
CN4612	USB 0 port
CN8810	Main battery connector
IS1050	CPU socket
IS1200	GMCH

B.3 Fingerprint Sensor Board (FBMOF*) Front and Back View

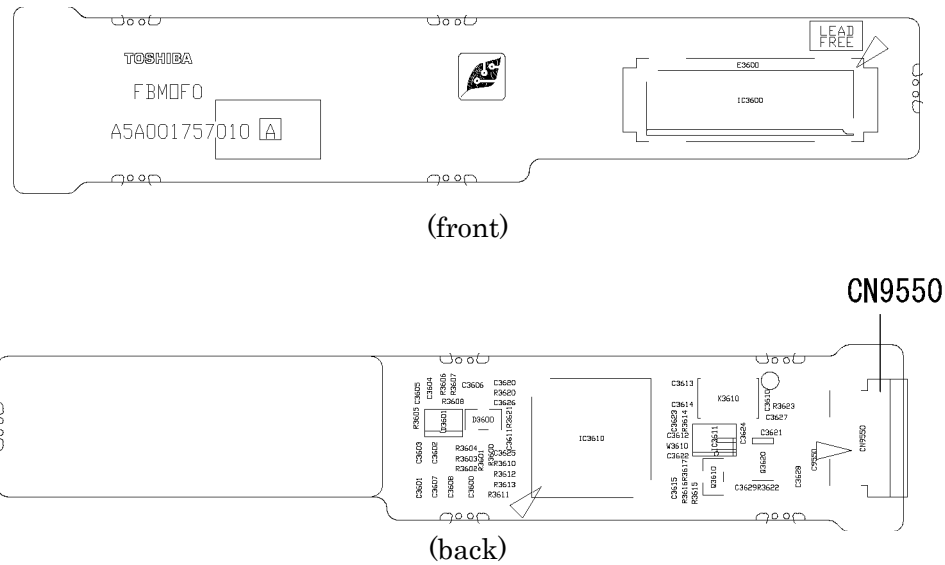

Figure B-3 Fingerprint Sensor Board (FBMOF*) layout (front/back)

Table B-3 Fingerprint Sensor Board (FBMOF*) connector (back)

Number	Name
CN9550	System board I/F connector

Appendix C Pin Assignments

System board

C.1 CN1400 SO-DIMM A connector (200-pin)

Table C-1 SO-DIMM A connector (200-pin) (1/3)

Pin No.	Signal Name	I/O	Pin No.	Signal Name	I/O
1	MRVREF-B0V	-	2	GND	-
3	GND	-	4	ADQ04-B1P	I/O
5	ADQ07-B1P	I/O	6	ADQ06-B1P	I/O
7	ADQ00-B1P	I/O	8	GND	-
9	GND	-	10	ADM0-B1P	I/O
11	ADQS0-B1N	I/O	12	GND	-
13	ADQS0-B1P	I/O	14	ADQ05-B1P	I/O
15	GND	-	16	ADQ01-B1P	I/O
17	ADQ03-B1P	I/O	18	GND	-
19	ADQ02-B1P	I/O	20	ADQ12-B1P	I/O
21	GND	-	22	ADQ13-B1P	I/O
23	ADQ14-B1P	I/O	24	GND	-
25	ADQ08-B1P	I/O	26	ADM1-B1P	I/O
27	GND	-	28	GND	-
29	ADQS1-B1N	I/O	30	MCK0-B1P	O
31	ADQS1-B1P	I/O	32	MCK0-B1N	O
33	GRD	-	34	GND	-
35	ADQ15-B1P	I/O	36	ADQ10-B1P	I/O
37	ADQ09-B1P	I/O	38	ADQ11-B1P	I/O
39	GND	-	40	GND	-
41	GND	-	42	GND	-
43	ADQ21-B1P	I/O	44	ADQ17-B1P	I/O
45	ADQ20-B1P	-	46	ADQ16-B1P	I/O
47	GND	-	48	GND	-
49	ADQS2-B1N	I/O	50	NC	-
51	ADQS2-B1P	I/O	52	ADM2-B1P	I/O
53	GND	-	54	GND	-
55	ADQ23-B1P	I/O	56	ADQ18-B1P	I/O
57	ADQ19-B1P	I/O	58	ADQ22-B1P	I/O
59	GND	-	60	GND	-
61	ADQ25-B1P	I/O	62	ADQ29-B1P	I/O

Table C-1 SO-DIMM A connector (200-pin) (2/3)

Pin No.	Signal Name	I/O	Pin No.	Signal Name	I/O
63	ADQ28-B1P	I/O	64	ADQ24-B1P	I/O
65	GND	-	66	GND	-
67	ADM3-B1P	I/O	68	ADQS3-B1N	I/O
69	NC	-	70	ADQS3-B1P	I/O
71	GND	-	72	GND	-
73	ADQ30-B1P	I/O	74	ADQ27-B1P	I/O
75	ADQ26-B1P	I/O	76	ADQ31-B1P	I/O
77	GND	-	78	GND	-
79	MCKE0-B1P	O	80	MCKE1-B1P	O
81	1R8-B1V	-	82	1R8-B1V	-
83	NC	-	84	NC	-
85	ABS2-B1P	O	86	NC	-
87	1R8-B1V	-	88	1R8-B1V	-
89	AMA12-B1P	O	90	AMA11-B1P	O
91	AMA09-B1P	O	92	AMA07-B1P	O
93	AMA08-B1P	O	94	AMA06-B1P	O
95	1R8-B1V	-	96	1R8-B1V	I
97	AMA05-B1P	O	98	AMA04-B1P	O
99	AMA03-B1P	O	100	AMA02-B1P	O
101	AMA01-B1P	O	102	AMA00-B1P	O
103	1R8-B1V	-	104	1R8-B1V	-
105	AMA10-B1P	O	106	ABS1-B1P	O
107	ABS0-B1P	O	108	ARAS-B1N	I
109	AWE-B1N	I	110	MCS0-B1N	O
111	1R8-B1V	-	112	1R8-B1V	-
113	ACAS-B1N	O	114	MODT0-B1P	O
115	MCS1-B1N	O	116	AMA13-B1P	I/O
117	1R8-B1V	-	118	1R8-B1V	-
119	MODT1-B1P	O	120	NC	-
121	GND	-	122	GND	-
123	ADQ34-B1P	I/O	124	ADQ36-B1P	I/O
125	ADQ33-B1P	I/O	126	ADQ37-B1P	I/O
127	GND	-	128	GND	-
129	ADQS4-B1N	I/O	130	ADM4-B1P	O
131	ADQS4-B1P	I/O	132	GND	-

Table C-1 SO-DIMM A connector (200-pin) (3/3)

Pin No.	Signal Name	I/O	Pin No.	Signal Name	I/O
133	GND	-	134	ADQ35-B1P	I/O
135	ADQ39-B1P	I/O	136	ADQ32-B1P	I/O
137	ADQ38-B1P	I/O	138	GND	-
139	GND	-	140	ADQ44-B1P	I/O
141	ADQ40-B1P	I/O	142	ADQ41-B1P	I/O
143	ADQ45-B1P	I/O	144	GND	-
145	GND	-	146	ADQS5-B1N	I/O
147	ADM5-B1P	O	148	ADQS5-B1P	I/O
149	GND	-	150	GND	-
151	ADQ42-B1P	I/O	152	ADQ46-B1P	I/O
153	ADQ43-B1P	I/O	154	ADQ47-B1P	I/O
155	GND	-	156	GND	-
157	ADQ48-B1P	I/O	158	ADQ52-B1P	I/O
159	ADQ49-B1P	I/O	160	ADQ53-B1P	I/O
161	GND	-	162	GND	-
163	NC	-	164	MCK1-B1P	O
165	GND	-	166	MCK1-B1N	O
167	ADQS6-B1N	I/O	168	GND	-
169	ADQS6-B1P	I/O	170	ADM6-B1P	O
171	GND	-	172	GND	-
173	ADQ55-B1P	I/O	174	ADQ54-B1P	I/O
175	ADQ51-B1P	I/O	176	ADQ50-B1P	I/O
177	GND	-	178	GND	-
179	ADQ56-B1P	I/O	180	ADQ60-B1P	I/O
181	ADQ57-B1P	I/O	182	ADQ61-B1P	I/O
183	GND	-	184	GND	-
185	ADM7-B1P	O	186	ADQS7-B1N	I/O
187	GND	-	188	ADQS7-B1P	I/O
189	ADQ58-B1P	I/O	190	GND	-
191	ADQ62-B1P	I/O	192	ADQ59-B1P	I/O
193	GND	-	194	ADQ63-B1P	I/O
195	SMBDA0-P3P	I/O	196	GND	-
197	SMBCK0-P3P	I/O	198	GND	-
199	P3V	-	200	GND	-
1T	GND	-	2T	GND	-

C.2 CN1410 SO-DIMM B connector (200-pin)*Table C-2 SO-DIMM B connector (200-pin) (1/3)*

Pin No.	Signal Name	I/O	Pin No.	Signal Name	I/O
1	MRBREF-B0V	-	2	GND	-
3	GND	-	4	BDQ01-B1P	I/O
5	BDQ02-B1P	I/O	6	BDQ04-B1P	I/O
7	BDQ06-B1P	I/O	8	GND	-
9	GND	-	10	BDM0-B1P	I/O
11	BDQS0-B1N	I/O	12	GND	-
13	BDQS0-B1P	I/O	14	BDQ05-B1P	I/O
15	GND	-	16	BDQ00-B1P	I/O
17	BDQ03-B1P	I/O	18	GND	-
19	BDQ07-B1P	I/O	20	BDQ12-B1P	I/O
21	GND	-	22	BDQ13-B1P	I/O
23	BDQ08-B1P	I/O	24	GND	-
25	BDQ09-B1P	I/O	26	BDM1-B1P	I/O
27	GND	-	28	GND	-
29	BDQS1-B1N	I/O	30	MCK3-B1P	O
31	BDQS1-B1P	I/O	32	MCK3-B1N	O
33	GND	-	34	GND	-
35	BDQ10-B1P	I/O	36	BDQ14-B1P	I/O
37	BDQ11-B1P	I/O	38	BDQ15-B1P	I/O
39	GND	-	40	GND	-
41	GND	-	42	GND	-
43	BDQ16-B1P	I/O	44	BDQ17-B1P	I/O
45	BDQ21-B1P	-	46	BDQ20-B1P	I/O
47	GND	-	48	GND	-
49	BDQS2-B1N	I/O	50	NC	-
51	BDQS2-B1P	I/O	52	BDM2-B1P	I/O
53	GND	-	54	GND	-
55	BDQ23-B1P	I/O	56	BDQ18-B1P	I/O
57	BDQ22-B1P	I/O	58	BDQ19-B1P	I/O
59	GND	-	60	GND	-
61	BDQ29-B1P	I/O	62	BDQ25-B1P	I/O

Table C-2 SO-DIMM B connector (200-pin) (2/3)

Pin No.	Signal Name	I/O	Pin No.	Signal Name	I/O
63	BDQ28-B1P	I/O	64	BDQ24-B1P	I/O
65	GND	-	66	GND	-
67	BDM3-B1P	I/O	68	BDQS3-B1N	I/O
69	NC	-	70	BDQS3-B1P	I/O
71	GND	-	72	GND	-
73	BDQ26-B1P	I/O	74	BDQ30-B1P	I/O
75	BDQ27-B1P	I/O	76	BDQ31-B1P	I/O
77	GND	-	78	GND	-
79	MCKE2-B1P	O	80	MCKE3-B1P	O
81	1R8-B1V	-	82	1R8-B1V	-
83	NC	-	84	NC	-
85	BBS2-B1P	O	86	NC	-
87	1R8-B1V	-	88	1R8-B1V	-
89	BMA12-B1P	O	90	BMA11-B1P	O
91	BMA09-B1P	O	92	BMA07-B1P	O
93	BMA08-B1P	O	94	BMA06-B1P	O
95	1R8-B1V	-	96	1R8-B1V	I
97	BMA05-B1P	O	98	BMA04-B1P	O
99	BMA03-B1P	O	100	BMA02-B1P	O
101	BMA01-B1P	O	102	BMA00-B1P	O
103	1R8-B1V	-	104	1R8-B1V	-
105	BMA10-B1P	O	106	BBS1-B1P	O
107	BBS0-B1P	O	108	BRAS-B1N	I
109	BWE-B1N	I	110	MCS2-B1N	O
111	1R8-B1V	-	112	1R8-B1V	-
113	BCAS-B1N	-	114	MODT2-B1P	O
115	MCS3-B1N	O	116	BMA13-B1P	I/O
117	1R8-B1V	-	118	1R8-B1V	-
119	MODT3-B1P	O	120	NC	-
121	GND	-	122	GND	-
123	BDQ32-B1P	I/O	124	BDQ36-B1P	I/O
125	BDQ33-B1P	I/O	126	BDQ37-B1P	I/O
127	GND	-	128	GND	-
129	BDQS4-B1N	I/O	130	BDM4-B1P	O
131	BDQS4-B1P	I/O	132	GND	-
133	GND	-	134	BDQ38-B1P	I/O

Table C-2 SO-DIMM B connector (200-pin) (3/3)

Pin No.	Signal Name	I/O	Pin No.	Signal Name	I/O
135	BDQ34-B1P	I/O	136	BDQ39-B1P	I/O
137	BDQ35-B1P	I/O	138	GND	-
139	GND	-	140	BDQ44-B1P	I/O
141	BDQ40-B1P	I/O	142	BDQ45-B1P	I/O
143	BDQ41-B1P	I/O	144	GND	-
145	GND	-	146	BDQS5-B1N	I/O
147	BDM5-B1P	O	148	BDQS5-B1P	I/O
149	GND	-	150	GND	-
151	BDQ47-B1P	I/O	152	BDQ46-B1P	I/O
153	BDQ42-B1P	I/O	154	BDQ43-B1P	I/O
155	GND	-	156	GND	-
157	BDQ48-B1P	I/O	158	BDQ53-B1P	I/O
159	BDQ52-B1P	I/O	160	BDQ49-B1P	I/O
161	GND	-	162	GND	-
163	NC	-	164	MCK2-B1P	O
165	GND	-	166	MCK2-B1N	O
167	BDQS6-B1N	I/O	168	GND	-
169	BDQS6-B1P	I/O	170	BDM6	O
171	GND	-	172	GND	-
173	BDQ51-B1P	I/O	174	BDQ50-B1P	I/O
175	BDQ54-B1P	I/O	176	BDQ55-B1P	I/O
177	GND	-	178	GND	-
179	BDQ57-B1P	I/O	180	BDQ56-B1P	I/O
181	BDQ61-B1P	I/O	182	BDQ60-B1P	I/O
183	GND	-	184	GND	-
185	BDM7-B1P	O	186	BDQS7-B1N	I/O
187	GND	-	188	BDQS7-B1P	I/O
189	BDQ58-B1P	I/O	190	GND	-
191	BDQ59-B1P	I/O	192	BDQ62-B1P	I/O
193	GND	-	194	BDQ63-B1P	I/O
195	SMBDA0-P3P	I/O	196	GND	-
197	SMBCK0-P3P	I/O	198	GND	-
199	P3V	-	200	P3V	-
1T	GND	-	2T	GND	-

C.3 CN1850 Main HDD interface connector (11-pin)

Table C-3 Main HDD interface connector (11-pin)

Pin No.	Signal Name	I/O	Pin No.	Signal Name	I/O
1	ZSATT0-P1P	O	2	ZSATT0-P1N	O
3	GND	-	4	ZSATR0-P1N	I
5	ZSATR0-P1P	I	6	GND	-
7	P3V	-	8	GND	-
9	P5V	-	10	GND	-
11	GND	-			
1T	GND	-	2T	GND	-
3T	GND	-	4T	GND	-

C.4 CN1810 ODD interface connector (50-pin)

Table C-4 ODD interface connector (50-pin)

Pin No.	Signal Name	I/O	Pin No.	Signal Name	I/O
1	NC	-	2	NC	-
3	GND	-	4	NC	-
5	PLTRS0-E3N + RSTTIDB-P3N	O	6	PDD08-P3P	I/O
7	PDD07-P3P	I/O	8	PDD09-P3P	I/O
9	PDD06-P3P	I/O	10	PDD10-P3P	I/O
11	PDD05-P3P	I/O	12	PDD11-P3P	I/O
13	PDD04-P3P	I/O	14	PDD12-P3P	I/O
15	PDD03-P3P	I/O	16	PDD13-P3P	I/O
17	PDD02-P3P	I/O	18	PDD14-P3P	I/O
19	PDD01-P3P	I/O	20	PDD15-P3P	I/O
21	PDD00-P3P	I/O	22	PDDREQ-P3P	I
23	GND	-	24	PDIOR-P3N	O
25	PDIOW-P3N	O	26	GND	-
27	PIORDY-P3P	I	28	PDDACK	-
29	IDEIRQ-P3P	I	30	NC	-
31	PDA1-P3N	O	32	NC	-
33	PDA0-P3P	O	34	PDA2-P3N	O
35	PDCS1-P3N	O	36	NC	-
37	NC	-	38	SB-P5V	-
39	SB-P5V	-	40	SB-P5V	-
41	SB-P5V	-	42	SB-P5V	-
43	GND	-	44	GND	-
45	GND	-	46	GND	-
47	NC	-	48	GND	-
49	NC	-	50	NC	I

C.5 CN2110 PC card interface connector (70-pin)*Table C-5 PC card interface connector (70-pin)*

Pin No.	Signal Name	I/O	Pin No.	Signal Name	I/O
1	GND	-	2	ACAD00-EYP	I/O
3	ACAD01-PYP	I/O	4	ACAD03-PYP	I/O
5	ACAD05-PYP	I/O	6	ACAD07-PYP	I/O
7	ACCBEO-PYN	I/O	8	ACAD09-PYP	I/O
9	ACAD11-PYP	I/O	10	ACAD12-PYP	I/O
11	ACAD14-PYP	I/O	12	ACCBE1-PYN	I/O
13	ACPAR-PYP	I/O	14	ACPERR-PYN	I/O
15	ACGNT-PYN	I/O	16	ACINT-PYN	I/O
17	MCVCCA-PYV	I/O	18	MCVPPA-PYV	I/O
19	ACCLK-PYP	I/O	20	ACIRDY-PYN	I/O
21	ACCBE2-PYN	I/O	22	ACAD18-PYP	I/O
23	ACAD20-PYP	I/O	24	ACAD21-PYP	I/O
25	ACAD22-PYP	I/O	26	ACAD23-PYP	I/O
27	ACAD24-PYP	I/O	28	ACAD25-PYP	I/O
29	ACAD26-PYP	I/O	30	ACAD27-PYP	I/O
31	ACAD29-PYP	I/O	32	ACD02-PYP	I/O
33	ACCLKR-PYN	I/O	34	GND	-
35	GND	-	36	ACCD1-P3N	I/O
37	ACAD02-PYP	I/O	38	ACAD04-PYP	I/O
39	ACAD06-PYP	I/O	40	ACD14-PYP	I/O
41	ACAD08-PYP	I/O	42	ACAD10-PYP	I/O
43	ACVS1-P3P	I/O	44	ACD13-PYP	I/O
45	ACD15-PYP	I/O	46	ACD16-PYP	I/O
47	ACA18-PYP	I/O	48	ACLOCK-PYP	I/O
49	ACSTOP-PYP	I/O	50	ACDEVS-PYP	I/O
51	MCVPPA-PYV	-	52	MCVPPA-PYV	-
53	ACTRDY-PYN	I/O	54	ACFRAM-PYN	I/O
55	ACD17-PYP	I/O	56	ACD19-PYP	I/O
57	ACVS2-P3P	I/O	58	ACRST-PYN	I/O
59	ACSERR-PYN	I/O	60	ACREQ-PYN	I/O
61	ACCBE3-PYN	I/O	62	ACAUDI-PYP	I
63	ACSTSC-PYP	I	64	ACD28-PYP	I/O
65	ACD30PYP	I/O	66	ACD31-PYP	I/O
67	ACCD2-P3N	-	68	GND	-
69	GND	-	70	GND	-

C.6 IS2101 MEDIA BRIDGE interface connector (42-pin)

Table C-6 MEDIA BRIDGE interface connector (42-pin)

Pin No.	Signal Name	I/O	Pin No.	Signal Name	I/O
1	MSDAT2-P3P	I/O	2	MSDAT3-P3P	I/O
3	MSBS-P3P	I/O	4	GND	-
5	GND	-	6	FM-P3V	I
7	MSCLK-P3P	I/O	8	MSDAT3-P3P	I/O
9	MSCD-P3N	O	10	MSDAT2-P3P	I/O
11	MSSDIO-P3P	I/O	12	MSDAT1-P3P	I/O
13	MSBS-P3P	I/O	14	GND	-
15	FM-P3V	I	16	MSCLK-P3P	I/O
17	GND	-	18	MSSDIO-P3P	I/O
19	MSSDAT1-P3P	I/O	20	SM-P3V	I
21	SDAT3-P3P	I/O	22	SDAT2-P3P	I/O
23	SDAT1-P3P	I/O	24	SDAT0-P3P	I/O
25	MSDAT3-P3P	I/O	26	MSDAT2-P3P	I/O
27	MSDAT1-P3P	I/O	28	MSSDIO-P3P	I/O
29	GND	-	30	MSCLK-P3P	I/O
31	MXDWE-P3N	I	32	SDCMD-P3P	I/O
33	SMCLE-P3P	I/O	34	MXDCE-P3N	I
35	MXDRE-P3N	I	36	SMRDY-P3P	I
37	MXDCD-P3N	I	38	GND	-
39	GND	-	40	SDCD-P3N	O
41	GND	-	42	SDWP-P3P	O
1T	GND	-	2T	GND	-
3T	GND	-	4T	GND	-

C.7 CN2600 Wireless LAN card interface connector (52-pin)*Table C-7 Wireless LAN card interface connector (52-pin)*

Pin No.	Signal Name	I/O	Pin No.	Signal Name	I/O
1	PEWAKE-E3N	I	2	P3V	-
3	WCHDAT-P3P	O	4	GND	-
5	WCHCLK-P3P	O	6	1R5-P1V	-
7	MPEXRQ-P3N	I	8	NC	-
9	GND	-	10	NC	-
11	XPEWL-P3N	O	12	NC	-
13	XPEWL-P3P	O	14	NC	-
15	GND	-	16	NC	-
17	NC	-	18	GND	-
19	NC	-	20	(WLRFON-S3N)	O
21	GND	-	22	PLTRS1-E3N	-
23	ZPERWL-P1N	I	24	E3V	-
25	ZPERWL-P1P	I	26	GND	-
27	GND	-	28	1R5-P1V	-
29	GND	-	30	SMBCK0-P3P	O
31	ZPETWL-P1N	O	32	SMBDA0-P3P	O
33	ZPETWL-P1P	O	34	GND	-
35	GND	-	36	NC	-
37	NC	-	38	NC	-
39	NC	-	40	GND	-
41	NC	-	42	NC	-
43	NC	-	44	NC	-
45	NC	-	46	NC	-
47	NC	-	48	1R5-P1V	-
49	NC	-	50	GND	-
51	NC	-	52	P3V	-
1T	GND	-	2T	GND	-

C.8 CN3010 MDC interface connector (12-pin)*Table C-8 MDC interface connector (12-pin)*

Pin No.	Signal Name	I/O	Pin No.	Signal Name	I/O
1	GND	-	2	NC	-
3	ACZOT1-P3P	I/O	4	NC	-
5	GND	-	6	E3V	-
7	ACZSY1-P3P	O	8	GND	-
9	ACZIN1-E3P	I/O	10	GND	-
11	ACZRS1-E3N	O	12	XAZBC1-P3P	O
1T	GND	-	2T	GND	-
3T	GND	-	4T	GND	-
5T	GND	-	6T	GND	-

C.9 CN3200 Keyboard interface connector (34-pin)*Table C-9 Keyboard interface connector (34-pin)*

Pin No.	Signal Name	I/O	Pin No.	Signal Name	I/O
1	NUMLED-P5N	I	2	ARWLED-P5N	I
3	CAPLED-P5N	I	4	P5V	I
5	KBSC00-S3N	O	6	KBSC01-S3N	O
7	KBSC02-S3N	O	8	KBSC03-S3N	O
9	KBSC04-S3N	O	10	KBSC05-S3N	O
11	KBSC06-S3N	O	12	KBRT00-S3N	O
13	KBSC07-S3N	O	14	KBSC08-S3N	O
15	KBSC09-S3N	O	16	KBRT01-S3N	O
17	KBRT02-S3N	O	18	KBRT03-S3N	O
19	KBSC10-S3N	O	20	KBSC11-S3N	O
21	KBRT04-S3N	O	22	KBRT05-S3N	O
23	KBSC12-S3N	O	24	KBSC13-S3N	O
25	KBRT06-S3N	O	26	KBRT07-S3N	O
27	KBSC14-S3N	O	28	KBSC15-S3N	O
29	NC	-	30	NC	-
31	NC	-	32	NC	-
33	NC	-	34	NC	-
1T	GND	-	2T	GND	-

C.10 CN3240 PAD interface connector (8-pin)*Table C-10 PAD interface connector (8-pin)*

Pin No.	Signal Name	I/O	Pin No.	Signal Name	I/O
1	GND	-	2	GND	-
3	GND	-	4	NC	-
5	IPDCLK-P5P	I/O	6	IPDDAT-P5P	I/O
7	P5V	-	8	P5V	I
1T	GND	-	2T	GND	-

C.11 CN3260 SW membrane interface connector (13-pin)*Table C-11 SW membrane interface connector (13-pin)*

Pin No.	Signal Name	I/O	Pin No.	Signal Name	I/O
1	PNLOFF-S3N	I	2	NC	-
3	NC	-	4	CDNEXT-S3N	I
5	CDPREV-S3N	I	6	GPBTNB-S3N	I
7	CDPLAY-S3N	I	8	CDSTOP-S3N	I
9	GPBTNA-S3N	I	10	NC	-
11	PWRSW-S3N	I	12	NC	-
13	GND	-			
1T	GND	-	2T	GND	-

C.12 CN4100 LAN interface connector (12-pin)*Table C-12 LAN interface connector (12-pin)*

Pin No.	Signal Name	I/O	Pin No.	Signal Name	I/O
1	ZMDI2P-EYP	I/O	2	ZMDI2P-EYN	I/O
3	ZMDI3P-EYP	I/O	4	ZMDI3P-EYN	I/O
5	ZMDI0P-EYP	I/O	6	ZMDI0P-EYN	I/O
7	ZMDI1P-EYP	I/O	8	ZMDI1P-EYN	I/O
9	NC	-	10	NC	-
11	LLINK-E3N	O	12	LACT-E3N	O
1T	GND	-	2T	GND	-

C.13 CN3490 LPC debug port interface connector (12-pin)*Table C-13 LPC debug port interface connector (12-pin)*

Pin No.	Signal Name	I/O	Pin No.	Signal Name	I/O
1	GND	-	2	P3V	-
3	LPCFRM		4	DBGDET-P3N	I
5	LAD0-P3P	I/O	6	LAD1-P3P	I/O
7	LAD2-P3P	I/O	8	LAD3-P3P	I/O
9	PLTRS2-E3N		10	X33DBG-P3P	
11	P3V	-	12	GND	-

C.14 CN4200 IEEE 1394 interface connector (4-pin)*Table C-14 IEEE 1394 interface connector (4-pin)*

Pin No.	Signal Name	I/O	Pin No.	Signal Name	I/O
1	ZTPB0-P3N	I/O	2	ZTPB0-P3P	I/O
3	ZTPA0-P3N	I/O	4	ZTPA0-P3P	I/O
1T	GND	-	2T	GND	-
2T	GND	-	4T	GND	-

C.15 CN4400 Bluetooth interface connector (20-pin)*Table C-15 Bluetooth interface connector (20-pin)*

Pin No.	Signal Name	I/O	Pin No.	Signal Name	I/O
1	GND	-	2	NC	-
3	BTMDL-P3N	I	4	NC	-
5	NC	-	6	NC	-
7	NC	-	8	BTRST-S3N	O
9	NC	-	10	NC	-
11	GND	-	12	NC	-
13	(GND)	-	14	WCHCLK-P3P	O
15	NC	-	16	ZUSBBT-P3P	I/O
17	ZUSBBT-E3N	I/O	18	NC	-
19	NC	-	20	BT-P3V	-
1T	GND	-	2T	GND	-

C.16 CN4614 USB 6/4 connector (8-pin)*Table C-16 USB 6/4 connector (8-pin)*

Pin No.	Signal Name	I/O	Pin No.	Signal Name	I/O
1	USBOPS-E5V	-	2	ZUSBP6-E3N	I/O
3	ZUSBP6-E3N	I/O	4	GND	-
5	USBOPS-E5V	-	6	ZUSBP4-E3N	I/O
7	ZUSBP4-E3P	I/O	8	GND	-
1T	GND	-	2T	GND	-

C.17 CN4614 USB 0 connector (4-pin)*Table C-17 USB 0 connector (4-pin)*

Pin No.	Signal Name	I/O	Pin No.	Signal Name	I/O
1	USB1PS-E5V	-	2	ZUSBP0-E3N	I/O
3	USBP0-E3P	I/O	4	GND	-
1T	GND	-	2T	GND	-

C.18 CN5000 LCD interface connector (40-pin)*Table C-18 LCD interface connector (40-pin)*

Pin No.	Signal Name	I/O	Pin No.	Signal Name	I/O
1	BRT2DA-S3P	O	2	BRT10-P5P	O
3	Pulled up to FL-P5V	O	4	FL-P5V	-
5	FL-P5V	-	6	FL-P5V	-
7	NC	-	8	GND	-
9	GND	-	10	GND	-
11	P3V	-	12	PNL-P3V	-
13	PNL-P3V	-	14	ILDSDA-P3P	I/O
15	ILDSCS-P3P	I/O	16	GND	-
17	NC	-	18	NC	-
19	GND	-	20	NC	-
21	NC	-	22	GND	-
23	NC	-	24	NC	-
25	GND	-	26	NC	-
27	NC	-	28	GND	-
29	ZTXDA2-PYN	O	30	ZTXDTA2-PYN	O
31	GND	-	32	ZTXDTA1-PYN	O
33	ZTXDTA1-PYN	O	34	GND	-
35	ZTXDTA0-PYN	O	36	ZTXDTA0-PYN	O
37	GND	-	38	XTXCKA-PYN	O
39	XTXCKA-PYN	O	40	GND	-
1T	GND	-	2T	GND	-
3T	GND	-	4T	GND	-
5T	GND	-	6T	GND	-

C.19 CN5080 RGB connector (15-pin)*Table C-19 RGB connector (15-pin)*

Pin No.	Signal Name	I/O	Pin No.	Signal Name	I/O
1	RED-PXP	O	2	GRN-PXP	O
3	BLU-PXP	O	4	NC	-
5	GND	-	6	GND	-
7	GND	-	8	GND	-
9	P5V	-	10	GND	-
11	NC	-	12	IDSDA-P3P	I/O
13	CRTEN-P3N + IHSYNC-P2P	O	14	(IVSYNC-P2P)	O
15	IDSCL-P5P	I/O			
1T	GND	-	2T	GND	-

C.20 CN6050 Internal microphone connector (2-pin)*Table C-20 Internal microphone connector (2-pin)*

Pin No.	Signal Name	I/O	Pin No.	Signal Name	I/O
1	MICIN	I	2	A-GND	-

C.21 J6051 External microphone connector (5-pin)*Table C-21 External Microphone connector (5-pin)*

Pin No.	Signal Name	I/O	Pin No.	Signal Name	I/O
1	A-GND	-	2	MICIN	I
3	VREF1	-	4	(MICIN)	I
5	NC	-			

C.22 CN6170 Speaker connector (4-pin)*Table C-22 Speaker connector (4-pin)*

Pin No.	Signal Name	I/O	Pin No.	Signal Name	I/O
1	SPOTR-PXN	O	2	SPOTR-PXP	O
3	SPOTL-PXP	-	4	SPOTL-PXN	O

C.23 J6310 Headphone connector (5-pin)*Table C-23 Headphone connector (5-pin)*

Pin No.	Signal Name	I/O	Pin No.	Signal Name	I/O
1	A-GND	-	2	HEADL-PXP	O
3	HEADR-PXP	O	4	NC	-
5	(SPKEN)	O			

C.24 CN8800 DC-IN connector (4-pin)*Table C-24 DC-IN connector (4-pin)*

Pin No.	Signal Name	I/O	Pin No.	Signal Name	I/O
1	ADPDC	-	2	ADPDC	-
3	GND	-	4	GND	-

C.25 CN8810 Main Battery connector (10-pin)*Table C-25 Main Battery connector (10-pin)*

Pin No.	Signal Name	I/O	Pin No.	Signal Name	I/O
1	PVBL1	-	2	BTMP1	I
3	(DCHG)	-	4	M5V	-
5	PSCL-S5P	I/O	6	PSDA-S5P	I/O
7	GND	-	8	DBT10V-S5N	O
9	GND	-	10	GND	-

C.26 CN9300 RTC Battery connector (3-pin)*Table C-26 RTC Battery connector (3-pin)*

Pin No.	Signal Name	I/O	Pin No.	Signal Name	I/O
1	ZS-PWCHKF	O	2	NC	-
3	GND	-			
1T	GND	-	2T	GND	-

C.27 CN8771 FAN interface connector (4-pin)*Table C-27 FAN interface connector (4-pin)*

Pin No.	Signal Name	I/O	Pin No.	Signal Name	I/O
1	P5V	-	2	FANG-P3P	I
3	GND	-	4	(FPWM-S3P)	O

C.28 CN9520 Fingerprint sensor board interface connector (6-pin)*Table C-28 OF board interface connector (6-pin)*

Pin No.	Signal Name	I/O	Pin No.	Signal Name	I/O
1	GND	-	2	ZUSBFS-E3P	I/O
3	ZUSBFS-E3N	I/O	4	GND	-
5	FGSPON-S3N	O	6	E3V	-
1T	GND	-	2T	GND	-

Fingerprint Sensor Board

C.29 CN9550 System board interface connector (6-pin)

Table C-29 System board interface connector (6-pin)

Pin No.	Signal Name	I/O	Pin No.	Signal Name	I/O
1	E3V	-	2	FGSPON-S3N	I
3	GND	-	4	ZUSBFS-E3N	I/O
5	ZUSBFS-E3P	I/O	6	GND	-
1T	GND	-	2T	GND	-

Appendix D Keyboard Scan/Character Codes

Table D-1 Scan codes (set 1 and set 2) (1/4)

Cap No.	Keytop	Code set 1		Code set 2			Note
		Make	Break	Make	Break		
01	' ~	29	A9	0E	F0	0E	
02	1 !	02	82	16	F0	16	
03	2 @	03	83	1E	F0	1E	
04	3 #	04	84	26	F0	26	
05	4 \$	05	85	25	F0	25	
06	5 %	06	86	2E	F0	2E	
07	6 ^	07	87	36	F0	36	
08	7 &	08	88	3D	F0	3D	*1
09	8 *	09	89	3E	F0	3E	*1
10	9 (0A	8A	46	F0	46	*1
11	0)	0B	8B	45	F0	45	*1
12	- _	0C	8C	4E	F0	4E	
13	= +	0D	8D	55	F0	55	
15	BkSp	0E	8E	66	F0	66	
16	Tab	0F	8F	0D	F0	0D	
17	Q	10	90	15	F0	15	
18	W	11	91	1D	F0	1D	
19	E	12	92	24	F0	24	
20	R	13	93	2D	F0	2D	
21	T	14	94	2C	F0	2C	
22	Y	15	95	35	F0	35	
23	U	16	96	3C	F0	3C	*1
24	I	17	97	43	F0	43	*1
25	O	13	98	44	F0	44	*1
26	P	19	99	4D	F0	4D	*1
27	[{	1A	9A	54	F0	54	
28] }	1B	9B	5B	F0	5B	

Table D-1 Scan codes (set 1 and set 2) (2/4)

Cap No.	Keytop	Code set 1		Code set 2		Note	
		Make	Break	Make	Break		
29	\	2B	AB	5D	F0	5D	*2
30	Caps Lock	3A	BA	58	F0	58	
31	A	1E	9E	1C	F0	1C	
32	S	1F	9F	1B	F0	1B	
33	D	20	A0	23	F0	23	
34	F	21	A1	2B	F0	2B	
35	G	22	A2	34	F0	34	
36	H	23	A3	33	F0	33	
37	J	24	A4	3B	F0	3B	*1
38	K	25	A5	42	F0	42	*1
39	L	26	A6	4B	F0	4B	*1
40	; :	27	A7	4C	F0	4C	*1
41	' "	28	A8	52	F0	52	
43	Enter	1C	9C	5A	F0	5A	*3
44	Shift (L)	2A	AA	12	F0	12	
45	No.102 key	56	D6	61	F0	61	
46	Z	2C	AC	1A	F0	1A	
47	X	2D	AD	22	F0	22	
48	C	2E	AE	21	F0	21	
49	V	2F	AF	2A	F0	2A	
50	B	30	B0	32	F0	32	
51	N	31	B1	31	F0	31	
52	M	32	B2	3A	F0	3A	*1
53	, <	33	B3	41	F0	41	*1
54	. >	34	B4	49	F0	49	*1
55	/ ?	35	B5	4A	F0	4A	*1
57	Shift (R)	36	B6	59	F0	59	

Table D-1 Scan codes (set 1 and set 2) (3/4)

Cap No.	Keytop	Code set 1		Code set 2		Note	
		Make	Break	Make	Break		
58	Ctrl	1D	9D	14	F0	14	*3
60	Alt (L)	38	B8	11	F0	11	*3
61	Space	39	B9	29	F0	29	
62	ALT (R)	E0 38	E0 B8	E0 11	E0 F0	11	
75	Ins	E0 52	E0 D2	E0 70	E0 F0	70	*4
76	Del	E0 53	E0 D3	E0 71	E0 F0	71	*4
79	←	E0 4B	E0 CB	E0 6B	E0 F0	6B	*4
80	Home	E0 47	E0 C7	E0 6C	E0 F0	6C	*4
81	End	E0 4F	E0 CF	E0 69	E0 F0	69	*4
83	↑	E0 48	E0 C8	E0 75	E0 F0	75	*4
84	↓	E0 50	E0 D0	E0 72	E0 F0	72	*4
85	PgUp	E0 49	E0 C9	E0 7D	E0 F0	7D	*4
86	PgDn	E0 51	E0 D1	E0 7A	E0 F0	7A	*4
89	→	E0 4D	E0 CD	E0 74	E0 F0	74	*4
110	Esc	01	81	76	F0	76	
112	F1	3B	BB	05	F0	05	
113	F2	3C	BC	06	F0	06	
114	F3	3D	BD	04	F0	04	
115	F4	3E	BE	0C	F0	0C	
116	F5	3F	BF	03	F0	03	
117	F6	40	C0	0B	F0	0B	
118	F7	41	C1	83	F0	83	
119	F8	42	C2	0A	F0	0A	
120	F9	43	C3	01	F0	01	
121	F10	44	C4	09	F0	09	*3

Table D-1 Scan codes (set 1 and set 2) (4/4)

Cap No.	Keytop	Code set 1				Code set 2				Note
		Make		Break		Make		Break		
122	F11	57		D7		78		F0	78	*3
123	F12	58		D8		07		F0	07	*3
124	PrintSc	Refer to table 2-25								
126	Pause	Refer to table 2-25								
202	Fn									*5
203	Win	E0	5B	E0	DB	E0	1F	E0	F0	1F
204	App	E0	5D	E0	DD	E0	2F	E0	F0	2F

Notes:

1. * Scan codes differ by overlay function.
2. * This key corresponds to key No. 42 in the 102 key mode.
3. * Combination with the **Fn** key makes different codes.
4. * Scan codes differ by mode.
5. * The Fn key does not generate a code by itself..

Table D-2 Scan codes with left Shift key

Cap No.	Key top	Code set 1		Code set 2			
		Make	Break	Make		Break	
55	/	E0 AA E0 35	E0 B5 E0 2A	E0 F0 12 E0 4A	E0 F0 4A E0 12		
75	INS	E0 AA E0 52	E0 D2 E0 2A	E0 F0 12 E0 70	E0 F0 70 E0 12		
76	DEL	E0 AA E0 53	E0 D3 E0 2A	E0 F0 12 E0 71	E0 F0 71 E0 12		
79	←	E0 AA E0 4B	E0 CB E0 2A	E0 F0 12 E0 6B	E0 F0 6B E0 12		
80	Home	E0 AA E0 47	E0 C7 E0 2A	E0 F0 12 E0 6C	E0 F0 6C E0 12		
81	End	E0 AA E0 4F	E0 CF E0 2A	E0 F0 12 E0 69	E0 F0 69 E0 12		
83	↑	E0 AA E0 48	E0 C8 E0 2A	E0 F0 12 E0 75	E0 F0 75 E0 12		
84	↓	E0 AA E0 50	E0 D0 E0 2A	E0 F0 12 E0 72	E0 F0 72 E0 12		
85	PgUp	E0 AA E0 49	E0 C9 E0 2A	E0 F0 12 E0 7D	E0 F0 7D E0 12		
86	PgDn	E0 AA E0 51	E0 D1 E0 2A	E0 F0 12 E0 7A	E0 F0 7A E0 12		
89	→	E0 AA E0 4D	E0 CD E0 2A	E0 F0 12 E0 74	E0 F0 74 E0 12		
203	Win	E0 AA E0 5B	E0 DB E0 2A	E0 F0 12 E0 1F	E0 F0 1F E0 12		
204	App	E0 AA E0 5D	E0 DD E0 2A	E0 F0 12 E0 2F	E0 F0 2F E0 12		

Note : The table above shows scan codes with the left **Shift** key.
In the case of Key no. 55 Overlay mode only.

In combination with the right **Shift** key, scan codes are changed as listed below:

	With left Shift	With right Shift
Set 1	E0 AA _____	E0 B6
	E0 2A _____	E0 36
Set 2	E0 F0 12 _____	E0 F0 59
	E0 12 _____	E0 59

Table D-3 Scan codes in Numlock mode

Cap No.	Key top	Code set 1		Code set 2			
		Make	Break	Make	Break		
75	INS	E0 2A E0 52	E0 D2 E0 AA	E0 12 E0 70	E0 F0 70	E0 F0 12	
76	DEL	E0 2A E0 53	E0 D3 E0 AA	E0 12 E0 71	E0 F0 71	E0 F0 12	
79	←	E0 2A E0 4B	E0 CB E0 AA	E0 12 E0 6B	E0 F0 6B	E0 F0 12	
80	Home	E0 2A E0 47	E0 C7 E0 AA	E0 12 E0 6C	E0 F0 6C	E0 F0 12	
81	End	E0 2A E0 4F	E0 CF E0 AA	E0 12 E0 69	E0 F0 69	E0 F0 12	
83	↑	E0 2A E0 48	E0 C8 E0 AA	E0 12 E0 75	E0 F0 75	E0 F0 12	
84	↓	E0 2A E0 50	E0 D0 E0 AA	E0 12 E0 72	E0 F0 72	E0 F0 12	
85	PgUp	E0 2A E0 49	E0 C9 E0 AA	E0 12 E0 7D	E0 F0 7D	E0 F0 12	
86	PgDn	E0 2A E0 51	E0 D1 E0 AA	E0 12 E0 7A	E0 F0 7A	E0 F0 12	
89	→	E0 2A E0 4D	E0 CD E0 AA	E0 12 E0 74	E0 F0 74	E0 F0 12	
203	Win	E0 2A E0 5B	E0 DB E0 AA	E0 12 E0 1F	E0 F0 1F	E0 F0 12	
204	App	E0 2A E0 5D	E0 DD E0 AA	E0 12 E0 2F	E0 F0 2F	E0 F0 12	

Table D-4 Scan codes with Fn key

Cap No.	Key top	Code set 1		Code set 2		
		Make	Break	Make	Break	
43	ENT	E0 1C	E0 9C	E0 5A	E0 F0 5A	
58	CTRL	E0 1D	E0 9D	E0 14	E0 F0 14	
60	LALT	E0 38	E0 B8	E0 11	E0 F0 11	
121	ARROW	45	C5	77	F0 77	
122	NUMERIC	45	C5	77	F0 77	
123	Scrl	46	C5	7E	F0 7E	

Table D-5 Scan codes in overlay mode

Cap No.	Keytop		Code set 1		Code set 2		
			Make	Break	Make	Break	
09	8	(8)	48	C8	75	F0	75
10	9	(9)	49	C9	7D	F0	7D
11	0	(*)	37	B7	7C	F0	7C
23	U	(4)	4B	CB	6B	F0	6B
24	I	(5)	4C	CC	73	F0	73
25	O	(6)	4D	CD	74	F0	74
26	P	(-)	4A	CA	7B	F0	7B
37	J	(1)	4F	CF	69	F0	69
38	K	(2)	50	D0	72	F0	72
39	L	(3)	51	D1	7A	F0	7A
40	;	(+)	4E	CE	79	F0	79
52	M	(0)	52	D2	70	F0	70
54	.	(.)	53	D3	71	F0	71
55	/	(/)	E0 35	E0 B5	40 4A	E0 F0	4A

Table D-6 No.124 key scan code

Key top	Shift	Code set 1				Code set 2			
		Make		Break		Make		Break	
Prt Sc	Common	E0 2A	E0 37	E0 B7	E0 AA	E0 12	E0 7C	E0 F0	7C E0 F0 12
	Ctrl +	E0 37		E0 B7		E0 7C		E0 F0	7C
	Shift +	E0 37		E0 B7		E0 7C		E0 F0	7C
	Alt +		54	D4		84		F0 B4	

Table D-7 No.126 key scan code

Key top	Shift	Code set 1						Code set 2							
		Make						Make							
Pause	Common *	E1	1D	45	E1	9D	C5	E1	14	77	E1	F0	14	F0	77
	Ctrl*	E0	46	E0	C6			E0	7E	E0	F0	7E			

*: This key generates only make codes.

Appendix E Key Layout

E.1 United Kingdom (UK) Keyboard

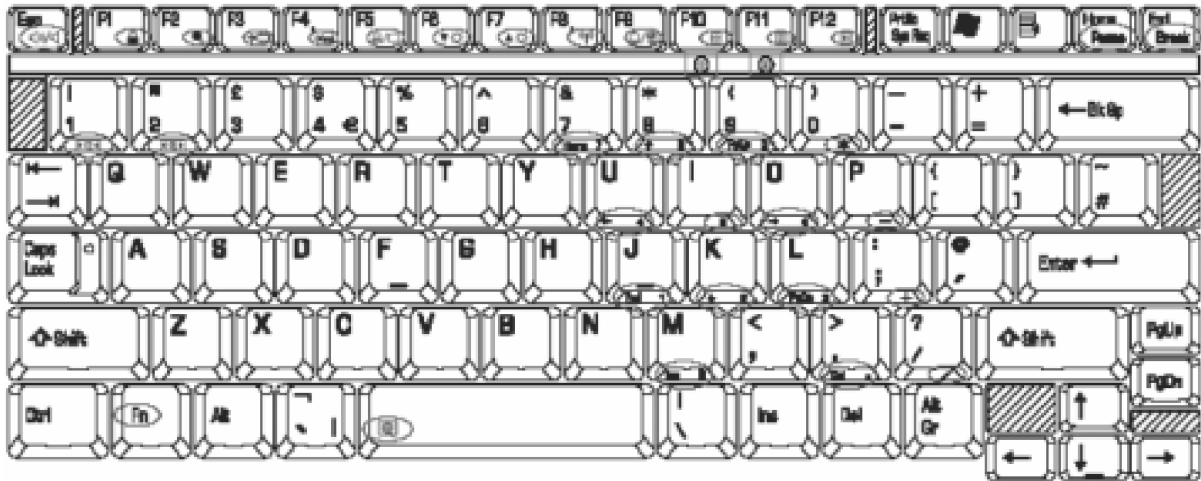

Figure E-1 UK keyboard

E.2 United States (US) Keyboard

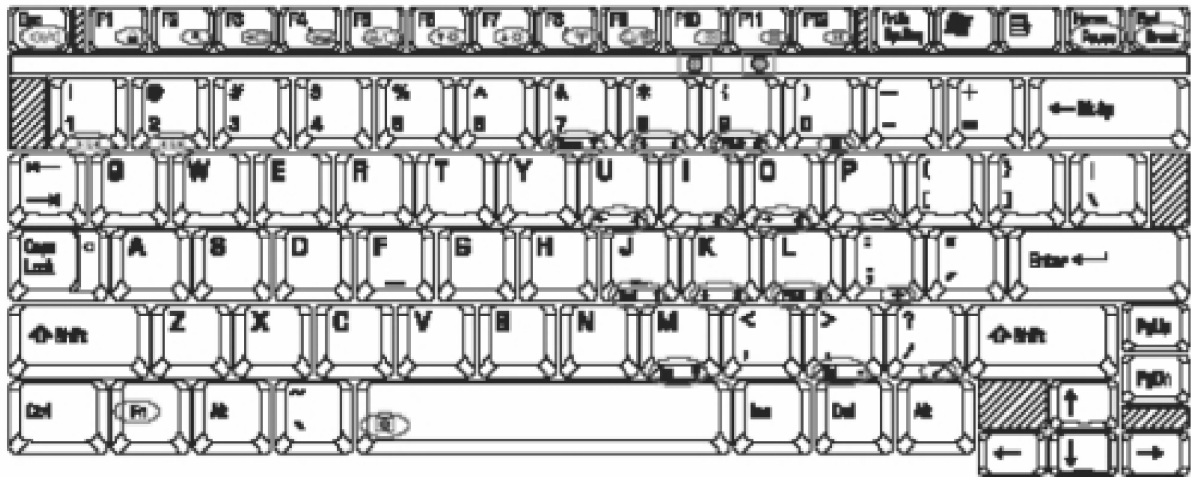

Figure E-2 US keyboard

Appendix F Wiring diagrams

F.1 LAN Loopback Connector

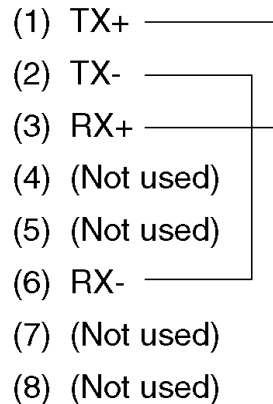

Figure F-1 LAN Loopback Connector

F.2 RGB Monitor Loopback Connector

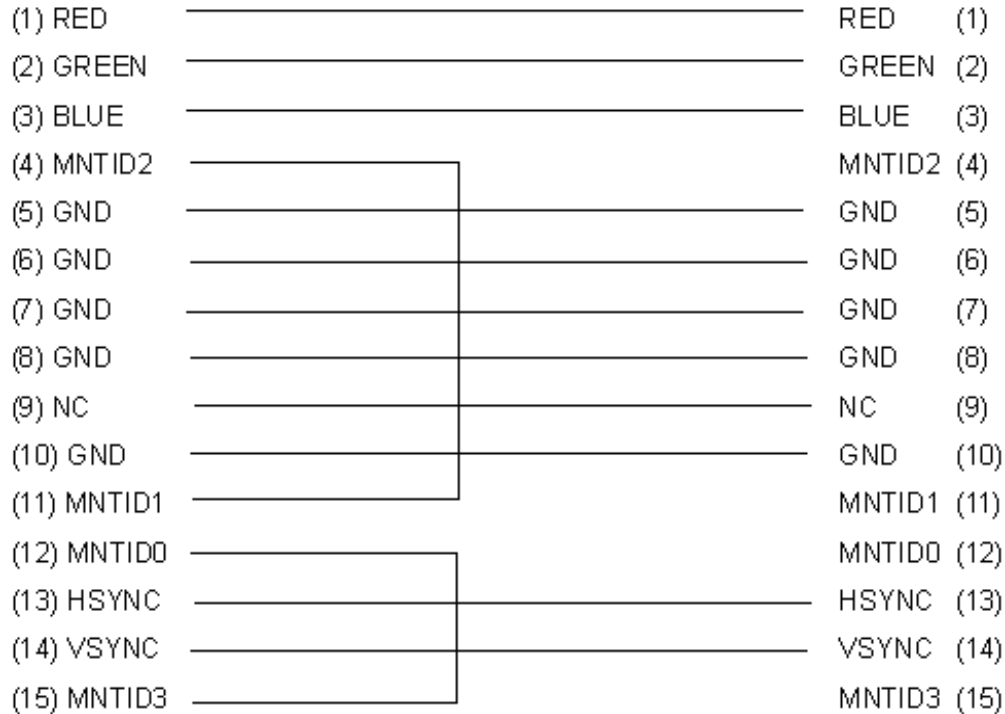

Figure F-2 RGB Monitor Loopback Connector

Appendix G BIOS rewrite procedures

This Appendix explains how to rewrite the system BIOS program when you update the system BIOS.

Tools

To rewrite the BIOS, you need the following tool:

- BIOS/EC/KBC rewriting disk for the computer that has renewed BIOS data.

Rewriting the BIOS

1. Set the system to boot mode.
2. Turn off the power to the computer.
3. Remove the external cable and PC card.
4. Connect an USB FDD and insert the BIOS/EC/KBC rewriting disk into the USB FDD.
5. Turn on the power while holding down the tilde character key until a beep sounds.

For example



(US Keyboard)



(UK Keyboard)

(There is the key at the left side of the **1** key in the UK key board.)

6. The BIOS rewriting starts
7. When the process is completed, it beeps and the system automatically reboots.

NOTE:

1. Connect the AC adapter to the computer when you rewrite the BIOS.
2. Do not turn off the power while you are rewriting the BIOS. If the rewrite fails, it might be impossible to start up the computer.
3. If you fail to rewrite BIOS, then when you next turn on the power, a message may be displayed that the contents of the BIOS have been erased. In this case, insert the BIOS rewriting disk and the BIOS will be rewritten.

Appendix H EC/KBC rewrite procedures

This Appendix explains how to rewrite the EC/KBC system program when you update the EC/KBC system.

Tools

To rewrite the EC/KBC, you need the following tool:

- ❑ EC/KBC rewriting disk for the computer

Rewriting the EC/KBC

- NOTE:**
1. Rewrite the EC/KBC only when instructed by a diagnostic disk release notice.
 2. Connect the AC adaptor to the computer when you rewrite the EC/KBC.
 3. Do not turn off the power while you are rewriting the EC/KBC. If the rewrite fails, it might be impossible to start up the computer.
 4. If you fail to rewrite EC/KBC, then when you next turn on the power, a message may be displayed that the contents of the EC/KBC have been erased. In this case, insert the BIOS/EC/KBC rewriting disk and the EC/KBC will be rewritten.
 5. Normally it takes about 30 seconds to rewrite the EC/KBC. It may take 3 minutes (maximum), depending on the conditions of the computer or ICs. The computer is not hung up. Allow sufficient time. Never reboot or turn off the power to the computer before the rewriting is completed.

1. Set the system to boot mode.
2. Turn off the power to the computer.
3. Remove the external cable and PC Card.
4. Connect an USB FDD and insert the BIOS/EC/KBC rewriting disk into the USB FDD.
5. Turn on the power while holding down the **Tab** key. (Keep holding down the key until a beep sounds.) The EC/KBC rewriting starts.
6. When the EC/KBC rewrite is completed, the system is automatically turned off.

Appendix I Reliability

The following table shows MTBF (Mean Time Between Failures).

Table I-1 MTBF

	Time (hours)
MTBF	6,056

Free Manuals Download Website

<http://myh66.com>

<http://usermanuals.us>

<http://www.somanuals.com>

<http://www.4manuals.cc>

<http://www.manual-lib.com>

<http://www.404manual.com>

<http://www.luxmanual.com>

<http://aubethermostatmanual.com>

Golf course search by state

<http://golfingnear.com>

Email search by domain

<http://emailbydomain.com>

Auto manuals search

<http://auto.somanuals.com>

TV manuals search

<http://tv.somanuals.com>