

**TEC**

TEC Thermal Printer

# **B-480-QQ SERIES**

## **Owner's Manual**

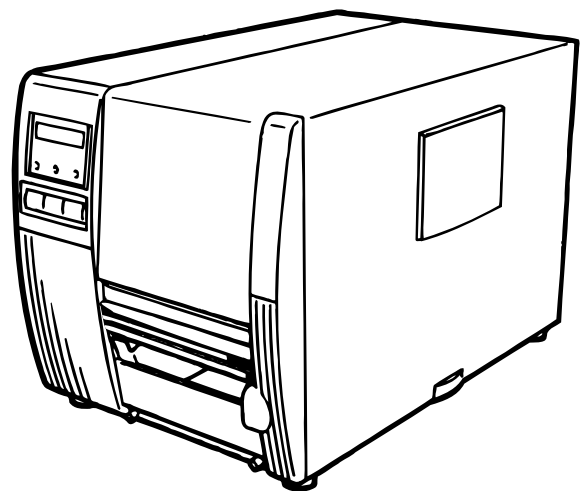

**TOSHIBA TEC CORPORATION**

This equipment has been tested and found to comply with the limits for a Class A digital device, pursuant to Part 15 of the FCC Rules. These limits are designed to provide reasonable protection against harmful interference when the equipment is operated in a commercial environment. This equipment generates, uses, and can radiate radio frequency energy and, if not installed and used in accordance with the instruction manual, may cause harmful interference to radio communications. Operations of this equipment in a residential area is likely to cause harmful interference in which case the user will be required to correct the interference at his own expense.

(for USA only)

Changes or modifications not expressly approved by manufacturer for compliance could void the user's authority to operate the equipment.

"This Class A digital apparatus meets all requirements of the Canadian Interference-Causing Equipment Regulations."

"Cet appareil numérique de la classe A respecte toutes les exigences du Règlement sur le matériel brouilleur du Canada."

(for CANADA only)

**CAUTION**

*To avoid injury, be careful not to catch or jam your fingers while opening or closing the cover.*

**CAUTION**

*Do not touch moving parts. To reduce the risk that fingers, jewelry, clothing, etc., be drawn into the moving parts, push the switch in the "OFF" position to stop movement.*

As an ENERGY STAR® Partner, TOSHIBA TEC has determined that this product meets the ENERGY STAR® guidelines for energy efficiency.



-- Outline of the International ENERGY STAR® Office Equipment Program --

The International ENERGY STAR® Office Equipment Program is an international program that promotes energy saving through the penetration of energy efficient computers and other office equipment. The program backs the development and dissemination of products with functions that effectively reduce energy consumption. It is an open system in which business proprietors can participate voluntarily. The targeted products are office equipment such as computers, monitors, printers, facsimiles, copiers, scanners, and multifunction devices. Their standards and logos are uniform among participating nations.

ENERGY STAR is a U.S. registered mark.

Copyright © 2002  
by TOSHIBA TEC CORPORATION  
All Rights Reserved  
570 Ohito, Ohito-cho, Tagata-gun, Shizuoka-ken, JAPAN

## Safety Summary

Personal safety in handling or maintaining the equipment is extremely important. Warnings and Cautions necessary for safe handling are included in this manual. All warnings and cautions contained in this manual should be read and understood before handling or maintaining the equipment. Do not attempt to effect repairs or modifications to this equipment. If a fault occurs that cannot be rectified using the procedures described in this manual, turn off the power, unplug the machine, then contact your authorized TOSHIBA TEC representative for assistance.

### Meanings of Each Symbol



This symbol indicates warning items (including cautions). Specific warning contents are drawn inside the  $\triangle$  symbol. (The symbol on the left indicates a general caution.)



This symbol indicates prohibited actions (prohibited items). Specific prohibited contents are drawn inside or near the  $\circ$  symbol. (The symbol on the left indicates "no disassembling".)



This symbol indicates actions which must be performed. Specific instructions are drawn inside or near the  $\bullet$  symbol. (The symbol on the left indicates "disconnect the power cord plug from the outlet".)



## WARNING

This indicates that there is the risk of **death** or **serious injury** if the machines are improperly handled contrary to this indication.



Any other than the specified AC voltage is prohibited.

■ Do not use voltages other than the voltage (AC) specified on the rating plate, as this may cause **fire** or **electric shock**.

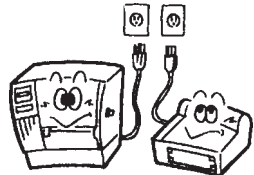

**Prohibited**

■ Do not plug in or unplug the power cord plug with wet hands as this may cause **electric shock**.

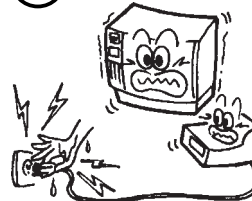

**Prohibited**

■ If the machines share the same outlet with any other electrical appliances which consume large amounts of power, the voltage will fluctuate widely each time these appliances operate. Be sure to provide an exclusive outlet for the machine as this may cause the machines to **malfunction**.



**Prohibited**

■ Do not place metal objects or water-filled containers such as flower vases, flower pots or mugs, etc. on top of the machines. If metal objects or spilled liquid enter the machines, this may cause **fire** or **electric shock**.

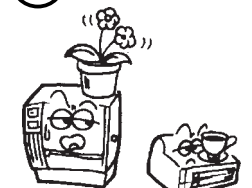

**Prohibited**

■ Do not insert or drop metal, flammable or other foreign objects into the machines through the ventilation slits, as this may cause **fire** or **electric shock**.

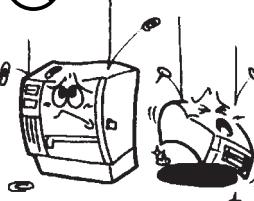

**Prohibited**

■ Do not scratch, damage or modify the power cords. Also, do not place heavy objects on, pull on, or excessively bend the cords, as this may cause **fire** or **electrical shock**.

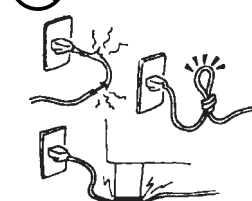

**Disconnect the plug.**



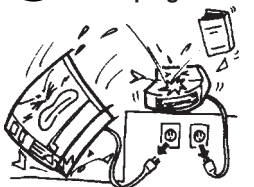



■ If the machines are dropped or their cabinets damaged, first turn off the power switches and disconnect the power cord plugs from the outlet, and then contact your authorized TOSHIBA TEC representative for assistance. Continued use of the machine in that condition may cause **fire** or **electric shock**.

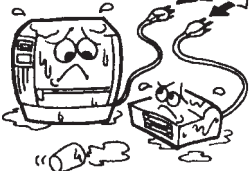

**Disconnect the plug.**

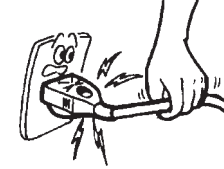
■ Continued use of the machines in an abnormal condition such as when the machines are producing smoke or strange smells may cause **fire** or **electric shock**. In these cases, immediately turn off the power switches and disconnect the power cord plugs from the outlet. Then, contact your authorized TOSHIBA TEC representative for assistance.

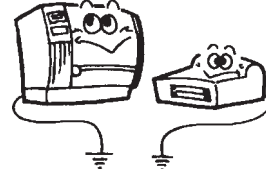

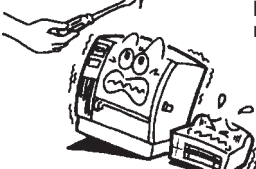
 <p><b>Disconnect the plug.</b></p>  <p>■ If foreign objects (metal fragments, water, liquids) enter the machines, first turn off the power switches and disconnect the power cord plugs from the outlet, and then contact your authorized TOSHIBA TEC representative for assistance. Continued use of the machine in that condition may cause <b>fire</b> or <b>electric shock</b>.</p>	 <p><b>Disconnect the plug.</b></p>  <p>■ When unplugging the power cords, be sure to hold and pull on the plug portion. Pulling on the cord portion may cut or expose the internal wires and cause <b>fire</b> or <b>electric shock</b>.</p>
 <p><b>Connect a grounding wire.</b></p>  <p>■ Ensure that the equipment is properly grounded. Extension cables should also be grounded. <b>Fire</b> or <b>electric shock</b> could occur on improperly grounded equipment.</p>	 <p><b>No disassembling.</b></p>  <p>■ Do not remove covers, repair or modify the machine by yourself. You may be <b>injured</b> by high voltage, very hot parts or sharp edges inside the machine.</p>



**CAUTION** This indicates that there is the risk of personal **Injury** or **damage** to objects if the machines are improperly handled contrary to this indication.

**Precautions**

The following precautions will help to ensure that this machine will continue to function correctly.

- Try to avoid locations that have the following adverse conditions:
  - \* Temperatures out of the specification
  - \* Direct sunlight
  - \* High humidity
  - \* Shared power source
  - \* Excessive vibration
  - \* Dust/Gas
- The cover should be cleaned by wiping with a dry cloth or a cloth slightly dampened with a mild detergent solution. NEVER USE THINNER OR ANY OTHER VOLATILE SOLVENT on the plastic covers.
- USE ONLY TOSHIBA TEC SPECIFIED paper and ribbons.
- DO NOT STORE the paper or ribbons where they might be exposed to direct sunlight, high temperatures, high humidity, dust, or gas.
- Ensure the printer is operated on a level surface.
- Any data stored in the memory of the printer could be lost during a printer fault.
- Try to avoid using this equipment on the same power supply as high voltage equipment or equipment likely to cause mains interference.
- Unplug the machine whenever you are working inside it or cleaning it.
- Keep your work environment static free.
- Do not place heavy objects on top of the machines, as these items may become unbalanced and fall causing **injury**.
- Do not block the ventilation slits of the machines, as this will cause heat to build up inside the machines and may cause **fire**.
- Do not lean against the machine. It may fall on you and could cause **injury**.
- Care must be taken not to injure yourself with the printer paper cutter.
- Unplug the machine when it is not used for a long period of time.

**Request Regarding Maintenance**

- Utilize our maintenance services.  
After purchasing the machine, contact your authorized TOSHIBA TEC representative for assistance once a year to have the inside of the machine cleaned. Otherwise, dust will build up inside the machines and may cause a **fire** or a **malfunction**. Cleaning is particularly effective before humid rainy seasons.
- Our preventive maintenance service performs the periodic checks and other work required to maintain the quality and performance of the machines, preventing accidents beforehand. For details, please consult your authorized TOSHIBA TEC representative for assistance.
- Using insecticides and other chemicals  
Do not expose the machines to insecticides or other volatile solvents. This will cause the cabinet or other parts to deteriorate or cause the paint to peel.

## TABLE OF CONTENTS

	Page
<b>1. INTRODUCTION .....</b>	<b>E1- 1</b>
1.1 Applicable Model .....	E1- 1
1.2 Accessories .....	E1- 1
<b>2. SPECIFICATIONS .....</b>	<b>E2- 1</b>
2.1 Printer .....	E2- 1
2.2 Options .....	E2- 2
2.3 Ribbon .....	E2- 2
2.4 Media .....	E2- 3
<b>3. OVERVIEW .....</b>	<b>E3- 1</b>
3.1 Front/Rear View .....	E3- 1
3.2 Operation Panel .....	E3- 1
<b>4. INSTALLING THE PRINTER .....</b>	<b>E4- 1</b>
4.1 Connecting the Power Cord and Cables .....	E4- 1
<b>5. LOADING THE MEDIA .....</b>	<b>E5- 1</b>
<b>6. LOADING THE RIBBON .....</b>	<b>E6- 1</b>
<b>7. INSERTING THE OPTIONAL PCMCIA CARD .....</b>	<b>E7- 1</b>
<b>8. CARE/HANDLING OF THE MEDIA AND RIBBON .....</b>	<b>E8- 1</b>
<b>9. GENERAL MAINTENANCE .....</b>	<b>E9- 1</b>
9.1 Cleaning .....	E9- 1
9.2 Covers and Panels .....	E9- 2
9.3 Removing Jammed Paper .....	E9- 2
9.4 Threshold Setting .....	E9- 4
<b>10. TROUBLESHOOTING .....</b>	<b>E10- 1</b>

### **CAUTION:**

1. *This manual may not be copied in whole or in part without prior written permission of TOSHIBA TEC.*
2. *The contents of this manual may be changed without notification.*
3. *Please refer to your local Authorized Service representative with regard to any queries you may have in this manual.*

# 1. INTRODUCTION

Thank you for choosing the TEC B-480 series thermal/transfer printer. This high performance printer is equipped with superior hardware including the specially developed (12 dots/mm, 304.8 dots/inch) near edge print head which will allow very clear print at a maximum speed of 203.2 mm/sec. (8 inches/sec.). The media supply is internal. Optional features include an automatic ribbon saver, a built-in rewinder/strip mechanism and external media supply.

This manual contains general set-up and maintenance information and should be read carefully to help gain maximum performance and life from your printer. For most queries please refer to this manual and keep it safe for future reference.

## 1.1 Applicable Model

- B-482-TS10-QQ

Model name description

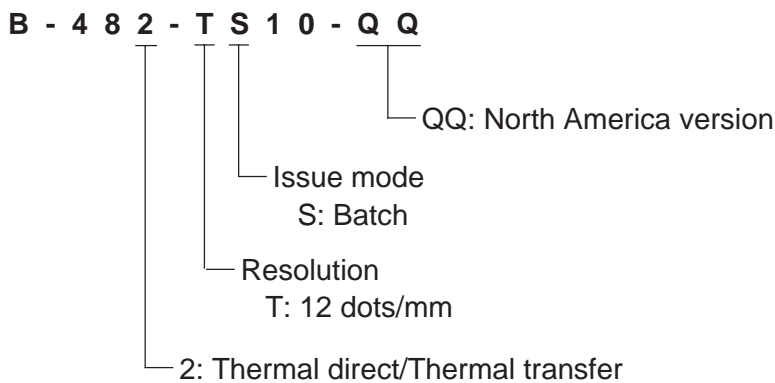

## 1.2 Accessories

Owner's Manual  
(EO1-33008)

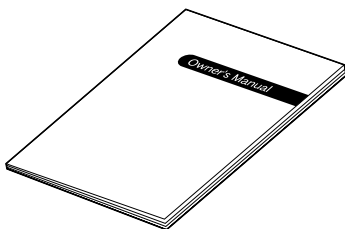

Power Cord

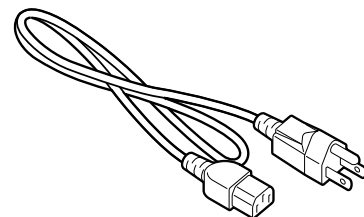

Unpacking Procedure

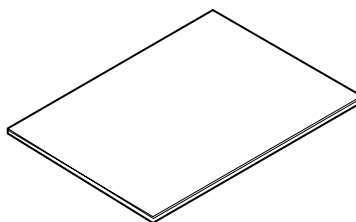

Quality control report

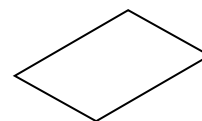

## 2. SPECIFICATIONS

### 2.1 Printer

Item	Model	B-482-TS10-QQ
Supply voltage		AC 100V ~ 120V +10%, -15%, 50Hz
Power consumption		2.51A, 150W maximum (standby: 430mA, 20W)
Operating temperature range		5°C ~ 40°C (41°F ~ 104°F)
Relative humidity		25% ~ 85%RH (no condensation)
Print head		Thermal print head 12 dots per mm (304.8 dots per inch)
Printing methods		Thermal direct or Thermal transfer
Print speeds		76.2 mm/sec. (3 inch/sec.), 127 mm/sec. (5 inch/sec.), 203.2 mm/sec. (8 inch/sec.), 101.6 mm/sec. (4inch/sec.) ... Thermal direct only
Maximum print width		104.0 mm (4.09 inches)
Dispensing modes		Batch (Continuous), Strip (On-demand) and Cut modes (Both cut and strip modes are available only when their respective modules are fitted.)
Message display		16 characters x 1 line
Dimensions		291 mm (width) x 460 mm (depth) x 308 mm (height)
Weight		17 kg (without media and ribbon)
Available bar code types		JAN8, EAN8, JAN13, EAN13, UPC-A, UPC-B EAN8, EAN13, UPC-A, UPC-E + 2digit EAN8, EAN13, UPC-A, UPC-E + 5digit NW-7 CODE39 (STANDARD) CODE39 (FULL ASCII) ITF MSI CODE93 CODE128 EAN128 Data Matrix PDF417 QR Code industrial 2 of 5 Customer Bar Code POSTNET RM4SCC (ROYAL MAIL 4STATE CUSTOMERCODE) KIX CODE Maxi Code Micro PDF417
Fonts		Times Roman (6 sizes), Helvetica (6 sizes), Presentation (1 size), Letter Gothic (1 size), Prestige Elite (2 sizes), Courier (2 sizes), OCR (2 types), Writable characters (2-byte character is available), Outline font (4 type), Price font (3 types)
Rotations		0°, 90°, 180°, 270°
Standard interface		Serial interface (RS-232C) Parallel interface (Centronics)
Optional interfaces		Expansion I/O interface PCMCIA card interface

## 2.2 Option

Option Name	Type	Usage
Swing cutter module	B-4205-QM	A stop and cut swing cutter
Rotary cutter module	B-8204-QM	Rotary cutter
Peel off module	B-4905-H-QM	This allows use of on-demand (peel-off) operation or to rewind labels and backing paper together when using the rewind guide plate. To purchase the strip module, please inquire at your local distributor.
Ribbon saving module	B-4905-R-QM	This module moves the print head up and down by using a solenoid to save the ribbon loss as far as possible. To purchase the ribbon saving module, please contact your distributor or TOSHIBA TEC HQ can assist in finding one for you.
Fanfold paper guide module	B-4905-FF-QM	This is a paper guide exclusively used for fanfold paper. Attaching it in place of the standard paper guide allows the printer to print on fanfold paper.
PCMCIA interface board	B-8700-PC-QM	This board enables the following PCMCIA cards to be used. * LAN card: 3 COM EtherLink®III (recommended) 3 COM 3CCE589ET (recommended) * ATA card: Conforming to PC card ATA standard * Flash memory card: 1MB and 4MB cards (See Page 7-1.)
Expansion I/O interface board	B-8700-IO-QM	Installing this board allows connection to external device.

**NOTE:** To purchase the *OPTIONAL KIT*, please contact your authorized *TOSHIBA TEC* representative or *TOSHIBA TEC* Head Quarter.

## 2.3 Ribbon

Type	Spool type
Width	68 mm ~ 112 mm
Length	600 m
Outer diameter	ø90 mm (max.)

- NOTES:**
1. "On the fly issue" means that the printer can draw and print without stopping between labels.
  2. To ensure print quality and print head life use only TOSHIBA TEC specified media and ribbons.
  3. When using the cutter ensure that label length  $\textcircled{B}$  plus inter label gap length  $\textcircled{E}$  exceeds 35 mm. (i.e. label pitch should be greater than 35 mm.) (See Page 2-3.)
  4. When rewinding the media onto the take-up spool in batch mode, the max. outer roll diameter should be 180 mm.
  5. Use of rough media for the ribbon saving issue may cause ribbon smudges.



2.4 Media

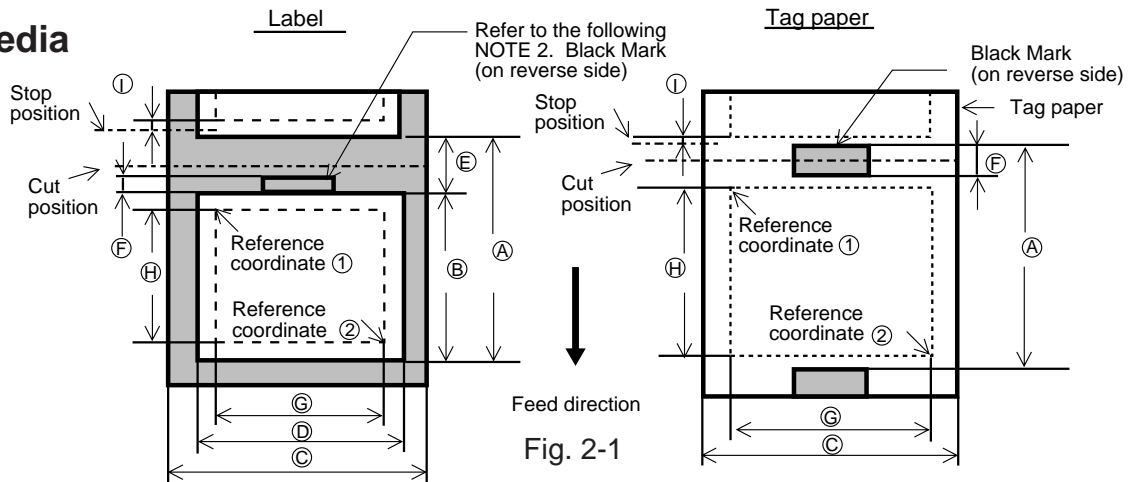

Fig. 2-1

[Unit: mm]

Label dispensing mode			Batch mode	Strip mode	Cut mode			
Item					Rotary cutter		Swing cutter	
					Head-up is OFF	Head-up is ON		
Ⓐ : Span of one label/tag	Label	Min.	10.0	25.4	3"/sec.:94.0	3"/sec.:38.0	38.0	
		Max.	2730.0					
	Tag	Min.	10.0	-	3"/sec.:30.0	4"/sec.:30.0		25.4
		Max.	2730.0	-	5"/sec.:30.0	8"/sec.:38.0		
Ⓑ : Label/tag length		Min.	8.0	23.4	3"/sec.:81.0(*1)	3"/sec.:25.0	25.0 (*5)	
		Max.	2728.0		4"/sec.:85.0(*2)	4"/sec.:25.0		
Ⓒ : Width including backing paper		Min.	50.8					
		Max.	112.0					
Ⓓ : Label width		Min.	47.8					
		Max.	109.0					
Ⓔ : Gap length		Min.	2.0		6.0			
		Max.	20.0					
Ⓕ : Black mark length (Tag paper)		Min.	2.0					
		Max.	10.0					
Ⓖ : Effective print width		Min.	10.0					
		Max.	104.0 ± 0.2					
Ⓗ : Effective print length	Label	Min.	6.0	21.4	3"/sec.:79.0	3"/sec.:23.0	23.0	
		Max.	2726.0					
	Tag	Min.	8.0	-	3"/sec.:28.0	4"/sec.:28.0		23.0
		Max.	2726.0	-	5"/sec.:28.0	8"/sec.:36.0		
Ⓘ : Print speed up/slow down area			1.0					
Thickness	Label	Min. 130 μm, Max. 170 μm						
	Tag	Min. 150 μm, Max. 290 μm						
Maximum effective length for on the fly issue			1361.0					
Outer roll diameter			ø 200 Max.					

- NOTES:**
- The media specification other than above are unchanged.
  - The label length must be satisfied by the following conditions in each case.
    - (\*1) When issuing a label using the rotary cutter, printing at a speed of 3"/sec., label length should be: 91.0mm - (Gap length/2) or more
    - (\*2) When issuing a label using the rotary cutter, printing at a speed of 4"/sec., label length should be: 95.0mm - (Gap length/2) or more
    - (\*3) When issuing a label using the rotary cutter, printing at a speed of 5"/sec., label length should be: 99.0mm - (Gap length/2) or more
    - (\*4) When issuing a label using the rotary cutter, printing at a speed of 8"/sec., label length should be: 110.0mm - (Gap length/2) or more
    - (\*5) When issuing a label using the swing cutter, label length should be: 35.0mm - (Gap length/2)

## 3. OVERVIEW

### 3.1 Front/Rear View

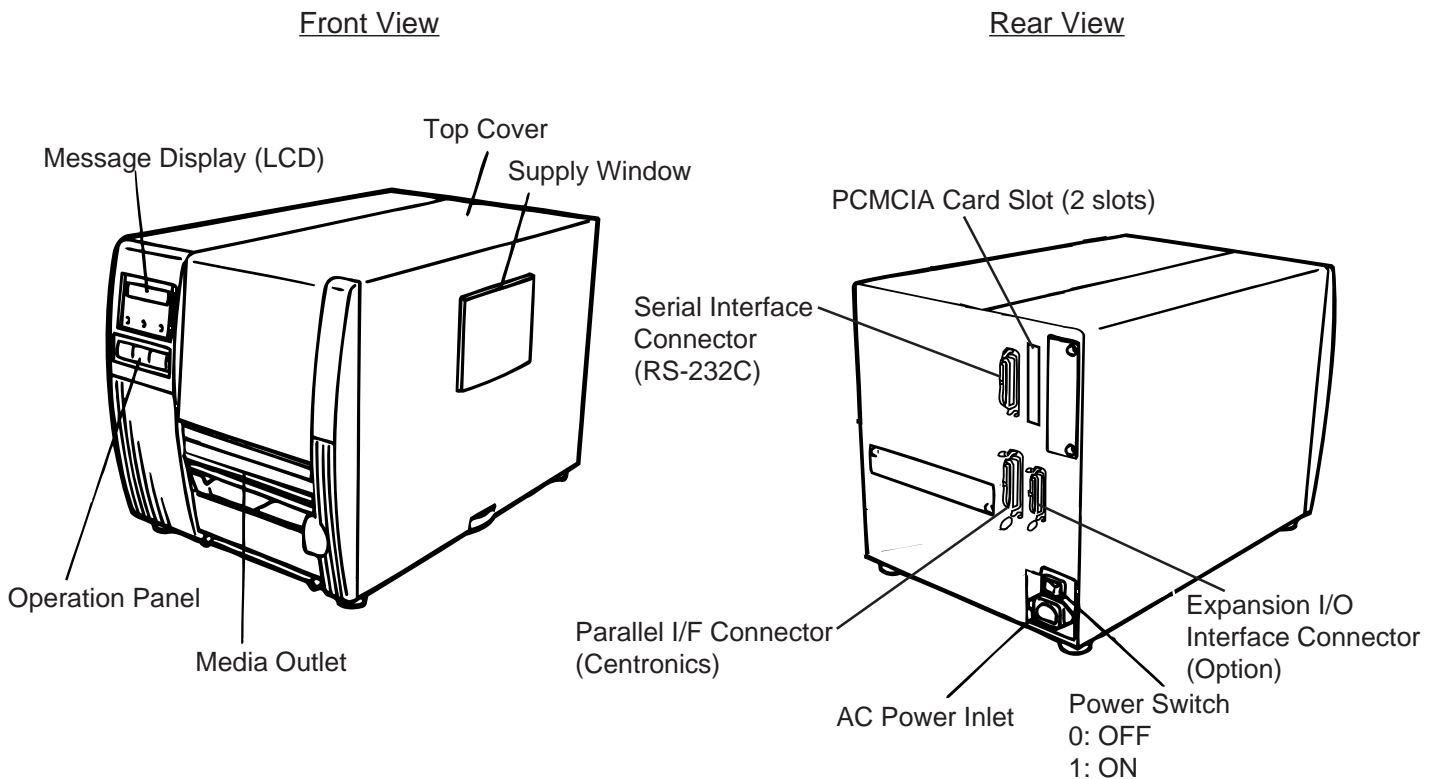

Fig. 3-1

### 3.2 Operation Panel

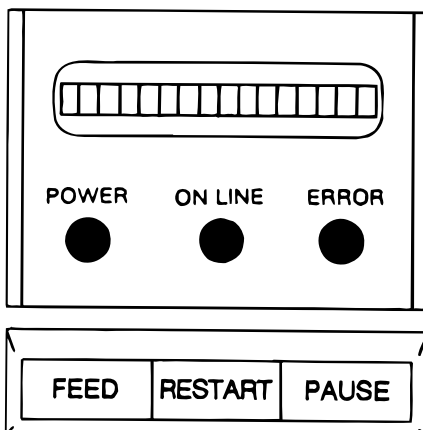

Fig. 3-2

#### MESSAGE DISPLAY (LCD)

When power is turned on and it is ready to print, "ON LINE" is displayed.

#### POWER LED (Green)

Lights when the power is turned on.

#### ON-LINE LED (Green)

- 1) Flashes when communicating with a host computer.
- 2) On while printing.

#### ERROR LED (Red)

Lights when a communication error occurs, when the media/ribbon ends or the printer does not operate correctly.

#### FEED key

Feeds paper.

#### RESTART key

Resets the printer when paused or when an error occurs. Used to set the threshold. (Refer to page 10-3)

#### PAUSE key

Pauses printing.

Message display shows "PAUSE" and an unprinted count. Used to set the threshold. (Refer to page 10-3)

## 4. INSTALLING THE PRINTER

### 4.1 Connecting the Power Cord and Cables

**WARNING:**

Turn the **POWER SWITCH** to **OFF** before connecting the power cord or cables.

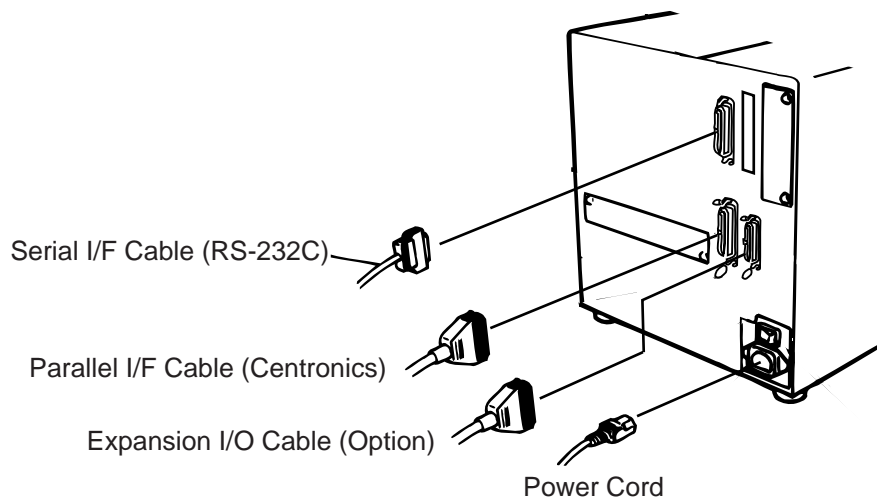

Fig. 4-1

## 5. LOADING THE MEDIA

### WARNING:

1. Do not touch moving parts. To reduce the risk that fingers, jewelry, clothing, etc., be drawn into the moving parts, push the switch in the "OFF" position to stop movement.
2. To avoid injury, be careful not to catch or jam your fingers while opening or closing the cover.

The printer prints both labels and tags.

1. Turn off the power and open the top cover.
2. Turn the head lever to position ③, then release the ribbon shaft holder plate.

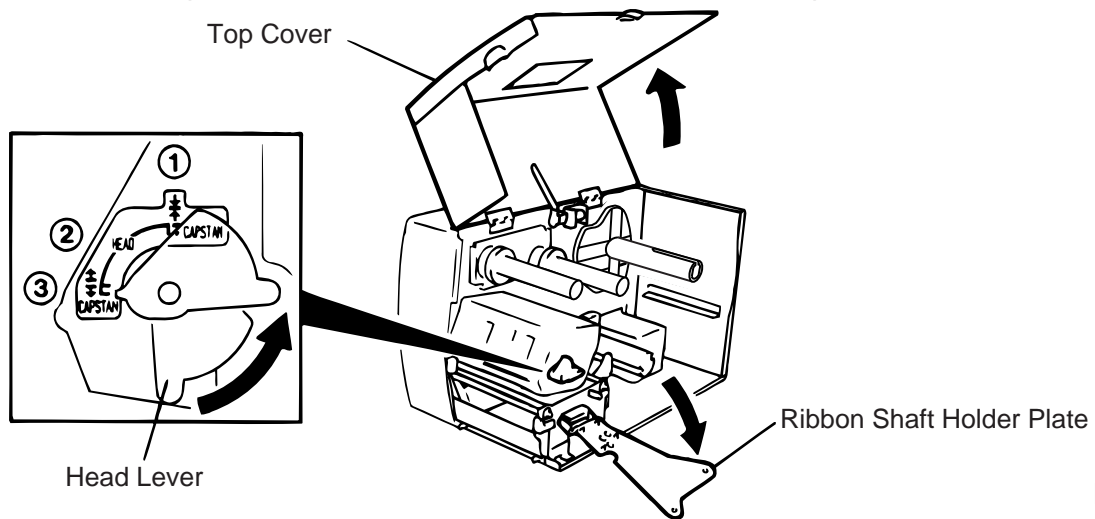

Fig. 5-1

- NOTES:**
1. When the head lever is turned to position ②, the print head is raised.
  2. When the head lever is turned to position ③, the print head and the pinch roller are raised.
  3. To allow printing the head lever must be set to position ①. (This ensures that the print head and the pinch roller are closed.)

3. Turn the locking ring counter clockwise and remove the supply holder from the supply shaft.

**NOTE:** Do not turn the force the locking ring too far counterclockwise or it may come off the supply holder.

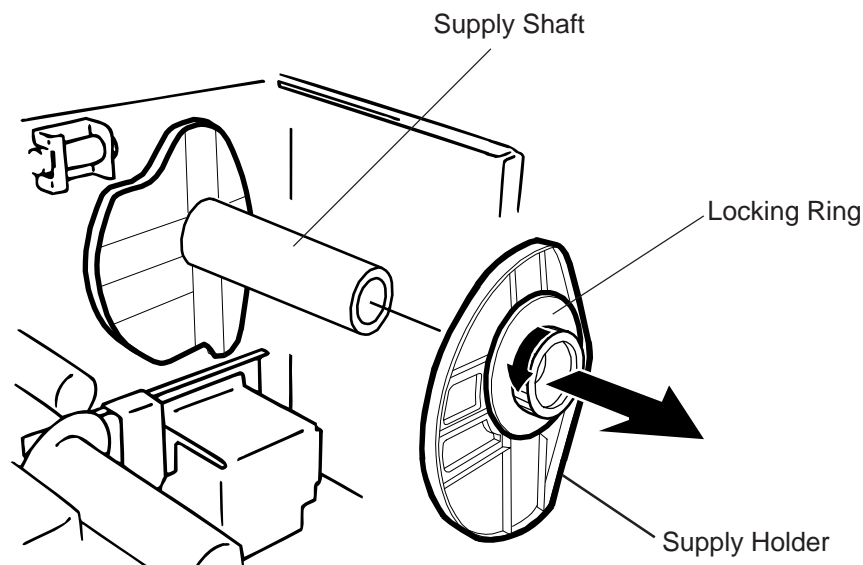

Fig. 5-2

4. Put the media on the supply shaft.
5. Pass the media around the damper, then pull the media towards the front of the printer.
6. Insert the ridge of the supply holder into the groove of the supply shaft until the media is fixed. Then turn the locking ring clockwise to secure the supply holder. This will centre the media automatically.  
**NOTE:** Do not over tighten the locking ring of the supply holder.

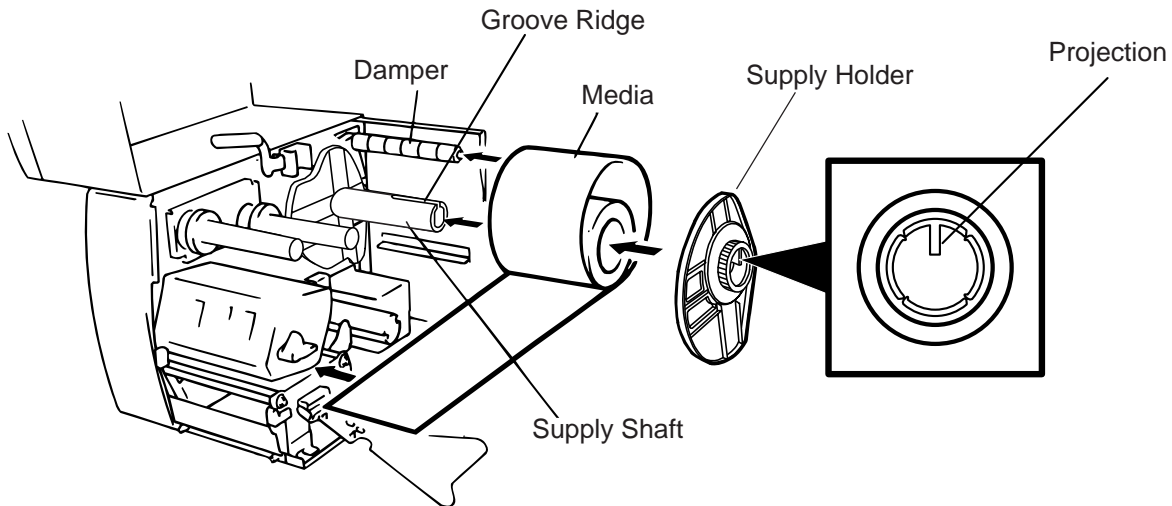

Fig. 5-3

7. Insert the media into the paper holders of the media guide, adjust the media guides to the media width, and tighten the locking screw.
8. Check that the media path through the printer is straight. The media should be centered under the print head.

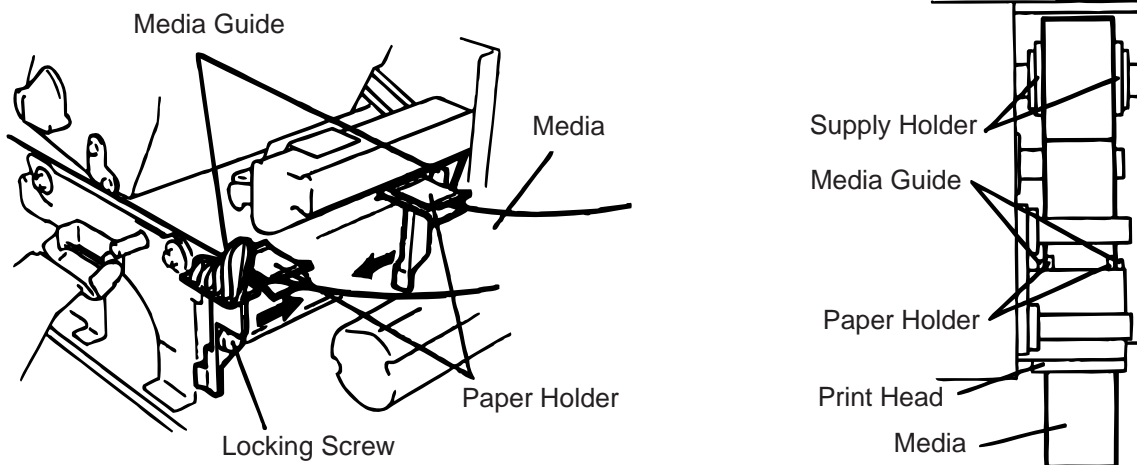

Fig. 5-4

**NOTE:** When using the label rolled with labels facing outside, please remove the upper plates of both paper holders using the following procedure. Failure to do this may cause a paper jam error. If you have any questions, please contact your nearest TOSHIBA TEC service representative.

### ■ Removing the paper holders' upper plates from the media guide

- ① Remove the two T-4x8 screws to detach the media guide from the printer.

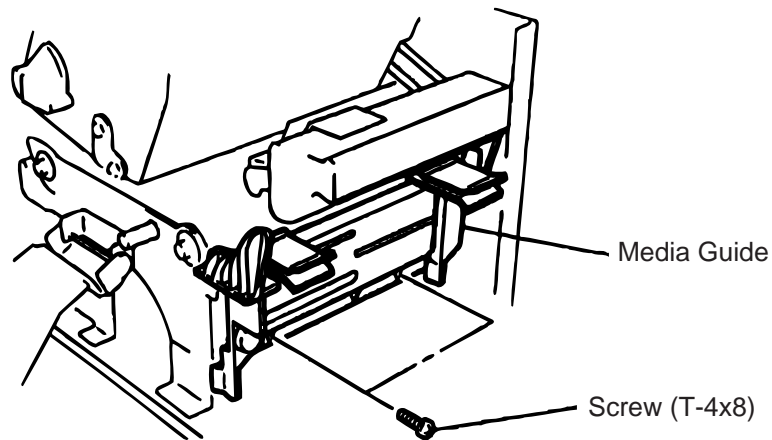

Fig. 5-5

- ② Remove the SM-3x6 screw or the SM-3x8 screw to detach the paper holders' upper plates from the media guide.

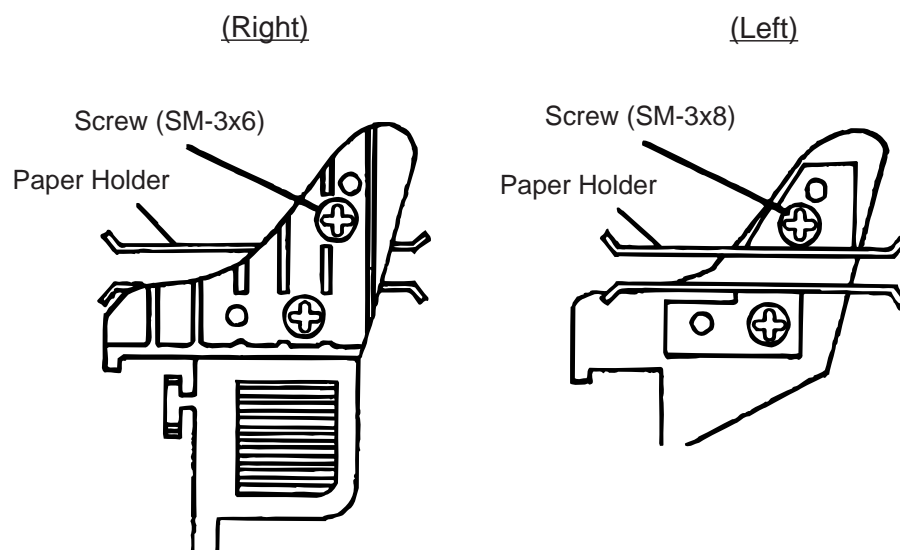

Fig. 5-6

- ③ Attach the media guide back in position.

**NOTE:** Do not lose the removed upper plates because they are required when using the label rolled with labels facing inside.

9. Set the black mark/feed gap sensor to the correct position by turning the adjusting knob. Turning the knob right will move the sensor towards the center of the media while turning left will move it away from the center of the media.

### ■ An easy way to set the black mark sensor position

- ① Pull the media about 500 mm out of the front of the printer, turn the media back on it's self and feed it under the print head past the sensor so that the black mark can be seen from above.
- ② Adjust the sensor position to that of the black mark (the upper hole indicates the position of the black mark sensor).

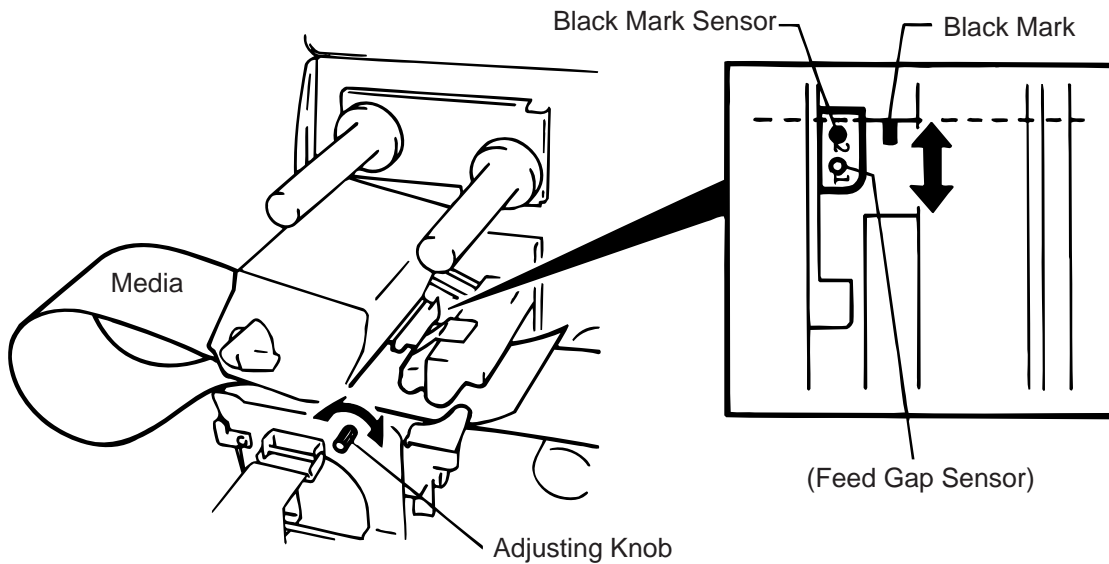

Fig. 5-7

**NOTE:** Make sure to set the sensor to detect the center of the black mark, otherwise a paper jam error could occur.

### ■ Setting the feed gap sensor position

- ① Adjust the sensor to detect on the gap (the lower hole indicates the position of the feed gap sensor.)

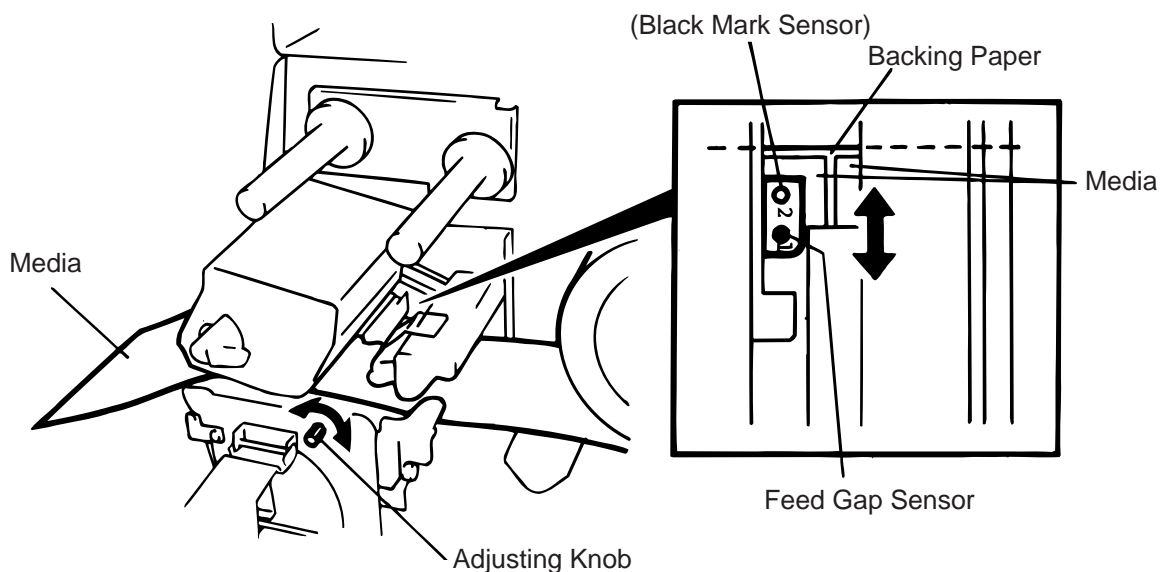

Fig. 5-8

10. The media is now loaded and the sensor position is set.

**Batch type:**

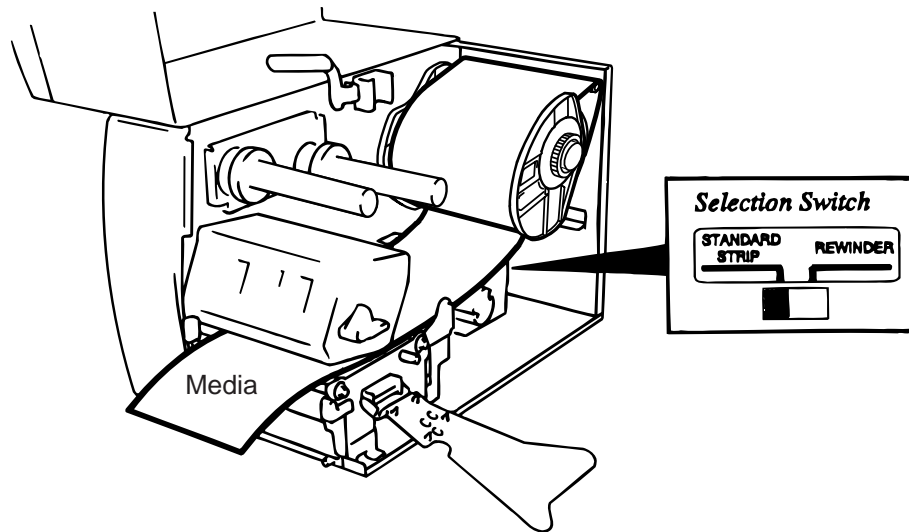

Fig. 5-9

**NOTE:** Set the selection switch to the STANDARD/STRIP position. Improper setting can affect the print quality.

**Strip type:**

- ① Remove enough labels from the leading edge media to leave 500 mm of backing paper exposed.
- ② Wind the backing paper onto the take-up spool and fix in position with the take-up clip. (Wind the paper counter clockwise around the spool as this is the direction it rotates.)
- ③ Rotate the take-up spool anti-clockwise a few times to take up any slack in the backing paper.

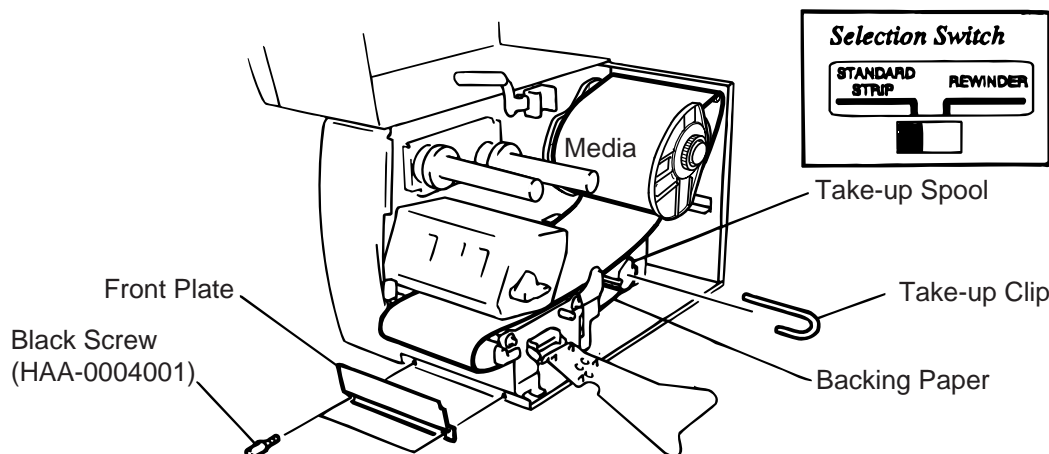

Fig. 5-10

- NOTES:**
1. The backing paper is easier to feed back to the take-up spool if the front plate is removed.
  2. When fitting the take-up clip the longer side of the clip should be fitted into the shallow groove on the take-up spool.
  3. Set the selection switch to the STANDARD/STRIP position.



**Cutter type:** Where a cutter is fitted load the media as standard and feed it through the cutter module. Swing cutter and rotary cutter are available as an option. They are used in the same way regardless of different shapes. Now, how to load the media using the swing cutter will be introduced.

- NOTES:**
1. Be sure to cut the backing paper of label. Cutting labels will cause the glue to stick to the cutter, which may affect the cutter quality and shorten the life.
  2. If a label winds onto the platen during cut issue, please contact your nearest TOSHIBA TEC service representative.
  3. For the cutter type, the selection switch can be set to either position.

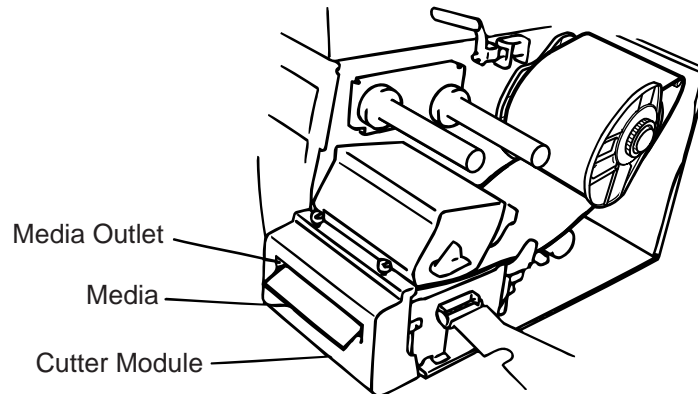

Fig. 5-11

**Built-in rewriter type:**

- ① Remove two black screws and front plate.
- ② Fit the rewriter guide plate to the strip shaft, then attach it with the sems screws.

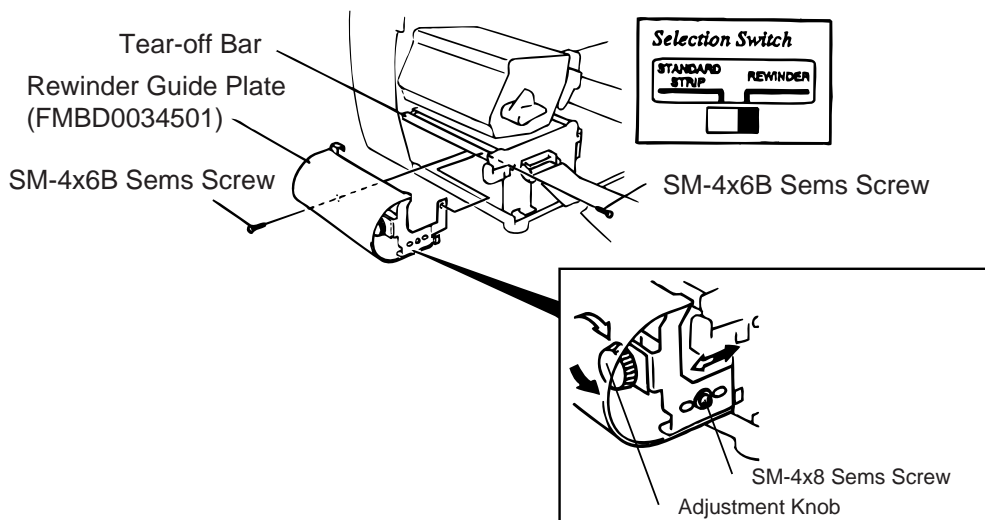

Fig. 5-12

**NOTES:** Set the selection switch to the REWINDER position.

- ③ Follow the procedure for strip type.
- ④ Adjustment

If the label skews when using built-in rewriter unit, turn the adjustment knob of the rewriter guide plate to correct the label feed. Clockwise turn moves the rewriter guide plate forward and counterclockwise moves it backward.

\* When labels skew to the right:

Loosen the SM-4x8 sems screw with a philips-head screw driver. Turn the adjustment knob clockwise, and tighten the SM-4x8 screw when the rewriter guide plate is positioned correctly.

\* When labels skew to the left:

Loosen the SM-4x8 screw with a phillips-head screw driver. Turn the adjustment knob counterclockwise, and tighten the SM-4x8 screw when the rewriter guide plate is positioned correctly.

## 6. LOADING THE RIBBON

### WARNING:

1. Do not touch moving parts. To reduce the risk that fingers, jewelry, clothing, etc., be drawn into the moving parts, push the switch in the "OFF" position to stop movement.
2. To avoid injury, be careful not to catch or jam your fingers while opening or closing the cover.

There are two types of media available for printing on, these are standard media and direct thermal media (a chemically treated surface). DO NOT LOAD a ribbon when using a direct thermal media.

1. When using a narrow width ribbon, slide the ribbon stoppers along the shafts to a position where the ribbon will be centered when it is fitted. When changing from a narrow width to a wider one rotate the ribbon stoppers by 90°, push them back to the correct position and then rotate back to lock.

**NOTE:** When attaching the ribbon stoppers, fit them to the shafts with the pinchers facing into the printer.

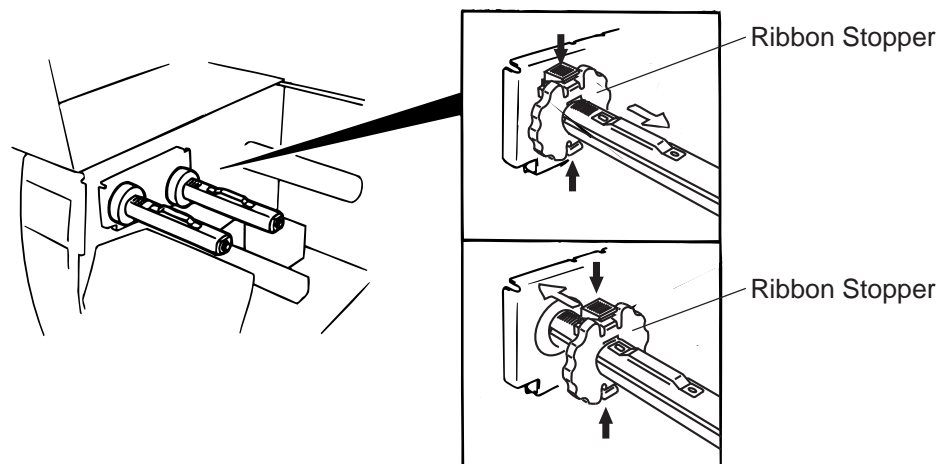

Fig. 6-1

2. Leaving plenty of slack between the spools, fit the ribbon as shown below. When the ribbon is fitted it must be positioned over the ribbon sensor.
3. Wind both shafts towards each other to tighten the ribbon.

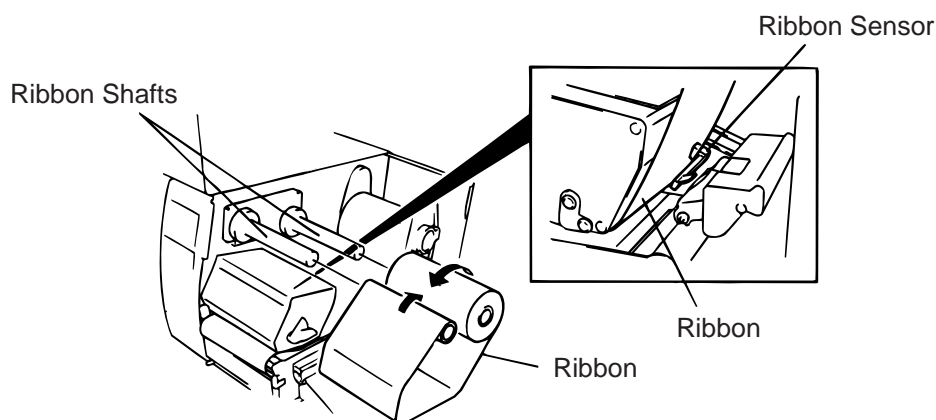

Fig. 6-2

4. Reset the ribbon shaft holder plate by aligning it with the ribbon shaft.
5. Turn the head lever clockwise to lower the print head.
6. Close the top cover.

## 7. INSERTING THE OPTIONAL PCMCIA CARD

### WARNING!

Turn the power OFF when inserting or removing the PCMCIA card.

### CAUTION:

1. To protect PCMCIA cards, discharge static electricity from your body by touching the printer rear cover prior to touching the PCMCIA cards.
2. Before turning off the power when using ATA card, be sure to press the **[PAUSE]** key and check the ON LINE LED is unlit. Failure to do this may erase the data which is being written to the ATA card.

1. Turn the power off.
2. Insert the PCMCIA card into the card slot at the rear of the printer.
3. Turn the power on.

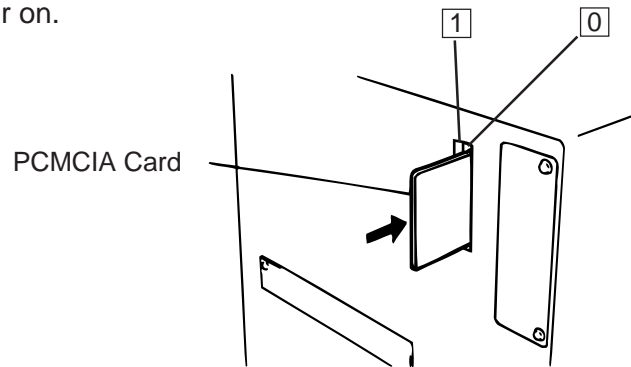

Fig. 7-1

- NOTES:**
1. Be sure to protect a PCMCIA card when not in use in the printer by putting it in its protective cover.
  2. Do not subject the card to any shocks or excessive forces.
  3. Do not expose the card to extremes of heat by either storing in direct sunlight or close to a heater.
  4. Do not expose the card to excessive humidity by wiping it with a wet cloth or storing it in a damp place.
  5. Before inserting or removing the card, make sure that the power switch is turned off.
  6. The following PCMCIA cards can be used.

Type	Maker	Description	Remarks
ATA Card		A card conforming to the PC card ATA standard	_____
LAN Card	3 COM	Ether Link III 3C589D PC card	Install into the slot (1) only. (This card installed into the slot (0) will not work.)
Flash Memory Card (4 MB)	Maxell	EF-4M-TB <input type="checkbox"/> CC	_____
		EF-4M-TB <input type="checkbox"/> DC	

7. Install the LAN card into the slot (1).

---

## 8. CARE/HANDLING OF THE MEDIA AND RIBBON

**CAUTION:**

*Be sure to read carefully and understand the Supply Manual. Use only media and ribbon which meet specified requirements. Use of non-specified media and ribbon may shorten the head life and result in problems with bar code readability or print quality. All media and ribbon should be handled with care to avoid any damage to the media, ribbon or printer. Read the following guideline carefully.*

- Do not store the media and ribbon for longer than the manufactures recommended shelf life.
- Store media rolls on the flat end, do not store them on the curved sides as this might flatten that side causing erratic media advance and poor print quality.
- Store the media in plastic bags and always reseal after opening. Unprotected media can get dirty and the extra abrasion from the dust and dirt particles will shorten the print head life.
- Store the media and ribbon in a cool, dry place. Avoid areas where they would be exposed to direct sunlight, high temperature, high humidity, dust or gas.
- The thermal paper used for direct thermal printing must not have the specifications which exceed  $\text{Na}^+$  800 ppm,  $\text{K}^+$  250 ppm and  $\text{CL}^-$  500 ppm.
- Some ink used on pre-printed labels may contain ingredients which shorten the print head's product life. Do not use labels pre-printed with ink which contain hard substances such as carbonic calcium ( $\text{CaCO}_3$ ) and kaolin ( $\text{Al}_2\text{O}_3, 2\text{SiO}_2, 2\text{H}_2\text{O}$ ).

For further information please contact your local distributor or your media and ribbon manufacturer.

## 9. GENERAL MAINTENANCE

### WARNING:

1. Be careful when handling the print head as it becomes very hot.
2. Care must be taken not to injure yourself with the printer paper cutter.
3. Do not touch moving parts. To reduce the risk that fingers, jewelry, clothing, etc., be drawn into the moving parts, push the switch in the "OFF" position to stop movement.
4. To avoid injury, be careful not to catch or jam your fingers while opening or closing the cover.

### 9.1 Cleaning

To help retain the high quality and performance of your printer it should be regularly cleaned. The greater the usage of the printer, the more frequent the cleaning. (i.e. low usage=weekly : high usage=daily). A print head cleaner is not enclosed with the printer, so please inquire at your local distributor.

1. Turn the power off.
2. Open the top cover.
3. Turn the head lever to raise the print head.
4. Remove the ribbon and media.
5. Clean the element of print head with print head cleaner.
6. Wipe the platen, feed roller and pinch roller with a cleaner moistened with alcohol. Remove dust or foreign substances from the internal part of the printer, if any.

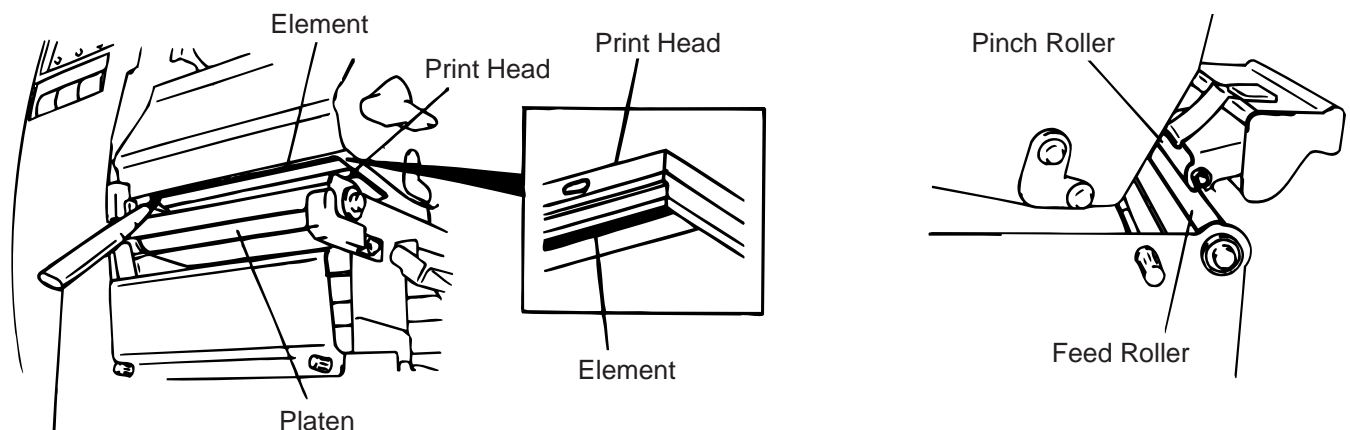

Print Head Cleaner  
(24089500013)

Fig. 9-1

### WARNING:

1. Be sure to disconnect the power cord prior of performing any maintenance.
2. Do not use any tool that may damage the print head.
3. DO NOT POUR WATER directly onto the printer.

## 9.2 Covers and Panels

The covers should be cleaned by wiping with a dry cloth or a cloth slightly dampened with a mild detergent solution.

**NOTE:** Clean the printer cover with an electrostatic free cleaner for automated office equipment.

### WARNING:

1. **DO NOT POUR WATER** directly onto the printer.
2. **DO NOT APPLY** cleaner or detergent directly onto any cover or panel.
3. **NEVER USE THINNER OR OTHER VOLATILE SOLVENT** on the plastic covers.
4. **DO NOT** clean the panel covers or the supply window with alcohol as it may cause them to discolor, lose their shape or develop structural weakness.

## 9.3 Removing Jammed Paper

1. Turn the power off.
2. Open the top cover.
3. Turn the head lever to position ③, then release the ribbon shaft holder plate.
4. Remove the flanged screw to detach the media guide plate. (See Fig. 9-2.)
5. Remove the ribbon and media.
6. Remove the jammed paper. **DO NOT USE** any sharp implement or tool as these could damage the printer.
7. Clean the print head and platen, then remove any further dust or foreign substances.
8. Place the portion ② of the media guide plate on the media sensor. Secure the media guide plate with the flanged screw.

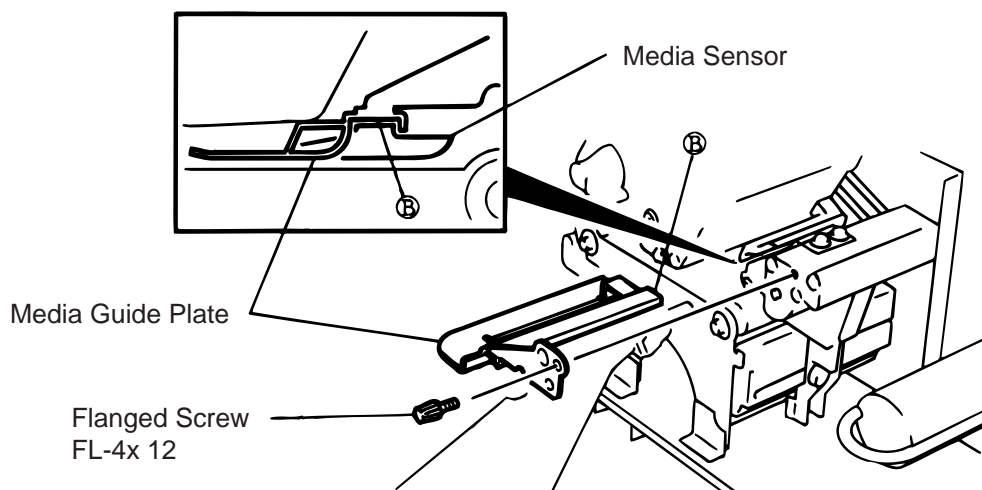

Fig. 9-2

9. Paper jams in the cutter unit can be caused by wear or residual glue from label stock on the cutter. Do not use none specified media in the cutter. If you get frequent jams in the cutter contact your Authorized Service representative.

## ■ Cleaning the Cutter Unit

### WARNING!

1. Be sure to turn the power off before cleaning the cutter unit.
2. The cutters are sharp and care should be taken not to injure yourself when cleaning.

The swing cutter and rotary cutter are available as an option. They are both cleaned in the same way regardless of different shapes. Now, how to clean the cutter unit installing the swing cutter will be introduced.

1. Loosen two screws and remove the cutter cover.
2. Remove the white screw and media guide.
3. Remove the jammed paper and trash.
4. Clean the cutter with dry cloth.

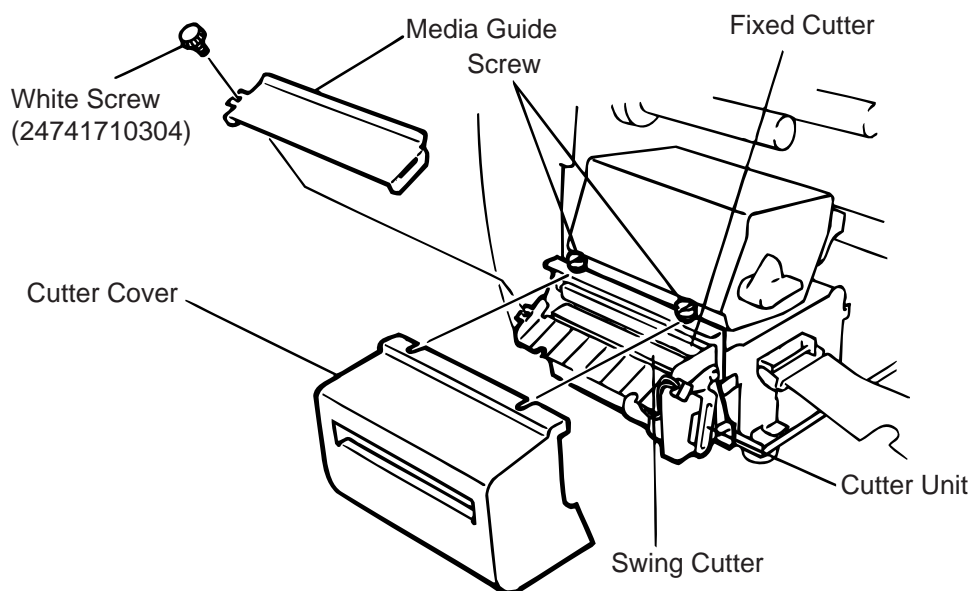

Fig. 9-3

5. Assembling is reverse order of removal.

## ■ Auto Ribbon Saving Mode

Auto ribbon saving function is activated when a no print area extends more than 17 mm. For further information on this function, please ask your nearest TOSHIBA TEC service representative.

**NOTE:** According to the relation between the outer diameter of rewound ribbon and print speed, ribbon loss per saving varies as follows:

Print speed	Ribbon loss
3"/sec.	Approx. 5 mm
5"/sec.	Approx. 8 mm
8"/sec.	Approx. 17 mm

## 9.4 Threshold Setting

For the printer to maintain a constant print position it uses the feed gap sensor to detect the gap between labels by measuring the amount of light passing through the media. When the media is pre-printed, the darker (or more dense) inks can interfere with this process causing paper jammed errors. To get around this problem a minimum threshold can be set for the sensor in the following way.

### ■ Threshold setting procedure

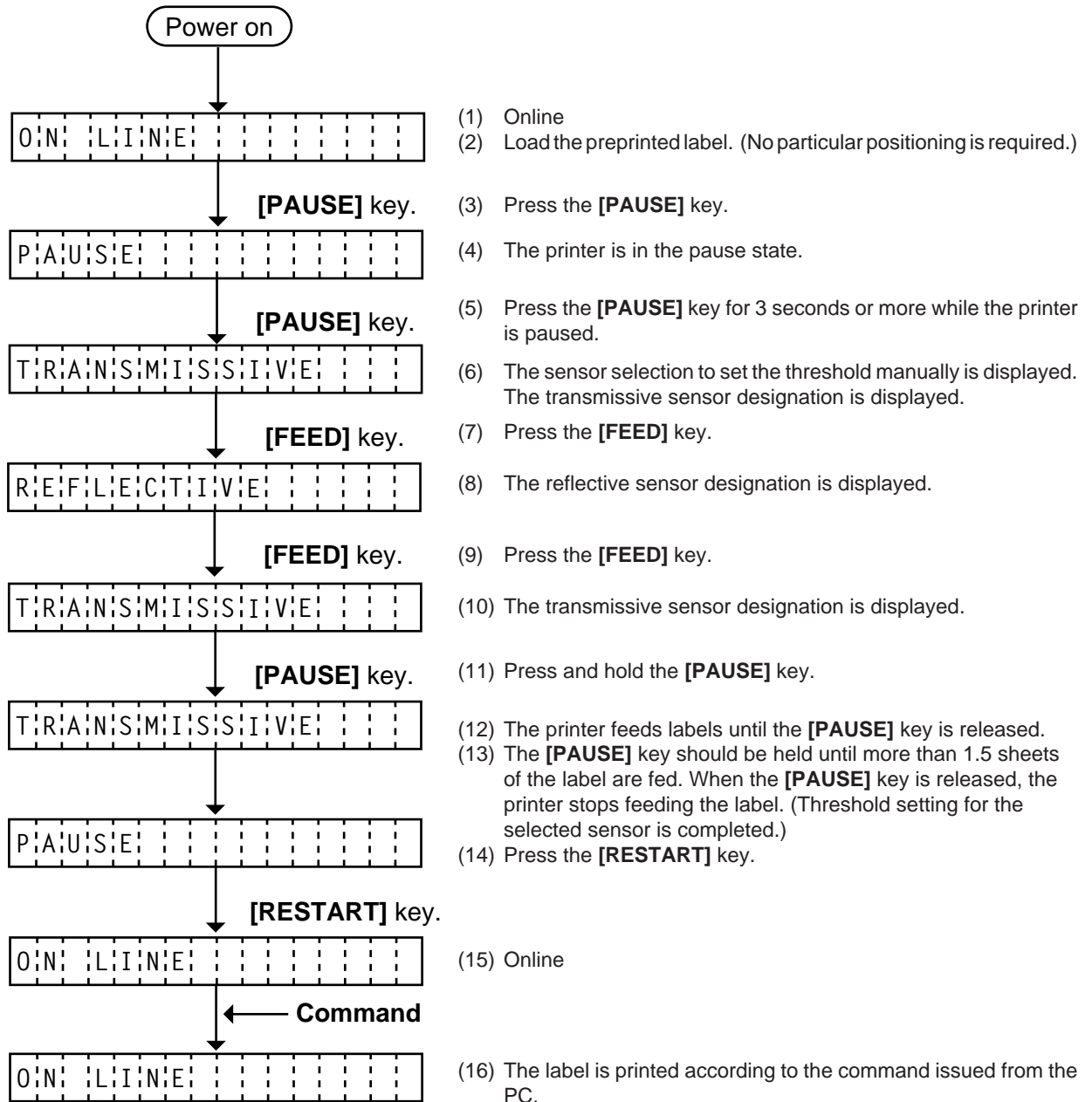

#### < Supplementary Explanation >

- (1) When the **[PAUSE]** key is released within 3 seconds while printer pauses, the **[PAUSE]** key is invalid.
- (2) When the threshold is programmed, 1.5 sheets of the label should be fed. (If less than 1.5 labels are fed, the threshold may not be properly programmed. In this case, reprogramming is required.)
- (3) When the **[PAUSE]** key is pressed for 3 seconds or more in a head-up state, the **[PAUSE]** key is invalid.
- (4) During a label feed, an error including the paper end, ribbon end or cutter error is not detected.



## 10. TROUBLESHOOTING

### WARNING:

*If you cannot solve a problem with the following solutions, do not attempt to repair it yourself. Turn the power off, unplug the printer, then contact your Authorized Service representative for assistance.*

Error Message	Problem	Solution
PAPER JAM ****	<ol style="list-style-type: none"> <li>The media is not fitted correctly.</li> <li>The media path is jammed and does not feed smoothly.</li> <li>The installed media type does not match the selected sensor.</li> <li>The black mark position on the media does not match the sensor position.</li> <li>The installed media size is different from the programmed size.</li> <li>The feed gap sensor cannot see the difference between the print area and the gap.</li> </ol>	<ol style="list-style-type: none"> <li>Re-fit the media correctly. → Press the <b>[RESTART]</b> key.</li> <li>Remove the cause of the jam and replace the media correctly. → Press the <b>[RESTART]</b> key.</li> <li>Turn the power off then on again. Select the correct sensor. → Feed the media.</li> <li>Adjust the sensor position. → Press the <b>[RESTART]</b> key.</li> <li>Turn the power off then on again. Set the correct media size. → Feed the media.</li> <li>Set the threshold (see page 9-4). Else Turn the power off and call your Authorized Service representative.</li> </ol>
HEAD OPEN ****	Feed or printing has been attempted while the print head is raised.	Lower the print head. → Press the <b>[RESTART]</b> key.
NO PAPER ****	The media has run out.	Load new media. → Press the <b>[RESTART]</b> key.
NO RIBBON ****	The ribbon has run out.	Load a new ribbon. → Press the <b>[RESTART]</b> key.
REWIND FULL ****	Too much backing paper or media is wound on the internal take-up spool.	Remove the backing paper or media from the internal take-up spool. Then press the <b>[RESTART]</b> key.
EXCESS HEAD TEMP	The print head is too hot.	Turn the power off and decrease the print head temperature.
RIBBON ERROR ****	There is a fault with the ribbon sensor.	Turn the power off. Contact your Authorized Service representative.

Error Message	Problem	Solution
CUTTER ERROR ****	Media is jammed in the cutter.	Remove the jammed media and feed the undamaged media through the cutter. → Press the <b>[RESTART]</b> key. Else Turn the power off and contact your Authorized Service representative.
FLASH WRITE ERR.	An error has occurred when loading data onto a flash memory card or ATA card.	1. Turn the power off, re-seat the flash memory card or ATA card and try again. 2. Replace the flash memory card or ATA card and retry. 3. Turn the power off and contact your Authorized Service representative.
FORMAT ERROR	An error has occurred while formatting a flash memory card or ATA card.	1. Turn the power off, re-seat the flash memory card or ATA card and try again. 2. Replace the flash memory card or ATA card and retry. 3. Turn the power off and contact your Authorized Service representative.
FLASH CARD FULL	No more data can be saved in the flash memory card or ATA card.	Replace the card with a new one and re-send data. (In case of flash memory card, only 1MB and 4MB cards can be used.)
COMMS ERROR	A communication error has occurred with the host.	Turn the power off then on again or press the <b>[RESTART]</b> key. Check the program data. → Call your Authorized Service representative if necessary.
example) PC001; 0A00,   Command error 0300, 2, 2	When an error is detected in a command 16 bytes of the command are displayed. (ESC, LF, NUL are not displayed.)	Correct the command and re-send it again.
Other Error Message	Hardware or software trouble.	Turn the power off then on again. If the problem still exists turn the power off and contact your Authorized Service representative.

**NOTE:** If an error is not cleared by pressing the **[RESTART]** key, the power must be switched off then on again.

After the power has been switched off and on, all print data in the printer is cleared.

\*\*\*\* denotes a remaining count of unprinted labels.

Problem	Solution
No print.	<ol style="list-style-type: none"> <li>1. Check that media and the ribbon is loaded correctly.</li> <li>2. Check whether the print head is set correctly or not.</li> <li>3. Check the cabling between the printer and the host.</li> </ol>
Dots missing in the print.	Dirty print head. → Clean the print head. Call your Authorized Service representative if necessary.
Unclear (or blurred) printing.	<ol style="list-style-type: none"> <li>1. Dirty print head. → Clean the print head.</li> <li>2. Bad or faulty ribbon. → Replace ribbon.</li> <li>3. Poor media quality. → Change media type.</li> </ol>
Power does not come on.	<ol style="list-style-type: none"> <li>1. Plug power cord into an AC socket.</li> <li>2. Check the circuit breakers or fuses.</li> <li>3. Plug another appliance into the AC socket to check if there is power supplied.</li> </ol> Call your Authorized Service representative if necessary.
Printer does not cut.	Check for a paper jam in the cutter. Call your Authorized Service representative if necessary.
You see a raised nap where the media has been cut.	<ol style="list-style-type: none"> <li>1. Clean the cutter blades.</li> <li>2. The blades are worn. → Call your Authorized Service representative.</li> </ol>





***TEC***  
**TOSHIBA TEC CORPORATION**

PRINTED IN JAPAN  
EO1-33008

## Free Manuals Download Website

<http://myh66.com>

<http://usermanuals.us>

<http://www.somanuals.com>

<http://www.4manuals.cc>

<http://www.manual-lib.com>

<http://www.404manual.com>

<http://www.luxmanual.com>

<http://aubethermostatmanual.com>

Golf course search by state

<http://golfingnear.com>

Email search by domain

<http://emailbydomain.com>

Auto manuals search

<http://auto.somanuals.com>

TV manuals search

<http://tv.somanuals.com>