

TEC

TEC Barcode Printer

B-492L/R-TH10 SERIES

Owner's Manual

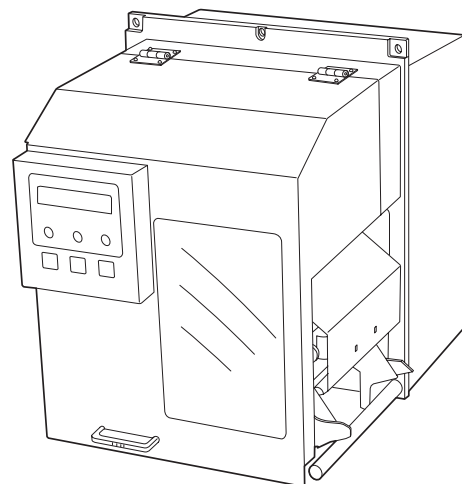

TOSHIBA TEC CORPORATION

For QP

CE Compliance (for EU only)

This product complies with the requirements of EMC and Low Voltage Directives including their amendments.

VORSICHT:

- Schallemission: unter 70dB (A) nach DIN 45635 (oder ISO 7779)
- Die für das Gerät Vorgesehene Steckdose muß in der Nähe des Gerätes und leicht zugänglich sein.

WARNING!

This is a Class A product. In a domestic environment this product may cause radio interference in which case the user may be required to take adequate measures.

ATTENTION!

Ce produit est de classe A. Dans un environnement domestique, il peut causer des interférences radio. Auquel cas, l'utilisateur sera amené à prendre les mesures adéquates.

WARNUNG!

Dies ist ein Klasse A Produkt. In einer örtlichen Umgebung kann dieses Gerät Funkstörungen verursachen.

¡ATENCIÓN!

Este es un producto de la clase A. En ambientes domésticos éste producto puede causar radio interferencias en cuyo caso el usuario deberá tomar las medidas oportunas.

VERWITTING!

Dit is een klasse A produkt. Het gebruik hiervan kan radio interferenties veroorzaken die de gebruiker ertoe kunnen dwingen sommige maatregelen te moeten treffen.

ATTENZIONE!

Questo è un prodotto in Classe A. In un contesto domestico, questo prodotto può causare interferenze radio, per le quali l'utente dovrebbe prendere le adeguate precauzioni.

For QQ

This equipment has been tested and found to comply with the limits for a Class A digital device, pursuant to Part 15 of the FCC Rules. These limits are designed to provide reasonable protection against harmful interference when the equipment is operated in a commercial environment. This equipment generates, uses, and can radiate radio frequency energy and, if not installed and used in accordance with the instruction manual, may cause harmful interference to radio communications. Operations of this equipment in a residential area is likely to cause harmful interference in which case the user will be required to correct the interference at his own expense.

(for USA only)

Changes or modifications not expressly approved by manufacturer for compliance could void the user's authority to operate the equipment.

"This Class A digital apparatus meets all requirements of the Canadian Interference-Causing Equipment Regulations."

"Cet appareil numérique de la classe A respecte toutes les exigences du Règlement sur le matériel brouilleur du Canada."

(for CANADA only)

Safety Summary

Personal safety in handling or maintaining the equipment is extremely important. Warnings and Cautions necessary for safe handling are included in this manual. All warnings and cautions contained in this manual should be read and understood before handling or maintaining the equipment.

Do not attempt to effect repairs or modifications to this equipment. If a fault occurs that cannot be rectified using the procedures described in this manual, turn off the power, unplug the machine, then contact your authorised TOSHIBA TEC representative for assistance.

Meanings of Each Symbol



This symbol indicates warning items (including cautions). Specific warning contents are drawn inside the Δ symbol. (The symbol on the left indicates a general caution.)



This symbol indicates prohibited actions (prohibited items). Specific prohibited contents are drawn inside or near the \odot symbol. (The symbol on the left indicates “no disassembling”.)



This symbol indicates actions which must be performed. Specific instructions are drawn inside or near the \bullet symbol. (The symbol on the left indicates “disconnect the power cord plug from the outlet”.)



WARNING

This indicates that there is the risk of **death** or **serious injury** if the machines are improperly handled contrary to this indication.



Any other than the specified AC voltage is prohibited.

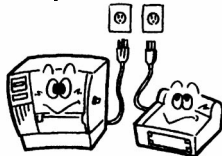

Do not use voltages other than the voltage (AC) specified on the rating plate, as this may cause **fire** or **electric shock**.



Prohibited

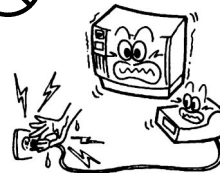

Do not plug in or unplug the power cord plug with wet hands as this may cause **electric shock**.



Prohibited



If the machines share the same outlet with any other electrical appliances which consume large amounts of power, the voltage will fluctuate widely each time these appliances operate. Be sure to provide an exclusive outlet for the machine as this may cause **fire** or **electric shock**.



Prohibited



Do not place metal objects or water-filled containers such as flower vases, flower pots or mugs, etc. on top of the machines. If metal objects or spilled liquid enter the machines, this may cause **fire** or **electric shock**.



Prohibited

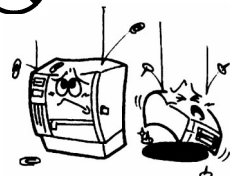

Do not insert or drop metal, flammable or other foreign objects into the machines through the ventilation slits, as this may cause **fire** or **electric shock**.



Prohibited

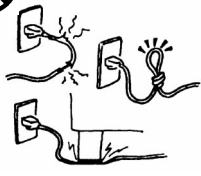

Do not scratch, damage or modify the power cords. Also, do not place heavy objects on, pull on, or excessively bend the cords, as this may cause **fire** or **electrical shock**.



Disconnect the plug.











If the machines are dropped or their cabinets damaged, first turn off the power switches and disconnect the power cord plugs from the outlet, and then contact your authorised TOSHIBA TEC representative for assistance. Continued use of the machine in that condition may cause **fire** or **electric shock**.



Disconnect the plug.



Continued use of the machines in an abnormal condition such as when the machines are producing smoke or strange smells may cause **fire** or **electric shock**. In these cases, immediately turn off the power switches and disconnect the power cord plugs from the outlet. Then, contact your authorised TOSHIBA TEC representative for assistance.

 <p>Disconnect the plug.</p> 	<p>If foreign objects (metal fragments, water, liquids) enter the machines, first turn off the power switches and disconnect the power cord plugs from the outlet, and then contact your authorised TOSHIBA TEC representative for assistance. Continued use of the machine in that condition may cause fire or electric shock.</p>	 <p>Disconnect the plug.</p> 	<p>When unplugging the power cords, be sure to hold and pull on the plug portion. Pulling on the cord portion may cut or expose the internal wires and cause fire or electric shock.</p>
 <p>Connect a grounding wire.</p> 	<p>Ensure that the equipment is properly grounded. Extension cables should also be grounded. Fire or electric shock could occur on improperly grounded equipment.</p>	 <p>No disassembling.</p> 	<p>Do not remove covers, repair or modify the machine by yourself. You may be injured by high voltage, very hot parts or sharp edges inside the machine.</p>



CAUTION

This indicates that there is the risk of personal **injury** or **damage** to objects if the machines are improperly handled contrary to this indication.

Precautions

The following precautions will help to ensure that this machine will continue to function correctly.

- Try to avoid locations that have the following adverse conditions:
 - * Temperatures out of the specification
 - * Shared power source
- * Direct sunlight
- * Excessive vibration
- * High humidity
- * Dust/Gas
- The cover should be cleaned by wiping with a dry cloth or a cloth slightly dampened with a mild detergent solution. NEVER USE THINNER OR ANY OTHER VOLATILE SOLVENT on the plastic covers.
- USE ONLY TOSHIBA TEC SPECIFIED paper and ribbons.
- DO NOT STORE the paper or ribbons where they might be exposed to direct sunlight, high temperatures, high humidity, dust, or gas.
- Ensure the printer is operated on a level surface.
- Any data stored in the memory of the printer could be lost during a printer fault.
- Try to avoid using this equipment on the same power supply as high voltage equipment or equipment likely to cause mains interference.
- Unplug the machine whenever you are working inside it or cleaning it.
- Keep your work environment static free.
- Do not place heavy objects on top of the machines, as these items may become unbalanced and fall causing **injury**.
- Do not block the ventilation slits of the machines, as this will cause heat to build up inside the machines and may cause **fire**.
- Do not lean against the machine. It may fall on you and could cause **injury**.
- Care must be taken not to injure yourself with the printer paper cutter.
- Unplug the machine when it is not used for a long period of time.

Request Regarding Maintenance

- Utilize our maintenance services.
After purchasing the machine, contact your authorised TOSHIBA TEC representative for assistance once a year to have the inside of the machine cleaned. Otherwise, dust will build up inside the machines and may cause a **fire** or a **malfunction**. Cleaning is particularly effective before humid rainy seasons.
- Our preventive maintenance service performs the periodic checks and other work required to maintain the quality and performance of the machines, preventing accidents beforehand.
For details, please consult your authorised TOSHIBA TEC representative for assistance.
- Using insecticides and other chemicals
Do not expose the machines to insecticides or other volatile solvents. This will cause the cabinet or other parts to deteriorate or cause the paint to peel.

TABLE OF CONTENTS

	Page
1. PRODUCT OVERVIEW.....	1-1
1.1 Introduction.....	1-1
1.2 Features	1-1
1.3 Unpacking	1-1
1.4 Accessories	1-1
1.5 Appearance of the Printer.....	1-2
1.5.1 Dimensions.....	1-2
1.5.2 Front View	1-3
1.5.3 Side View	1-3
1.5.4 Interior	1-4
1.5.5 Operation Panel	1-4
1.6 Appearance of the Power Supply Unit	1-5
1.6.1 Dimensions.....	1-5
1.6.2 Front View	1-5
2. PRINTER SETUP	2-1
2.1 Precautions	2-1
2.2 Procedure before Operation	2-2
2.3 Fitting the Fan Filter.....	2-2
2.4 Connecting the Cables to Your Printer.....	2-3
2.5 Connecting the Power Cord.....	2-4
2.6 Turning the Printer ON/OFF.....	2-5
2.6.1 Turning ON the Printer	2-5
2.6.2 Turning OFF the Printer	2-5
2.7 Loading the Media	2-6
2.8 Loading the Ribbon	2-11
2.9 Inserting the Optional PCMCIA Cards	2-12
2.10 Test Print.....	2-13
3. ON LINE MODE	3-1
3.1 Operation Panel.....	3-1
3.2 Operation.....	3-2
4. MAINTENANCE	4-1
4.1 Cleaning	4-1
4.1.1 Print Head/Platen	4-1
4.1.2 Media Guide Plate/Pinch Roller/Sensors.....	4-2
4.1.3 Paper Holder	4-4
4.1.4 Covers and Panels.....	4-4
4.2 Care/Handling of the Media and Ribbon	4-5
5. TROUBLESHOOTING	5-1
5.1 Error Messages	5-1
5.2 Possible Problems.....	5-2
5.3 Removing Jammed Media	5-3
5.4 Threshold Setting	5-3
6. PRINTER OPERATION.....	6-1
6.1 Overview	6-1
6.2 Installing the Printer Drivers.....	6-1
6.2.1 System Requirements.....	6-2
6.2.2 Driver Installation.....	6-2
6.2.3 Uninstalling the TEC B-492 Printer Driver	6-6

APPENDIX 1 SPECIFICATIONS	A1-1
A1.1 Printer.....	A1-1
A1.2 Options.....	A1-2
A1.3 Media	A1-2
A1.3.1 Media Type	A1-2
A1.3.2 Detection Area of the Transmissive Sensor.....	A1-3
A1.3.3 Detection Area of the Reflective Sensor	A1-4
A1.3.4 Effective Print Area	A1-4
A1.4 Ribbon.....	A1-5
APPENDIX 2 MESSAGES AND LED	A2-1
APPENDIX 3 INTERFACE.....	A3-1
APPENDIX 4 SYSTEM MODE.....	A4-1
A4.1 Operation Panel.....	A4-1
A4.2 Overview	A4-2
A4.3 Reset Mode	A4-3
A4.4 Self-Diagnostic Test	A4-3
A4.5 Printer Parameter Fine Adjustment.....	A4-6
A4.6 Test Print.....	A4-14
A4.7 Dump Mode.....	A4-20
A4.8 Additional Information.....	A4-21
A4.8.1 Self-Diagnostic Test Result Sample and Descriptions.....	A4-21
A4.8.2 Maintenance Counter/Parameter Check Print Sample and Descriptions.....	A4-24
A4.8.3 Magnified Views of Slant Line Pattern.....	A4-27
APPENDIX 5 PRINT SAMPLES	A5-1
GLOSSARIES	
INDEX	

CAUTION!

1. This manual may not be copied in whole or in part without prior written permission of TOSHIBA TEC.
2. The contents of this manual may be changed without notification.
3. Please refer to your local Authorized Service representative with regard to any queries you may have in this manual.

1. PRODUCT OVERVIEW

1.1 Introduction

Thank you for choosing the TEC B-492L/R series barcode printer. This Owner's Manual contains valuable information from general set-up to confirming the printer's operation using test prints. You should read it carefully to help you gain maximum performance and life from your printer. This manual should be kept close at hand for everyday reference. Please contact your TOSHIBA TEC representative for further information concerning this manual.

1.2 Features

The B-492L/R printer has the following features:

- Superior hardware, including a specially developed 12 dots/mm (300 dots/inch) thermal print head which gives very clear print quality at print speeds of 127 mm/sec. (5 inches/sec.), 203.2 mm/sec. (8 inches/sec.), and 254 mm/sec. (10 inches/sec.).
- Separation of the power supply unit realized a compact body of the printer.
- When the optional interface board is installed, Web functions such as remote maintenance and other advanced network functions are available.
- The PCMCIA Interface Board and the KB-80-QM Keyboard Unit are provided as optional equipment.

1.3 Unpacking

Unpack the printer as per the Unpacking Instructions supplied with the printer.

NOTES:

1. Check for damage or scratches on the printer. However, please note that TOSHIBA TEC shall have no liability for any damage of any kind sustained during transportation of the product.
2. Keep the cartons and pads for future transportation of the printer.

1.4 Accessories

When unpacking the printer, please check that the following accessories are supplied with the printer.

- Owner's Manual (1 copy) (Doc./No. EO1-33032)
 Fan Filter (P/No. FMBB0036801)
 CD-ROM (P/No. FMQB0083801)



- US Power Cord (1 pc.) (P/No. FBCB0030202)

- EU Power Cord (1 pc.) (P/No.: EKA-0055001)

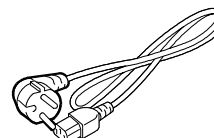
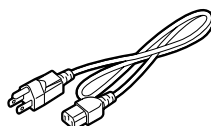

1.5 Appearance of the Printer

1.5.1 Dimensions

Dimension: mm+(inch)

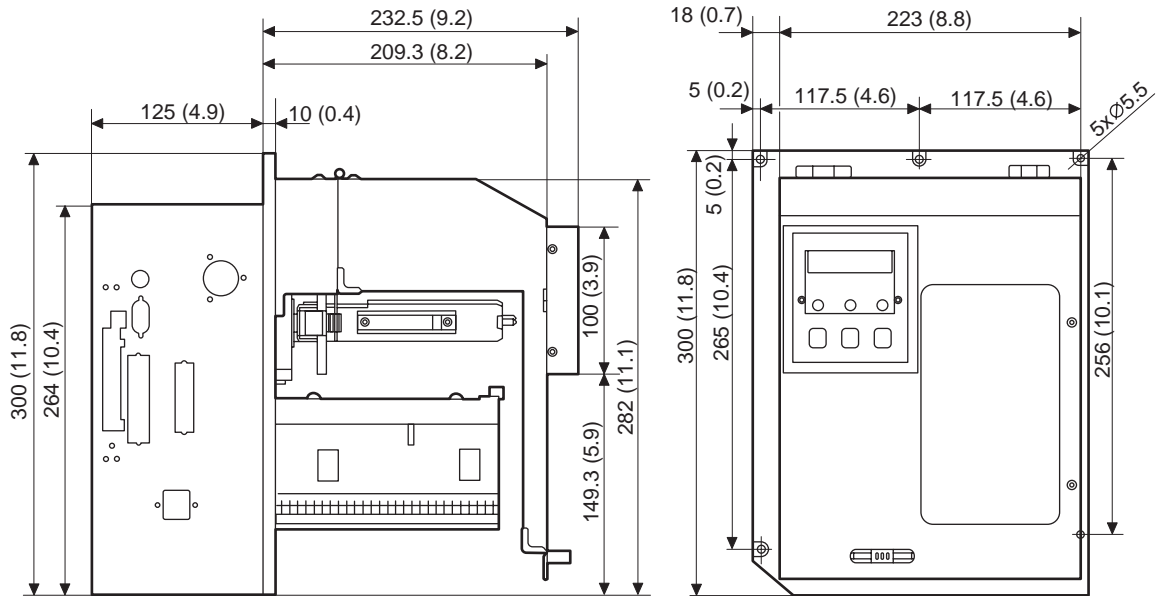

[L Type]

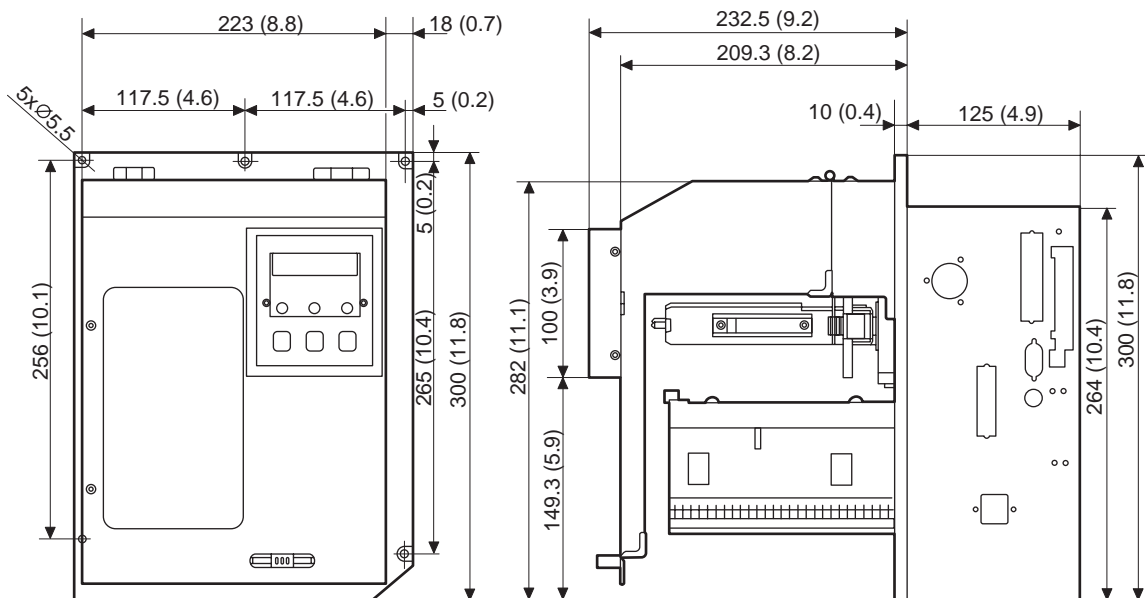

[R Type]

1.5.2 Front View

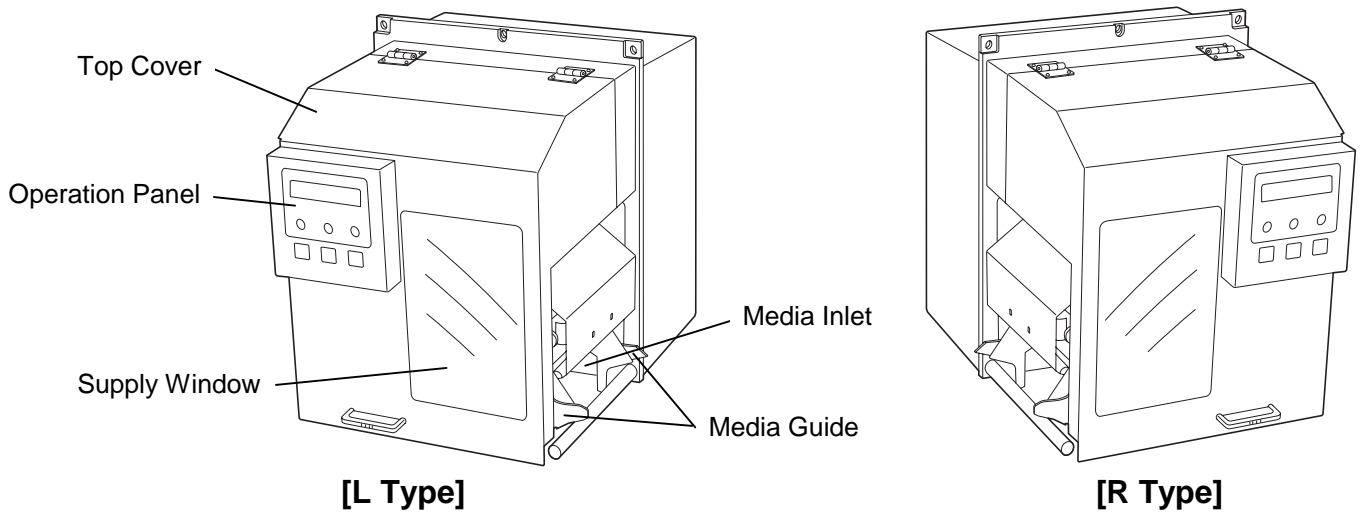

1.5.3 Side View

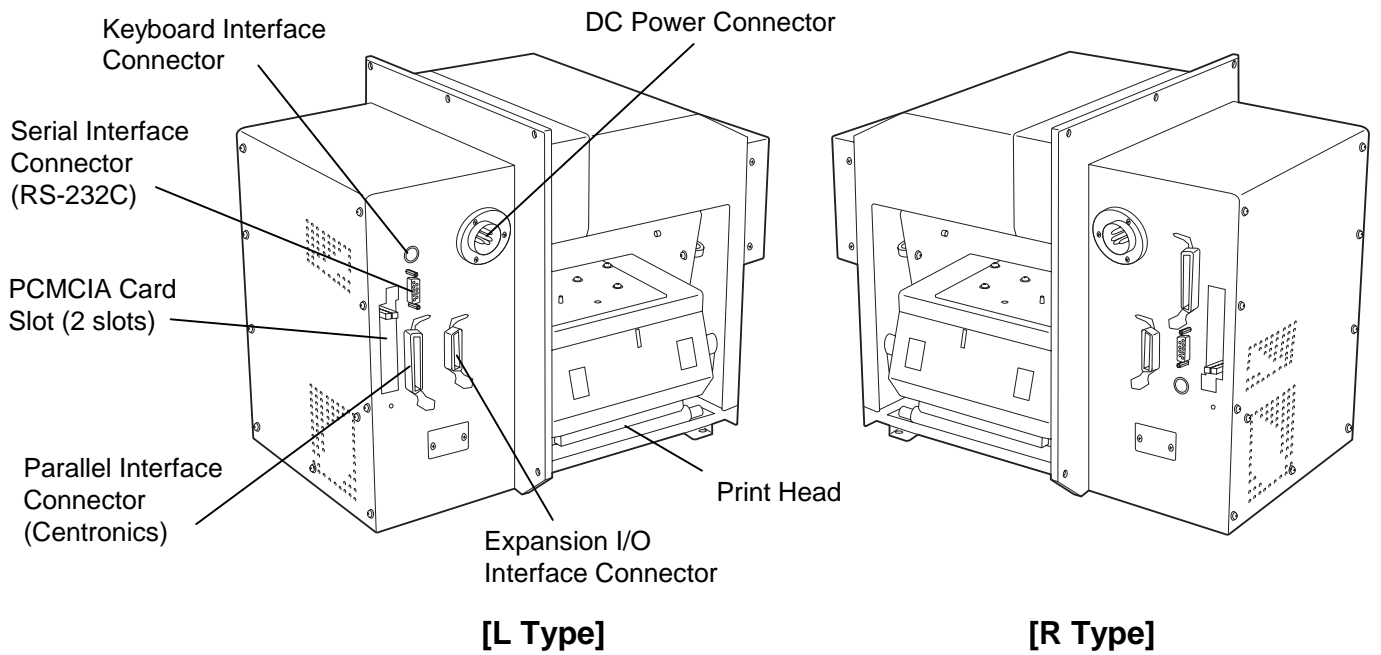

1.5.4 Interior

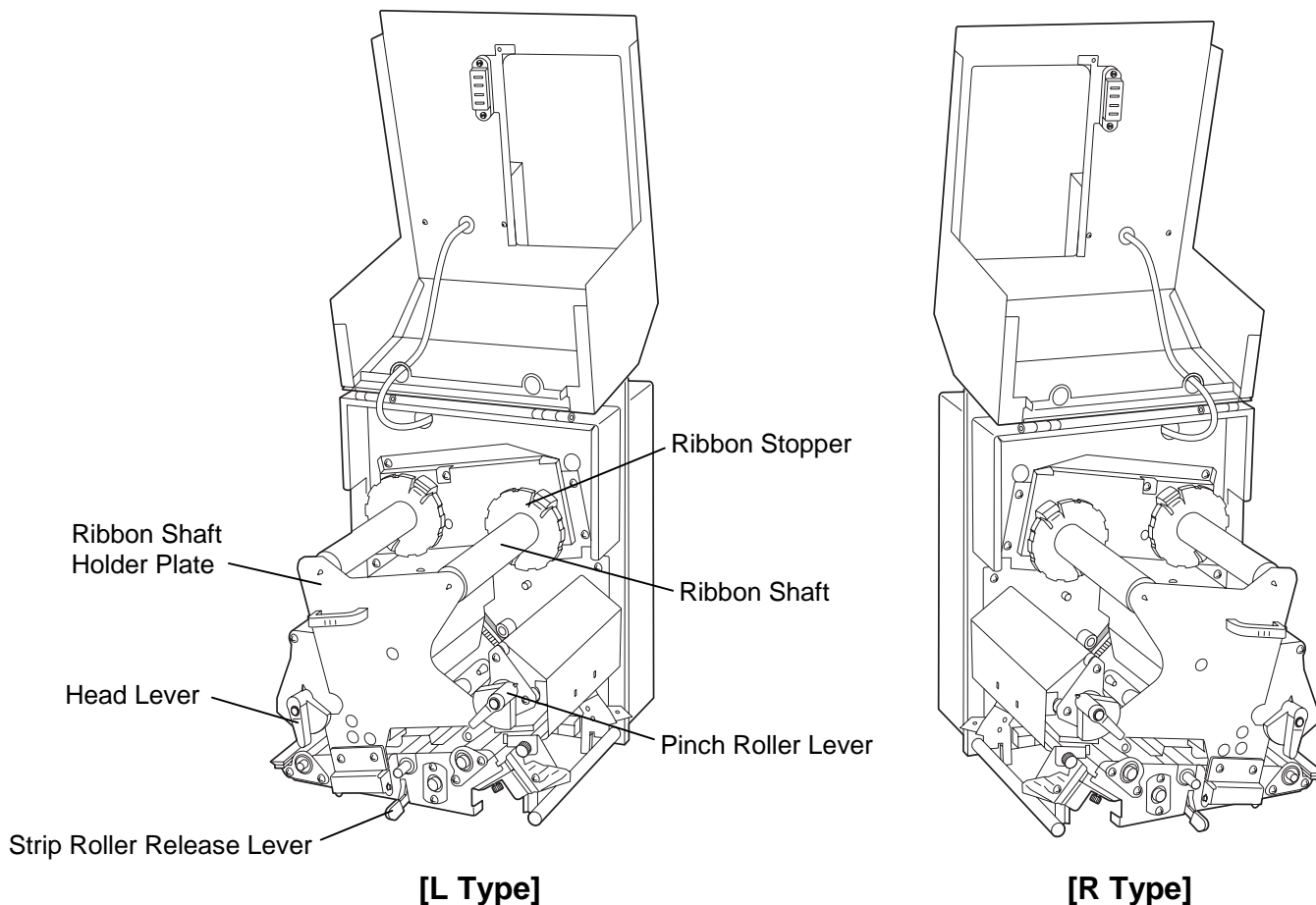

1.5.5 Operation Panel

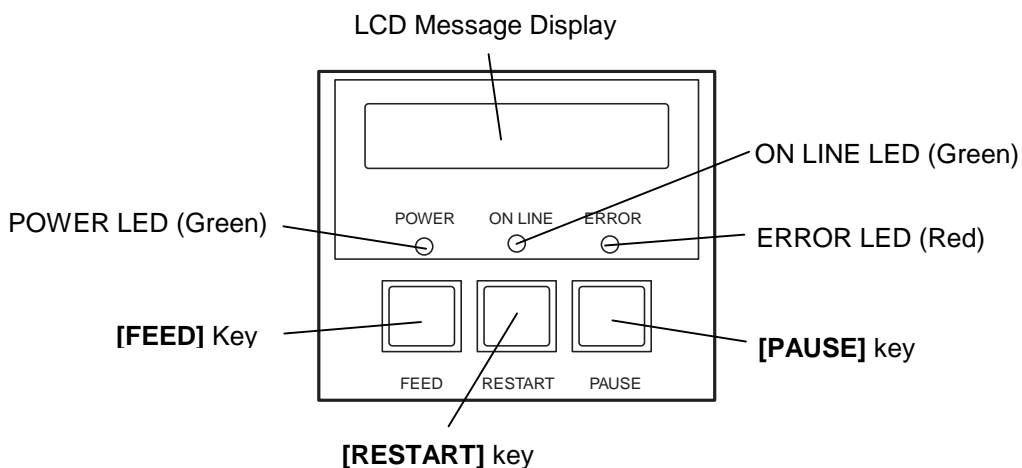

Please see Section 3.1 for further information about the Operation Panel.

NOTE:
 The illustrations used hereafter are of the L type, as the operating procedure is common to both L and R types.

1.6 Appearance of the Power Supply Unit

1.6.1 Dimensions

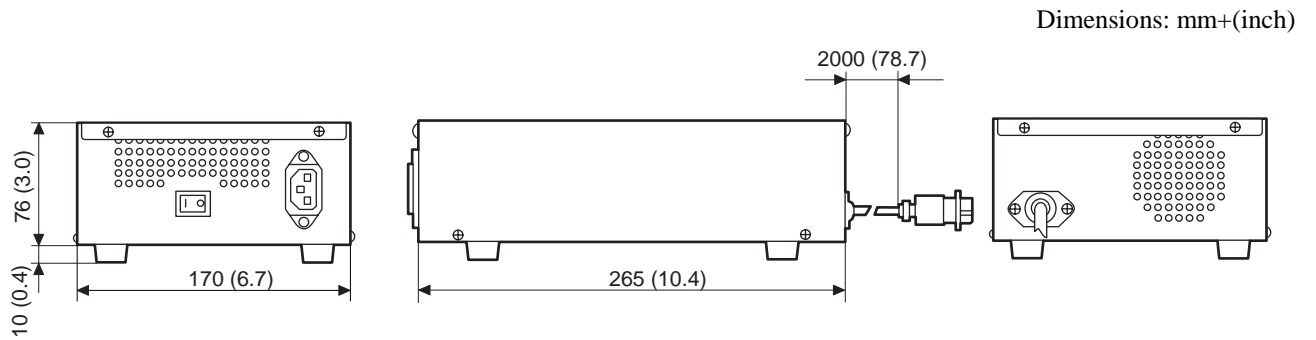

1.6.2 Front View

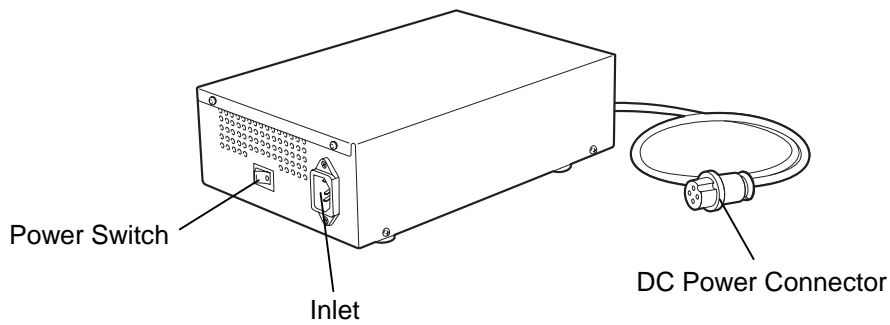

2. PRINTER SETUP

This section outlines the steps necessary to setup your B-492L/R printer prior to its operation. The section includes precautions, connecting cables, assembling accessories, loading media and ribbon, inserting an optional memory card, and performing a test print.

2.1 Precautions

- To insure the best operating environment, and to assure the safety of the operator and the equipment, please observe the following precautions.
- Operate the printer on a stable, level, operating surface in a location free from excessive humidity, high temperature, dust, vibration or direct sunlight.
- Keep your work environment static free. Static discharges can cause damage to delicate internal components.
- Make sure that the printer is connected to a clean source of AC Power and that no other high voltage devices that may cause line noise interference are connected to the same mains.
- Ensure that the printer is connected only to AC mains that has a proper ground (earth) connection.
- Only use the power cable provided with this unit to power it..
- Do not operate the printer with the cover open. Be careful not to allow fingers or articles of clothing to get caught into any of the moving parts of the printer.
- Make sure to turn off the printer power and to remove the power cord from the printer whenever working on the inside of the printer or when cleaning the printer.
- For best results, and longer printer life, use only TOSHIBA TEC recommended media and ribbons.
- Store the media and ribbons in accordance with their specifications.
- This printer mechanism contains high voltage components; therefore you should never remove any of the covers of the machine as you may receive an electrical shock. Additionally, the printer contains many delicate components that may be damaged if accessed by unauthorized personnel.
- Clean the outside of the printer with a clean dry cloth or a clean cloth slightly dampened with a mild detergent solution.
- Use caution when cleaning the thermal print head as it may become very hot while printing. Wait until it has had time to cool before cleaning. Use only the TOSHIBA TEC recommended print head cleaner to clean the print head.
- Do not turn off the printer power or remove the power plug while the printer is printing or while the ON LINE lamp is blinking.

2.2 Procedure before Operation

NOTE:

To communicate directly with a host computer, either an RS-232C cable or Centronics cable is required.

- (1) RS-232C cable: 9 pins
(do not use a null modem cable)
- (2) Centronics cable: 36 pins
- (3) Expansion I/O cable: 24 pins (Option)

NOTE:

Use of a Windows Driver will allow issuing media on the B-492L/R printer from a Windows application. The printer can also be controlled with its own programming commands. Please contact your TOSHIBA TEC reseller for the Interface/Communication Manual.

This section describes the outline of the printer setup.

1. Unpack the accessories and printer from the box.
2. Refer to Safety Precautions in this manual and set up the printer at a proper location.
3. Attach the fan filter to the rear of the printer. (Refer to Section 2.3.)
4. The host computer must have an available serial port, Centronics parallel port or a Ethernet (option) connection. (Refer to Section 2.4.)
5. Connect the DC power cord plug to the printer. Connect the AC power cord to the Power Supply Unit. (Refer to Section 2.5.)
6. Load the media in the printer. (Refer to Section 2.7.)
7. Adjust the position of the Feed Gap Sensor or Black Mark Sensor to match the media being used. (Refer to Section 2.7.)
8. Load the ribbon onto the Ribbon Shafts. (Refer to Section 2.8.)
9. Turn the Power ON. (Refer to Section 2.6.)
10. Set the threshold. (Refer to Section 5.4.)
11. Perform a test print. (Refer to Section 2.10 and Appendix 4.6.)
12. Install the Printer Drivers. (Refer to Section 6.)

2.3 Fitting the Fan Filter

When installing the printer, it is important to ensure that the fan filter is attached before using the printer.

The fan filter consists of 2 parts:

- (1) Filter Pad
- (2) Filter Retainer

To fit the fan filter, put the filter pad inside the filter retainer and simply press into place as shown in the diagram below, ensuring connecting pins are aligned with the connecting holes.

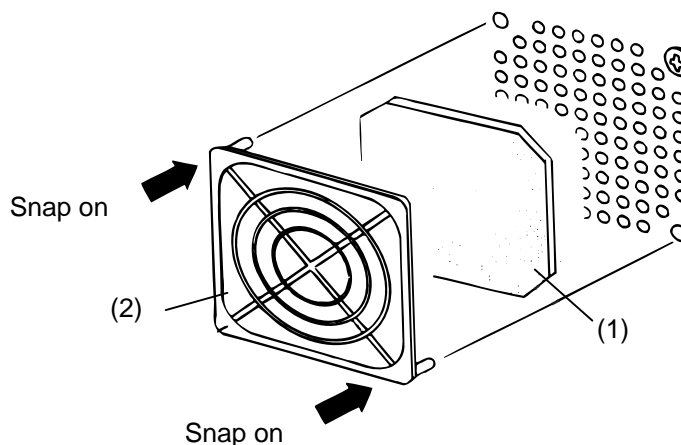

2.4 Connecting the Cables to Your Printer

The following paragraphs outlines how to connect the cables from the B-492L/R printer to your host computer, and will also show how to make cable connections to other devices such as the KB-80-QM keyboard, etc. Depending on the application software you use to print labels, there are two possibilities for connecting the printer to your host computer. These are:

- A serial cable connection between the printer's RS-232 serial connector and one of your host computer's COM ports (Refer to APPENDIX 3.)
- A parallel cable connection between the printer's standard parallel connector and your host computer's parallel port (LPT).
- An Ethernet connection using the optional PCMCIA interface board and LAN card (Refer to section 2.9)

The diagram below shows all the possible cable connections to the current version of the B-492L/R printer.

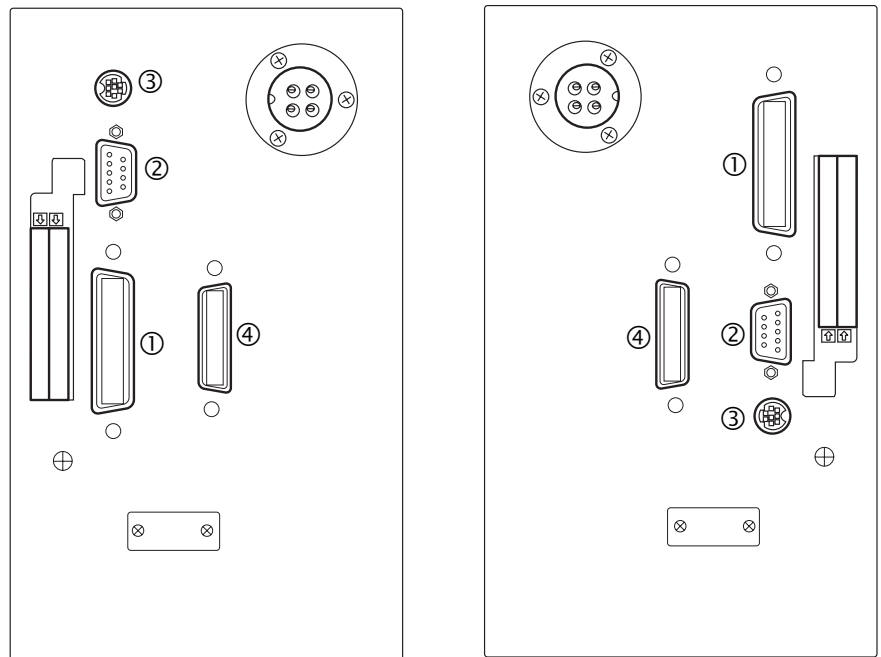

[L Type]

[R Type]

- ① Parallel Interface Connector (Centronics)
- ② Serial Interface Connector (RS-232C)
- ③ KB-80-QM Keyboard Interface Connector (Option)
- ④ Expansion I/O Interface Connector

2.5 Connecting the Power Cord

CAUTION!

1. Make sure that the printer power switch is turned to the off position before connecting the power cord to prevent possible electric shock or damage to the printer.
2. Use only the power cord supplied with the printer. Use of any other cord may cause electric shock or fire.
3. Connect the power cord to a supply outlet with a properly grounded (earthed) connection.

1. Connect the DC power cable from the DC Power Supply Unit to the printer.

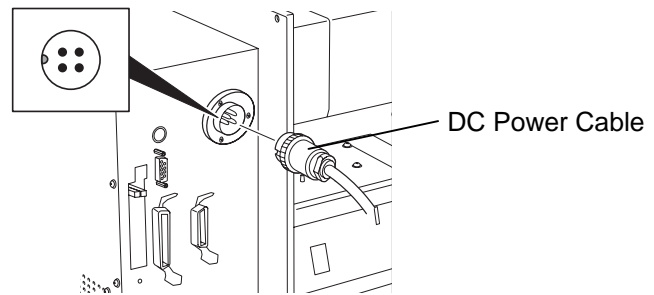

2. Make sure that the printer power switch is in the OFF (O) position.

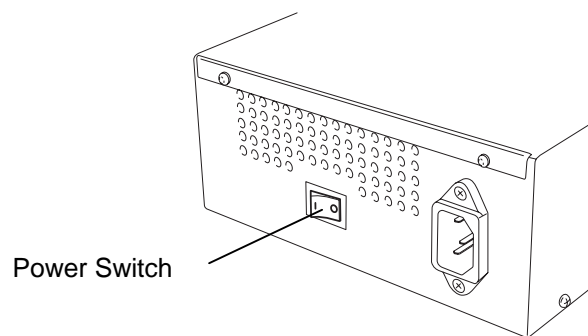

3. Connect the power cord to the Power Supply Unit as shown in the figure below.

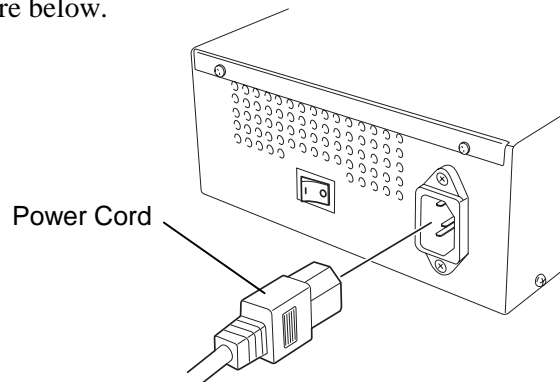

4. Plug the other end of the power cord into a grounded outlet as shown in the figure below.

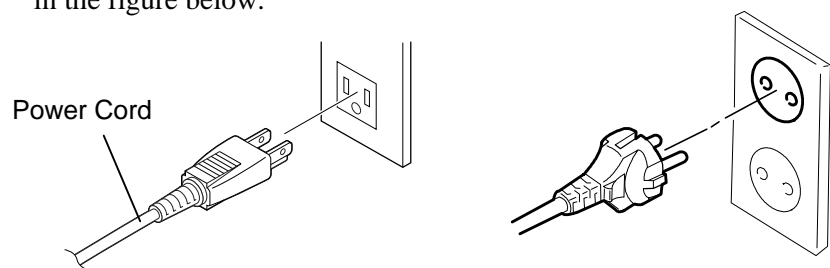

[QQ Type]

[QP Type]

2.6 Turning the Printer ON/OFF

When the printer is connected to a host computer it is good practice to turn the printer ON before turning on the host computer and to turn OFF the host computer before turning off the printer.

2.6.1 Turning ON the Printer

CAUTION!

Use the power switch to turn the printer On/Off. Plugging or unplugging the power cord to turn the printer On/Off may cause fire, an electric shock, or damage to the printer.

NOTE:

If a message other than ON LINE appears on the display or the ERROR LED lamp is illuminated, go to Chapter 5.1, Error Messages.

1. To turn ON the printer power, press the power switch as shown in the diagram below. Note that (|) is the power ON side of the switch.

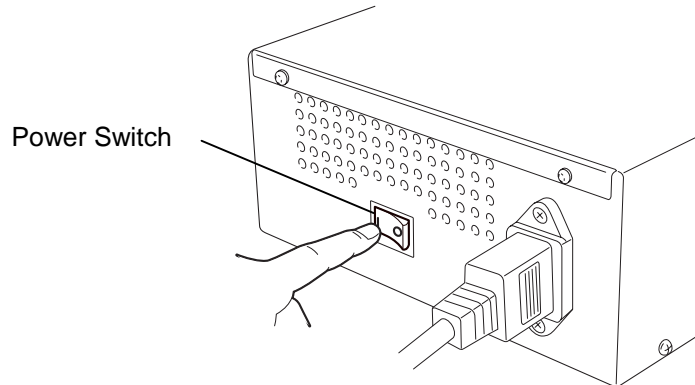

2. Check that the message ON LINE appears on the LCD Display and that the ON LINE and POWER LED lights are illuminated

2.6.2 Turning OFF the Printer

CAUTION!

1. Do not turn off the printer power while the media is being printed as this may cause a paper jam or damage to the printer.
2. Do not turn off the printer power while the ON LINE light is blinking as this may cause damage to your host computer.

1. Before turning off the printer power switch verify that the ON LINE message is on the LCD Message Display and that the ON LINE LED light is on and not flashing.
2. To turn OFF the printer power press the power switch as shown in the diagram below. Note that (O) is the power OFF side of the switch.

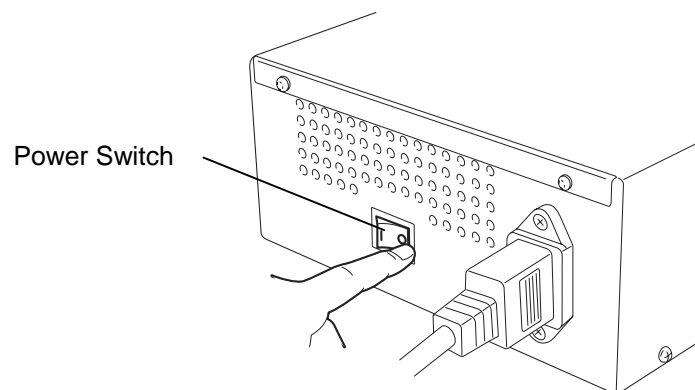

2.7 Loading the Media

This section describes in detail how to load the media.

WARNING!

1. Do not touch any moving parts. To reduce the risk of fingers, jewellery, clothing, etc. being drawn into the moving parts, be sure to load the media once the printer has stopped moving completely.
2. To avoid injury, be careful not to trap your fingers while opening or closing the cover.
3. Be sure to open the top cover fully, otherwise the top cover may close, causing injury.

1. Open the top cover and turn the head lever and pinch roller lever to position ②, then open the ribbon shaft holder plate.

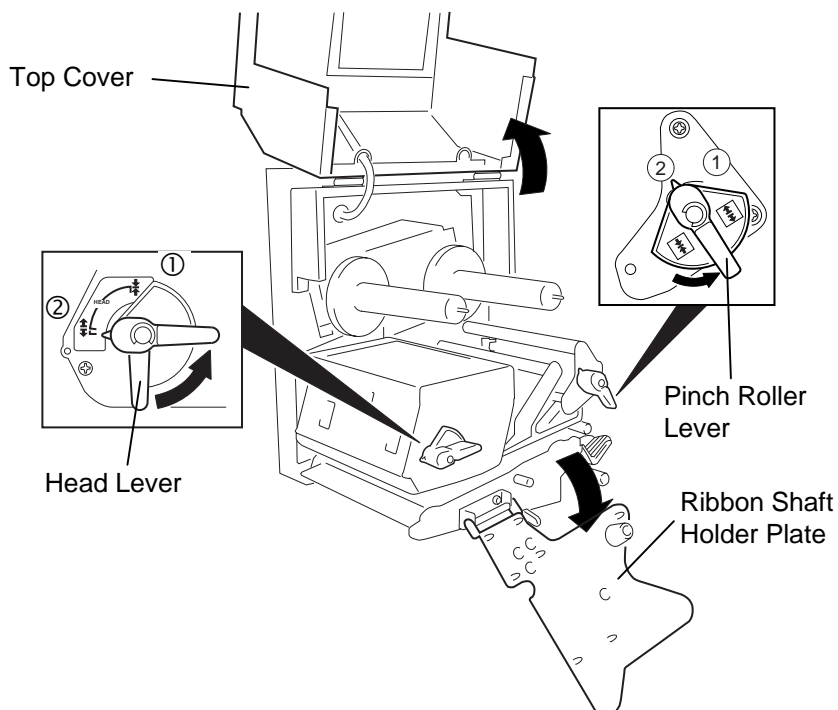

NOTES:

1. When the head lever is turned to position ②, the print head is raised.
2. When the pinch roller lever is turned to position ②, the pinch roller is raised.
3. To enable printing the head lever and the pinch roller lever must be set to position ①. This ensures that the print head and the pinch roller are closed.

2. Insert the media into the printer from the side as shown in the figure below. Ensure that the media is positioned in the black mark/feed gap sensor.

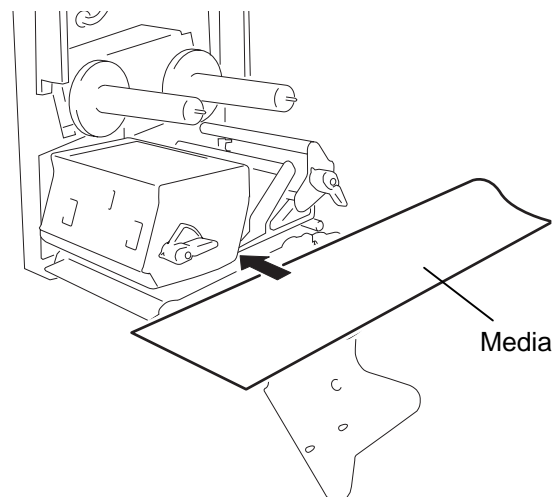

2.7 Loading the Media (Cont.)

NOTE:

The media guide should be positioned so that the media can feed smoothly.

3. Open the paper entry guide.
4. Loosen the locking screw of the right side of the media guide and open the media guides.
5. Insert each edge of the media into the paper holders of the media guides by adjusting the media guides positions to the media width. Then tighten the locking screw.

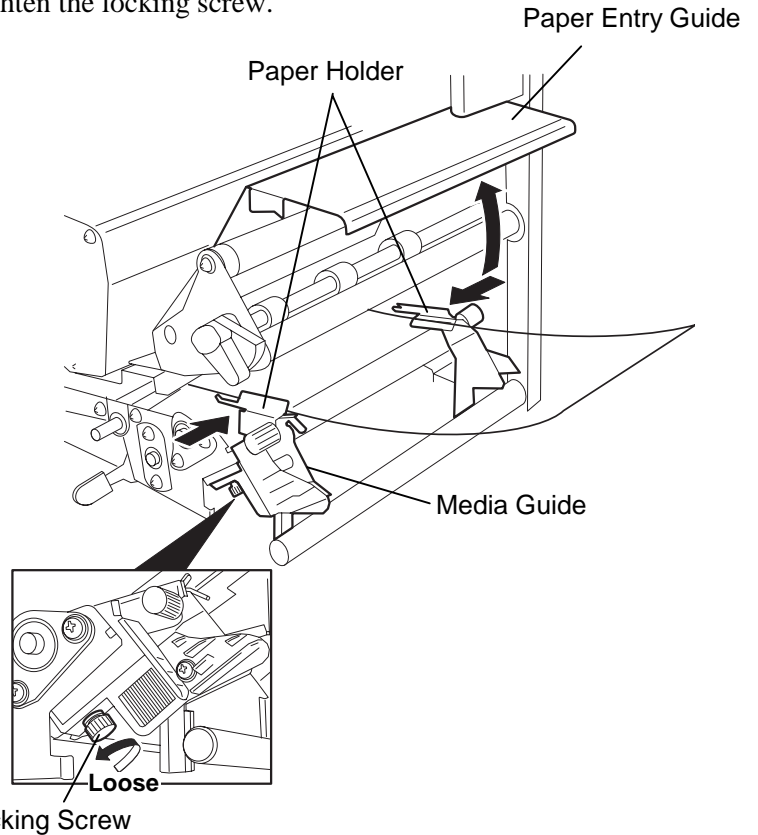

6. Pass the media straight from the paper holders to paper outlet. The media should be centred on the strip plate, otherwise skew feeding or a paper jam may occur. Check that the media is positioned so that the distances from the media edge to the end of the scale marked on the strip plate (Distances A and B in the figure below.) are almost equal.

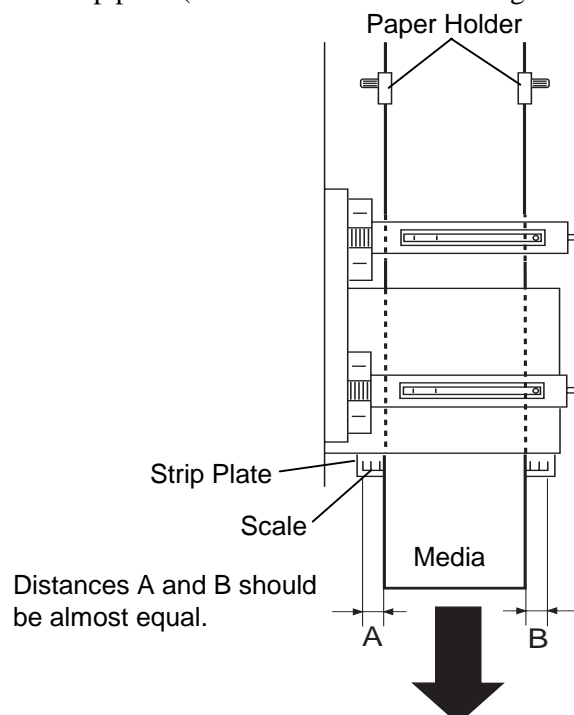

2.7 Loading the Media (Cont.)

NOTES:

1. Turning the adjusting knob to the right will move the sensor towards the center of the media while turning it to the left will move it away from the center of the media.
2. Be sure to set the black mark sensor to detect the center of the black mark, otherwise a paper jam or no paper error may occur.

7. After loading the media, it may be necessary to set the media sensors used to detect the print start position of the labels. Set the black mark/feed gap sensor to the correct position by turning the adjusting knob.

Setting the feed gap sensor position

Turn the adjusting knob to move the feed gap sensor to the centre of the labels to detect the gap between labels. If the labels are round, set the sensor to detect the area of the shortest distance between the labels. (← indicates the position of the feed gap sensor).

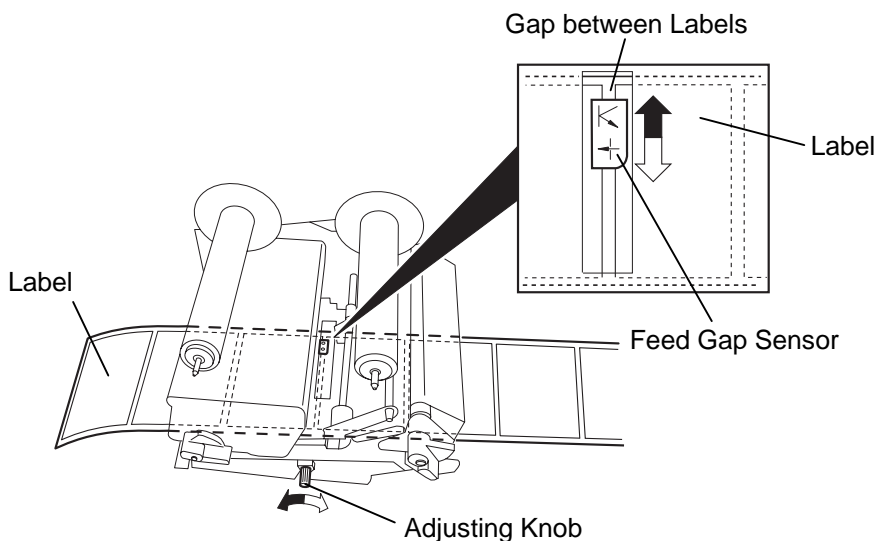

Setting the black mark sensor position

- (1) Pull about 500 mm of media out of the front of the printer, turn the media back on itself and feed it under the print head past the sensor so that the black mark can be seen from above.
- (2) Turn the adjusting knob to move the black mark sensor so that it is in line with the center of the black mark on the media. (← indicates the position of the black mark sensor.)

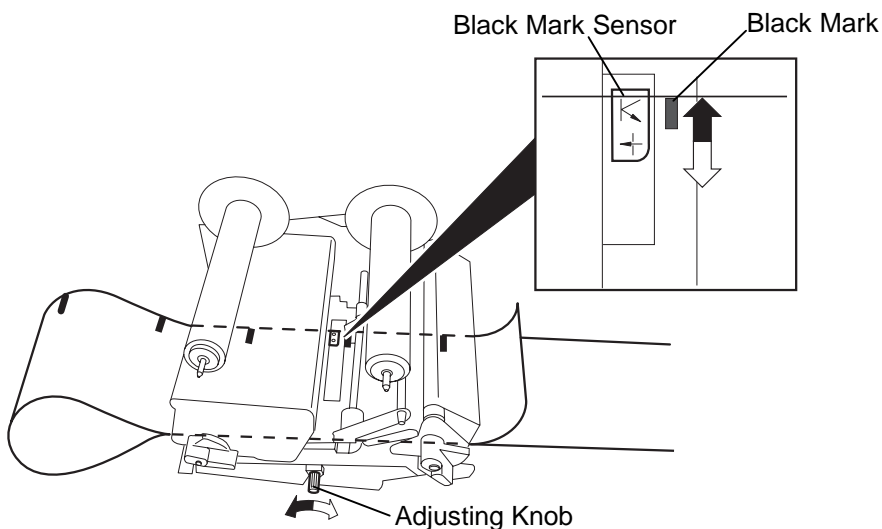

2.7 Loading the Media (Cont.)

CAUTION!

To separate the printed media from the media roll in batch mode, be sure to tear off the media at the strip shaft or cut the media past the strip shaft. However, if you tear off the media at the print head by mistake, be sure to feed one label (10 mm or more) with the **[FEED]** key prior to next issue. Failure to do this may cause a paper jam.

8. There are two issue modes available on this printer.

Batch mode:

In the batch mode, the media is continuously printed and fed until the number of issues specified in the label issue command has been printed.

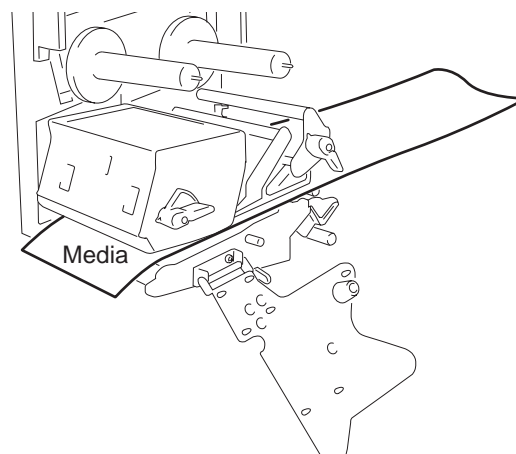

If the loaded media is direct thermal media (a chemically treated surface), the media loading procedure is now complete. Close the ribbon shaft holder plate, and turn the head lever and the pinch roller lever to position ① to close. Then, close the top cover.

If the media is a standard media, it is also necessary to load a ribbon. Refer to the section, 2.8 Loading the Ribbon.

Strip mode:

In strip mode, as each label is printed the backing paper is automatically removed from the label at the strip plate.

- (1) Set the ribbon shaft holder plate, and turn the head lever and the pinch roller lever to position ① to close.
- (2) Remove enough labels from the leading edge of the media to leave 500 mm of backing paper free.
- (3) Push the pinch roller release lever toward the front of the printer to release the strip pinch roller unit.

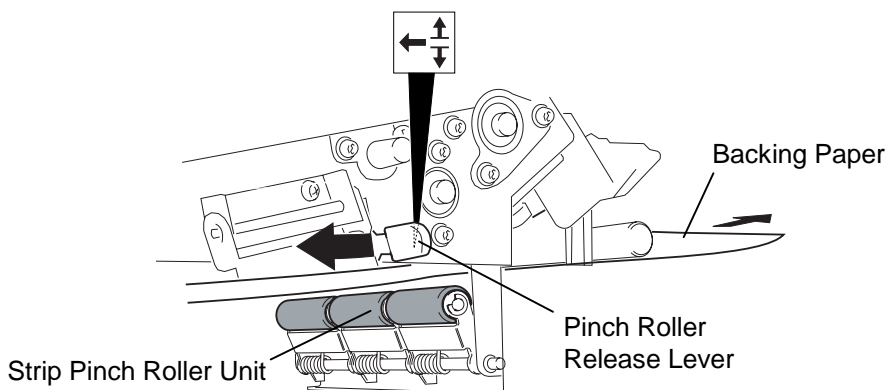

2.7 Loading the Media (Cont.)

- (4) Pass the backing paper under the strip plate and above the strip pinch roller.
- (5) While pulling the backing paper push up the strip pinch roller until it locks into position.

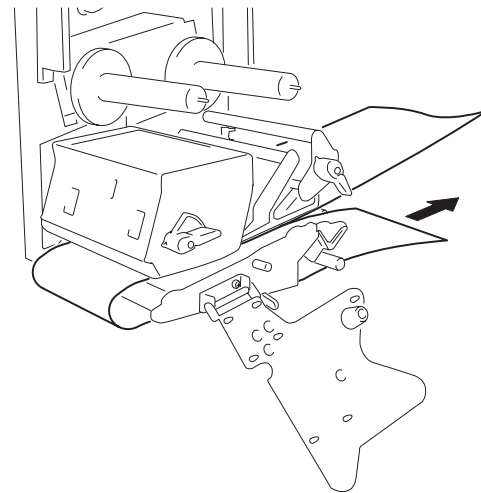
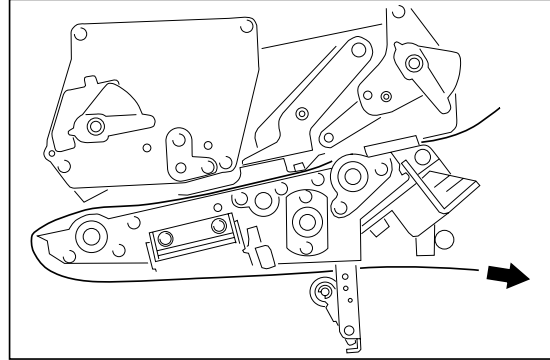

- (6) If the loaded media is direct thermal media (a chemically treated surface), the media loading procedure is now complete. Close the ribbon shaft holder plate, and turn the head lever and the pinch roller lever to position ① to close. Then, close the top cover. If the media is a standard media, it is also necessary to load a ribbon. Refer to the following section, 2.8 Loading the Ribbon.

2.8 Loading the Ribbon

WARNING!

1. Do not touch any moving parts. To reduce the risk of fingers, jewellery, clothing, etc. being drawn into the moving parts, be sure to load the ribbon once the printer has stopped moving completely.
2. To avoid injury, be careful not to trap your fingers while opening or closing the cover.
3. Be sure to open the top cover fully, otherwise the top cover may close, causing injury.

1. Grasp the tabs on the top and bottom of the ribbon stoppers and move the ribbon stoppers back to the end of the shaft.

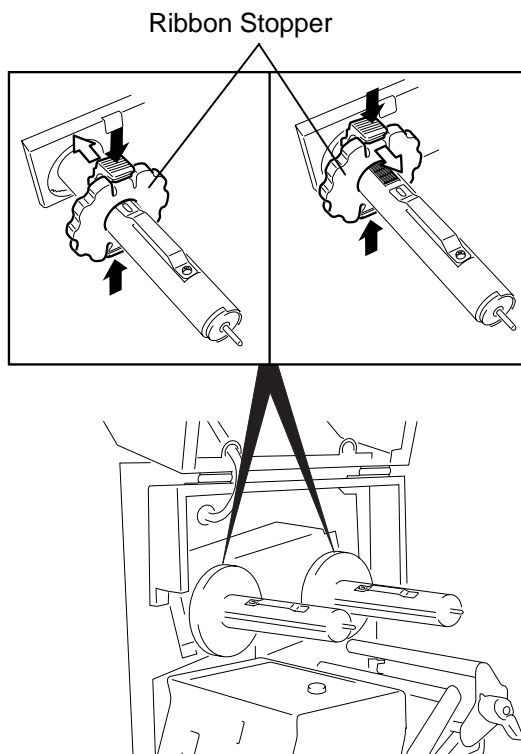

2. Leaving plenty of slack between the ribbon spools, place the ribbon onto the ribbon shafts as shown below. When the ribbon is fitted, it must be positioned in the ribbon sensor.

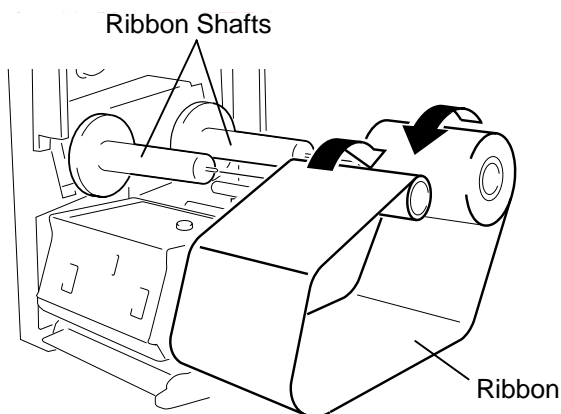

NOTE:

The ribbon sensor is mounted on the rear of the printer block to detect a ribbon end. When a ribbon end is detected, "NO RIBBON" message will appear on the display and the ERROR LED will illuminate.

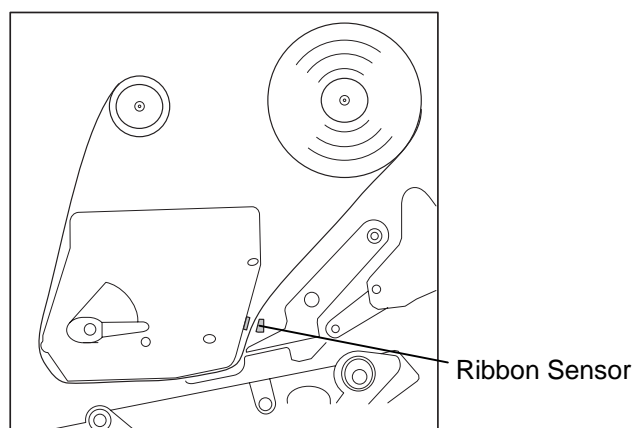

2.8 Loading the Ribbon (Cont.)

3. Slide the ribbon stoppers along the ribbon shafts to a position where the ribbon is centered when fitted.
4. Take up any slack in the ribbon. Take the leading tape onto the ribbon take-up roll until the ink ribbon can be seen from the front.
5. Set the ribbon shaft holder plate aligning its holes with the ribbon shafts.
6. Turn the head lever and the pinch roller lever to position ① to close the print head and the pinch roller.
7. Close the top cover.

2.9 Inserting the Optional PCMCIA Cards

CAUTION!

1. To protect PC cards, discharge static electricity from your body by touching the metal cabinet of the printer before touching the card.
2. Before inserting or removing a PCMCIA card make sure that the printer's power is turned off.
3. Be sure to protect PCMCIA Cards when not in use by putting them into their protective covers.
4. Do not subject the card to any shocks or excessive force nor expose the card to extremes in temperature or humidity
5. The card may be inserted into the slot halfway even in the wrong orientation. However, the slot is safety designed so that the card will not seat against the connector pins.

When the optional PCMCIA interface board is installed in the B-492L/R printer, there will be two PCMCIA slots available as shown in the figure below. This allows the use of Flash Memory Type Cards or I/O Cards such as LAN Cards.

1. Make sure that the printer's power switch is in the OFF position.
2. Hold the PCMCIA Card so that the side printed with the model name faces right. Insert the card into the proper slot until the Eject Button pops out.

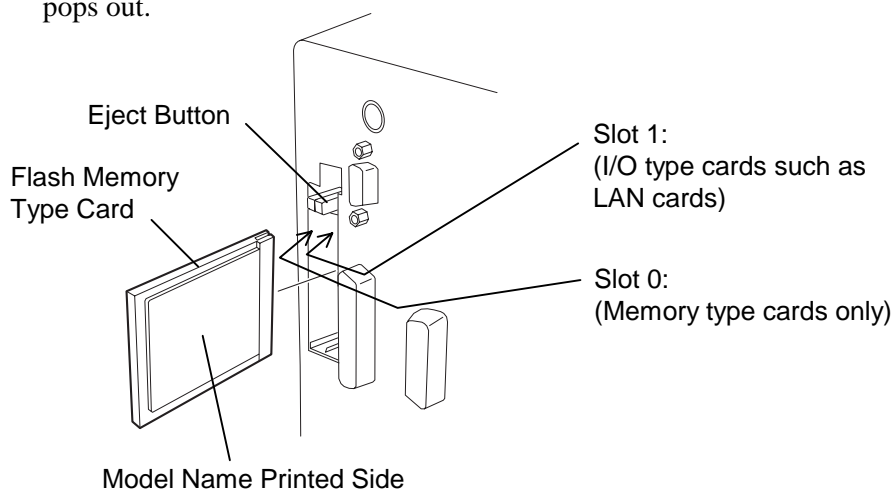

2.9 Inserting the Optional PCMCIA Cards (Cont.)

3. The following PCMCIA cards can be used.

Type	Maker	Description	Remarks
ATA Card	San Disk Hitachi	A card conforming to the PC card ATA standard	-----
LAN Card	3 COM	Ether Link III 3C589D PC card	Install into the slot (1) only. (This card installed into the slot (0) will not work.)
		Megahertz® 10M bps LAN PC Card 3CCE589ET Series	
Flash Memory Card	Maxell	EF-1M-TB [AA]	Capacity: 1MB
	Mitsubishi	MF-81M1-GBDAT01	Read only
	Maxell	EF-4M-TB [CC]	Capacity: 4MB
		EF-4M-TB [DC]	Readable/writable
	Centennial Technologies INC.	FL04M-15-11119-03	Capacity: 4MB Read only
	INTEL	IMC004FLSA	
	Simple TECHNOLOGY	STI-FL/4A	
	Mitsubishi	MF84M1-G7DAT01	
	PC Card KING MAX	FJN-004M6R	
PC Card	FJP-004M6R		

2.10 Test Print

A print test should be performed to check that the printer is operating correctly. During this test, the printer will first issue a blank page of media to allow the sensors to detect the Black Mark or Label Gap. Then it will print five pages of slanted lines followed by five pages of sample bar codes then finally by printing five pages that contain characters of various sizes.

For the test print procedure, please refer to Appendix 4.6 Test Print.

3. ON LINE MODE

This chapter describes usage of the keys on the Operation Panel in On Line Mode.

When the printer is in On Line Mode and connected to a host computer, the normal operation of printing images on labels can be achieved.

3.1 Operation Panel

The figure below shows the Operation Panel and key functions..

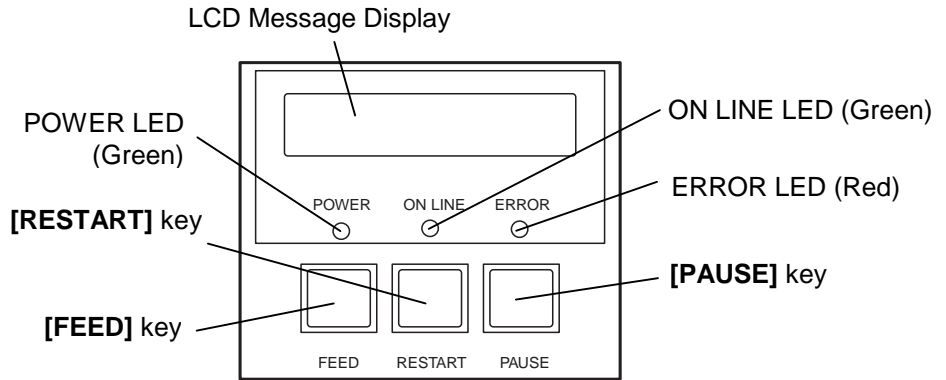

The LCD Message Display shows messages to indicate the printer's current status. Up to 16 characters can be displayed on this line.

There are three LED lights on the Operation Panel.

LED	Illuminates when...	Flashes when...
POWER	The printer is turned on.	-----
ON LINE	The printer is ready to print.	The printer is communicating with your computer.
ERROR	Any error occurs on the printer.	-----

There are three keys on the Operation Panel.

PAUSE	Used to stop printing temporarily.
RESTART	Used to restart printing.
FEED	Used to feed the media.

NOTE:

Use the **[RESTART]** key to resume printing after a pause, or after clearing an error.

3.2 Operation

When the printer is turned on, the "ON LINE" message appears on the LCD message display. It is displayed during standby or normal printing.

1. The printer is turned on, standing by, or printing.

ON LINE

2. If any error occurs during printing, an error message appears. The printer stops printing automatically. (The number on the right hand side shows the remaining number of labels to be printed.)

NO PAPER 125

3. To clear the error, press the **[RESTART]** key. The printer resumes printing.

ON LINE

4. If the **[PAUSE]** key is pressed during printing, the printer stops printing temporarily. (The number on the right hand side shows the remaining number of labels to be printed.)

PAUSE 52

5. When the **[RESTART]** key is pressed, the printer resumes printing.

ON LINE

4. MAINTENANCE

WARNING!

1. Be sure to turn OFF the power of the power supply unit before performing maintenance. Failure to do this may cause an electric shock.
2. To avoid injury, be careful not to pinch your fingers while opening or closing the cover and print head block.
3. Be careful when handling the print head as it becomes very hot immediately after printing. Allow it to cool before performing any maintenance.
4. Do not pour water directly onto the printer.

This chapter describes how to perform routine maintenance.

To ensure the continuous high quality operation of your B-492L/R, you should perform a regular maintenance routine. For high throughput it should be done on a daily basis. For low throughput it should be done on a weekly basis.

4.1 Cleaning

To maintain the printer performance and print quality, please clean the printer regularly, or whenever the media or ribbon is replaced.

4.1.1 Print Head/Platen

CAUTION!

1. Do not allow any hard objects to touch the print head or platen, as this may cause damage to them.
2. Do not use any volatile solvents including thinner and benzene, as this may cause discoloration of the cover, print failure, or breakdown of the printer.
3. Do not touch the print head element with bare hands, as static may damage the print head.

1. Turn the power off.
2. Open the top cover.
3. Turn the head lever and pinch roller lever to position ②, then open the ribbon shaft holder plate.
4. Remove the ribbon and media.
5. Clean the element of the print head with the print head cleaner or a soft cloth slightly moistened with ethyl alcohol or isopropyl alcohol.

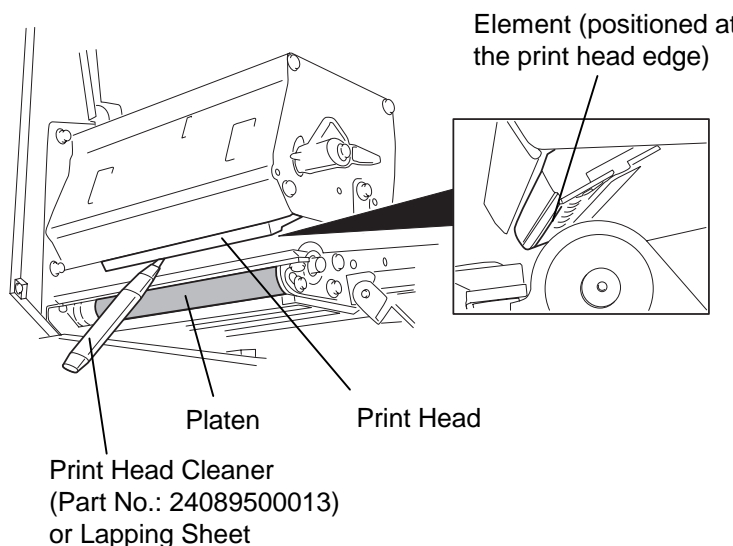

4.1.1 Print Head/Platen (Cont.)

NOTES:

1. A print head cleaner or lapping sheet is not enclosed with the printer. Please use a TEC approved print head cleaner or lapping sheet which can be purchased from an authorised TOSHIBA TEC service representative.
2. Do not rub the print head element with a lapping sheet excessively, or the print head life will be shortened.
3. When purchasing a lapping sheet locally, it should meet the following specifications.
 Product name: Imperial lapping film sheet
 Model: #4000 (Grain size: 3 μ m, Abrasive coating: Aluminum oxide, Backing material: 3MIL)
 Maker: Sumitomo 3M

6. When you are using some semi-resin ribbons the print head element can still be stained with burned ribbon particles even after performing the above-mentioned cleaning. In this case wipe the print head element from end to end in both directions 4 – 5 times with a 30 mm by 30 mm piece of lapping sheet.
7. Wipe the platen with a soft cloth moistened with alcohol.

4.1.2 Media Guide Plate/ Pinch Roller/Sensors

1. Carefully pull out the media guide plate from the two guide shafts.
2. Wipe the bottom of the media guide with a cloth moistened with alcohol.

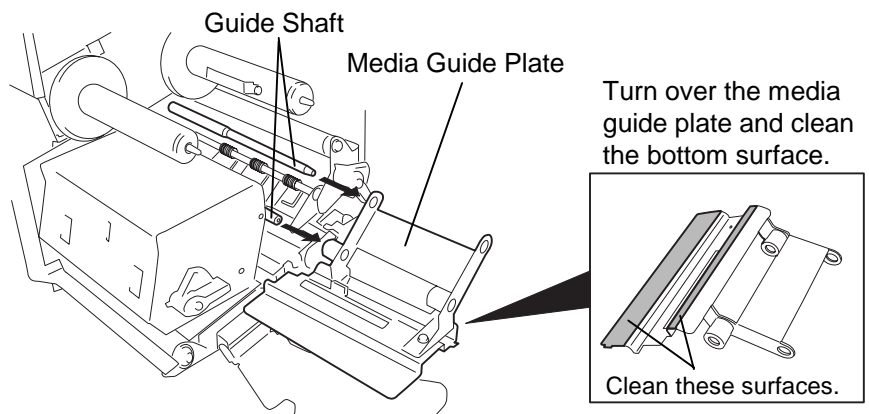

4.1.2 Media Guide Plate/ Pinch Roller/Sensors (Cont.)

- Remove the locking screw to detach the paper guide B from the printer.

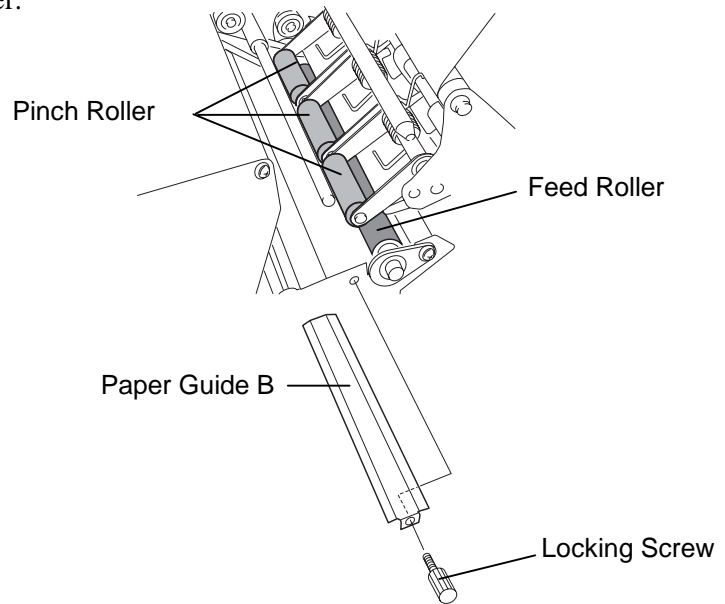

- Push the pinch roller release lever toward the front of the printer to release the strip pinch roller unit.
- Wipe the feed roller and pinch rollers with a soft cloth moistened with alcohol.
- Remove dust or paper particles from the black mark and feed gap sensors using an air blower.

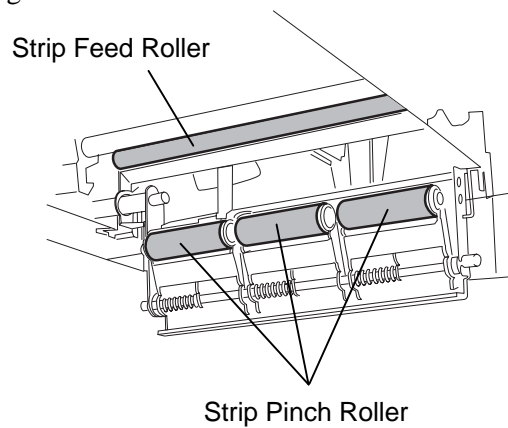

4.1.3 Paper Holder

1. Open the paper entry guide.
2. Loosen the locking screw and move the media guides toward the center.
3. Remove the set screws to detach both paper holders' upper plates.
4. Wipe the paper holders' upper and lower plates with a soft cloth moistened with alcohol.

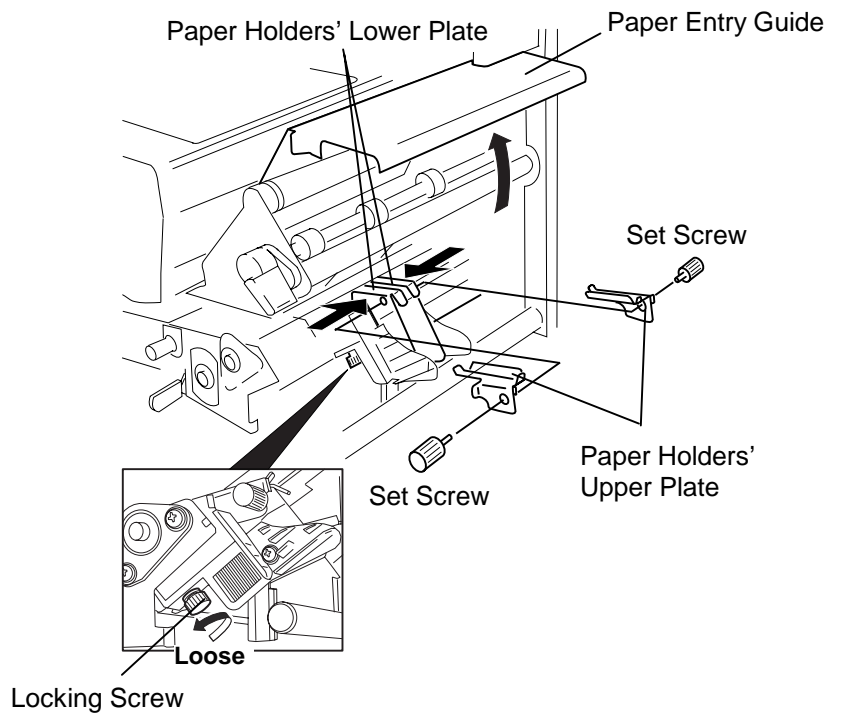

4.1.4 Covers and Panels

CAUTION!

Do not use any volatile solvents including thinner and benzene, as this may cause discoloration or distortion of the cover.

Wipe the Cover and Operation Panel with a dry soft cloth. Wipe off dirt with a soft cloth slightly moistened with water.

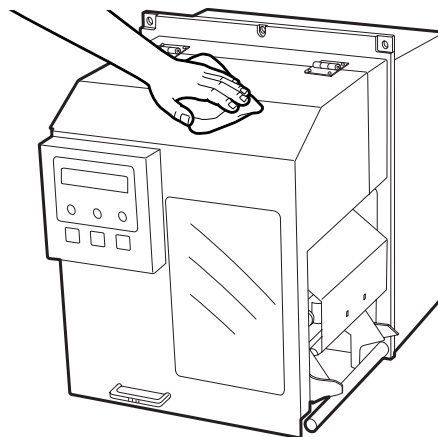

4.2 Care/Handling of the Media and Ribbon

CAUTION!

Be sure to carefully review and understand the Supply Manual. Use only media and ribbons which meet specified requirements. Use of non-specified media and ribbons may shorten the head life and result in problems with bar code readability or print quality. All media and ribbons should be handled with care to avoid any damage to the media, ribbons or printer. Read the guideline in this section carefully.

- Do not store media or ribbon for longer than the manufacturer's recommended shelf life
- Store media rolls on the flat end. Do not store them on the curved sides as this might flatten that side causing erratic media advance and poor print quality.
- Store the media in plastic bags and always reseal after opening. Unprotected media can get dirty and the extra abrasion from the dust and dirt particles will shorten the print head life.
- Store the media and ribbon in a cool, dry place. Avoid areas where they would be exposed to direct sunlight, high temperature, high humidity, dust or gas.
- The thermal paper used for direct thermal printing must not have specifications which exceed Ca^{2+} , K^+ , Na^+ 800 ppm, and Cl^- 600 ppm.
- Some ink used on pre-printed media may contain ingredients which shorten the print head's product life. Do not use labels pre-printed with ink which contain hard substances such as carbonic calcium (CaCO_3) and kaolin (Al_2O_3 , 2SiO_2 , $2\text{H}_2\text{O}$).

For further information, please contact your local distributor or your media and ribbon manufacturers.

5. TROUBLESHOOTING

This chapter lists the error messages, possible problems, and their solutions.

WARNING!

If a problem cannot be solved by taking actions described in this chapter, do not attempt to repair the printer. Turn off and unplug the printer. Then contact an authorized TOSHIBA TEC service representative for assistance.

5.1 Error Messages

NOTES:

- If an error is not cleared by pressing the **[RESTART]** key, turn the printer off and then on.
- After the printer is turned off, all print data in the printer is cleared.
- "****" indicates the remaining number of labels to be printed. Up to 9999 (pieces)

Error Messages	Problems/Causes	Solutions
HEAD OPEN	The print head block is opened in Online Mode.	Close the print head block. Then press the [RESTART] key.
HEAD OPEN ****	Feeding or printing has been attempted with the Print Head Block open.	Close the print head block. Then press the [RESTART] key.
COMMS ERROR	A communication error has occurred.	Make sure the interface cable is correctly connected to the printer and the host, and the host is turned on. Then press the [RESTART] key.
PAPER JAM ****	<ol style="list-style-type: none"> 1. The media is jammed in the media path. The media is not fed smoothly. 2. A wrong media sensor is selected for the media being used. 3. The Black Mark Sensor is not correctly aligned to the Black Mark on the media. 4. Size of the loaded media is different from the programmed size. 5. The Feed Gap Sensor cannot distinguish the print area from a label gap. 	<ol style="list-style-type: none"> 1. Remove the jammed media, and clean the platen. Then reload the media correctly. Finally press the [RESTART] key. 2. Turn the printer off and then on. Then select the media sensor for the media being used. Finally resend the print job. 3. Adjust the sensor position. Then press the [RESTART] key. 4. Replace the loaded media with one that matches the programmed size then press the [RESTART] key, or turn the printer off and then on, select a programmed size that matches the loaded media. Finally resend the print job. 5. Refer to Section 6.4 to set the threshold. If this does not solve the problem, turn off the printer, and call an authorized service representative.
NO PAPER ****	<ol style="list-style-type: none"> 1. The media has run out. 2. The media is not loaded properly. 3. The media is slack. 	<ol style="list-style-type: none"> 1. Load new media. Then press the [RESTART] key. 2. Reload the media correctly. Then press the [RESTART] key. 3. Take up any slack in the media.
RIBBON ERROR ****	The ribbon is not fed properly.	Remove the ribbon, and check the status of the ribbon. Replace the ribbon, if necessary. If the problem is not solved, turn off the printer, and call an authorized service representative.

5.1 Error Messages (Cont.)

Error Messages	Problems/Cause	Solutions
NO RIBBON ****	The ribbon has run out.	Load a new ribbon. Then press the [RESTART] key.
EXCESS HEAD TEMP	The print head has overheated.	Turn off the printer, and allow it to cool down (for about 3 minutes). If this does not solve the problem, call a TOSHIBA TEC authorized service representative.
HEAD ERROR	There is a problem with the Print Head.	Replace the Print Head. Then press the [RESTART] key.
COVER OPEN ****	Media feed or print operation is attempted with the top cover opened.	Close the top cover, then press the [RESTART] key.
PINCH OPEN ****	Media feed or print operation is attempted with the pinch roller raised.	Set the pinch roller, then press the [RESTART] key.
PEEL OPEN ****	Media feed or print operation is attempted with the strip pinch roller unit opened.	Close the strip pinch roller unit, then press the [RESTART] key.
GUIDE OPEN ****	Media feed or print operation is attempted with the media guide plate removed.	Set the media guide plate, then press the [RESTART] key.
Other error messages	A hardware or software problem may have occurred.	Turn the printer off and then on. If this does not solve the problem, turn off the printer again, and call a TOSHIBA TEC authorized service representative.

5.2 Possible Problems

This section describes problems that may occur when using the printer, and their causes and solutions.

Possible Problems	Causes	Solutions
The printer will not turn on.	<ol style="list-style-type: none"> 1. The AC Power Cord or DC Power Cord is disconnected. 2. The AC outlet is not functioning correctly. 3. The fuse has blown, or the circuit breaker has tripped. 	<ol style="list-style-type: none"> 1. Plug in the AC Power Cord or DC Power Cord. 2. Make sure that the power is supplied using another electric appliance. 3. Check the fuse or breaker.
The media is not fed.	<ol style="list-style-type: none"> 1. The media is not loaded properly. 2. The printer is in an error condition. 	<ol style="list-style-type: none"> 1. Load the media properly. 2. Solve the error in the Message Display. (See Section 5.1 for more detail.)
Nothing is printed on the media.	<ol style="list-style-type: none"> 1. The media is not loaded properly. 2. The ribbon is not loaded properly. 3. A print head is not installed properly. 4. The ribbon and media are not matched. 	<ol style="list-style-type: none"> 1. Load the media properly. 2. Load the ribbon properly. 3. Install the Print Head properly. Close the Print Head Block. 4. Select an appropriate ribbon for the media type being used.
The printed image is blurred.	<ol style="list-style-type: none"> 1. The ribbon and media are not matched. 2. The Print Head is not clean. 	<ol style="list-style-type: none"> 1. Select an appropriate ribbon for the media type being used. 2. Clean the print head using a Print Head Cleaner.

5.3 Removing Jammed Media

CAUTION!

Do not use any tool that may damage the print head.

This section describes in detail how to remove jammed media from the printer.

1. Open the top cover.
2. Turn the head lever and the pinch roller lever to position ②, then open the ribbon shaft holder plate.
3. Pull out the media guide plate from the printer side.
4. Remove the ribbon and media.
5. Remove the jammed media from the printer. **DO NOT USE** any sharp implements or tools as these could damage the printer.

5.4 Threshold Setting

NOTES:

1. If the **[PAUSE]** key is released within 3 seconds while in the pause state, the paper will not feed.
2. Failure to feed more than 1.5 labels may result in an incorrect threshold setting.
3. While the Print Head Block is raised, the **[PAUSE]** key does not work.
4. A paper end error cannot be detected during paper feed.
5. Selecting the Transmissive Sensor (for pre-printed labels) within software commands allows the printer to detect the proper print start position even when using pre-printed labels.
6. If using the transmissive sensor and the printer continues to print out of position even after setting the threshold, adjust the Feed Gap Sensor in the system mode. Reset the threshold again. Make sure that the Transmissive Sensor (for pre-printed labels) is selected in the feed and issue commands.

To maintain a constant print position the printer uses the Transmissive Sensor to detect the gap between labels by measuring the amount of light passing through the media. When the media is pre-printed, darker (or more dense) inks can interfere with this process causing paper jam errors. To get around this problem a minimum threshold can be set for the sensor in the following way.

■ Threshold setting procedure

1. Turn the power ON. The printer is in stand by mode.

ON LINE

2. Load the media.
3. Press the **[PAUSE]** key.

PAUSE

4. The printer enters the pause mode.
5. Press and hold the **[PAUSE]** key for at least 3 seconds in the pause state.

TRANSMISSIVE

6. The sensor type is displayed.
7. Select the sensor to be adjusted by pressing the **[FEED]** key.

REFLECTIVE

Black Mark Sensor

↑
[FEED] key
↓

TRANSMISSIVE

Feed Gap Sensor

5.4 Threshold Setting (Cont.)

8. Press and hold the **[PAUSE]** key until more than 1.5 labels have been issued.
The media will continue to be fed until the **[PAUSE]** key is released.
(Threshold setting for the selected sensor is completed by this operation.)

PAUSE

9. Press the **[RESTART]** key.

ON LINE

10. The printer is in stand-by.

11. Send an issue command from the PC to the printer.

ON LINE

6. PRINTER OPERATION

This section provides a functional overview of how the printer receives print data from your host computer and how it will operate in the various operating conditions. This section also shows you how to install the TEC Printer Drivers into your computer.

6.1 Overview

Labels will be created on the host computer connected to your printer, using either a commercially available label creation program or using the TEC Command Program Language. The label information sent from your host computer will consist of a series of commands that inform the printer of the labels size, layout, orientation, and number of copies to print and will also contain the print data including scaleable text, graphics, and bar codes. The printer electronics will decode the commands and manipulate the data to create a bit graphic image of the label that will be stored in the printer's memory. The printer electronics will then transfer the image as a series of dots, one line at a time, to the thermal print head.

The thermal print head consists of a line of 1280 thermal elements with each element shaped like a tiny dot. The dot line is 4 inches (101.6 mm) in length resulting in a dot density of 305 DPI. As the paper is advanced through the printer by the paper feed mechanism, the thermal head continuously prints the image as a series of dot lines at a resolution of 305 dots per inch, horizontally and vertically.

Precision feeding and back feeding of the label stock is accomplished through the use of specialized stepping motors and photo-sensors. The label gap sensor or the black mark sensor tells the printer electronics when the label stock is properly positioned under the head for accurate printing.

6.2 Installing the Printer Drivers

NOTE:

"X" will be replaced with your CD drive's letter. (e.g. D, E, etc.)

NOTE:

1. When downloading the printer driver from TEC Web Site, confirm the version and use the latest printer driver. The supplied CD-ROM contains 'Bdrv_V6_5_Build77.exe'.
2. Driver file name, capacity, and date of the driver may be changed without prior notification. For the latest information about the driver, please contact your authorised TOSHIBA TEC representative.

Before you can use the printer, it is necessary to install the printer driver to your PC. Installation is accomplished by first installing the set of printer driver files from the supplied CD-ROM.

Run the following SETUP.EXE.

"X":\DRIVE\SETUP.EXE

The latest printer driver can be obtained from the TOSHIBA TEC Barcode Web Site. Access the TOSHIBA TEC Barcode World Wide Web Site at the following URL:

<http://barcode.toshibatec.co.jp/Eng/download.html>

Double click on the downloaded file ("Bdrv_Vx_x_Buildxx.exe"), and then run the following SETUP.EXE. ("C:\TEC\MONO\CD" is the default install directory.)

"C:\TEC\MONO\CD"\SETUP.EXE

6.2.1 System Requirements

NOTE:

Windows 3.1® is not supported. Windows 3.1®, Windows 95®, Windows 98®, Windows NT® and Windows 2000 ® are registered trademarks of Microsoft Corporation. Pentium® is a registered trademark of Intel Corporation

1. System

- IBM Compatible PC running Windows 95® or Windows 98® or Windows NT® Version 4.0 Workstation, Windows NT® Version 4.0 Server, Windows 2000® Professional, or Windows 2000® Server.
- Pentium® processor, 133MHz or greater recommended.
- Installed memory of 16MB minimum (32MB recommended).
- Available Hard Disk space of 10MB or more.

2. Interface

- The RS-232C interface
- Centronics interface

6.2.2 Driver Installation

NOTE:

- How to install the printer driver from the supplied CD-ROM is described below.
- When the printer driver is downloaded from TOSHIBA TEC Web Site, type in "C:\TEC\MONO\CD\SETUP.EXE". C:\TEC\MONO\CD is the default install directory generated when the printer driver file (Bdrv_Vx_x_Buildxx.exe) is run.

- Insert the supplied CD-ROM into the CD drive of your PC.
- Click on the **START** button, then select and click on the **Run...**
- Type in "D:\DRIVER\SETUP.EXE" and click on the **OK** button. ("D" may be replaced with your CD drive's letter.)



- The screen will change as shown below.

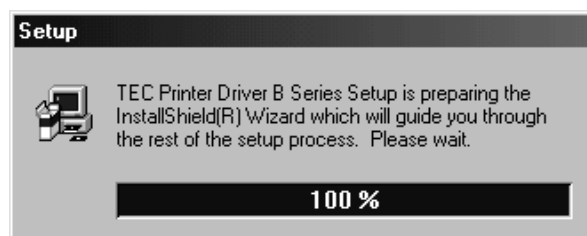

- After the Install Shield temporary files have been loaded, the display will change to the Welcome screen as shown below.



6.2.2 Driver Installation (Cont.)

6. Click on the **Next** button to continue the installation. The screen will change to the Software License Agreement screen.

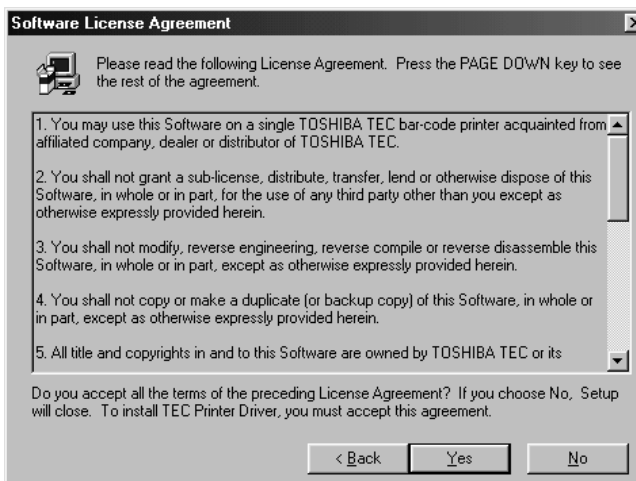

NOTE:

*If you click on the **No** button in the License Agreement screen, the program will not be installed.*

7. Carefully read the Software License Agreement. To accept the conditions of the agreement, click on the **Yes** button. If you do not accept the conditions click on the **No** button.
8. Upon clicking on the Yes button, the screen will change to list the available TEC driver sets. For this printer, select “TEC B-492” and click on the **Next** button.

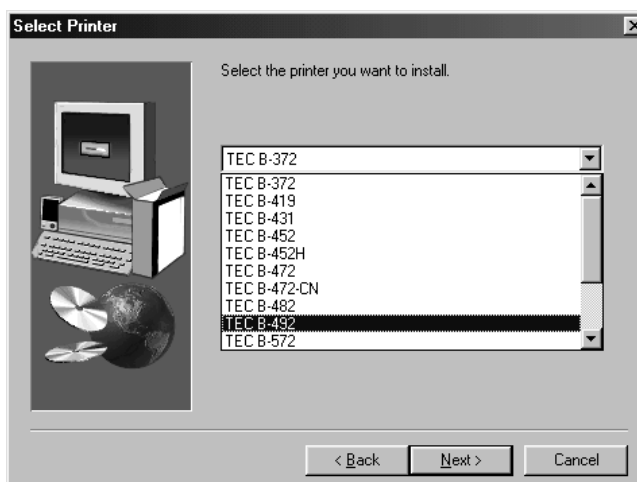

9. The screen will change to the following. When the printer is directly connected to this PC, select “Local Printer”, otherwise, select “Network Printer”. Then click on the **Next** button.

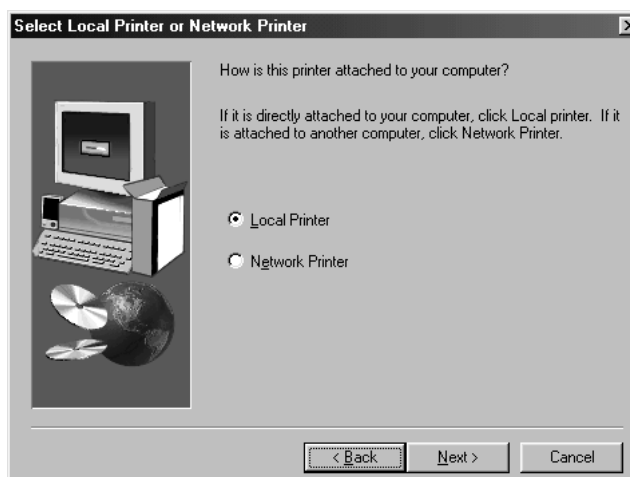

6.2.2 Driver Installation (Cont.)

If you selected the Local Printer in the previous step, go to Step **10**.
If you selected the Network Printer in the previous step, go to Step **11**.

- 10.** When you selected the Local Printer in Step **9**, select the PC port to which this printer is connected.

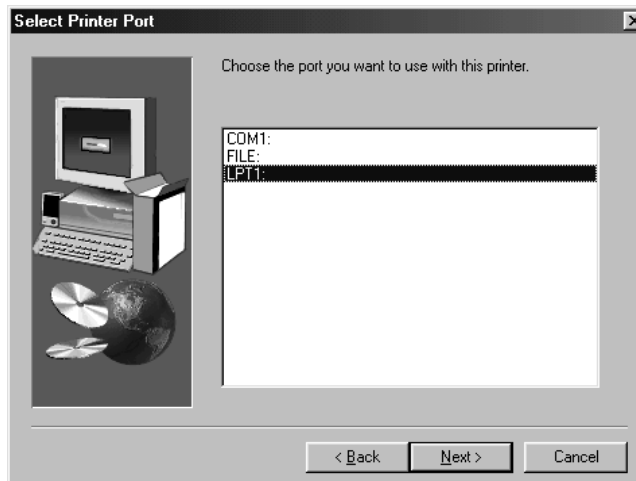

NOTE:

Be sure to select the same printer that you are going to install.

- 11.** When you selected the Network Printer in Step **9**, enter a network path, and click on the **Next** button. If the network path is unknown, click on the **Browse...** button and select the same printer that you chose in Step **8**.

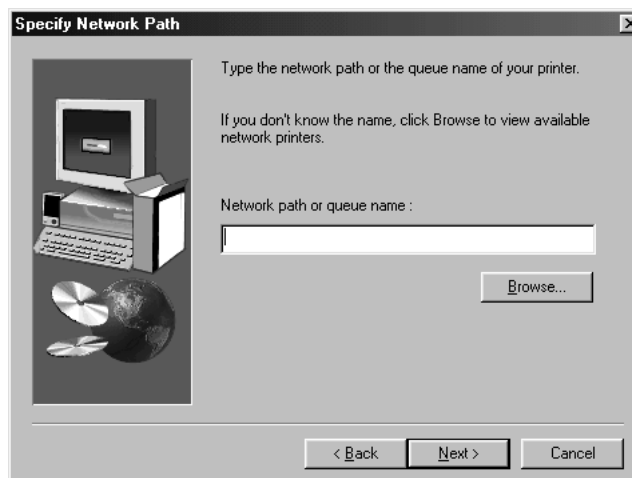

NOTE:

*If you specify the same name as already installed printer, that printer will be overwritten.
When you desire to install the same printer for many times, change the printer name each time.*

- 12.** The screen will show the selected printer name. Change the printer name, if necessary.

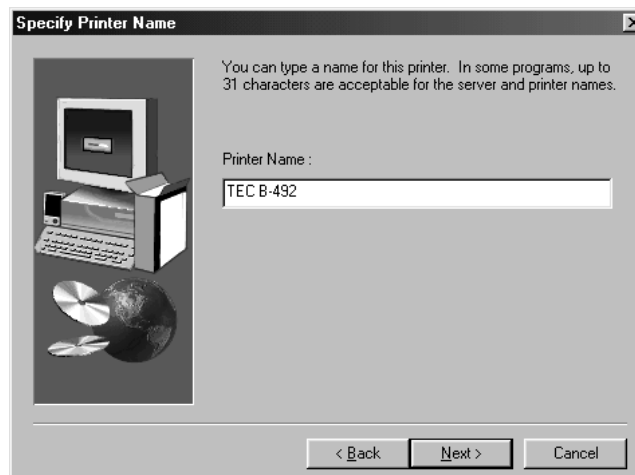

6.2.2. Driver Installation (Cont.)

13. Upon clicking on the **Next** button on the previous screen, the printer driver files copy will start.

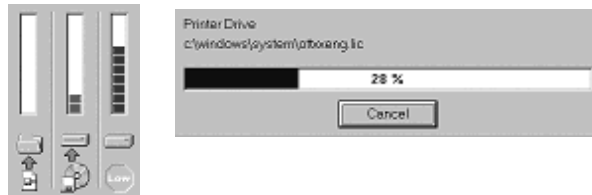

14. After all of the files have been transferred the display will change to the Setup Complete screen. Select “Yes, I want to restart my computer now.”, then click on the **Finish** button.



15. After the TEC Printer Driver has been successfully loaded, the Printers screen should appear as shown below, showing the TEC B-492 as being successfully installed.



6.2.3 Uninstalling the TEC B-492 Printer Driver

If it becomes necessary to remove the TEC-B-492 printer driver from your host computer, then it can be removed as follows.

1. Access the Windows Control Panel and click on the **Add/Remove Programs** icon.
2. Select "TEC B-492 Printer" and click on the **Add/Remove** button.

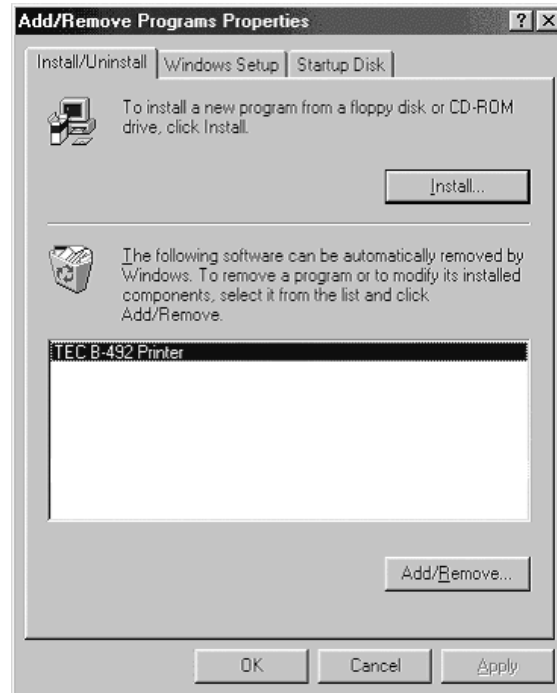

3. When the following screen appears, click on the **Yes** button.

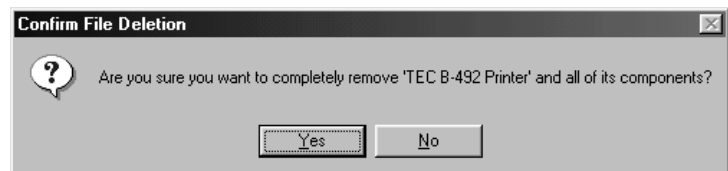

NOTES:

If the registration information is deleted, the registered labels will not be able to be used when the printer driver is re-installed.

4. When the Registration information deletion screen appears, click on the **Yes** button if you desire to delete the paper information. If you do not desire to delete the information, click on **No** button. If this message does not appear, go to the next step.

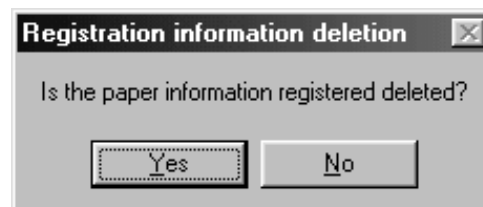

6.2.3 Uninstalling the TEC B-492 Printer Driver (Cont.)

5. When the following screen appears, click on the **Yes To All** button. If this screen does not appear, the screen of Step 7 will appear instead.

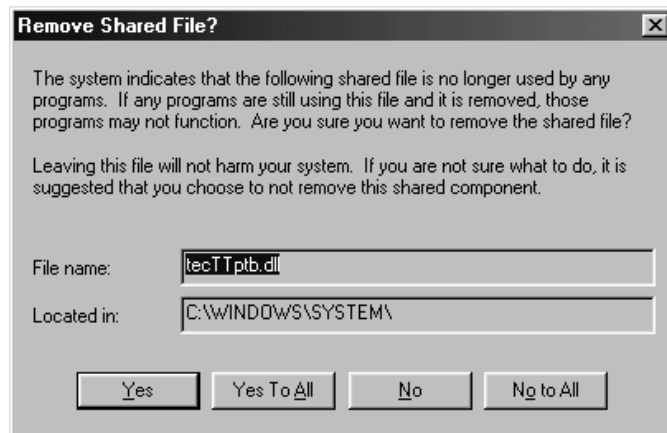

6. Upon clicking on the **Yes To All** button, the following screen appears to confirm the deletion of shared file. Click on the **Yes** button.

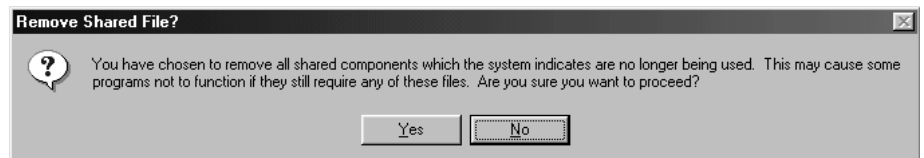

7. Printer driver deletion starts. When the deletion is completed, click on the **OK** button.



NOTE:

Deleting the shared files does not affect other programs.

NOTE:

Please note that it may take time to delete the printer driver.

APPENDIX 1 SPECIFICATIONS

Appendix 1 describes the printer specifications and supplies for use on the B-492L/R printer.

A1.1 Printer

The following are the printer specifications.

Item	Model	B-492L/R-TH10-QQ	B-492L/R-TH10-QP
Supply voltage		AC120V, 60 Hz	AC220 to 240V, 50Hz
Power consumption			
During a print job		1.3 A, 123 W maximum	0.7A, 126W maximum
During standby		0.17 A, 22 W maximum	0.06A, 24W maximum
Operating temperature range		5°C to 40°C (40°F to 104°F)	
Relative humidity		25% to 85% RH (no condensation)	
Resolution		12 dots/mm (305 dpi)	
Printing method		Thermal transfer or Thermal direct	
Printing speed			
Thermal transfer printing		127 mm/sec. (5"/sec.), 203.2 mm/sec. (8"/sec.), 254 mm/sec. (10"/sec.)	
Thermal direct printing		101.6 mm/sec. (4"/sec.), 127 mm/sec. (5"/sec.), 203.2 mm/sec. (8"/sec.)	
Available media width (including backing paper)		20 mm to 112 mm (0.8" to 4.4")	
Effective print width (max.)		104.0±0.2 mm (4.1")	
Product type		B-492L: for a left flow line, B-492R: for a right flow line	
LCD Message display		16 characters/line	
Dimension (W × D × H)		329 mm × 245 mm × 300 mm (13.0" × 9.6" × 11.8")	
Weight		Depth of the PCB block: 125 mm (4.9")	
Available bar code types		13 kg (28.7 lb) (Excluding Media and ribbon)	
Available two-dimensional code		JAN8, JAN13, EAN8, EAN8+2 digits, EAN8+5 digits, EAN13, EAN13+2 digits, EAN13+5 digits, UPC-E, UPC-E+2 digits, UPC-E+5 digits, UPC-A, UPC-A+2 digits, UPC-A+5 digits, MSI, ITF, NW-7, CODE39, CODE93, CODE128, EAN128, Industrial 2 to 5, Customer Bar Code, POSTNET, KIX CODE, RM4SCC (ROYAL MAIL 4STATE CUSTOMER CODE)	
Available bar font		Data Matrix, PDF417, QR code, Maxi Code, Micro PDF417	
Rotations		Times Roman (6 sizes), Helvetica (6 sizes), Presentation (1 size), Letter Gothic (1 size), Prestige Elite (2 sizes), Courier (2 sizes), OCR (2 types), Outline font (4 types), Price font (3 types)	
Standard interface		0°, 90°, 180°, 270°	
Optional interface		Serial interface (RS-232C) Parallel interface (Centronics) Keyboard interface Expansion I/O interface	
Optional interface		PCMCIA interface (B-7708-PC-QM)	

NOTES:

- *Data Matrix™* is a trademark of International Data Matrix Inc., U.S.
- *PDF417™* is a trademark of Symbol Technologies Inc., US.
- *QR Code* is a trademark of DENSO CORPORATION.
- *Maxi Code* is a trademark of United Parcel Service of America, Inc., U.S.

A1.2 Options

Option Name	Type	Description	Source
Keyboard module	KB-80-QM	This module is an external intelligent keyboard unit, including a 16 digit by 2 line LCD and 28 key switches.	See NOTE.
PCMCIA interface board	B-7708-PC-QM	This board enables the use of the following PCMCIA cards: LAN card: 3 COM EtherLink® III (recommended) ATA card: Conforming to PC card ATA standard Flash memory card: 4MB card (See page 2-13.)	See NOTE.

NOTE:

Available from your nearest TOSHIBA TEC representative or TOSHIBA TEC Head Quarters.

A1.3 Media

Please make sure that the media to be used is approved by TOSHIBA TEC. The warranties do not apply to problems caused by using media that is not approved by TOSHIBA TEC.

For information regarding TOSHIBA TEC-approved media, please contact a TOSHIBA TEC authorized service representative.

A1.3.1 Media Type

This thermal transfer/direct thermal printer is specifically designed for label media. The table below shows the size and shape of the media available for this printer.

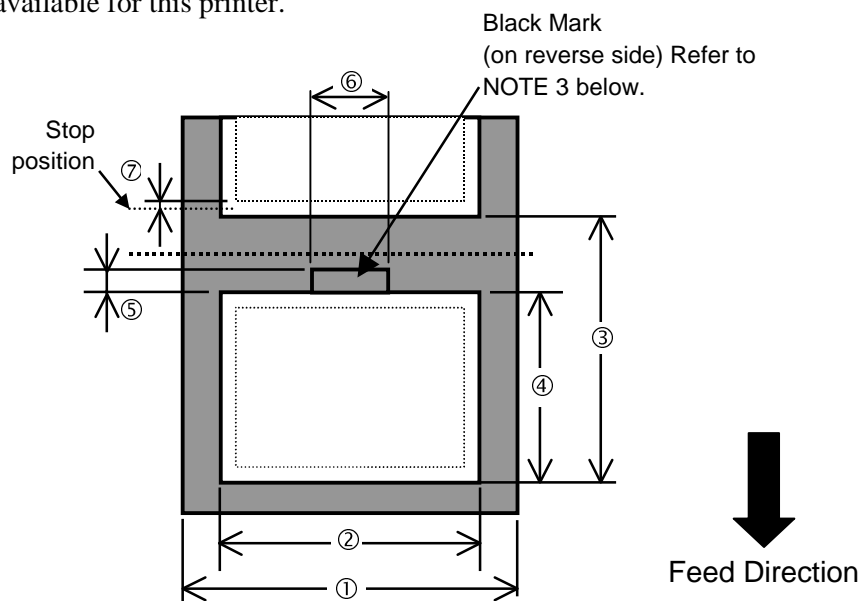

A1.3.1 Media Type (Cont.)

Unit: mm+(inch)

Item	Batch mode	Strip mode
① Width including backing paper	20 to 112 (0.8 to 4.4)	
② Label width	Min. 17 (0.7)	
③ Label pitch	12 to 999 (0.5 to 39.3)	12 to 999 (0.5 to 39.3) 10 ips: 25.4 to 999 mm (1 to 39.3)
④ Label length	Min. 10 (0.4)	Min. 10 (0.4) 10 ips: Min. 23.4 (0.9)
⑤ Gap length (or black mark length)	2 to 20 (0.08 to 0.8)	
⑥ Black mark width	Min. 12 (0.5)	
Thickness	0.13 to 0.18 (0.005 to 0.007)	
Max. outer roll diameter	φ200 (Reference value, See NOTE 6.)	
Roll direction	Inside rolled paper is recommended.	
Inner core diameter	76.2±0.3 (3±0.01) (Reference value)	

NOTES:

1. To ensure print quality and print head life use only TOSHIBA TEC approved media.
2. For the backing paper Glassine paper 7K white or equivalent should be used. Also, the light transmission rate of the backing paper should be 22% or above.
3. When perforating the media, it should be done from the print side to the reverse side.
4. Ink used for pre-printing the media should not contain hard substances such as carbonic calcium (CaCO₃) and Kaolin (Al₂O₃, 2SiO₂, 2H₂O).
5. The reflectance of the black mark should be 10% or less when the wavelength is 950nm.
6. As this printer does not have a label holder, this figure is a guide for the system integrator using this printer. When the outer roll diameter of the labels being used is 200 mm or less, a hanging type supply holder similar to the type used in TEC desktop thermal printer's will work correctly. When the outer roll diameter exceeds 200 mm, the label holder should have mechanisms, such as bearings, a damper, etc. to reduce the tension on the label. In any case, prior to actual operation, please be sure to test all practical conditions including the labels, system, etc. and confirm there is no problem.

A1.3.2 Detection Area of the Transmissive Sensor

The transmissive sensor is movable from the center to the left edge of the media.

The transmissive sensor detects gaps between labels, as illustrated below.

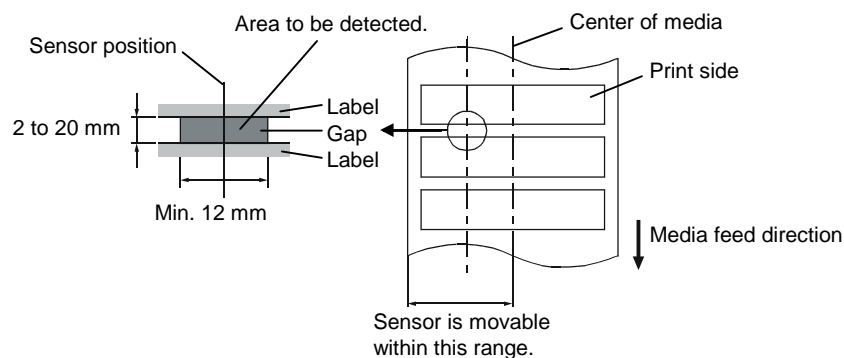

A1.3.3 Detection Area of the Reflective Sensor

The reflective sensor is movable from the center to the left edge of media.
 The reflection factor of the black mark must be 10% or lower with a waveform length of 950 nm.
 The reflective sensor should be aligned with the center of the black mark.

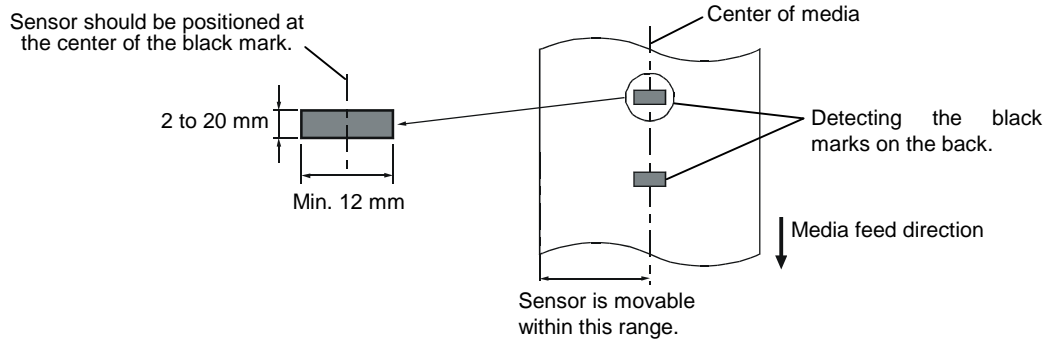

A1.3.4 Effective Print Area

The figure below illustrates the relation between the head effective print width and media width.

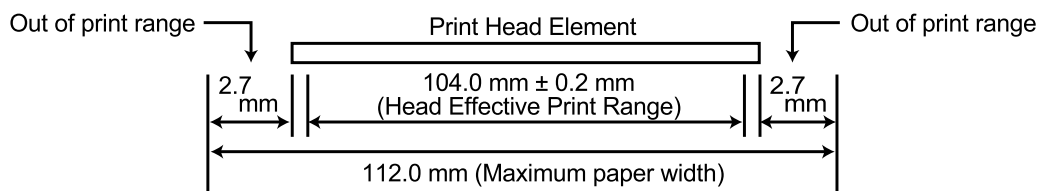

The figure below shows the effective print area on the media.

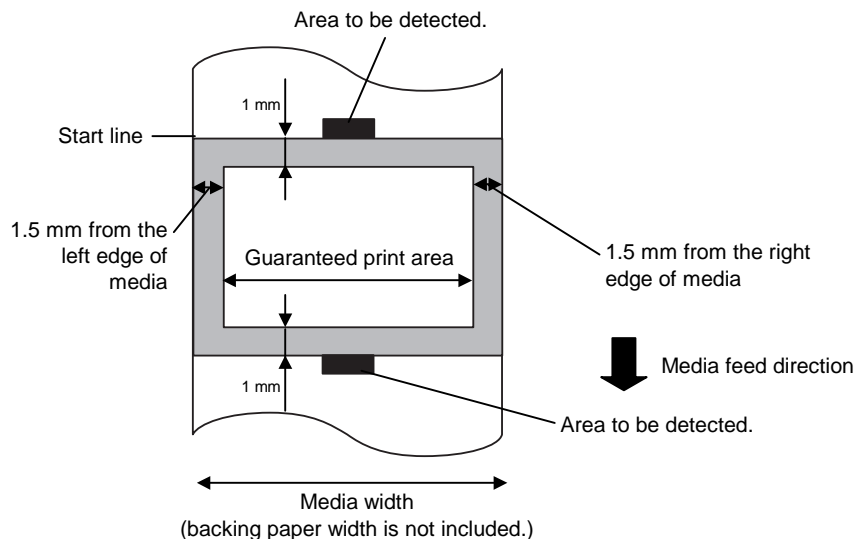

NOTES:

1. Avoid printing in the area 1.5-mm wide from the media edges (shaded area in the above figure).
2. The center of media is positioned at the center of the print heads.
3. Print quality is not guaranteed within 3 mm from the print head stop position (including 1-mm slowup).
4. Average print (black) rate should be 15% or less. For bar code print area, the print rate should be 30% or less.
5. Line weight should be 3 to 12 dots.

A1.4 Ribbon

Please make sure that the ribbon being used is approved by TOSHIBA TEC. The warranties do not apply to any problem caused by using non-approved ribbons.

For information regarding TOSHIBA TEC approved ribbon, please contact a sales representative.

Type	Spool type
Width	41 – 112 mm (1.6” to 4.4”) 41, 68, 84 and 112 mm (1.6”, 2.7”, 3.3”, 4.4”) are recommended.
Length	600 +10, -0 m (Max.)
Outside Diameter	φ90 mm (φ3.5”) (Max.)

NOTES:

1. To ensure print quality and print head life use only TOSHIBA TEC specified ribbons.
2. To avoid ribbon wrinkles use a ribbon which is the correct width for each media width used.
It is possible to use narrower ribbons than media width, however, the effective print width also narrows

Ribbon width	41 mm	68 mm	84 mm	112 mm
Proper media width	20 to 36 mm	36 to 63mm	63 to 79 mm	79 to 112mm

APPENDIX 2 MESSAGES AND LEDS

Appendix 2 describes the LCD messages displayed on the operation panel.

Symbols in the message

- 1: ○: The LED is illuminated. ⊙: The LED is flashing. ●: The LED is unlit.
- 2: ****: the remaining number of labels to be printed. Up to 9999 (pieces)
- 3: %%% %%%: ATA Card's remaining memory 0 to 9999999 (in K bytes)
- 4: ###: Flash memory card remaining memory for PC save area: 0 to 895 (in K bytes)
- 5: &&&&: Remaining flash memory capacity for storing writable characters 0 to 3147 (in K bytes)

No.	LCD Message	LED Indication			Printer Status	Restoration by RESTART key Yes/No	Acceptance of Status Request Reset Command Yes/No
		POWER	ONLINE	ERROR			
1	ON LINE	○	○	●	In online mode	----	Yes
	ON LINE	○	⊙	●	In online mode (The printer is receiving a communication)	----	Yes
2	HEAD OPEN	○	●	●	The print head block is opened in online mode.	----	Yes
3	PAUSE ****	○	●	●	The printer is paused.	Yes	Yes
4	COMMS ERROR	○	●	○	A parity, overrun, or framing error has occurred during communication through the RS-232C port.	Yes	Yes
5	PAPER JAM ****	○	●	○	The media has jammed during feed.	Yes	Yes
6	NO PAPER ****	○	●	○	The media has run out, or the media is not loaded correctly.	Yes	Yes
7	RIBBON ERROR****	○	●	○	The ribbon has run out, or has snapped. A problem has occurred with the sensor that determines the torque for the ribbon motor.	Yes	Yes
8	HEAD OPEN ****	○	●	○	Feeding or printing was attempted with the print head block open.	Yes	Yes
9	COVER OPEN ****	○	●	○	Feeding or printing was attempted with the top cover open.	Yes	Yes
10	PINCH OPEN ****	○	●	○	Feeding or printing was attempted with the pinch roller raised.	Yes	Yes
11	PEEL OPEN ****	○	●	○	Feeding or printing was attempted with the strip pinch roller unit open.	Yes	Yes
12	GUIDE OPEN ****	○	●	○	Feeding or printing was attempted with the media guide plate removed.	Yes	Yes
13	EXCESS HEAD TEMP	○	●	○	The print head has overheated.	No	Yes
14	SAVING%%%%%%%% or SAVING ###&&&&	○	○	●	In writable character or PC command save mode	----	Yes
15	FLASH WRITE ERR.	○	●	○	An error has occurred while formatting the flash memory or ATA card.	No	Yes
16	FORMAT ERROR	○	●	○	An erase error has occurred in formatting the flash memory or ATA card.	No	Yes
17	FLASH CRD FULL	○	●	○	Data cannot be stored because the flash memory or ATA card is full.	No	Yes
18	HEAD ERROR	○	●	○	There is a problem with the print head.	Yes	Yes
19	Display of error message (See Notes.)	○	●	○	The data analyzer has found an error in the displayed command.	Yes	Yes

NOTES:

- If a corrupt command is received, the first 16 bytes of the command, starting from the command code, will be displayed. (However, [LF] and [NUL] will not be displayed.)

Example 1

[ESC] PC001;0A00,0300,2,2,A,00,B [LF] [NUL]

└─── Corrupt data

The following message appears.

PC001;0A00,0300

Example 2

[ESC] XR; 0200, 0300, 0450, 1200, 1, [LF] [NUL]

└─── Command error

The following message appears.

XR;0200,0300,045

Example 3

[ESC] T20E 30 [LF] [NUL]

└─── Corrupt data

The following message appears.

T20E30

- The character “?” (3FH) is displayed for character codes outside the ranges 20H to 7FH and A0H to DFH.

APPENDIX 3 INTERFACE

■ Interface Cables

To prevent radiation and reception of electrical noise, the interface cables must meet the following requirements:

- Fully shielded and fitted with metal or metallized connector housings.
- Keep as short as possible.
- Should not be bundled tightly with power cords.
- Should not be tied to power line conduits.

■ RS-232C Cable description

The serial data cable used to connect the printer to a host computer should be one of the following two types:

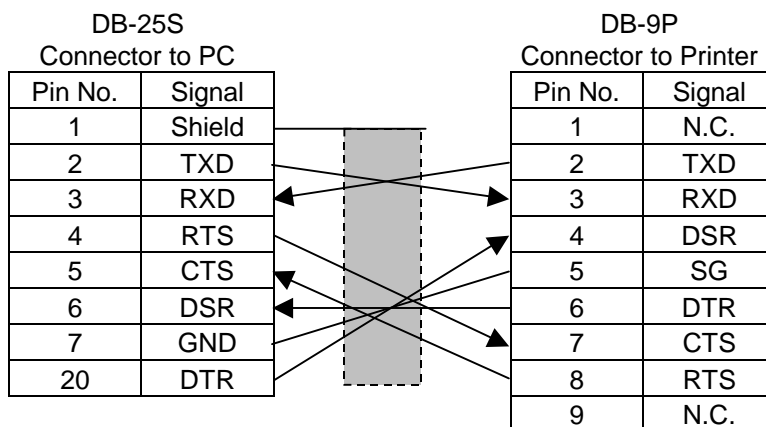
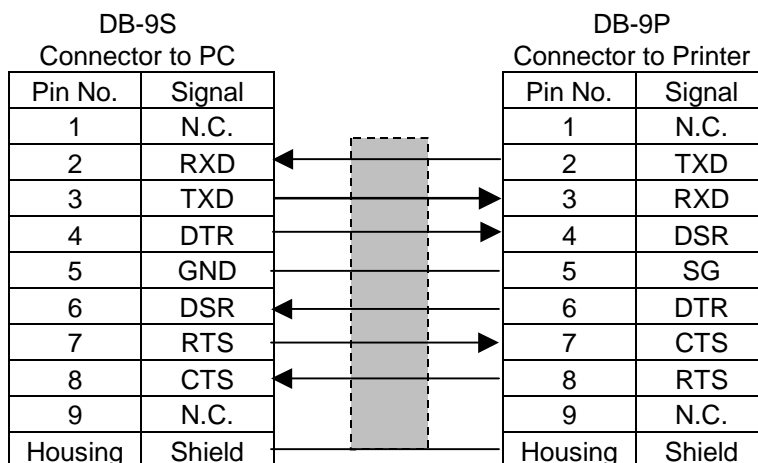

NOTE:

Use an RS-232C cable with inch type securing screws on the connector.

APPENDIX 4 SYSTEM MODE

Appendix 4 describes usage of the keys on the Operation Panel in System Mode.

For end users, System Mode should be used for the following five purposes:

- To reset the printer. (Reset mode)
- To check and print the system status, the Maintenance Counter, and to check the Print Head Elements.
- To make fine adjustment to the media handling.
- To perform a test print for checking print quality.
- To print the raw data being received by the printer (Dump mode).

IMPORTANT!

If System Mode is needed for any other purposes, please contact a TOSHIBA TEC authorized service representative before performing any operation in System Mode.

A4.1 Operation Panel

The figure below shows the Operation Panel and key functions.

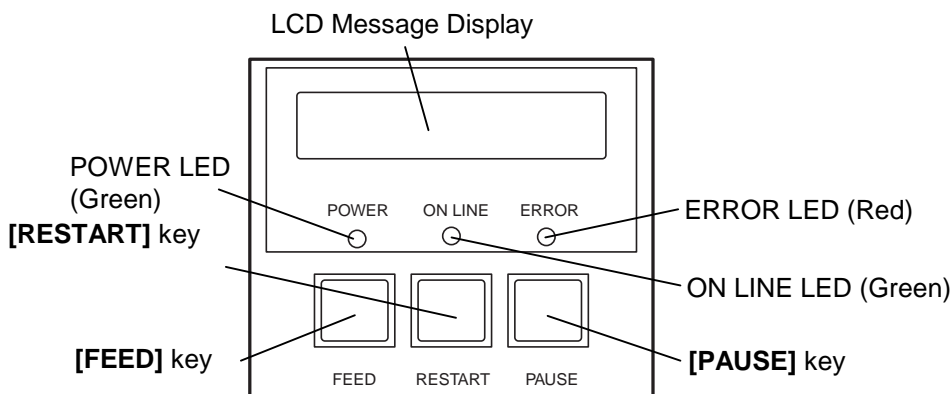

The LCD Message Display shows messages to indicate the printer's current status. Up to 16 characters can be displayed on this line.

There are three LEDs on the Operation Panel.

LED	Illuminates when...
POWER	The printer is turned on.
ON LINE	The printer is ready to print.
ERROR	Any error occurs on the printer.

In System Mode, the **[FEED]**, **[RESTART]** and **[PAUSE]** keys function as described below.

FEED	Used to navigate the parameter mode or to fine adjust the parameters in the negative direction (- Down).
RESTART	Used to release the printer from Pause condition, to navigate the parameter mode, or to fine adjust the parameters in the positive direction (+ Up). By pressing and holding the [RESTART] key in Pause condition for more than 3 sec., the printer enters the system mode.
PAUSE	Used to stop printing operation temporarily, to select the parameter mode, or used as an enter key. By pressing and holding the [PAUSE] key in Pause condition for more than 3 sec., the printer enters the threshold setting mode.

NOTE:

*Use the **[RESTART]** key to resume printing after a pause condition, or after clearing an error.*

A4.2 Overview

IMPORTANT!

The following menus are for Service Personnel only:

- <2>PARAMETER SET
- <5>SENSOR ADJ.
- <6>RAM CLEAR
- <7>IP ADDRESS

Please do not change the settings for these items, as doing so may cause the printer to malfunction. If you should accidentally enter these System Modes, to exit just turn the power off. If you should change any of the settings by accident and the printer malfunctions, please contact your nearest TOSHIBA TEC service representative.

NOTE:

1. To navigate the System Mode menus the [RESTART] and [FEED] key can be used.
2. Pressing the [PAUSE] key will enter the sub menus of each System Mode menu. Flowcharts of each sub menu are provided on the following pages.

The System Mode consists of nine main menu items: Reset, Self-Diagnostic Test, Parameter Setting, Printer Parameter Fine Adjustment, Test Print, Sensor Adjustment, RAM Clear, IP Address Setting, and Dump mode.

Press the [PAUSE] key so that the printer enters the Pause condition. Then, press and hold the [RESTART] key until “<0>RESET” appears on the display.

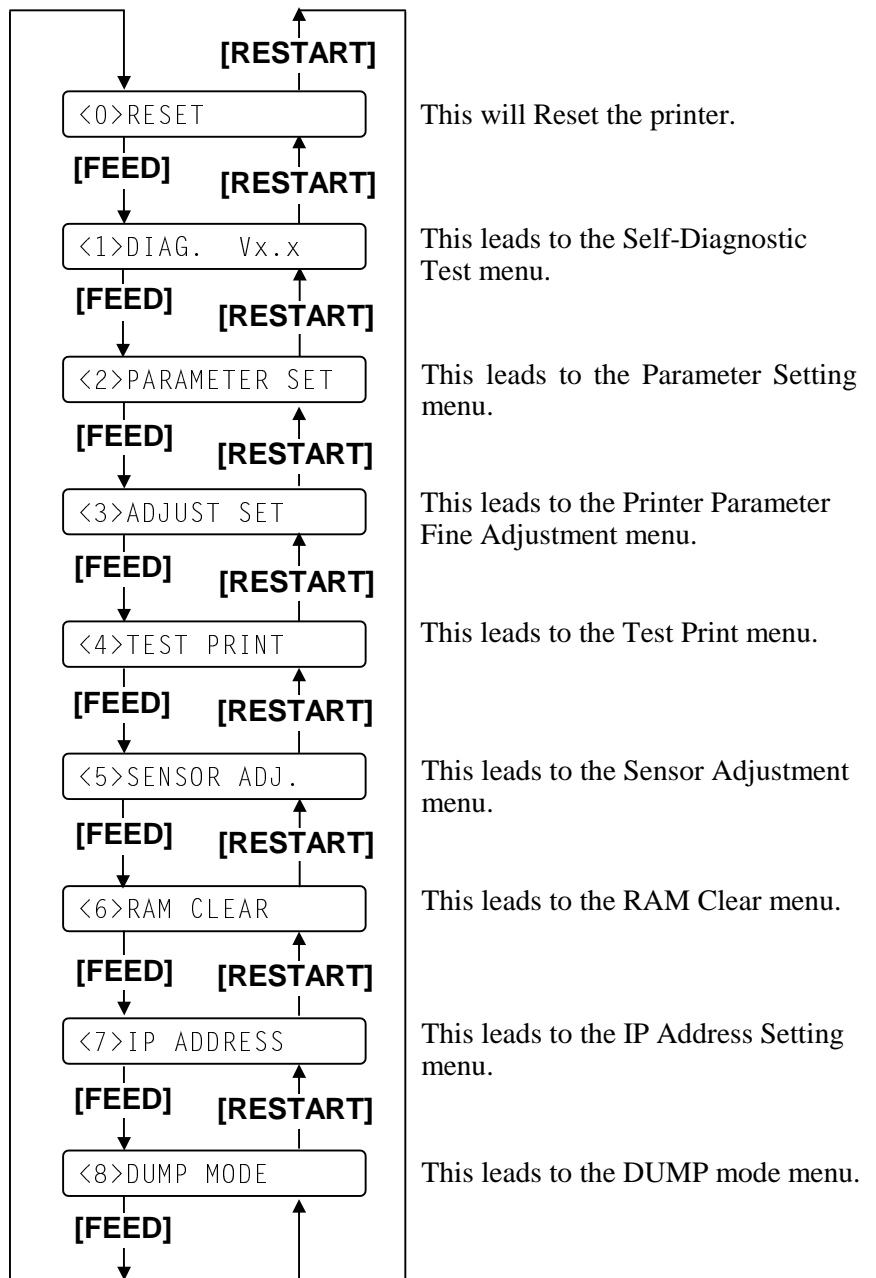

A4.3 Reset Mode

The Reset operation clears all the print data that has been sent to the printer from the computer, and returns the printer to an idle condition.

NOTE:
 If the **[RESTART]** key is held for less than 3 seconds when the printer is in an error or pause state, the printer will restart printing. However, when a communication error or command error occurs, the printer will return to an idle condition.

1. The printer is on, standing by, or printing.

ON LINE

2. To stop printing, or clear the data sent from the computer, press the **[PAUSE]** key. The printer stops printing.

PAUSE 52

3. Press and hold the **[RSTART]** key for 3 seconds or longer.

<0>RESET

4. Press **[PAUSE]** key. All data that has been received sent from the computer will be cleared, and the printer returns to an idle condition.

ON LINE

A4.4 Self-Diagnostic Test

The **Self-Diagnostic Test** contains the following sub menus:

Outline of Self-Diagnostic Test
 In the Self-Diagnostic Test mode, the printer checks and prints out the printer system information such as the sensor or interface, and the Maintenance Counter. It also performs the print head broken element check.

NOTE:
 Use the **[FEED]** or **[RESTART]** key to select a desired option.

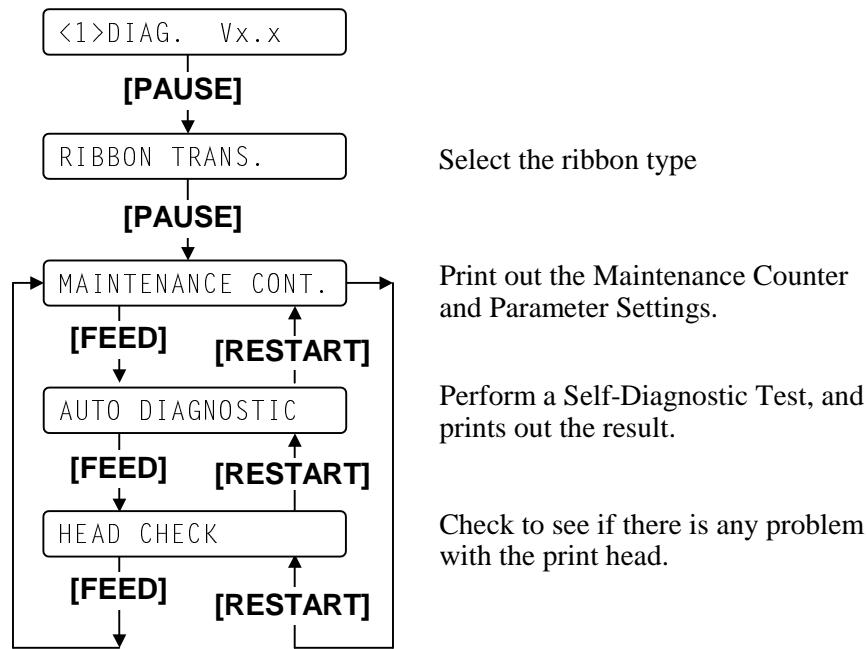

A4.4 Self-Diagnostic Test (Cont.)

While in a Pause condition press and hold the **[RESTART]** key until “<0>RESET” appears in the display.

<0>RESET

Then, press the **[FEED]** key, and “<1>DIAG. Vx.x” message appears.

<1>DIAG. Vx.x

Ribbon type selection

Press the **[PAUSE]** key. The ribbon type can be selected: “NO RIBBON” (Direct Thermal Paper), “TRANS.” (Transmissive ribbon), or “NO TRANS.” (Non transmissive ribbon). After selecting the ribbon type, press the **[PAUSE]** key to confirm and go to Maintenance counter and Parameter settings print out.

NOTE:
When using a ribbon, be sure to select “TRANS” or “NO TRANS.”. When using direct thermal media, be sure to select “NO RIBBON”.

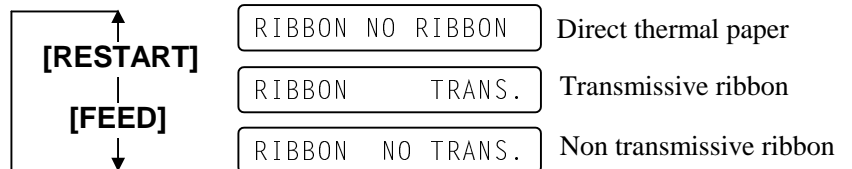

Maintenance counter/parameter settings print out

The printer will print out the Maintenance Counter and Parameter Settings. Press the **[PAUSE]** key to start.

MAINTENANCE CONT

The printer starts printing out the Maintenance Counter & Parameter Settings.

CHECKING & PRINT

After printing is completed, the display returns to “<1>DIAG. Vx.x”.

NOTE:
See Section A4.8.2 for a Maintenance Counter and Parameter Settings print sample and a detailed description for each item.

Self-Diagnostic Test and the result print out

After the Maintenance Counter and Parameter Settings print out has been completed, the display returns to “<1>DIAG. Vx.x”. Press the **[PAUSE]** key twice then **[FEED]** key once.

The Self-Diagnostic Test is ready. Press the **[PAUSE]** key to start.

AUTO DIAGNOSTIC

The printer starts the Self-Diagnostic Test, and prints out the result.

CHECKING & PRINT

After printing is completed, the display returns to “<1>DIAG. Vx.x”.

NOTES:

1. If an error occurs, an error message appears, and the printer stops printing. After clearing the error, press the **[PAUSE]** key to return to “<1>DIAG.”. The printer does not resume printing automatically.
2. See Section A4.8.1 for Self-Diagnostic Test Print sample and a detailed description of each item.

A4.4 Self-Diagnostic Test (Cont.)

NOTES:

1. Make sure that the Top Cover is closed before starting the print head check.
2. If "HEAD ERROR" appears, then some print head elements may be damaged. To sustain high quality printing, please contact your nearest TOSHIBA TEC service representative for the print head replacement.

Print head element check

After the Self-Diagnostic Test result has been printed, the display returns to "<1>DIAG. Vx.x". Press the **[PAUSE]** key twice then **[FEED]** key twice.

The printer is ready to check the print head to see if there are any problems with the print head. Press the **[PAUSE]** key to start.

HEAD CHECK

The printer starts checking the print head.

CHECKING

If there is no problem with the print head, the print head check is complete. Press the **[PAUSE]** key to return to "<1>DIAG. Vx.x".

NORMAL END

If there is a problem with the print head, the following message is displayed.

HEAD ERROR

Press the **[PAUSE]** key to return to "<1>DIAG. Vx.x".

A4.5 Printer Parameter Fine Adjustment

The **Printer Parameter Fine Adjustment** menu contains the following.

Outline of Printer Parameter Fine Adjustment

In the Printer Parameter Fine Adjustment mode, Fine adjustments can be made for each parameter, like Print tone, Print start position, Threshold, etc. which can also be set by PC commands. This is useful when using several types of media in rotation or when the print start position or strip position requires some fine adjustment.

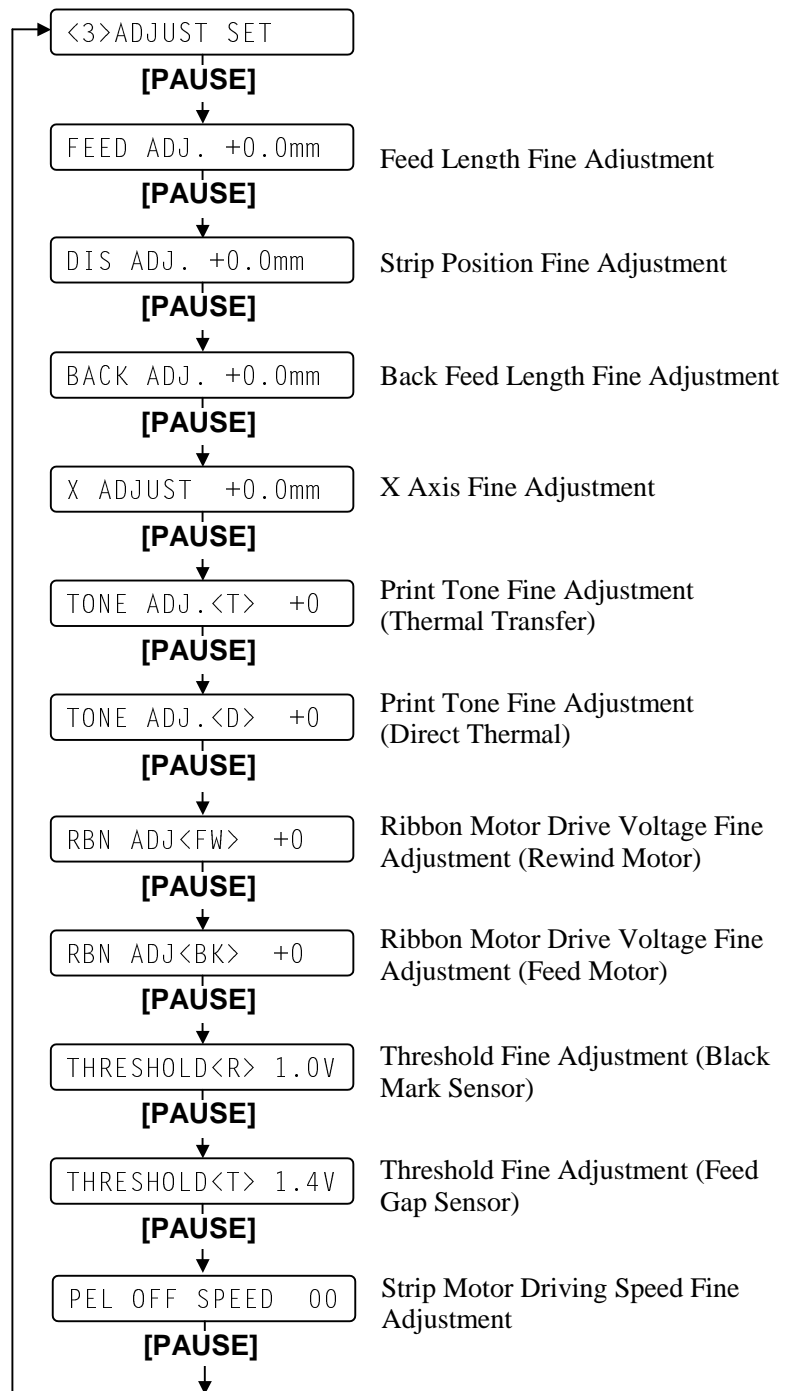

A4.5 Printer Parameter Fine Adjustment (Cont.)

NOTES:

1. If the **[FEED]** and **[RESTART]** keys are pressed at the same time in the parameter setting, the message returns to “<3>ADJUST SET”.
2. If holding the **[FEED]** or **[RESTART]** key for 0.5 seconds or longer in the Printer Parameter Fine Adjustment, the key will auto repeat.
3. A changed parameter becomes enabled by pressing the **[PAUSE]** key
4. Use the **[FEED]** or the **[RESTART]** key to change to a desired value or option.

While in a Pause condition press and hold the **[RESTART]** key until “<0>RESET” appears in the display.

<0>RESET

Then, press the **[FEED]** key three times, and “<3>ADJUST SET” is displayed.

<3>ADJUST SET

Feed Length Fine Adjustment

With this parameter you can fine adjust position of the image on the media. With “<3>ADJUST SET” displayed, press the **[PAUSE]** key.

FEED ADJ. +0.0mm

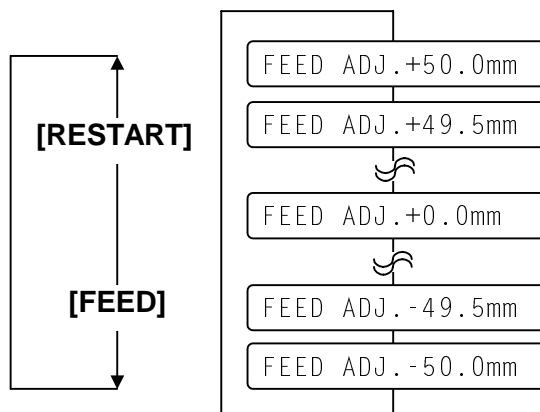

Feed Length Fine Adjustment (Example)

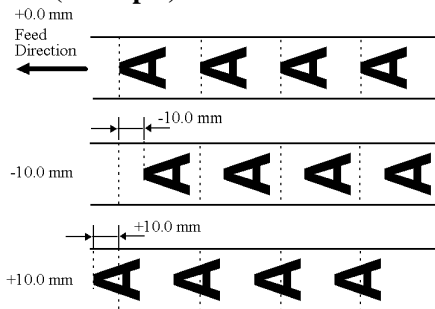

[FEED] key: Pressing the **[FEED]** key once causes a -0.5mm change, down to -50.0 mm.

[RESTART] key: Pressing the **[RESTART]** key once causes a +0.5mm change, up to +50.0 mm.

After completing the fine adjustment, press the **[PAUSE]** key.

NOTE:

The fine adjustment value equals the sum of the fine adjustment values set by the PC command and this parameter. The maximum feed length fine adjustment value is ±50.0mm. When the addition of values reaches the maximum, the value remains unchanged even if subsequent fine adjustments are made.

A4.5 Printer Parameter Fine Adjustment (Cont.)

Strip Position Fine Adjustment

With this parameter you can fine adjust the dispense position. With “<3>ADJUST SET” displayed, press the [PAUSE] key twice.

Strip Position Fine Adjustment (Example)

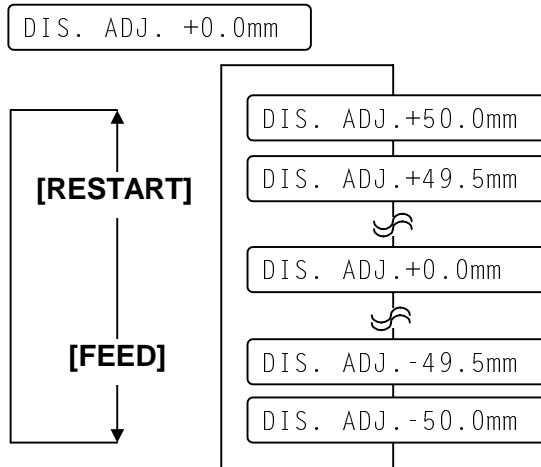
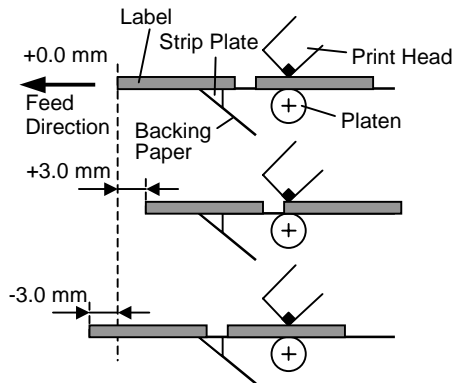

NOTES:

1. In strip issue, the media feed should be stopped where a 1 mm length of label remains on the strip plate. If, however, the feed stop position is improper due to too long gap length, etc., a fine adjustment should be performed.
2. The fine adjustment value equals the sum of the fine adjustment values set by the PC command and this parameter.
The maximum strip position fine adjustment value is ±50.0mm. When the addition of the values reaches the maximum, the value remains unchanged even if subsequent fine adjustments are made.

- [FEED]** key: Pressing the [FEED] key once causes a -0.5mm change, down to -50.0 mm.
- [RESTART]** key: Pressing the [RESTART] key once causes a +0.5mm change, up to +50.0 mm.

After completing the fine adjustment, press the [PAUSE] key.

A4.5 Printer Parameter Fine Adjustment (Cont.)

Back Feed Length Fine Adjustment

With this parameter you can fine adjust the Back Feed Length. With “<3>ADJUST SET” displayed, press the **[PAUSE]** key 3 times.

Back Feed Length Fine Adjustment (Example)

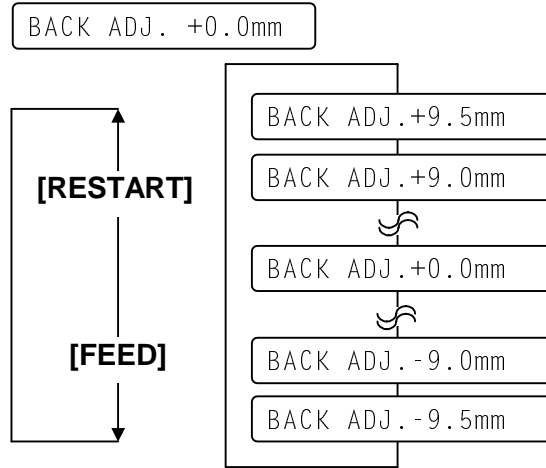
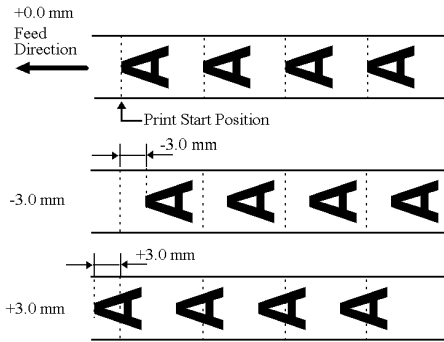

NOTE:
 The fine adjustment value equals the sum of the fine adjustment values set by the PC command and this parameter.
 The maximum back feed length fine adjustment value is ±9.5mm. When the addition of the values reaches the maximum, the value remains unchanged even if subsequent fine adjustments are made.

- [FEED]** key: Pressing the **[FEED]** key once causes a -0.5mm change, down to -9.5 mm.
- [RESTART]** key: Pressing the **[RESTART]** key once causes a +0.5mm change, up to +9.5 mm.

After completing the fine adjustment, press the **[PAUSE]** key.

A4.5 Printer Parameter Fine Adjustment (Cont.)

X Axis Fine Adjustment

With this parameter you can fine adjust the print position on X Axis. When "<3>ADJUST SET" appears, press the **[PAUSE]** key 4 times.

X Axis Fine Adjustment (Example)

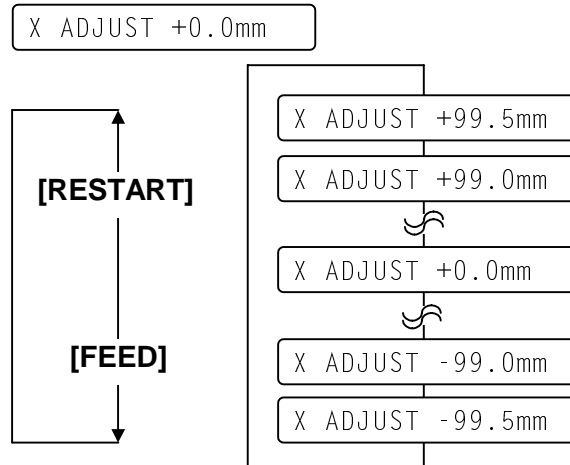
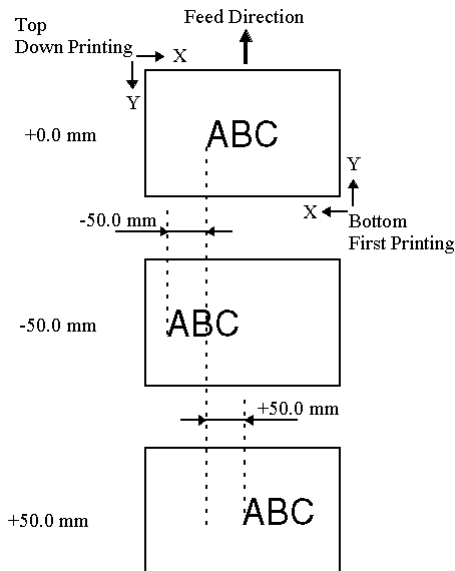

[FEED] key: Pressing the **[FEED]** key once causes a -0.5mm change, down to -99.5 mm.

[RESTART] key: Pressing the **[RESTART]** key once causes a +0.5mm change, up to +99.5 mm.

After completing the fine adjustment, press the **[PAUSE]** key.

NOTES:

1. The X Axis fine adjustment is performed to fine adjust the print position in horizontal direction (left or right).
2. Adjust the X axis within the effective print range. when the value reaches the coordinate 0, the value remains unchanged even if the subsequent negative fine adjustments are made.
3. This adjustment cannot be used in the Self Test mode or Test print.
4. The fine adjustment value equals the sum of the fine adjustment values set by the PC command and this parameter. The maximum X axis fine adjustment value is ±99.5mm. When the addition of values reaches the maximum, the value remains unchanged even if subsequent fine adjustments are made.

A4.5 Printer Parameter Fine Adjustment (Cont.)

NOTES:

- The fine adjustment value equals the sum of the fine adjustment values set by the PC command and this parameter. The maximum print tone fine adjustment value is ±10. The following table shows the maximum fine adjustment value for each print speed. Even if the set value exceeds the maximum value, it will be automatically adjusted to the following value.

Print speed	Thermal Direct	Thermal transfer
4"/sec.	+2 step	
5"/sec.	+5 step	+5 step
8"/sec.	+2 step	+2 step
10"/sec.		+2 step

- This is useful when print density change is required e.g.) If the ribbon is changed to different type.

Print Tone Fine Adjustment (Thermal Transfer/Thermal Direct Print)

With this parameter you can fine adjust the density of the Print Tone. When “<3>ADJUST SET” appears, press the **[PAUSE]** key 5 times to enter the Print Tone Fine Adjustment (Thermal transfer print) menu.

TONE ADJ.<T> +0 Thermal Transfer

To change the screen to the Print Tone Fine Adjustment (Direct Thermal print), press the **[PAUSE]** key again.

TONE ADJ.<D> +0 Thermal Direct

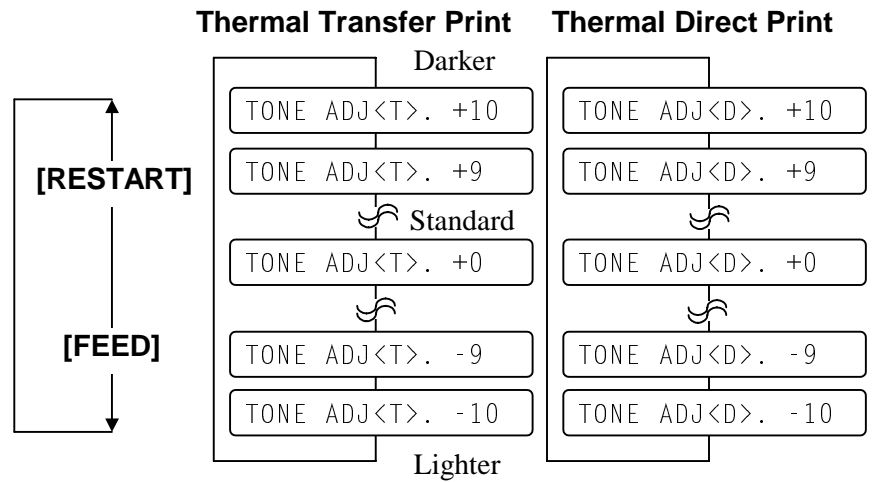

[FEED] key: Pressing the **[FEED]** key once causes a -1 tone change, down to -10 tones.

[RESTART] key: Pressing the **[RESTART]** key once causes a +1 tone change, up to +10 tones.

After completing the fine adjustment, press the **[PAUSE]** key.

A4.5 Printer Parameter Fine Adjustment (Cont.)

NOTES:

1. The fine adjustment value equals the sum of the fine adjustment values set by the PC command and this parameter. The maximum ribbon motor voltage fine adjustment value is -15. When the addition of values reaches the maximum, the value remains unchanged even if subsequent fine adjustments are made.
2. Each step corresponds to 5% of the standard voltage and up to 75% of the voltage can be decreased. Only for the feed motor, the voltage can be increased up to 50%.
3. Please make this adjustment if ribbon errors occurs though the ribbon has not jammed or ended. If the problem cannot be resolved, please contact your nearest TOSHIBA TEC service representative.

Ribbon Motor Voltage Fine Adjustment (Feed/Rewind Motor)

With this parameter you can fine adjust the Ribbon Motor Voltage (Torque). With "<3>ADJUST SET" displayed, press the [PAUSE] key 7 times to enter the Ribbon Motor Voltage Fine Adjustment (Rewind Motor) menu.

RBN ADJ<FW> +0 Rewind Motor

RBN ADJ<FW> +0 Rewind Motor

To change the screen to the Ribbon Motor Voltage Fine Adjustment (Feed Motor), press the [PAUSE] key again.

RBN ADJ<BK> +0 Feed Motor

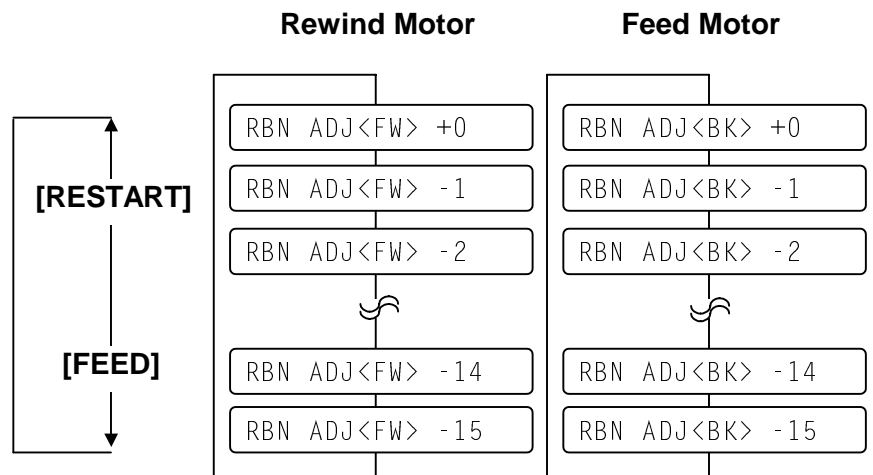

[FEED] key: Pressing the [FEED] key once causes a -1 step change, down to -15 steps.

[RESTART]key: Pressing the [RESTART] key once causes a +1 tone change, up to +0.

After completing the fine adjustment, press the [PAUSE] key.

A4.5 Printer Parameter Fine Adjustment (Cont.)

NOTE:
 This is useful to fine adjust the threshold if problems with media issue persist after the sensor threshold setting is performed. (See Section 6.4 Threshold Setting) If the problem cannot be resolved, please contact your nearest TOSHIBA TEC service representative.

Threshold Manual Fine Adjustment (Black Mark/Feed Gap Sensor)

With this parameter you can fine adjust the Threshold of the Black Mark and Feed Gap Sensors. With “<3>ADJUST SET” displayed, press the [PAUSE] key 9 times to enter the Threshold Manual Fine Adjustment (Black Mark Sensor) menu.

THRESHOLD<R>1.0V Black Mark Sensor

To change the screen to the Threshold Manual Fine Adjustment (Feed Gap Sensor), press the [PAUSE] key again.

THRESHOLD<T>1.4V Feed Gap Sensor

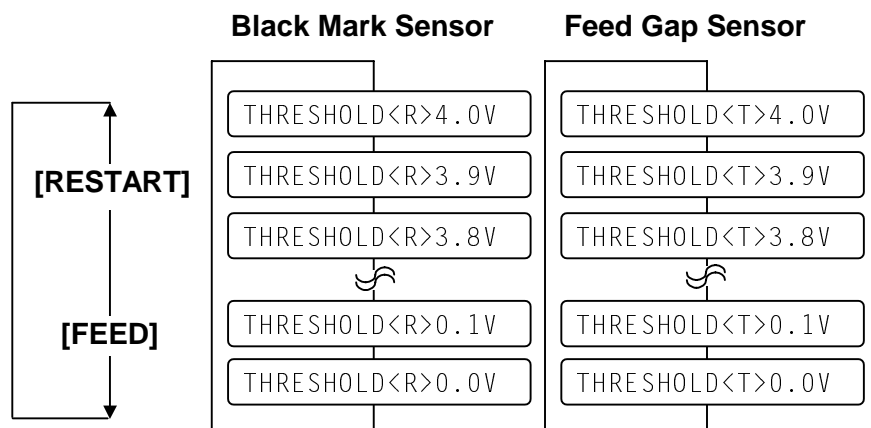

[FEED] key: Pressing the [FEED] key once causes a -0.1V change, down to 0.0V.

[RESTART] key: Pressing the [RESTART] key once causes a +0.1V change, up to +4.0V.

After completing the fine adjustment, press the [PAUSE] key.

NOTE:
 The fine adjustment value equals to the sum of the fine adjustment values set by the PC command and this parameter. The maximum strip motor driving speed fine adjustment value is +4 step. When the addition of the values reaches the maximum, the value remains unchanged even if subsequent fine adjustments are made.

Strip Motor Driving Speed Fine Adjustment

With this parameter you can fine adjust the speed of the backing paper peel motor (stepping motor). With “<3>ADJUST SET” displayed, press the [PAUSE] key 10 times to enter the Strip Motor Driving Speed Fine Adjustment menu.

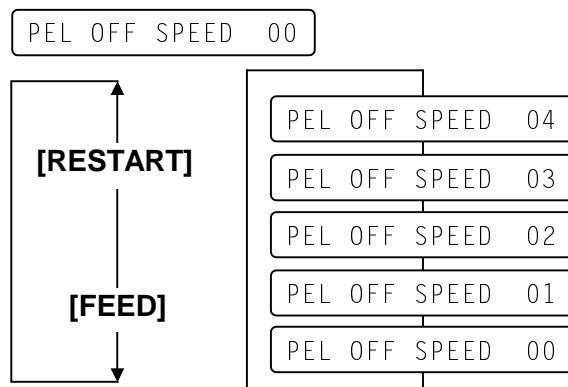

After completing the fine adjustment, press the [PAUSE] key.

A4.6 Test Print

The **Test Print** menu contains the following:

Outline of Test Print

In the Test Print mode, you can print test patterns after setting up some conditions. This is useful for checking the printers operation or for testing the quality of new ribbon or media.

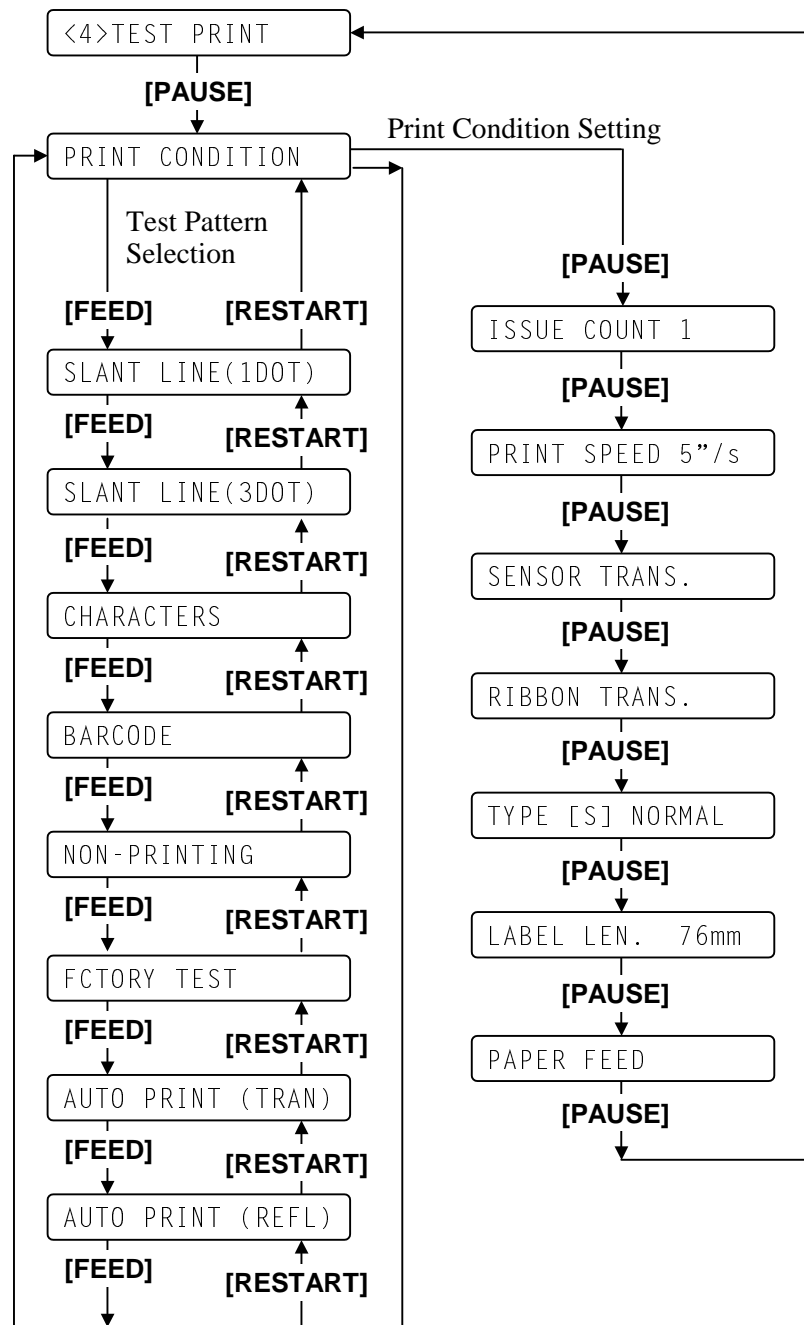

A4.6 Test Print (Cont.)

While in a Pause condition press and hold the **[RESTART]** key until “<0>RESET” appears in the display.

<0>RESET

Then, press the **[FEED]** key four times, and “<4>TEST PRINT” message appears.

<4>TEST PRINT

Specifying the Print Condition for the Test Print

The print conditions for Test Printing should be specified before printing. When “<4>TEST PRINT” appears, press the **[PAUSE]** key.

PRINT CONDITION

Issue Count Setting

To enter the Issue Count Setting menu, press the **[PAUSE]** key.

ISSUE COUNT 1

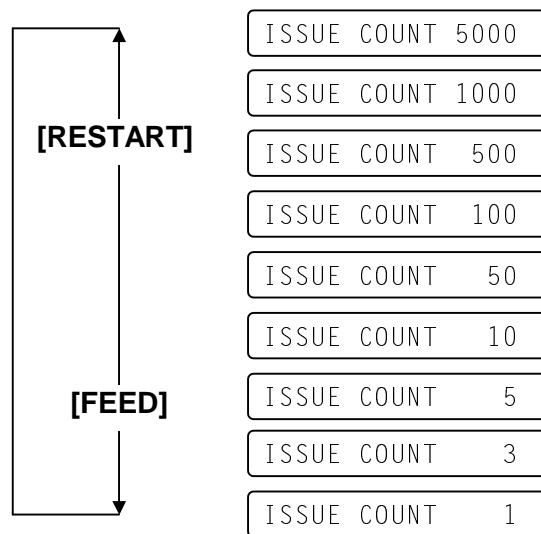

After selecting the issue count, press the **[PAUSE]** key to go to Print Speed Setting.

A4.6 Test Print (Cont.)

Print Speed Setting

Select the print speed for the test print.

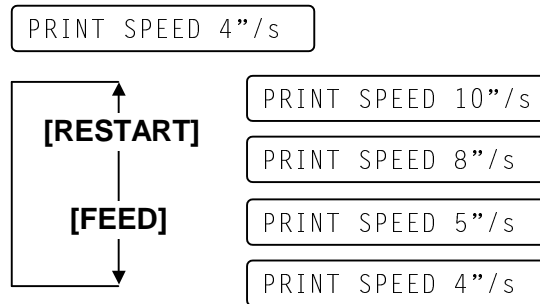

After selecting the print speed, press the **[PAUSE]** key to go to Sensor Type Selection.

Sensor Type Selection

Select the sensor type among “TRANS” (Feed Gap Sensor), “REFLECT” (Black Mark Sensor) and “NONE”.

NOTE:
 Select the sensor type which matches the media being used. Basically, the Reflective Sensor (Black Mark Sensor) is for tag paper, and the Transmissive Sensor (Feed Gap Sensor) is for labels.

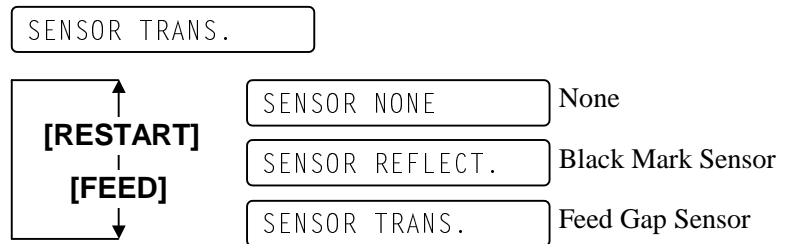

After selecting the sensor type, press the **[PAUSE]** key to go to Ribbon Type Selection.

Ribbon Type Selection

Select the ribbon type for the test print from “NO RIBBON”, “RIBBON TRANS.”, and “NO TRANS.”.

NOTE:
 Select the ribbon type which matches the media and ribbon being used. Basically, the Transmissive and Non Transmissive are for the use with ribbon, and No Ribbon is for use with Direct Thermal paper.

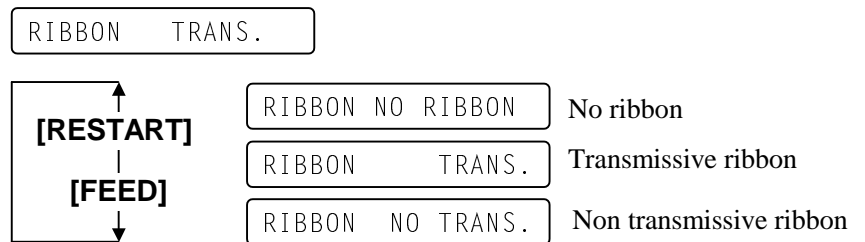

After selecting the printing mode, press the **[PAUSE]** key to go to Issue Mode Selection.

A4.6 Test Print (Cont.)

Issue Mode Selection

Select the issue mode for the test print by selecting between “[S] NORMAL” (Batch mode) and “[H] PEEL OFF” (Strip mode).

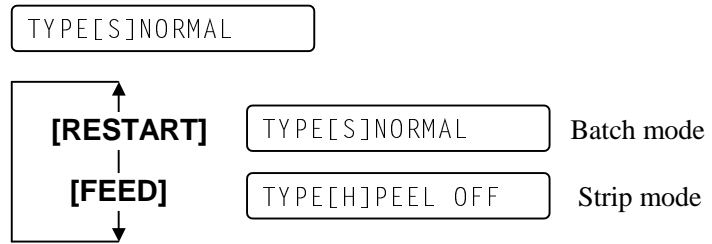

After selecting the Issue Mode, press the **[PAUSE]** key to go to Label Length Setting.

Label Length Setting

Select the label length for the test print in a range from 5 mm to 999 mm.

NOTE:
Press and hold the **[RESTART]** or **[FEED]** key to advance the values quickly and continuously. To stop, release the key.



[FEED] key: Pressing the **[FEED]** key once causes a -1 mm change, down to 5 mm.

[RESTART]key: Pressing the **[RESTART]** key once causes a +1 mm change, up to 999 mm.

After selecting the label length, press the **[PAUSE]** key to go to Paper Feed Selection.

Paper Feed Selection

Select whether or not a paper feed is performed.

NOTE:
When “PAPER FEED” is selected, the printer feeds the media to the correct print start position for the selected conditions.
When “PAPER NO FEED” is selected, the printer makes no pre-feed to set the print start position. If the print start position adjustment is unnecessary, Select "PAPER NO FEED" and save media.

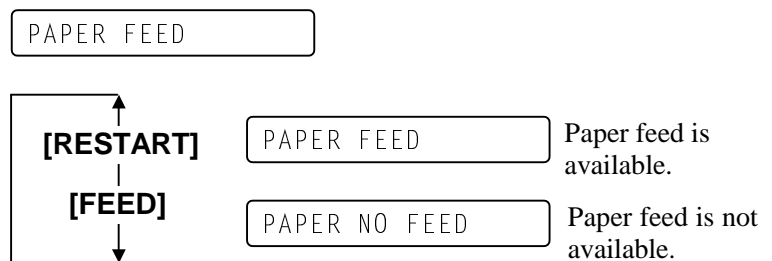

After selecting the paper feed, press the **[PAUSE]** key. If "PAPER FEED" was selected the printer will feed the media. The display returns to the “<4>TEST PRINT”.

A4.6 Test Print (Cont.)

Test Print Pattern Selection

With “<4>TEST PRINT” displayed after paper feed selection, press the **[PAUSE]** key.

PRINT CONDITION

Select a test print pattern from the following options.

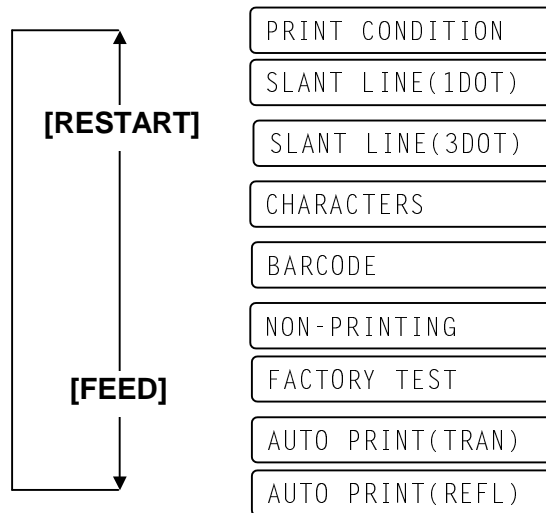

Print Sample of Slant Line (1 dot)

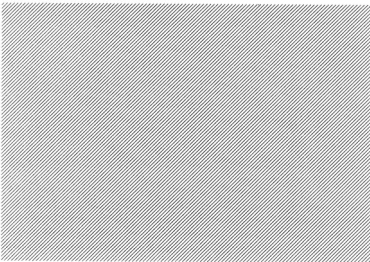

Print Sample of Slant Line (3 dots)

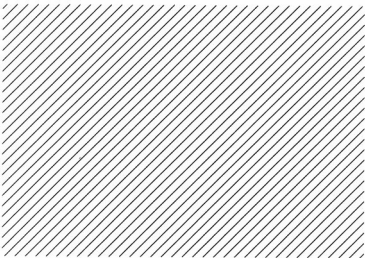

Slant Line (1 dot)

SLANT LINE(1DOT)

While displaying Slant Line (1 dot), press the **[PAUSE]** key to start printing the slant line patterns (1 dot). After printing is completed, the display returns to “<4>TEST PRINT”.

Pressing the **[PAUSE]** key causes the display to show “SLANT LINE (1DOT)” again. Then, press the **[FEED]** key.

Slant Line (3 dots)

SLANT LINE(3DOT)

While displaying the Slant Line (3 dots), press the **[PAUSE]** key to start printing the slant line patterns (3 dots). After printing is completed, the display returns to “<4>TEST PRINT”.

Pressing the **[PAUSE]** key causes the display to show “SLANT LINE (3DOT)” again. Then, press the **[FEED]** key.

NOTE:
See A4.8.3 for further information.

A4.6 Test Print (Cont.)

Print Sample of Characters

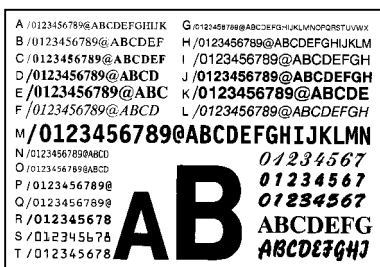

Print Sample of Barcodes



NOTE:

The Non-Printing function looks like a media feed.

Print Sample of Non-print

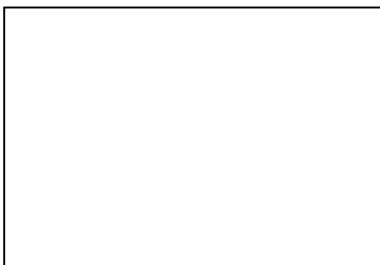

NOTES:

- Factory test print conditions:
 One paper feed, Slant lines (3 dots), Bar codes, Characters, Item count: 5 pcs. each, Print speed: 5"/sec., Sensor type: Black or Feed gap sensor
 Ribbon type: Transparent
- When the feed gap sensor is selected, a gap length is 3 mm.
 Print method: Thermal transfer, Issue mode: Batch printing, Label length: 76 mm, Print tone fine adjustment.

Characters



While displaying the Characters, press the **[PAUSE]** key to start printing the characters. After printing is completed, the display returns to "<4>TEST PRINT".

Pressing the **[PAUSE]** key causes the display to show "CHARACTERS" again. Then, press the **[FEED]** key.

Barcode

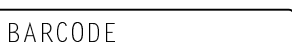

While displaying the Barcode, press the **[PAUSE]** key to start printing the bar codes. After printing is completed, the display returns to "<4>TEST PRINT".

Pressing the **[PAUSE]** key causes the display to show "BARCODE" again. Then, press the **[FEED]** key.

Non-Printing



While displaying the Non-printing, press the **[PAUSE]** key to start issuing a blank page of media. After printing is completed, the display returns to "<4>TEST PRINT".

Pressing the **[PAUSE]** key causes the display to show "NON-PRINTING" again. Then, press the **[FEED]** key.

Factory Test



While displaying the Factory test, press the **[PAUSE]** key to start printing the factory test pattern. After printing is completed, the display returns to "<4>TEST PRINT".

Pressing the **[PAUSE]** key causes the display to indicate "FACTORY TEST" again. Then, press the **[FEED]** key.

A4.6 Test Print (Cont.)

Auto Print

NOTE:
Select "AUTO PRINT (TRAN)" when using labels, and "AUTO PRINT (REFL)" when using tag paper.

AUTO PRINT(TRAN)

Feed Gap Sensor

AUTO PRINT(REFL)

Black Mark Sensor

While displaying Auto Print, press the **[PAUSE]** key to feed one piece of media and print slant lines (3 dots) on 5 pieces of media. Next, press the **[PAUSE]** key to print bar codes on 5 pieces of media. Pressing the **[PAUSE]** key again causes the printer to print characters on 5 pieces of media.

A4.7 Dump Mode

In Dump mode, any characters sent from the host computer will be printed. Received characters are expressed in hexadecimal values. This allows the user to verify programming commands and debug their program.

And for other details, please refer to your nearest TOSHIBA TEC service representative.

A4.8 Additional Information

A4.8.1 Self-Diagnostic Test Result Sample and Descriptions

• **Print Sample**

(1)	PROGRAM	B-492	20SEP2001
		V1.0A	FMRM0067001: 1A00
(2)	BOOT	B-492	01SEP2001
		V1.0	FMRM0066901:8500
(3)	FONT	5600	
(4)	EEPROM	OK	
(5)	SDRAM	8MB	
(6)	CARD	SLOT1	ATA
		SLOT2	LAN
(7)	SENSOR	[H]20°C [A]22°C [S]25°C	
		[R]4.2V [T]2.5V	
		[RANK]7	
(8)	DIP SW	1: ON	2: OFF 3: OFF
(9)	EXP.I/O	NG	
(10)	KEY BRD	NG	

NOTES:

1. *Print conditions:*
 Preset count: 1, Print speed: 5"/sec., Sensor: No sensor, Printing method: Thermal transfer,
 Supply length: 59 mm, Issue mode: Batch printing
2. *Software version No., Part No. of ROM and checksum will vary with the software version of PROGRAM ROM.*
3. *The last two digits of the checksum are usually "00".*
4. *The symbol "°" of "°C" may not be printed depending on the type of character code selected.*

• **Descriptions**

(1) Program ROM Check (Model Name, Date, Version, Part number, Checksum)

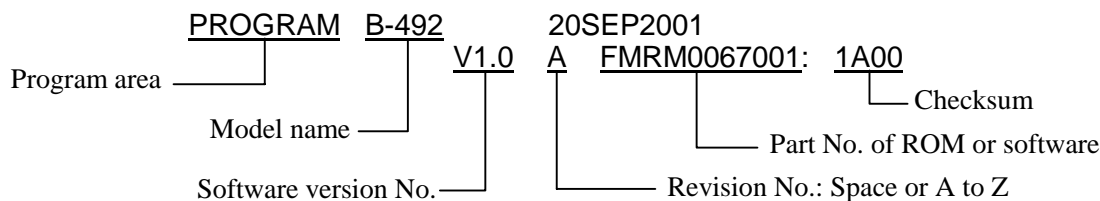

(2) Boot Check (Model Name, Date, Version, Part Number, Checksum)

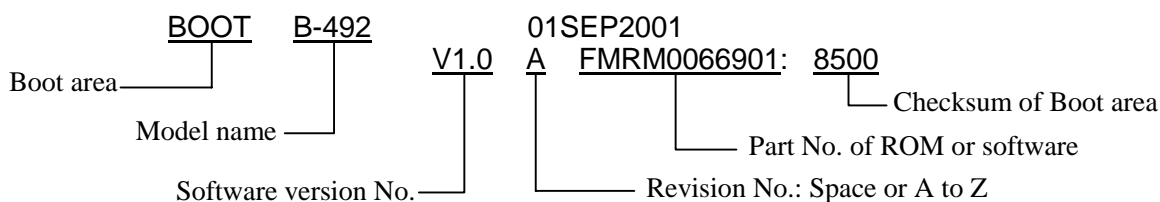

A4.8.1 Self-Diagnostic Test Result Sample and Descriptions (Cont.)

(3) Alphanumeric Font ROM Check

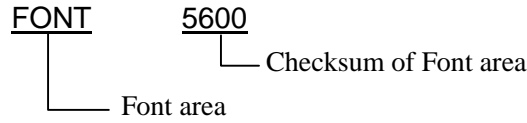

(4) EEPROM Check

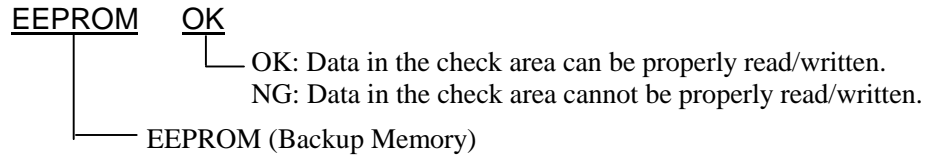

(5) SDRAM Capacity

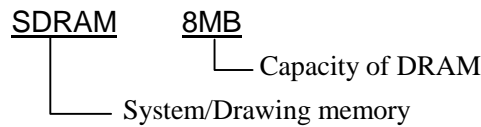

(6) PC Card Slot Check

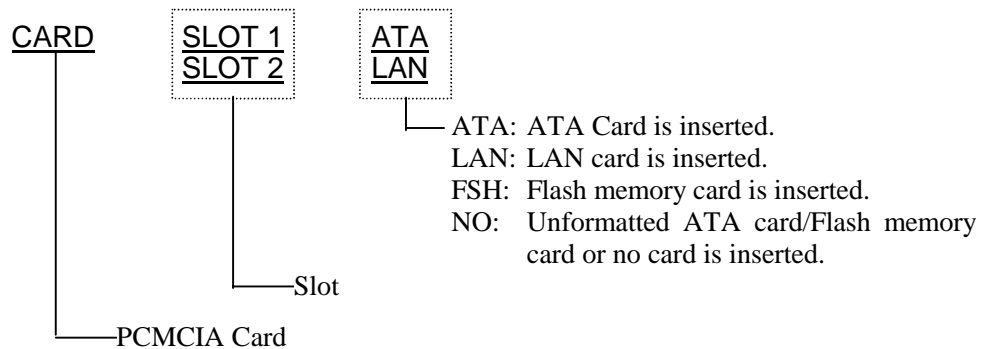

(7) Sensor Check

The status of the Print Head Thermistor, Environmental Temperature Thermistor, Heat Sink Thermistor, Black Mark Sensor, Feed Gap Sensor, and Print Head Resistance Rank are printed on this line.

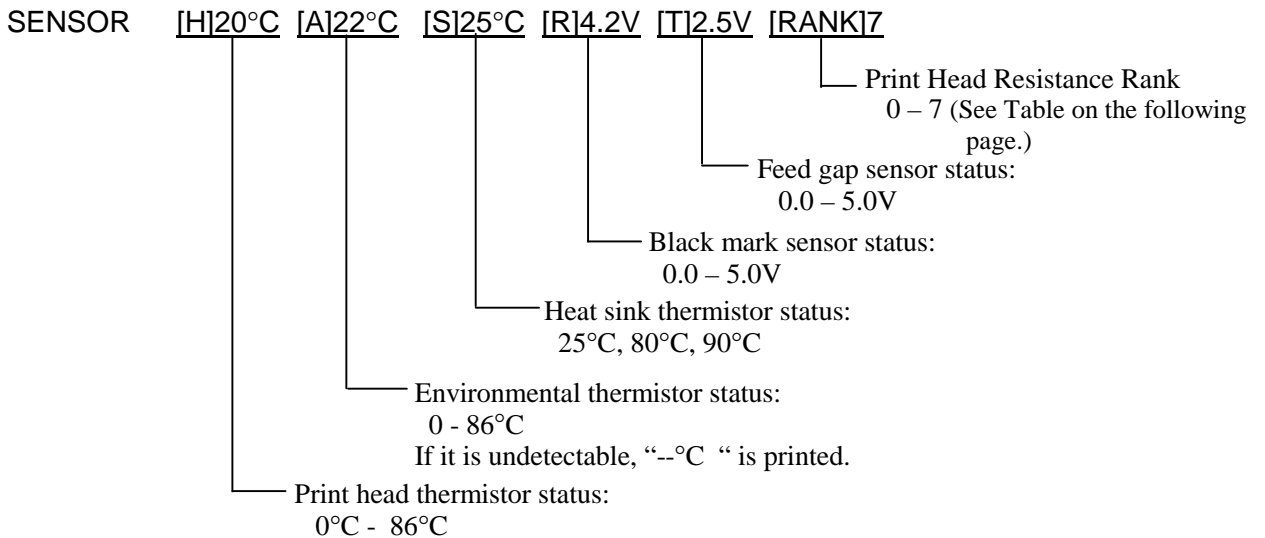

A4.8.1 Self-Diagnostic Test Result Sample and Descriptions (Cont.)

Print Head Resistance Rank Table

Rank	Average resistance (ohm)	Rank	Average resistance (ohm)
0	1409 to 1454	4	1219 to 1265
1	1361 to 1408	5	1171 to 1218
2	1314 to 1360	6	1124 to 1170
3	1266 to 1313	7	1076 to 1123

(8) DIP Switch Status

DIP SW 1: ON 2: OFF 3: OFF

(9) Expansion I/O Interface Check

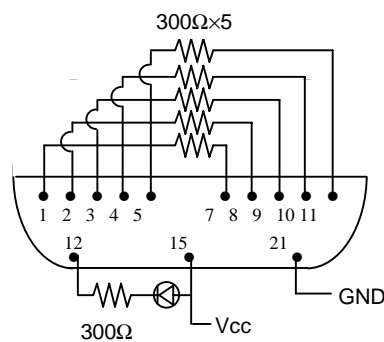
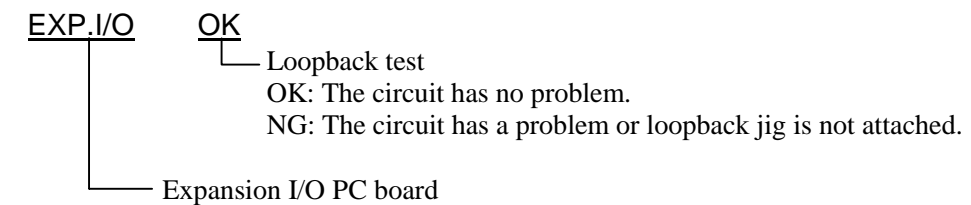

Connector: FCN-781P024-G/P

(10) DIN Connector for the Keyboard (KB-80) Check

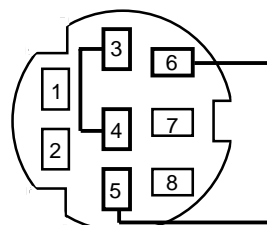
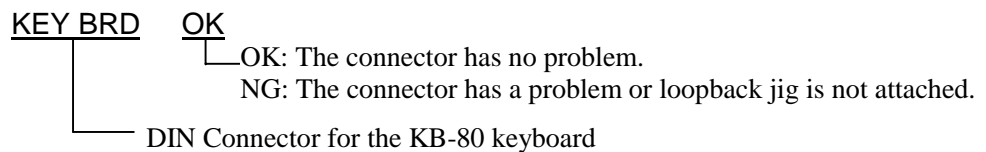

DIN Connector: TCS7588-01-201
 Pin 3 and Pin 4 are short-circuited.
 Pin 5 and Pin 6 are short-circuited.

A4.8.2 Maintenance Counter and Parameter Check Print Sample and Descriptions

- **Print Sample**

(1)	TOTAL FEED	1.1Km
(2)	FEED	1.1Km
(3)	PRINT	0.5Km
(4)	HEAD U/D	32
(5)	RIBBON	3h
(6)	SOLENOID	0h
(7)	232C ERR	255
(8)	SYSTEM ERR	0
(9)	POWER FAIL	0
	[PC]	[KEY]
(10)	FEED +2.0mm	FEED +0.0mm
(11)	PEEL OFF +0.0mm	PEEL OFF +1.0mm
(12)	BACK +0.0mm	BACK +0.0mm
(13)	TONE(T) +0 step	TONE(T) +0 step
(14)	TONE (D) +0 step	TONE(D) +0 step
(15)	RBN(FW) -10	RBN (FW) -8
(16)	RBN (BK) +0	RBN (BK) +0
(17)	PO SPEED +0	PO SPEED +0
(18)	X ADJ. +0.0mm	
(19)	THRESHOLD (R)	1.0V
(20)	THRESHOLD (T)	1.4V
(21)	FONT	[PC-850] [0]
(22)	CODE	[AUTO]
(23)	RIBBON	[TRANS]
(24)	SPEED	[9600]
(25)	DATA LENG.	[8]
(26)	PARITY	[EVEN]
(27)	CONTROL	[XON+READY AUTO]
(28)	MESSAGE	[ENGLISH]
(29)	RIBBON SAVE	[ON]
(30)	FEED KEY	[FEED]
(31)	EURO CODE	[B0]
(32)	AUTO HD CHK	[OFF]
(33)	ACK/BUSY	[TYPE1]
(34)	WEB PRINTER	[OFF]
(35)	KB80 CONNECT	[OFF]
(36)	RIBBON NEAR END	[30m]
(37)	PRTR IP ADDRESS	[192.168.010.020]
(38)	GATE IP ADDRESS	[000.000.000.000]
(39)	SUBNET MASK	[255.255.255.000]
(40)	TTF AREA	[704kB]
(41)	EXT CHR AREA	[128kB]
(42)	PC SAVE AREA	[64kB]
(43)	SOCKET PORT	[OFF] [08000]

NOTE:

Print conditions:

*Preset count: 1, Print speed: 5"/sec., Sensor: No sensor, Printing mode: Thermal transfer,
Media length: 170 mm, Issue mode: Batch printing*

A4.8.2 Maintenance Counter and Parameter Check Print Sample and Descriptions (Cont.)

• Descriptions of the Maintenance Counter

No.	Item	Count Condition	Range
(1)	Total media distance covered	Counted when the feed motor is driven to feed, print and issue the media. (Also counted during back feed.) <i>See NOTE 6.</i>	0.0 to 2000.0 km
(2)	Media distance covered		0.0 to 181.9 km
(3)	Print distance	Counted while printing. (Back feeding is not counted.) <i>See NOTE 2.</i>	0.0 to 200.0 km
(4)	Head up/down count	Counts every print head up and down movement using the ribbon saving solenoid. (Up + down=1 count) <i>See NOTE 3.</i>	0 to 2000000 times
(5)	Ribbon motor operating time	Counts when the ribbon motor is driven to feed, print and issue media. (The driving time is also counted during back feed.) <i>See NOTE 4.</i>	0 to 2000 hours
(6)	Head up solenoid operating time	Counted during the ribbon saving. <i>See NOTE 4.</i>	0 to 1000 times
(7)	RS-232C hardware error count	Counted when a parity, overrun or framing error occurs. <i>See NOTE 5.</i>	0 to 255 times
(8)	System error count	Counted when any error occurs.	0 to 15 times
(9)	Momentary power failure count	Counts the number of times the power restores while the CPU is busy after reset.	0 to 15 times

NOTES:

1. The item from (2) through (9) are initialized to "0" after RAM clear.
2. If the Print distance is 5.5m or less, it is rounded down and no data is added to the memory at power off.
3. If the count is 31 counts or less, it is rounded down and no data is added to the memory at power off.
4. If the driving time is 27 sec. or less, it is rounded down and no data is added to the memory at power off.
5. When more than 1 byte-data is continuously sent, they are counted by byte.
6. If the media distance covered is 69.4 cm or less, it is rounded down and no data is added to the memory at power off.

• Descriptions of the Parameters

No.	Item	Contents
(10)	Feed length fine adjustment (PC), (KEY)	-50.0 mm to +50.0 mm
(11)	Strip position fine adjustment (PC), (KEY)	-50.0 mm to +50.0 mm
(12)	Back feed length fine adjustment (PC), (KEY)	-9.9 mm to +9.9 mm
(13)	Print tone fine adjustment (Thermal transfer), (PC), (KEY)	-10 step to +10 step
(14)	Print tone fine adjustment (Thermal direct), (PC), (KEY)	-10 step to +10 step
(15)	Ribbon rewind motor driving voltage fine adjustment (PC), (KEY)	-15 step to +0 step
(16)	Ribbon feed motor driving voltage fine adjustment (PC), (KEY)	-15 step to +0 step
(17)	Strip Motor driving speed fine adjustment (PC), (KEY)	+0 to +4
(18)	X axis fine adjustment	-99.5 mm to +99.5 mm

A4.8.2 Maintenance Counter/Parameter Check Print Sample and Descriptions (Cont.)

No.	Item	Contents
(19)	Threshold manual fine adjustment for the black mark sensor	0.0V to 4.0V
(20)	Threshold manual fine adjustment for the feed gap sensor	0.0V to 4.0V
(21)	Character	PC-850 PC-851 PC-1252 LATIN9 PC-852 PC-855 PC-1253 Arabic PC-857 PC-1250 PC-1254 PC-8 PC-1251 PC-1257
	Font zero	0: No slash used. Ø: Slash used.
(22)	Control code	AUTO: Automatic selection ESC LF NUL: ESC LF NUL mode { }: Mainframe mode 1B 1C 1D: Manual
(23)	Ribbon type	NO RIBBON: No ribbon TRANS: Transparent ribbon end NON TRANS: Opaque ribbon end
(24)	Baud rate	2400: 2400 bps 9600: 9600 bps 4800: 4800 bps 19200: 19200 bps 38400: 38400 bps
(25)	Data length	7: 7 bits 8: 8 bits
(26)	Parity	NON: None ODD: ODD EVEN: EVEN
(27)	Transmission control code	XON/XOFF: XON/XOFF READY/BUSY: READY/BUSY (DTR) XON+READY AUTO: XON/XOFF+READY/BUSY (DTR) XON/XOFF AUTO: XON/XOFF READY/BUSY RTS: RTS
(28)	Language selection for LCD message	ENGLISH: English GERMAN: German FRENCH: French DUTCH: Dutch SPANISH: Spanish JAPANESE: Japanese ITALIAN: Italian
(29)	Ribbon saving function	ON: Use OFF: Non use
(30)	Feed key function	FEED: Feeds one label PRINT: Prints image buffer on one label
(31)	Euro font code	20H to FFH
(32)	Auto print head broken element check	ON: Available OFF: Unavailable

A4.8.2 Maintenance Counter/Parameter Check Print Sample and Descriptions (Cont.)

No.	Item	Contents
(33)	Centronics ACK/BUSY timing setting	TYPE1: ACK is output when canceling BUSY. TYPE2: ACK is output after canceling BUSY.
(34)	Web printer function	ON: Available OFF: Unavailable
(35)	KB-80 keyboard connection	ON: Connect OFF: Not connect
(36)	Ribbon near end detection	30m: Warning when the remaining ribbon length is about 30 m. 70m: Warning when the remaining ribbon length is about 70 m.
(37)	Printer IP address	***.***.***.***
(38)	Gateway IP address	***.***.***.***
(39)	Subnet mask	***.***.***.***
(40)	True type font registration area size	0 KB to 896 KB (unit of 64 KB)
(41)	External character registration area size	0 KB to 896 KB (units of 64 KB)
(42)	PC saving area size	0 KB to 896 KB (units of 64 KB)
(43)	Socket communication setting and port number	ON: Communicable OFF: Not communicable Port No.: 0 -065535

A4.8.3 Magnified Views of Slant Line Pattern

- 1-dot Slant Line (Black Area Ratio: 16.7%)

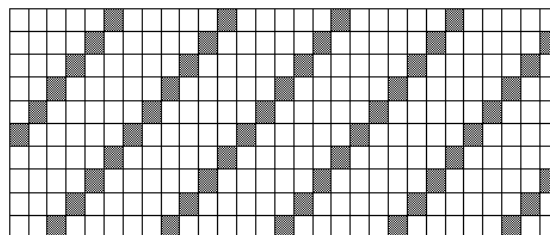

- 3-Dot Slant Line (Black Area Ratio: 16.7%)

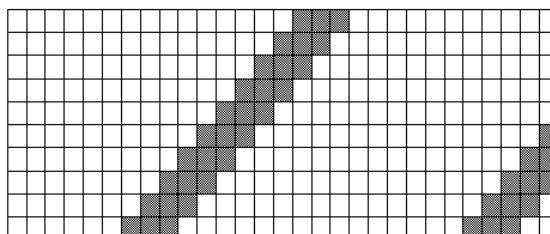

APPENDIX 5 PRINT SAMPLES

■ Font

<A>Times Roman medium:8point

Times Roman medium:10point

<C>Times Roman bold:10point

<D>Times Roman bold:12point

<E>Times Roman bold:14point

<F>Times Roman italic:12point

<G>Helvetica medium:6point

<H>Helvetica medium:10point

<I>Helvetica medium:12point

<J>Helvetica bold:12point

<K>Helvetica bold:14point

<L>Helvetica italic:12point

<M>PRESENTATION BOLD:18POINT

<N>Letter Gothic medium:9.5point

<O>Prestige Elite medium:7point

<P>Prestige Elite bold:10point

<Q>Courier medium:10point

<R>Courier bold:12point

<S>OCR-A:12point

<T>OCR-B:12point

<Outline Font:B>Helvetica bold

APPENDIX 5 PRINT SAMPLES (Cont.)

■ Bar codes

0: JAN8, EAN8



1: MSI



2: Interleaved 2 of 5



3: CODE39 (Standard)



4: NW7



5: JAN13, EAN13



6: UPC-E



7: EAN13+2 digits



8: EAN13+5 digits



A: CODE128



B: CODE39 (Full ASCII)



C: CODE93



G: UPC-E+2 digits



H: UPC-E+5 digits



I: EAN8+2 digits



J: EAN8+5 digits



APPENDIX 5 PRINT SAMPLES (Cont.)

K: UPC-A



L: UPC-A+2 digits



M: UPC-A+5 digits



N: UCC/EAN128



O: Industrial 2 of 5



P: PDF417



Q: Data Matrix



R: Customer bar code



S: Customer bar code of high priority



T: QR code



U: POSTNET



V: RM4SCC



W: KIX Code



X: Micro PDF417



Z: MaxiCode

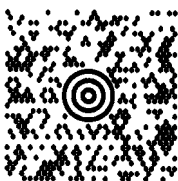

GLOSSARIES

Bar code

A code which represents alphanumeric characters by using a series of black and white stripes in different widths. Bar codes are used in various industrial fields: Manufacturing, Hospitals, Libraries, Retail, Transportation, Warehousing, etc. Reading bar codes is a fast and accurate means of capturing data while keyboard entry tends to be slow and inaccurate.

Batch mode

Issue mode that continuously prints media until the required number has been printed.

Black mark

A mark printed on the media enabling the printer to detect the correct start position of the media, helping to maintain constant print position.

Black mark sensor

A reflective sensor that detects the difference between a black mark and the print area to find the print start position.

DPI

Dots Per Inch

A unit used to express print density or resolution.

Expansion I/O interface

This interface allows the printer to be connected to an external device such as an applicator and to receive feed, print start, and pause signals from that device and to send back print, pause, and error status signals to the external device.

Feed gap sensor

A transmissive sensor that detects the difference between the gap between labels and the label itself, to find the print start position of the label.

Font

A complete set of alphanumeric characters in one style of type. E.g. Helvetica, Courier, Times

Gap

Distance from the bottom of one label to the top of the next

IPS

Inchs per second

A unit used to express print speed.

KB-80 keyboard interface

This interface allows the B-492L/R printer to connect to the optional KB-80 keyboard providing it with a standalone capability. Label programs may be stored in the KB-80 flash memory and labels can be printed using data input through the keyboard instead of from a host computer.

LCD

Liquid Crystal Display

Installed on the operation panel and displays operation modes, error messages and so on.

Label

A type of media with adhesive backing supplied on a backing paper.

Media

Material on which images are printed by the printer. Label, tag paper, fanfold paper, perforated paper, etc.

PCMCIA interface

An optional interface board that may be installed in the B-492L/R printer to allow the use of the small credit card sized PC cards such as flash memory cards and LAN cards. PCMCIA is the acronym for Personal Computer Memory Card International Association.

Printer driver

A software program that will convert the application program's printing request into the language that the printer understands.

Print head element

The thermal print head consists of a single line of tiny resistive elements which when current is allowed to flow through them it heats up causing a small dot to be burned onto thermal paper or a small dot of ink to be transferred from a thermal ribbon to ordinary paper.

Pre-printed label

A type of label on which characters, logos, and other designs have been already printed.

Printing speed

The speed at which printing occurs. This speed is expressed in units of IPS (inches per second).

Reflective sensor

See Black mark sensor.

Resolution

The degree of detail to which an image can be duplicated. The minimum unit of divided image is called a pixel. As the resolution becomes higher, the number of pixels increases, resulting in a more detailed image.

Ribbon

An inked film used to transfer an image onto the media. In thermal transfer printing, it is heated by the thermal print head, causing an image to be transferred onto the media

Supply

Media and ribbon

Thermal direct printing

A printing method using no ribbon, but thermal media which reacts to heat. The thermal print head heats the thermal media directly, causing print image to be printed on the media.

Thermal print head

A print head using thermal transfer or thermal direct printing method..

Thermal transfer printing

A printing method that uses the thermal print head to heat an ink or resin coating on the ribbon against the media, causing the ink/resin to transfer onto the media.

Threshold setting

A sensor setting operation to help the printer maintain a constant print position on pre-printed media. .

Transmissive sensor

See Feed gap sensor.

X Axis

In the printer, it is the horizontal position (left and right) of the print on the label. This position may be adjusted by command from the host computer, or by a parameter change on the printer.

INDEX

B

Backing paper 2-9, A1-3
Bar code A1-1, A4-19, A5-2
Batch mode 2-9
Black mark 2-8, A1-2
Black mark length A1-3
Black mark sensor 2-8, A4-13

C

Centronics 1-3, 2-2, 2-3, A1-1

D

Dimensions 1-2, 1-5, A1-1
DC Power Connector 1-3, 1-5
DC Power Cable 2-4

E

Effective print range A1-4
ERROR LED 1-4, 3-1
Error message 5-1
Expansion I/O interface 1-3, 2-3, A1-1

F

Fan filter 2-2
Feed gap sensor 2-8, A4-13
FEED key 1-4, 3-1
Flash memory card 2-13, A1-2

G

Gap between labels 2-8, A1-3
Gap length A1-3
Guaranteed print area A1-4

H

Head lever 1-4, 2-6

I

Interface A1-1
Issue mode 2-9, A4-17

J

Jammed media 5-1, 5-3

K

KB-80-QM keyboard 1-1, 2-3
Keyboard interface 1-3, 2-3, A1-1
Keyboard module A1-2

L

Label A1-2
Label length A1-3
Label pitch A1-3
Label width A1-3
LCD message display 1-4, 3-1, A1-1

M

Maintenance counter A4-24
Media 4-5, A1-2
Media guide plate 4-2

O

ONLINE LED 1-4, 3-1
Operation Panel 1-3, 1-4, 3-1

P

Parallel interface 1-3, 2-3, A1-1
Parallel port 2-3
PAUSE key 1-4, 3-1
PCMCIA card 2-12
PCMCIA interface board 2-12, A1-2
Platen 4-1
Power consumption A1-1
Power cord 1-1, 2-4
POWER LED 1-4, 3-1
Power supply unit 1-5
Power switch 2-4, 2-5
Pre-printed label 5-3
Printer driver 6-1
Printer parameter A4-2, A4-6
Print head 1-3, 4-1
Print head element 4-1, A4-5
Printing method A1-1
Printing speed A1-1

R

Reflective sensor A1-4
Resolution A1-1
RESTART key 1-4, 3-1
Ribbon 2-11, 4-5, A1-5
Ribbon width A1-5
Rotation A1-1
RS-232C 1-3, 2-2, 2-3, A1-1, A3-1

S

Self diagnostic test A4-2, A4-3, A4-21
Sensor 2-8, 5-1
Serial interface 1-3, 2-3, A1-1, A3-1
Supply voltage A1-1

T

Test print 2-13, A4-14
Thermal direct A1-1
Thermal transfer A1-1
Threshold setting 5-3
Transmissive sensor A1-3
Two dimensional code A1-1

W

Weight A1-1



TEC
TOSHIBA TEC CORPORATION

E PRINTED IN JAPAN
EO1-33032

Free Manuals Download Website

<http://myh66.com>

<http://usermanuals.us>

<http://www.somanuals.com>

<http://www.4manuals.cc>

<http://www.manual-lib.com>

<http://www.404manual.com>

<http://www.luxmanual.com>

<http://aubethermostatmanual.com>

Golf course search by state

<http://golfingnear.com>

Email search by domain

<http://emailbydomain.com>

Auto manuals search

<http://auto.somanuals.com>

TV manuals search

<http://tv.somanuals.com>