

General Precautions for Installation/Service/Maintenance for the KK-1600

The installation and service should be done by a qualified service technician.

1. When installing the KK-1600 to the Plain Paper Copier, be sure to follow the instructions described in the "Unpacking/Set-Up Procedure for the KK-1600" booklet which comes with each unit of the KK-1600.
2. The KK-1600 should be installed by an authorized/qualified person.
3. Before starting installation, servicing or maintenance work, be sure to turn off and unplug the copier first.
4. When servicing or maintaining the KK-1600, be careful about the rotating or operation sections such as gear, pulleys, sprockets, cams, belts, etc.
5. When parts are disassembled, reassembly is basically the reverse of disassembly unless otherwise noted in this manual or other related materials. Be careful not to reassemble small parts such as screws, washers, pins, E-rings, toothed washers to the wrong places.
6. Basically, the machine should not be operated with any parts removed or disassembled.
7. Delicate parts for preventing safety hazard problems (such as breakers, thermofuses, fuses, door switches, sensors, etc. if any) should be handled/installed/adjusted correctly.
8. Use suitable measuring instruments and tools.
9. During servicing or maintenance work, be sure to check the serial No. plate and other cautionary labels (if any) to see if they are clean and firmly fixed. If not, take appropriate actions.
10. The PC board must be stored in an anti-electrostatic bag and handled carefully using a wristband, because the ICs on it may be damaged due to static electricity. Before using the wrist band, pull out the power cord plug of the copier and make sure that there is no uninsulated charged objects in the vicinity.
11. For the recovery and disposal of used KK-1600, consumable parts and packing materials, it is recommended that the relevant local regulations/rules should be followed.
12. After completing installation, servicing and maintenance of the KK-1600, return the KK-1600 to its original state, and check operation.

Copyright 2000

TOSHIBA TEC CORPORATION

CONTENTS

1. SPECIFICATIONS	1-1
2. OUTLINE	2-1
2.1 Names of Various Components	2-1
2.2 Layout of Electrical Parts	2-2
2.3 Harness Connection Diagram	2-4
2.4 Board Assembly	2-5
3. OPERATIONAL DESCRIPTION	3-1
3.1 General Description	3-1
3.2 Block Diagram	3-1
3.3 Detection of Abnormal Status	3-2
3.4 Flow Chart	3-3
4. MECHANICAL DESCRIPTION	4-1
4.1 Mechanism Drawing	4-1
4.2 Staple Operation	4-1
5. CIRCUIT DESCRIPTION	5-1
5.1 PWA Block Diagram	5-1
5.2 Functional Description	5-1
5.3 Signal Description	5-2
5.4 Timing Charts	5-3
6. DISASSEMBLY AND REPLACEMENT	6-1

1. SPECIFICATIONS

Type of stapling	: Flat clinch method
No. of sheets stapled	: 52g/m ² paper, 2 sheets to 80g/m ² paper, 50 sheets 52g/m ² paper, 2 sheets to 80g/m ² paper, 48 sheets + 200g/m ² , 2 sheets Paper thickness : Max. 5.5 mm
Staple capacity	: 5000 staples
Dimensions	: 257 (W) x 423 (D) x 173 (H) mm
Weight	: Approx. 3.4 kg
Power supply	: 100V - 240V (Supplied from copier)

2. OUTLINE

2.1 Names of Various Components

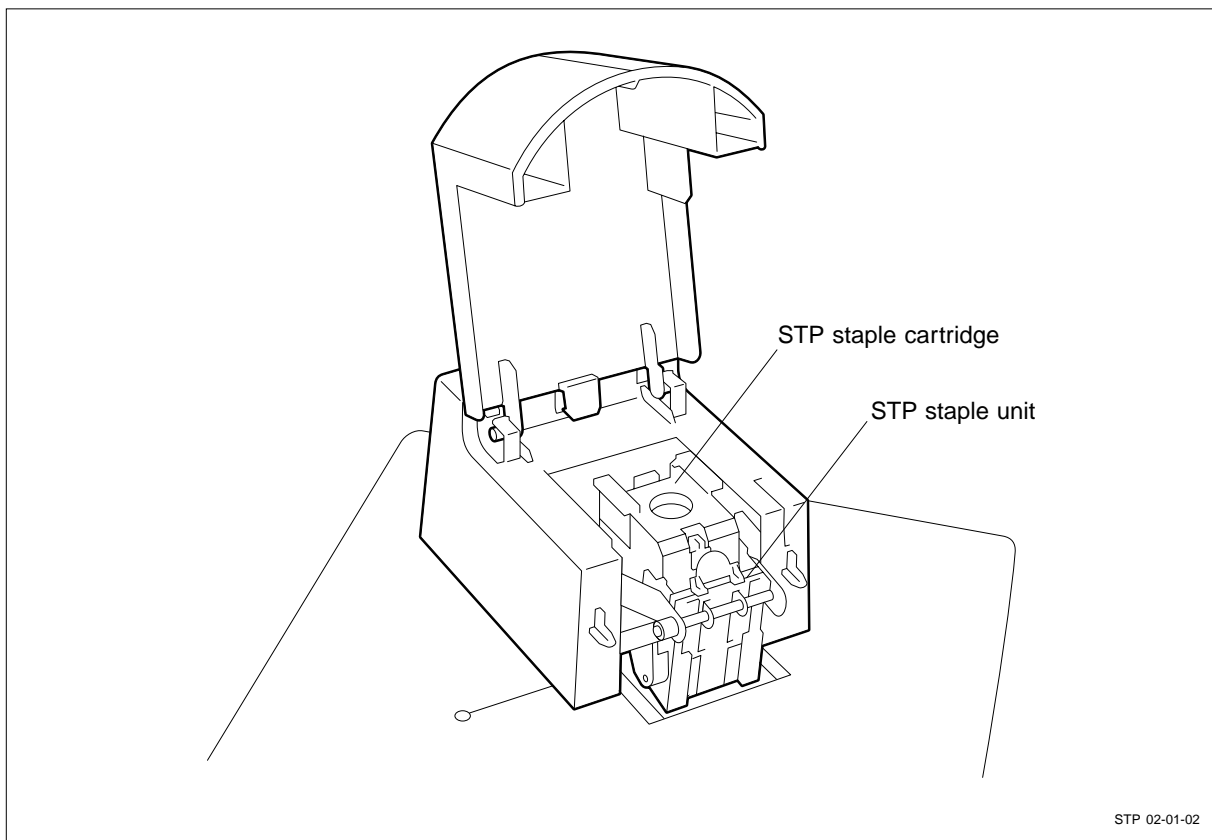
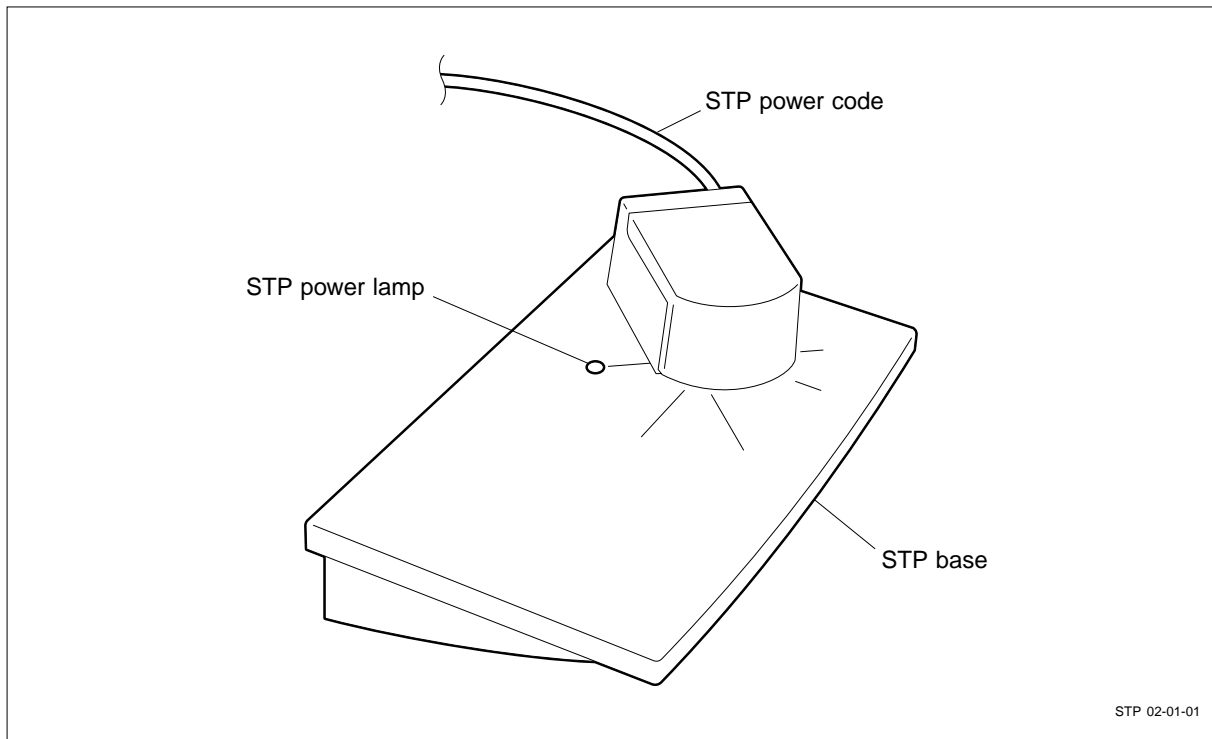

2.2 Layout of Electrical Parts

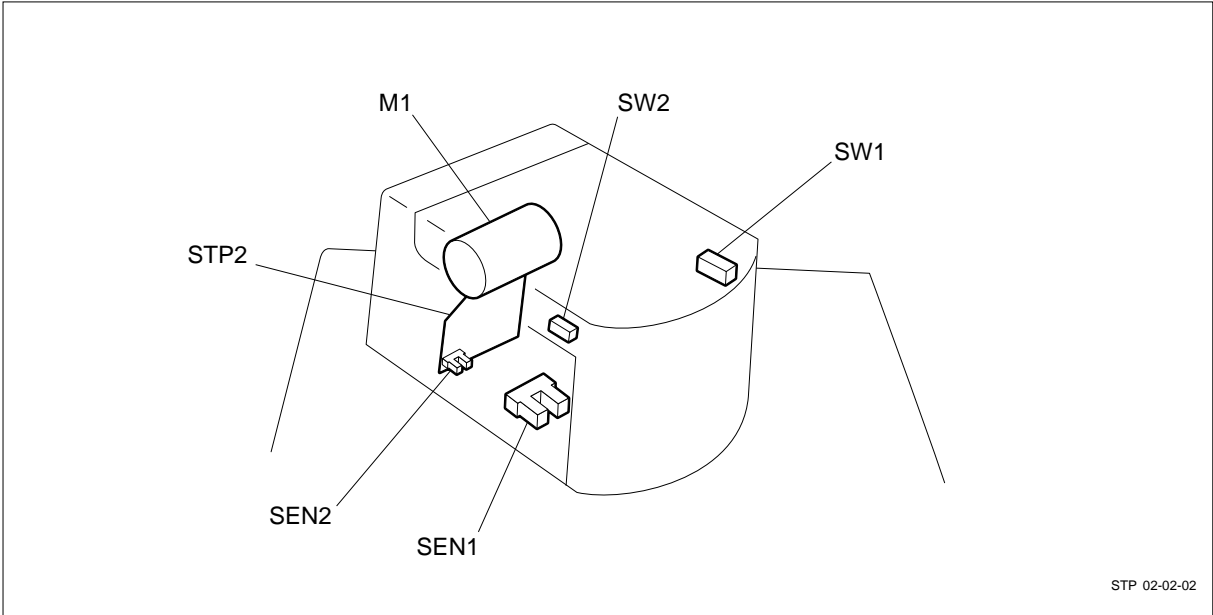
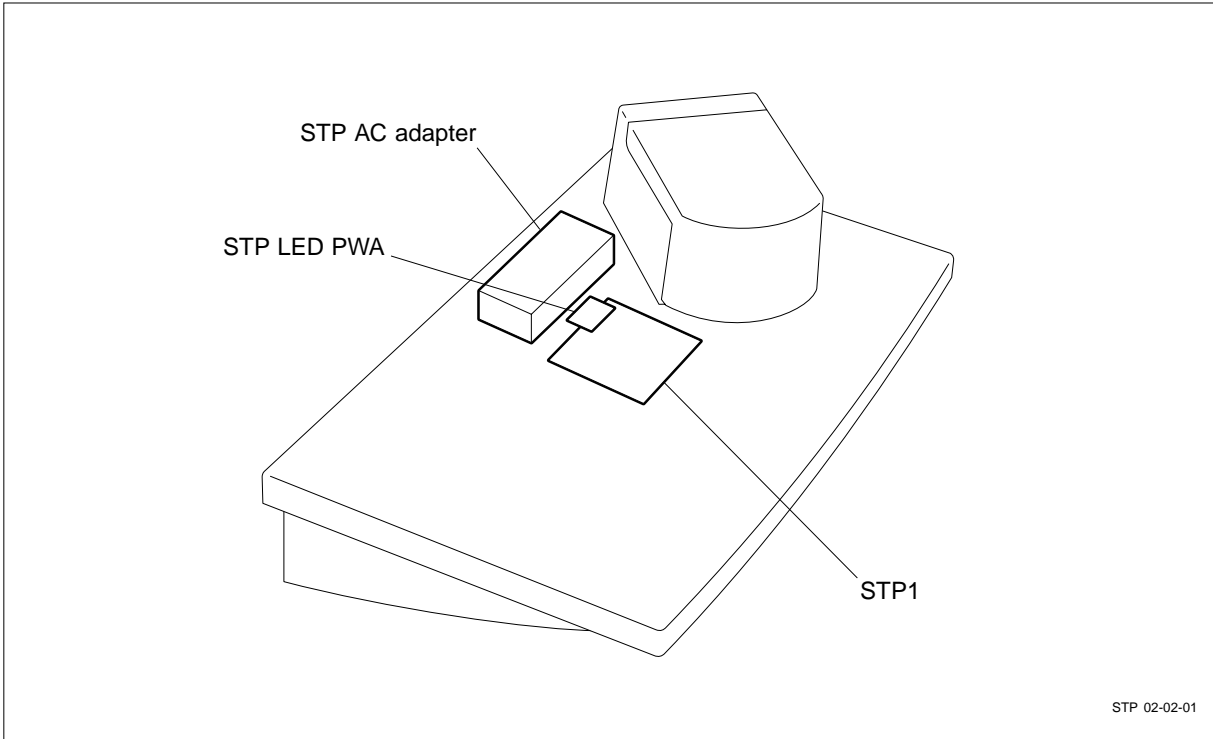

Symbols and functions of various devices

Symbol	Name	Function
SW1	STPCOV-SW STP cover open switch	Detects the open/close state of the cover during staple replacement, etc.
SW2	EMPTY-SW STP staple empty switch	Detects the presence or absence of staples.
SEN1	PSET-SEN STP paper set sensor	Detects the loading of the paper to be stapled.
SEN2	HP-SEN STP home position sensor	Detects the home position of the drive section.
M1	STP motor	Drive the stapler.
STP1	STP CONT PWA	PWA which controls the stapler.
STP2	STP sensor PWA	PWA which relays the sensor signals and motor drive signals.
LED	STP LED PWA	PWA on which the power lamp (LED) is installed.

2.3 Harness Connection Diagram

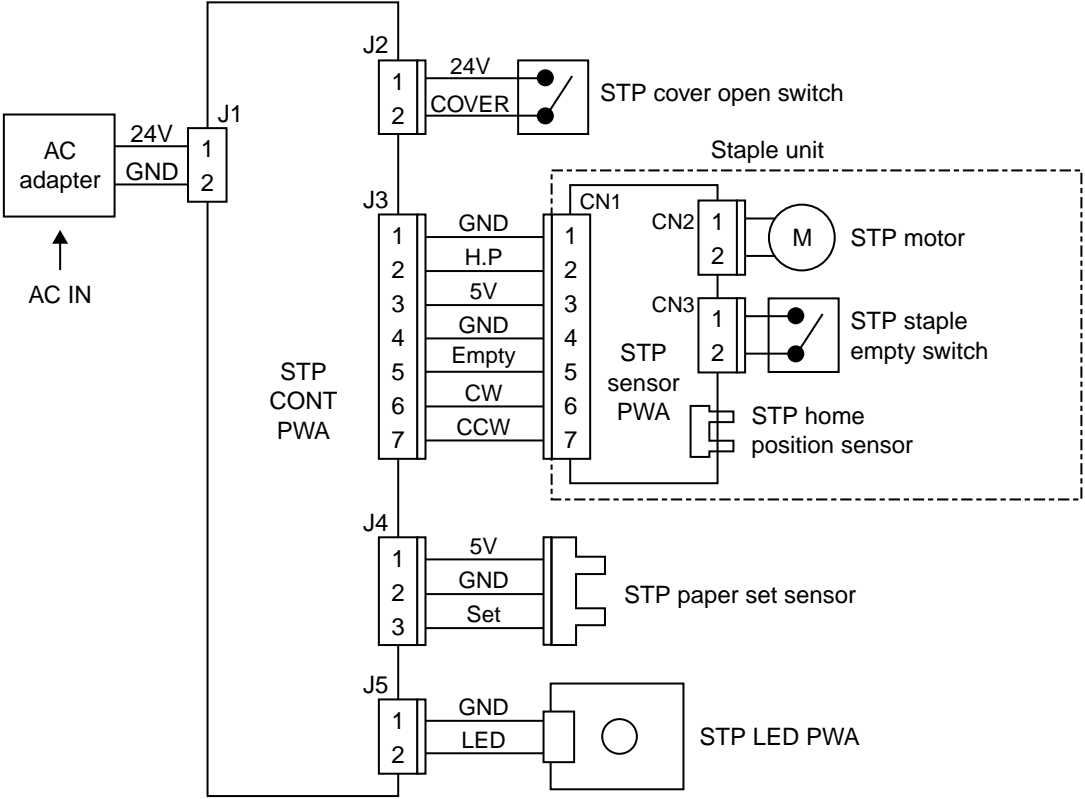

STP 02-03-01

2.4 Board Assembly

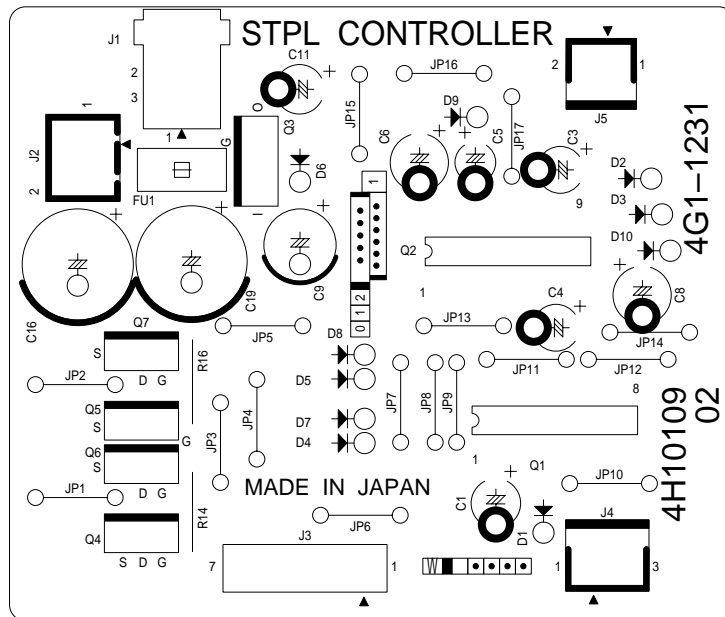

STP 02-04-01

3. OPERATIONAL DESCRIPTION

3.1 General Description

Upon detecting the loading of paper, the STP operates the motor for staple operation. The AC input supplied from the copier is converted to a DC voltage (24V) through the AC adapter in the STP and used as a power supply for the STP.

3.2 Block Diagram

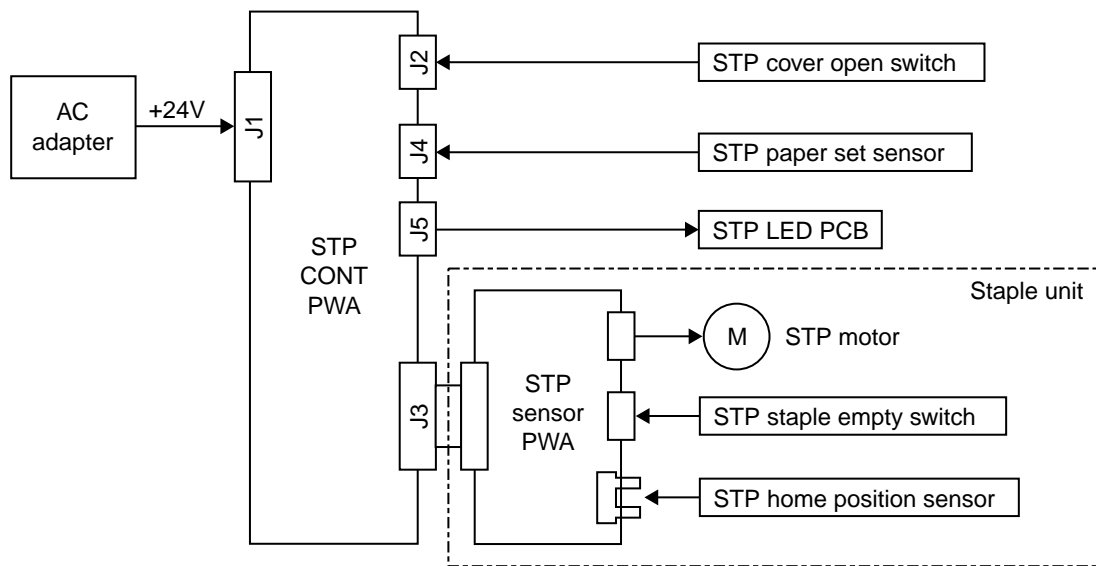

STP 03-02-01

The STP consists of the AC adapter, STP CONT PWA, sensors, power indicator LED, staple unit, etc. The staple unit consists of the STP motor, STP Sensor PWA for relaying the sensor signals, mechanical drive section, etc.

3.3 Detection of Abnormal Status

- **Cover Open/Close Detection**

The STP cover open switch turns OFF when the cover is opened. Since the switch is connected to the power supply, the power supply to the STP is cut when the switch turns OFF. For this reason, all the operation is disabled while the cover is open. When the STP cover is closed, the delivery of the power supply is resumed to light the STP power lamp and enable stapling.

- **Staple Empty Detection**

Upon detecting a staple empty state, the STP staple empty switch resets the motor drive circuit so that the motor does not operate even if the STP paper set sensor detects the presence of paper. This error state is reset when staples are supplied causing the STP paper set sensor to detect the presence of staples.

3.4 Flow Chart

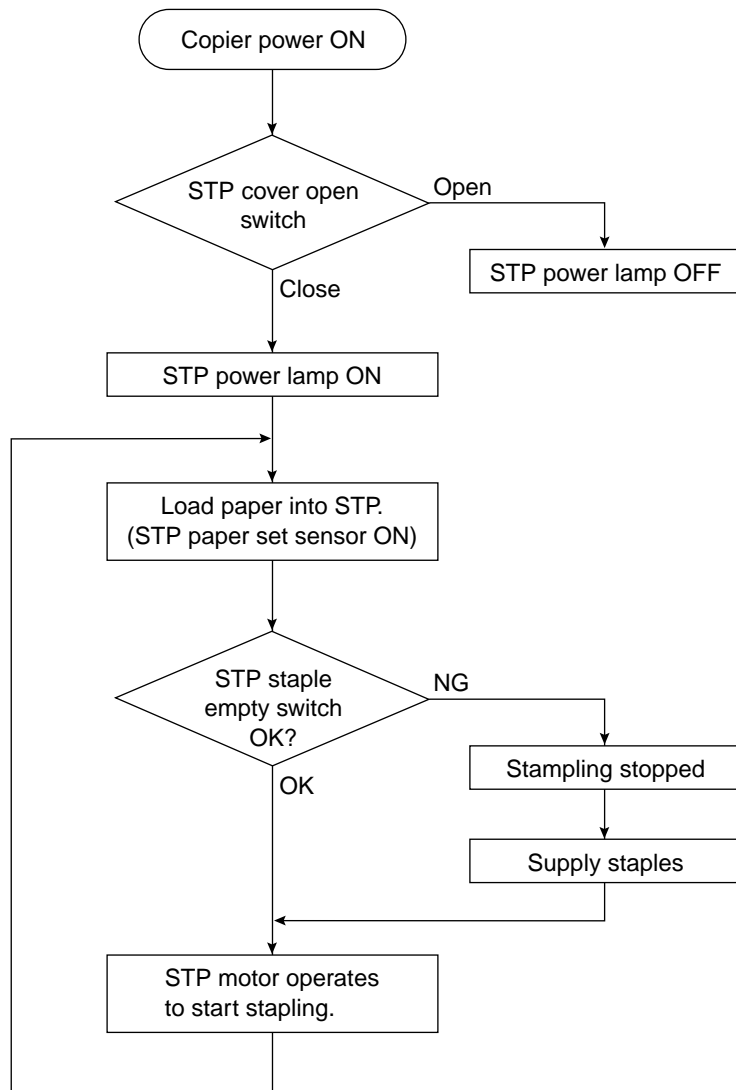

STP 03-04-01

4. MECHANICAL DESCRIPTION

4.1 Mechanism Drawing

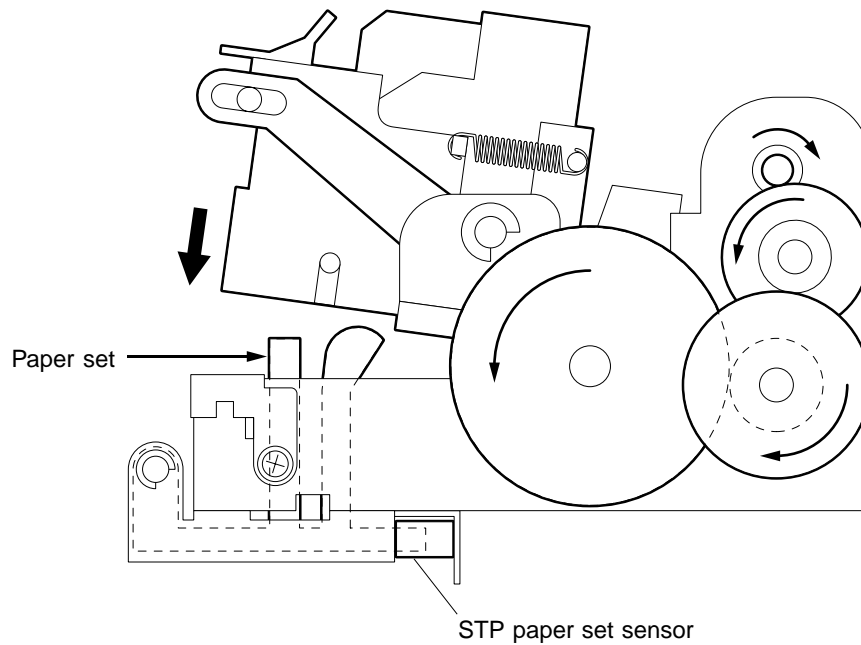

STP 04-01-01

4.2 Staple Operation

The staple operation of the STP is performed only by the rotation of the STP motor through the combination of the gears and cams.

The loading of paper is detected when the paper detection lever is pushed. When paper is loaded into the stapler, the paper detection lever is pushed causing the STP paper set sensor to detect the presence of paper.

When the presence of paper is detected, if staples are available, the STP motor is operated to drive the gears and cams to perform staple operation. If no staples are available, the STP does not operate until staples are supplied. When one time of staple operation is finished, the STP returns to its original state and stands by until the next presence of paper is detected.

Staples are loaded in the cartridge and its capacity is about 5,000 staples. When the cartridge is supplied with staples or a new cartridge is installed, perform staple operation without staples (7 to 8 times) to feed staples to a position where stapling is possible.

5. CIRCUIT DESCRIPTION

5.1 PWA Block Diagram

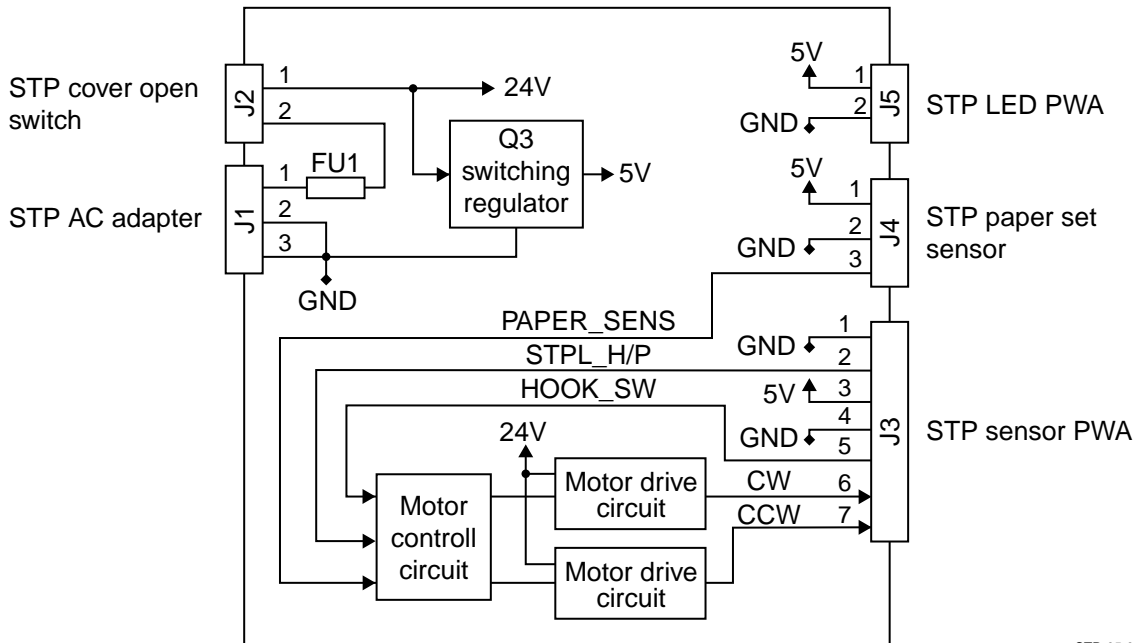

STP 05-01-01

5.2 Functional Description

The STP operates the stapler through the STP controller PWA. When the power of the copier is turned on, a power supply is also delivered to the STP to enable stapling. When paper is loaded into the stapler, the STP paper set sensor detects the presence of paper (changing from "High" to "Low"), and 200 ms later the CW signal turns ON (changing from "Low" to "High") to operate the STP motor forward. When the motor operates, the gears and cams of the stapler operate for stapling. When the STP home position sensor detects the home position of the stapler (changing from "High" to "Low") after the CW signal is activated, the CW signal turns OFF.

If the STP home position sensor remains at "High" level (a failure to return to the home position) for some reason even if a fixed time (approx. 900 ms) has elapsed after the CW signal turns ON, the CW signal turns OFF and 100 ms later the CCW signal is turned ON (changing from "Low" to "High") to operate the STP motor reversely. In practice, however, if the STP has locked up mechanically, an overload occurs so that the fuse installed on the STP CONT PWA will blow or the protective circuit of the AC adapter will function to cut the delivery of the power supply (shutdown).

If the stapler is not at the home position when the power is turned on ("High" level), about 60 ms later the CCW signal is turned ON (changing from "Low" to "High") to operate the motor reversely allowing the stapler to return to the home position.

5.3 Signal Description

Signal Name	Part Name	Functional Description	Status	Note
STPCOV	STP cover open switch	Detects the open/close state of the cover during staple replacement, etc.	Open: Power off	Microswitch
STPPSET	STP paper set sensor	Detects the loading of the paper to be stapled.	Low: Paper loaded	Photo sensor
STPHP	STP home position sensor	Detects the home position of the drive section.	Low: Home position	Photo sensor
STPEMP	STP staple empty switch	Detects the presence or absence of staples.	Low: No staples	Microswitch

The STP cover open switch detects the open or close state of the cover. A microswitch is used for the switch. A power supply is delivered to the stapler when the cover is closed, and cut off when open.

The STP paper set sensor detects the loading of paper. A photo sensor is used for the switch. The signal goes LOW when the paper to be stapled is loaded.

The STP home position sensor detects the home position of the stapler. A photo sensor is used for the sensor. It is mounted on the STP sensor PWA and detects the home position every stapling.

The STP staple empty switch detects the presence or absence of staples. A microswitch is used for the sensor. When staples have run out or no cartridge is mounted, the signal is detected at "Low" level.

5.4 Timing Charts

- Staple operation

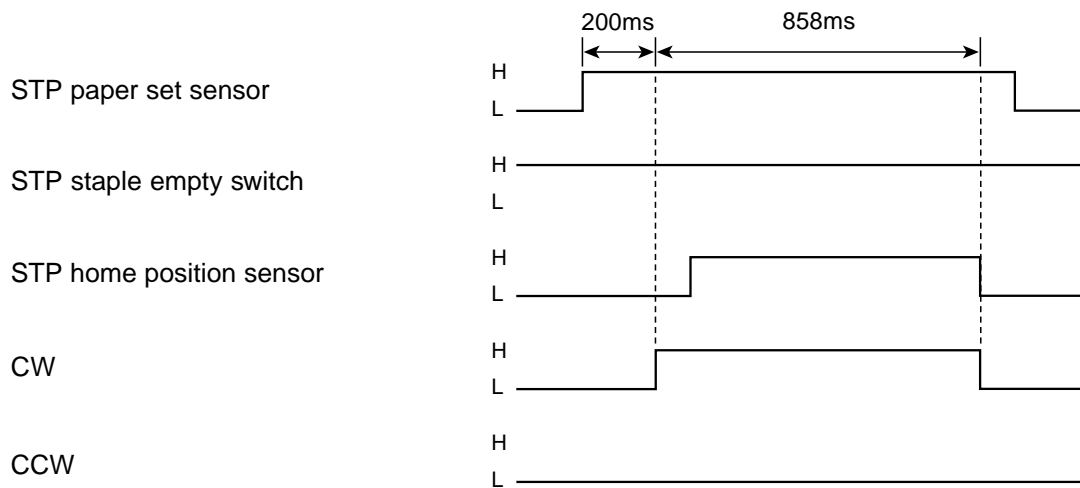

- Staple operation (When staples have run out during operation)

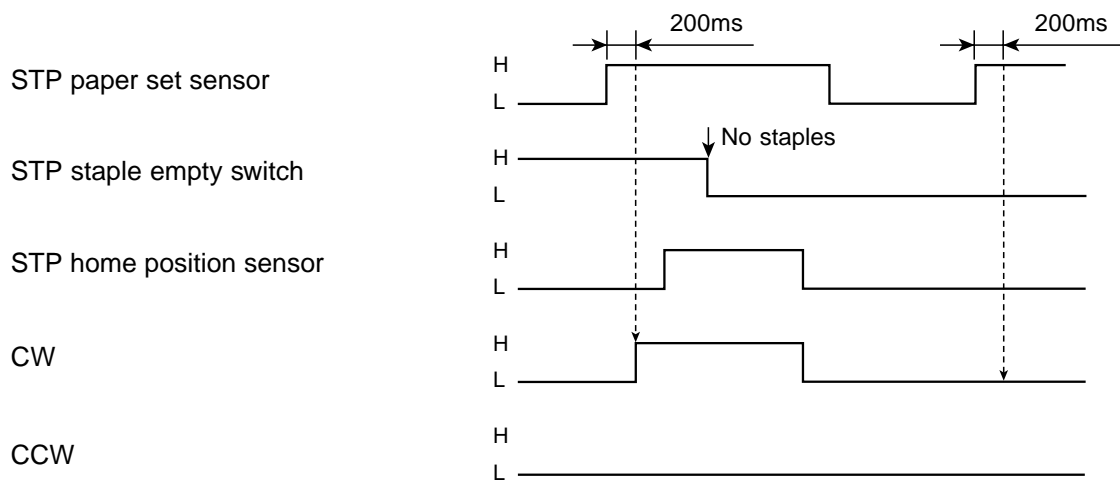

- Reverse operation (When the motor has locked up)

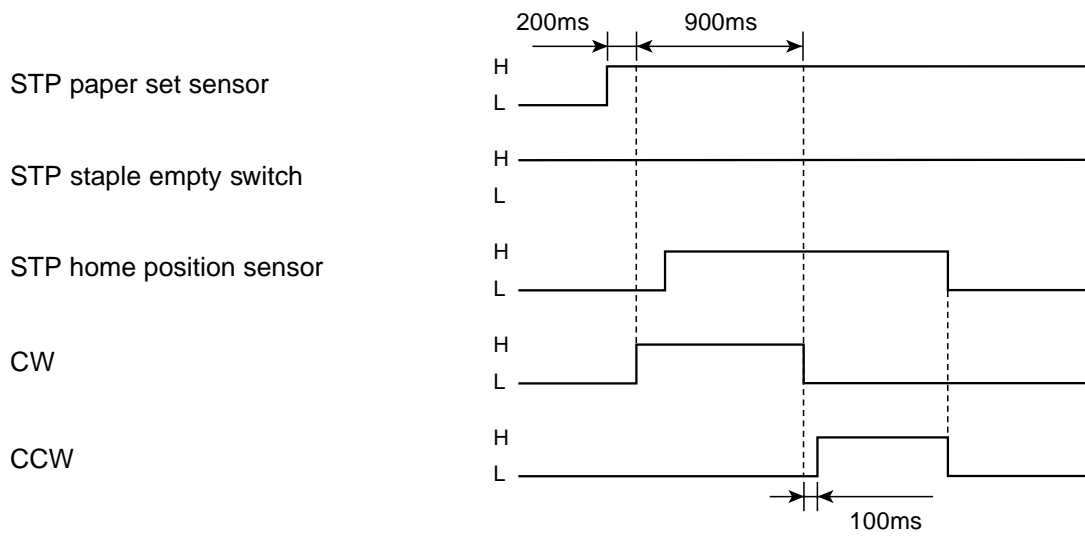

- Reverse operation (When the stapler is not at the home position at power on time)

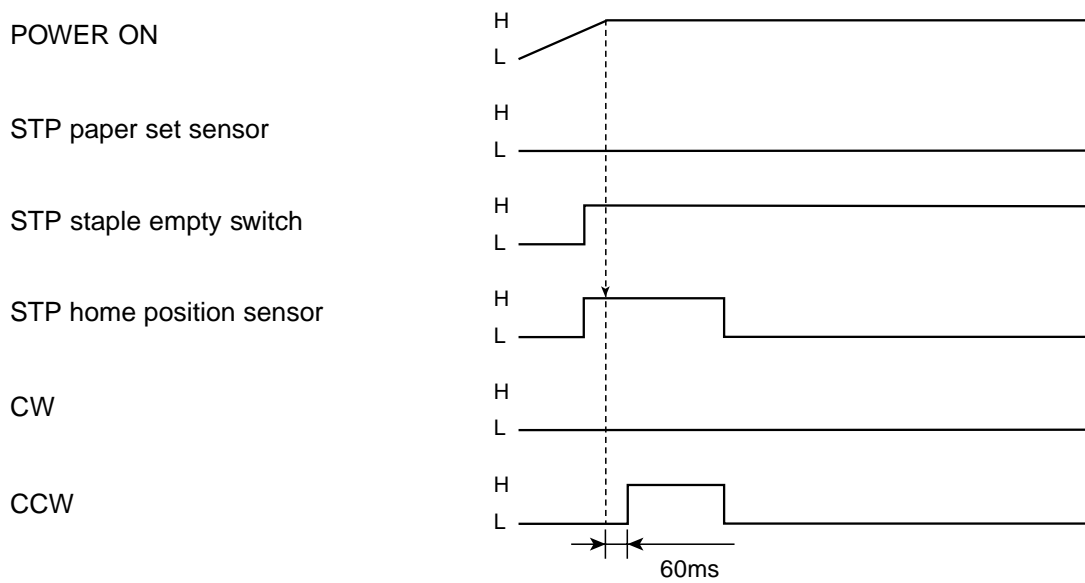

6. DISASSEMBLY AND REPLACEMENT

[A] STP cover/STP staple cartridge

1. Pull STP cover to release one hook and open STP cover.

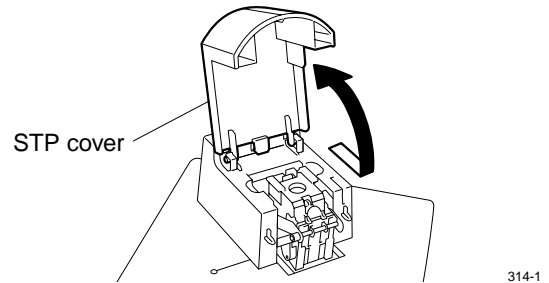

Fig. 6-1

2. Release 2 hooks and detach STP cover.

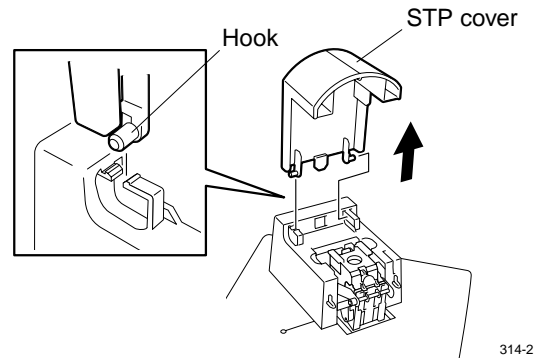

Fig. 6-2

3. Release 2 hooks and remove STP staple cartridge.

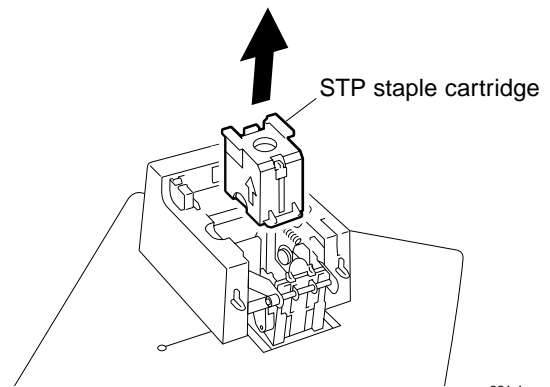

Fig. 6-3

[B] STP bottom cover F

1. Remove one screw and detach connector cover.

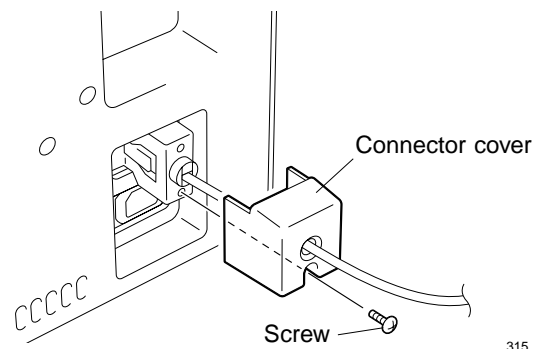

Fig. 6-4

2. Remove 2 screws and remove connector plate.
3. Release 2 hooks and detach connector.

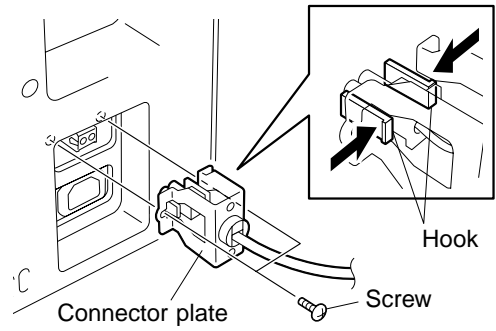

Fig. 6-5

316-1

4. Release the power cable from the hook of the manual pocket.

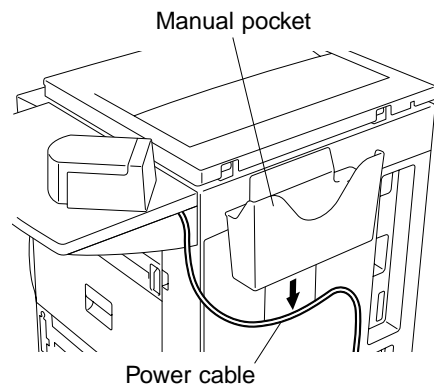

Fig. 6-6

316-2

5. Remove 2 screws, release 2 hooks, and remove stapler.

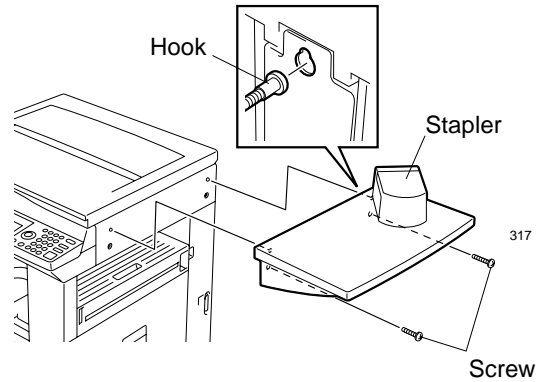

Fig. 6-7

317

6. Remove one screw and detach STP bottom cover F.

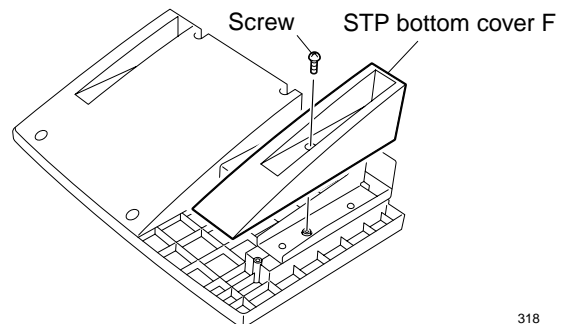

Fig. 6-8

318

[C] STP bottom cover R

1. Remove stapler. (See Fig. 6-4 to 6-7)
2. Remove 4 screws and detach STP bottom cover R.

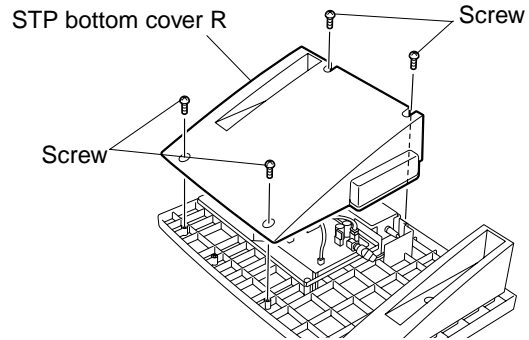

Fig. 6-9

[D] STP staple cover

1. Detach STP cover. (See Fig. 6-1 and 6-2)
2. Remove STP staple cartridge. (See Fig. 6-3)
3. Remove stapler. (See Fig. 6-4 to 6-7)
4. Detach STP bottom cover R. (See Fig. 6-9)
5. Remove one screw, release 5 hooks, and detach STP staple cover.

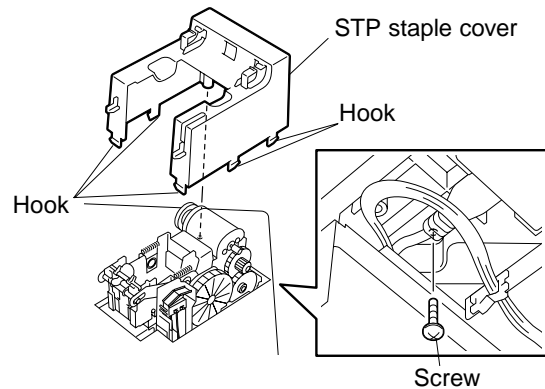

Fig. 6-10

[E] STP cover open switch

1. Detach STP cover. (See Fig. 6-1 and 6-2)
2. Remove STP staple cartridge. (See Fig. 6-3)
3. Remove stapler. (See Fig. 6-4 to 6-7)
4. Detach STP bottom cover. (See Fig. 6-9)
5. Detach STP staple cover. (See Fig. 6-10)
6. Detach one connector from STP controller PWA (J2) and release 3 clamps.
7. Remove one screw and remove STP cover open switch.

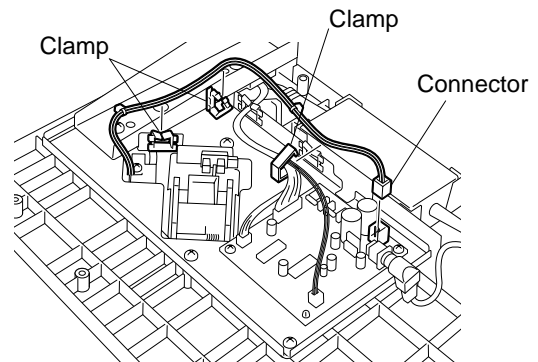

Fig. 6-11

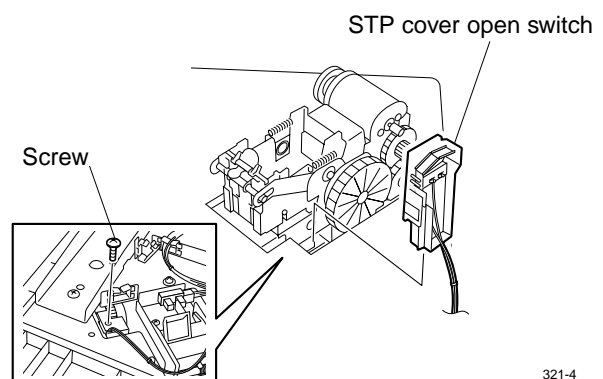

Fig. 6-12

[F] AC adapter

1. Remove stapler. (See Fig. 6-4 to 6-7)
2. Detach STP bottom cover R. (See Fig. 6-9)
3. Detach AC adapter jack from STP controller PWA (J1).
4. Detach power cord and remove AC adapter.

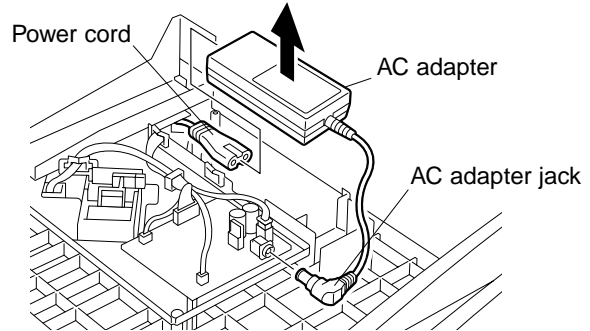

Fig. 6-13

[G] STP LED PWA

1. Remove stapler. (See Fig. 6-4 to 6-7)
2. Detach STP bottom cover R. (See Fig. 6-9)
3. Remove AC adapter. (See Fig. 6-13)
4. Detach one connector from STP controller PWA (J5) and release 2 clamps.

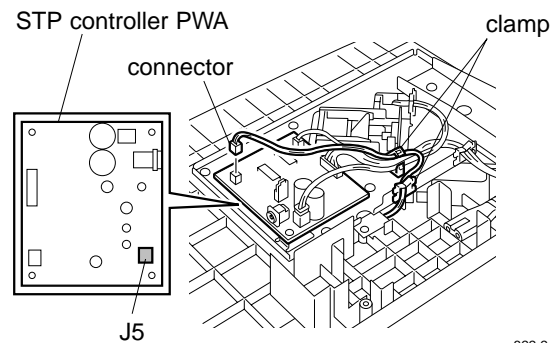

Fig. 6-14

5. Remove one screw and remove STP LED PWA.

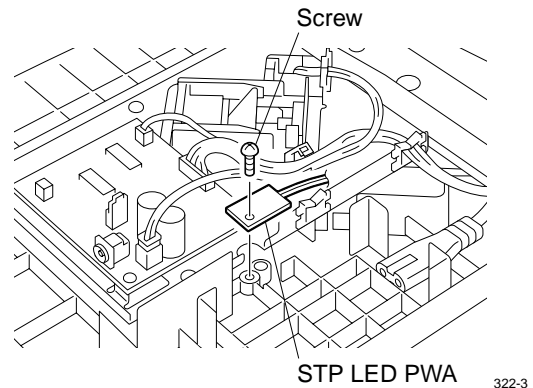

Fig. 6-15

[H] STP base stay assembly

1. Remove stapler. (See Fig. 6-4 to 6-7)
2. Detach STP bottom cover R. (See Fig. 6-9)
3. Detach AC adapter jack and the connectors from STP controller PWA (J1/J2/J5).
4. Release 4 clamps.

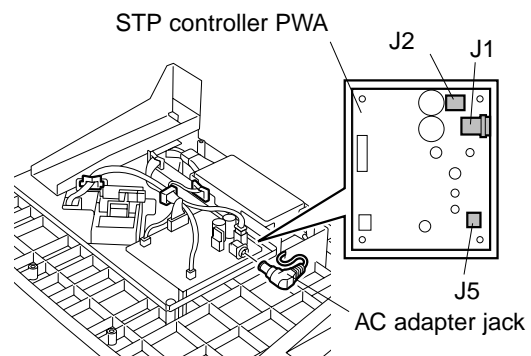
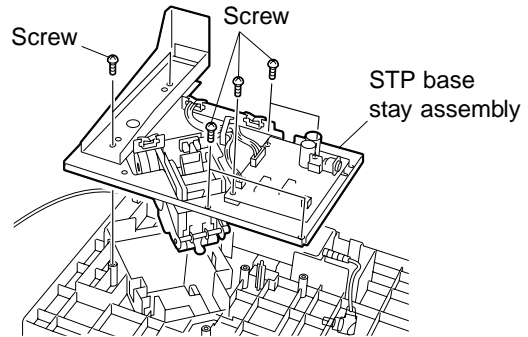

Fig. 6-16

- Remove 7 screws and remove STP base stay assembly.



324

Fig. 6-17

[I] STP base

- Detach STP cover. (See Fig. 6-1 and 6-2)
- Remove STP staple cartridge. (See Fig. 6-3)
- Remove stapler. (See Fig. 6-4 to 6-7)
- Detach STP bottom cover F. (See Fig. 6-8)
- Detach STP bottom cover R. (See Fig. 6-9)
- Detach STP staple cover. (See Fig. 6-10)
- Remove STP cover open switch. (See Fig. 6-11 and 6-12)
- Remove AC adapter. (See Fig. 6-13)
- Remove STP LED PWA. (See Fig. 6-14 and 6-15)
- Remove STP base stay assembly. (See Fig. 6-16 and 6-17)
- Remove 2 screws and remove STP stay.

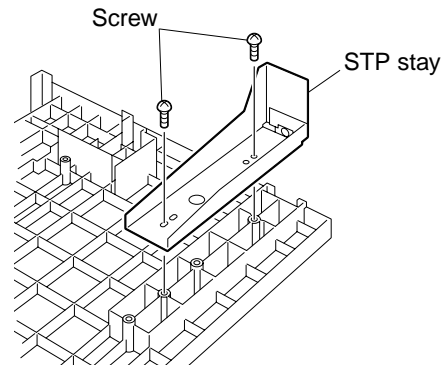

325

Fig. 6-18

[J] STP controller PWA

- Remove stapler. (See FIG. 6-4 to 6-7)
- Detach STP bottom cover R. (See FIG. 6-9)
- Detach AC adapter jack and all connectors from STP controller PWA.
- Remove 2 screws and remove STP controller PWA.

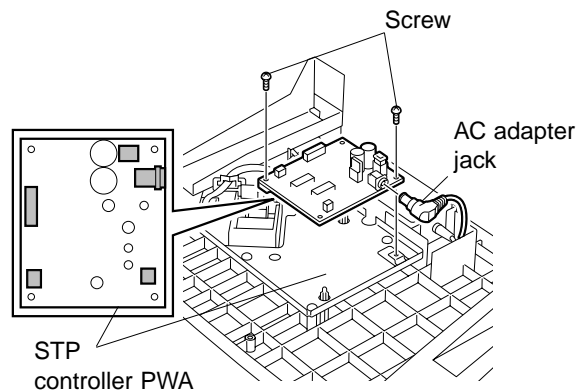

326

Fig. 6-19

[K] STP staple unit

1. Remove stapler. (See Fig. 6-4 to 6-7)
2. Detach STP bottom cover R. (See Fig. 6-9)
3. Remove STP base stay assembly. (See Fig. 6-16 and 6-17)
4. Detach the connectors from STP controller PWA (J3/J4) and release 2 clamps.

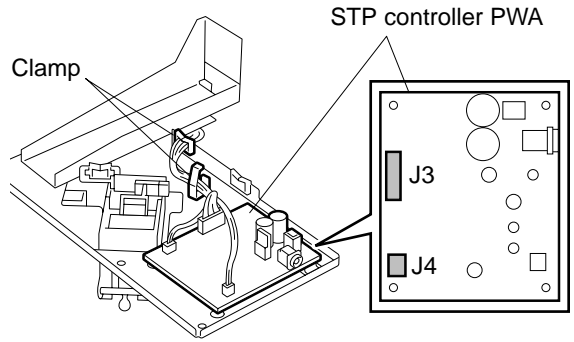

Fig. 6-20

5. Remove 2 screws and remove STP staple unit.

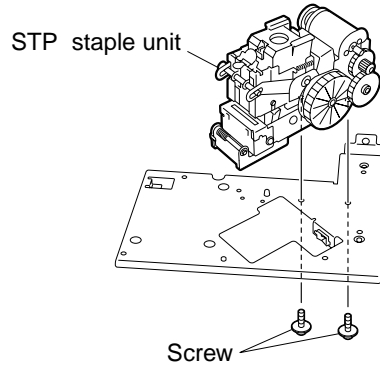

Fig. 6-21

Free Manuals Download Website

<http://myh66.com>

<http://usermanuals.us>

<http://www.somanuals.com>

<http://www.4manuals.cc>

<http://www.manual-lib.com>

<http://www.404manual.com>

<http://www.luxmanual.com>

<http://aubethermostatmanual.com>

Golf course search by state

<http://golfingnear.com>

Email search by domain

<http://emailbydomain.com>

Auto manuals search

<http://auto.somanuals.com>

TV manuals search

<http://tv.somanuals.com>