

## CHAPTER 2

### INSTALLATION

#### 2.1 INSTALLATION ENVIRONMENT

Table 2.1 shows the environmental conditions for the location in which the SR-HSP Series Robot and SR7000 Controller are to be installed.

Table 2.1 Environmental Conditions for the Robot and Controller

Item	Specifications
Temperature	In operation : 0 to 40 °C In storage : -10 to 50 °C
Humidity	20 to 90 % (Non-condensing) Do not install the robot where it may be subject to fluids such as water.
Altitude	1000 m or less
Vibration	In operation : Within 0.98m/s <sup>2</sup> In transport : Within 9.8m/s <sup>2</sup>
Dust	There is to be no inductive dust. Please consult with Toshiba first should you wish to use the robot and controller in an especially dusty environment.
Gas	There is to be no corrosive or combustible gas.
Sunlight	The robot must not be subject to direct sunlight.
Electromagnetic noise	There are to be no devices in the area which produce an excessive amount of electromechanical noise.
Field	There are to be no devices in the area that generate a strong field.



#### Danger

- Do not place the robot near combustible matters.  
Doing so could lead to fires if the matter ignites due to a fault, etc.

#### 2.2 ROBOT INSTALLATION

Before actually installing the robot, you must plan a layout and take into consideration such matters as the working space, coordinate system and space for maintenance.

##### 2.2.1 External Dimensions

An outline drawing of the robot is shown in Figs. 2.1 to 2.5.

Fig. 2.1 External view of SR-504HSP robot

Fig. 2.2 External view of SR-554HSP robot

Fig. 2.3 External view of SR-654HSP robot

Fig. 2.4 External view of SR-854HSP robot

Fig. 2.5 External view of SR-1054HSP robot

## 2.2.2 Working Space

Figs. 2.6 to 2.10 show the working space of the robot. Each axis can operate within the working space. To keep the robot from moving out of the working space by mis-operation, the robot is equipped with mechanical stoppers outside the moving range. In addition, soft limits are provided which may be set as desired by the user.

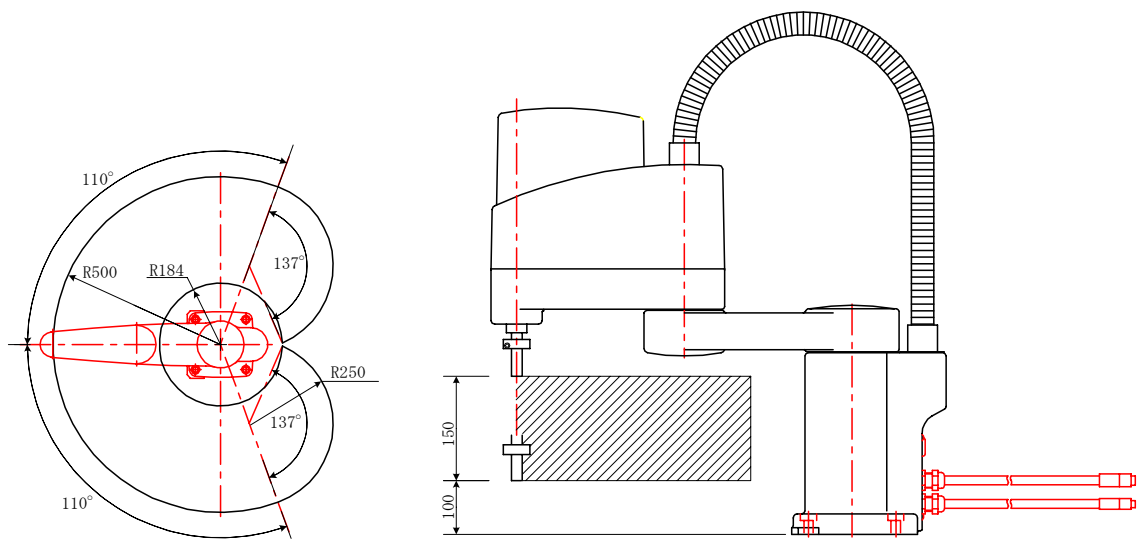

Fig. 2.6 SR-504HSP robot working space

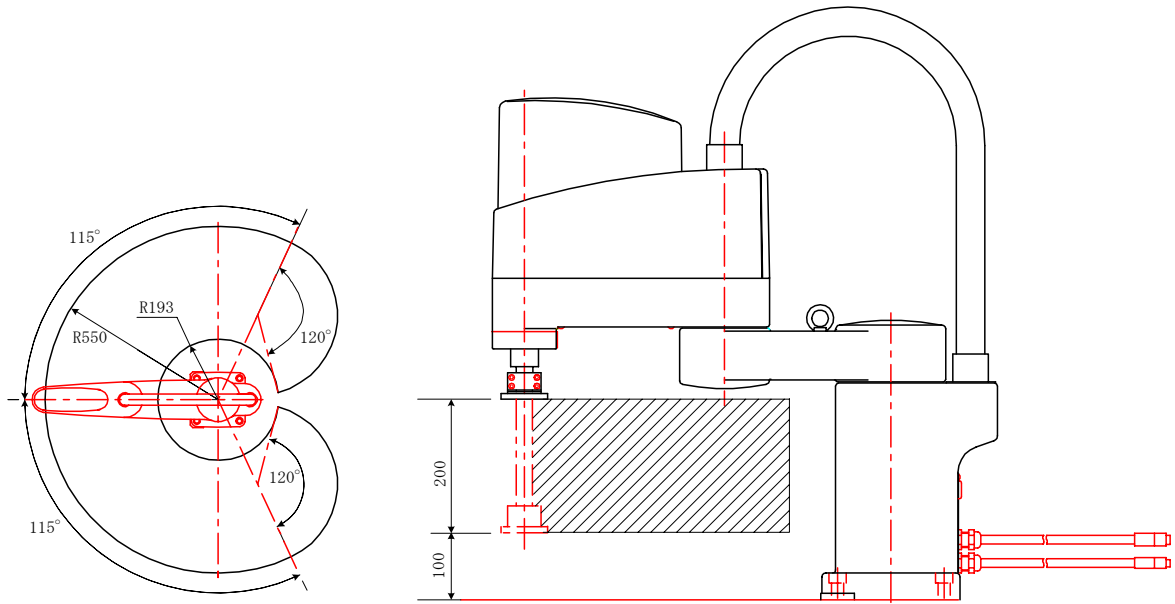

Fig. 2.7 SR-554HSP robot working space

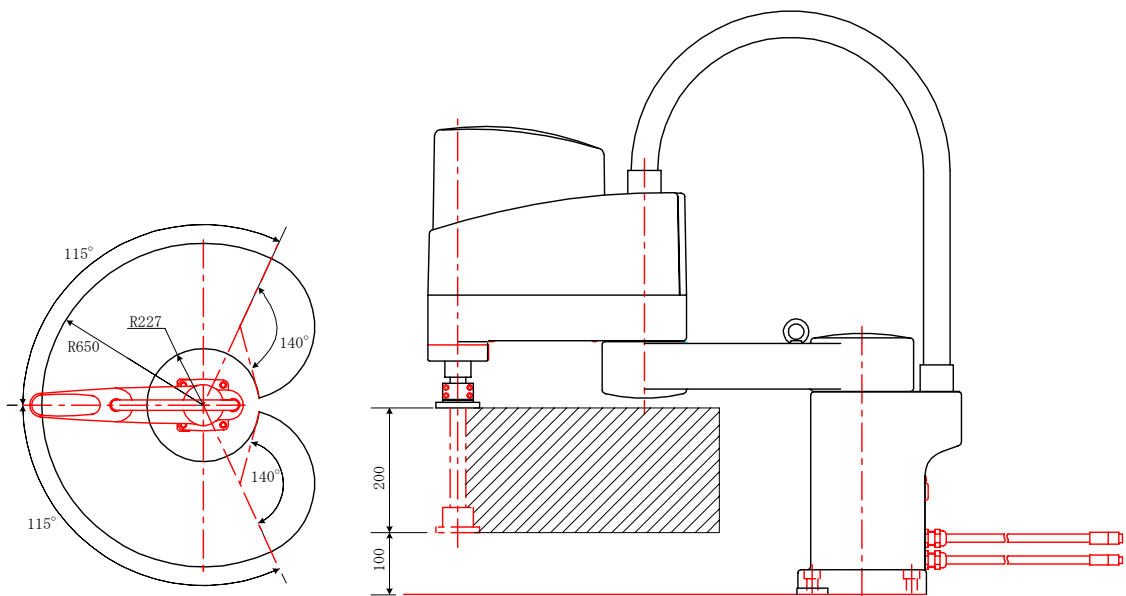

Fig. 2.8 SR-654HSP robot working space



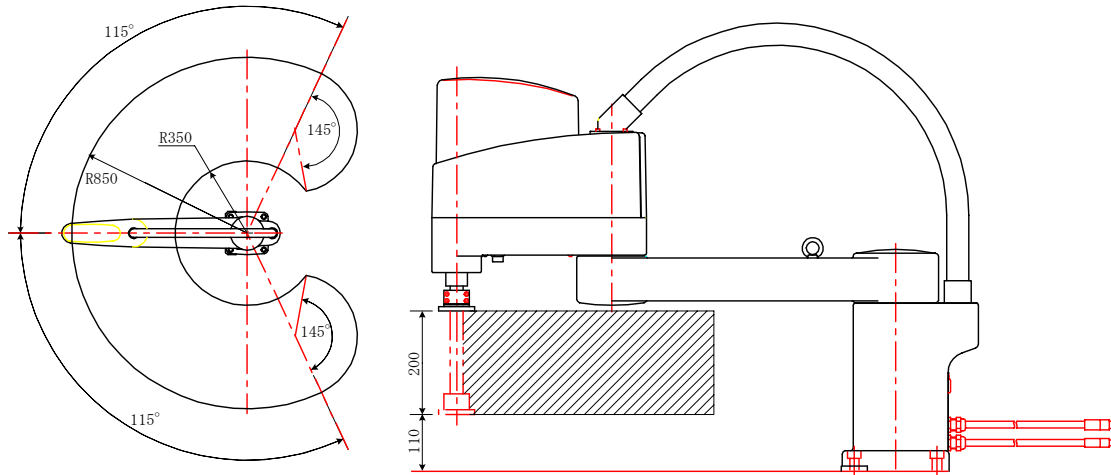

Fig. 2.9 SR-854HSP robot working space

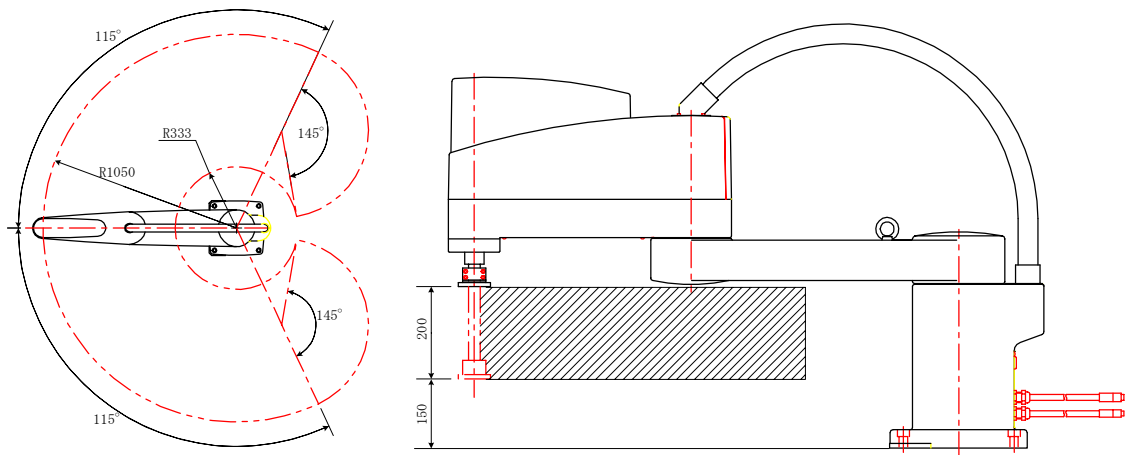

Fig. 2.10 SR-1054HSP working space

### 2.2.3 Coordinate System

The robot's joint angle zero point ( $0^\circ$  or 0mm position) has been calibrated before shipment in respect to the base reference planes. The base coordinate system will be determined according to this calibration. Figs. 2.11 to 2.15 show the base coordinate system and the zero positions of each axis joint angle.

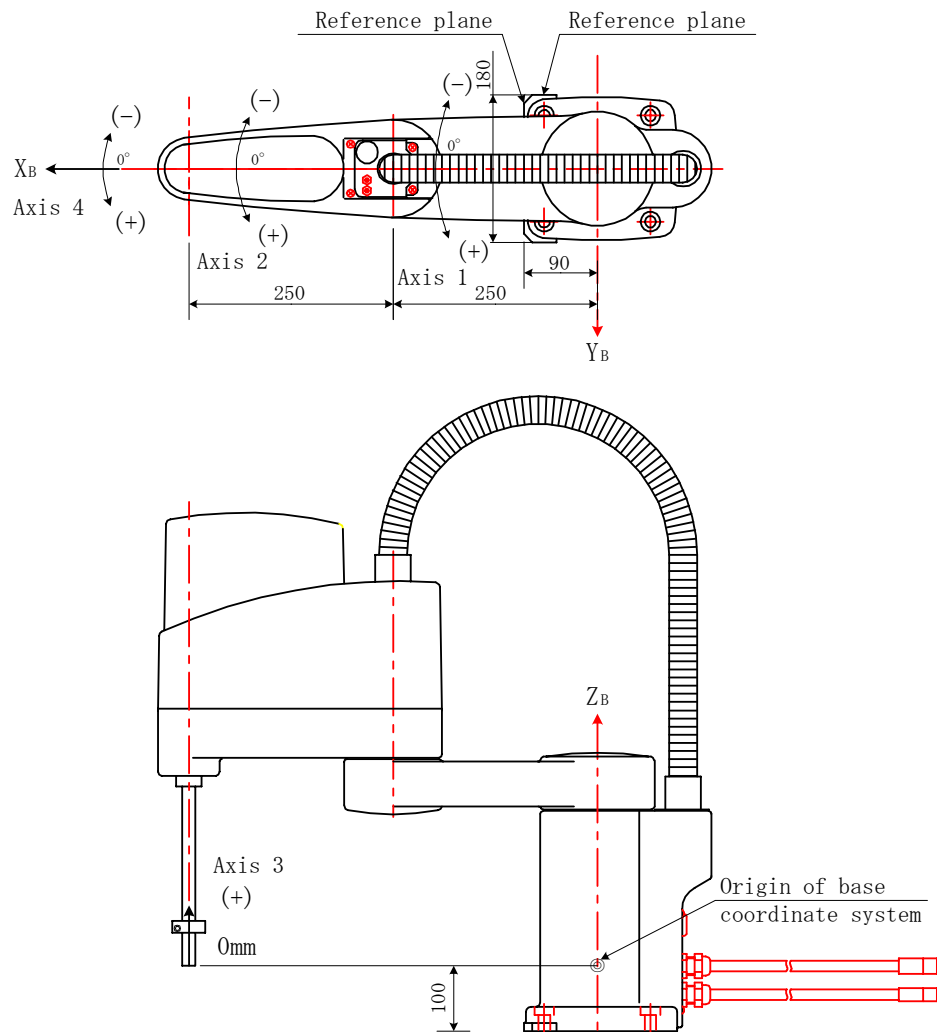

Fig. 2.11 SR-504HSP base coordinate system and joint angle zero point

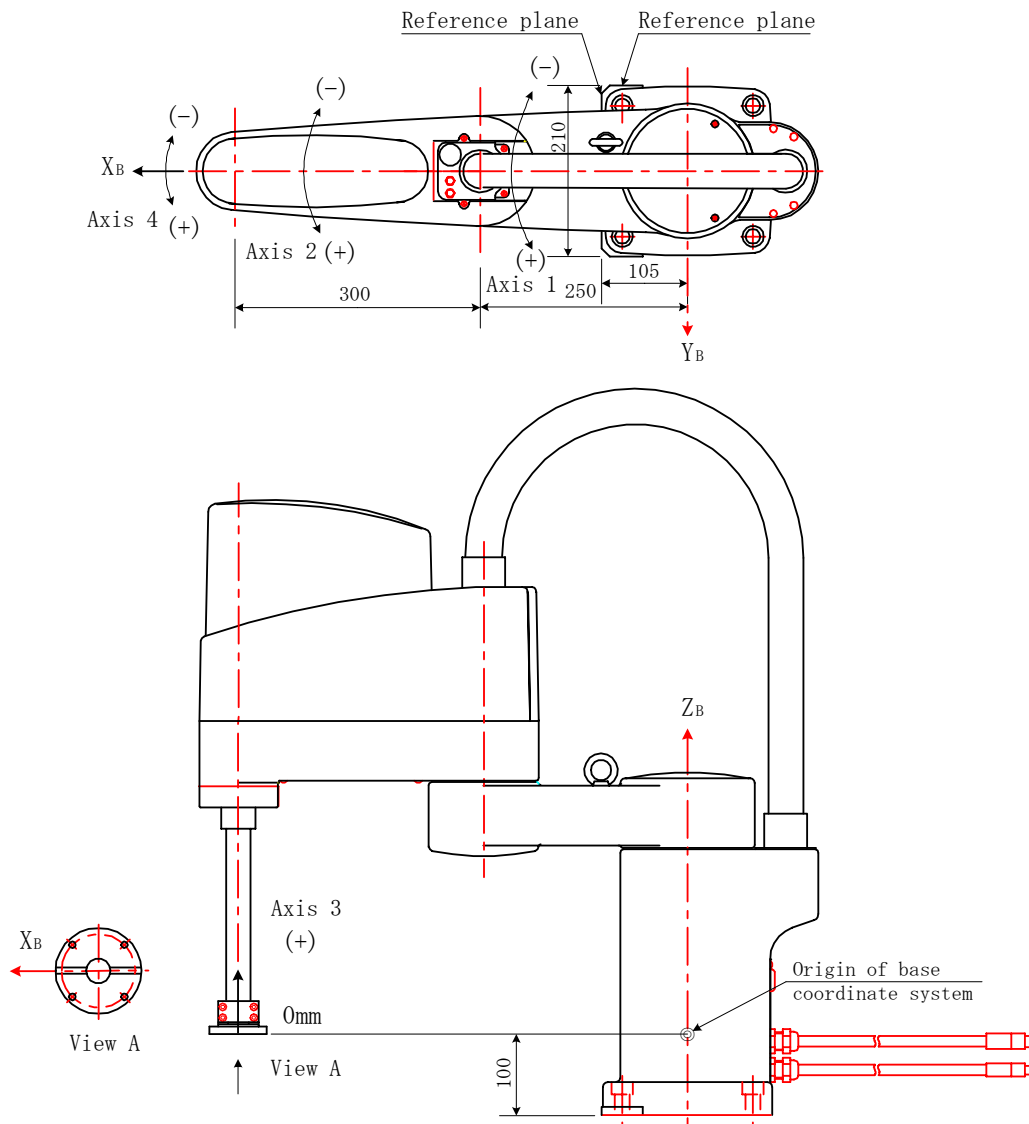

Fig. 2.12 SR-554HSP base coordinate system and joint angle zero point

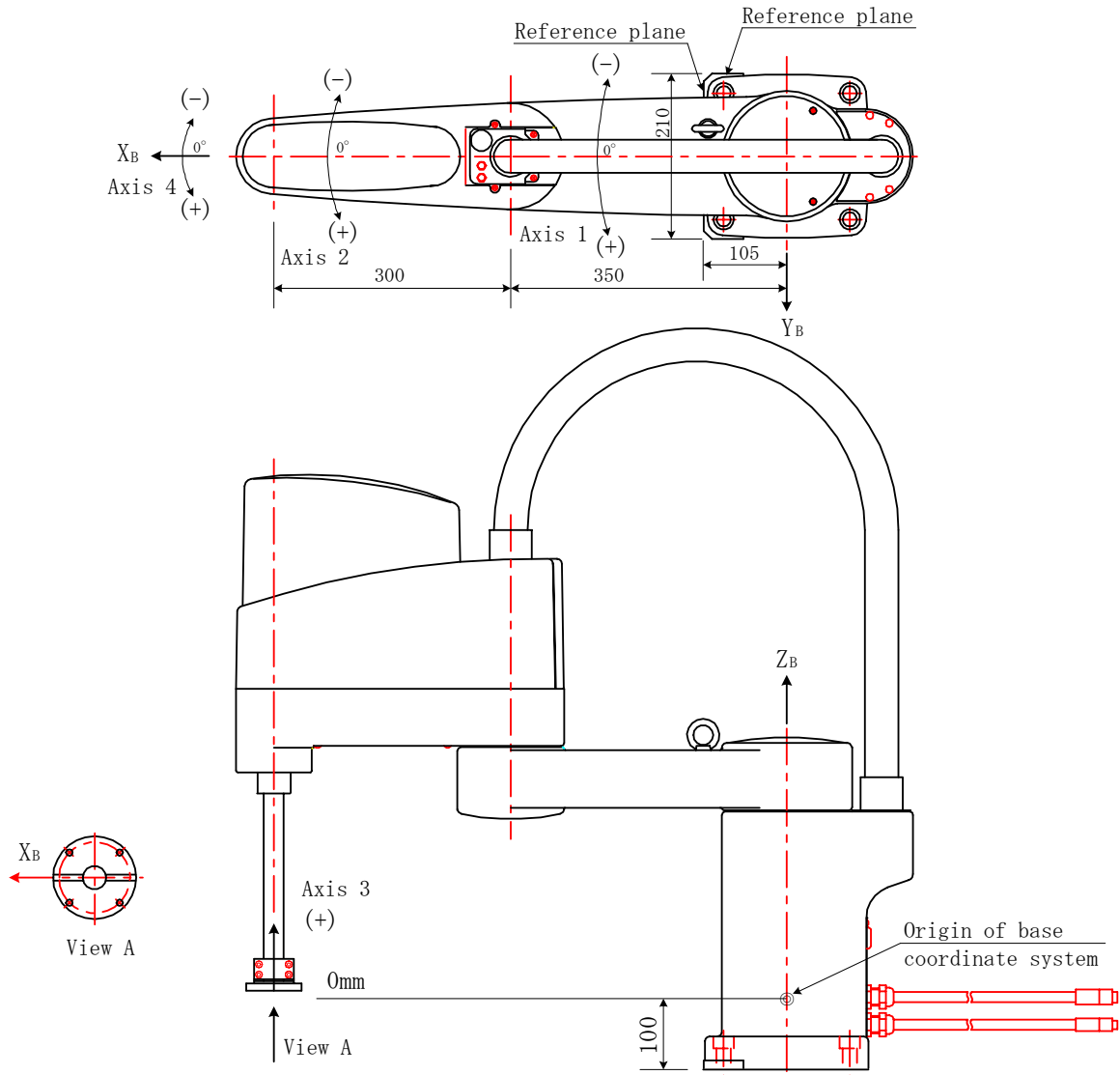

Fig. 2.13 SR-654HSP base coordinate system and joint angle zero point

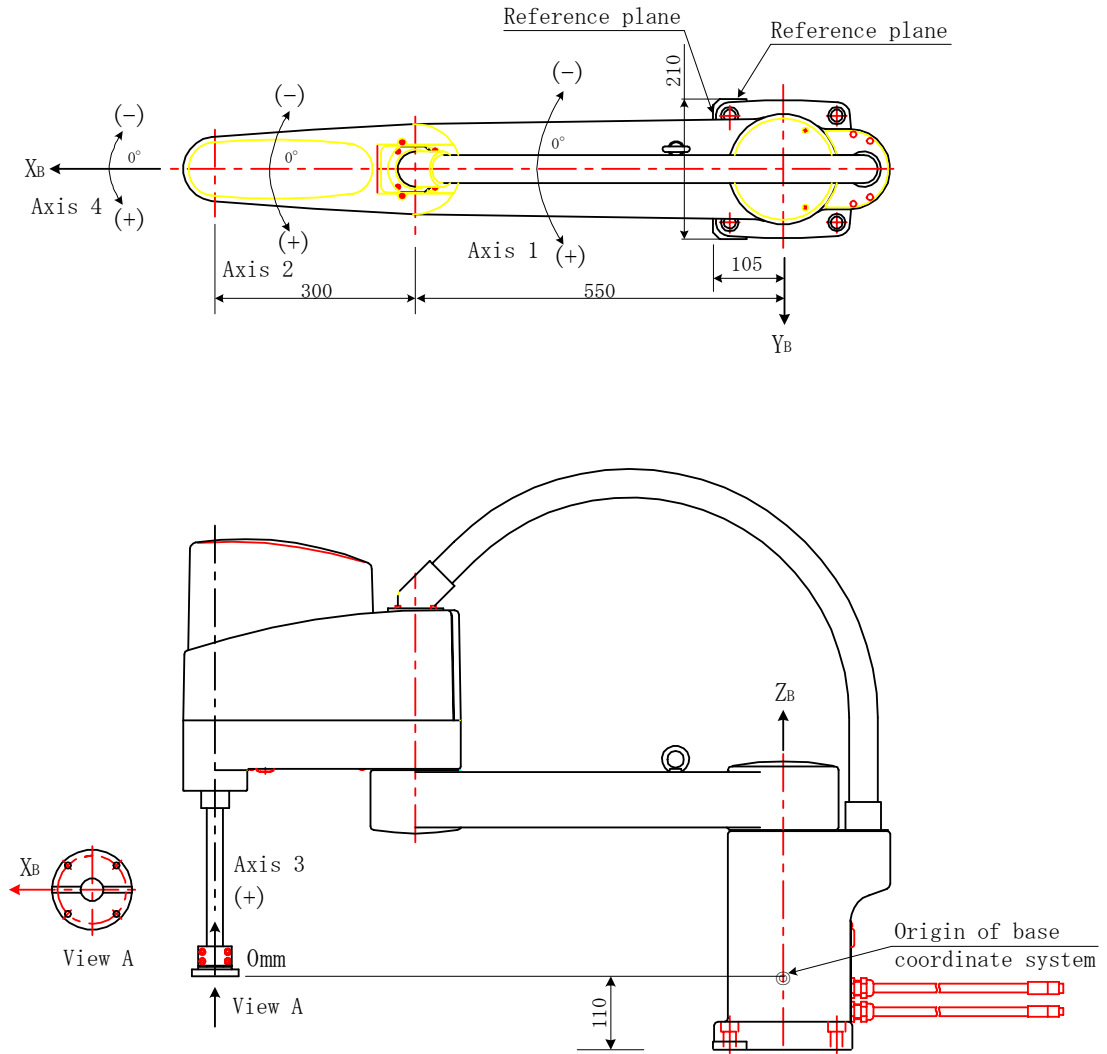

Fig. 2.14 SR-854HSP base coordinate system and joint angle zero point

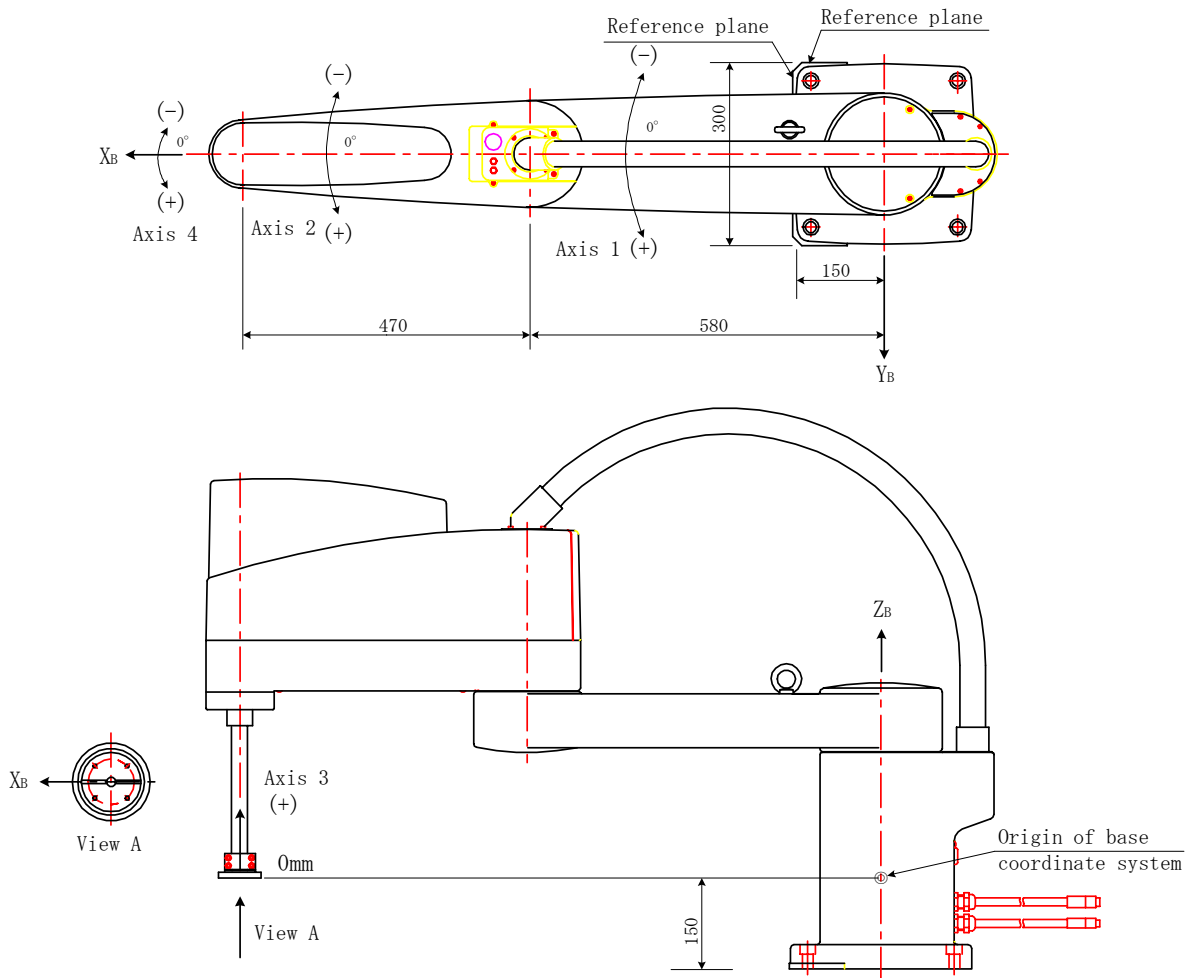

Fig. 2.15 SR-1054HSP base coordinate system and joint angle zero point

## 2.2.4 Installing the Robot

The robot is fastened down using the mounting holes in the base.

Use M12 hexagon socket bolts for the SR-504HSP and M16 hexagon socket bolts for the SR-554HSP, SR-654HSP, SR-854HSP and SR-1054HSP.

The robot installation method is shown in Figs. 2.16 to 2.18. A reference plane is prepared on the base section and is marked with "xxx".

To align the robot's base coordinate system position or when the robot must be replaced, prepare an adequate reference plane. Then, contact that reference plane to the base reference plane and fasten. The reference plane has been coated with anticorrosive agents before shipment, so wipe the agent off with thinner before using.



### Caution

- The robot will suddenly accelerate and decelerate during operation, so when installing it on a frame, make sure that the frame has sufficient strength and rigidity. If the robot is installed on a frame that does not have sufficient rigidity, the vibration will occur while the robot is operating, and could lead to faults. When installing the robot on the floor, fasten the robot down securely with foundation bolts.
- Install the robot on a level place. Failure to do so could lead to a drop in performance or faults.

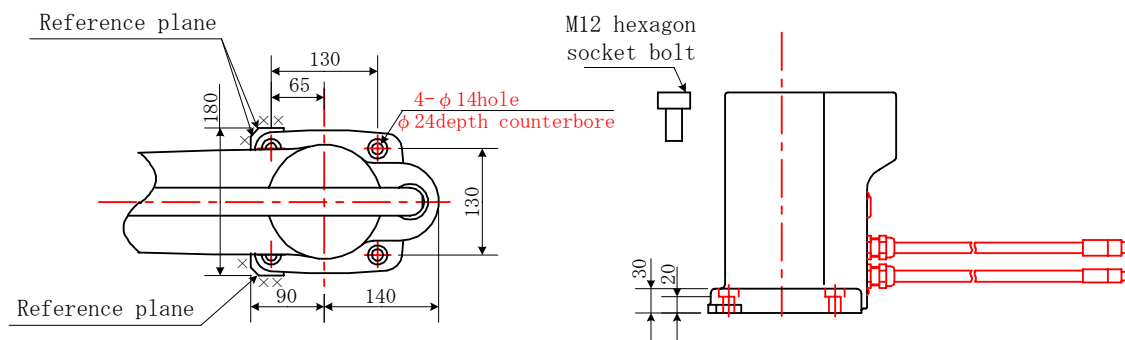

Fig. 2.16 Installing the SR-504HSP robot

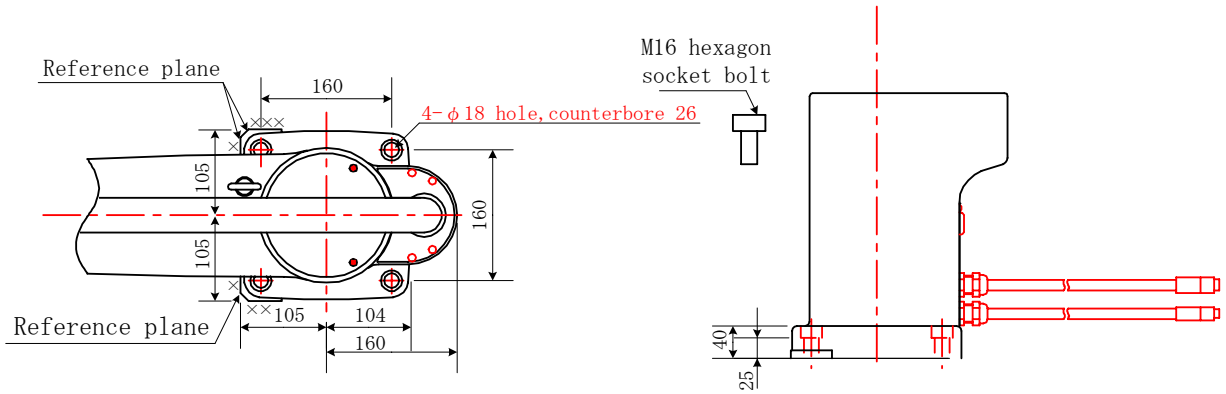

Fig. 2.17 Installing the SR-554HSP,SR-654HSP, SR-854HSP robot

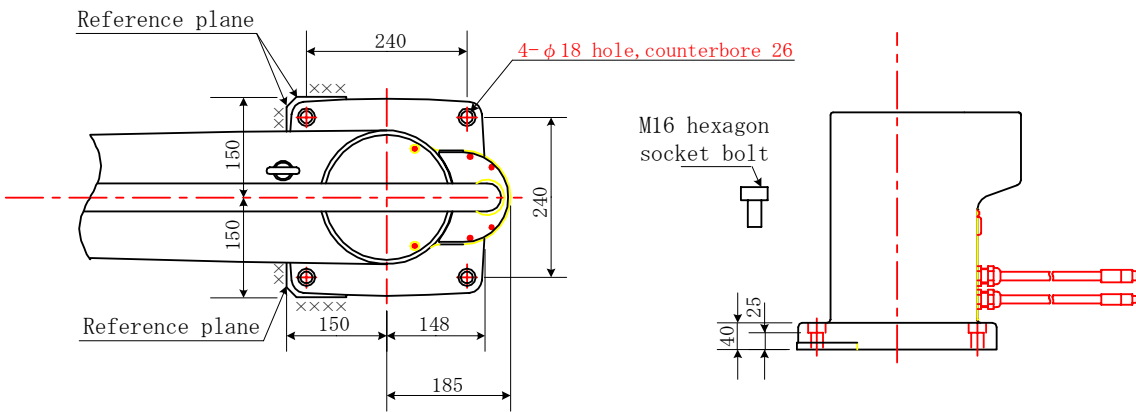

Fig. 2.18 Installing the SR-1054HSP robot



## 2.3 INSTALLING THE CONTROLLER

### 2.3.1 External Dimensions

An external view of the controller is shown in Fig 2.19.

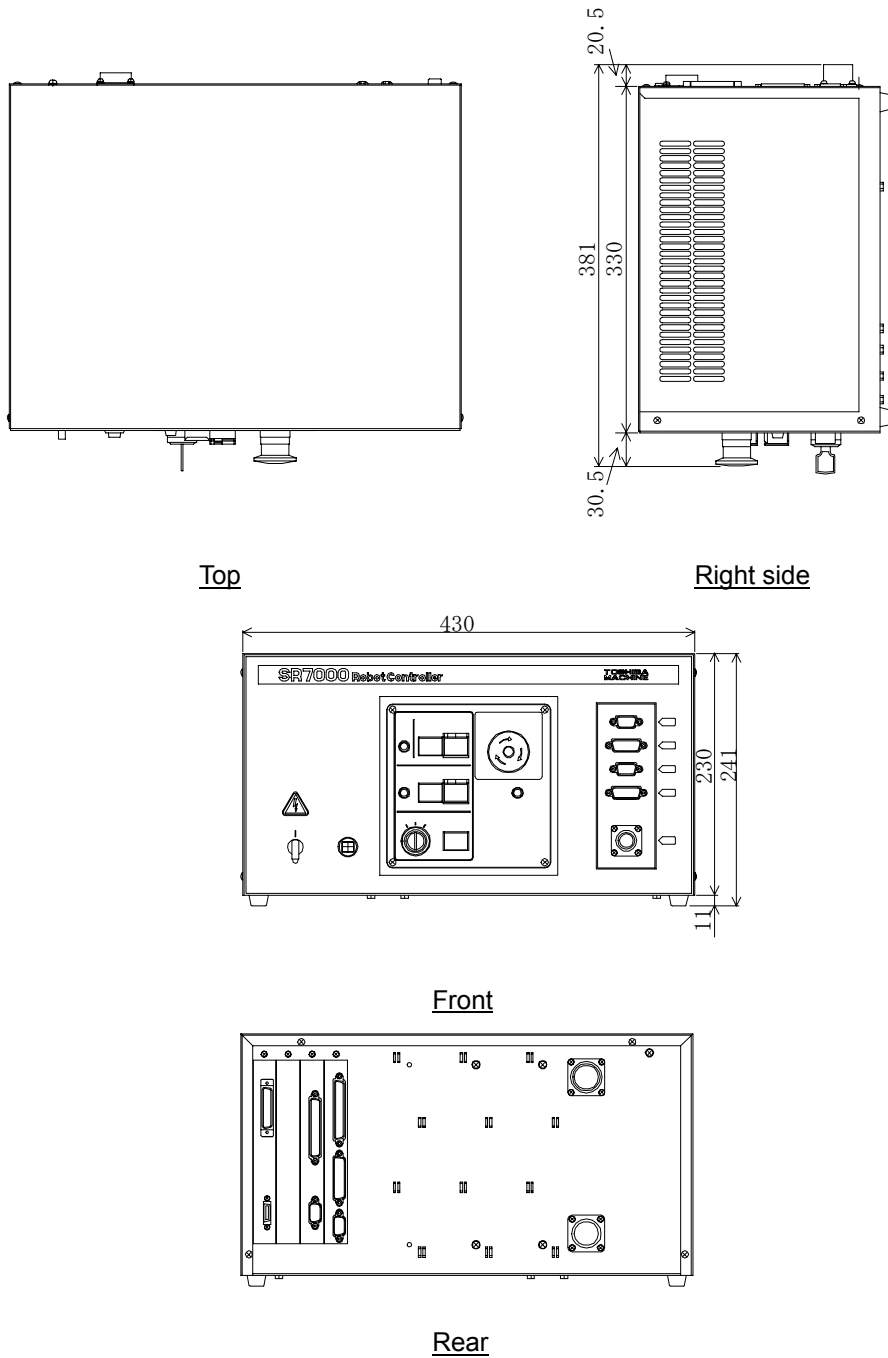

Fig. 2.19 External view of the controller

### 2.3.2 Rack Mounting Dimensions

When mounting the SR-7000 robot controller in a rack, set the side brackets using the screw holes provided on both ends of the front panel, and secure the controller to the rack.

(① in Fig. 2.20: Side brackets are optional.)

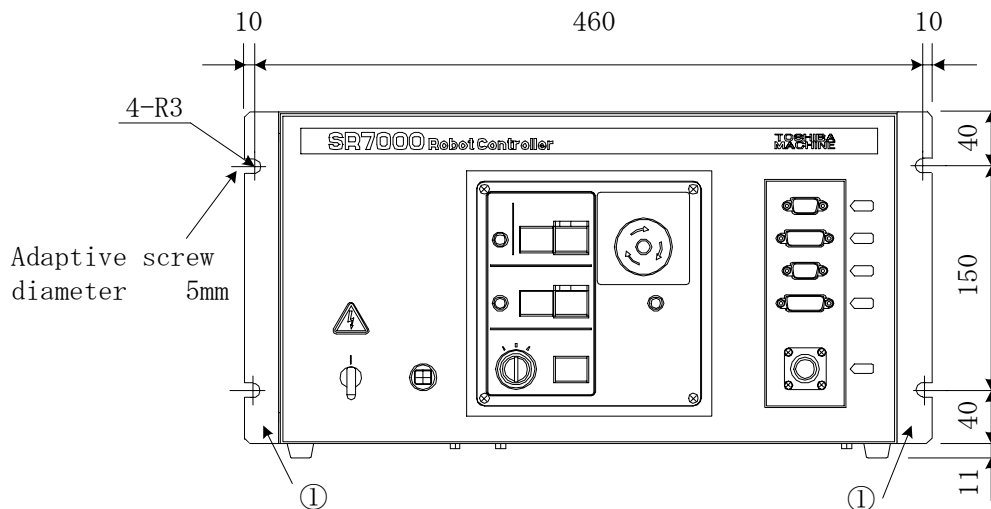

Fig. 2.20 Dimensions of controller rack mounting holes

### 2.3.3 Precautions for Rack Mounting

Pay attention to the following when rack mounting the SR-7000 robot controller.

- (1) When mounting the controller in a rack, use the screw holes provided at both ends of the front panel, and fix the controller. (Optional side brackets are required.)



#### Caution

- If the rack is completely sealed, provide holes to allow the air to be let out, forcibly ventilate the rack with a fan or cool it indirectly so that the heat will not be trapped in the rack. If the heat is trapped in the rack or controller, faults could occur.

- (2) The cable connectors are connected to the rear side of the controller, so provide a space of 110mm at the rear side.

- (3) The upper cover must be removed during maintenance. (See Fig. 2.21.) Keep this in mind when installing the controller. Specifically, the controller should be easily removable from the rack. Practically, be careful of the following points.
- Arrange the cables around the rear panel of the controller (so that the controller can be removed).
  - Arrange the cables between the controller and the control panel when the control panel is separated (so that the controller can be removed).
  - Connect all the cables in a position where the robot can be operated even if the controller is removed from the rack.

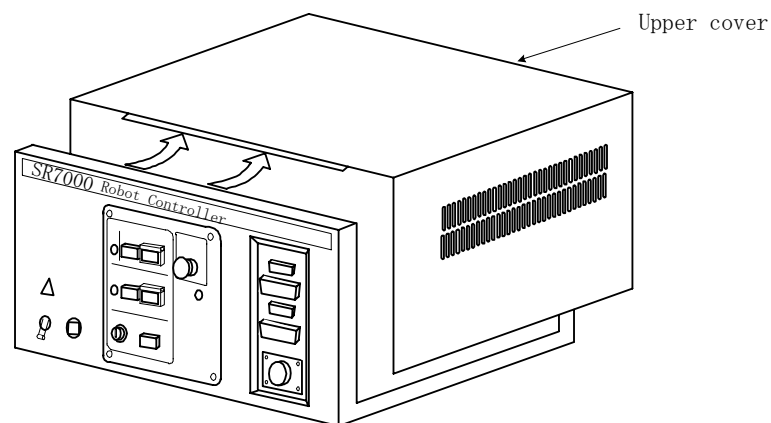

Fig. 2.21 Upper cover

- When the controller is mounted on the rack, the weight of the controller should be supported with the legs of the controller. Screw holes for rack mounting the controller are used for securing the controller panel, and the weight of the controller cannot be supported only with the screws.
- On the front of the controller, a clearance of approx. 90 mm should be provided for connecting the connector of the teach pendant. Even if the teach pendant is not used, a clearance of approx. 50 mm is required for connecting a dummy plug.

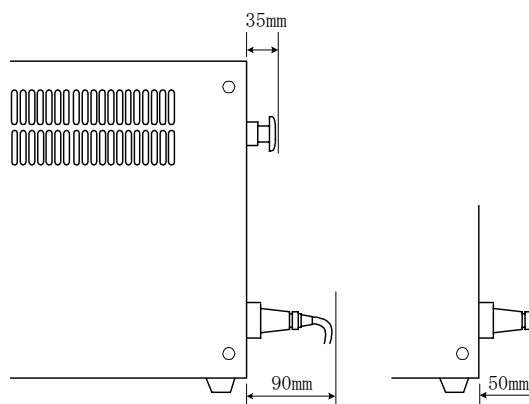



Fig. 2.22 Clearance of front panel of controller

### 2.3.4 Precautions for Direct Installation

When two or more controllers are used, it is necessary to provide a clearance of 50 mm or more in the horizontal direction and a clearance of 100 mm or more in the vertical direction between the controllers.



## Caution

- Provide a ventilation space at the side of the controller so that the air vent holes are not blocked. The space equal to the length of the support should be kept below the lower surface.  
Failure to do so could cause the cooling performance to drop or to faults.
- Do not stack the controllers or place objects in front of it.

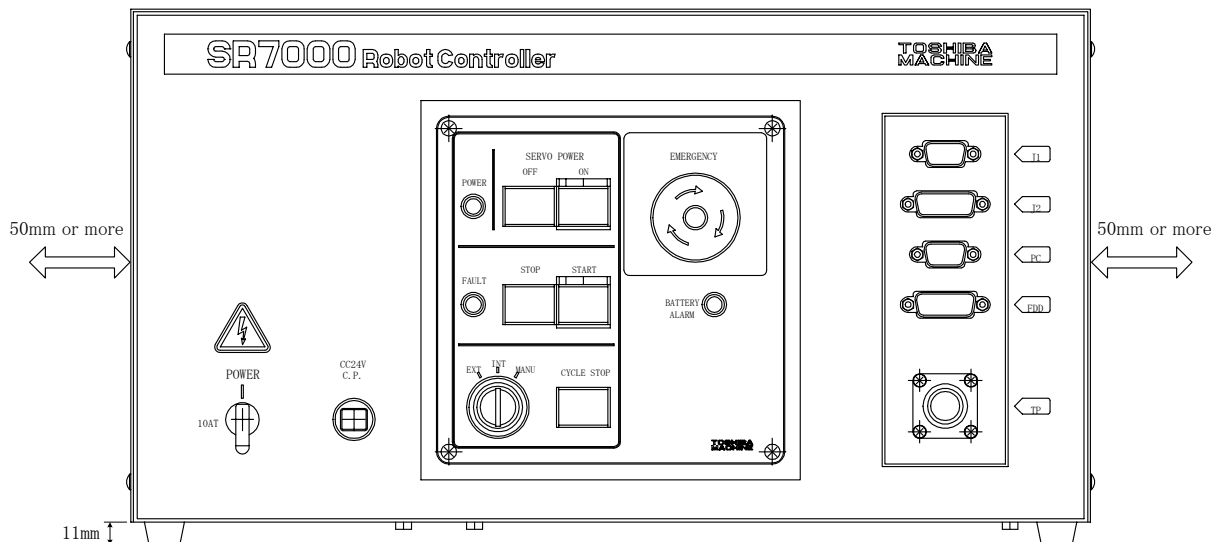



Fig. 2.23 Controller ventilation space

## 2.4 PRECAUTIONS FOR HANDLING THE TEACH PENDANT

Be careful of the following when handling the teach pendant.



## Caution

- Do not drop the teach pendant or hit it against anything.
- Do not pull on the cable protruding from the teach pendant.
- Do not press the switches on the teach pendant with anything sharp (like the tip of a knife, pencil, ball-point pen, etc.).
- Do not place or use the teach pendant near open flames.
- Do not leave the teach pendant in direct sunlight for a long period of time.

## 2.5 SAFETY MEASURES

- (1) When installing the robot, provide sufficient space to carry out the work safely.
- (2) Clarify the hazard zone, and provide a safety fence so that other persons cannot enter the zone easily. The hazard zone is the zone near the robot's working space where a hazardous state could occur if a person enters.
- (3) Provide a limit switch, photo switch or foot switch, etc., at the entrance of the safety fence to provide an emergency stop function that will stop the robot if a person enters the hazard zone. The emergency stop function should be an electrically independent b contact (closed in normal operation) with compulsive opening function and must not be automatically recovered.

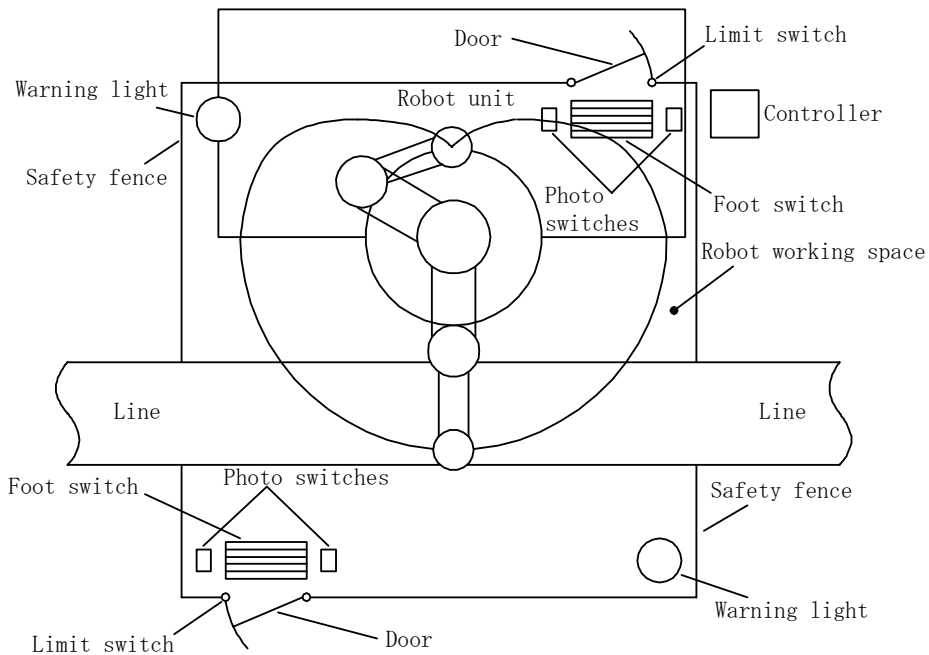

- (4) The controller must be installed at a place outside the hazard zone where the operator can view the robot movement.

## Free Manuals Download Website

<http://myh66.com>

<http://usermanuals.us>

<http://www.somanuals.com>

<http://www.4manuals.cc>

<http://www.manual-lib.com>

<http://www.404manual.com>

<http://www.luxmanual.com>

<http://aubethermostatmanual.com>

Golf course search by state

<http://golfingnear.com>

Email search by domain

<http://emailbydomain.com>

Auto manuals search

<http://auto.somanuals.com>

TV manuals search

<http://tv.somanuals.com>