

Operations Manual

TEC LOAD CELL SCALE
(WITH LABEL PRINTER)

MODEL SL66 SERIES

(US-V Version)

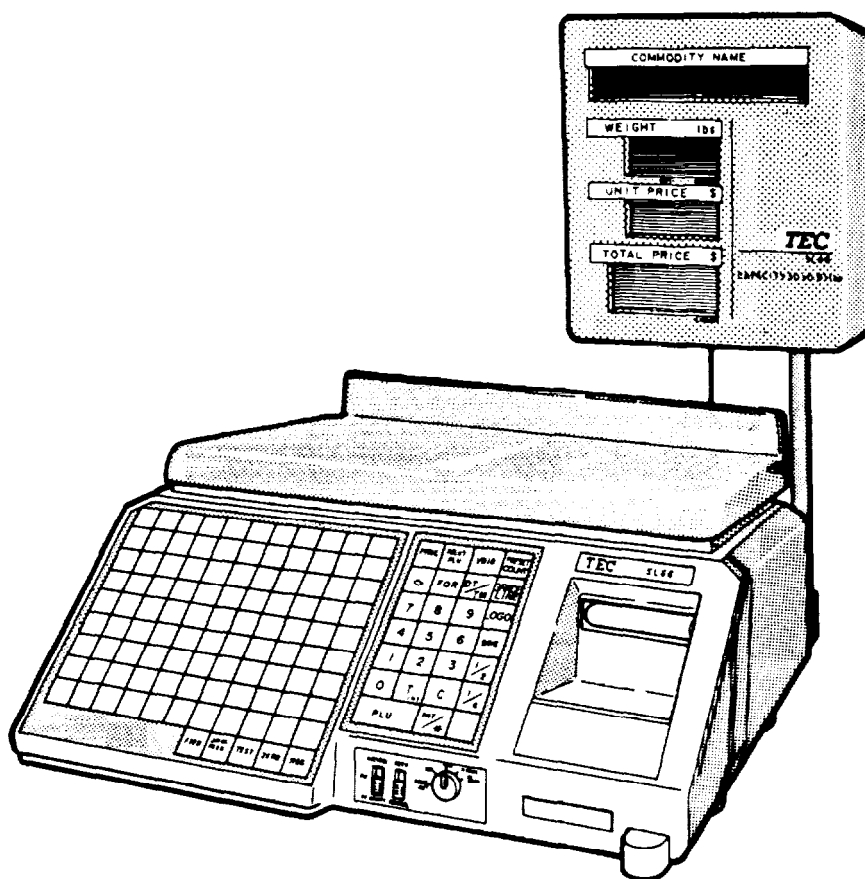

TEC TEC CORPORATION

WARNING

This equipment generates, uses, and can radiate radio frequency energy and if not installed and used in accordance with the instruction manual, may cause interference to radio communications. It has been tested and found to comply with the limits for a Class A computing device pursuant to Subpart J of Part 15 of FCC Rules, which are designed to provide reasonable protection against such interference when operated in a commercial environment. Operation of this equipment in a residential area is likely to cause interference in which case the user at his own expense will be required to take whatever measures may be required to correct the interference.

TABLE OF CONTENTS

	Page
● INTRODUCTION	1
● PRECAUTIONS	1
1. SPECIFICATIONS	2
2. OVERVIEW	3
3. REMOTE DISPLAY	3
4. KEY LAYOUT	4
5. KEY AND LAMP FUNCTIONS	4
6. CONTROL LOCK	7
7. LEVEL ADJUSTMENT	8
8. CLEANING THE PRINT HEAD	8
9. REMOVAL AND REPLACEMENT OF LABEL ROLL	9
10. NOTES BEFORE STARTING OPERATIONS	10
11. OPERATION PROCEDURE	11
11- 1. Weighed Article Registration	11
11- 2. By Count Registration	13
11- 3. Fix Price Registration	15
11- 4. Preset Count Registration and Operation	17
11- 5. Issuing Net Weight Label	22
11- 6. Tare Function Procedure	24
11- 7. SAVE Key Operation Sample	27
11- 8. VOID Key Operation Sample	28
11- 9. Date Change	29
11-10. Selection of Print Item on Registration Label	30
11-11. Setting Automatic Display Switching Time	31
11-12. Calling and Printing Grade Line	32
11-13. Calling and Printing Logo	33
11-14. FUN Automatic Reception	34
12. TOTAL OPERATION PROCEDURES	36
12- 1. Hourly Report	36
12- 2. Grand Total Report	37
12- 3. PLU Report	38
12- 4. Combination Report	42
13. ACTION FOR ERROR MESSAGES	44
14. LABEL PRINT FORMATS	46
15. BEFORE YOU CALL FOR SERVICE	50
16. APPENDIX	51

INTRODUCTION



We thank you very much for purchasing the TEC Electronic SL66 Series Scale.

This series has been designed with TEC reliability to offer a cost efficient system for a modest investment.

The SL66 (with thermal printer) takes advantage of the latest technology in microprocessors. Because of this, the decreased cabinet size permits the system to be placed virtually anywhere in your store. Your deli and specialty departments can enjoy these high quality reliable TEC products. Improve your operating effectiveness and watch the increased utilization of your front end scanning investment. This electronic Load Cell scale eliminates all moving parts and furnishes an accurate digital display of all information.

We believe that your needs will now be fully satisfied, and you will have total reliability in price calculation. Should you have any questions concerning the scale, please refer to this manual. Be sure to keep this manual for future reference.

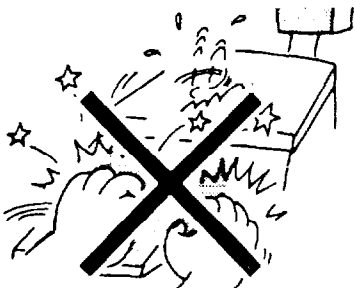
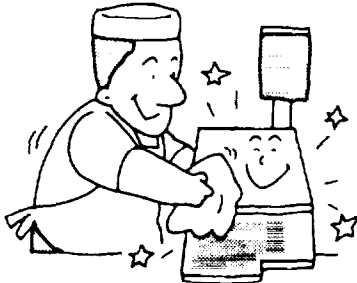
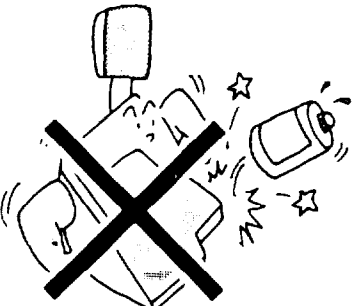
PRECAUTIONS

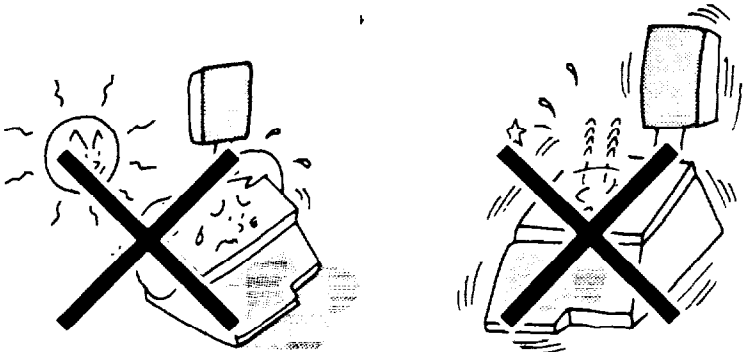
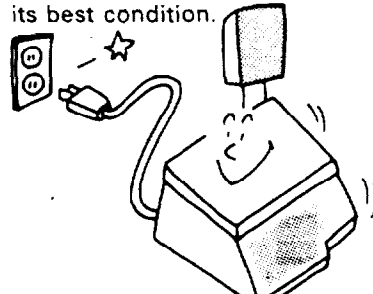
<p>1. DON'T SUBJECT the weighing platter to SUDDEN SHOCKS.</p> 	<p>2. DON'T PRESS THE KEYS TOO HARD. Keys will operate correctly if they are merely touched lightly.</p> 	<p>3. Clean the cover and platter by wiping with a dry cloth or a cloth soaked with detergent and wrung out thoroughly.</p> 
<p>4. NEVER USE THINNER OR OTHER VOLATILE SOLVENT for cleaning.</p> 	<p>5. DON'T POUR WATER directly on scale.</p> 	<p>6. To ensure the scale is operating correctly, place a known weight on the platter and check for correct computing.</p> 
<p>7. When in use, avoid locations subject to vibration and direct sunlight.</p> 		<p>8. After the end of daily work, turn the power OFF, then clean and inspect the exterior of the scale to allow you to use the scale at its best condition.</p> 

1. SPECIFICATIONS

Items	SL66-30L-US-V
Maximum Capacity	30 lbs
Minimum Scale Division	0.01 lbs.
Using Weight Range	0.20 ~ 30 lbs.
Display Range	0 ~ 30.05 lbs
Tare	0.01 ~ 30 lbs.
Unit Price presettable	\$0.01 ~ 99.99
Minimum Price Display	\$0.01
Power Requirement	AC 120V \pm 10%, 60 Hz
Current Consumption	120V 1.5A 60 Hz
Temperature Limits	32° ~ 104°F
Relative Humidity	35% ~ 85% RH (No condensation)
Dimensions (approx.)	15.7" (W) \times 17.2" (D) \times 18.7" (H)
Weight	33.1 lbs.
Remote Display	4 digits
Weight	
Unit Price	4 digits
Total Price	5 digits
Message	22 characters (16 \times 176 dot matrix)
Display Designations	NET, PREPACK, ERROR
Remote Display Mode	Dual sides
Capacity of PLU Memory	Refer to below table.
Print Head	Thermal Print Head
Label Issuing Method	On-demand/Batch
Label	RICOH 120LA or equivalent
Interface Device (option):	
Cassette Magnetic Tape Loader	AIWA DR-1
PC Keyboard	A FUJITSU PC Keyboard (FKB-2831-001) instead of the IBM PC-XT Keyboard can be used. For use of other units, please contact your TEC representative.

Capacity of PLU Memory

Type	Capacity of PLU
US-V	Max. 1400 PLUs

Option Kits

Name of Kit	Purpose
OP-66-32K	Expansion RAM Kit
OP-66-TMCC	Communication I/F Kit (TMCC-3)
OP-66-PCKEY	IBM PC-XT keyboard connection adapter
KS-60-1	Label cassette case
OP-66-PL	Program Loader
OP-66-PL-TMCC	Program Loader with Communication I/F (TMCC-3)
OP-66-PIGGY	Expansion RAM board
MC-128-EX	Memory Card (128 KB)
MC-256-EX	Memory Card (256 KB)

**TMCC = TEC Multi-drop
Communication Control**

2. OVERVIEW

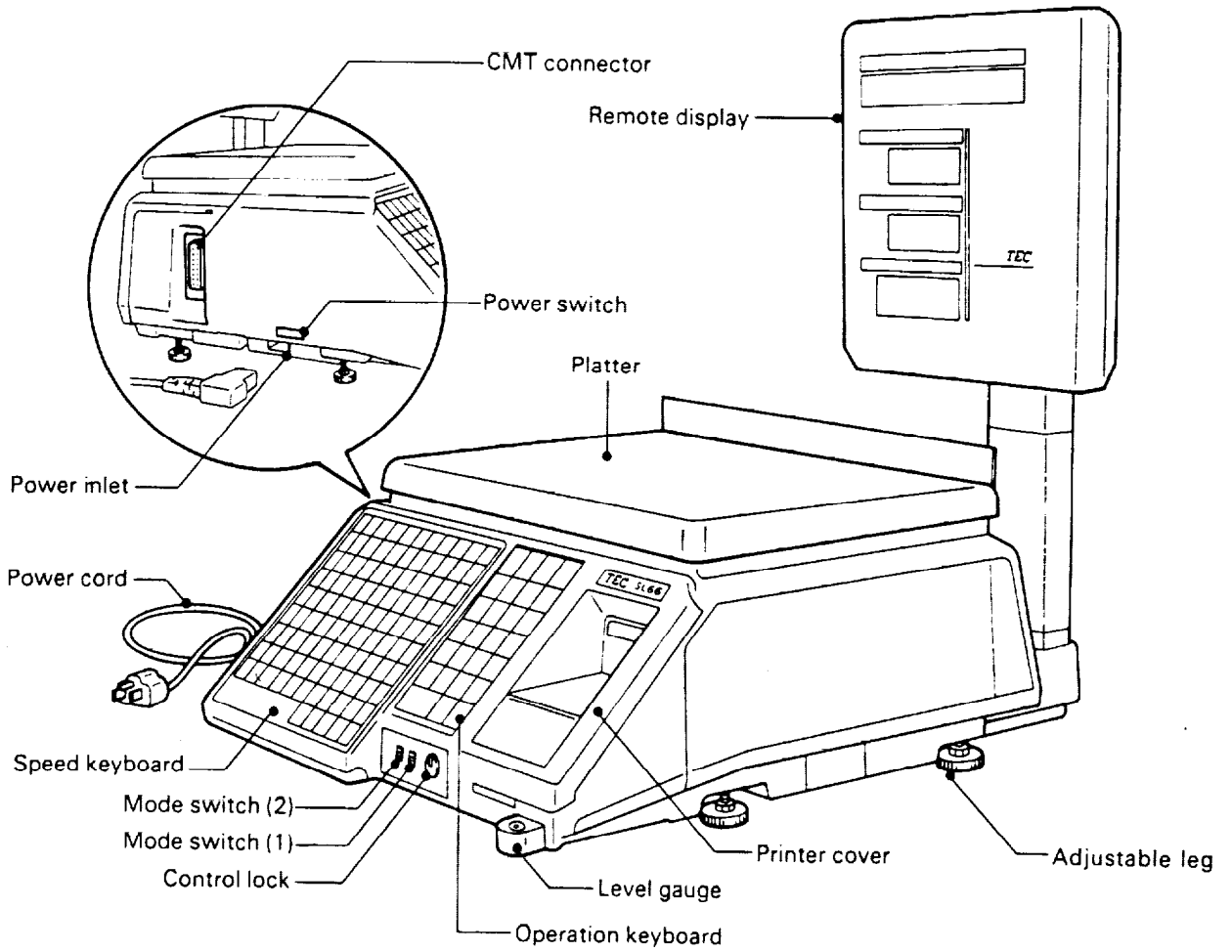

3. REMOTE DISPLAY

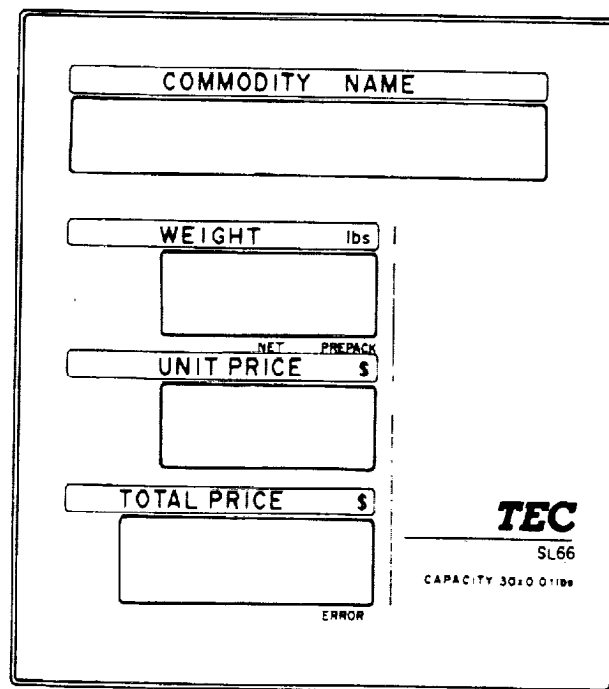



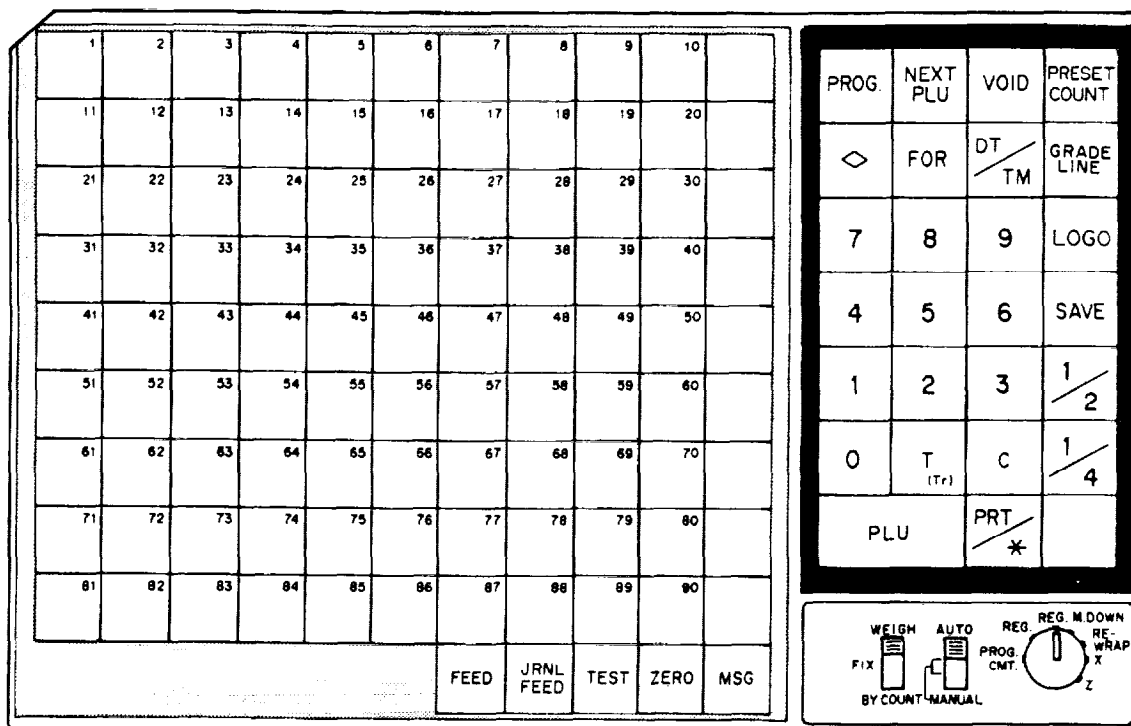





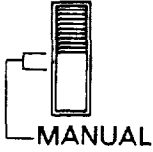

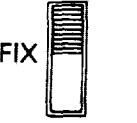







4. KEY LAYOUT















NOTE: The characters (1 ~ 90) indicated on the speed keys are shown for the convenience of explanation in this manual. The indications on the actual unit are not as shown in this illustration.

5. KEY AND LAMP FUNCTIONS

Name of Key & Lamp	Function
Mode Switch (1) AUTO  MANUAL	<p>"AUTO" position: This position is used to issue regular scale labels. When the weight becomes stable, the label will automatically be issued.</p> <p>"MANUAL" position: When the weight becomes stable, the label will be issued by depressing the  Key.</p>
Mode Switch (2) WEIGH FIX  BY COUNT	<p>"WEIGHT" position: This position is used in the weighing function of the SL66.</p> <p>"FIX" position: The Unit Price is entered directly to the Total Price on calling up PLU, and that Total Price cannot be changed by any subsequent weighing.</p> <p>"BY COUNT" position: It is possible to produce labels which contain information on quantity pricing, instead of weight.</p>
NUMERIC Keys 	These keys are used to enter PLU Number, Unit Price, and Tare weight.

Name of Key & Lamp	Function
CLEAR Key 	This key is used for clear-entry of numeric keys, return the scale condition to the normal weighing mode, release the scale from the SAVE or ERROR mode, and suspend batch printing.
TARE Key 	This key is used to subtract tare weight.
PLU Key 	This key is used to select a PLU number or return to the initial mode.
PRINT/VERIFY Key 	For issuing Total labels. If the Label issue mode switch is set to the MANUAL position, it has the function of label issue. It is also used to resume batch printing if it has been suspended.
1/2 Key  1/4 Key 	These keys are used to calculate the unit price by 1/2lbs or 1/4lbs.
SAVE Key 	This key is used to save tare and unit price after removing the commodity from the platter.
DATE & TIME Key 	This key is used for temporary date changes.
GRADE LINE Key 	This key is used to call the grade line message.
FOR Key 	In the "X" or "Z" control lock position, this key is used to generate the Zone Total Report.
VOID Key 	One article's data can be cancelled by depressing this key after its registration. It is also used to return the operation step to the previous step.
NEXT PLU Key 	This key is used to call out the next PLU #, and forward the operation step to the next step.
	In the "X" or "Z" control lock position, this key is used to generate the Block Total Report. In the "REG." control lock position, this key is used to select whether the data should be printed on the label or not.
PROGRAM Key 	This key is used to set the various programs.

Name of Key & Lamp	Function
SPEED Key  ~ 	These keys are used to set and call the PLU numbers of frequently used articles.
FEED Key 	This key is used to feed labels or journal paper.
JOURNAL FEED Key 	This key is not used. (No function)
TEST Key 	This key is used to issue Test Labels.
ZERO Key 	This key is used to adjust the ZERO point.
MESSAGE Key 	This key is not used. (No function)
PRESET COUNT Key 	This key is used to preset the number of issuing labels.
LOGO Key 	This key is used to call the logo data.
NET Lamp 	Lights when tare is subtracted.
PREPACK Lamp 	Lights when the SAVE key is depressed.
ERROR Lamp 	Lights when this machine is improperly operated or there is a function error.

6. CONTROL LOCK

The control lock has seven marked positions.

There are two control keys which will operate these locks.

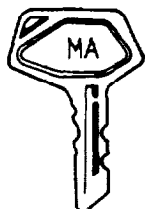

- **Manager Key**
This key (MA) will access the PROG/CMT, REG, M. DOWN, and REWRAP positions.

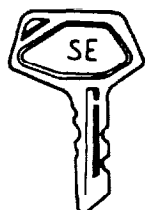

- **SE Key**
This key (SE) will access all seven positions.

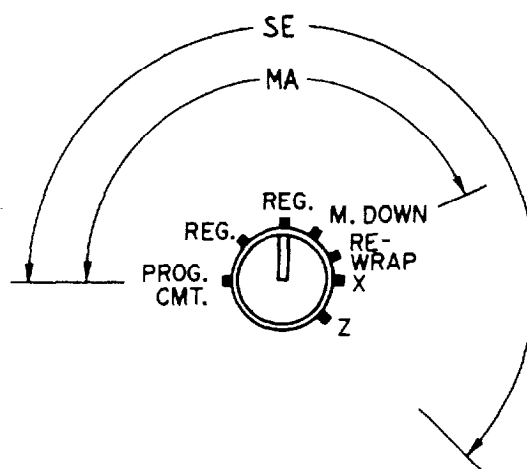

Each of the following positions on the control lock serves a different function.

- PROG. CMT.** ——— With the manager key in this position, it is possible to program data in the PLU file, Store Address, Message, Printing Position, Date, Time, Initial Set, and Bar Code Format, etc., may also be programmed.
- REG.** ——— These positions are the normal control lock positions which allow the issuance of printed labels.
- M. DOWN** ——— In the Markdown position, it is possible to designate an item for discount pricing.
- REWRAP** ——— In the Rewrap position, it is possible to designate an item for rewrapping products.
- X (Read)** ——— This position is used to read all the accumulated sales totals stored in the unit. These totals include individual item totals, group totals, hourly totals, and the entire file totals.
- Z (Reset)** ——— This position is used to reset all item file totals.

7. LEVEL ADJUSTMENT

Set the scale on a stable and level surface. Level the scale by turning the adjustable legs so that the air bubble is inside the center circle.

Level Gauge

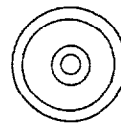

Correct

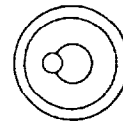

Incorrect

When the air bubble moves toward the left side, turn the right adjustable legs clockwise.

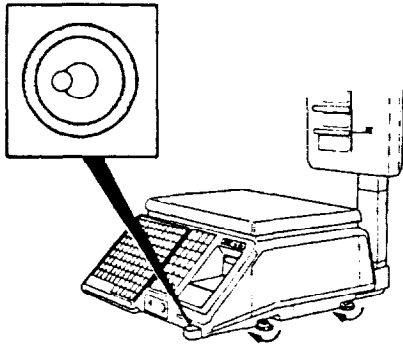

When the air bubble moves toward rear, turn the front adjustable legs clockwise.

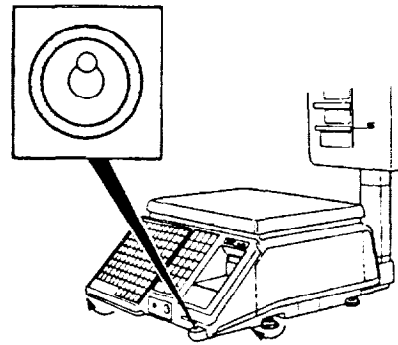

8. CLEANING THE PRINT HEAD

If the print head is dirty, clear printing will not be produced. It is recommended to clean the head with the thermal head cleaner every day before starting operation using the following procedure:

1. Remove the printer cover and label cassette. Then push the head-up lever in the direction indicated by the arrow.

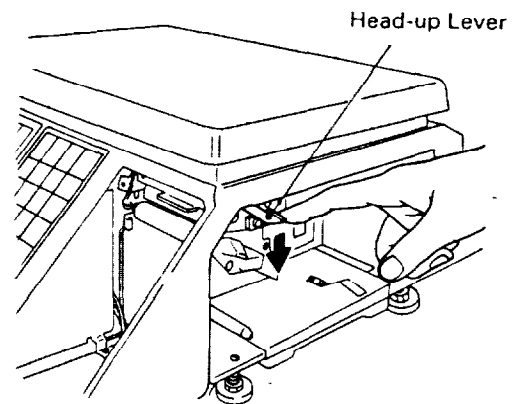

2. Wipe off the dirt on the darkened portion in the diagram with the thermal head cleaner. Then set the label cassette, and push down the print head.
NOTE: Be careful not to damage the print head when cleaning.

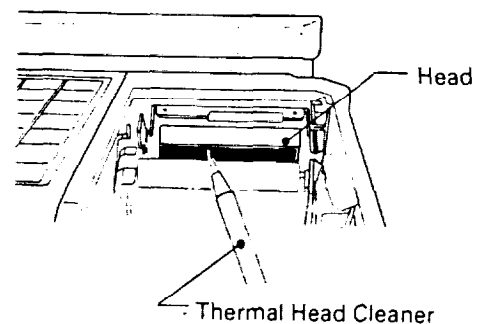

9. REMOVAL AND REPLACEMENT OF LABEL ROLL (for On-demand printing mode)

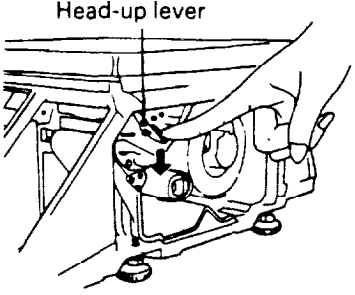
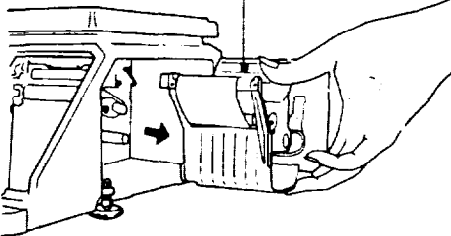
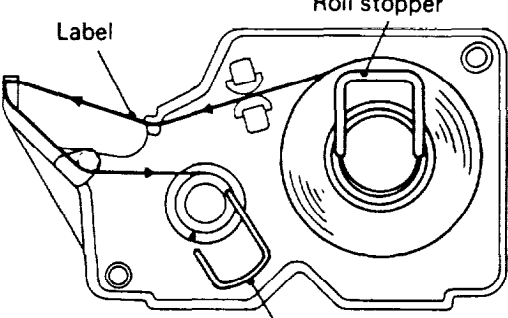
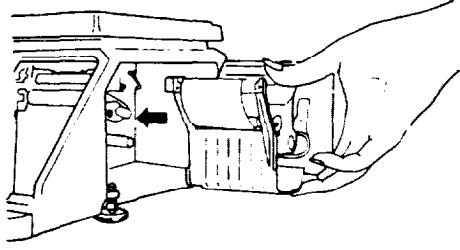
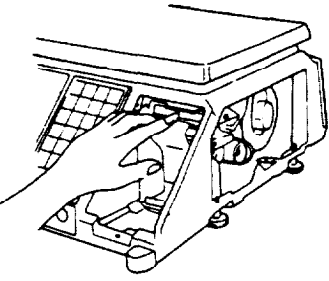
<p>1. Remove the printer cover and right side cover. Then push the head-up lever in the direction indicated by the arrow.</p>	 <p>Head-up lever</p>
<p>2. Pull out the label cassette and remove the core of the label roll and the label backing paper. NOTE: To remove the label backing paper, loosen the paper by turning the paper winding shaft counterclockwise and remove the paper stopper.</p>	 <p>Label cassette</p>
<p>3. Referring to the figure on the right, set the label roll on the label cassette.</p>	 <p>Label</p> <p>Roll stopper</p> <p>Backing paper stopper</p>
<p>4. Set the label cassette.</p>	
<p>5. Push down the print head, and close the covers. NOTE: When the label roll is replaced, press the feed key to confirm that the label is issued correctly.</p>	

● Label (for Batch printing mode) and Report Paper Threading

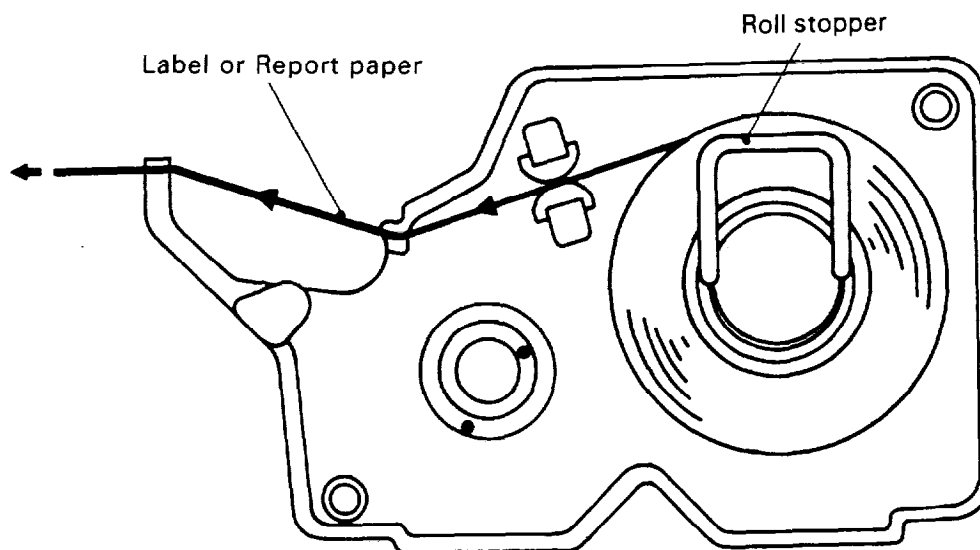

10. NOTES BEFORE STARTING OPERATION

- (1) Be sure to plug the power plug into an AC outlet.
- (2) When the power switch is turned on, the scale goes through the test scanning sequence, such as 0000, 0000, 0000, then 1111, 1111, 11111..... and zeros appear on the displays.
- (3) While the scale is in the test sequence, do not put anything on the platter.
- (4) Do not move the unit while it is in operation. Should it become necessary to move it at any time, turn the power switch to the OFF position and be sure to readjust the level indicator after relocating the scale.
- (5) Should a power failure occur during operation, remove the commodity from the platter and insert the power plug into an AC outlet again when power is restored.
- (6) If the scale is used with an unrated power source, inaccurate scaling or other errors may occur.
- (7) If the Zero Point has shifted during scaling, and no tare is displayed, adjust the Zero Point by depressing the Zero key.

11 OPERATION PROCEDURE

11-1. Weighed Article Registration

Control lock : REG, M.DOWN, or REWRAP

Mode SW(2) : WEIGH

Example A) In the case of an article for which PLU # 100 and a unit price of \$3.00/lb are set in speed key 1.

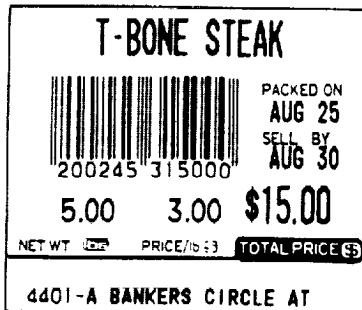
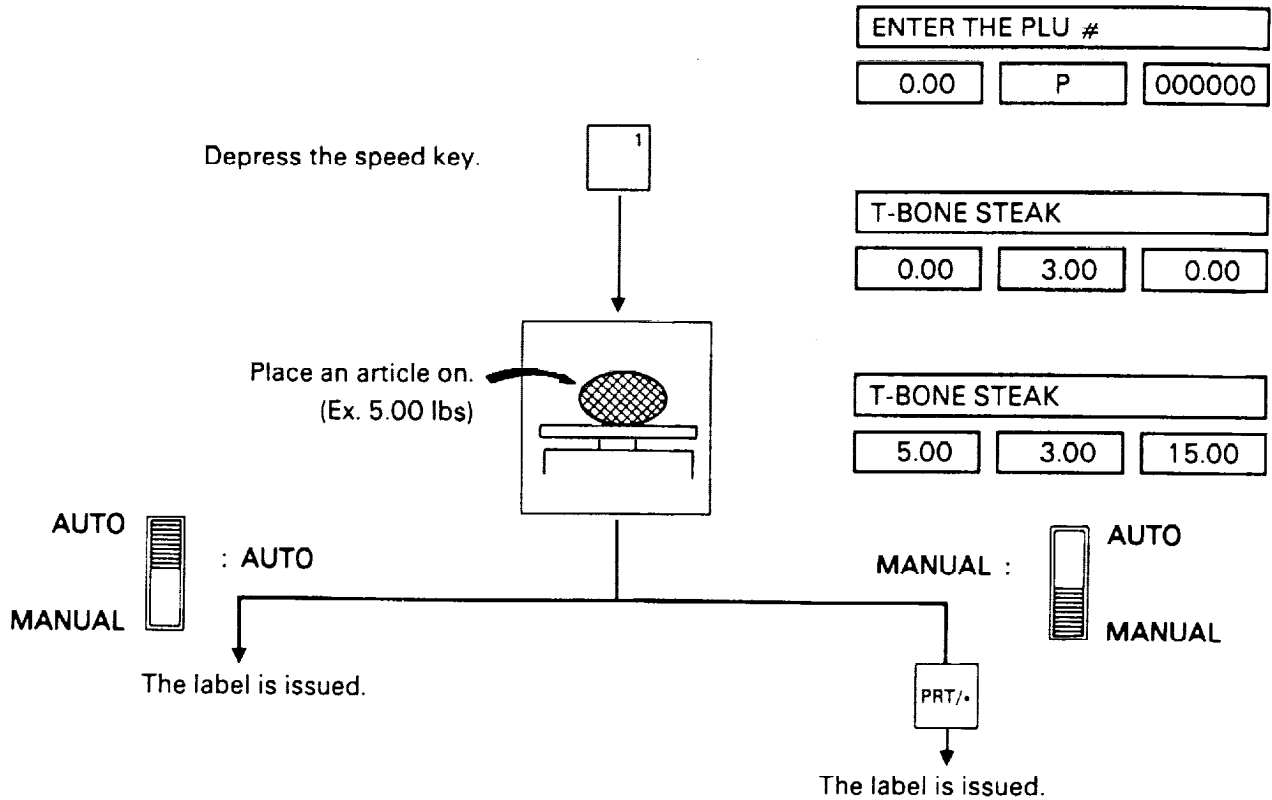

(Sample label)

NOTE: Depressing a speed key which is not stored in PLU data beforehand causes the scale to enter an error mode.

Example B) In the case of an article for which a unit price of \$2.50/lb is set for PLU # 505.

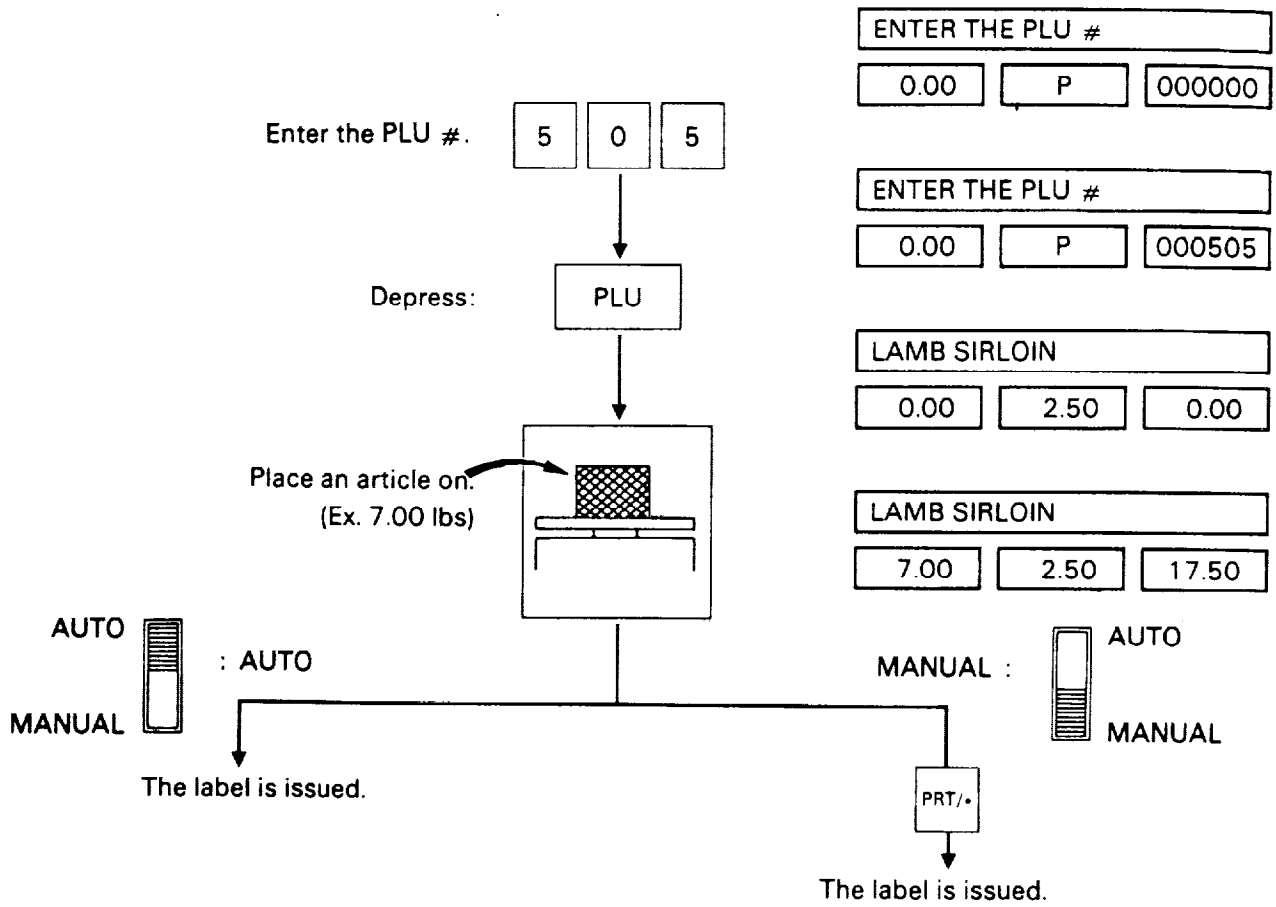

(Sample label)

11-2. By Count Registration

Control lock : REG, M.DOWN, or REWRAP
 Mode SW(2) : BY COUNT

Example A) In the event that a price of \$1.80/12 pcs is set for PLU #106.

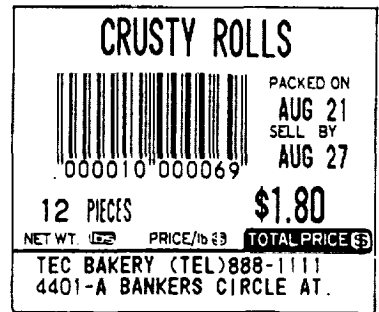
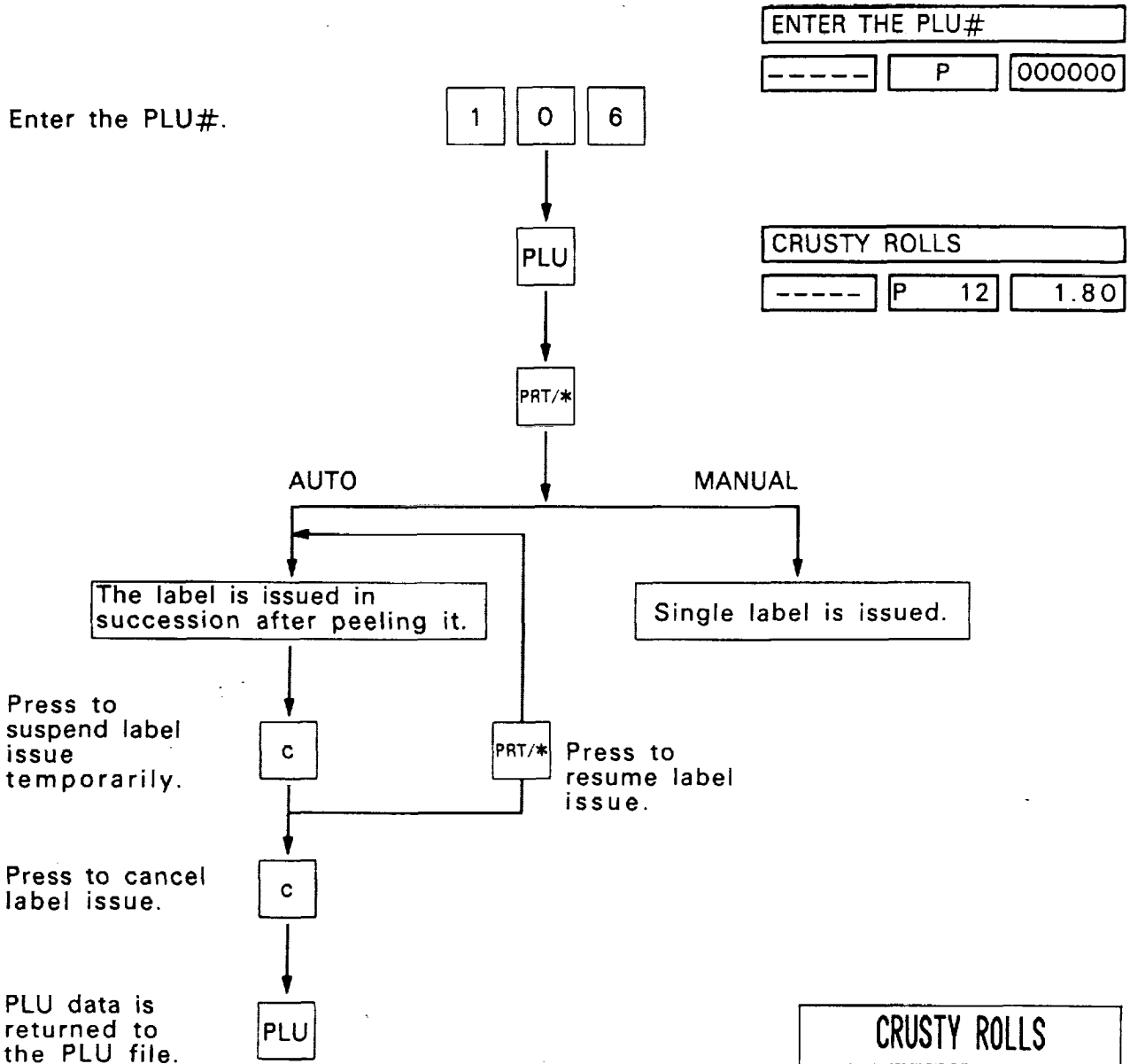

(Sample label)

Example B) In the case of purchasing 20 pcs of an article for \$ 1.00 of price for 4 pcs. (In the event that a price of \$ 1.00/4 pcs is set for PLU #113.).....**SPLIT PRICE**

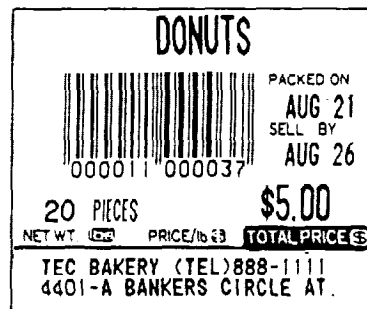
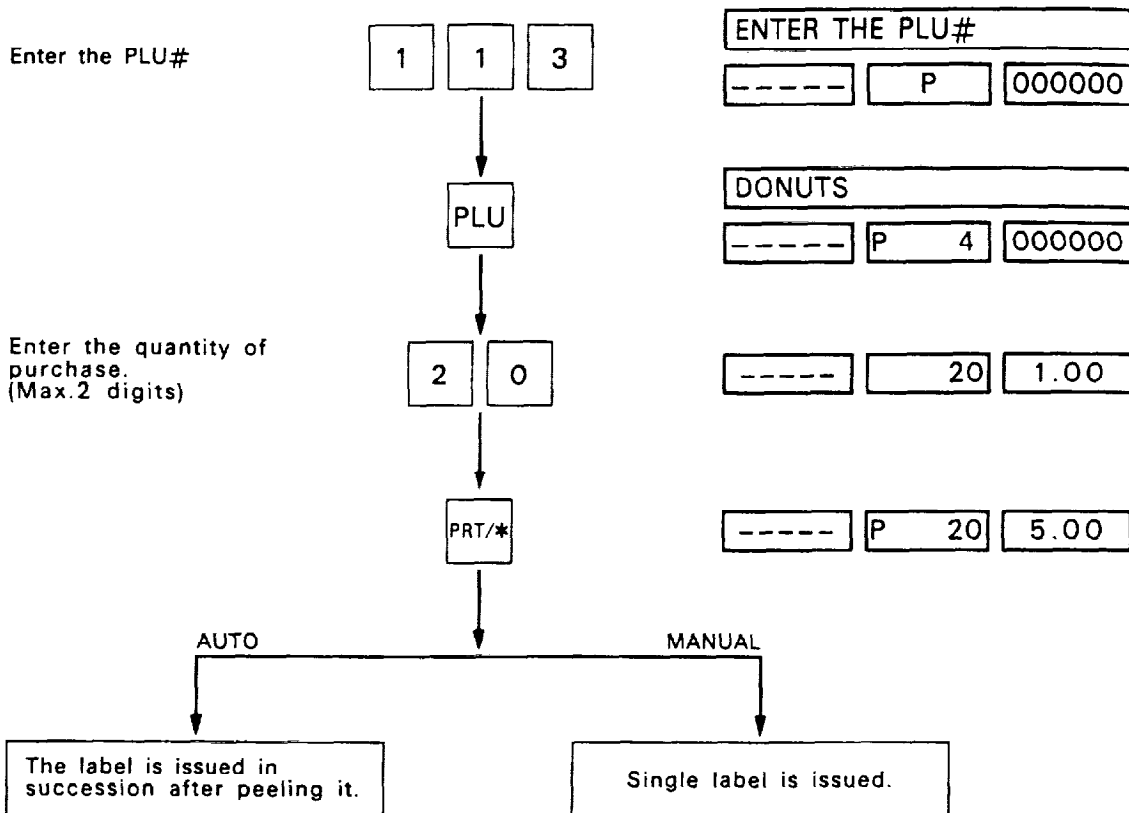

(Sample label)

11-3. Fix Price Registration

Control lock : REG, M.DOWN, or REWRAP

Mode SW(2) : FIX

Example A) In the event that PLU #3036 and a unit price of \$3.80/lb are set in speed key 7.

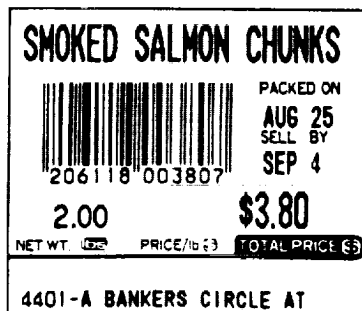
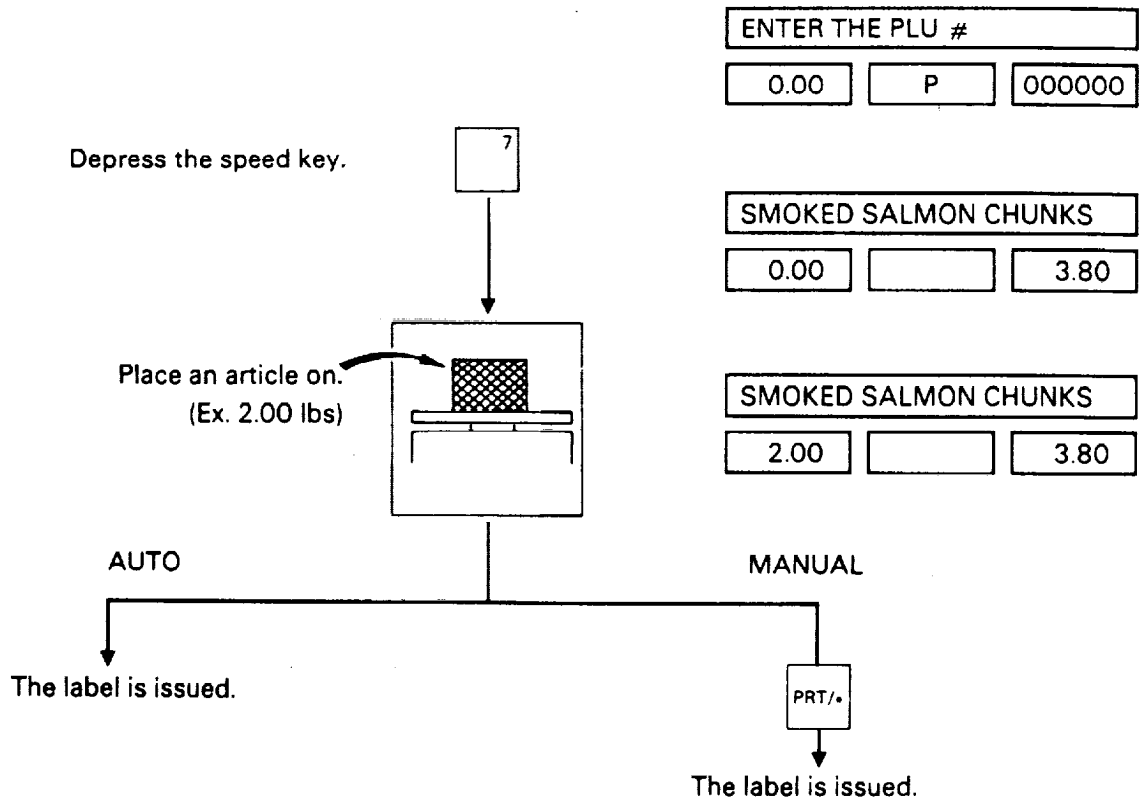

(Sample label)

Example B) In the event that an open unit price is set for PLU # 205.

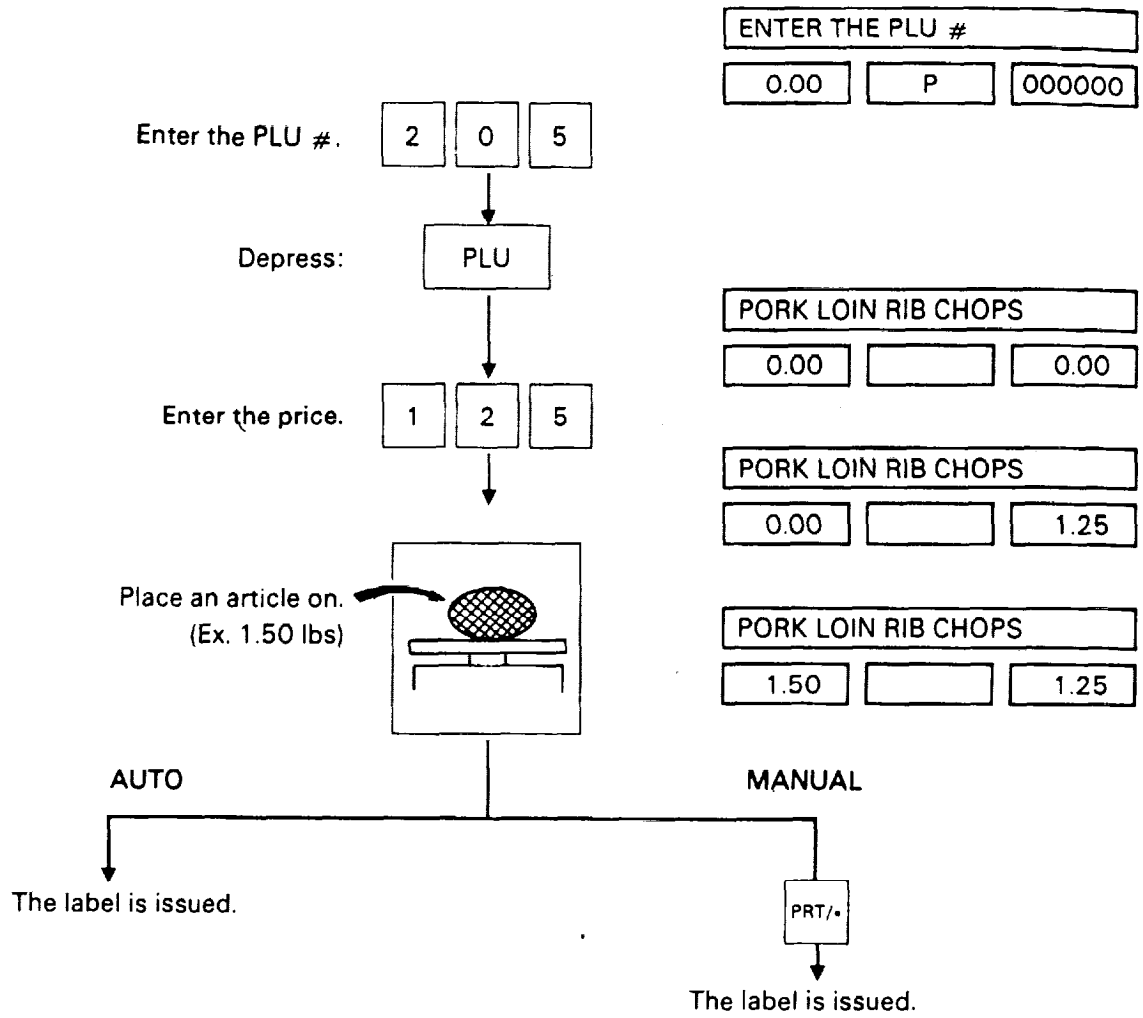

(Sample label)

11-4. Preset Count Registration and Operation

Control lock : REG, M.DOWN, or REWRAP

Mode SW(2) : WEIGH, BY COUNT, or FIX

Example A) When Mode SW. (2) is at the "WEIGH" position

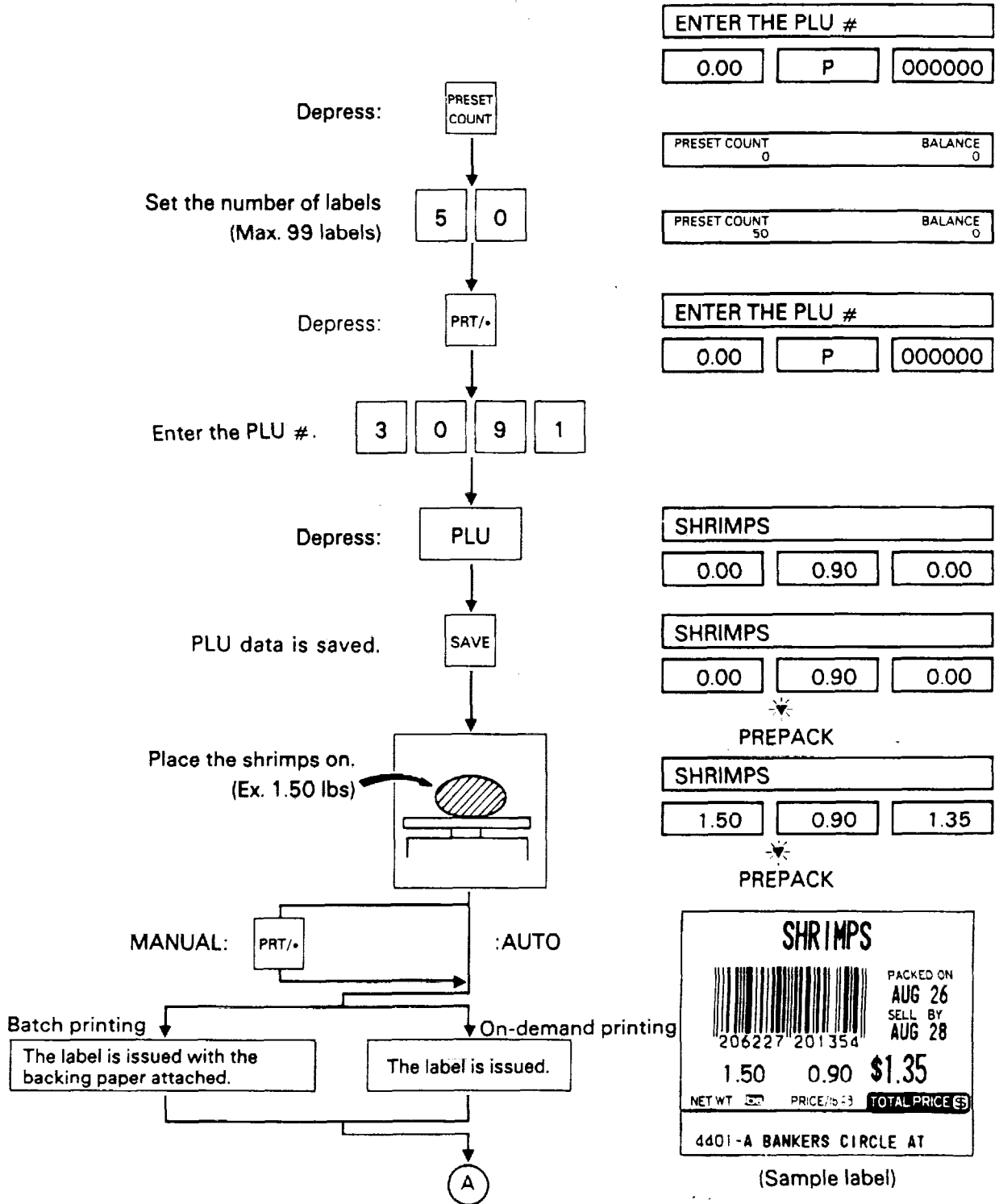

(continued on next page)

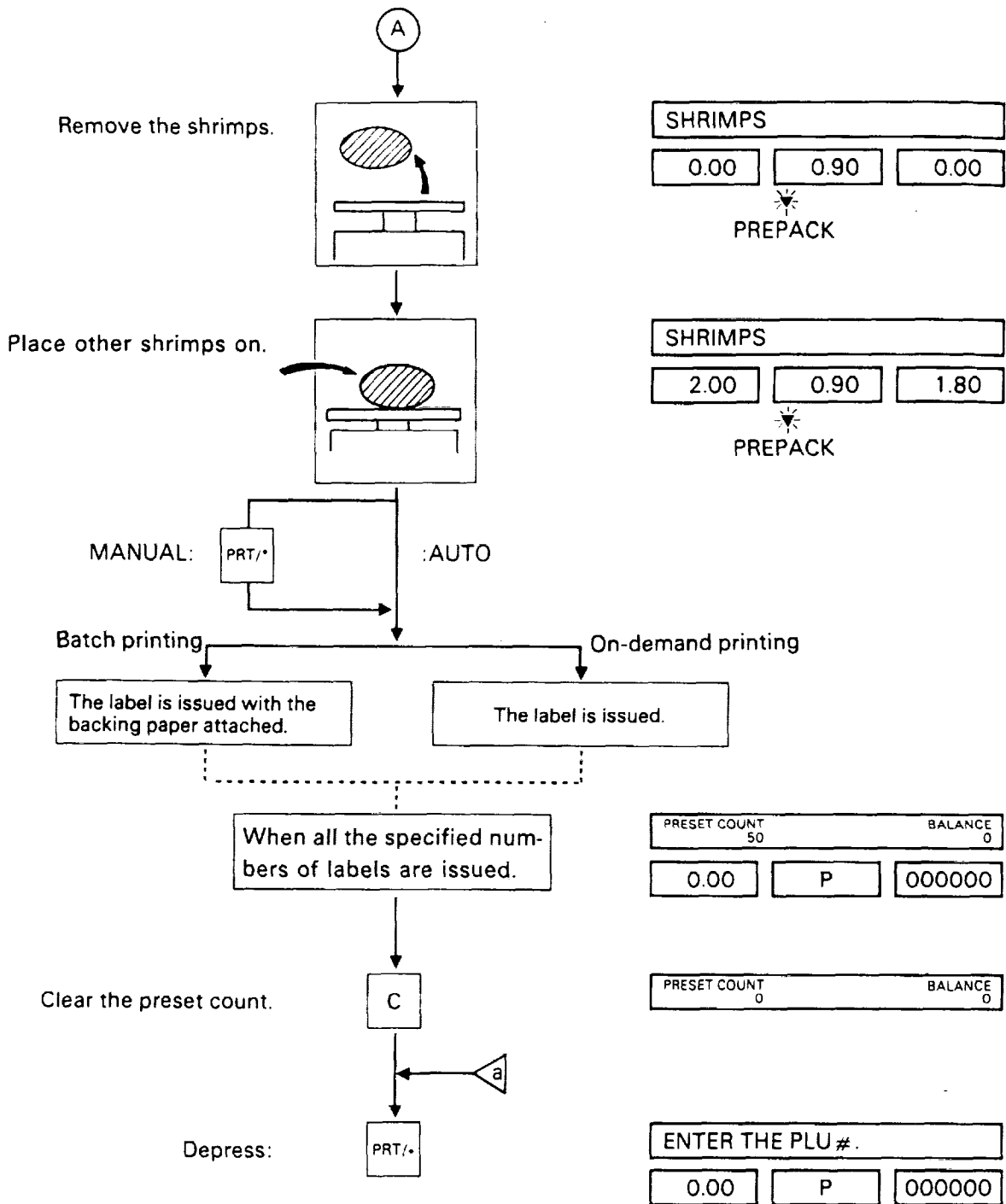

CAUTION: If the setting of the Control Lock or Mode SW. (2) is changed during operation, the specified number of the label is cleared.

NOTE: To check the remaining number of the specified label during operation or to cancel the specified number of the label.

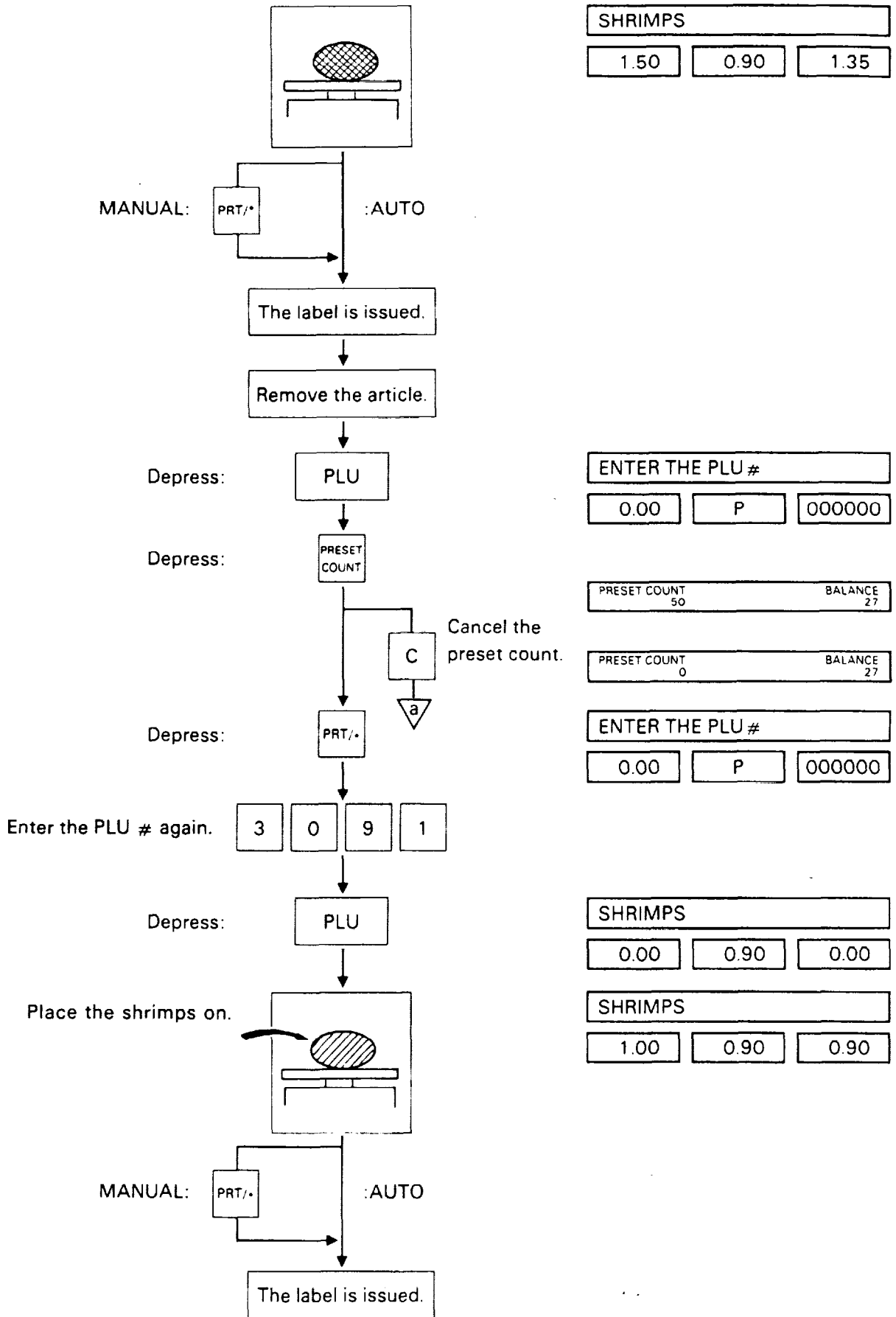

Example B) When Mode SW. (2) is at the "FIX" position.

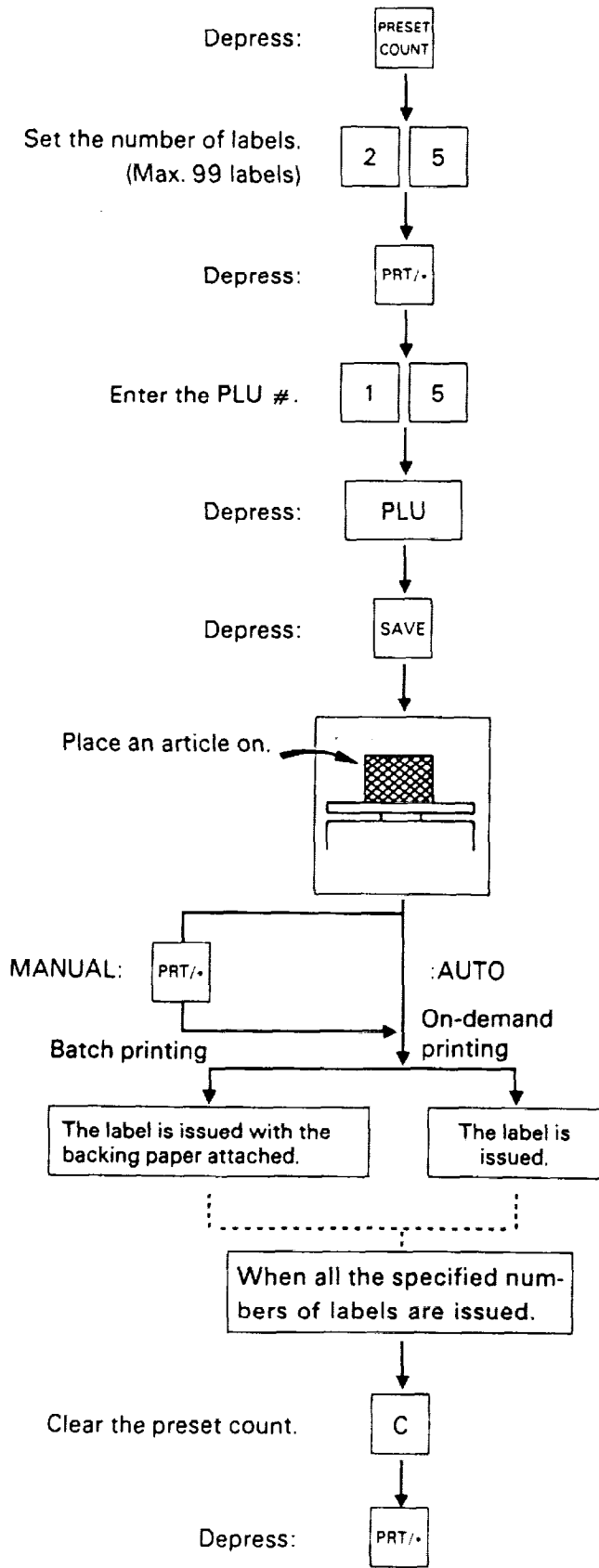

ENTER THE PLU #		
0.00	P	000000

PRESET COUNT	BALANCE
0	0

PRESET COUNT	BALANCE
25	0

ENTER THE PLU #		
0.00	P	000000

MILD CHEDDAR		
0.00		0.80

MILD CHEDDAR		
1.32		0.80

PREPACK

MILD CHEDDAR	
	PACKED ON AUG 26 SELL BY SEP 1
201320 200808	
1.32	\$0.80
NET WT 1.25	PRICE/lb 23
TOTAL PRICE \$	
4401-A BANKERS CIRCLE AT	

(Sample label)

PRESET COUNT	BALANCE
25	0

0.00	P	000000
------	---	--------

PRESET COUNT	BALANCE
0	0

ENTER THE PLU #		
0.00	P	000000

Example C) When Mode SW. (2) is at the "BY COUNT" position.

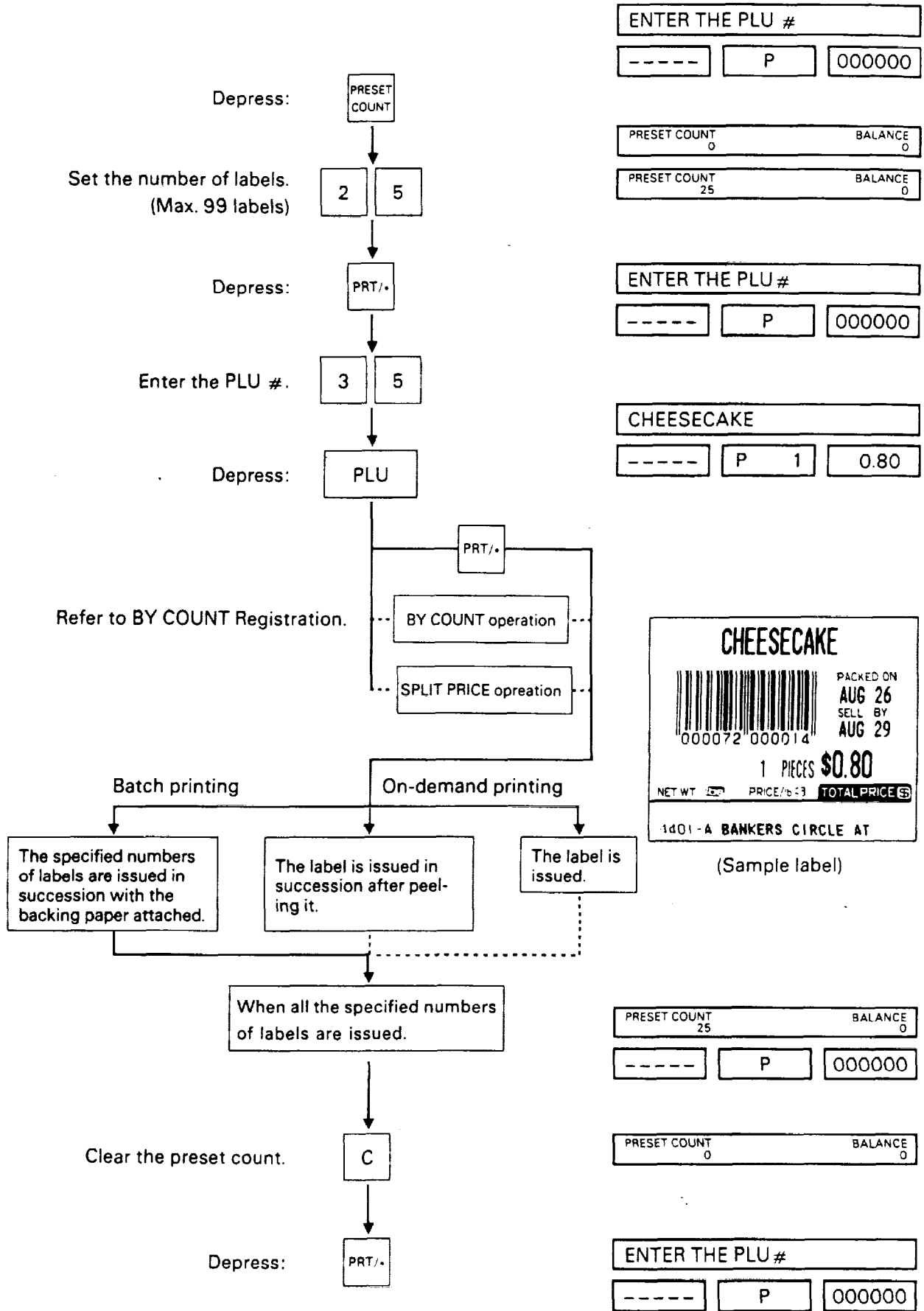

11-5. Issuing Net Weight Label (initial set change will be required)

The unit price and tare weight those are programmed in the PLU will be used as Price and Net Weight.

The value of the price and net weight could be changed by numeric keys entry.

Control lock : REG, M.DOWN, or REWRAP

Mode SW(2) : FIX

Example) In the event that a unit price of \$2.10 and tare weight of 1 lb are set for PLU #116.

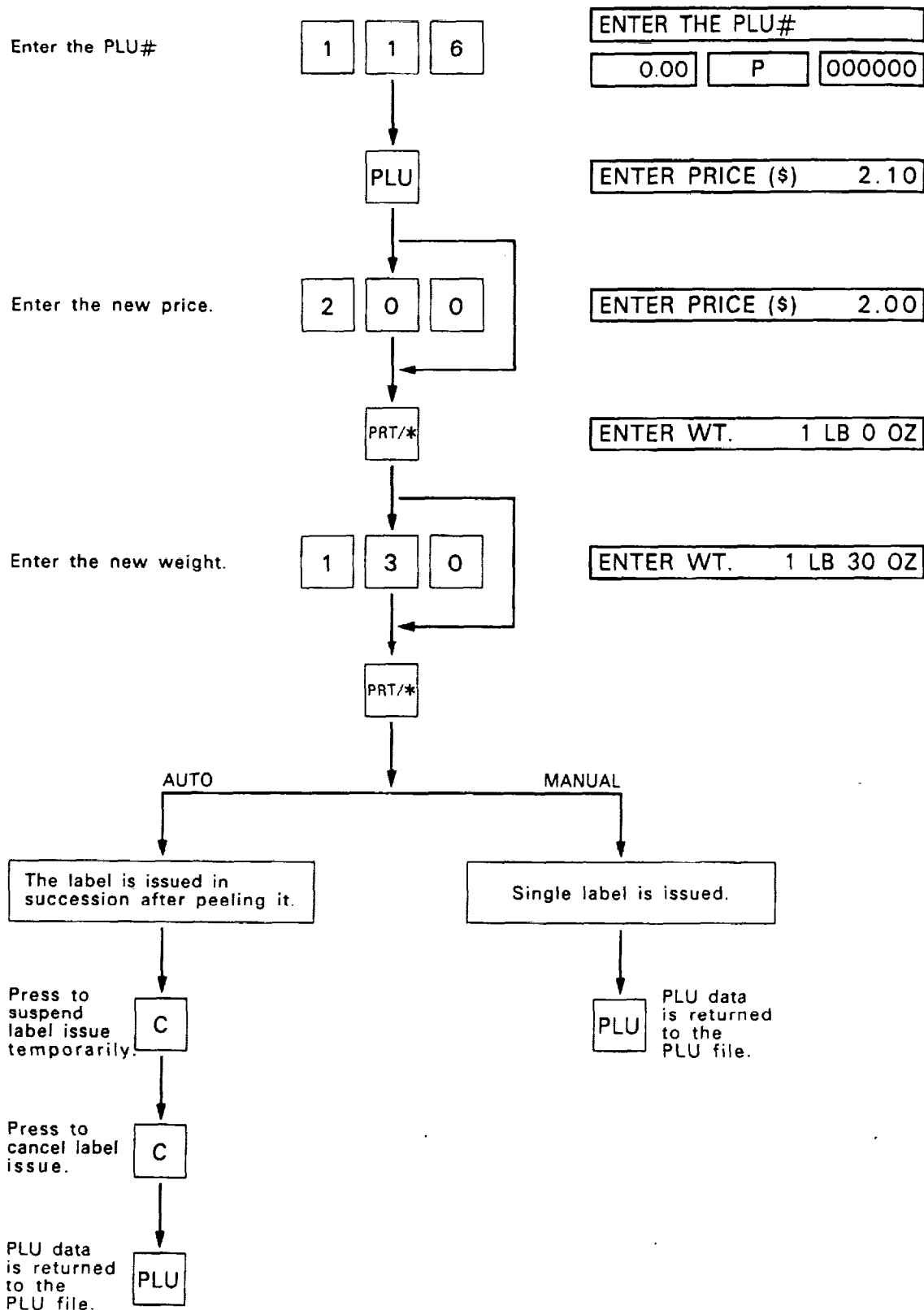

NOTE 1: With this procedure, the tare weight programmed in the PLU is displayed and printed.

Example) Tare Weight: 1 lb → NET WT. 16 OZ (1LB 00Z)
correct weight

The weight which is entered to change the tare weight is printed out as it is.

Example) Weight: 1.30 lbs → NET WT. 46 OZ (1LB 30 OZ)
correct weight: 2LB14OZ

LEMON MERINGUE PIE		
INGREDIENTS: WHEAT FLOUR=30%, MERINGUE=15%, LEMON=5%, BUTTER=10%, EGG=10%, CHEESE=5%, SUGAR=3%, SALT=2%, WATER=11%		
	PACKED ON	AUG 21
200116202002	SELL BY	AUG 25
	\$2.00	
NET WT. 4	PRICE/lb 5	TOTAL PRICE 3
NET WT. 46 OZ (1 LB 30 OZ)		
TEC BAKERY (TEL) 888-1111 4401-A BANKERS CIRCLE AT.		

(Sample label)

NOTE 2: The NET WT. label can be issued by setting initial set # 2-7 to one of "1" to "4", # 5-3 to "1" and # 7-1 to "0".

11-6. Tare Function Procedure

There are two kinds of tare subtraction procedures, one is "Direct tare", the other is "Preset tare".

1) Direct tare subtraction

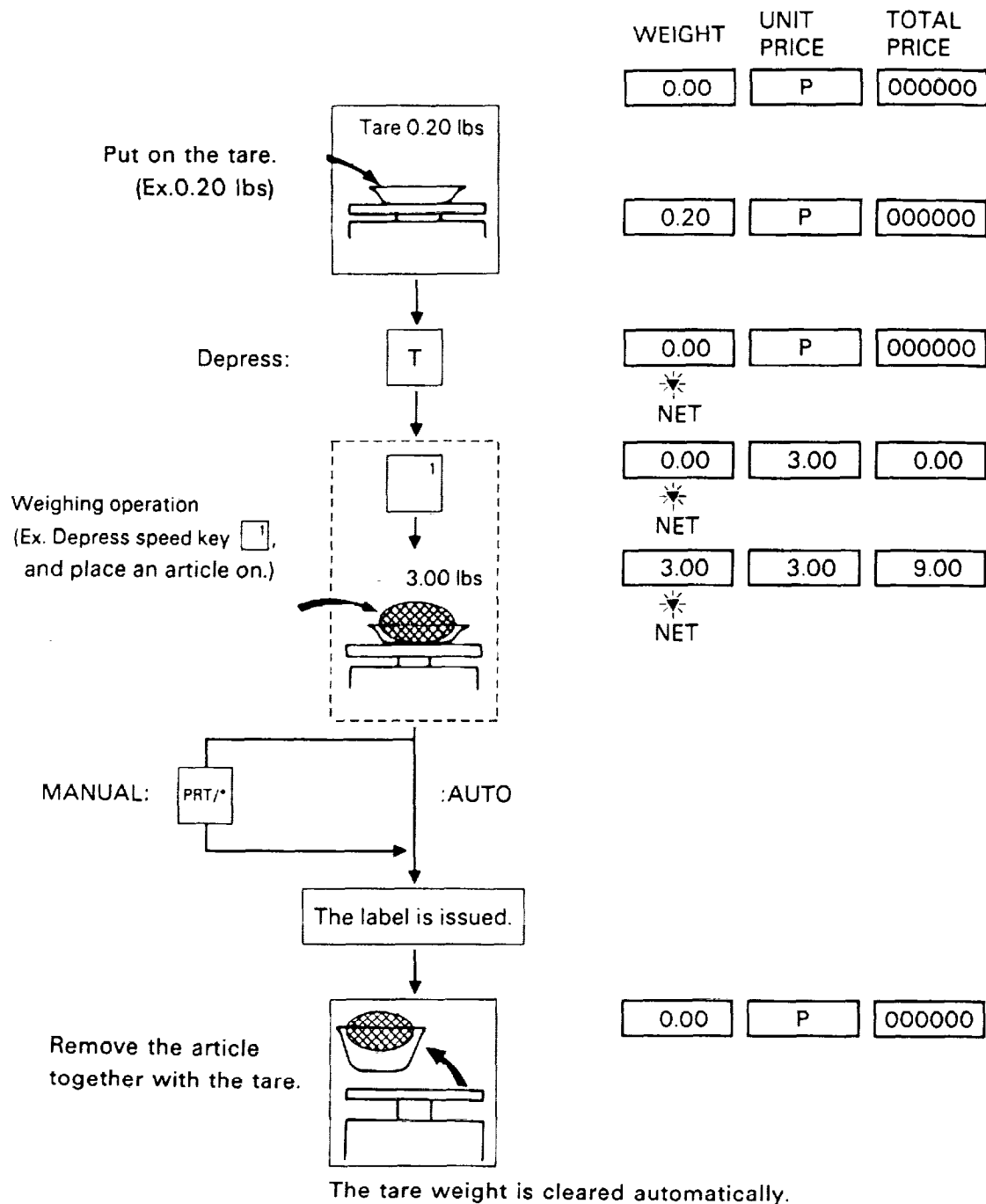

NOTE: Tare weight subtraction is available up to 30 lbs. When tare weight subtraction is in operation, however, the scalable range for net weight becomes less by the amount of the tare.
(Net weight = Gross weight - Tare weight)

2) Preset tare subtraction

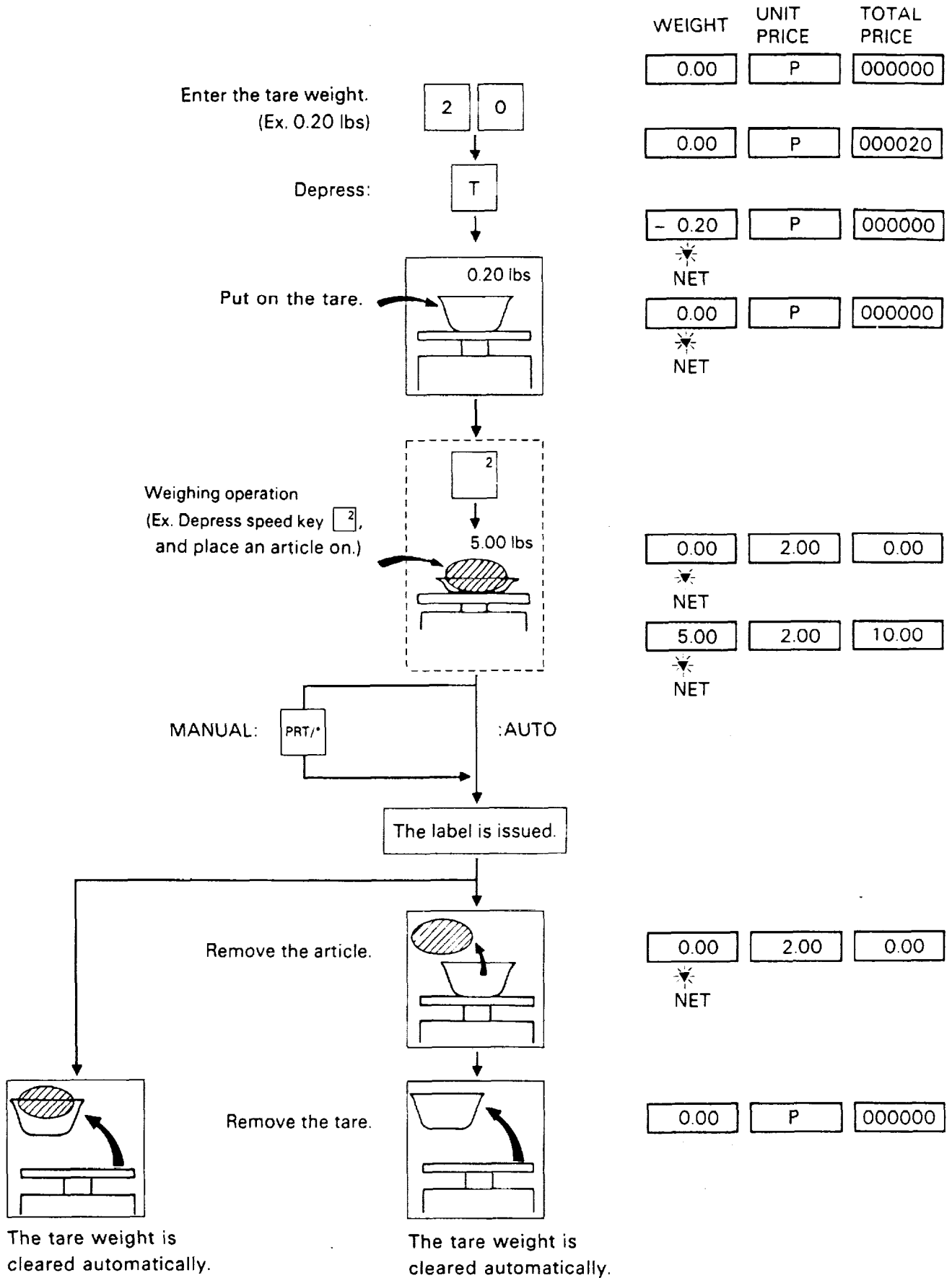

3) Preset tare subtraction (PLU including tare weight)
(only for backroom type)

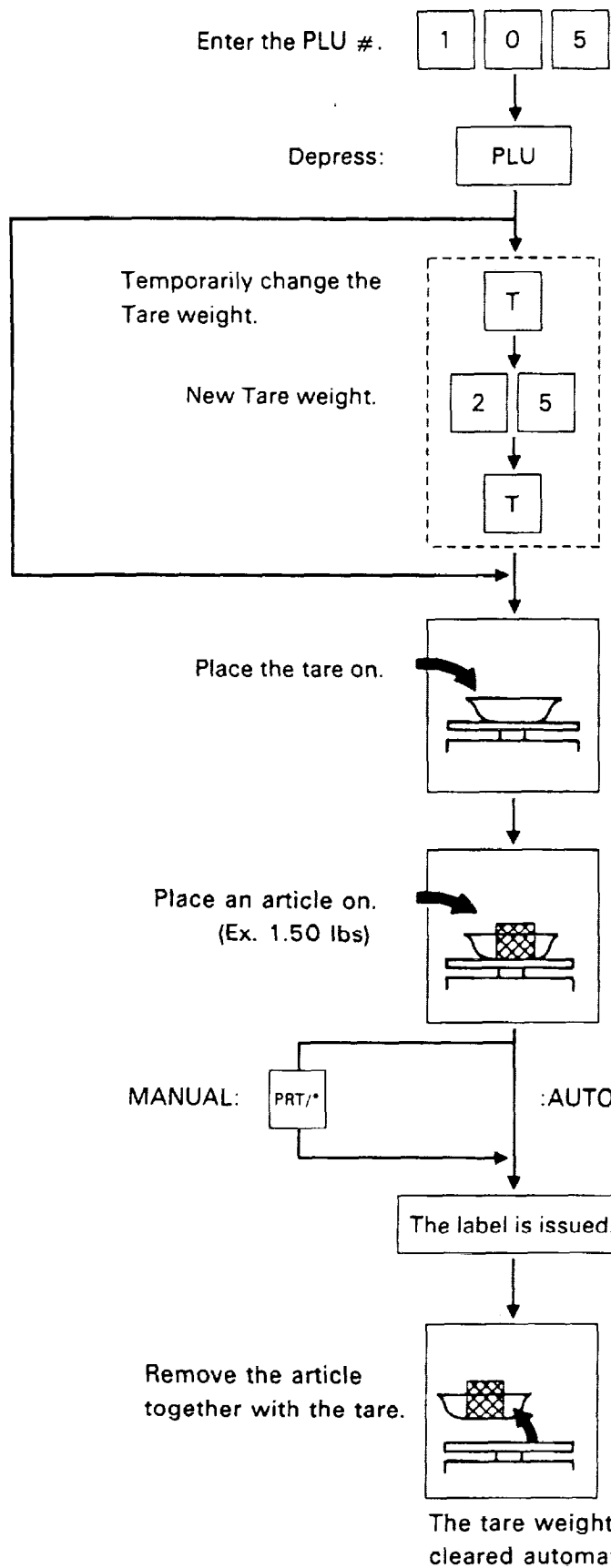

WEIGHT	UNIT PRICE	TOTAL PRICE
0.00	P	000000
- 0.50	0.80	
NET		
0.00		
0.25		
- 0.25	0.80	
NET		
0.00	0.80	0.00
NET		
1.50	0.80	1.20
NET		
- 0.50	0.80	
NET		

11-7. SAVE Key Operation Sample

The SAVE key is used to save the tare weight and unit price after taking the article off the platter.

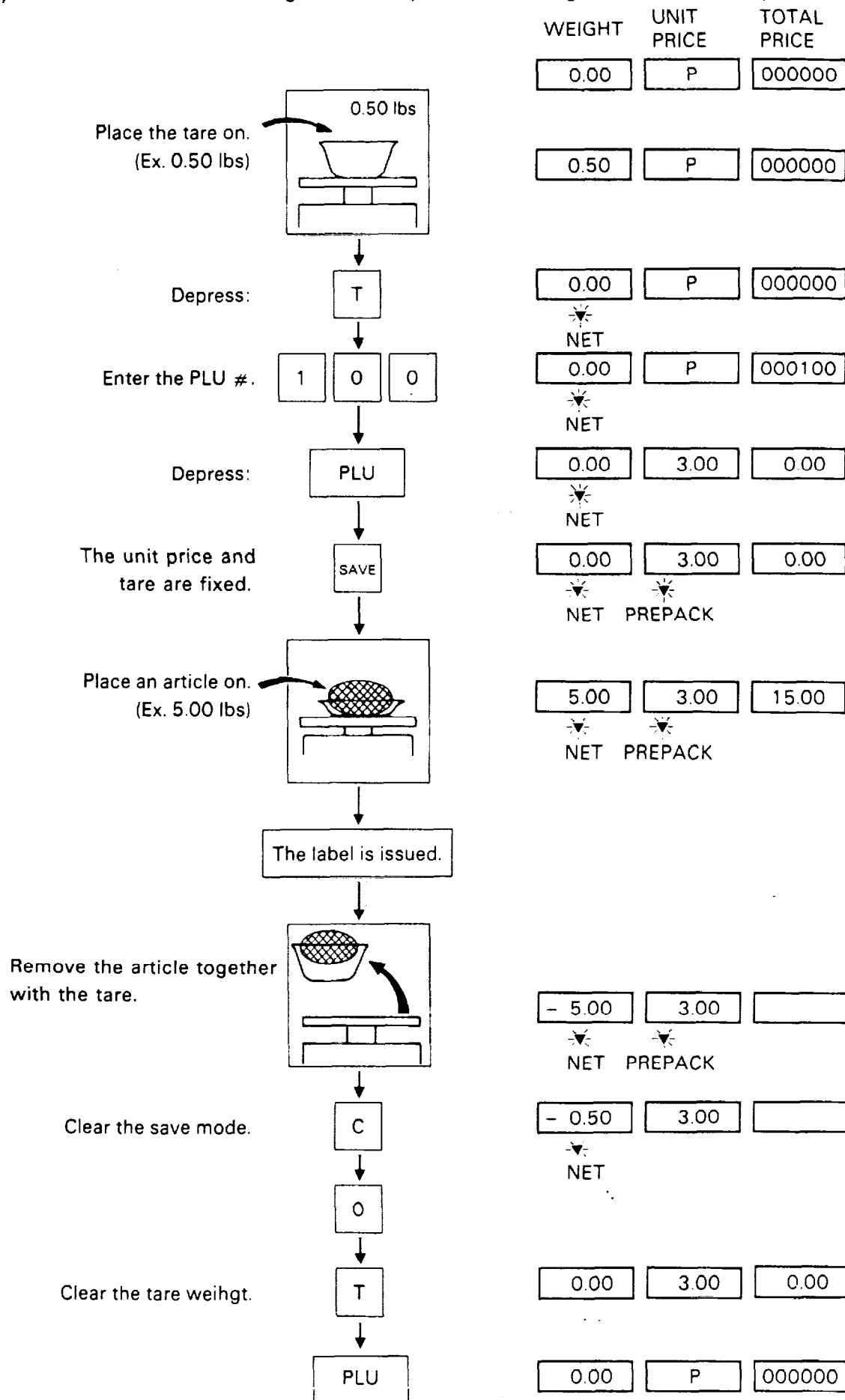

11-8. VOID Key Operation Sample

On depressing the VOID key, the data of the last registration is subtracted from the memory.

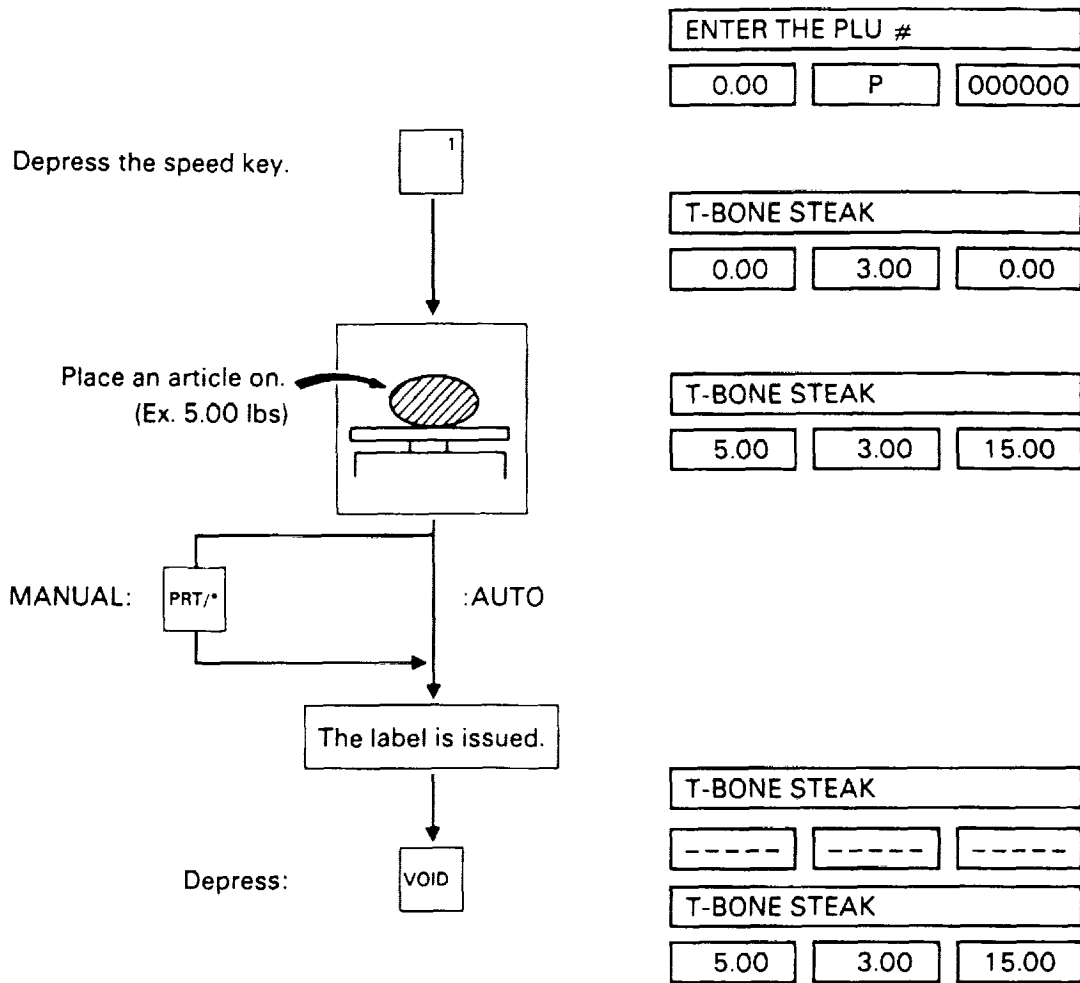

11-9. Date Change

The date can be changed temporarily.

Control lock : REG, M.DOWN, or REWRAP
 Mode SW(2) : WEIGH, BY COUNT, or FIX

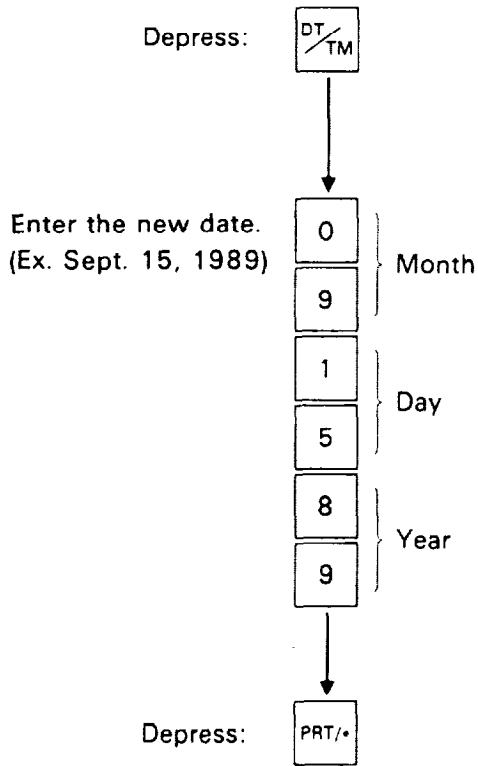

NOTE: When the original date is desired.

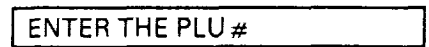
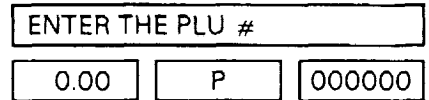
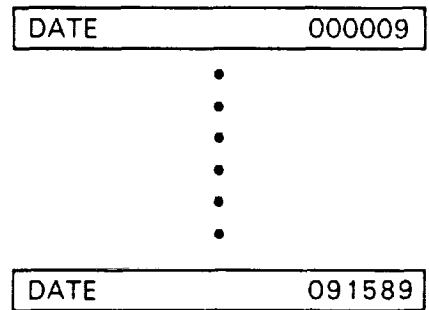
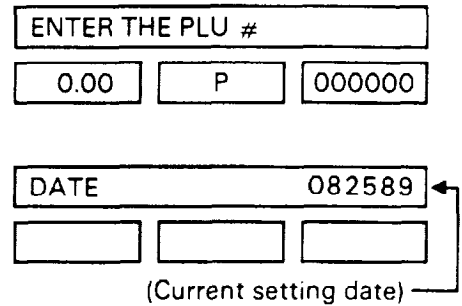
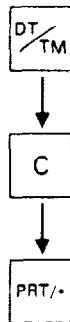

11-10. Selection of Print Item on Registered Label

This operation specifies whether each print item on the issued in registration labels is to be printed or not.

Control lock: REG, M.DOWN, or REWRAP

Mode SW(2): WEIGH, BY COUNT, or FIX

When using VARIABLE LENGTH LABEL (option), select Initial Set #4-6:0 and 2-8:4.

When using PERIOD OF RELISH (3rd DATE), select Initial Set #7-8:1.

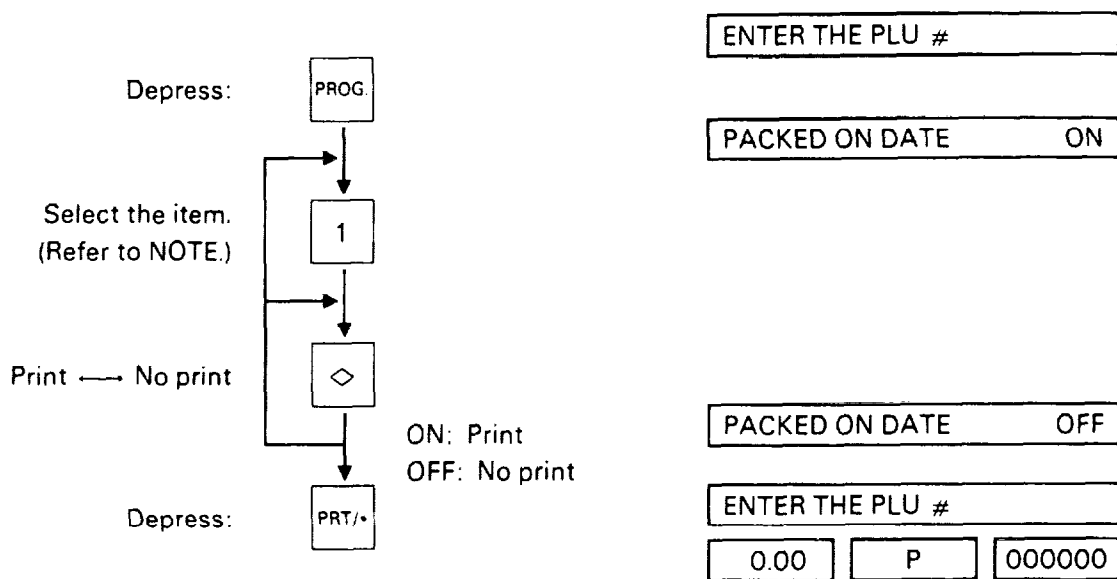

NOTE:

Entry	Item	Print/No print	Entry	Item	Print/No print
1	Packed on date	Print/No print	6	Total price	Print/No print
2	Sell by date	Print/No print	7	Bar code	Print/No print
3	Commodity name	Print/No print	8	Store code	Print/No print
4	Weight	Print/No print	9	Ingredient message	Print/No print
5	Unit price	Print/No print	10	Piece count	Print/No print
			11	Cooked by date	Print/No print

11-11. Setting Automatic Display Switching Time

When initial set #6-4 is set to "2" (standard), it is available to specify the time before a scrolling message appears automatically on the commodity name display after a label has been issued or after "ENTER THE PLU#" has been displayed.

Control lock: REG, M.DOWN, or REWRAP
 Mode SW(2): WEIGH, BY COUNT, or FIX

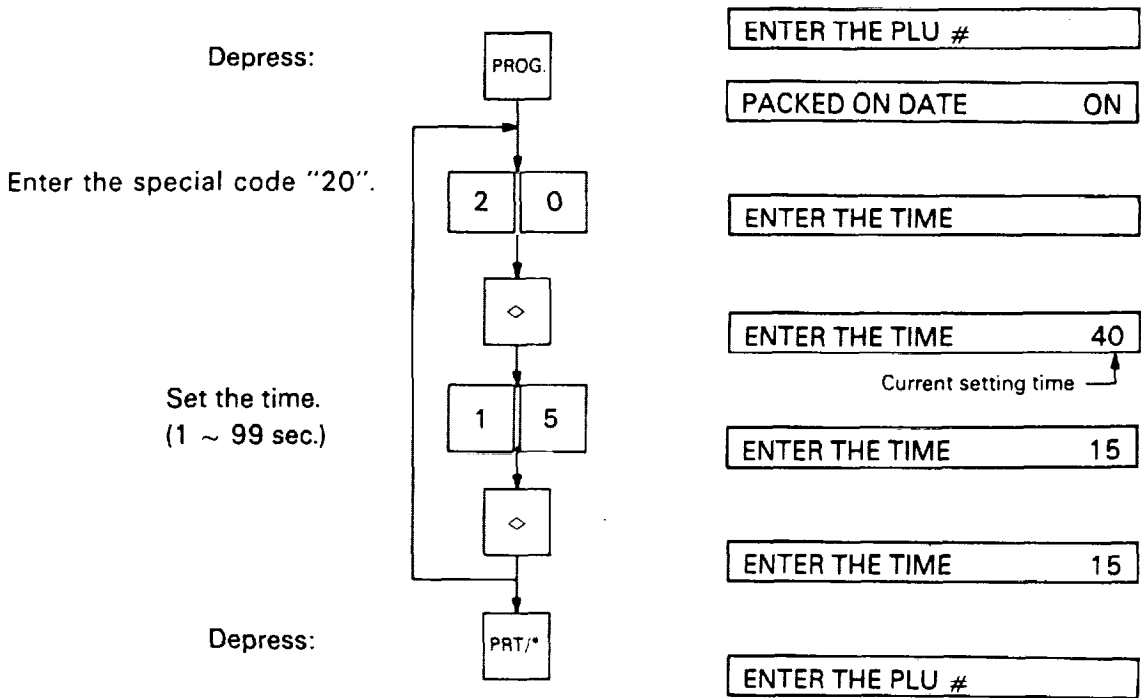

NOTE: Automatic display switching occurs provided the control lock is set to "REG", "MARK DOWN" or "REWRAP". It does not occur if the unit price has been saved.

11-12. Calling and Printing Grade Line

Control lock : REG,M.DOWN, or REWRAP
 Mode SW (2) : WEIGH, BY COUNT, or FIX

Enter the PLU#.

1 0 9

PLU

GRADE LINE

Enter the grade line#.

3

PRT/*

PRT/*

The label is issued.

ENTER THE PLU#

----- P 000000

CHEESE AND ONION BUNS

----- P 3 1.05

ENTER THE G.LINE#

CHEESE AND ONION BUNS BARGAIN SPECIAL

----- P 3 1.05

CHEESE & ONION BUNS
 BARGAIN SPECIAL

PACKED ON
 AUG 21
 SELL BY
 AUG 28

000010 000052

3 PIECES \$1.05

NET WT. (oz) PRICE/lb (¢) TOTAL PRICE (¢)

TEC BAKERY (TEL)888-1111
 4401-A BANKERS CIRCLE AT.

(Sample label)

11-13. Calling and Printing Logo

When the initial set #10-7 is set to "1" (option), the logo containing picture, mark, POP message, etc., can be printed on the ingredient label which having 12 lines or more.

Logo data is created on the PC and stored into the memory through the CMT interface.

Control lock : REG,M.DOWN, or REWRAP

Mode SW (2) : WEIGH, BY COUNT, or FIX

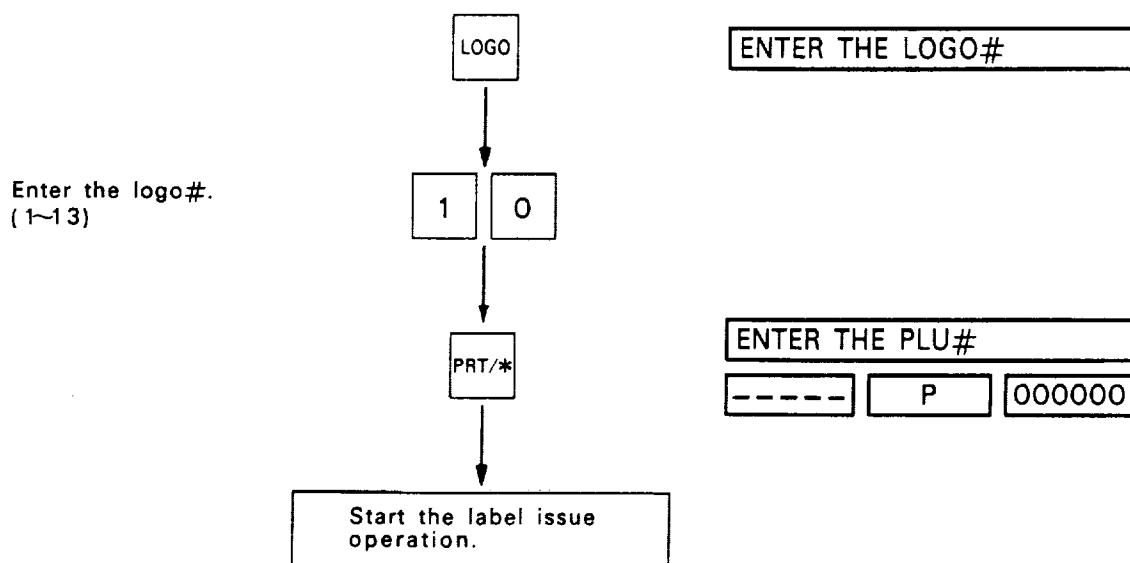

NOTE: The called logo is effective till it is canceled.

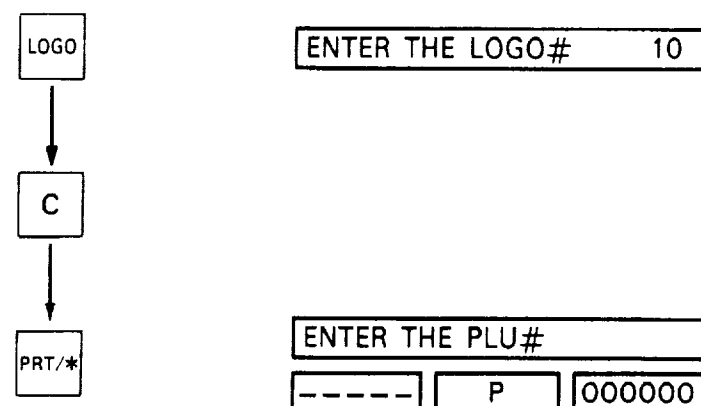

11.14 FUN Automatic Reception

Control Lock : REG, M.DOWN or REWRAP

Mode Switch (2) : WEIGH or BY COUNT

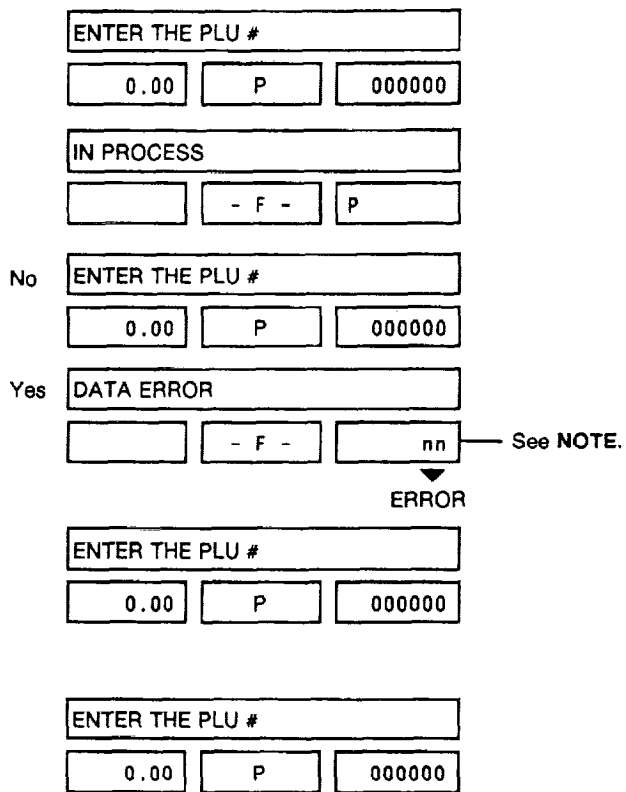
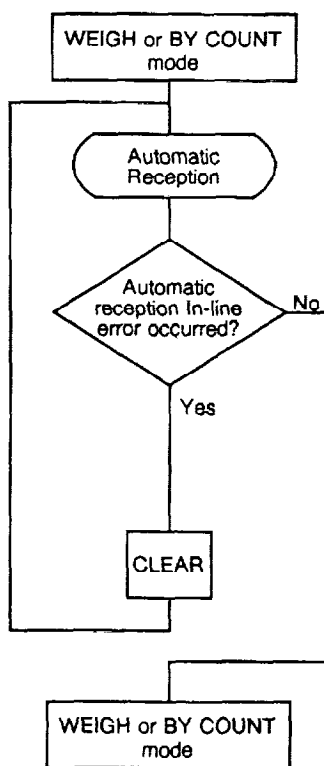

NOTES: 1.

Description		Error Description	Received Text *1								Cause	
Error Name	7-seg.		SEND				RECEIVE					
			P	U	M1	M2	P	U	M1	M2		
HARD ERROR	01	Parity error										Hard error
	02	Overrun error			○							
	04	Framing error							○			
DATA ERROR	08	Verify error			x							Compared contents do not correspond.
	10	Character over error							○			Hard error
	20	BCC error										BCC is not correct.
	40	Data error	x		○	x	x		○		x	*3
TIME OUT ERROR	80	Timeout error							○			Text with designated time has not been received.

*2

○ : Error occurs
x : No error occurs

*1 P: PLU + ING
U: UNIT PRICE
M1: MISC. 1 (ADDRESS, LOGO)
M2: MISC. 2 (SPEED KEY)

*2 When several error occur at the same time, all relevant data are added and displayed in the 7-segment display.

*3 Cause of Errors

- ① RAM for LOGO does not exist when LOGO is selected in initial set.
- ② Transmitted LOGO data exceeds the number of dots to be colored selected in the initial set.2.

2. Data is automatically received in registration mode. However, scale operation stops during reception.
3. After clearing an error, the registration initial display is shown. Data other than head data is not received.
4. When the header text is received, all contents previously set are cleared.

12. TOTAL OPERATION PROCEDURES

When the control lock is set to the "X" or "Z" position, it is available to issue READ or RESET reports. Both kinds of reports can be issued on labels or report paper.

Control lock: X or Z

"X" position: READ

The totals will not be cleared as they are printed on labels or report paper.

"Z" position: RESET

The totals will be cleared as they are printed on labels or report paper.

12-1. Hourly Report

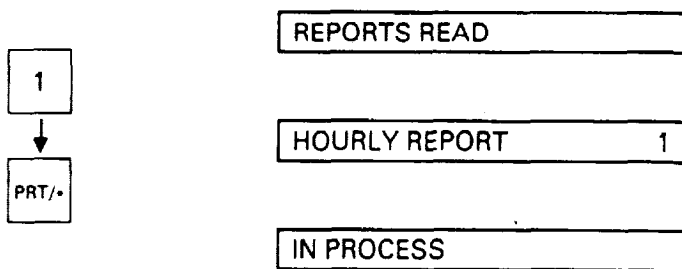

The labels of hourly report are issued consecutively.

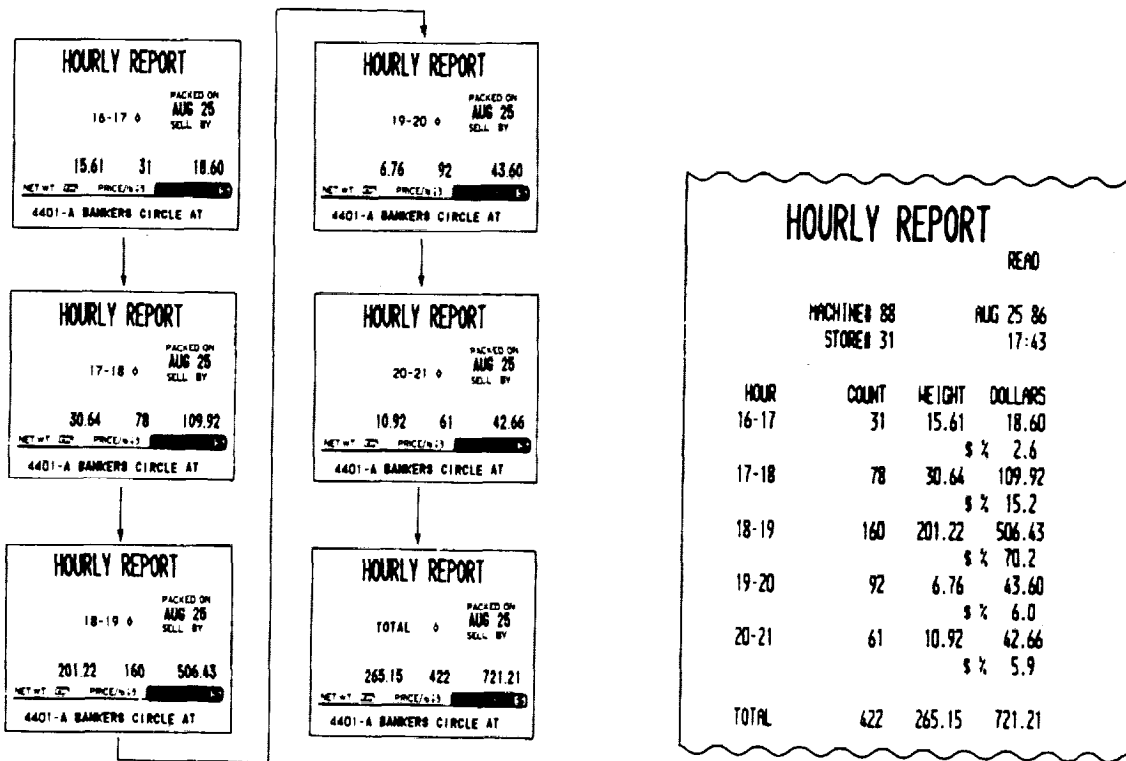

(Sample labels)

(Sample report)

12-2. Grand Total Report

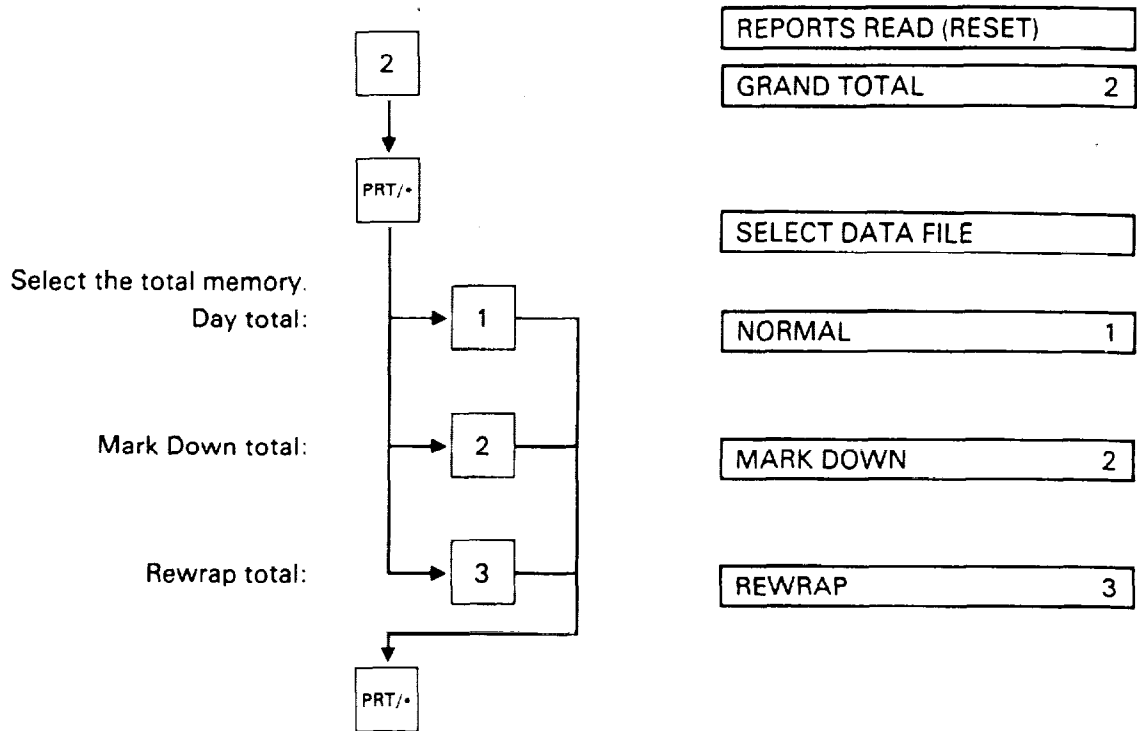

Total label including total weight, items, and amounts is issued.

Day total:

GRAND TOTAL		
	PACKED ON	AUG 25
NO	SELL BY	
282.20	567	904.92
NET WT	PRICE/lb	TOTAL PRICE
4401-A BANKERS CIRCLE AT		

(Sample label)

GRAND TOTAL			
	NORMAL	READ	
MACHINE#	88	AUG 25 86	
STORE#	31	17:43	
TOTAL	COUNT	WEIGHT	DOLLARS
	365	207.49	604.08

(Sample report)

Mark Down total:

GRAND TOTAL		
	PACKED ON	AUG 25
NO	SELL BY	
40.26	9	62.38
NET WT	PRICE/lb	TOTAL PRICE
4401-A BANKERS CIRCLE AT		

(Sample label)

GRAND TOTAL			
	MARK DOWN	READ	
MACHINE#	88	AUG 25 86	
STORE#	31	17:44	
TOTAL	COUNT	WEIGHT	DOLLARS
	9	40.26	62.38

(Sample report)

Rewrap total:

GRAND TOTAL		
	PACKED ON	AUG 25
NO	SELL BY	
17.40	48	54.75
NET WT	PRICE/lb	TOTAL PRICE
4401-A BANKERS CIRCLE AT		

(Sample label)

GRAND TOTAL			
	REWRAP	READ	
MACHINE#	88	AUG 25 86	
STORE#	31	17:44	
TOTAL	COUNT	WEIGHT	DOLLARS
	48	17.40	54.75

(Sample report)

12-3. PLU Report

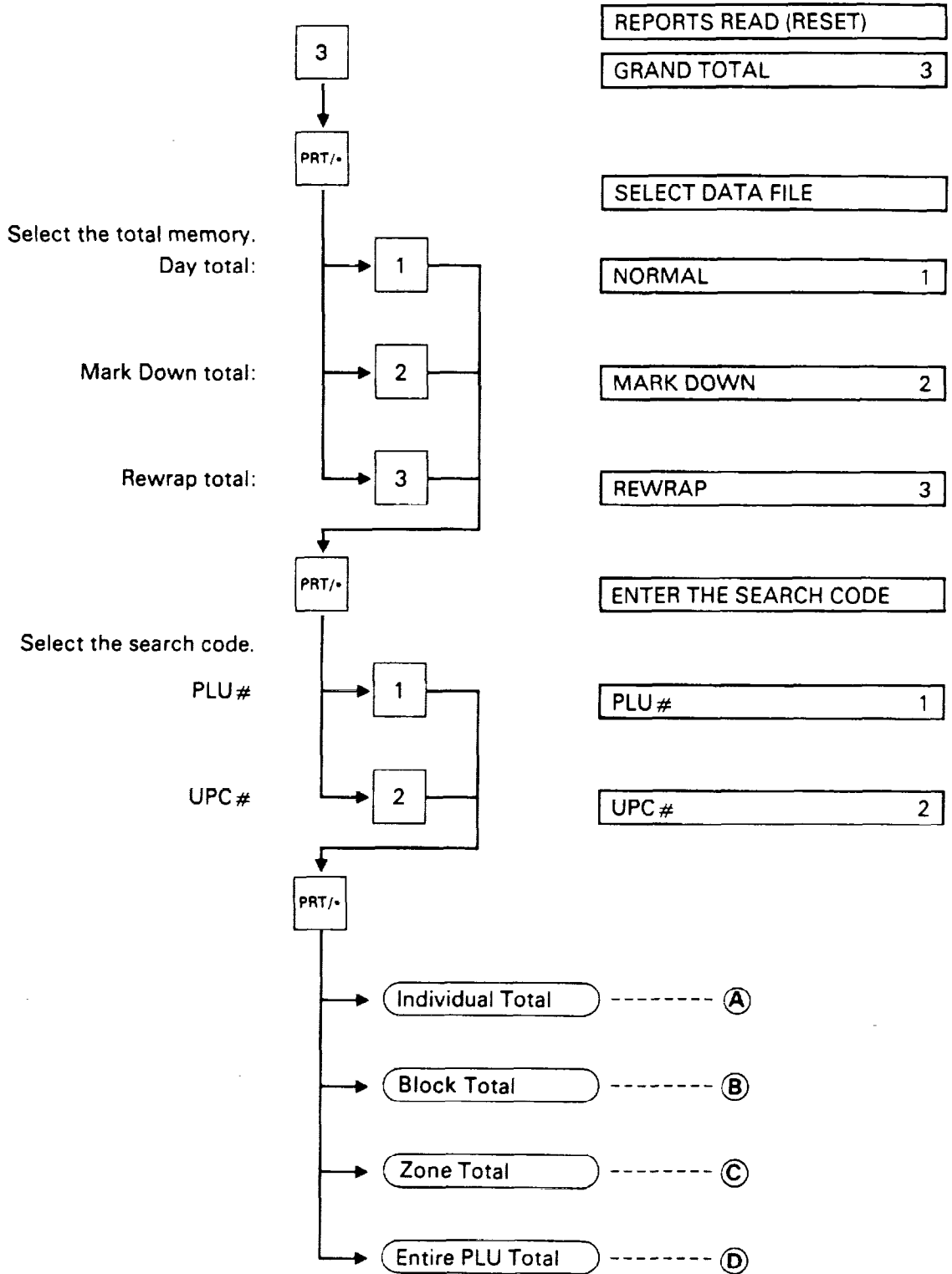

(A) Individual Total

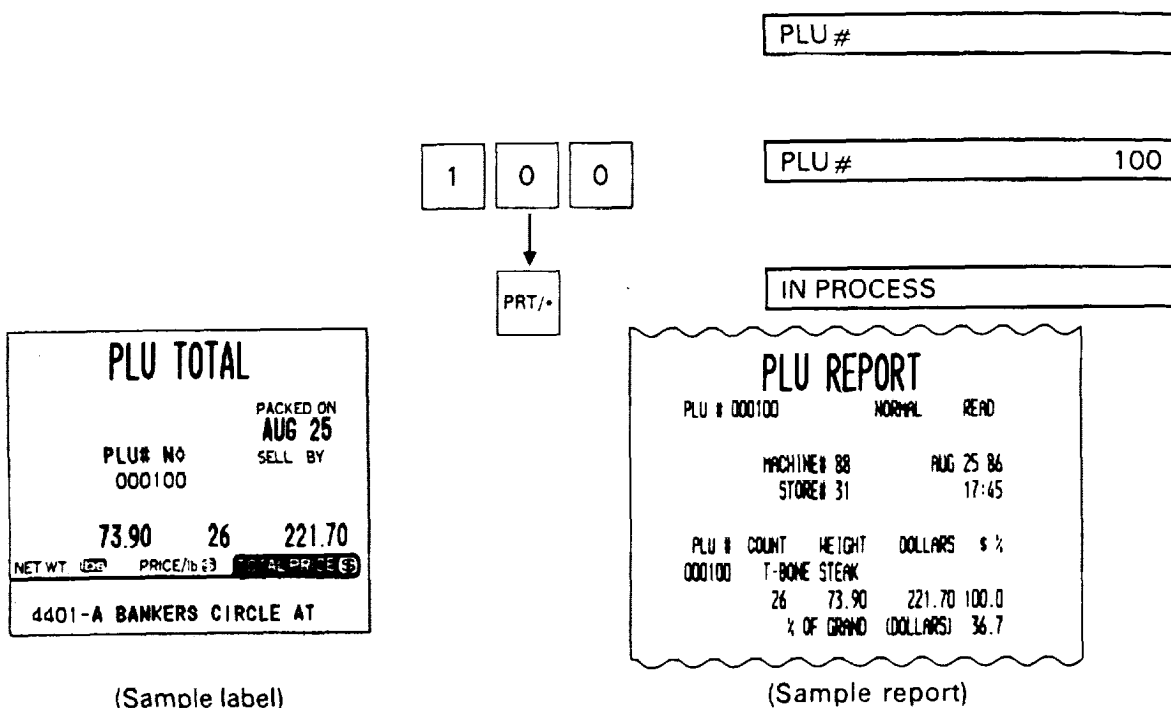

Ex.) Individual PLU Total (PLU # 100)

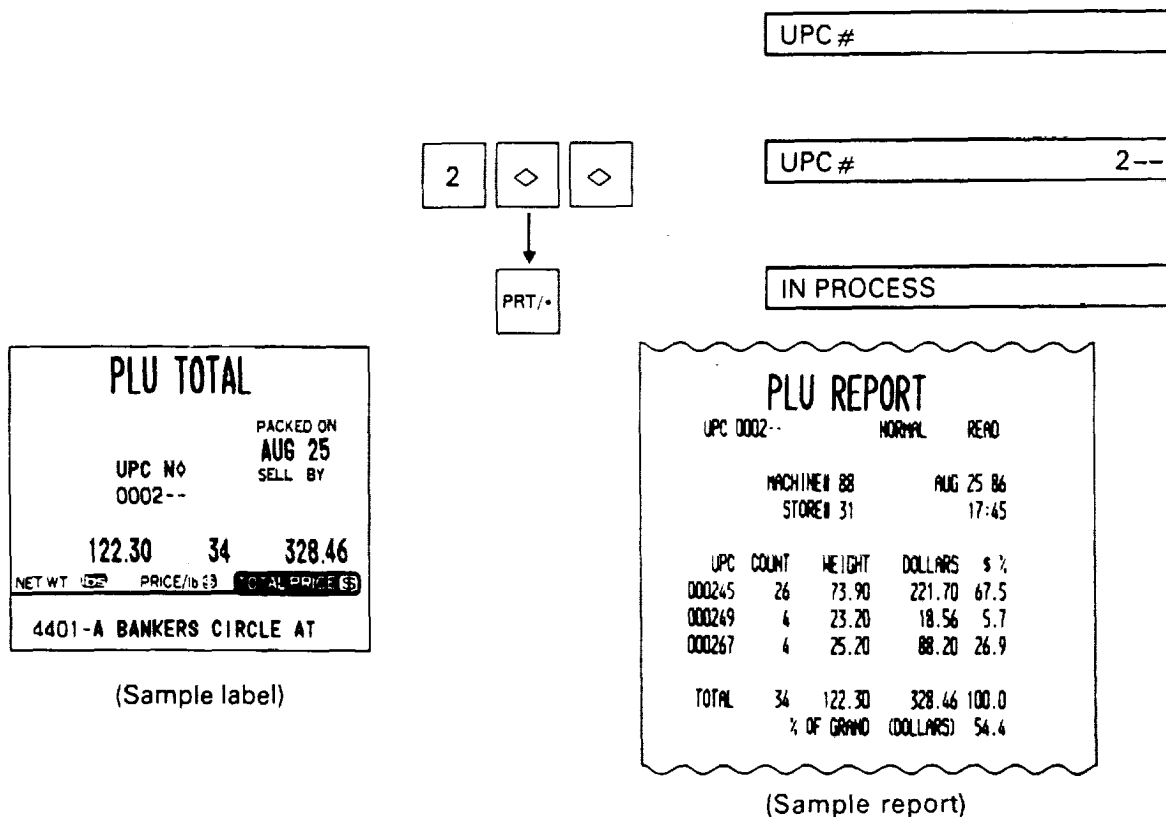

(B) Block Total

Ex.) UPC Block Total (UPC # 200 ~ 299)



NOTE: The  key represents 0 through 9. Most significant digit in starting number followed by appropriate number of the  keys.

© Zone Total

Ex.) PLU Zone Total (PLU#3001-3091)

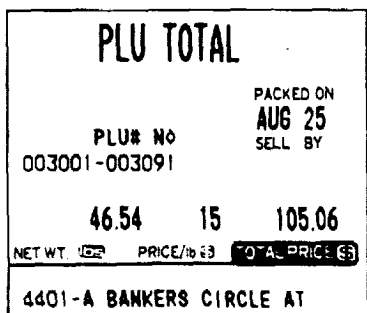
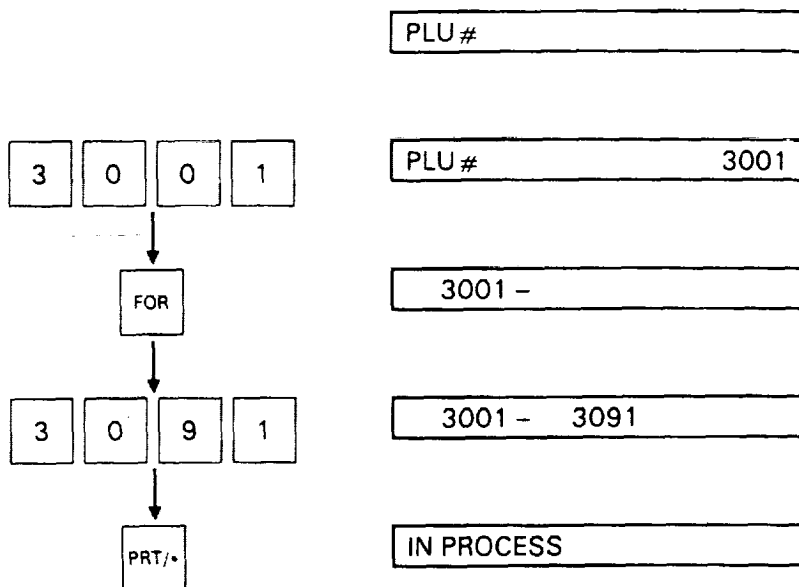

(Sample label)

PLU REPORT

PLU # 003001-003091 NORMAL READ

MACHINE# 88 AUG 25 86
STORE# 31 17:46

PLU #	COUNT	WEIGHT	DOLLARS	%
003001	COD FILETS			
	3	5.26	2.10	2.0
003036	SMOKED SALMON CHUNKS			
	4	25.20	95.76	91.1
003091	SHRIMPS			
	8	16.08	7.20	6.9
TOTAL	15	46.54	105.06	100.0
		% OF GRAND	(DOLLARS)	17.4

(Sample report)

Ⓓ Entire PLU Total

PRT/•

PLU TOTAL		
		PACKED ON AUG 25
PLU# N0		SELL BY
ALL		
200.73	362	601.68
NET WT	PRICE/lb	TOTAL PRICE
4401-A BANKERS CIRCLE AT		

(Sample label)

PLU REPORT				
PLU # ALL		NORMAL		READ
	MACHINE#	88		AUG 25 86
	STORE#	31		19:43
PLU #	COUNT	WEIGHT	DOLLARS	%
000035	CHEESECAKE			
	53	0.00	42.40	7.0
000039	BUTTER COOKIE			
	70	0.00	3.50	0.6
000052	RED DELICIOUS APPLES PRODUCE OF U.S.A.			
	66	0.00	19.50	3.2
000077	NAVEL ORANGES			
	72	0.00	36.00	6.0
000100	T-BONE STEAK			
	26	73.90	221.70	36.8
000105	BEEF LIVER			
	4	23.20	18.56	3.1
000108	SILOH STEAK			
	4	25.20	88.20	14.7
000205	PORK LOIN RIB CHOPS			
	4	25.20	45.36	7.5
000724	CHICKEN WING			
	67	0.00	18.40	3.1
000781	TURKEY DRUMSTICKS			
	3	6.69	3.00	0.5
003001	COD FILETS			
	3	5.26	2.10	0.3
003036	SMOKED SALMON CHUNKS			
	4	25.20	95.76	15.9
003091	SHRIMP			
	8	16.08	7.20	1.2
TOTAL	362	200.73	601.68	100.0
			% OF GRAND (DOLLARS)	100.0

(Sample report)

12-4. Combination Report

The total reports or setting reports are printed in the order of the specified tables (max. 8 tables).

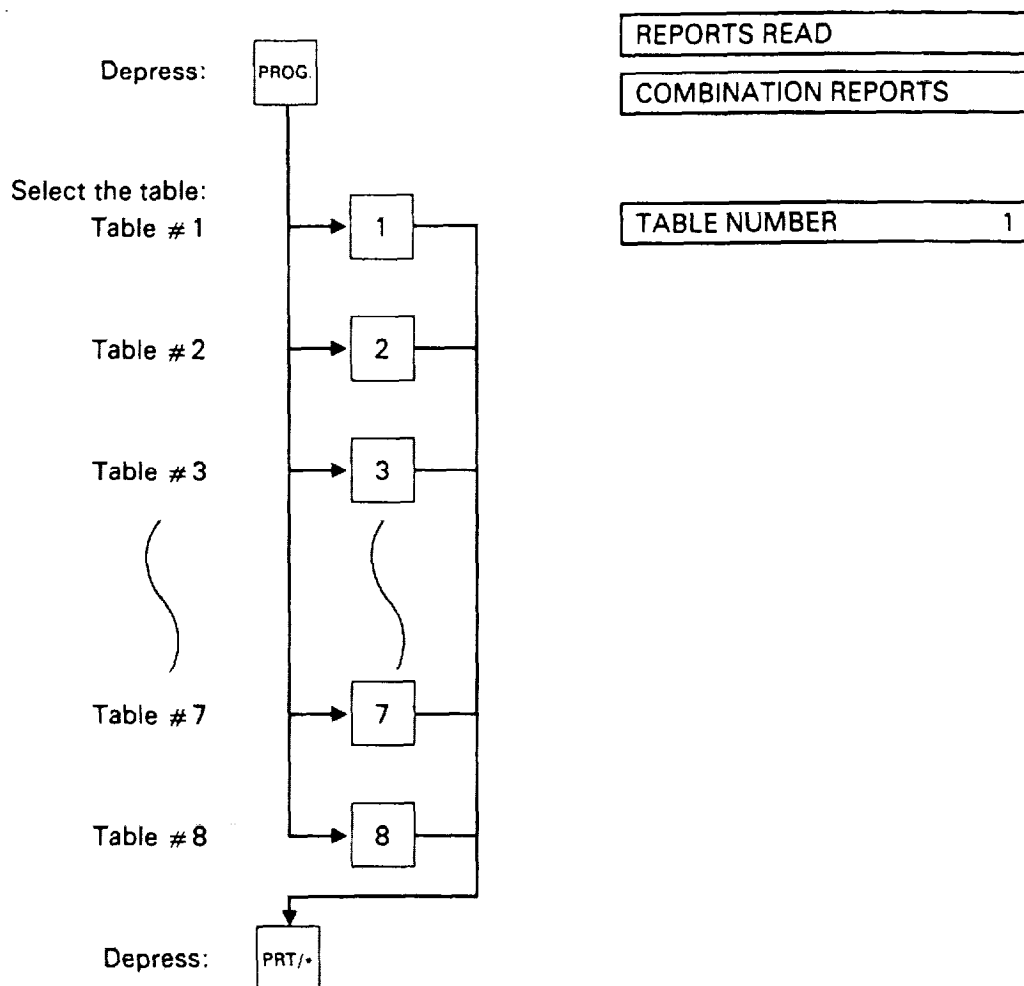

NOTE 1: If an error occurs while the combination reports are being printed, the data which is not printed out is printed as the "Canceled report" after the combination reports are printed.

NOTE2: With the control lock set to the "Z" position, only the total reports are printed out.

HOURLY REPORT

READ

MACHINE# 88 AUG 25 86
STORE# 31 17:47

HOUR	COUNT	WEIGHT	DOLLARS
16-17	31	15.61	18.60
		\$ %	2.6
17-18	78	30.64	109.92
		\$ %	15.2
18-19	160	201.22	506.43
		\$ %	70.2
19-20	92	6.76	43.60
		\$ %	6.0
20-21	61	10.92	42.66
		\$ %	5.9
TOTAL	422	265.15	721.21

GRAND TOTAL

NORMAL READ

MACHINE# 88 AUG 25 86
STORE# 31 17:47

TOTAL	COUNT	WEIGHT	DOLLARS
	365	207.49	604.08

GRAND TOTAL

MARK DOWN READ

MACHINE# 88 AUG 25 86
STORE# 31 17:47

TOTAL	COUNT	WEIGHT	DOLLARS
	9	40.26	62.38

GRAND TOTAL

REWRAP READ

MACHINE# 88 AUG 25 86
STORE# 31 17:47

TOTAL	COUNT	WEIGHT	DOLLARS
	48	17.40	54.75

PLU REPORT

PLU # ALL NORMAL READ

MACHINE# 88 AUG 25 86
STORE# 31 17:47

PLU #	COUNT	WEIGHT	DOLLARS	\$ %
000015	3	6.76	2.40	0.4
000035	53	0.00	42.40	7.0
				BITTER COOKIE

PRODUCE OF U.S.A.

000077	44	0.00	19.50	3.2
				NAVEL ORANGES
000100	72	0.00	36.00	6.0
				T-BONE STEAK
000105	26	73.90	221.70	36.7
				BEEF LIVER
000108	4	23.20	18.56	3.1
				SIRLOIN STEAK
000205	4	25.20	88.20	14.6
				PORK LOIN RIB CHOPS
000724	4	25.20	45.36	7.5
				CHICKEN WING
000781	67	0.00	18.40	3.0
				TURKEY DRUMSTICKS
003001	3	6.69	3.00	0.5
				COO FILETS
003036	3	5.26	2.10	0.3
				SMOKED SALMON CHUNKS
003091	4	25.20	95.76	15.9
				SHRIMPS
TOTAL	8	16.08	7.20	1.2
				% OF GRAND (DOLLARS) 100.0

PLU REPORT

PLU # ALL REWRAP READ

MACHINE# 88 AUG 25 86
STORE# 31 17:47

PLU #	COUNT	WEIGHT	DOLLARS	\$ %
000505	3	17.40	43.50	79.5
				LAMB SIRLOIN
000724	45	0.00	11.25	20.5
				CHICKEN WING
TOTAL	48	17.40	54.75	100.0
				% OF GRAND (DOLLARS) 100.0

PLU REPORT

UPC ALL MARK DOWN READ

MACHINE# 88 AUG 25 86
STORE# 31 17:47

UPC	COUNT	WEIGHT	DOLLARS	\$ %
000267	2	5.46	16.38	26.3
000315	1	0.00	2.50	4.0
002085	6	34.80	43.50	69.7
TOTAL	9	40.26	62.38	100.0
				% OF GRAND (DOLLARS) 100.0

(Sample report)

13. ACTION FOR ERROR MESSAGES

Take the following action if an error message appears on the commodity name display with the buzzer sounding.

● Label Issue Mode

Control lock: REG./MARK DOWN/REWRAP

Message	Cause	Solution
DATA ENTRY ERROR	Error in key input.	Depress the [C] key, and re-input.
PLU NOT FOUND	The PLU # being called out is not registered.	Depress the [C] key, and check the PLU data.
TOTALS OVERFLOW	GRAND TOTAL or PLU TOTAL memory has overflowed at the time of issuing a label.	Depress the [C] key, and turn the control lock at "Z" position. Then sum up the overflowing memory.
PLU DATA ERROR	Error of PLU data.	Depress the [C] key, and check the PLU data.
PRT FAILURE DETECTED	Printer trouble.	1. Check that the label and printer head are set correctly. 2. If the label home position is misaligned, press the [FEED] key.
CASSETTE ERROR	Label cassette is not set correctly.	Set the cassette correctly.
	Cassette switch is not set correctly.	Set the cassette switch correctly.
	Setting of control lock position and cassette switch is not correct.	When control lock position is set to other than "X" or "Z", set the cassette switch to "LABEL POSITION".
LABEL SENSE ERROR	The label interrupts the sensors.	Depress the [C] key, then the [FEED] key, and remove the label.

● Read and Reset Mode

Control lock: X (read)/Z (reset)

Message	Cause	Solution
PLU NOT FOUND	Corresponding PLU# or UPC is not registered.	Depress the C key, and enter the correct PLU#.
NO REGISTERED REPORTS	There is no combination report setting data.	Depress the C key, and check the combination report tables.
PRT FAILURE DETECTED	Printer trouble	Same as in the label issue mode.
CASSETTE ERROR	Label cassette is not set correctly.	Set the cassette correctly.
LABEL SENSE ERROR	The label interrupts the sensors.	Depress the C key, then the FEED key, and remove the label.

14. LABEL PRINT FORMATS

1) Weighing Label

Labels with arrows pointing to the label content:

- Commodity Name: T-BONE STEAK
- Packed on date: AUG 25
- Sell by date: AUG 30
- Total Price: \$15.00
- Store Address: 4401-A BANKERS CIRCLE AT
- Unit price: 5.00
- Weight: 3.00

2) By Count Label

Labels with arrows pointing to the label content:

- Commodity Name: RED DELICIOUS APPLES
- Commodity Name: PRODUCE OF U.S.A.
- Total Price: \$1.50
- Store Address: 4401-A BANKERS CIRCLE AT
- Number of articles: 5 PIECES

3) Fix Price Label

Labels with arrows pointing to the label content:

- Total Price: \$3.80
- Weight: 2.00
- Store Address: 4401-A BANKERS CIRCLE AT

4) Ingredient and Period of Relish Label

BUTTER COOKIE ← Commodity Name

COOKED BY DEC 1 ← Period of Relish

INGREDIENTS-USING A FLOUR OF BEST QUALITY ← Ingredient Message

WHEAT FLOUR ... 4 OZ
 BUTTER 4 OZ
 SUGAR 1 OZ
 COCOA 1 OZ
 SALT 0.5 OZ
 EGG 1.5 OZ
 ALMOND 2 OZ
 WATER 2 OZ

PERCENTAGE OF U.S. R. D. A.
 PROTEIN = 7 1/2 FAT = 10%
 VITAMIN A = 62 VITAMIN C = 4%
 VITAMIN B1 = 72 SODIUM = 2%

PACKED ON NOV 21 SELL BY NOV 28

1 PIECES **\$2.25** ← Price
 TOTAL PRICE



000072 000014

4401-1A BANKERS CIRCLE AT ← Store Address

5) Net Weight Label

CHOCOLATE MERINGUE PIE ← Commodity Name

INGREDIENTS: FILLING: WATER, SUGAR, COCOA, CHOCOLATE LIQUOR, TAP ICHCA STARCH, VEGETABLE SHORTENING (WHICH CONTAINS PARTIALLY HYDROGENATED SOYBEAN OIL AND PARTIALLY HYDROGENATED COTTONSEED OIL), SALT, LOCUST BEAN GUM, TITANIUM DIOXIDE, IMITATION FLAVOR, FOOD ACID AND 1/10 OF 1% POTASSIUM SORBATE AS A PRESERVATIVE. ← Ingredient Message

MERINGUE: STARCHES, GRANULATED SUGAR, WATER, EGG ALBUMEN, SUCROSSE, VEGETABLE GUMS AND FOOD ACIDS.

CRUST: ENRICHED FLOUR (WHEAT FLOUR, NIACIN, REDUCED IRON, THIAMINE, MONONITRATE, RIBOFLAVIN), VEGETABLE SHORTENING (PARTIALLY HYDROGENATED SOYBEAN OIL), WATER, SALT, DEXTROSE, CALCIUM PROPIONATE AS A PRESERVATIVE



210030 803001

AUG 27
PACKED ON
AUG 30
SELL BY

\$3.00 ← Price

NET WT (E3) PRICE/1b (E3) TOTAL PRICE (E3)

NET WT. 58 OZ(3LB 10OZ) ← Net Weight

4401-A BANKERS CIRCLE AT

6) Bar Code Change Label

CHEESECAKE ← Commodity Name

INGREDIENTS: WHEAT FLOUR=3 OZ, BUTTER=3 OZ,
SUGAR=2 OZ, CHEESE=5 OZ, SALT=0.5 OZ, EGGS=1 OZ,
WATER=1.5 OZ
PERCENTAGE OF U.S. R.D.A.
PROTEIN=65Z, FAT=10Z, VITAMIN A=5Z, VITAMIN B1=
10Z, SODIUM=10Z.

PACKAGED NOV 29 SELL BY DEC 2

\$1.00 ← Price

NET WT. PRICE/lb **PRICE \$**

NET WT. 36OZ(1 LB 20OZ) ← Net Weight

 ← Bar Code
200721 601009

4401-A BANKERS CIRCLE ← Store Address

7) Read & Reset Mode

● Hourly report

"READ" mark (* : RESET)

17-18 ◊

PACKED ON
AUG 25
SELL BY

Total Items

Total Weight → 30.64 78 109.92 → Total Amounts

NET WT 1.00 PRICE/lb €3 TOTAL PRICE €3

4401-A BANKERS CIRCLE AT

HOURLY REPORT

TOTAL ◊

PACKED ON
AUG 25
SELL BY

265.15 422 721.21

NET WT 1.00 PRICE/lb €3 TOTAL PRICE €3

4401-A BANKERS CIRCLE AT

● Grand total report

Total Memory mark (N: Day Total, M: Mark Down Total, R: Rewrap Total)

N◊

PACKED ON
AUG 25
SELL BY

282.20 567 904.92

NET WT 1.00 PRICE/lb €3 TOTAL PRICE €3

4401-A BANKERS CIRCLE AT

● PLU total report

Individual PLU Total

Search code

PLU # 100

PLU# N◊

000100

PACKED ON
AUG 25
SELL BY

73.90 26 221.70

NET WT 1.00 PRICE/lb €3 TOTAL PRICE €3

4401-A BANKERS CIRCLE AT

Block Total

Search code

Block # 200 ~ 299

UPC N◊

0002--

PACKED ON
AUG 25
SELL BY

122.30 34 328.46

NET WT 1.00 PRICE/lb €3 TOTAL PRICE €3

4401-A BANKERS CIRCLE AT

Zone Total

Zone # 3001 ~ 3091

PLU# N◊

003001-003091

PACKED ON
AUG 25
SELL BY

46.54 15 105.06

NET WT 1.00 PRICE/lb €3 TOTAL PRICE €3

4401-A BANKERS CIRCLE AT

Entire PLU Total

PLU# N◊

ALL

PACKED ON
AUG 25
SELL BY

200.73 362 601.68

NET WT 1.00 PRICE/lb €3 TOTAL PRICE €3

4401-A BANKERS CIRCLE AT

15. BEFORE YOU CALL FOR SERVICE

It is our primary concern to give you full satisfaction and better service. If, however, any problem arises in connection with the operation of this scale, please check the following points before calling for service.

- A) Is the power plug fully plugged into an AC outlet?
- B) Is the power switch turned ON ?
- C) Is AC power being properly supplied to the outlet? (Check it using another electric appliance.)
- D) Check the circuit breaker.
- E) Has there been a power failure of any sort ?
- F) Has the operation been carried out in the correct order ?

This scale has been manufactured under strict quality control. If you have any trouble, however, **DO NOT ATTEMPT TO FIX IT BY YOURSELF**. Pull the power plug out of the AC outlet, and contact your TEC representative.

NOTE: The specifications are subject to change without notice.

16. APPENDIX

SL66 Series Bilingual Specification

EM1-31055

US type: Owner's Manual at page 32

NOTE: The print position of the grade line is selectable by setting the Initial #3-6.

No. of lines for commodity name	#3-6	Print position of the grade line
1 line (No print in the 2nd, 3rd and 4th line.)	1	<ul style="list-style-type: none"> • A grade line is printed in the 1st line. (Left-justification) • A commodity name is printed from the 2nd line.
2 lines (No print in the 3rd and 4th line.)	0	<ul style="list-style-type: none"> • A commodity name is printed from the 1st to the 3rd line. • A grade line is printed in the 4th line. (Right-justification)
3 lines (No print in the 4th line.)		
4 lines	1	<ul style="list-style-type: none"> • A grade line is printed in the 1st line. (Left-justification) • A commodity name is printed from the 2nd line to the 5th line, provided that the total number of lines of the grade line + commodity name + lng. line does not exceed the max. line of the label when using the lng. label.
	0	<ul style="list-style-type: none"> • A commodity name is printed from the 1st line to the 4th line. • A grade line is printed in the 4th line, provided that the total number of characters of commodity name + grade line does not exceed 26 characters. (Right-justification)



TEC
TOSHIBA TEC CORPORATION

 PRINTED IN JAPAN

Free Manuals Download Website

<http://myh66.com>

<http://usermanuals.us>

<http://www.somanuals.com>

<http://www.4manuals.cc>

<http://www.manual-lib.com>

<http://www.404manual.com>

<http://www.luxmanual.com>

<http://aubethermostatmanual.com>

Golf course search by state

<http://golfingnear.com>

Email search by domain

<http://emailbydomain.com>

Auto manuals search

<http://auto.somanuals.com>

TV manuals search

<http://tv.somanuals.com>