

Section I — Installation Preparation

Part Number : 86270-33090

Section I — Installation Preparation

Kit Contents

Item #	Quantity Req'd.	Description
1	1	Changer unit
2	1	Front bracket
3	1	Rear bracket
4	1	Hardware bag
5	1	CD magazine
6	1	Owner's manual

Hardware Bag Contents

Item #	Quantity Req'd.	Description
1	4	Bolts (M5×8)
2	2	Bolts (M8×16)
3	2	Bolts (M6×14)
4	4	Screws (M5×14)

Additional Items Required For Installation

Item #	Quantity Req'd.	Description
--------	-----------------	-------------

Conflicts

Note : None

Recommended Tools

Safety Tools	
None	
Special Tools	
None	
Installation Tools	
Hexagon socket	10mm
Hexagon socket	12mm
Wrench	
Trque Wrench	Inch · pound or N · m
Nylon panel removal tool	
Philips head (+) screwdriver	
Universal joint wrench	12mm
Special Chemicals	
None	

Color Applicability/Trim Level

Accessory Color	Vehicle/Trim Color											
		*										
		*										
			*									
				*								
					*							
						*						
							*					
								*				
									*			
										*		

General Applicability





Note : None

Recommended Sequence of Application

Item #	Accessory	Description
1	Changer box	58901-33010
2		
3		

Legend

* Mandatory

	STOP : Damage to the vehicle may occur. Do not proceed until process has been complied with.
	OPERATOR SAFETY : Use caution to avoid risk of injury.
	CRITICAL PROCESS : Proceed with caution to ensure a quality installation. Thees points will be audited on a completed vehicle installation.
	GENERAL PROCESS : This highlights specific processes to ensure a quality installation. These points will be audited during the accessory installation.
	TOOLS & EQUIPMENT : This calls out the specific tools and equipment required for this process.

A. Vehicle Disassembly

➔ 1. Remove the negative battery cable. (Fig. A1)

STOP i . Protect the fender before starting.

⊕ ii . Be careful to not touch the positive terminal.

➔ 2. Remove the shift lever panel, then the front console's upper panel. (Fig. A2)

STOP i . Place a protective cover over the seats and the instrumental panel before starting this procedure.

STOP ii . Remove the panels while being careful not to scratch them.

iii . Remove the wiring connectors.

➔ 3. Remove the rear console box. (Fig. A3)

i . Remove the two screws.

ii . Remove the mat, then remove the two bolts.

STOP iii . Remove the console box while being careful not to scratch it.

iv . Remove the wiring connectors.

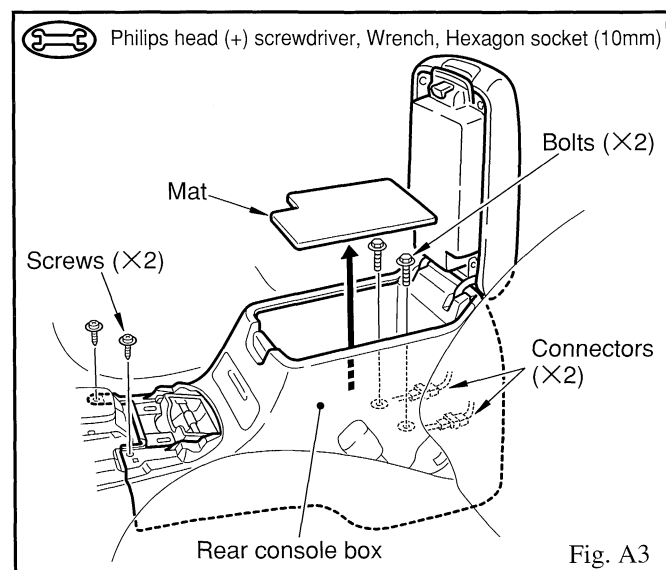
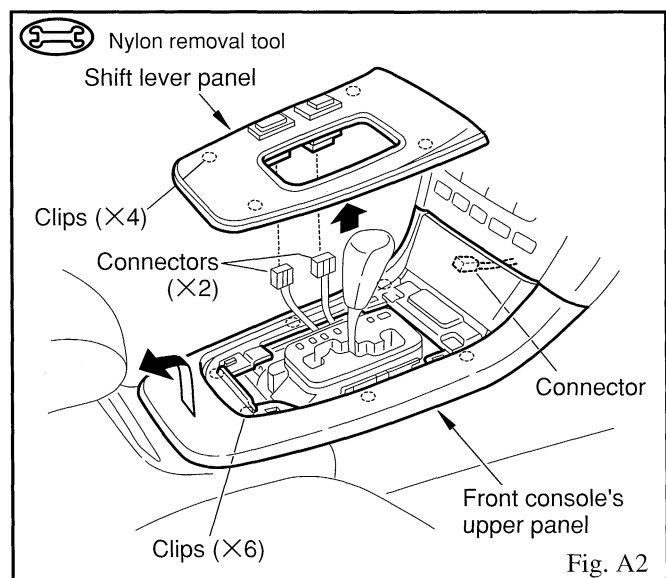
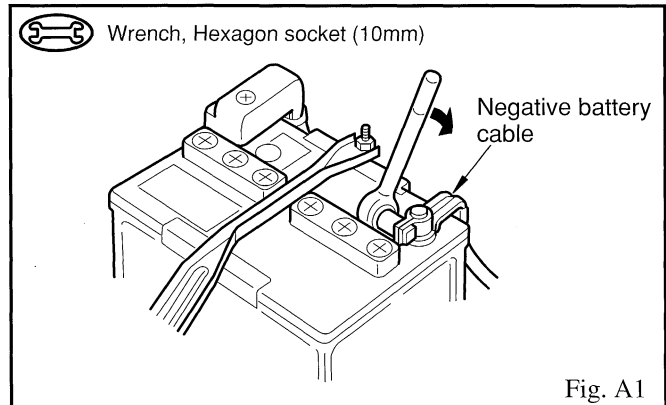

Section II — Installation Procedure

➔ 4. Remove various parts and components from the rear console box.



- Remove the console box, being careful not to scratch it.



- Please be careful not to lose any parts or components, as everything, except for the inner box, will be reused.

- i . Remove the heater duct panel. (Fig. A4)
- ii . Remove the four screws, then remove the lid. (Fig. A4)
- iii . Remove the four screws, then remove the drink holder. (Fig. A5)

IV. Remove the six screws, then remove the inner box and heater ducts (L and R). (Fig. A6)

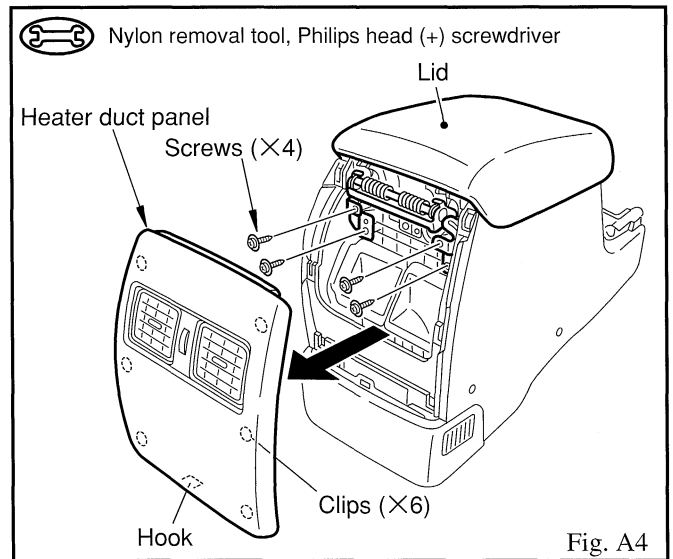

Fig. A4

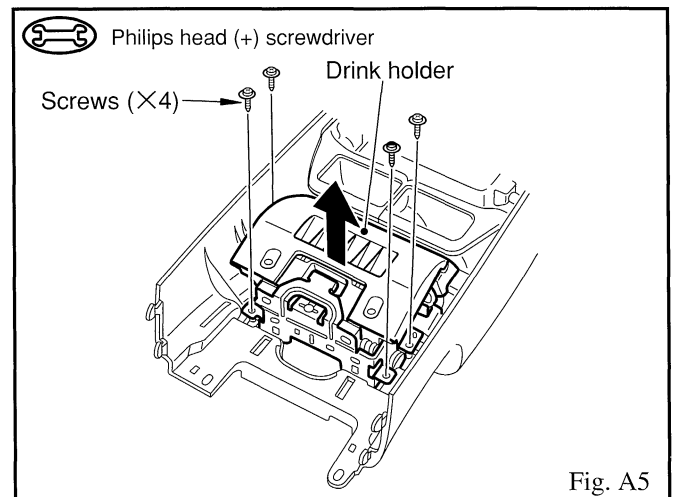

Fig. A5

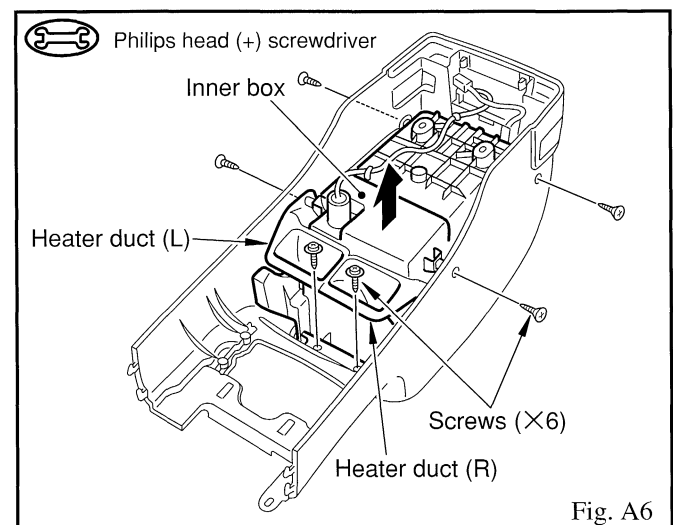

Fig. A6

➔ 5. Remove the parts and components off the inner box.

- i . Remove the four screws, then the heater ducts (L and R). (Fig. A7)
- ii . Remove the plug of the accessory power socket. (Fig. A7)



- Since the clamp will not be used, remove it from the cord.

iii . Pull the lock lever of the sleeve, and push out the accessory power socket. (Fig. A8)

iv . Remove the sleeve by pressing on the hook. (Fig. A9)

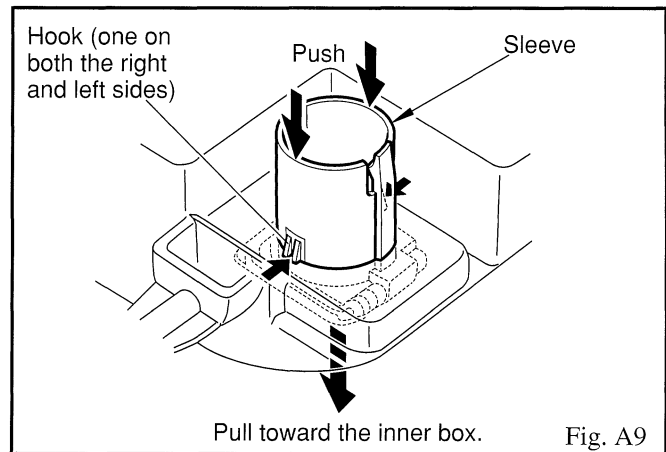
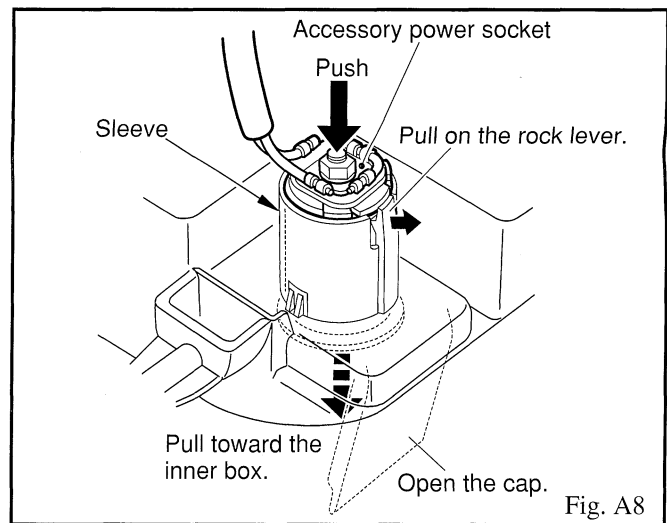
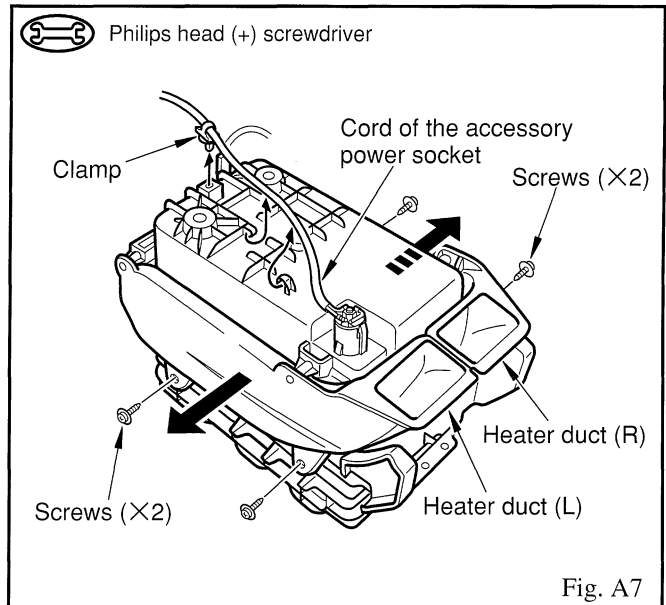

B-1. Installing the changer unit**(With a vehicle equipped with a yaw rate sensor)**

- ➔ 1. Install the brackets on the CD changer unit. (Fig. B1)



- Install the CD changer unit while being careful not to scratch it.
- i . Insert the clamp of the cord onto the front bracket.
- ii . Install the front bracket onto the CD changer unit.
- iii. Install the rear bracket onto the CD changer unit.

- ➔ 2. Install the CD changer unit on the floor.



- i . Remove the installation bolt (L) on the yaw rate sensor bracket, while loosening the installation bolt (R). (Fig. B2)
- Do not give impact on to the yaw rate sensor. If the yaw rate sensor is hit by tools and damaged, replace the yaw rate sensor with a new one and take necessary calibration process.

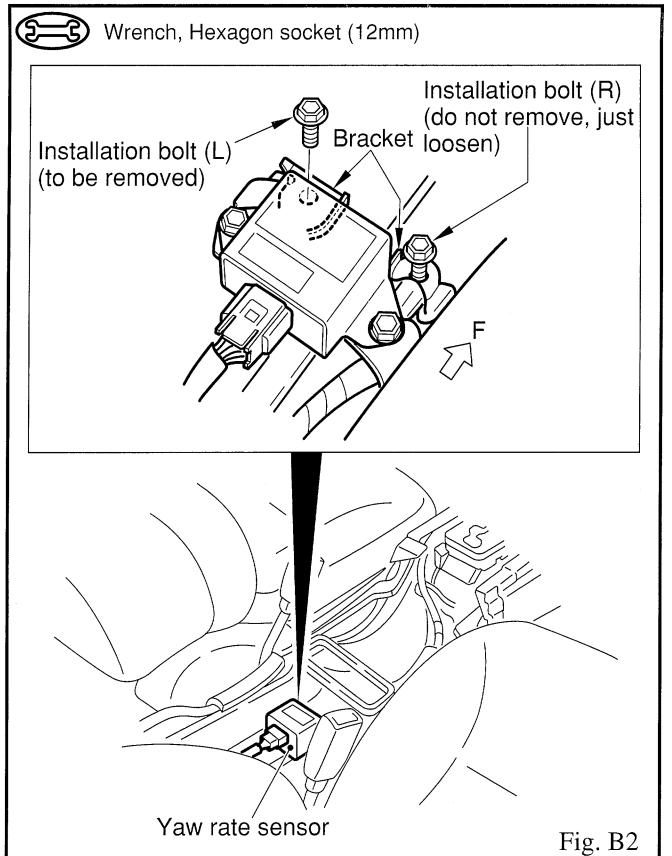
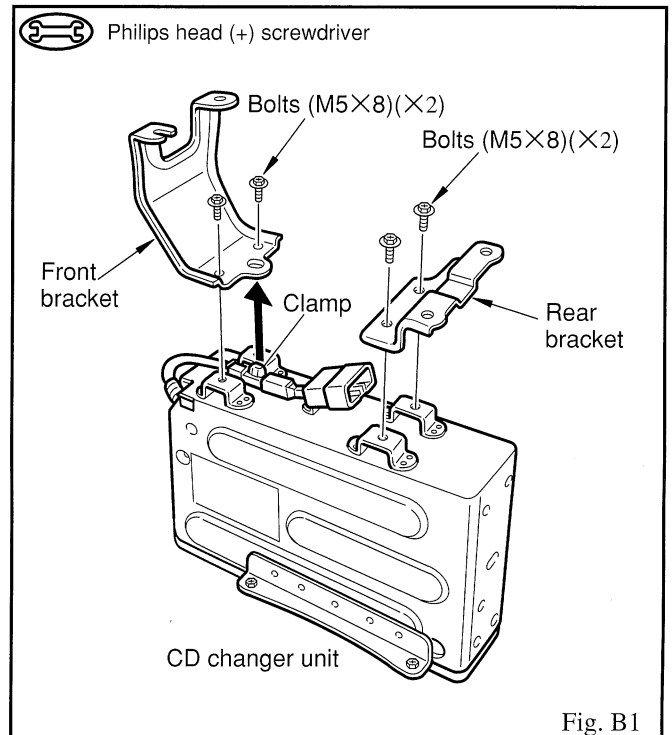

- ii. Connect the CD changer harness. (Fig. B3)



- iii. Secure the front and yaw rate sensor brackets together. (Fig. B3)
 - The installation bolts must be tightened according to the specified torque (T=12.5 N · m).

- iv. Attach the rear bracket, on the console installation bracket, with bolts. (Fig. B3)

B-2. Installing the changer unit

(With a vehicle not equipped with a yaw rate sensor)

- ➔ 1. Install the brackets on the CD changer unit. (Fig. B4)



- Install the CD changer unit while being careful not to scratch it.
 - i. Insert the clamp of the cord onto the front bracket.
 - ii. Install the front bracket onto the CD changer unit.
 - iii. Install the rear bracket onto the CD changer unit.

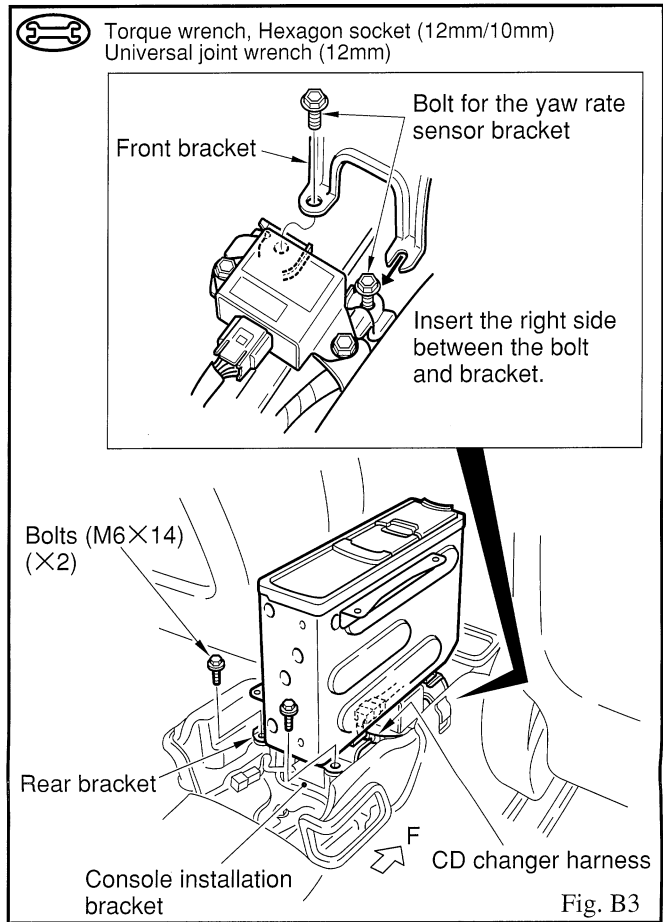

Fig. B3

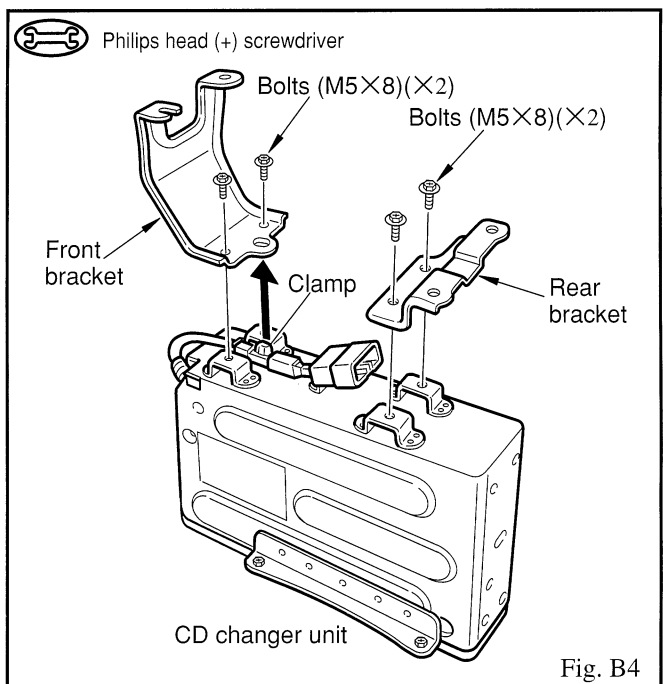
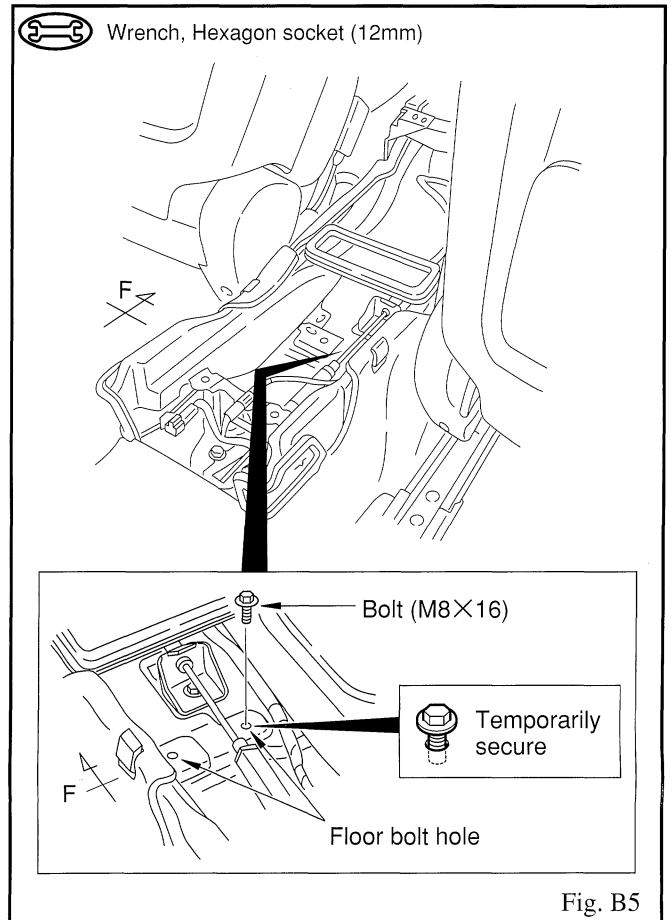
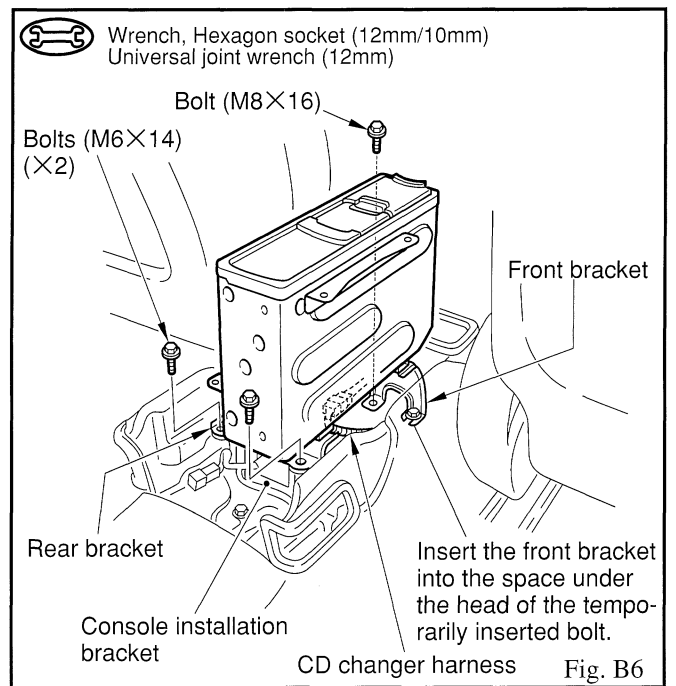

Fig. B4

- ➔ 2. Install the CD changer unit on the floor.
 - i . Temporarily insert the bolt in the front bracket installation bolt hole (light side). (Fig. B5)



- ii . Connect the CD changer harness. (Fig. B6)
- iii . Secure the front bracket with the bolt. (Fig. B6)
- iii . Attach the rear bracket, on the console installation bracket, with bolts. (Fig. B6)



C. Installing the CD changer box



- Install the CD changer box while being careful not to scratch it.



1. Install the heater ducts (L and R), which were previously removed. (Fig. C1)



2. Insert the spring nuts in the screw holes of the heater duct. (Fig. C1)



3. Attach the accessory power socket (which was previously removed from the inner box), to the CD changer box.

- i. Insert the sleeve into the round hole on the CD changer box. (Fig. C2)



- Push it in firmly, until the hooks on the left and right are securely locked. (Fig. C2)

- ii. Insert the accessory power socket into the sleeve. (Fig. C2)



- Push it in firmly, until it locks. (Fig. C2)

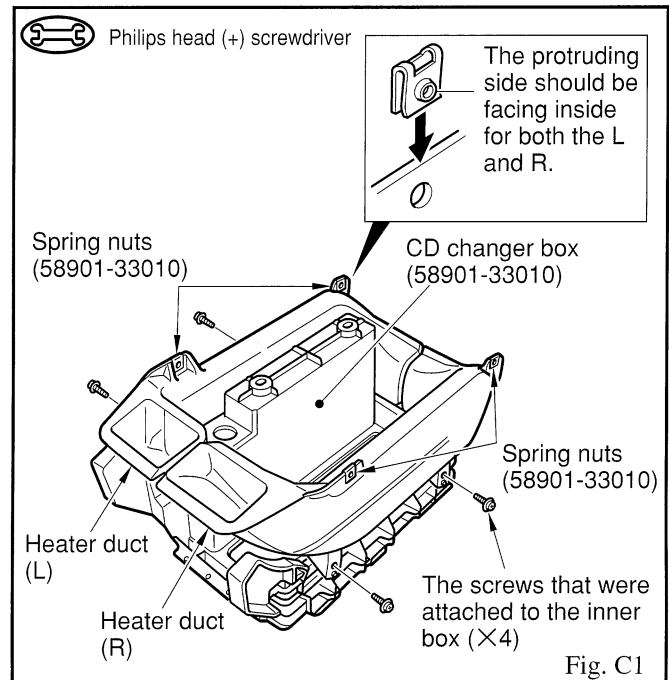
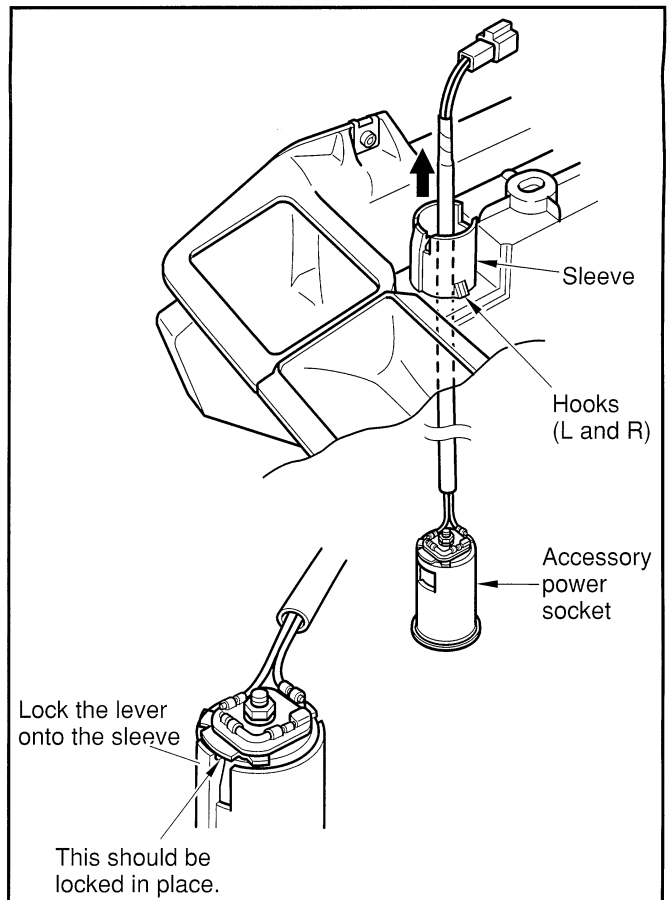
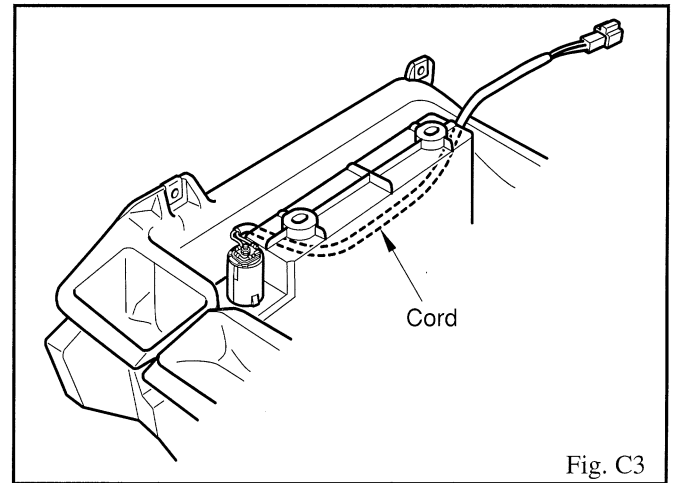

Fig. C1



- iii. Insert the accessory power code between the CD changer box and the heater duct. (Fig. C3)



- ➔ 4. Install the CD changer box and heater ducts (L and R) onto the rear console box. (Fig. C4)



- Install the components while being careful not to scratch the rear console box.
 - i . Secure the heater ducts (L and R) with four screws.
 - ii . Secure the CD changer box with two screws.

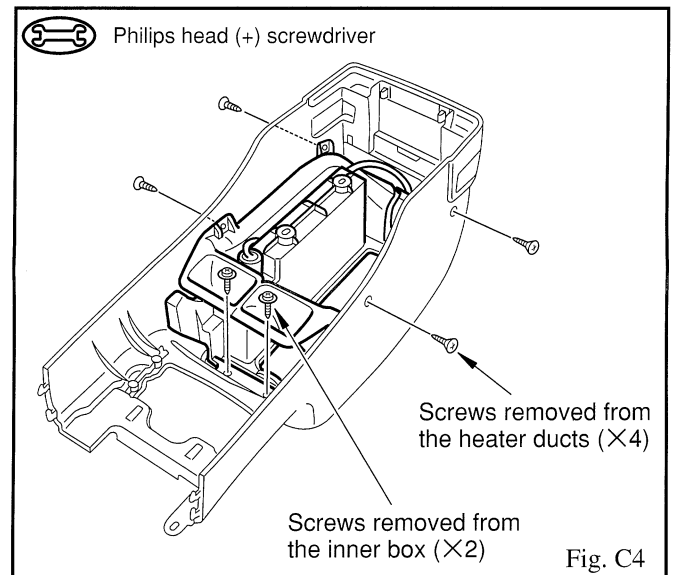

D. Installing the rear console box



- Installations should be performed while taking care not to scratch the rear console box.

- ➔ 1. Install the drink holder onto the rear console box. (Refer to Fig. A5 on page 3.)
- ➔ 2. Install the heater duct panel and lid onto the rear console box. (Refer to Fig. A4 on page 3.)

➔ 3. Install the rear console box onto the floor. (Fig. D1)



• Installations should be performed while taking care not to scratch the CD changer unit.

- i . Connect the connector of the accessory power cord to the harness of the vehicle.
- ii . Secure the front side with screws.
- iii . Bolt down the CD changer box component onto the CD changer bracket.
- iv . Place the mats over the location where the CD changer box is bolted.

E. Completing the installation

➔ 1. Complete the reassembly of the vehicle.

- i . Reconnect any disconnected connectors.
- ii . Verify the panels fit together properly with no uneven gaps between them.

➔ 2. Clean up and remove any trash.

➔ 3. Reconnect the vehicle's negative battery cable. (Fig. E1)



i . Tighten the nut with 3 ft · lbs of torque.



ii . Be careful to not touch the positive terminal.

➔ 4. Place the owner's manual left in their protective bags, in the glove box.

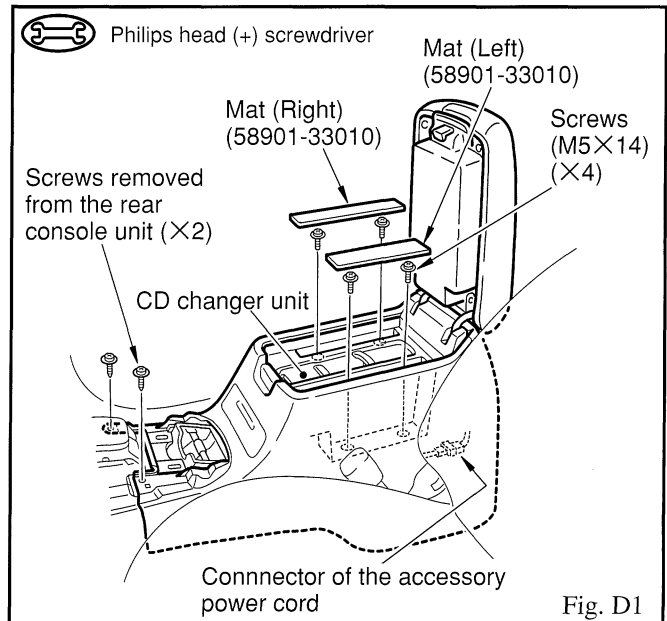

Fig. D1

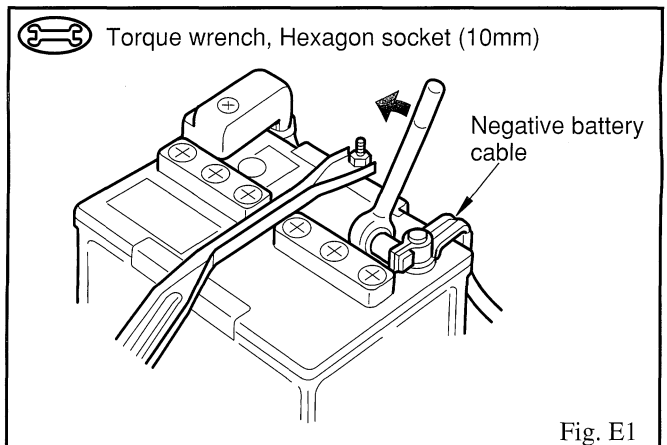

Fig. E1



Section III — Functional Verifications

Check : _____

- Verify that the CD changer operates normally, by referring to the owner's manual.
- Verify that the power is being supplied to the accessory power socket.

PERFORM VSC SENSOR SIGNAL CHECK

A. Procedures for test mode.

- 1. Turn the ignition switch OFF.
- 2. Check that the shift lever position is at P range. Turn the steering wheel to the straight-ahead position.
- 3. Using SST, connect terminals Ts and CG of DLC3.

SST 09843-18040

- 4. Start the engine.

Look For : _____

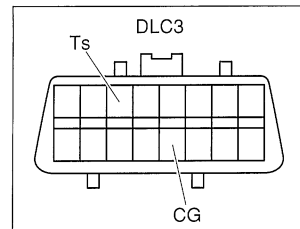

Check that the VSC warning light blinks.

HINT :

If the VSC warning light does not blink, inspect the VSC warning light circuit and Ts terminal circuit.

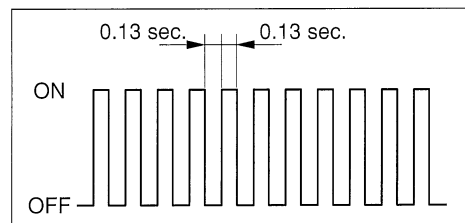



Section III — Functional Verifications

Check :

B. Check the yaw rate sensor.

- Shift the shift lever to the D range and drive the vehicle at the vehicle speed of approx. 5 km/h (3 mph). Turn the steering wheel either to left or right for 90° or more, and maintain 180° circular drive for the vehicle.
- Stop the vehicle and shift the shift lever to the P range. Check that the VSC warning buzzer sounds for 3sec.

HINT :

- Drive the vehicle circularly by 180°. At the end of the turn, the direction of the vehicle should be within 180° $\pm 5^\circ$ from its start position.
- Do not spin the wheels.

C. After doing the check, disconnect the SST from terminals Ts and CG, Tc and CG of DLC3 and turn the ignition switch OFF.

SST 09843-18040

Look For :

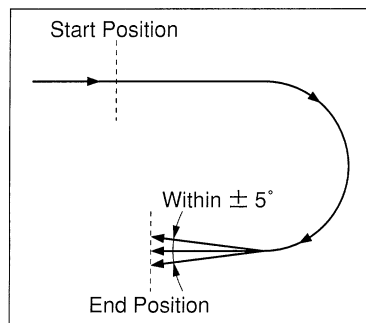

If the VSC warning buzzer sounds, the sensor check is in normal completion.

If the VSC warning buzzer does not sound, check the VSC warning buzzer circuit, then do the sensor check again.

If the VSC warning buzzer still does not sound, there is malfunction in the VSC sensor, so check the DTC.

Section IV : Process / Audit Criteria

Process



Audited during accessory installation

Paragraph number refer to Paragraph numbers in Section II

Audit



Audited on completed vehicle installation

Part Number : 86270-33090

A. Vehicle Disassembly



1. Remove the negative battery cable.
(Fig. A1)



i . Protect the fender before starting.



ii . Be careful to not touch the positive terminal.



2. Remove the shift lever panel, then the front console's upper panel. (Fig. A2)



i . Place a protective cover over the seats and the instrumental panel before starting this procedure.



ii . Remove the panels while being careful not to scratch them.



3. Remove the rear console box. (Fig. A3)



iii . Remove the console box while being careful not to scratch it.



4. Remove various parts and components from the rear console box.



- Remove the console box, being careful not to scratch it.



5. Remove the parts and components off the inner box.

- ii . Remove the plug of the accessory power socket. (Fig. A7)

- Please be careful not to lose any parts or components, as everything, except for the inner box, will be reused.

- Since the clamp will not be used, remove it from the cord.

Section IV : Process / Audit Criteria

Process



Audited during accessory installation

Paragraph number refer to Paragraph numbers in Section II

Audit



Audited on completed vehicle installation

B — 1. Installing the changer unit (With a vehicle equipped with a yaw rate sensor)

➔ 1. Install the brackets on the CD changer unit. (Fig. B1)



- Install the CD changer unit while being careful not to scratch it.

➔ 2. Install the CD changer unit on the floor.

i . Remove the installation bolt (L) on the yaw rate sensor bracket, while loosening the installation bolt (R). (Fig. B2)

- Do not give impact on to the yaw rate sensor. If the yaw rate sensor is hit by tools and damaged, replace the yaw rate sensor with a new one and take necessary calibration process.

iii. Secure the front and yaw rate sensor brackets together. (Fig. B3)

- The installation bolts must be tightened according to the specified torque (T=12.5 N · m).

B — 2. Installing the changer unit (With a vehicle not equipped with a yaw rate sensor)

➔ 1. Install the brackets on the CD changer unit. (Fig. B4)



- Install the CD changer unit while being careful not to scratch it.

➔ 2. Install the CD changer unit on the floor.

Section IV : Process / Audit Criteria

Process



Audited during accessory installation

Paragraph number refer to Paragraph numbers in Section II

Audit



Audited on completed vehicle installation

C. Installing the CD changer box



- Install the CD changer box while being careful not to scratch it.



1. Install the heater ducts (L and R), which were previously removed. (Fig. C1)



2. Insert the spring nuts in the screw holes of the heater duct. (Fig. C1)



3. Attach the accessory power socket (which was previously removed from the inner box), to the CD changer box.

- i . Insert the sleeve into the round hole on the CD changer box. (Fig. C2)

- ii . Insert the accessory power socket into the sleeve. (Fig. C2)



4. Install the CD changer box and heater ducts (L and R) onto the rear console box. (Fig. C4)



- Install the components while being careful not to scratch the rear console box.

D. Installing the rear console box



- Installations should be performed while taking care not to scratch the rear console box.



1. Install the drink holder onto the rear console box. (Refer to Fig. A5 on page 3.)



2. Install the heater duct panel and lid onto the rear console box. (Refer to Fig. A4 on page 3.)

- Push it in firmly, until the hooks on the left and right are securely locked. (Fig. C2)
- Push it in firmly, until it locks. (Fig. C2)

Section IV : Process / Audit Criteria

Process



Audited during accessory installation

Paragraph number refer to Paragraph numbers in Section II

Audit



Audited on completed vehicle installation

- ➔ 3. Install the rear console box onto the floor.
(Fig. D1)



- Installations should be performed while taking care not to scratch the CD changer unit.

E. Completing the installation

- ➔ 1. Complete the reassembly of the vehicle.

- ➔ 2. Clean up and remove any trash.

- ➔ 3. Reconnect the vehicle's negative battery cable. (Fig. E1)



- ii . Be careful to not touch the positive terminal.

- ➔ 4. Place the owner's manual left in their protective bags, in the glove box.

- i . Tighten the nut with 3 ft · lbs of torque.

Free Manuals Download Website

<http://myh66.com>

<http://usermanuals.us>

<http://www.somanuals.com>

<http://www.4manuals.cc>

<http://www.manual-lib.com>

<http://www.404manual.com>

<http://www.luxmanual.com>

<http://aubethermostatmanual.com>

Golf course search by state

<http://golfingnear.com>

Email search by domain

<http://emailbydomain.com>

Auto manuals search

<http://auto.somanuals.com>

TV manuals search

<http://tv.somanuals.com>