



**TRANE®**

# Split System Cooling Units

---

**Split System Cooling Units  
TTA075A-TTA200B  
Air Handlers  
TWE050A-TWE200B  
50 Hz**



---

**December 2000**

**SS-PRC003-EN**



## Introduction

---

*Simply*

**THE BEST VALUE<sup>SM</sup>**



### **Split System Heat Pump Units... Designed With Your Needs In Mind.**

The Trane reputation for quality and reliability in air conditioning continues with the Odyssey™ family of light commercial split systems. Trane paid attention to your needs to make sure you get a system that will meet your job requirements every time...and at a competitive price.

Couple Trane's reputation for quality and reliability in split system air conditioners with efficiency, flexibility, and installation ease...and you have systems that will give you "Simply the Best Value."

# Contents

---

<b>Introduction</b>	2
<b>Features and Benefits</b>	4
<b>Application Considerations</b>	7
<b>Selection Procedure</b>	8
Model Number Description	9
<b>General Data</b>	10
<b>Performance Data</b>	13
Cooling Performance	13
Fan Performance	39
<b>Electric Power</b>	46
<b>Connection and Wiring</b>	48
<b>Dimension and Weights</b>	54
<b>Mechanical Specifications</b>	75

# Features and Benefits

---

## Condensing Units

- Trane 3-D® scroll compressor (TTA075-100A)
- (2) Trane Climatuff™ compressors (TTA100-125B) with independent refrigerant circuits
- (2) Trane 3-D scroll compressors (TTA155-200B) with independent refrigerant circuits
- 2) Manifolder scroll compressors with unloading capability (TTA100-155C)
- Compressor motor overload protection
- Control transformer
- High and low pressure cutout switches
- Internal pressure relief valve (TTA100B-125B)
- Liquid line filter drier, factory installed
- Holding charge of nitrogen
- Copper tube, aluminum plate fin coils
- Low ambient cooling to 35°F (1.7°C) as manufactured
- Weather resistant baked enamel finish
- Heavy gauge steel cabinet
- Mounting/lifting rails under base

### All condensing units offer these optional accessories:

- Head Pressure Control — Low Ambient Cooling To 0°F (-17.8°C)
- Coil Guards Kits
- Isolators both Rubber-in-Shear and Spring Type
- Anti-Short-Cycle Kit
- Time Delay Relay
- Black Epoxy Coated Condenser Coils

## Air Handlers

- Low voltage terminal board
- Expansion valve(s)
- Convertible
- PVC drain pan
- Fan relay
- Efficient evaporator coil
- Baked enamel finish
- Filter access panel
- 1" (25.4 mm) throwaway filters standard with provisions for field supplied 2" (50.8 mm) filters
- Adjustable belt drive motor
- Single point power entry to electric heaters
- Refrigerant piping and/or electrical connections provided from either side

### Odyssey™ air handler versatility is further increased by a complete line of optional accessories designed to match and easy to install:

- Discharge Plenum and Grille
- Return Grille
- Subbase
- Electric Heaters
- High Static Evaporator Motor
- Isolators both Rubber-in-Shear and Spring Type

# Features and Benefits

---

## Condensing Units Options

The Odyssey™ split system product line includes condensing units in both single unloading and dual compressor options.

TTA075A and TTA100A-ton single compressor models feature single refrigeration circuitry lowering job installation costs by requiring only one set of refrigerant lines. These units are ideal for their low cost, new construction jobs, as well as renovation and replacement buildings.

Equally important, Odyssey offers a single refrigerant circuit/capacity unloading option in TTA100C and TTA155C condensing units. These unloading units feature dual manifolded scroll compressors. They offer an excellent opportunity for both new construction and replacement jobs with two stages of capacity modulation and a single refrigeration circuit.

In addition, Odyssey models TTA100B, TTA125B, TTA155B and TTA200B are dual compressor units to give true standby protection; if one compressor fails, the second will automatically start-up. Also, the first compressor can be serviced without shutting down the unit since refrigerant circuits are independent.

Dual compressors are not just for protection; they also save energy costs. Most buildings are designed for the peak load requirements, yet the building usually operates at less than peak load. During light load conditions only one compressor functions to maintain the space comfort thus reducing the need for energy.

Trane split systems have been specified in thousands of applications. You will find Odyssey will win even more jobs with its smaller, more manageable cabinet.

## Low Ambient Cooling Operation

Each condensing unit can operate to 35°F (1.7°C) as standard. An accessory Head Pressure Control gives you the capability to operate to 0°F (-17.8°C).



# Features and Benefits

---

## **Air Handlers Offer More Flexibility**

Flexibility is a key to meeting changing market requirements. Odyssey split systems offer not only various compressor options but also convertible air handlers. The air handlers can be installed either vertically in a mechanical room or horizontally above a ceiling. They do not require any removal of panels or reconfiguration of the drain pan to make either airflow application work. These air handlers have a double sloped condensate drain pan that allows for either airflow configuration and can easily be removed for cleaning. All the air handlers feature factory installed belt drive and ball bearing evaporator fans with adjustable sheaves for maximum airflow performance. The standard motor on the TWE100A air handler will deliver 3325 cfm (5650 m<sup>3</sup>/h) at 1.0" (250 Pa) ESP. Additionally, oversized motors are available for higher static applications.

Odyssey air handler versatility is further increased by a complete line of accessories designed to match and install smoothly:

- Discharge Plenum and Grille
- Return Grille
- Subbase
- Electric Heaters
- High Static Evaporator Motor
- Isolators both Rubber-in-Shear and Spring Type
- A Full Line of Thermostats

## **Odyssey™ — A Complete Split System**

Odyssey delivers the flexibility to select a complete system that meets your particular job requirements. Air Handlers are designed, tested, and rated with condensing units to let you select the proper match between capacity and load. Condensing units can also be matched with Trane built-up air handlers. These matched systems can be quickly engineered for specific applications using Trane's computerized selection programs.



# Application Considerations

Application of this product should be within the catalogued airflow and performance considerations.

## Clearance Requirements

The recommended clearances identified with unit dimensions should be maintained to assure adequate serviceability, maximum capacity and peak operating efficiency. Actual clearances that appear inadequate should be reviewed with your local Trane Representative.

## Low Ambient Cooling

As manufactured, these units can operate to 35°F (1.7°C) in the cooling mode of operation. An accessory head pressure control will allow operation to 0°F (-17.8°C) outdoor ambient. When using these units with control systems such as bypass changeover Variable Air Volume, consider the requirement for a head pressure control to allow low ambient cooling.

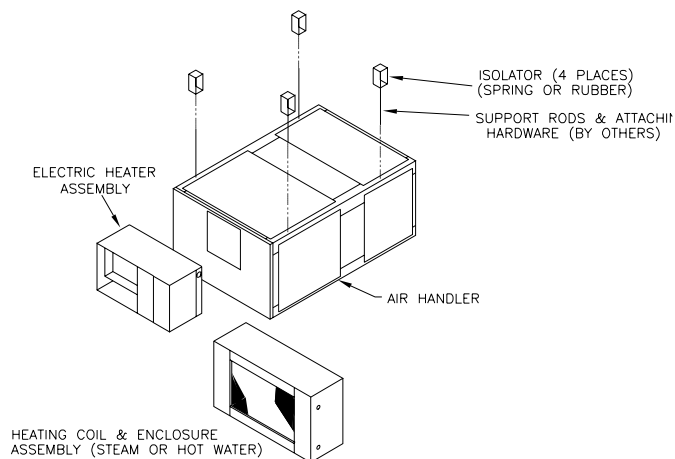

**Typical Horizontal Air Handler Application**

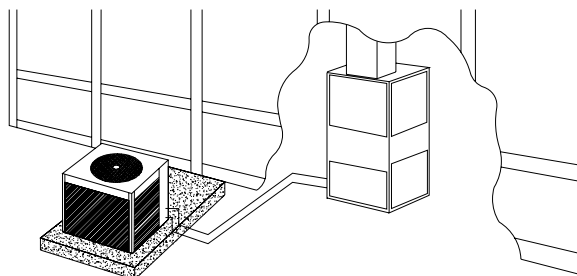

**Typical Split System Application**

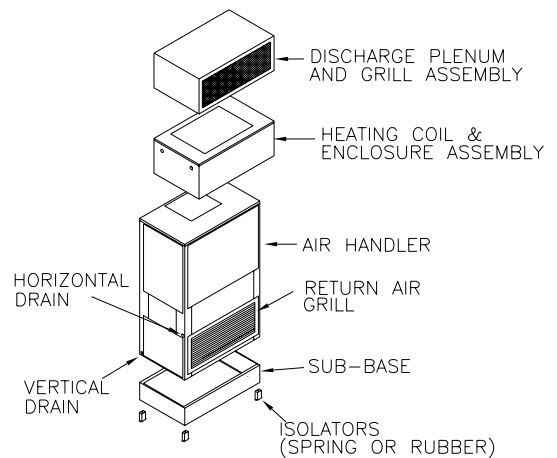

**Typical Vertical Air Handler Application**



# Selection Procedure

## Cooling Capacity

**Step 1** — Calculate the building's total and sensible cooling loads at design conditions. Use the Trane calculation form or any other standard accepted method.

**Step 2** — Size the equipment using Table 13-1. Match the cooling loads at design conditions.

Example: The following are the building cooling requirements

- a**  
Electrical Characteristics: 380-415/50/3
- b**  
Summer Design Conditions: Entering Evaporator Coil: 80 DB/67 WB (27 DB/19 WB C)  
Outdoor Ambient: 95° F (35° C)
- c**  
Total Cooling Load: 75 MBh (22 kW)
- d**  
Sensible Cooling Load: 53 MBh (15.5 kW)
- e**  
Airflow: 3000 cfm (5097 m<sup>3</sup>/h)  
External Static Pressure: 0.77 in. (192.5 Pa)

Table 13-1 shows that a TTA075A matched with a TWE075A has a gross cooling capacity of 77.7 MBh (22.8 kW) and 57.3 MBh (16.8 kW) sensible capacity at 95 DB (35° C) ambient and 3000 cfm (5097 m<sup>3</sup>/h) and 80 DB/67 WB (27 DB/19 WB) air entering the evaporator.

To find the net cooling capacities, fan motor heat must be subtracted. Determine the total unit static pressure:

	In.	Pa
External Static	0.77	193
Standard Filter	0.10	25
Supplementary		
Electric Heat	0.23	57
Total Static Pressure	1.10	275

Note: The Evaporator Fan Performance Table has included the effect of a 1 in. (250 Pa) filter already. Therefore, the actual Total Static Pressure is 1.10 - 0.10 = 1.00 in. (275 - 25 = 250 Pa).

With 3000 cfm (5097 m<sup>3</sup>/h) and 1.00 inches (250 Pa), Table 39-1 shows a 1.17 bhp (0.8 kW).

Note: The formula below the table can be used to calculate Fan Motor Heat,

$$3.5 \times \text{Bhp} = \text{MBh}$$

$$3.5 \times 1.17 = 4.10 \text{ MBh}$$

$$1.375 \times (\text{kW}) = \text{kW}$$

$$1.375 \times 0.8 = 1.1 \text{ kW}$$

$$\text{Net Total Cooling Capacity} =$$

$$77.7 \text{ MBh} - 4.10 = 73.6 \text{ MBh}$$

$$16.8 - 1.2 = 15.6 \text{ kW}$$

$$\text{Net Sensible Cooling Capacity} =$$

$$57.3 \text{ MBh} - 4.10 = 53.2 \text{ MBh}$$

$$22.8 - 1.2 = 21.6 \text{ kW}$$

## Heating Capacity

**Step 1** — Calculate the building heating load.

**Step 2** — Size the system heating capacity to match the calculated building heating load. The following are building heating requirements:

- a**  
Total Heating Load at 97.0 MBh (28.4 kW)
- b**  
3000 cfm (5097 m<sup>3</sup>/h)
- c**  
Electric Supplementary Heaters

Table 45-1, the 34.88 kW heater has a capacity of 119,045 btu. From Table 47-1, the 34.88 kW indicates the heater model number is BAYHTRL435A. This heater will adequately cover the building's heating requirement.

## Air Delivery Selection

External static pressure drop through the air distribution system has been calculated to be 0.77 inches (192.5 Pa) of water gauge. From Table 44-2 static pressure drop through the electric heater is 0.23 inches (57.5 Pa) of water (0.77 + 0.23 = 1.00 in.) (192.5 + 57.5 = 250 Pa). Enter Table 39-1 for TWE075AD at 3000 cfm (5097 m<sup>3</sup>/h) and 1.00 static pressure (250 Pa). The standard motor at 821 rpm will give the desired airflow.





# Model Number Description

## CONDENSING UNIT MODEL NOMENCLATURE

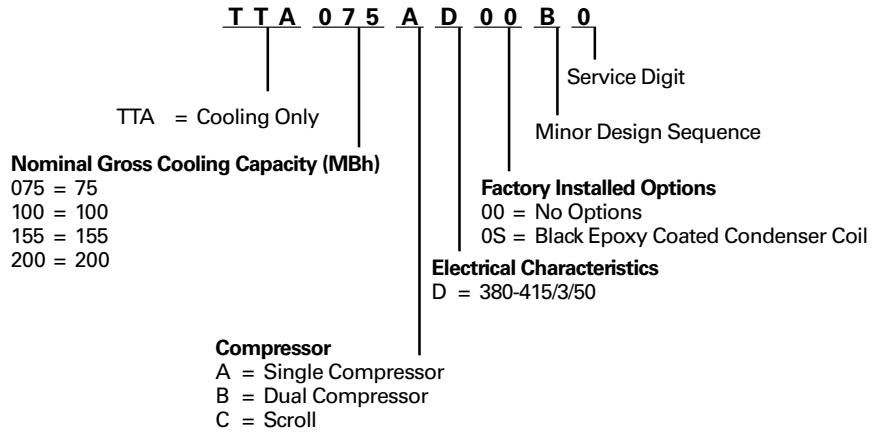

## AIR HANDLER MODEL NOMENCLATURE

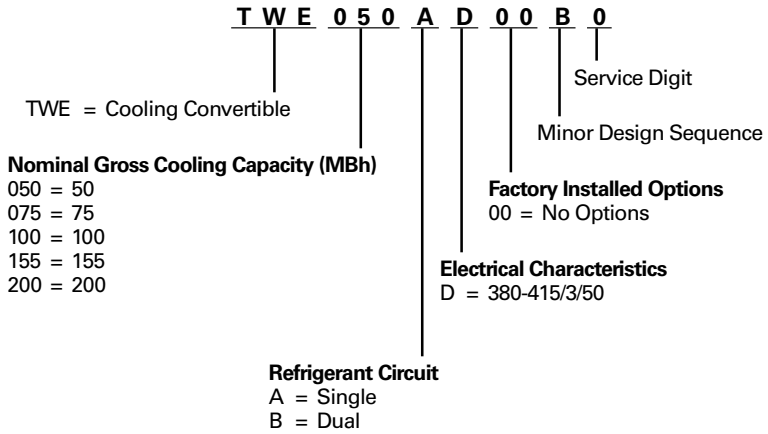



# General Data

# Condensing Unit

**Table GD-1 — General Data**

	TTA075A	TTA085A	TTA100A	TTA100B
<b>Cooling Performance<sup>1</sup></b>				
Gross Cooling Capacity, btu (kW)				
Matched Air Handler (kW)	82,000(24.01)	91,000(26.64)	111,000(32.59)	102,000(30.0)
Condensing Unit Only <sup>2</sup> (kW)	80,000(23.36)	91,000(26.64)	107,000(31.36)	102,000(30.0)
ARI Net Cooling Capacity <sup>3</sup> (kW)	79,000(23.06)	87,000(25.47)	107,000(31.36)	100,000(29.3)
System Power kW	7.92	8.7	10.66	11.3
Condensing Unit Power kW	7.32	7.8	9.76	10.3
<b>Compressor</b>				
Number	1	1	1	2
Type	Trane 3-D® Scroll	Trane 3-D® Scroll	Trane 3-D® Scroll	Trane Climatuff™
No. Speeds	1	1	1	2
No. Motors	1	1	1	2
Motor HP (kW)	6.25 (4.7)	6.91(5.16)	8.33(6.21)	4.15(3.1)
Motor RPM	2875	2875	2875	2875
<b>ARI Sound Rating (Bels)<sup>4</sup></b>	8.8	8.8	8.8	9.0
<b>System Data<sup>5</sup></b>				
No. Refrigerant Circuits	1	1	1	2
Suction Line in. (mm) OD	1.375(34.9)	1.375(34.9)	1.375(34.9)	1.120(28.5)
Liquid Line in. (mm) OD	0.500(12.7)	0.500(12.7)	0.500(12.7)	0.375(9.5)
<b>Outdoor Coil — Type</b>				
	Plate Fin	Plate Fin	Plate Fin	Plate Fin
Tube Size in. (mm) OD	0.375(9.5)	0.375(9.5)	0.375(9.5)	0.375(9.5)
Face Area, sq. ft (m <sup>2</sup> )	15.33(1.42)	18.43(1.71)	18.4(1.71)	18.43(5.6)
Rows	2	2	2	2
Fins Per Inch	20(508)	20(508)	20(508)	20(508)
<b>Outdoor Fan Type</b>				
	Propeller	Propeller	Propeller	Propeller
No. Used	1	1	1	1
Diameter in. (mm)	26.00(660.4)	28.00(711.2)	28.00(711.2)	28.00(711.2)
Drive Type	Direct	Direct	Direct	Direct
No. Speeds	1	1	1	1
CFM <sup>6</sup> (m <sup>3</sup> /h)	4700(7985)	6500(11042)	6500(11042)	6500(11042)
No. Motors	1	1	1	1
Motor HP (kW)	0.33(.24)	0.75(.56)	0.75(.56)	0.75(.55)
Motor RPM	925	925	925	925
<b>R-22 Refrigerant Charge, lb<sup>7</sup> (kg)</b>	13.0(5.90)	16.0(7.26)	16.0(7.26)	18.8(8.5)

**Notes:**

- Cooling Performance is rated at 95°F (35°C) ambient, 80°F (26.7°C) entering dry bulb, 67°F (19.4°C) entering wet bulb and nominal cfm listed. ARI rating cfm is 350 cfm/ton for this product. Gross capacity does not include the effect of fan motor heat. ARI capacity is net and includes the effect of fan motor heat. Units are suitable for operation to ±20% of nominal cfm. Certified in accordance with the Unitary Large Equipment certification program, which is based on ARI Standard 340/360-93.
- Condensing Unit Only Gross Cooling Capacity rated at 45°F (7.2°C) saturated suction temperature and at 95°F (35°C) ambient.
- ARI Net Cooling Capacity is calculated with matched blower coil and 25 ft (7.2 m) of 1.375, 0.500 OD interconnecting tubing. EER and/or SEER are rated at ARI conditions and in accordance with DOE test procedures. Integrated Part Load Value is based on ARI Standard 210/240/340. Units are rated at 80°F (26.7°C) ambient, 80°F (26.7°C) entering dry bulb, and 67°F (19.4°C) entering wet bulb at ARI rated cfm.
- Sound Rating shown is tested in accordance with ARI Standard 270.
- System Data based on maximum linear length 80 ft (26.7 m) Maximum lift: suction 60 ft (18.3 m) liquid 60 ft (18.3 m) For greater lengths, refer to refrigerant piping applications manual.
- Outdoor Fan cfm is rated with standard air-dry coil outdoor.
- Refrigerant (operating) charge is for condensing unit (all circuits) with matching blower coils and 25 ft (7.6 m) of interconnecting refrigerant lines.



# General Data

# Condensing Unit

**Table GD-2— General Data**

	TTA100C	TTA125B	TTA155B	TTA155C	TTA200B
<b>Cooling Performance<sup>1</sup></b>					
Gross Cooling Capacity, btu (kW)					
Matched Air Handler	108,000(31.62)	127,000(37.2)	166,000(48.60)	160,000(46.85)	216,000(63.24)
Condensing Unit Only <sup>2</sup>	108,000(31.62)	127,000(37.2)	163,000(47.73)	155,000(45.39)	209,000(61.18)
ARI Net Cooling Capacity <sup>3</sup>	106,000(31.05)	123,000(36.0)	161,000(47.14)	153,000(44.80)	209,000(61.18)
System Power kW	9.61	13.1	16.01	15.4	21.40
Condensing Unit Power kW	9.01	12.1	14.58	14.6	19.39
<b>Compressor</b>					
Number	2	2	2	2	2
Type	Scroll Tandem	Trane Climatuff <sup>™</sup>	Trane 3-D <sup>®</sup> Scroll	Trane 3-D <sup>®</sup> Scroll Tandem	Trane 3-D <sup>®</sup> Scroll
No. Speeds	2	1	1	1	1
No. Motors		2	2	1	2
Motor HP (kW)	4.16(3.10)	5.20(3.9)	6.25(4.7)	6.25(4.7)	8.33(6.21)
Motor RPM	2875	2875	2875	2875	2875
<b>ARI Sound Rating (Bels)<sup>4</sup></b>					
	8.8	8.8	8.8	8.8	8.8
<b>System Data<sup>5</sup></b>					
No. Refrigerant Circuits	1	2	2	1	2
Suction Line in. (mm) OD	1.375(34.9)	1.375(34.9)	1.375(34.9)	1.625(41.3)	1.375(34.9)
Liquid Line in. (mm) OD	0.500(12.7)	0.500(12.7)	0.500(12.7)	0.625(15.9)	0.500(12.7)
<b>Outdoor Coil — Type</b>					
Tube Size in. (mm) OD	Plate Fin	Plate Fin	Plate Fin	Plate Fin	Plate Fin
Face Area, sq. ft (m <sup>2</sup> )	0.375(9.5)	0.375(9.5)	0.375(9.5)	0.375(9.5)	0.375(9.5)
Rows	18.4(1.71)	23.97(7.3)	30.66(2.84)	30.66(2.84)	43.9(4.08)
Fins Per Inch	2	2	2	2	2
	20 (508)	18(4572)	20(508)	20 (508)	15(381)
<b>Outdoor Fan Type</b>					
No. Used	Propeller	Propeller	Propeller	Propeller	Propeller
Diameter in. (mm)	1	1	2	2	2
Drive Type	28.00(711.2)	28.00(711.2)	26.00(660.4)	26.00(660.4)	28.00(711.2)
No. Speeds	Direct	Direct	Direct	Direct	Direct
CFM <sup>6</sup> (m <sup>3</sup> /h)	1	1	1	1	1
No. Motors	6500(11042)	6760(11484)	9400(15969)	9400(15969)	13400(22764)
Motor HP (kW)	1	1	1	1	2
Motor RPM	0.75(.56)	0.75(.55)	0.33(.24)	0.33(.24)	0.75(.56)
	925	925	925	925	925
<b>R-22 Refrigerant Charge, lb<sup>7</sup> (kg)</b>					
	15.5(7.03)	25.2(11.4)	26.0(11.8)	27.0(12.34)	36.0(16.33)

**Notes:**

- Cooling Performance is rated at 95°F (35°C) ambient, 80°F (26.7°C) entering dry bulb, 67°F (19.4°C) entering wet bulb and nominal cfm listed. ARI rating cfm is 350 cfm/ton for this product. Gross capacity does not include the effect of fan motor heat. ARI capacity is net and includes the effect of fan motor heat. Units are suitable for operation to ±20% of nominal cfm. Certified in accordance with the Unitary Large Equipment certification program, which is based on ARI Standard 340/360-93.
- Condensing Unit Only Gross Cooling Capacity rated at 45°F (7.2°C) saturated suction temperature and at 95°F (35°C) ambient.
- ARI Net Cooling Capacity is calculated with matched blower coil and 25 ft (7.2 m) of 1.375, 0.500 OD interconnecting tubing. EER and/or SEER are rated at ARI conditions and in accordance with DOE test procedures. Integrated Part Load Value is based on ARI Standard 210/240/340. Units are rated at 80°F (26.7°C) ambient, 80°F (26.7°C) entering dry bulb, and 67°F (19.4°C) entering wet bulb at ARI rated cfm.
- Sound Rating shown is tested in accordance with ARI Standard 270.
- System Data based on maximum linear length 80 ft (26.7 m) Maximum lift: suction 60 ft (18.3 m) liquid 60 ft (18.3 m) For greater lengths, refer to refrigerant piping applications manual.
- Outdoor Fan cfm is rated with standard air-dry coil outdoor.
- Refrigerant (operating) charge is for condensing unit (all circuits) with matching blower coils and 25 ft (7.6 m) of interconnecting refrigerant lines.



# General Data

# Air Handler

**Table GD-3 – General Data**

	TWE050A	TWE075A	TWE100A	TWE100B
<b>System Data<sup>1</sup></b>				
No. Refrigerant Circuits	1	1	1	2
Suction Line in. (mm) OD	1.120(28.4)	1.380(35.0)	1.380(35.0)	1.380(35.0)
Liquid Line in. (mm) OD	0.38(9.7)	0.50(12.7)	0.50(12.7)	0.50(12.7)
<b>Indoor Coil – Type</b>				
Tube Size in. (mm) OD	Plate Fin	Plate Fin	Plate Fin	Plate Fin
Face Area sq. ft (m <sup>2</sup> )	0.375(9.5)	0.375(9.5)	0.375(9.5)	0.375(9.5)
Rows	5.00(.47)	8.07(.75)	11.18(1.0)	11.18(1.0)
Fins Per Inch	3	3	3	3
Refrigerant Control	12	12	12	12
Drain Connection No.	Expansion Valve	Expansion Valve	Expansion Valve	Expansion Valve
Drain Connection Size in. (mm)	4	4	4	4
Drain Connection Type	0.75(19.0)	0.75(19.0)	0.75(19.0)	0.75(19.0)
	PVC	PVC	PVC	PVC
<b>Indoor Fan Type</b>				
No. Used	FC Centrifugal	FC Centrifugal	FC Centrifugal	FC Centrifugal
Diameter in. (mm)	1	1	1	1
Width in. (mm)	12.0(304.8)	15.0(381)	15.0(381)	15.0(381)
Drive Type	12.0(304.8)	15.0(381)	15.0(381)	15.0(381)
No. Speeds	Belt	Belt	Belt	Belt
CFM (m <sup>3</sup> /h)	1	1	1	1
No. Motors	1670(2837)	2500(4247)	3325(5649)	3325(5649)
Motor HP (kW)	1	1	1	1
- Standard/Oversized	0.75/1.0(.55/.74)	1.0/1.5(.74/1.11)	1.5/2.0(1.11/1.49)	1.5/2.0(1.11/1.49)
Motor RPM (Standard)	1425	1425	1425	1425
Motor Frame Size (Standard)	56	56	56	56
<b>Filters – Type</b>				
Furnished	Throwaway	Throwaway	Throwaway	Throwaway
No.	Yes	Yes	Yes	Yes
Recommended Size, in. (mm)	1/1	3	4	4
	16x20x1/20x20x1 (406.4x508x25.4/ 508x508x25.4)	16x25x1 (406.4x635x25.4)	16x25x1 (406.4x635x25.4)	16x25x1 (406.4x635x25.4)

**Notes:**

1. ARI certified with various condensing units per ARI Standard 210/240 or 340/360-93. Refer to Performance Data section in this catalog.

**Table GD-4 – General Data**

	TWE155B	TWE200B
<b>System Data</b>		
No. Refrigerant Circuits	2	2
Suction Line in. (mm) OD	1.38(35.0)	1.38(35.0)
Liquid Line in. (mm) OD	0.500(12.7)	0.500(12.7)
<b>Indoor Coil – Type</b>		
Tube Size in. (mm) OD	Plate Fin	Plate Fin
Face Area sq. ft (m <sup>2</sup> )	0.375(9.5)	0.375(9.5)
Rows	16.33(1.52)	21.63(2.01)
Fins Per Inch	3	3
Refrigerant Control	12	12
Drain Connection No.	Expansion Valve	Expansion Valve
Drain Connection Size in. (mm)	4	4
Drain Connection Type	1.000(25.4)	1.000(25.4)
	PVC	PVC
<b>Indoor Fan Type</b>		
No. Used	FC Centrifugal	FC Centrifugal
Diameter in. (mm)	2	2
Width in. (mm)	15.0(381)	15.0(381)
Drive Type	15.0(381)	15.0(381)
No. Speeds	Belt	Belt
CFM (m <sup>3</sup> /h)	1	1
No. Motors	5000(8494)	6650(11297)
Motor HP – Standard/Oversized	1	1
Motor RPM (Standard)	2.0/3.0(1.49/2.24)	3.0/5.0(2.24/3.72)
Motor Frame Size (Standard)	1425	1425
	145T	184T
<b>Filters – Type</b>		
Furnished	Throwaway	Throwaway
No.	Yes	Yes
Recommended Size, in. (mm)	8	4/4
	15x20x2 (381x508x50.8)	16x20x2/16x25x2 (406.4x508x50.8/ 406.4x635x50.8)

**Notes:**

1. ARI certified with various condensing units per ARI Standard 210/240 or 340/360-93. Refer to Performance Data section in this catalog.



# Performance Data

# System

**Table PD-1 — Gross Cooling Capacities (MBh) TTA075A Condensing Unit with TWE075A Air Handler**

**(I-P)**

CFM		Ambient Temperature (°F)																							
		85						95						105						115					
		Enter. Dry Bulb (°F)		Entering Wet Bulb (°F)																					
Airflow		61	67	73		61	67	73		61	67	73		61	67	73		61	67	73		61	67	73	
2250	75	75.7	59.6	83.5	50.1	91.7	34.0	73.1	58.2	80.5	48.8	88.2	32.7	69.9	56.6	76.9	47.4	84.1	31.3	66.3	54.8	72.9	45.8	79.5	29.8
	80	76.2	69.5	83.7	57.4	92.0	44.6	73.6	68.1	80.6	56.0	88.6	43.3	70.5	66.6	77.1	54.4	84.7	41.8	67.0	64.8	73.2	52.6	80.3	40.3
	85	77.8	77.8	84.1	67.3	92.4	54.9	75.6	75.6	81.1	65.9	89.0	53.6	72.9	72.9	77.6	64.2	85.1	52.2	69.9	69.9	73.7	62.5	80.8	50.6
	90	81.8	81.8	84.6	77.2	92.5	64.8	79.4	79.4	81.6	75.8	89.2	63.4	76.7	76.7	78.3	74.3	85.3	61.8	73.5	73.5	74.5	72.5	81.1	60.1
2500	75	77.3	62.3	85.1	49.2	93.1	34.5	74.5	60.9	81.9	47.8	89.4	33.3	71.2	59.2	78.2	46.3	85.2	31.8	67.5	57.4	74.1	44.6	80.6	30.3
	80	77.9	73.2	85.3	59.9	93.6	46.1	75.2	71.8	82.1	58.5	90.0	44.8	72.0	70.2	78.5	56.8	85.9	43.3	68.5	68.4	74.4	55.0	81.5	41.7
	85	80.4	80.4	85.7	70.6	94.0	57.4	78.0	78.0	82.6	69.2	90.4	56.0	75.2	75.2	78.9	67.6	86.2	54.1	72.0	72.0	74.9	65.7	81.8	52.4
	90	84.6	84.6	86.4	81.6	94.2	67.9	82.0	82.0	83.4	80.2	90.7	66.5	79.1	79.1	79.9	78.6	86.7	64.9	75.8	75.8	75.9	75.9	82.4	63.1
2750	75	78.6	64.9	86.3	50.8	94.2	35.2	75.7	63.4	83.0	49.4	90.4	33.9	72.3	61.7	79.3	47.9	86.1	32.4	68.5	59.8	74.7	45.7	81.4	30.8
	80	79.4	76.7	86.6	62.2	94.8	47.5	76.6	75.3	83.3	60.8	91.1	46.2	73.1	73.1	79.6	59.1	87.0	44.7	69.9	69.9	75.5	57.2	82.5	43.1
	85	82.7	82.7	87.0	73.9	95.3	59.7	80.1	80.1	83.8	72.4	91.4	57.8	77.2	77.2	80.1	70.7	87.3	56.2	73.8	73.8	76.1	68.9	82.9	54.4
	90	86.9	86.9	88.0	85.8	95.5	70.9	84.3	84.3	85.0	84.4	91.9	69.4	81.2	81.2	81.3	81.3	87.9	67.8	77.8	77.8	77.9	77.9	83.4	66.0
3000	75	79.7	67.3	87.4	52.3	95.2	35.7	76.7	65.9	84.0	51.0	91.3	34.3	73.2	64.1	79.8	48.9	86.9	32.8	69.4	62.2	75.6	47.0	82.1	31.2
	80	80.8	80.1	87.7	64.5	95.9	48.8	77.7	77.7	84.4	63.0	92.1	47.5	74.8	74.8	80.6	61.3	87.9	46.0	71.4	71.4	76.4	59.4	83.3	44.4
	85	84.6	84.6	88.2	77.0	96.1	61.3	82.0	82.0	84.9	75.5	92.4	59.8	78.9	78.9	81.2	73.8	88.3	58.2	75.5	75.5	77.1	72.0	83.8	56.3
	90	89.0	89.0	89.1	89.1	96.7	73.7	86.3	86.3	86.4	86.4	93.0	72.3	83.1	83.1	83.2	83.2	88.8	70.6	79.6	79.6	79.6	79.6	84.3	68.8

Dry coil conditions. Total Gross Cooling Capacity (MBh) shown to the left is not applicable. In this case the Sensible Heat Capacity (SHC) is the total capacity.

All capacities shown are gross and have not considered indoor fan heat.  
 To obtain net cooling capacities subtract indoor fan heat.  
 TGC = Total Gross Cooling Capacity  
 SHC = Sensible Heat Capacity

**Table PD-1 — Gross Cooling Capacities (kW) TTA075A Condensing Unit with TWE075A Air Handler**

**(SI)**

m³/h		Ambient Temperature (°C)																							
		29.4				35.0				40.6				46.1											
		Enter. Dry Bulb (°C)		Entering Wet Bulb (°C)																					
Airflow		16.1	19.4	22.8		16.1	19.4	22.8		16.1	19.4	22.8		16.1	19.4	22.8		16.1	19.4	22.8					
3823	24	22.2	17.5	24.5	14.7	26.9	9.9	21.4	17.0	23.6	14.3	25.8	9.6	20.5	16.6	22.5	13.9	24.6	9.2	19.4	16.0	21.4	13.4	23.3	8.7
	27	22.3	20.4	24.5	16.8	26.9	13.1	21.5	20.0	23.6	16.4	25.9	12.7	20.6	19.5	22.6	15.9	24.8	12.3	19.6	19.0	21.4	15.4	23.5	11.8
	29	22.8	22.8	24.6	19.7	27.1	16.1	22.1	22.1	23.7	19.3	26.1	15.7	21.3	21.3	22.7	18.8	24.9	15.3	20.5	20.5	21.6	18.3	23.7	14.8
	32	24.0	24.0	24.8	22.6	27.1	19.0	23.3	23.3	23.9	22.2	26.1	18.6	22.5	22.5	22.9	21.7	25.0	18.1	21.5	21.5	21.8	21.2	23.7	17.6
4248	24	22.6	18.2	24.9	14.4	27.3	10.1	21.8	17.8	24.0	14.0	26.2	9.7	20.8	17.3	22.9	13.6	24.9	9.3	19.8	16.8	21.7	13.1	23.6	8.9
	27	22.8	21.4	25.0	17.5	27.4	13.5	22.0	21.0	24.0	17.1	26.3	13.1	21.1	20.6	23.0	16.6	25.2	12.7	20.1	20.0	21.8	16.1	23.9	12.2
	29	23.5	23.5	25.1	20.7	27.5	16.8	22.8	22.8	24.2	20.3	26.5	16.4	22.0	22.0	23.1	19.8	25.2	15.9	21.1	21.1	21.9	19.3	24.0	15.3
	32	24.8	24.8	25.3	23.9	27.6	19.9	24.0	24.0	24.4	23.5	26.5	19.5	23.2	23.2	23.4	23.0	25.4	19.0	22.2	22.2	22.2	22.2	24.1	18.5
4673	24	23.0	19.0	25.3	14.9	27.6	10.3	22.2	18.6	24.3	14.5	26.5	9.9	21.2	18.1	23.2	14.0	25.2	9.5	20.0	17.5	21.9	13.4	23.8	9.0
	27	23.2	22.5	25.4	18.2	27.8	13.9	22.4	22.1	24.4	17.8	26.7	13.5	21.4	21.4	23.3	17.3	25.5	13.1	20.5	20.5	22.1	16.8	24.2	12.6
	29	24.2	24.2	25.5	21.6	27.9	17.5	23.5	23.5	24.5	21.2	26.8	16.9	22.6	22.6	23.5	20.7	25.6	16.5	21.6	21.6	22.3	20.2	24.3	15.9
	32	25.5	25.5	25.8	25.1	28.0	20.8	24.7	24.7	24.9	24.7	26.9	20.3	23.8	23.8	23.8	23.8	25.7	19.8	22.8	22.8	22.8	22.8	24.4	19.3
5098	24	23.3	19.7	25.6	15.3	27.9	10.4	22.4	19.3	24.6	14.9	26.7	10.0	21.4	18.8	23.4	14.3	25.4	9.6	20.3	18.2	22.1	13.8	24.0	9.1
	27	23.7	23.5	25.7	18.9	28.1	14.3	22.8	22.8	24.7	18.4	27.0	13.9	21.9	21.9	23.6	17.9	25.7	13.5	20.9	20.9	22.4	17.4	24.4	13.0
	29	24.8	24.8	25.8	22.5	28.1	18.0	24.0	24.0	24.9	22.1	27.1	17.5	23.1	23.1	23.8	21.6	25.8	17.0	22.1	22.1	22.6	21.1	24.5	16.5
	32	26.1	26.1	26.1	26.1	28.3	21.6	25.3	25.3	25.3	25.3	27.2	21.2	24.3	24.3	24.4	24.4	26.0	20.7	23.3	23.3	23.3	23.3	24.7	20.2

Dry coil conditions. Total Gross Cooling Capacity (MBh) shown to the left is not applicable. In this case the Sensible Heat Capacity (SHC) is the total capacity.

All capacities shown are gross and have not considered indoor fan heat.  
 To obtain net cooling capacities subtract indoor fan heat.  
 TGC = Total Gross Cooling Capacity  
 SHC = Sensible Heat Capacity



# Performance Data System

**Table PD-2 — Gross Cooling Capacities (MBh) TTA075A Condensing Unit with TWE100A Air Handler (I-P)**

CFM		Ambient Temperature (°F)																							
		85						95						105						115					
		Enter. Dry Bulb (°F)		Entering Wet Bulb (°F)																					
Airflow	61	67	73	61	67	73	61	67	73	61	67	73	61	67	73	61	67	73	61	67	73				
2550	75	79.9	65.5	87.9	54.1	95.9	35.7	76.9	64.0	84.5	52.7	92.0	34.4	73.5	62.2	80.7	51.2	87.7	32.9	69.6	60.3	76.4	49.5	82.9	31.3
	80	80.7	77.2	88.1	62.8	96.6	48.0	77.9	75.8	84.8	61.3	92.8	46.6	74.6	74.1	81.0	59.6	88.6	45.1	70.8	70.8	76.8	57.7	84.0	43.5
	90	88.0	88.0	89.5	86.2	97.2	71.4	85.3	85.3	86.3	84.8	93.5	69.9	82.2	82.2	82.3	82.3	89.4	68.3	78.8	78.8	78.9	78.9	84.9	66.5
2875	75	81.5	69.1	89.5	53.5	97.3	36.4	78.4	67.6	86.0	52.1	93.3	35.1	74.9	65.8	82.0	50.5	88.8	33.5	70.9	63.8	77.2	48.1	83.9	31.8
	80	82.8	82.3	89.8	66.1	98.2	49.9	79.6	79.6	86.3	64.6	94.3	48.5	76.5	76.5	82.4	62.8	90.0	47.0	73.1	73.1	78.1	60.9	85.3	45.4
	90	91.2	91.2	91.2	91.2	98.8	75.6	88.3	88.3	88.4	88.4	95.1	74.1	85.1	85.1	85.2	85.2	90.8	72.5	81.4	81.4	81.5	81.5	86.2	70.7
3200	75	82.9	72.6	90.8	55.7	98.5	37.0	79.8	71.0	86.9	53.7	94.3	35.6	76.1	69.2	82.8	51.9	89.7	34.1	72.1	67.2	78.3	49.9	84.6	32.4
	80	84.6	84.6	91.2	69.3	99.4	51.8	81.8	81.8	87.6	67.7	95.5	50.4	78.6	78.6	83.6	65.9	91.1	48.9	75.0	75.0	79.1	63.9	86.3	47.2
	90	93.9	93.9	93.9	93.9	100.2	79.7	90.9	90.9	90.9	96.3	78.2	87.4	87.4	87.5	87.5	92.1	76.5	83.7	83.7	83.8	83.8	87.4	74.7	
3525	75	84.2	75.9	91.6	57.1	99.4	37.6	80.9	74.3	87.9	55.5	95.1	36.2	77.2	72.5	83.7	53.6	90.4	34.6	73.1	70.4	79.1	51.6	85.1	32.9
	80	86.6	86.6	92.3	72.3	100.5	53.5	83.7	83.7	88.7	70.7	96.5	52.1	80.4	80.4	84.5	68.9	92.0	50.6	76.7	76.7	80.0	66.9	87.1	49.0
	90	96.2	96.2	96.2	96.2	101.4	83.6	93.0	93.0	93.1	93.1	97.5	82.1	89.5	89.5	89.6	89.6	93.1	80.4	85.6	85.6	85.7	85.7	88.5	78.6

Dry coil conditions. Total Gross Cooling Capacity (MBh) shown to the left is not applicable. In this case the Sensible Heat Capacity (SHC) is the total capacity.

All capacities shown are gross and have not considered indoor fan heat.  
 To obtain net cooling capacities subtract indoor fan heat.  
 TGC = Total Gross Cooling Capacity  
 SHC = Sensible Heat Capacity

**Table PD-2 — Gross Cooling Capacities (kW) TTA075A Condensing Unit with TWE100A Air Handler (SI)**

m³/h		Ambient Temperature (°C)																							
		29.4				35.0				40.6				46.1											
		Enter. Dry Bulb (°C)		Entering Wet Bulb (°C)																					
Airflow	16.1	19.4	22.8	16.1	19.4	22.8	16.1	19.4	22.8	16.1	19.4	22.8	16.1	19.4	22.8										
4331	23.9	23.4	19.2	25.7	15.8	28.1	10.5	22.5	18.7	24.7	15.4	26.9	10.1	21.5	18.2	23.6	15.0	25.7	9.6	20.4	17.7	22.4	14.5	24.3	9.2
	26.7	23.6	22.6	25.8	18.4	28.3	14.0	22.8	22.2	24.8	18.0	27.2	13.6	21.8	21.7	23.7	17.5	26.0	13.2	20.7	20.7	22.5	16.9	24.6	12.7
	29.4	24.5	24.5	25.9	21.8	28.4	17.6	23.8	23.8	25.0	21.3	27.3	17.2	22.9	22.9	23.9	20.9	26.1	16.7	21.9	21.9	22.6	20.3	24.7	16.1
4885	23.9	23.9	20.2	26.2	15.7	28.5	10.7	23.0	19.8	25.2	15.3	27.3	10.3	21.9	19.3	24.0	14.8	26.0	9.8	20.8	18.7	22.6	14.1	24.6	9.3
	26.7	24.2	24.1	26.3	19.4	28.7	14.6	23.3	23.3	25.3	18.9	27.6	14.2	22.4	22.4	24.1	18.4	26.3	13.8	21.4	21.4	22.9	17.8	25.0	13.3
	29.4	25.4	25.4	26.4	23.1	28.9	18.5	24.6	24.6	25.5	22.7	27.7	18.0	23.7	23.7	24.3	22.2	26.4	17.5	22.6	22.6	23.1	21.6	25.1	16.9
5436	23.9	24.3	21.2	26.6	16.3	28.8	10.8	23.4	20.8	25.4	15.7	27.6	10.4	22.3	20.3	24.2	15.2	26.3	10.0	21.1	19.7	22.9	14.6	24.8	9.5
	26.7	24.8	24.8	26.7	20.3	29.1	15.2	24.0	24.0	25.7	19.8	28.0	14.8	23.0	23.0	24.5	19.3	26.7	14.3	22.0	22.0	23.2	18.7	25.3	13.8
	29.4	26.1	26.1	26.9	24.4	29.2	19.2	25.3	25.3	25.9	24.0	28.1	18.8	24.3	24.3	24.7	23.5	26.8	18.3	23.2	23.2	23.5	22.9	25.4	17.7
5990	23.9	24.6	22.2	26.8	16.7	29.1	11.0	23.7	21.8	25.7	16.3	27.9	10.6	22.6	21.2	24.5	15.7	26.5	10.1	21.4	20.6	23.2	15.1	24.9	9.6
	26.7	25.4	25.4	27.0	21.2	29.4	15.7	24.5	24.5	26.0	20.7	28.2	15.3	23.5	23.5	24.8	20.2	26.9	14.8	22.4	22.4	23.4	19.6	25.5	14.3
	29.4	26.8	26.8	27.3	25.7	29.5	20.0	25.9	25.9	26.3	25.2	28.4	19.6	24.9	24.9	25.1	24.7	27.1	19.0	23.7	23.7	23.8	23.8	25.7	18.5
32.2	28.2	28.2	28.2	28.2	29.7	24.5	27.2	27.2	27.3	27.3	28.5	24.0	26.2	26.2	26.2	26.2	27.3	23.5	25.1	25.1	25.1	25.1	25.9	23.0	

Dry coil conditions. Total Gross Cooling Capacity (MBh) shown to the left is not applicable. In this case the Sensible Heat Capacity (SHC) is the total capacity.

All capacities shown are gross and have not considered indoor fan heat.  
 To obtain net cooling capacities subtract indoor fan heat.  
 TGC = Total Gross Cooling Capacity  
 SHC = Sensible Heat Capacity



# Performance Data System

**Table PD-3 — Gross Cooling Capacities (MBh) TTA085A Condensing Unit with TWE075A Air Handler (I-P)**

CFM		Ambient Temperature (°F)																							
		85						95						105						115					
		Enter. Dry Bulb (°F)		Entering Wet Bulb (°F)																					
Airflow		61	67	73		61	67	73		61	67	73		61	67	73		61	67	73		61	67	73	
		TGC	SHC	TGC	SHC	TGC	SHC	TGC	SHC	TGC	SHC	TGC	SHC	TGC	SHC	TGC	SHC	TGC	SHC	TGC	SHC	TGC	SHC	TGC	SHC
2250	75	83.0	61.8	92.0	53.4	102.2	37.6	80.0	60.1	88.9	52.1	98.7	36.4	76.9	58.5	85.6	50.7	95.0	35.1	73.7	56.8	82.1	49.3	91.2	33.8
	80	83.2	70.5	92.3	59.7	102.2	48.0	80.4	69.0	89.2	58.3	98.8	46.6	77.4	67.4	86.0	56.8	95.2	45.1	74.2	65.7	82.5	55.3	91.3	43.6
	85	83.7	79.6	92.4	68.8	102.5	57.4	81.1	78.2	89.4	67.3	99.1	56.0	78.2	76.6	86.1	65.7	95.5	54.5	75.3	75.0	82.7	64.1	91.8	53.0
	90	86.2	86.2	92.8	77.8	102.8	66.7	84.0	84.0	89.8	76.3	99.4	65.3	81.5	81.5	86.5	74.7	95.8	63.9	78.9	78.9	83.1	73.1	92.1	62.4
2500	75	84.8	64.2	94.2	52.1	104.4	38.4	81.9	62.6	90.9	50.6	100.8	37.1	78.8	61.0	87.5	49.1	96.9	35.8	75.4	59.2	83.9	47.5	92.9	34.4
	80	85.2	73.9	94.5	62.3	104.5	49.4	82.3	72.4	91.3	60.8	100.9	48.0	79.2	70.7	87.9	59.3	97.1	46.5	75.9	69.0	84.3	57.7	93.2	45.0
	85	86.1	84.0	94.6	72.0	104.8	59.6	83.4	82.5	91.5	70.4	101.2	58.2	80.2	80.2	88.1	68.8	97.5	56.8	77.6	77.6	84.6	67.2	93.6	55.3
	90	89.5	89.5	95.0	81.7	105.1	69.8	87.1	87.1	91.9	80.2	101.6	68.4	84.5	84.5	88.5	78.6	97.9	67.0	81.8	81.8	85.0	76.9	93.8	65.0
2750	75	86.6	66.6	96.0	53.6	106.2	39.2	83.5	65.0	92.6	52.2	102.4	37.9	80.3	63.3	89.0	50.6	98.4	36.5	76.9	61.6	85.3	49.0	94.2	35.1
	80	87.0	77.1	96.3	64.6	106.3	50.8	84.0	75.5	93.0	63.2	102.6	49.3	80.8	73.9	89.2	61.3	98.7	47.8	77.5	72.1	85.6	59.6	94.7	46.3
	85	88.3	88.1	96.5	75.0	106.7	61.8	85.3	85.3	93.2	73.4	103.0	60.4	82.7	82.7	89.8	71.8	99.2	58.9	79.9	79.9	86.1	70.1	95.2	57.4
	90	92.4	92.4	96.9	85.5	107.0	72.8	89.9	89.9	93.6	83.9	103.1	71.0	87.2	87.2	90.2	82.3	99.3	69.4	84.3	84.3	86.7	80.7	95.4	67.7
3000	75	88.1	68.9	97.5	55.1	107.7	39.9	85.0	67.3	94.0	53.6	103.8	38.6	81.6	65.6	90.4	52.1	99.7	37.2	78.1	63.8	86.6	50.5	95.4	35.7
	80	88.5	80.2	97.9	66.9	107.9	52.1	85.5	78.6	94.2	65.0	104.1	50.6	82.2	76.9	90.6	63.4	100.1	49.1	78.9	75.2	86.9	61.6	96.0	47.6
	85	90.2	90.2	98.2	77.8	108.3	63.8	87.7	87.7	94.8	76.2	104.5	62.4	84.9	84.9	91.2	74.6	100.6	60.9	82.1	82.1	87.5	72.8	96.5	59.4
	90	95.0	95.0	98.6	89.1	108.4	75.1	92.3	92.3	95.3	87.6	104.7	73.6	89.5	89.5	91.8	85.9	100.8	72.0	86.6	86.6	88.3	84.3	96.8	70.3

Dry coil conditions. Total Gross Cooling Capacity (MBh) shown to the left is not applicable. In this case the Sensible Heat Capacity (SHC) is the total capacity.

All capacities shown are gross and have not considered indoor fan heat.  
 To obtain net cooling capacities subtract indoor fan heat.  
 TGC = Total Gross Cooling Capacity  
 SHC = Sensible Heat Capacity

**Table PD-3 — Gross Cooling Capacities (kW) TTA085A Condensing Unit with TWE075A Air Handler (SI)**

m³/h		Ambient Temperature (°C)																							
		29.4				35.0				40.6				46.1											
		Enter. Dry Bulb (°C)		Entering Wet Bulb (°C)																					
Airflow		16.1	19.4	22.8		16.1	19.4	22.8		16.1	19.4	22.8		16.1	19.4	22.8		16.1	19.4	22.8					
		TGC	SHC	TGC	SHC	TGC	SHC	TGC	SHC	TGC	SHC	TGC	SHC	TGC	SHC	TGC	SHC	TGC	SHC	TGC	SHC	TGC	SHC		
3823	24	24.3	18.1	26.9	15.6	29.9	11.0	23.4	17.6	26.0	15.3	28.9	10.7	22.5	17.1	25.1	14.9	27.8	10.3	21.6	16.6	24.0	14.4	26.7	9.9
	27	24.3	20.6	27.0	17.5	29.9	14.0	23.5	20.2	26.1	17.1	28.9	13.6	22.7	19.7	25.2	16.6	27.9	13.2	21.7	19.2	24.2	16.2	26.7	12.8
	29	24.5	23.3	27.1	20.1	30.0	16.8	23.7	22.9	26.2	19.7	29.0	16.4	22.9	22.4	25.2	19.2	28.0	16.0	22.0	22.0	24.2	18.8	26.9	15.5
	32	25.3	25.3	27.2	22.8	30.1	19.5	24.6	24.6	26.3	22.3	29.1	19.1	23.9	23.9	25.3	21.9	28.1	18.7	23.1	23.1	24.3	21.4	27.0	18.3
4248	24	24.8	18.8	27.6	15.2	30.6	11.3	24.0	18.3	26.6	14.8	29.5	10.9	23.1	17.9	25.6	14.4	28.4	10.5	22.1	17.3	24.6	13.9	27.2	10.1
	27	25.0	21.6	27.7	18.2	30.6	14.5	24.1	21.2	26.7	17.8	29.5	14.1	23.2	20.7	25.7	17.4	28.4	13.6	22.2	20.2	24.7	16.9	27.3	13.2
	29	25.2	24.6	27.7	21.1	30.7	17.5	24.4	24.1	26.8	20.6	29.6	17.0	23.5	23.5	25.8	20.2	28.6	16.6	22.7	22.7	24.8	19.7	27.4	16.2
	32	26.2	26.2	27.8	23.9	30.8	20.4	25.5	25.5	26.9	23.5	29.7	20.0	24.7	24.7	25.9	23.0	28.7	19.6	24.0	24.0	24.9	22.5	27.5	19.0
4673	24	25.3	19.5	28.1	15.7	31.1	11.5	24.5	19.0	27.1	15.3	30.0	11.1	23.5	18.5	26.1	14.8	28.8	10.7	22.5	18.0	25.0	14.4	27.6	10.3
	27	25.5	22.6	28.2	18.9	31.1	14.9	24.6	22.1	27.2	18.5	30.0	14.4	23.7	21.6	26.1	17.9	28.9	14.0	22.7	21.1	25.1	17.5	27.7	13.6
	29	25.8	25.8	28.3	22.0	31.2	18.1	25.0	25.0	27.3	21.5	30.2	17.7	24.2	24.2	26.3	21.0	29.0	17.2	23.4	23.4	25.2	20.5	27.9	16.8
	32	27.1	27.1	28.4	25.0	31.3	21.3	26.3	26.3	27.4	24.6	30.2	20.8	25.5	25.5	26.4	24.1	29.1	20.3	24.7	24.7	25.4	23.6	27.9	19.8
5098	24	25.8	20.2	28.6	16.1	31.5	11.7	24.9	19.7	27.5	15.7	30.4	11.3	23.9	19.2	26.5	15.2	29.2	10.9	22.9	18.7	25.4	14.8	27.9	10.5
	27	25.9	23.5	28.7	19.6	31.6	15.2	25.0	23.0	27.6	19.0	30.5	14.8	24.1	22.5	26.5	18.6	29.3	14.4	23.1	22.0	25.4	18.0	28.1	13.9
	29	26.4	26.4	28.7	22.8	31.7	18.7	25.7	25.7	27.8	22.3	30.6	18.3	24.9	24.9	26.7	21.8	29.5	17.8	24.0	24.0	25.6	21.3	28.3	17.4
	32	27.8	27.8	28.9	26.1	31.7	22.0	27.0	27.0	27.9	25.6	30.7	21.5	26.2	26.2	26.9	25.2	29.5	21.1	25.4	25.4	25.8	24.7	28.3	20.6

Dry coil conditions. Total Gross Cooling Capacity (MBh) shown to the left is not applicable. In this case the Sensible Heat Capacity (SHC) is the total capacity.

All capacities shown are gross and have not considered indoor fan heat.  
 To obtain net cooling capacities subtract indoor fan heat.  
 TGC = Total Gross Cooling Capacity  
 SHC = Sensible Heat Capacity



# Performance Data System

**Table PD-4 — Gross Cooling Capacities (MBh) TTA085A Condensing Unit with TWE100A Air Handler (I-P)**

CFM		Ambient Temperature (°F)																							
		85						95						105						115					
		Enter. Dry Bulb (°F)		Entering Wet Bulb (°F)																					
Airflow	61	67	73	61	67	73	61	67	73	61	67	73	61	67	73	61	67	73	61	67	73	61	67	73	
2500	75	87.9	67.0	97.4	57.4	107.7	39.8	84.8	65.4	93.9	56.0	103.9	38.3	81.5	63.7	90.3	54.5	99.8	36.8	78.0	61.9	86.5	53.0	95.4	35.5
	80	88.3	77.4	97.8	65.0	107.9	51.3	85.2	75.8	94.4	63.4	104.1	49.8	81.9	74.1	90.8	61.9	100.2	48.3	78.5	72.3	86.7	59.9	96.0	46.7
	85	89.3	88.1	98.0	75.3	108.3	62.2	86.1	86.1	94.6	73.7	104.6	60.7	83.4	83.4	91.0	72.0	100.7	59.2	80.6	80.6	87.3	70.2	96.6	57.6
2800	75	90.0	70.2	99.6	56.2	109.9	40.6	86.8	68.5	96.0	54.6	105.8	39.2	83.4	66.8	92.3	53.0	101.5	37.7	79.8	64.9	88.3	51.4	97.0	36.1
	80	90.5	81.6	100.1	68.1	110.2	53.1	87.3	80.0	96.5	66.5	106.3	51.6	83.9	78.2	92.5	64.5	102.2	50.0	80.5	76.4	88.6	62.7	97.9	48.4
	85	92.0	92.0	100.3	79.2	110.7	65.0	89.4	89.4	96.7	77.5	106.8	63.5	86.6	86.6	93.0	75.8	102.7	62.0	83.6	83.6	89.2	74.1	98.5	60.4
3100	75	91.8	73.2	101.5	58.1	111.6	41.4	88.5	71.5	97.7	56.5	107.3	40.0	85.0	69.7	93.9	54.9	102.9	38.5	81.3	67.8	89.8	53.2	98.3	36.9
	80	92.4	85.7	101.7	70.6	112.1	54.7	89.2	84.0	98.0	68.9	108.0	53.2	85.7	82.2	94.2	67.1	103.8	51.6	82.2	80.4	90.2	65.3	99.4	50.0
	85	95.0	95.0	102.2	82.9	112.7	67.7	92.2	92.2	98.6	81.3	108.6	66.2	89.3	89.3	94.7	79.5	104.4	64.6	86.2	86.2	90.8	77.7	99.7	62.5
3400	75	93.4	76.1	103.0	59.9	113.0	42.2	89.9	74.3	99.2	58.3	108.6	40.7	86.3	72.5	95.2	56.7	104.1	39.1	82.5	70.6	91.1	55.0	99.4	37.4
	80	94.1	89.6	103.3	73.2	113.7	56.3	90.8	87.9	99.5	71.4	109.5	54.8	87.4	86.1	95.6	69.7	105.2	53.2	83.6	83.6	91.5	67.8	100.7	51.6
	85	97.7	97.7	103.9	86.5	114.3	70.3	94.8	94.8	100.1	84.8	110.2	68.7	91.7	91.7	96.2	83.0	105.5	66.6	88.5	88.5	92.1	81.2	101.1	64.8
90	102.9	102.9	104.7	100.1	114.6	83.3	99.9	99.9	101.1	98.4	110.5	81.6	96.7	96.7	97.5	96.7	106.2	79.9	93.4	93.4	93.5	93.5	101.8	78.1	

Dry coil conditions. Total Gross Cooling Capacity (MBh) shown to the left is not applicable. In this case the Sensible Heat Capacity (SHC) is the total capacity.

All capacities shown are gross and have not considered indoor fan heat.  
 To obtain net cooling capacities subtract indoor fan heat.  
 TGC = Total Gross Cooling Capacity  
 SHC = Sensible Heat Capacity

**Table PD-4 — Gross Cooling Capacities (kW) TTA085A Condensing Unit with TWE100A Air Handler (SI)**

m³/h		Ambient Temperature (°C)																							
		29.4				35.0				40.6				46.1											
		Enter. Dry Bulb (°C)		Entering Wet Bulb (°C)																					
Airflow	16.1	19.4	22.8	16.1	19.4	22.8	16.1	19.4	22.8	16.1	19.4	22.8	16.1	19.4	22.8										
4248	24	25.7	19.6	28.5	16.8	31.5	11.6	24.8	19.1	27.5	16.4	30.4	11.2	23.9	18.6	26.4	16.0	29.2	10.8	22.8	18.1	25.3	15.5	27.9	10.4
	27	25.9	22.7	28.6	19.0	31.6	15.0	24.9	22.2	27.6	18.6	30.5	14.6	24.0	21.7	26.6	18.1	29.3	14.1	23.0	21.2	25.4	17.5	28.1	13.7
	29	26.1	25.8	28.7	22.0	31.7	18.2	25.2	25.2	27.7	21.6	30.6	17.8	24.4	24.4	26.6	21.1	29.5	17.3	23.6	23.6	25.6	20.6	28.3	16.9
4756	24	26.4	20.6	29.2	16.4	32.2	11.9	25.4	20.1	28.1	16.0	31.0	11.5	24.4	19.5	27.0	15.5	29.7	11.0	23.4	19.0	25.9	15.0	28.4	10.6
	27	26.5	23.9	29.3	19.9	32.3	15.5	25.6	23.4	28.3	19.5	31.1	15.1	24.6	22.9	27.1	18.9	29.9	14.6	23.6	22.4	25.9	18.3	28.7	14.2
	29	26.9	26.9	29.4	23.2	32.4	19.0	26.2	26.2	28.3	22.7	31.3	18.6	25.3	25.3	27.2	22.2	30.1	18.1	24.5	24.5	26.1	21.7	28.8	17.7
5267	24	26.9	21.4	29.7	17.0	32.7	12.1	25.9	20.9	28.6	16.6	31.4	11.7	24.9	20.4	27.5	16.1	30.1	11.3	23.8	19.9	26.3	15.6	28.8	10.8
	27	27.1	25.1	29.8	20.7	32.8	16.0	26.1	24.6	28.7	20.2	31.6	15.6	25.1	24.1	27.6	19.7	30.4	15.1	24.1	23.6	26.4	19.1	29.1	14.7
	29	27.8	27.8	29.9	24.3	33.0	19.8	27.0	27.0	28.9	23.8	31.8	19.4	26.1	26.1	27.7	23.3	30.6	18.9	25.2	25.2	26.6	22.8	29.2	18.3
5778	24	27.3	22.3	30.2	17.5	33.1	12.4	26.3	21.8	29.0	17.1	31.8	11.9	25.3	21.2	27.9	16.6	30.5	11.4	24.2	20.7	26.7	16.1	29.1	11.0
	27	27.6	26.2	30.2	21.4	33.3	16.5	26.6	25.7	29.1	20.9	32.1	16.0	25.6	25.2	28.0	20.4	30.8	15.6	24.5	24.5	26.8	19.9	29.5	15.1
	29	28.6	28.6	30.4	25.3	33.5	20.6	27.8	27.8	29.3	24.8	32.3	20.1	26.9	26.9	28.2	24.3	30.9	19.5	25.9	25.9	27.0	23.8	29.6	19.0
32	30.1	30.1	30.7	29.3	33.6	24.4	29.2	29.2	29.6	28.8	32.3	23.9	28.3	28.3	28.5	28.3	31.1	23.4	27.4	27.4	27.4	27.4	29.8	22.9	

Dry coil conditions. Total Gross Cooling Capacity (MBh) shown to the left is not applicable. In this case the Sensible Heat Capacity (SHC) is the total capacity.

All capacities shown are gross and have not considered indoor fan heat.  
 To obtain net cooling capacities subtract indoor fan heat.  
 TGC = Total Gross Cooling Capacity  
 SHC = Sensible Heat Capacity





# Performance Data

# System

**Table PD-5 – Gross Cooling Capacities (MBh) TTA100A Condensing Unit with TWE100A Air Handler**

**(I-P)**

		Ambient Temperature (°F)																																			
		85						95						105						115																	
CFM	Enter. Dry Bulb (°F)	Entering Wet Bulb (°F)																																			
		61						67						73						61						67						73					
		TGC	SHC	TGC	SHC	TGC	SHC	TGC	SHC	TGC	SHC	TGC	SHC	TGC	SHC	TGC	SHC	TGC	SHC	TGC	SHC	TGC	SHC	TGC	SHC	TGC	SHC	TGC	SHC	TGC	SHC						
3025	75	102.0	77.6	112.8	67.2	124.5	46.0	98.2	75.7	108.7	65.5	119.9	44.4	94.3	73.6	104.4	63.8	115.1	42.7	90.2	71.5	99.9	62.0	110.1	41.0	90.2	71.5	99.9	62.0	110.1	41.0						
	80	102.4	89.6	113.2	75.1	124.6	59.2	98.7	87.6	109.2	73.2	120.1	57.4	94.8	85.5	104.9	71.4	115.4	55.6	90.8	83.4	100.5	69.4	110.5	53.7	90.8	83.4	100.5	69.4	110.5	53.7						
	85	103.6	101.9	113.4	87.0	125.0	71.7	100.2	100.1	109.3	85.1	120.5	69.9	96.5	96.5	105.1	83.1	115.9	68.1	93.1	93.1	100.7	81.0	111.1	66.3	93.1	93.1	100.7	81.0	111.1	66.3						
	90	107.8	107.8	113.8	98.9	125.4	84.1	104.7	104.7	109.8	97.0	120.9	82.4	101.5	101.5	105.6	95.0	116.3	80.6	98.1	98.1	101.3	93.0	111.3	78.2	98.1	98.1	101.3	93.0	111.3	78.2						
3350	75	104.1	80.8	115.1	64.6	126.7	46.8	100.3	78.8	110.8	62.8	121.9	45.2	96.2	76.7	106.3	60.9	116.9	43.5	92.0	74.5	101.7	58.9	111.7	41.7	92.0	74.5	101.7	58.9	111.7	41.7						
	80	104.6	93.8	115.5	78.2	126.9	60.9	100.8	91.8	111.3	76.3	122.2	59.1	96.9	89.7	106.5	74.0	117.4	57.3	92.8	87.6	102.0	71.9	112.4	55.4	92.8	87.6	102.0	71.9	112.4	55.4						
	85	106.1	106.1	115.7	90.9	127.3	74.5	102.9	102.9	111.5	89.0	122.7	72.7	99.6	99.6	107.1	86.9	117.9	70.9	96.1	96.1	102.6	84.8	113.0	69.0	96.1	96.1	102.6	84.8	113.0	69.0						
	90	111.5	111.5	116.2	103.9	127.7	88.0	108.3	108.3	112.1	102.0	122.8	85.8	104.9	104.9	107.8	100.0	118.1	83.8	101.3	101.3	103.4	98.0	113.2	81.8	101.3	101.3	103.4	98.0	113.2	81.8						
3675	75	106.0	83.8	116.9	66.6	128.5	47.7	102.0	81.8	112.5	64.7	123.5	46.0	97.8	79.7	107.9	62.8	118.4	44.3	93.5	77.5	103.2	60.8	113.0	42.4	93.5	77.5	103.2	60.8	113.0	42.4						
	80	106.6	97.8	117.4	81.1	128.8	62.6	102.7	95.8	112.7	78.8	124.0	60.8	98.7	93.8	108.2	76.7	119.0	58.9	94.5	91.6	103.6	74.6	113.9	57.0	94.5	91.6	103.6	74.6	113.9	57.0						
	85	109.1	109.1	117.6	94.7	129.3	77.2	105.8	105.8	113.3	92.7	124.5	75.4	102.4	102.4	108.8	90.6	119.6	73.5	98.7	98.7	104.2	88.5	114.5	71.6	98.7	98.7	104.2	88.5	114.5	71.6						
	90	114.7	114.7	118.3	108.7	129.4	91.1	111.3	111.3	114.1	106.8	124.7	89.2	107.8	107.8	109.8	104.8	119.9	87.2	104.0	104.0	105.4	102.7	114.8	85.2	104.0	104.0	105.4	102.7	114.8	85.2						
4000	75	107.6	86.7	118.5	68.4	130.0	48.6	103.5	84.6	114.0	66.5	124.9	46.7	99.3	82.5	109.3	64.5	119.6	44.8	94.8	80.2	104.5	62.6	114.2	42.9	94.8	80.2	104.5	62.6	114.2	42.9						
	80	108.4	101.7	118.7	83.4	130.4	64.1	104.5	99.7	114.3	81.4	125.5	62.3	100.4	97.6	109.7	79.3	120.4	60.5	96.2	95.5	104.9	77.1	115.2	58.6	96.2	95.5	104.9	77.1	115.2	58.6						
	85	111.8	111.8	119.3	98.2	130.9	79.7	108.4	108.4	114.9	96.2	126.1	77.9	104.8	104.8	110.3	94.1	121.1	76.1	101.1	101.1	105.6	92.0	115.5	73.6	101.1	101.1	105.6	92.0	115.5	73.6						
	90	117.6	117.6	120.2	113.3	131.2	94.5	114.1	114.1	116.0	111.4	126.4	92.5	110.4	110.4	111.6	109.4	121.4	90.5	106.5	106.5	106.6	106.6	116.3	88.4	106.5	106.5	106.6	106.6	116.3	88.4						

Dry coil conditions. Total Gross Cooling Capacity (MBh) shown to the left is not applicable. In this case the Sensible Heat Capacity (SHC) is the total capacity.

All capacities shown are gross and have not considered indoor fan heat.  
 To obtain net cooling capacities subtract indoor fan heat.  
 TGC = Total Gross Cooling Capacity  
 SHC = Sensible Heat Capacity

**Table PD-5 – Gross Cooling Capacities (kW) TTA100A Condensing Unit with TWE100A Air Handler**

**(SI)**

		Ambient Temperature (°C)																																			
		29.4						35.0						40.6						46.1																	
m³/h	Enter. Dry Bulb (°C)	Entering Wet Bulb (°C)																																			
		16.1						19.4						22.8						16.1						19.4						22.8					
		TGC	SHC	TGC	SHC	TGC	SHC	TGC	SHC	TGC	SHC	TGC	SHC	TGC	SHC	TGC	SHC	TGC	SHC	TGC	SHC	TGC	SHC	TGC	SHC	TGC	SHC	TGC	SHC	TGC	SHC						
5141	24	29.9	22.7	33.0	19.7	36.4	13.5	28.8	22.2	31.8	19.2	35.1	13.0	27.6	21.6	30.6	18.7	33.7	12.5	26.4	20.9	29.2	18.1	32.2	12.0	26.4	20.9	29.2	18.1	32.2	12.0						
	27	30.0	26.2	33.2	22.0	36.5	17.3	28.9	25.6	32.0	21.4	35.2	16.8	27.8	25.0	30.7	20.9	33.8	16.3	26.6	24.4	29.4	20.3	32.4	15.7	26.6	24.4	29.4	20.3	32.4	15.7						
	29	30.3	29.8	33.2	25.5	36.6	21.0	29.3	29.3	32.0	24.9	35.3	20.5	28.2	28.2	30.8	24.3	33.9	19.9	27.3	27.3	29.5	23.7	32.5	19.4	27.3	27.3	29.5	23.7	32.5	19.4						
	32	31.6	31.6	33.3	29.0	36.7	24.6	30.7	30.7	32.1	28.4	35.4	24.1	29.7	29.7	30.9	27.8	34.1	23.6	28.7	28.7	29.7	27.2	32.6	22.9	28.7	28.7	29.7	27.2	32.6	22.9						
5692	24	30.5	23.7	33.7	18.9	37.1	13.7	29.4	23.1	32.4	18.4	35.7	13.2	28.2	22.5	31.1	17.8	34.2	12.7	26.9	21.8	29.8	17.3	32.7	12.2	26.9	21.8	29.8	17.3	32.7	12.2						
	27	30.6	27.5	33.8	22.9	37.2	17.8	29.5	26.9	32.6	22.3	35.8	17.3	28.4	26.3	31.2	21.7	34.4	16.8	27.2	25.7	29.9	21.1	32.9	16.2	27.2	25.7	29.9	21.1	32.9	16.2						
	29	31.1	31.1	33.9	26.6	37.3	21.8	30.1	30.1	32.7	26.0	35.9	21.3	29.2	29.2	31.4	25.5	34.5	20.8	28.1	28.1	30.0	24.8	33.1	20.2	28.1	28.1	30.0	24.8	33.1	20.2						
	32	32.6	32.6	34.0	30.4	37.4	25.8	31.7	31.7	32.8	29.9	36.0	25.1	30.7	30.7	31.6	29.3	34.6	24.5	29.7	29.7	30.3	28.7	33.1	23.9	29.7	29.7	30.3	28.7	33.1	23.9						
6242	24	31.0	24.5	34.2	19.5	37.6	14.0	29.9	24.0	32.9	18.9	36.2	13.5	28.6	23.3	31.6	18.4	34.7	13.0	27.4	22.7	30.2	17.8	33.1	12.4	27.4	22.7	30.2	17.8	33.1	12.4						
	27	31.2	28.6	34.4	23.7	37.7	18.3	30.1	28.1	33.0	23.1	36.3	17.8	28.9	27.5	31.7	22.5	34.9	17.3	27.7	26.8	30.3	21.8	33.4	16.7	27.7	26.8	30.3	21.8	33.4	16.7						
	29	31.9	31.9	34.4	27.7	37.9	22.6	31.0	31.0	33.2	27.1	36.5	22.1	30.0	30.0	31.9	26.5	35.0	21.5	28.9	28.9	30.5	25.9	33.5	21.0	28.9	28.9	30.5	25.9	33.5	21.0						
	32	33.6	33.6	34.6	31.8	37.9	26.7	32.6	32.6	33.4	31.3	36.5	26.1	31.6	31.6	32.1	30.7	35.1	25.5	30.5	30.5	30.9	30.1	33.6	24.9	30.5	30.5	30.9	30.1	33.6	24.9						
6797	24	31.5	25.4	34.7	20.0	38.1	14.2	30.3	24.8	33.4	19.5	36.6	13.7	29.1	24.2	32.0	18.9	35.0	13.1	27.8	23.5	30.6	18.3	33.4	12.5	27.8	23.5	30.6	18.3	33.4	12.5						
	27	31.7	29.8	34.8	24.4	38.2	18.8	30.6	29.2	33.5	23.8	36.8	18.3	29.4	28.6	32.1	23.2	35.3	17.7	28.2	28.0	30.7	22.6	33.7	17.1	28.2	28.0	30.7	22.6	33.7	17.1						
	29	32.7	32.7	34.9	28.8	38.3	23.3	31.7	31.7	33.6	28.2	36.9	22.8	30.7	30.7	32.3	27.6	35.4	22.3	29.6	29.6	30.9	26.9	33.8	21.5	29.6	29.6	30.9	26.9	33.8	21.5						
	32	34.4	34.4	35.2	33.2	38.4	27.7	33.4	33.4	34.0	32.6	37.0	27.1	32.3	32.3	32.7	32.0	35.5	26.5	31.2	31.2	31.2	31.2	34.0	25.9	31.2	31.2	31.2	31.2	34.0	25.9						

Dry coil conditions. Total Gross Cooling Capacity (MBh) shown to the left is not applicable. In this case the Sensible Heat Capacity (SHC) is the total capacity.

All capacities shown are gross and have not considered indoor fan heat.  
 To obtain net cooling capacities subtract indoor fan heat.  
 TGC = Total Gross Cooling Capacity  
 SHC = Sensible Heat Capacity



# Performance Data System

**Table PD-6 — Gross Cooling Capacities (MBh) TTA100B Condensing Unit with TWE100B Air Handler (I-P)**

		Ambient Temperature (°F)																							
		85						95						105						115					
		Enter. Dry Bulb		Entering Wet Bulb (°F)																					
CFM	(°F)	61		67		73		61		67		73		61		67		73		61		67		73	
Airflow	(°F)	TGC	SHC	TGC	SHC	TGC	SHC	TGC	SHC	TGC	SHC	TGC	SHC	TGC	SHC	TGC	SHC	TGC	SHC	TGC	SHC	TGC	SHC	TGC	SHC
3000	75	94.9	74.4	105.3	63.8	116.4	42.9	90.0	72.0	100.1	61.7	110.7	40.9	84.9	69.5	94.6	59.5	104.8	38.8	79.6	67.0	88.9	57.3	98.6	36.6
	80	95.1	86.5	105.5	71.4	116.4	55.6	90.4	84.2	100.3	69.0	110.7	53.4	85.5	81.9	94.8	66.6	104.8	51.1	80.5	79.5	89.0	64.2	98.6	48.7
	85	97.0	97.0	105.6	83.4	116.6	67.8	93.0	93.0	100.3	81.1	110.9	65.6	88.8	88.8	94.8	78.7	104.9	63.3	84.5	84.5	89.1	76.2	98.7	60.9
	90	102.0	102.0	105.9	95.4	116.8	80.0	97.9	97.9	100.8	93.1	111.1	77.7	93.6	93.6	95.5	90.8	105.1	75.4	89.1	89.1	90.1	88.5	98.8	73.0
3325	75	96.7	77.6	107.3	61.1	118.3	43.7	91.7	75.2	101.9	58.7	112.5	41.7	86.5	72.7	96.3	56.3	106.4	39.4	81.0	70.2	90.4	53.8	100.1	37.1
	80	97.3	90.9	107.5	74.4	118.4	57.3	92.4	88.6	102.1	72.1	112.6	55.0	87.5	86.3	96.4	69.6	106.5	52.7	82.2	82.2	90.5	67.1	100.1	50.3
	85	100.1	100.1	107.6	87.4	118.6	70.6	96.0	96.0	102.2	85.0	112.8	68.3	91.7	91.7	96.5	82.6	106.6	65.9	87.1	87.1	90.6	80.1	100.2	63.5
	90	105.4	105.4	108.2	100.4	118.8	83.8	101.1	101.1	103.0	98.2	112.9	81.4	96.6	96.6	97.6	95.9	106.7	78.9	91.9	91.9	91.9	91.9	100.3	76.4
3675	75	98.5	81.0	109.0	70.3	120.0	44.8	93.3	78.5	103.5	68.1	114.0	42.5	87.9	76.0	97.7	65.8	107.8	40.2	82.4	73.5	91.7	63.1	101.3	38.4
	80	99.3	95.4	109.3	77.5	120.2	59.0	94.4	93.1	103.7	75.1	114.2	56.7	89.1	89.1	97.8	72.6	107.9	54.4	84.5	84.5	91.8	70.0	101.4	52.0
	85	103.1	103.1	109.5	91.4	120.4	73.4	98.8	98.8	103.9	89.0	114.4	71.1	94.3	94.3	98.1	86.6	108.1	68.7	89.5	89.5	92.2	84.2	101.6	66.3
	90	108.5	108.5	110.4	105.6	120.6	87.3	104.1	104.1	105.1	103.4	114.5	85.0	99.4	99.4	99.3	99.3	108.2	82.6	94.5	94.5	94.4	94.4	101.7	80.1
4000	75	99.9	83.9	110.5	64.9	121.4	45.2	94.6	81.4	104.8	62.5	115.3	42.9	89.1	78.9	98.9	60.0	109.0	40.5	83.5	76.4	92.8	57.5	102.4	38.2
	80	101.1	99.4	110.6	80.1	121.6	60.5	95.7	95.7	104.9	77.7	115.5	58.2	91.2	91.2	99.0	75.2	109.1	55.9	86.4	86.4	92.8	72.7	102.5	53.5
	85	105.6	105.6	110.9	95.0	121.9	75.9	101.2	101.2	105.3	92.6	115.7	73.5	96.5	96.5	99.4	90.2	109.3	71.1	91.5	91.5	93.4	87.8	102.6	68.7
	90	111.2	111.2	112.3	110.3	122.1	90.6	106.6	106.6	106.5	106.5	115.9	88.2	101.7	101.7	101.6	101.6	109.4	85.8	96.6	96.6	96.6	96.6	102.7	83.4

Dry coil conditions. Total Gross Cooling Capacity (MBh) shown to the left is not applicable. In this case the Sensible Heat Capacity (SHC) is the total capacity.

All capacities shown are gross and have not considered indoor fan heat.

To obtain net cooling capacities subtract indoor fan heat.

TGC = Total Gross Cooling Capacity

SHC = Sensible Heat Capacity

**Table PD-6 — Gross Cooling Capacities (kW) TTA100B Condensing Unit with TWE100B Air Handler (SI)**

		Ambient Temperature (°C)																							
		29.4				35.0				40.6				46.1											
		Enter. Dry Bulb		Entering Wet Bulb (°C)																					
m³/h	(°C)	16.1		19.4		22.8		16.1		19.4		22.8		16.1		19.4		22.8							
Airflow	(°C)	TGC	SHC	TGC	SHC	TGC	SHC	TGC	SHC	TGC	SHC	TGC	SHC	TGC	SHC	TGC	SHC	TGC	SHC	TGC	SHC				
5098	23.9	27.8	21.8	30.9	18.7	34.1	12.6	26.4	21.1	29.3	18.1	32.4	12.0	24.9	20.4	27.7	17.4	30.7	11.4	23.3	19.6	26.1	16.8	28.9	10.7
	26.7	27.9	25.4	30.9	20.9	34.1	16.3	26.5	24.7	29.4	20.2	32.5	15.6	25.1	24.0	27.8	19.5	30.7	15.0	23.6	23.3	26.1	18.8	28.9	14.3
	29.4	28.4	28.4	31.0	24.5	34.2	19.9	27.3	27.3	29.4	23.8	32.5	19.2	26.0	26.0	27.8	23.1	30.8	18.5	24.8	24.8	26.1	22.3	28.9	17.8
	32.2	29.9	29.9	31.1	28.0	34.2	23.4	28.7	28.7	29.5	27.3	32.6	22.8	27.4	27.4	28.0	26.6	30.8	22.1	26.1	26.1	26.4	25.9	29.0	21.4
5648	23.9	28.4	22.8	31.5	17.9	34.7	12.8	26.9	22.0	29.9	17.2	33.0	12.2	25.4	21.3	28.2	16.5	31.2	11.6	23.7	20.6	26.5	15.8	29.3	10.9
	26.7	28.5	26.6	31.5	21.8	34.7	16.8	27.1	26.0	29.9	21.1	33.0	16.1	25.6	25.3	28.3	20.4	31.2	15.5	24.1	24.1	26.5	19.7	29.3	14.8
	29.4	29.4	29.4	31.5	25.6	34.8	20.7	28.1	28.1	30.0	24.9	33.0	20.0	26.9	26.9	28.3	24.2	31.2	19.3	25.5	25.5	26.6	23.5	29.4	18.6
	32.2	30.9	30.9	31.7	29.4	34.8	24.5	29.6	29.6	30.2	28.8	33.1	23.9	28.3	28.3	28.6	28.1	31.3	23.1	26.9	26.9	26.9	26.9	29.4	22.4
6246	23.9	28.9	23.7	32.0	20.6	35.2	13.1	27.4	23.0	30.3	20.0	33.4	12.5	25.8	22.3	28.6	19.3	31.6	11.8	24.1	21.5	26.9	18.5	29.7	11.3
	26.7	29.1	28.0	32.0	22.7	35.2	17.3	27.7	27.3	30.4	22.0	33.5	16.6	26.1	26.1	28.7	21.3	31.6	15.9	24.8	24.8	26.9	20.5	29.7	15.2
	29.4	30.2	30.2	32.1	26.8	35.3	21.5	29.0	29.0	30.4	26.1	33.5	20.8	27.6	27.6	28.8	25.4	31.7	20.1	26.2	26.2	27.0	24.7	29.8	19.4
	32.2	31.8	31.8	32.4	31.0	35.3	25.6	30.5	30.5	30.8	30.3	33.6	24.9	29.1	29.1	29.1	29.1	31.7	24.2	27.7	27.7	27.7	27.7	29.8	23.5
6797	23.9	29.3	24.6	32.4	19.0	35.6	13.2	27.7	23.9	30.7	18.3	33.8	12.6	26.1	23.1	29.0	17.6	31.9	11.9	24.5	22.4	27.2	16.9	30.0	11.2
	26.7	29.6	29.1	32.4	23.5	35.6	17.7	28.1	28.1	30.8	22.8	33.8	17.1	26.7	26.7	29.0	22.0	32.0	16.4	25.3	25.3	27.2	21.3	30.0	15.7
	29.4	31.0	31.0	32.5	27.8	35.7	22.2	29.7	29.7	30.9	27.1	33.9	21.6	28.3	28.3	29.1	26.4	32.0	20.9	26.8	26.8	27.4	25.7	30.1	20.1
	32.2	32.6	32.6	32.9	32.3	35.8	26.5	31.2	31.2	31.2	31.2	34.0	25.9	29.8	29.8	29.8	29.8	32.1	25.2	28.3	28.3	28.3	28.3	30.1	24.4

Dry coil conditions. Total Gross Cooling Capacity (MBh) shown to the left is not applicable. In this case the Sensible Heat Capacity (SHC) is the total capacity.

All capacities shown are gross and have not considered indoor fan heat.

To obtain net cooling capacities subtract indoor fan heat.

TGC = Total Gross Cooling Capacity

SHC = Sensible Heat Capacity



# Performance Data

# System

**Table PD-7 — Gross Cooling Capacities (MBh) - Both Compressors - TTA100C Condensing Unit with TWE100A Air Handler (I-P)**

CFM		Ambient Temperature (°F)																													
		85						95						105						115											
		Enter. Dry Bulb (°F)		61		67		73		61		67		73		61		67		73		61		67		73					
Airflow		TGC	SHC	TGC	SHC	TGC	SHC	TGC	SHC	TGC	SHC	TGC	SHC	TGC	SHC	TGC	SHC	TGC	SHC	TGC	SHC	TGC	SHC	TGC	SHC	TGC	SHC	TGC	SHC	TGC	SHC
3000	75	99.7	78.1	110.4	66.8	121.8	45.0	95.7	76.1	106.1	65.1	117.1	43.3	91.5	74.0	101.4	63.3	112.1	41.6	87.0	71.7	96.5	61.4	106.8	39.8	87.9	84.7	97.0	69.4	107.0	52.9
	80	100.2	90.9	110.7	75.3	121.9	58.6	96.3	88.9	106.4	73.5	117.2	56.8	92.2	86.8	101.8	71.5	112.3	54.9	87.9	84.7	97.0	69.4	107.0	52.9	87.9	84.7	97.0	69.4	107.0	52.9
	85	102.1	102.1	110.9	88.1	122.2	71.8	98.8	98.8	106.6	86.1	117.5	70.0	95.3	95.3	102.0	84.1	112.6	68.1	91.6	91.6	97.2	81.9	107.4	66.1	91.6	91.6	97.2	81.9	107.4	66.1
	90	107.3	107.3	111.4	100.9	122.4	85.0	104.0	104.0	107.2	99.0	117.7	83.2	100.4	100.4	102.8	97.0	112.7	81.0	96.6	96.6	98.2	94.9	107.5	79.0	96.6	96.6	98.2	94.9	107.5	79.0
3325	75	101.7	81.6	112.5	64.3	123.9	45.8	97.6	79.5	108.1	62.4	119.0	44.1	93.2	77.3	103.3	60.4	113.8	42.3	88.6	75.1	98.2	58.3	108.4	40.3	88.6	75.1	98.2	58.3	108.4	40.3
	80	102.4	95.6	112.8	78.7	124.0	60.4	98.4	93.6	108.4	76.8	119.1	58.6	94.2	91.5	103.4	74.4	114.0	56.7	89.9	89.3	98.5	72.3	108.6	54.7	89.9	89.3	98.5	72.3	108.6	54.7
	85	105.4	105.4	113.0	92.4	124.3	74.8	102.0	102.0	108.6	90.4	119.4	73.0	98.4	98.4	103.9	88.3	114.3	71.1	94.5	94.5	98.9	86.1	109.0	69.1	94.5	94.5	98.9	86.1	109.0	69.1
	90	110.9	110.9	113.7	106.4	124.5	89.1	107.4	107.4	109.5	104.5	119.5	86.9	103.7	103.7	105.0	102.5	114.5	84.9	99.7	99.7	99.8	99.8	109.2	82.9	99.7	99.7	99.8	99.8	109.2	82.9
3650	75	103.6	85.1	114.2	73.6	125.6	46.8	99.3	83.0	109.6	71.2	120.6	45.0	94.8	80.8	104.8	69.3	115.3	43.1	90.0	78.5	99.6	67.3	109.7	41.6	90.0	78.5	99.6	67.3	109.7	41.6
	80	104.5	100.4	114.5	81.8	125.8	62.3	100.5	98.4	109.9	79.8	120.8	60.4	95.7	95.7	105.1	77.6	115.6	58.5	91.8	91.8	100.0	75.4	110.1	56.5	91.8	91.8	100.0	75.4	110.1	56.5
	85	108.6	108.6	114.8	96.8	126.1	77.9	105.0	105.0	110.3	94.8	121.1	76.0	101.2	101.2	105.6	92.7	115.9	74.1	97.2	97.2	100.6	90.5	110.4	72.1	97.2	97.2	100.6	90.5	110.4	72.1
	90	114.2	114.2	116.0	112.2	126.3	93.0	110.5	110.5	111.7	110.2	121.3	91.0	106.7	106.7	106.8	106.8	116.1	89.0	102.6	102.6	102.7	102.7	110.7	86.9	102.6	102.6	102.7	102.7	110.7	86.9
4000	75	105.0	88.3	115.7	68.4	127.1	47.3	100.6	86.2	111.1	66.5	121.9	45.4	96.0	83.9	106.1	64.5	116.5	43.4	91.3	81.6	100.8	62.4	110.8	41.5	91.3	81.6	100.8	62.4	110.8	41.5
	80	106.3	104.8	115.9	84.6	127.3	64.0	101.8	101.8	111.3	82.6	122.1	62.1	97.9	97.9	106.4	80.5	116.8	60.2	93.8	93.8	101.2	78.2	111.2	58.2	93.8	93.8	101.2	78.2	111.2	58.2
	85	111.2	111.2	116.3	100.7	127.6	80.6	107.5	107.5	111.8	98.7	122.5	78.8	103.6	103.6	107.0	96.6	117.2	76.8	99.4	99.4	101.9	94.4	111.4	74.4	99.4	99.4	101.9	94.4	111.4	74.4
	90	116.9	116.9	117.9	117.3	127.8	96.6	113.2	113.2	113.3	113.3	122.7	94.7	109.2	109.2	109.2	109.2	117.4	92.6	104.9	104.9	105.0	105.0	111.9	90.5	104.9	104.9	105.0	105.0	111.9	90.5

Dry coil conditions. Total Gross Cooling Capacity (MBh) shown to the left is not applicable. In this case the Sensible Heat Capacity (SHC) is the total capacity.

All capacities shown are gross and have not considered indoor fan heat.  
 To obtain net cooling capacities subtract indoor fan heat.  
 TGC = Total Gross Cooling Capacity  
 SHC = Sensible Heat Capacity

**Table PD-7 — Gross Cooling Capacities (kW) - Both Compressors - TTA100C Condensing Unit with TWE100A Air Handler (SI)**

m³/h		Ambient Temperature (°C)																													
		29.4						35.0						40.6						46.1											
		Enter. Dry Bulb (°C)		16.1		19.4		22.8		16.1		19.4		22.8		16.1		19.4		22.8		16.1		19.4		22.8					
Airflow		TGC	SHC	TGC	SHC	TGC	SHC	TGC	SHC	TGC	SHC	TGC	SHC	TGC	SHC	TGC	SHC	TGC	SHC	TGC	SHC	TGC	SHC	TGC	SHC	TGC	SHC	TGC	SHC	TGC	SHC
5098	24	29.2	22.9	32.3	19.6	35.7	13.2	28.0	22.3	31.1	19.1	34.3	12.7	26.8	21.7	29.7	18.5	32.8	12.2	25.5	21.0	28.3	18.0	31.3	11.6	25.5	21.0	28.3	18.0	31.3	11.6
	27	29.3	26.6	32.4	22.1	35.7	17.1	28.2	26.0	31.2	21.5	34.3	16.6	27.0	25.4	29.8	20.9	32.9	16.1	25.7	24.8	28.4	20.3	31.3	15.5	25.7	24.8	28.4	20.3	31.3	15.5
	29	29.9	29.9	32.5	25.8	35.8	21.0	28.9	28.9	31.2	25.2	34.4	20.5	27.9	27.9	29.9	24.6	33.0	19.9	26.8	26.8	28.5	24.0	31.4	19.4	26.8	26.8	28.5	24.0	31.4	19.4
	32	31.4	31.4	32.6	29.6	35.8	24.9	30.5	30.5	31.4	29.0	34.5	24.4	29.4	29.4	30.1	28.4	33.0	23.7	28.3	28.3	28.8	27.8	31.5	23.1	28.3	28.3	28.8	27.8	31.5	23.1
5648	24	29.8	23.9	32.9	18.8	36.3	13.4	28.6	23.3	31.6	18.3	34.8	12.9	27.3	22.6	30.2	17.7	33.3	12.4	25.9	22.0	28.8	17.1	31.7	11.8	25.9	22.0	28.8	17.1	31.7	11.8
	27	30.0	28.0	33.0	23.0	36.3	17.7	28.8	27.4	31.7	22.5	34.9	17.2	27.6	26.8	30.3	21.8	33.4	16.6	26.3	26.2	28.8	21.2	31.8	16.0	26.3	26.2	28.8	21.2	31.8	16.0
	29	30.9	30.9	33.1	27.0	36.4	21.9	29.9	29.9	31.8	26.5	35.0	21.4	28.8	28.8	30.4	25.9	33.5	20.8	27.7	27.7	29.0	25.2	31.9	20.2	27.7	27.7	29.0	25.2	31.9	20.2
	32	32.5	32.5	33.3	31.2	36.5	26.1	31.4	31.4	32.1	30.6	35.0	25.5	30.4	30.4	30.8	30.0	33.5	24.9	29.2	29.2	29.2	29.2	32.0	24.3	29.2	29.2	29.2	29.2	32.0	24.3
6203	24	30.3	24.9	33.4	21.6	36.8	13.7	29.1	24.3	32.1	20.8	35.3	13.2	27.8	23.7	30.7	20.3	33.7	12.6	26.4	23.0	29.2	19.7	32.1	12.2	26.4	23.0	29.2	19.7	32.1	12.2
	27	30.6	29.4	33.5	23.9	36.8	18.2	29.4	28.8	32.2	23.4	35.4	17.7	28.0	28.0	30.8	22.7	33.8	17.1	26.9	26.9	29.3	22.1	32.2	16.6	26.9	26.9	29.3	22.1	32.2	16.6
	29	31.8	31.8	33.6	28.3	36.9	22.8	30.7	30.7	32.3	27.7	35.5	22.3	29.6	29.6	30.9	27.1	33.9	21.7	28.4	28.4	29.4	26.5	32.3	21.1	28.4	28.4	29.4	26.5	32.3	21.1
	32	33.4	33.4	34.0	32.8	37.0	27.2	32.4	32.4	32.7	32.3	35.5	26.7	31.2	31.2	31.3	31.3	34.0	26.1	30.0	30.0	30.1	30.1	32.4	25.4	30.0	30.0	30.1	30.1	32.4	25.4
6797	24	30.7	25.8	33.9	20.0	37.2	13.8	29.5	25.2	32.5	19.5	35.7	13.3	28.1	24.6	31.1	18.9	34.1	12.7	26.7	23.9	29.5	18.3	32.4	12.1	26.7	23.9	29.5	18.3	32.4	12.1
	27	31.1	30.7	33.9	24.8	37.3	18.7	29.8	29.8	32.6	24.2	35.8	18.2	28.7	28.7	31.1	23.6	34.2	17.6	27.5	27.5	29.6	22.9	32.6	17.0	27.5	27.5	29.6	22.9	32.6	17.0
	29	32.6	32.6	34.1	29.5	37.4	23.6	31.5	31.5	32.7	28.9	35.9	23.1	30.3	30.3	31.3	28.3	34.3	22.5	29.1	29.1	29.8	27.6	32.6	21.8	29.1	29.1	29.8	27.6	32.6	21.8
	32	34.2	34.2	34.5	34.3	37.4	28.3	33.1	33.1	33.2	33.2	35.9	27.7	32.0	32.0	32.0	32.0	34.4	27.1	30.7	30.7	30.7	30.7	32.8	26.5	30.7	30.7	30.7	30.7	32.8	26.5

Dry coil conditions. Total Gross Cooling Capacity (kW) shown to the left is not applicable. In this case the Sensible Heat Capacity (SHC) is the total capacity.

All capacities shown are gross and have not considered indoor fan heat.  
 To obtain net cooling capacities subtract indoor fan heat.  
 TGC = Total Gross Cooling Capacity  
 SHC = Sensible Heat Capacity



# Performance Data System

**Table PD-8 — Gross Cooling Capacities (MBh) - Single Compressor - TTA100C Condensing Unit with TWE100A Air Handler (I-P)**

		Ambient Temperature (°F)																							
		85						95						105						115					
		Enter. Dry Bulb (°F)		Entering Wet Bulb (°F)																					
61				67		73		61		67		73		61		67		73		61		67		73	
CFM	Airflow	TGC	SHC	TGC	SHC	TGC	SHC	TGC	SHC	TGC	SHC	TGC	SHC	TGC	SHC	TGC	SHC	TGC	SHC	TGC	SHC	TGC	SHC	TGC	SHC
3000	75	62.7	60.3	68.8	49.8	75.3	29.4	60.1	59.0	65.9	48.6	72.1	28.4	57.3	57.3	62.8	47.4	68.7	27.3	54.8	54.8	59.7	46.1	65.2	26.2
	80	65.8	65.8	69.1	57.4	75.9	41.9	63.5	63.5	66.2	56.2	72.6	40.5	61.0	61.0	63.2	54.9	69.4	39.3	58.5	58.5	60.2	53.6	66.0	37.9
	85	69.8	69.8	69.8	69.8	76.2	54.4	67.3	67.3	67.4	67.4	73.1	53.2	64.8	64.8	64.9	64.9	69.8	52.0	62.1	62.1	62.2	62.2	66.5	50.7
3325	75	63.7	63.5	69.6	46.4	76.1	29.2	61.0	61.0	66.6	45.1	72.8	28.1	58.6	58.6	63.5	43.8	69.3	26.9	56.0	56.0	60.3	42.5	65.7	25.8
	80	67.4	67.4	69.9	60.3	76.6	43.2	65.0	65.0	67.0	59.1	73.4	42.0	62.4	62.4	64.0	57.8	70.1	40.7	59.8	59.8	60.9	56.5	66.6	39.4
	85	71.5	71.5	71.5	71.5	77.0	57.0	69.0	69.0	69.0	69.0	73.8	55.8	66.3	66.3	66.4	66.4	70.5	54.6	63.5	63.5	63.6	63.6	67.1	53.4
3650	75	64.8	64.8	70.3	55.6	76.7	31.0	62.3	62.3	67.3	54.3	73.3	30.0	59.8	59.8	64.1	45.6	69.8	28.9	57.1	57.1	60.9	44.2	66.1	27.8
	80	68.9	68.9	70.7	63.3	77.3	44.7	66.3	66.3	67.8	62.1	74.1	43.5	63.7	63.7	64.7	60.8	70.7	42.2	61.0	61.0	61.6	59.5	67.2	40.8
	85	73.0	73.0	73.1	73.1	77.7	59.8	70.4	70.4	70.5	70.5	74.5	58.6	67.7	67.7	67.8	67.8	71.1	57.3	64.8	64.8	64.9	64.9	67.7	56.1
4000	75	65.8	65.8	70.8	49.8	77.2	30.2	63.3	63.3	67.8	48.5	73.7	29.1	60.7	60.7	64.6	47.2	70.1	27.9	58.0	58.0	61.3	45.7	66.4	26.7
	80	70.1	70.1	71.4	66.0	77.9	46.1	67.5	67.5	68.4	64.8	74.7	45.9	64.7	64.7	65.3	63.5	71.2	43.5	61.9	61.9	62.2	62.2	67.6	42.1
	85	74.3	74.3	74.4	74.4	78.3	62.2	71.6	71.6	71.7	71.7	75.0	61.0	68.8	68.8	68.9	68.9	71.6	59.8	65.9	65.9	66.0	66.0	68.2	58.5
90	78.6	78.6	78.7	78.7	79.2	78.7	75.8	75.8	75.9	75.9	75.9	75.9	72.9	72.9	73.0	73.0	73.1	73.1	69.9	69.9	70.0	70.0	70.0	70.0	

Dry coil conditions. Total Gross Cooling Capacity (MBh) shown to the left is not applicable. In this case the Sensible Heat Capacity (SHC) is the total capacity.

All capacities shown are gross and have not considered indoor fan heat.

To obtain net cooling capacities subtract indoor fan heat.

TGC = Total Gross Cooling Capacity

SHC = Sensible Heat Capacity

**Table PD-8 — Gross Cooling Capacities (kW) - Single Compressor - TTA100C Condensing Unit with TWE100A Air Handler (SI)**

		Ambient Temperature (°C)																							
		29.4				35.0				40.6				46.1											
		Enter. Dry Bulb (°C)		Entering Wet Bulb (°C)																					
16.1				19.4		22.8		16.1		19.4		22.8		16.1		19.4		22.8							
m³/h	Airflow	TGC	SHC	TGC	SHC	TGC	SHC	TGC	SHC	TGC	SHC	TGC	SHC	TGC	SHC	TGC	SHC	TGC	SHC	TGC	SHC	TGC	SHC		
5098	24	18.4	17.6	20.1	14.6	22.1	8.6	17.6	17.3	19.3	14.2	21.1	8.3	16.8	16.8	18.4	13.9	20.1	8.0	16.0	16.0	17.5	13.5	19.1	7.7
	27	19.3	19.3	20.2	16.8	22.2	12.3	18.6	18.6	19.4	16.4	21.3	11.9	17.9	17.9	18.5	16.1	20.3	11.5	17.1	17.1	17.6	15.7	19.3	11.1
	29	20.4	20.4	20.4	20.4	22.3	15.9	19.7	19.7	19.7	19.7	21.4	15.6	19.0	19.0	19.0	19.0	20.4	15.2	18.2	18.2	18.2	18.2	19.5	14.9
	32	21.6	21.6	21.6	21.6	22.4	19.7	20.9	20.9	20.9	20.9	21.5	19.4	20.1	20.1	20.1	20.1	20.6	19.0	19.3	19.3	19.3	19.3	19.6	18.7
5648	24	18.7	18.6	20.4	13.6	22.3	8.5	17.9	17.9	19.5	13.2	21.3	8.2	17.2	17.2	18.6	12.8	20.3	7.9	16.4	16.4	17.7	12.4	19.2	7.5
	27	19.7	19.7	20.5	17.7	22.4	12.6	19.0	19.0	19.6	17.3	21.5	12.3	18.3	18.3	18.7	16.9	20.5	11.9	17.5	17.5	17.8	16.5	19.5	11.5
	29	20.9	20.9	20.9	20.9	22.6	16.7	20.2	20.2	20.2	20.2	21.6	16.4	19.4	19.4	19.4	19.4	20.7	16.0	18.6	18.6	18.6	18.6	19.7	15.6
	32	22.1	22.1	22.1	22.1	22.7	20.8	21.4	21.4	21.4	21.4	21.8	20.5	20.6	20.6	20.6	20.6	20.8	20.1	19.7	19.7	19.8	19.8	19.9	19.8
6203	24	19.0	19.0	20.6	16.3	22.4	9.1	18.2	18.2	19.7	15.9	21.5	8.8	17.5	17.5	18.8	13.4	20.4	8.5	16.7	16.7	17.8	12.9	19.3	8.1
	27	20.2	20.2	20.7	18.5	22.6	13.1	19.4	19.4	19.8	18.2	21.7	12.7	18.6	18.6	18.9	17.8	20.7	12.4	17.8	17.8	18.0	17.4	19.7	12.0
	29	21.4	21.4	21.4	21.4	22.8	17.5	20.6	20.6	20.6	20.6	21.8	17.1	19.8	19.8	19.8	19.8	20.8	16.8	19.0	19.0	19.0	19.0	19.8	16.4
	32	22.6	22.6	22.6	22.6	23.0	22.0	21.8	21.8	21.8	21.8	22.0	21.6	21.0	21.0	21.0	21.0	21.0	21.0	20.1	20.1	20.2	20.2	20.2	20.2
6797	24	19.3	19.3	20.7	14.6	22.6	8.8	18.5	18.5	19.9	14.2	21.6	8.5	17.8	17.8	18.9	13.8	20.5	8.2	17.0	17.0	18.0	13.4	19.4	7.8
	27	20.5	20.5	20.9	19.3	22.8	13.5	19.8	19.8	20.0	19.0	21.9	13.4	19.0	19.0	19.1	18.6	20.8	12.7	18.1	18.1	18.2	18.2	19.8	12.3
	29	21.8	21.8	21.8	21.8	22.9	18.2	21.0	21.0	21.0	21.0	22.0	17.9	20.2	20.2	20.2	20.2	21.0	17.5	19.3	19.3	19.3	19.3	20.0	17.1
	32	23.0	23.0	23.0	23.0	23.2	23.0	22.2	22.2	22.2	22.2	22.2	22.2	21.4	21.4	21.4	21.4	21.4	21.4	20.5	20.5	20.5	20.5	20.5	20.5

Dry coil conditions. Total Gross Cooling Capacity (MBh) shown to the left is not applicable. In this case the Sensible Heat Capacity (SHC) is the total capacity.

All capacities shown are gross and have not considered indoor fan heat.

To obtain net cooling capacities subtract indoor fan heat.

TGC = Total Gross Cooling Capacity

SHC = Sensible Heat Capacity



# Performance Data System

**Table PD-9 — Gross Cooling Capacities (MBh) TTA125B Condensing Unit with TWE100B Air Handler (I-P)**

CFM		Ambient Temperature (°F)																															
		85								95								105								115							
		Enter. Dry Bulb (°F)		Entering Wet Bulb (°F)																													
Airflow	61	67	73	61	67	73	61	67	73	61	67	73	61	67	73	61	67	73	61	67	73	61	67	73									
3000	75	108.2	79.4	117.8	61.3	124.3	42.2	100.3	76.1	109.3	58.1	115.4	39.2	92.3	72.8	100.8	54.9	106.5	36.1	84.4	69.5	92.3	51.7	97.6	33.0								
	80	108.2	93.1	117.8	75.0	124.3	55.9	100.3	89.8	109.3	71.8	115.4	52.8	92.3	86.5	100.8	68.5	106.5	49.7	84.4	82.7	92.3	65.3	97.6	46.7								
	85	108.2	105.3	117.8	88.6	124.3	69.5	100.3	99.4	109.3	85.4	115.4	66.5	93.1	93.1	100.8	82.2	106.5	63.5	86.9	86.9	92.3	79.0	97.6	60.3								
	90	110.2	110.2	117.8	102.2	124.3	83.2	103.9	103.9	109.3	99.0	115.4	80.2	97.4	97.4	100.8	96.0	106.5	77.0	90.8	90.8	92.7	92.7	97.6	74.0								
3325	75	110.0	83.1	119.6	64.1	126.3	44.1	101.8	79.6	111.0	60.7	117.2	41.0	93.8	76.1	102.4	57.4	108.2	37.7	85.8	72.6	93.7	54.1	99.2	34.5								
	80	110.0	97.4	119.6	78.4	126.3	58.5	101.8	93.9	111.0	75.1	117.2	55.2	93.8	90.4	102.4	71.7	108.2	52.0	86.5	86.5	93.7	68.3	99.2	48.9								
	85	110.1	110.1	119.6	92.7	126.3	72.7	104.0	104.0	111.0	89.3	117.2	69.6	97.4	97.4	102.4	85.9	108.2	66.4	90.9	90.9	93.7	82.7	99.2	63.1								
	90	115.3	115.3	119.6	106.9	126.3	87.0	108.7	108.7	111.0	103.6	117.2	83.9	101.9	101.9	102.4	100.4	108.2	80.6	95.0	95.0	96.9	96.9	99.2	77.4								
3675	75	111.8	87.0	121.7	67.1	128.4	46.2	103.6	83.3	112.9	63.6	119.2	43.0	95.4	79.7	104.1	60.2	110.1	39.5	87.2	76.1	95.3	56.6	100.8	36.1								
	80	111.8	102.0	121.7	82.1	128.4	61.3	103.6	98.3	112.9	78.6	119.2	57.9	95.4	94.7	104.1	75.1	110.1	54.5	90.6	90.6	95.3	71.6	100.8	51.2								
	85	115.4	115.4	121.7	97.1	128.4	76.2	108.9	108.9	112.9	93.5	119.2	72.9	102.0	102.0	104.1	90.0	110.1	69.5	95.2	95.2	95.3	86.6	100.8	66.2								
	90	120.8	120.8	121.7	112.0	128.4	91.1	111.6	111.6	112.9	108.5	119.2	87.8	103.2	103.2	105.1	105.1	110.1	84.4	99.0	99.0	99.2	99.2	100.8	81.0								
4000	75	113.5	90.7	123.5	69.9	130.4	48.2	105.2	86.8	114.6	66.3	121.0	44.8	96.9	83.1	105.7	62.7	111.8	41.2	88.6	79.3	96.8	59.0	102.4	37.7								
	80	113.5	106.2	123.5	85.6	130.4	63.8	105.2	102.5	114.6	81.9	121.0	60.3	98.7	98.7	105.7	78.2	111.8	56.8	94.4	94.4	96.8	74.6	102.4	53.4								
	85	120.2	120.2	123.5	101.2	130.4	79.4	113.5	113.5	114.6	97.5	121.0	75.9	104.8	104.8	105.7	93.8	111.8	72.4	96.1	96.1	96.8	90.2	102.4	68.9								
	90	123.1	123.1	123.5	116.7	130.4	94.9	113.5	113.5	114.6	113.0	121.0	91.5	107.6	107.6	109.5	109.5	111.8	87.9	99.8	99.8	101.5	101.5	102.4	84.4								

Dry coil conditions. Total Gross Cooling Capacity (MBh) shown to the left is not applicable. In this case the Sensible Heat Capacity (SHC) is the total capacity.

All capacities shown are gross and have not considered indoor fan heat.  
 To obtain net cooling capacities subtract indoor fan heat.  
 TGC = Total Gross Cooling Capacity  
 SHC = Sensible Heat Capacity

**Table PD-9 — Gross Cooling Capacities (kW) TTA125B Condensing Unit with TWE100B Air Handler (SI)**

m³/h		Ambient Temperature (°C)																							
		29.4				35.0				40.6				46.1											
		Enter. Dry Bulb (°C)		Entering Wet Bulb (°C)																					
Airflow	16.1	19.4	22.8	16.1	19.4	22.8	16.1	19.4	22.8	16.1	19.4	22.8	16.1	19.4	22.8										
5098	23.9	31.7	23.3	34.5	18.0	36.4	12.4	29.4	22.3	32.0	17.0	33.8	11.5	27.0	21.3	29.5	16.1	31.2	10.6	24.7	20.4	27.0	15.1	28.6	9.7
	26.7	31.7	27.3	34.5	22.0	36.4	16.4	29.4	26.3	32.0	21.0	33.8	15.5	27.0	25.3	29.5	20.1	31.2	14.6	24.7	24.2	27.0	19.1	28.6	13.7
	29.4	31.7	30.9	34.5	26.0	36.4	20.4	29.4	29.1	32.0	25.0	33.8	19.5	27.3	27.3	29.5	24.1	31.2	18.6	25.5	25.5	27.0	23.1	28.6	17.7
	32.2	32.3	32.3	34.5	29.9	36.4	24.4	30.4	30.4	32.0	29.0	33.8	23.5	28.5	28.5	29.5	28.1	31.2	22.6	26.6	26.6	27.2	27.2	28.6	21.7
5648	23.9	32.2	24.3	35.0	18.8	37.0	12.9	29.8	23.3	32.5	17.8	34.3	12.0	27.5	22.3	30.0	16.8	31.7	11.0	25.1	21.3	27.5	15.9	29.1	10.1
	26.7	32.2	28.5	35.0	23.0	37.0	17.1	29.8	27.5	32.5	22.0	34.3	16.2	27.5	26.5	30.0	21.0	31.7	15.2	25.3	25.3	27.5	20.0	29.1	14.3
	29.4	32.3	32.3	35.0	27.2	37.0	21.3	30.5	30.5	32.5	26.2	34.3	20.4	28.5	28.5	30.0	25.2	31.7	19.5	26.6	26.6	27.5	24.2	29.1	18.5
	32.2	33.8	33.8	35.0	31.3	37.0	25.5	31.8	31.8	32.5	30.4	34.3	24.6	29.9	29.9	30.0	29.4	31.7	23.6	27.8	27.8	28.4	28.4	29.1	22.7
6246	23.9	32.8	25.5	35.7	19.7	37.6	13.5	30.4	24.4	33.1	18.6	34.9	12.6	28.0	23.4	30.5	17.6	32.3	11.6	25.5	22.3	27.9	16.6	29.5	10.6
	26.7	32.8	29.9	35.7	24.1	37.6	18.0	30.4	28.8	33.1	23.0	34.9	17.0	28.0	27.7	30.5	22.0	32.3	16.0	26.5	26.5	27.9	21.0	29.5	15.0
	29.4	33.8	33.8	35.7	28.5	37.6	22.3	31.9	31.9	33.1	27.4	34.9	21.4	29.9	29.9	30.5	26.4	32.3	20.4	27.9	27.9	27.9	25.4	29.5	19.4
	32.2	35.4	35.4	35.7	32.8	37.6	26.7	32.7	32.7	33.1	31.8	34.9	25.7	30.2	30.2	30.8	30.8	32.3	24.7	29.0	29.0	29.1	29.1	29.5	23.7
6797	23.9	33.3	26.6	36.2	20.5	38.2	14.1	30.8	25.4	33.6	19.4	35.5	13.1	28.4	24.3	31.0	18.4	32.8	12.1	26.0	23.2	28.4	17.3	30.0	11.0
	26.7	33.3	31.1	36.2	25.1	38.2	18.7	30.8	30.0	33.6	24.0	35.5	17.7	28.8	28.9	31.0	22.9	32.8	16.6	27.7	27.7	28.4	21.9	30.0	15.6
	29.4	35.2	35.2	36.2	29.7	38.2	23.3	33.3	33.3	33.6	28.6	35.5	22.2	30.7	30.7	31.0	27.5	32.8	21.2	28.2	28.2	28.4	26.4	30.0	20.2
	32.2	36.1	36.1	36.2	34.2	38.2	27.8	33.3	33.3	33.6	33.1	35.5	26.8	31.5	31.5	32.1	32.1	32.8	25.8	29.2	29.2	29.7	29.7	30.0	24.7

Dry coil conditions. Total Gross Cooling Capacity (MBh) shown to the left is not applicable. In this case the Sensible Heat Capacity (SHC) is the total capacity.

All capacities shown are gross and have not considered indoor fan heat.  
 To obtain net cooling capacities subtract indoor fan heat.  
 TGC = Total Gross Cooling Capacity  
 SHC = Sensible Heat Capacity



# Performance Data System

**Table PD-10 — Gross Cooling Capacities (MBh) TTA125B Condensing Unit with TWE155B Air Handler (I-P)**

CFM		Ambient Temperature (°F)																													
		85						95						105						115											
		Enter. Dry Bulb (°F)		Entering Wet Bulb (°F)				Enter. Dry Bulb (°F)		Entering Wet Bulb (°F)				Enter. Dry Bulb (°F)		Entering Wet Bulb (°F)				Enter. Dry Bulb (°F)		Entering Wet Bulb (°F)									
Airflow	TGC	SHC	TGC	SHC	TGC	SHC	TGC	SHC	TGC	SHC	TGC	SHC	TGC	SHC	TGC	SHC	TGC	SHC	TGC	SHC	TGC	SHC	TGC	SHC	TGC	SHC	TGC	SHC	TGC	SHC	
3750	75	120.8	96.6	132.7	73.8	141.1	49.7	113.8	93.7	124.9	70.8	132.7	46.7	106.3	90.5	116.6	67.6	123.9	43.6	98.8	87.4	108.3	64.6	115.0	40.6	104.9	104.9	108.3	82.2	115.0	58.3
	80	120.8	114.3	132.7	91.4	141.1	67.4	113.8	111.4	124.9	88.5	132.7	64.5	108.3	108.3	116.6	85.4	123.9	61.3	104.9	104.9	108.3	82.2	115.0	58.3	104.9	104.9	108.3	82.2	115.0	58.3
	85	126.8	126.8	132.7	109.2	141.1	85.1	119.6	119.6	124.9	106.2	132.7	82.1	112.4	112.4	116.6	103.0	123.9	79.1	105.0	105.0	108.3	100.0	115.0	76.0	110.0	110.0	111.2	111.2	115.0	93.6
	90	127.4	127.4	132.7	126.9	141.1	102.8	123.1	123.1	124.9	123.9	132.7	100.0	118.9	118.9	119.7	119.7	123.9	96.7	110.0	110.0	111.2	111.2	115.0	93.6	110.0	110.0	111.2	111.2	115.0	93.6
4200	75	122.7	101.2	134.9	77.3	143.4	52.0	115.6	98.1	127.0	74.1	134.9	49.0	108.0	94.8	118.5	70.8	125.9	45.7	100.4	91.5	110.1	67.6	116.9	42.5	100.4	91.5	110.1	67.6	116.9	42.5
	80	122.7	119.7	134.9	95.7	143.4	70.6	116.6	116.6	127.0	92.7	134.9	67.5	113.4	113.4	118.5	89.4	125.9	64.2	109.9	109.9	110.1	86.1	116.9	61.1	110.0	110.0	110.1	104.7	116.9	79.5
	85	132.8	132.8	134.9	114.3	143.4	89.1	125.3	125.3	127.0	111.2	134.9	86.0	117.7	117.7	118.5	107.9	125.9	82.9	110.0	110.0	110.1	104.7	116.9	79.5	110.0	110.0	110.1	104.7	116.9	79.5
	90	133.4	133.4	134.9	132.8	143.4	107.7	128.9	128.9	129.8	129.8	134.9	104.7	124.5	124.5	125.3	125.3	125.9	101.3	115.2	115.2	116.4	116.4	116.9	98.0	115.2	115.2	116.4	116.4	116.9	98.0
4600	75	124.7	105.7	137.1	80.8	145.6	54.3	117.5	102.5	129.0	77.4	137.1	51.2	109.7	99.1	120.4	74.0	127.9	47.7	102.0	95.7	111.8	70.7	118.7	44.4	102.0	95.7	111.8	70.7	118.7	44.4
	80	125.1	125.1	137.1	100.1	145.6	73.8	121.9	121.9	129.0	96.8	137.1	70.5	118.5	118.5	120.4	93.4	127.9	67.1	111.1	111.1	111.8	90.0	118.7	63.8	111.1	111.1	111.8	90.0	118.7	63.8
	85	136.9	136.9	137.1	119.5	145.6	93.1	128.7	128.7	129.0	116.2	137.1	89.9	119.9	119.9	120.4	112.7	127.9	86.6	111.5	111.5	111.8	109.4	118.7	83.1	111.5	111.5	111.8	109.4	118.7	83.1
	90	137.9	137.9	138.8	138.8	145.6	112.5	134.7	134.7	135.6	135.6	137.1	109.5	127.4	127.4	127.8	127.8	127.9	105.8	117.0	117.0	117.7	117.7	118.7	102.5	117.0	117.0	117.7	117.7	118.7	102.5
5000	75	126.7	110.3	139.2	84.2	147.9	56.7	119.3	106.9	131.0	80.8	139.2	53.4	111.4	103.3	122.3	77.2	129.9	49.8	103.6	99.8	113.6	73.7	120.6	46.3	103.6	99.8	113.6	73.7	120.6	46.3
	80	130.5	130.5	139.2	104.4	147.9	76.9	127.1	127.1	131.0	101.0	139.2	73.6	121.9	121.9	122.3	97.4	129.9	70.0	112.7	112.7	113.6	93.8	120.6	66.6	112.7	112.7	113.6	93.8	120.6	66.6
	85	138.6	138.6	139.2	124.6	147.9	97.1	130.3	130.3	131.0	121.2	139.2	93.7	122.2	122.2	122.3	117.6	129.9	90.3	113.9	113.9	114.1	114.1	120.6	86.7	113.9	113.9	114.1	114.1	120.6	86.7
	90	144.1	144.1	144.8	144.8	147.9	117.4	138.6	138.6	138.7	138.7	139.2	114.2	128.8	128.8	129.4	129.4	129.9	110.4	119.6	119.6	120.2	120.2	120.6	106.9	119.6	119.6	120.2	120.2	120.6	106.9

Dry coil conditions. Total Gross Cooling Capacity (MBh) shown to the left is not applicable. In this case the Sensible Heat Capacity (SHC) is the total capacity.

All capacities shown are gross and have not considered indoor fan heat.  
 To obtain net cooling capacities subtract indoor fan heat.  
 TGC = Total Gross Cooling Capacity  
 SHC = Sensible Heat Capacity

**Table PD-10 — Gross Cooling Capacities (kW) TTA125B Condensing Unit with TWE155B Air Handler (SI)**

m³/h		Ambient Temperature (°C)																													
		29.4				35.0				40.6				46.1																	
		Enter. Dry Bulb (°C)		Entering Wet Bulb (°C)		Enter. Dry Bulb (°C)		Entering Wet Bulb (°C)		Enter. Dry Bulb (°C)		Entering Wet Bulb (°C)		Enter. Dry Bulb (°C)		Entering Wet Bulb (°C)															
Airflow	TGC	SHC	TGC	SHC	TGC	SHC	TGC	SHC	TGC	SHC	TGC	SHC	TGC	SHC	TGC	SHC	TGC	SHC	TGC	SHC	TGC	SHC									
6372	23.9	35.4	28.3	38.9	21.6	41.3	14.6	33.3	27.5	36.6	20.7	38.9	13.7	31.1	26.5	34.2	19.8	36.3	12.8	28.9	25.6	31.7	18.9	33.7	11.9	30.7	30.7	31.7	24.1	33.7	17.1
	26.7	35.4	33.5	38.9	26.8	41.3	19.7	33.3	32.6	36.6	25.9	38.9	18.9	31.7	31.7	34.2	25.0	36.3	18.0	30.7	30.7	31.7	24.1	33.7	17.1	30.7	30.7	31.7	24.1	33.7	17.1
	29.4	37.2	37.2	38.9	32.0	41.3	24.9	35.0	35.0	36.6	31.1	38.9	24.1	32.9	32.9	34.2	30.2	36.3	23.2	30.8	30.8	31.7	29.3	33.7	22.3	30.8	30.8	31.7	29.3	33.7	22.3
	32.2	37.3	37.3	38.9	37.2	41.3	30.1	36.1	36.1	36.6	36.3	38.9	29.3	34.8	34.8	35.1	35.1	36.3	28.3	32.2	32.2	32.6	32.6	33.7	27.4	32.2	32.2	32.6	32.6	33.7	27.4
7135	23.9	36.0	29.7	39.5	22.6	42.0	15.2	33.9	28.7	37.2	21.7	39.5	14.4	31.6	27.8	34.7	20.7	36.9	13.4	29.4	26.8	32.3	19.8	34.3	12.5	29.4	26.8	32.3	19.8	34.3	12.5
	26.7	36.0	35.1	39.5	28.0	42.0	20.7	34.2	34.2	37.2	27.2	39.5	19.8	33.2	33.2	34.7	26.2	36.9	18.8	32.2	32.2	32.3	25.2	34.3	17.9	32.2	32.2	32.3	25.2	34.3	17.9
	29.4	38.9	38.9	39.5	33.5	42.0	26.1	36.7	36.7	37.2	32.6	39.5	25.2	34.5	34.5	34.7	31.6	36.9	24.3	32.2	32.2	32.3	30.7	34.3	23.3	32.2	32.2	32.3	30.7	34.3	23.3
	32.2	39.1	39.1	39.5	38.9	42.0	31.6	37.8	37.8	38.0	38.0	39.5	30.7	36.5	36.5	36.7	36.7	36.9	29.7	33.8	33.8	34.1	34.1	34.3	28.7	33.8	33.8	34.1	34.1	34.3	28.7
7816	23.9	36.5	31.0	40.2	23.7	42.7	15.9	34.4	30.0	37.8	22.7	40.2	15.0	32.1	29.0	35.3	21.7	37.5	14.0	29.9	28.0	32.8	20.7	34.8	13.0	29.9	28.0	32.8	20.7	34.8	13.0
	26.7	36.7	36.7	40.2	29.3	42.7	21.6	35.7	35.7	37.8	28.4	40.2	20.7	34.7	34.7	35.3	27.4	37.5	19.7	32.6	32.6	32.8	26.4	34.8	18.7	32.6	32.6	32.8	26.4	34.8	18.7
	29.4	40.1	40.1	40.2	35.0	42.7	27.3	37.7	37.7	37.8	34.0	40.2	26.3	35.1	35.1	35.3	33.0	37.5	25.4	32.7	32.7	32.8	32.1	34.8	24.3	32.7	32.7	32.8	32.1	34.8	24.3
	32.2	40.4	40.4	40.7	40.7	42.7	33.0	39.5	39.5	39.7	39.7	40.2	32.1	37.3	37.3	37.4	37.4	37.5	31.0	34.3	34.3	34.5	34.5	34.8	30.0	34.3	34.3	34.5	34.5	34.8	30.0
8496	23.9	37.1	32.3	40.8	24.7	43.3	16.6	35.0	31.3	38.4	23.7	40.8	15.6	32.6	30.3	35.8	22.6	38.1	14.6	30.4	29.2	33.3	21.6	35.3	13.6	30.4	29.2	33.3	21.6	35.3	13.6
	26.7	38.2	38.2	40.8	30.6	43.3	22.5	37.2	37.2	38.4	29.6	40.8	21.6	35.7	35.7	35.8	28.5	38.1	20.5	33.0	33.0	33.3	27.5	35.3	19.5	33.0	33.0	33.3	27.5	35.3	19.5
	29.4	40.6	40.6	40.8	36.5	43.3	28.5	38.2	38.2	38.4	35.5	40.8	27.5	35.8	35.8	35.8	34.5	38.1	26.5	33.4	33.4	33.4	33.4	35.3	25.4	33.4	33.4	33.4	33.4	35.3	25.4
	32.2	42.2	42.2	42.4	42.4	43.3	34.4	40.6	40.6	40.6	40.6	40.8	33.5	37.7	37.7	37.9	37.9	38.1	32.3	35.0	35.0	35.2	35.2	35.3	31.3	35.0	35.0	35.2	35.2	35.3	31.3

Dry coil conditions. Total Gross Cooling Capacity (MBh) shown to the left is not applicable. In this case the Sensible Heat Capacity (SHC) is the total capacity.

All capacities shown are gross and have not considered indoor fan heat.  
 To obtain net cooling capacities subtract indoor fan heat.  
 TGC = Total Gross Cooling Capacity  
 SHC = Sensible Heat Capacity



# Performance Data

# System

**Table PD-11 — Gross Cooling Capacities (MBh) TTA155B Condensing Unit with TWE155B Air Handler (I-P)**

		Ambient Temperature (°F)																							
		85						95						105						115					
CFM	Enter. Dry Bulb (°F)	Entering Wet Bulb (°F)																							
		61		67		73		61		67		73		61		67		73		61		67		73	
Airflow	(°F)	TGC	SHC	TGC	SHC	TGC	SHC	TGC	SHC	TGC	SHC	TGC	SHC	TGC	SHC	TGC	SHC	TGC	SHC	TGC	SHC	TGC	SHC	TGC	SHC
4500	75	153.6	120.6	169.3	101.0	185.5	68.8	148.1	117.8	163.0	98.5	178.1	66.3	141.7	114.5	155.8	95.6	169.8	63.4	134.4	110.7	147.7	92.3	160.6	60.3
	80	154.5	140.6	169.7	116.3	186.6	90.6	149.2	137.8	163.5	113.4	179.4	87.8	142.9	134.6	156.4	110.1	171.4	84.9	135.9	131.0	148.4	106.4	162.6	81.6
	85	157.8	157.8	170.7	136.1	187.6	111.5	153.2	153.2	164.5	133.3	180.4	108.8	147.8	147.8	157.4	130.0	172.5	105.8	141.6	141.6	149.4	126.3	163.2	101.6
	90	165.9	165.9	171.6	156.3	188.0	131.2	161.1	161.1	165.6	153.4	180.8	128.2	155.4	155.4	158.7	150.2	173.0	125.0	149.1	149.1	151.1	146.7	164.5	121.4
5000	75	156.7	126.1	172.4	99.7	188.2	69.9	151.0	123.2	165.9	97.0	180.6	67.3	144.4	119.8	158.4	93.9	172.1	64.4	136.8	116.0	149.3	89.6	162.7	61.2
	80	158.0	148.1	172.9	121.2	189.8	93.6	152.4	145.2	166.5	118.3	182.3	90.8	146.0	141.9	159.1	114.9	174.1	87.8	138.9	138.2	151.0	111.1	165.0	84.6
	85	163.0	163.0	173.9	143.0	190.9	116.5	158.2	158.2	167.5	140.0	182.7	112.8	152.4	152.4	160.1	136.6	174.6	109.5	145.9	145.9	152.0	132.9	165.8	105.8
	90	171.5	171.5	175.3	165.1	191.5	137.6	166.4	166.4	169.1	162.2	184.0	134.5	160.4	160.4	162.1	159.0	175.9	131.2	153.7	153.7	153.9	153.9	167.1	127.6
5500	75	159.4	131.3	174.9	103.1	190.6	71.2	153.5	128.3	168.2	100.3	182.7	68.5	146.6	124.8	159.8	96.2	173.9	65.5	138.9	120.9	151.3	92.3	164.3	62.3
	80	161.0	155.3	175.7	125.9	192.5	96.5	155.4	152.3	169.0	122.9	184.6	93.7	148.2	148.2	161.5	119.4	176.2	90.6	141.7	141.7	153.1	115.6	167.0	87.4
	85	167.6	167.6	176.6	149.5	193.0	120.1	162.5	162.5	170.0	146.5	185.3	117.0	156.5	156.5	162.5	143.1	177.0	113.6	149.7	149.7	154.3	139.3	168.0	109.9
	90	176.3	176.3	178.6	173.6	194.4	143.6	170.9	170.9	172.3	170.7	186.7	140.5	164.7	164.7	164.9	164.9	178.3	137.1	157.8	157.8	157.9	157.9	169.3	133.5
6000	75	161.6	136.3	177.1	106.2	192.5	72.4	155.5	133.2	169.5	102.4	184.4	69.6	148.5	129.7	161.7	98.8	175.4	66.5	140.6	125.7	153.6	96.9	165.6	63.1
	80	163.8	162.2	178.0	130.4	194.7	99.2	157.6	157.6	171.2	127.4	186.6	96.4	151.6	151.6	163.4	123.8	178.0	93.3	144.8	144.8	154.9	119.9	168.6	90.1
	85	171.7	171.7	179.1	155.8	195.5	124.2	166.3	166.3	172.3	152.7	187.6	121.0	160.0	160.0	164.7	149.3	179.0	117.5	153.0	153.0	156.3	145.5	169.9	113.8
	90	180.7	180.7	180.9	180.9	196.8	149.5	175.0	175.0	175.1	175.1	189.0	146.3	168.5	168.5	168.7	168.7	180.3	142.8	161.3	161.3	161.5	161.5	171.2	139.2

Dry coil conditions. Total Gross Cooling Capacity (MBh) shown to the left is not applicable. In this case the Sensible Heat Capacity (SHC) is the total capacity.

All capacities shown are gross and have not considered indoor fan heat.  
 To obtain net cooling capacities subtract indoor fan heat.  
 TGC = Total Gross Cooling Capacity  
 SHC = Sensible Heat Capacity

**Table PD-11 — Gross Cooling Capacities (kW) TTA155B Condensing Unit with TWE155B Air Handler (SI)**

		Ambient Temperature (°C)																							
		29.4						35.0						40.6						46.1					
m³/h	Enter. Dry Bulb (°C)	Entering Wet Bulb (°C)																							
		16.1		19.4		22.8		16.1		19.4		22.8		16.1		19.4		22.8		16.1		19.4		22.8	
Airflow	(°C)	TGC	SHC	TGC	SHC	TGC	SHC	TGC	SHC	TGC	SHC	TGC	SHC	TGC	SHC	TGC	SHC	TGC	SHC	TGC	SHC	TGC	SHC	TGC	SHC
7646	24	45.0	35.3	49.6	29.6	54.3	20.1	43.4	34.5	47.7	28.8	52.1	19.4	41.5	33.5	45.6	28.0	49.7	18.6	39.4	32.4	43.2	27.0	47.0	17.7
	27	45.2	41.2	49.7	34.0	54.6	26.5	43.7	40.4	47.9	33.2	52.5	25.7	41.8	39.4	45.8	32.2	50.2	24.8	39.8	38.3	43.5	31.1	47.6	23.9
	29	46.2	46.2	50.0	39.9	54.9	32.7	44.9	44.9	48.2	39.0	52.8	31.9	43.3	43.3	46.1	38.1	50.5	31.0	41.5	41.5	43.8	37.0	47.8	29.7
	32	48.6	48.6	50.2	45.8	55.0	38.4	47.2	47.2	48.5	44.9	52.9	37.5	45.5	45.5	46.5	44.0	50.7	36.6	43.7	43.7	44.2	42.9	48.2	35.6
8496	24	45.9	36.9	50.5	29.2	55.1	20.5	44.2	36.1	48.6	28.4	52.9	19.7	42.3	35.1	46.4	27.5	50.4	18.9	40.1	34.0	43.7	26.2	47.6	17.9
	27	46.3	43.4	50.6	35.5	55.6	27.4	44.6	42.5	48.8	34.6	53.4	26.6	42.8	41.6	46.6	33.6	51.0	25.7	40.7	40.5	44.2	32.5	48.3	24.8
	29	47.7	47.7	50.9	41.9	55.9	34.1	46.3	46.3	49.0	41.0	53.5	33.0	44.6	44.6	46.9	40.0	51.1	32.1	42.7	42.7	44.5	38.9	48.6	31.0
	32	50.2	50.2	51.3	48.3	56.1	40.3	48.7	48.7	49.5	47.5	53.9	39.4	47.0	47.0	47.5	46.5	51.5	38.4	45.0	45.0	45.1	45.1	48.9	37.4
9346	24	46.7	38.4	51.2	30.2	55.8	20.8	44.9	37.6	49.3	29.4	53.5	20.1	42.9	36.5	46.8	28.2	50.9	19.2	40.7	35.4	44.3	27.0	48.1	18.3
	27	47.1	45.5	51.4	36.9	56.3	28.3	45.5	44.6	49.5	36.0	54.1	27.4	43.4	43.4	47.3	35.0	51.6	26.5	41.5	41.5	44.8	33.9	48.9	25.6
	29	49.1	49.1	51.7	43.8	56.5	35.2	47.6	47.6	49.8	42.9	54.3	34.3	45.8	45.8	47.6	41.9	51.8	33.3	43.8	43.8	45.2	40.8	49.2	32.2
	32	51.6	51.6	52.3	50.8	56.9	42.1	50.0	50.0	50.4	50.0	54.7	41.1	48.2	48.2	48.3	48.3	52.2	40.1	46.2	46.2	46.2	46.2	49.6	39.1
10195	24	47.3	39.9	51.9	31.1	56.4	21.2	45.5	39.0	49.6	30.0	54.0	20.4	43.5	38.0	47.3	28.9	51.4	19.5	41.2	36.8	45.0	28.4	48.5	18.5
	27	48.0	47.5	52.1	38.2	57.0	29.1	46.1	46.1	50.1	37.3	54.6	28.2	44.4	44.4	47.9	36.3	52.1	27.3	42.4	42.4	45.3	35.1	49.4	26.4
	29	50.3	50.3	52.4	45.6	57.2	36.4	48.7	48.7	50.4	44.7	54.9	35.4	46.9	46.9	48.2	43.7	52.4	34.4	44.8	44.8	45.8	42.6	49.7	33.3
	32	52.9	52.9	53.0	53.0	57.6	43.8	51.2	51.2	51.3	51.3	55.3	42.8	49.3	49.3	49.4	49.4	52.8	41.8	47.2	47.2	47.3	47.3	50.1	40.7

Dry coil conditions. Total Gross Cooling Capacity (MBh) shown to the left is not applicable. In this case the Sensible Heat Capacity (SHC) is the total capacity.

All capacities shown are gross and have not considered indoor fan heat.  
 To obtain net cooling capacities subtract indoor fan heat.  
 TGC = Total Gross Cooling Capacity  
 SHC = Sensible Heat Capacity



# Performance Data System

**Table PD-12— Gross Cooling Capacities (MBh) TTA155B Condensing Unit with TWE200B Air Handler (I-P)**

		Ambient Temperature (°F)																							
		85						95						105						115					
CFM	Enter. Dry Bulb (°F)	Entering Wet Bulb (°F)																							
		61		67		73		61		67		73		61		67		73		61		67		73	
Airflow		TGC	SHC	TGC	SHC	TGC	SHC	TGC	SHC	TGC	SHC	TGC	SHC	TGC	SHC	TGC	SHC	TGC	SHC	TGC	SHC	TGC	SHC	TGC	SHC
4500	75	158.1	125.3	174.1	103.2	189.9	70.5	152.4	122.3	167.6	100.6	182.4	67.9	145.7	118.9	160.0	97.5	173.8	64.9	138.1	115.0	151.6	94.1	164.3	61.7
	80	159.2	146.5	174.5	120.6	191.6	93.5	153.6	143.6	168.1	117.6	184.2	90.7	147.0	140.2	160.7	114.1	175.9	87.7	139.7	136.5	152.4	110.3	166.9	84.4
	85	163.2	163.2	175.5	141.6	192.7	115.6	158.3	158.3	169.0	138.6	185.2	112.8	152.6	152.6	161.6	135.2	176.4	108.9	146.2	146.2	153.4	131.4	167.5	105.2
5000	75	171.5	171.5	176.6	162.9	193.1	136.3	166.4	166.4	170.3	160.0	185.7	133.2	160.5	160.5	163.2	156.7	177.6	129.9	153.9	153.9	155.3	153.1	168.8	126.2
	80	161.4	131.2	177.3	103.3	192.7	71.7	155.4	128.2	170.5	100.5	184.9	69.0	148.4	124.6	162.7	97.3	176.0	66.0	140.5	120.7	153.1	92.5	166.2	62.7
	85	162.8	154.7	177.8	125.9	194.8	96.8	157.0	151.7	171.1	122.9	187.1	94.0	150.3	148.2	163.5	119.3	178.6	90.9	142.7	142.7	155.0	115.4	169.3	87.6
5500	75	168.7	168.7	178.8	149.0	196.1	121.1	163.6	163.6	172.1	146.0	187.6	117.0	157.5	157.5	164.5	142.5	179.2	113.5	150.7	150.7	156.1	138.7	170.2	109.8
	80	177.4	177.4	180.4	172.6	196.7	143.2	172.0	172.0	174.0	169.6	188.8	140.0	165.8	165.8	166.8	166.3	180.5	136.6	158.8	158.8	159.0	159.0	171.5	133.0
	85	164.1	136.9	179.9	107.0	195.0	72.9	157.9	133.8	172.0	103.1	186.9	70.2	150.7	130.2	164.0	99.4	177.8	67.1	142.7	126.1	155.2	95.3	167.7	63.8
6000	75	166.0	162.5	180.6	131.1	197.5	99.9	160.1	159.5	173.7	127.9	189.5	97.1	153.2	153.2	165.8	124.3	180.7	94.0	146.4	146.4	157.1	120.4	171.2	90.7
	80	182.5	182.5	184.0	182.0	199.6	149.9	176.8	176.8	177.0	177.0	191.5	146.6	170.3	170.3	170.4	170.4	182.9	143.2	163.0	163.0	163.2	163.2	173.7	139.5
	85	166.3	142.4	181.3	109.2	196.8	74.1	160.0	139.2	174.1	106.0	188.5	71.3	152.7	135.5	165.9	102.2	179.1	68.2	144.5	131.4	156.9	98.0	168.8	64.8

Dry coil conditions. Total Gross Cooling Capacity (MBh) shown to the left is not applicable. In this case the Sensible Heat Capacity (SHC) is the total capacity.

All capacities shown are gross and have not considered indoor fan heat.  
 To obtain net cooling capacities subtract indoor fan heat.  
 TGC = Total Gross Cooling Capacity  
 SHC = Sensible Heat Capacity

**Table PD-12 – Gross Cooling Capacities (kW) TTA155B Condensing Unit with TWE200B Air Handler (SI)**

		Ambient Temperature (°C)																							
		29.4						35.0						40.6						46.1					
m³/h	Enter. Dry Bulb (°C)	Entering Wet Bulb (°C)																							
		16.1		19.4		22.8		16.1		19.4		22.8		16.1		19.4		22.8		16.1		19.4		22.8	
Airflow		TGC	SHC	TGC	SHC	TGC	SHC	TGC	SHC	TGC	SHC	TGC	SHC	TGC	SHC	TGC	SHC	TGC	SHC	TGC	SHC	TGC	SHC	TGC	SHC
7646	23.9	46.3	36.7	51.0	30.2	55.6	20.7	44.6	35.8	49.1	29.4	53.4	19.9	42.7	34.8	46.9	28.5	50.9	19.0	40.4	33.7	44.4	27.6	48.1	18.1
	26.7	46.6	42.9	51.1	35.3	56.1	27.4	45.0	42.0	49.2	34.4	53.9	26.6	43.1	41.1	47.0	33.4	51.5	25.7	40.9	40.0	44.6	32.3	48.9	24.7
	29.4	47.8	47.8	51.4	41.5	56.4	33.9	46.4	46.4	49.5	40.6	54.2	33.0	44.7	44.7	47.3	39.6	51.6	31.9	42.8	42.8	44.9	38.5	49.0	30.8
	32.2	50.2	50.2	51.7	47.7	56.5	39.9	48.7	48.7	49.9	46.8	54.4	39.0	47.0	47.0	47.8	45.9	52.0	38.0	45.1	45.1	45.5	44.8	49.4	37.0
8496	23.9	47.2	38.4	51.9	30.3	56.4	21.0	45.5	37.5	49.9	29.4	54.1	20.2	43.4	36.5	47.6	28.5	51.5	19.3	41.1	35.3	44.8	27.1	48.7	18.4
	26.7	47.7	45.3	52.1	36.9	57.0	28.3	46.0	44.4	50.1	36.0	54.8	27.5	44.0	43.4	47.9	34.9	52.3	26.6	41.8	41.8	45.4	33.8	49.6	25.7
	29.4	49.4	49.4	52.4	43.6	57.4	35.4	47.9	47.9	50.4	42.7	54.9	34.2	46.1	46.1	48.2	41.7	52.5	33.2	44.1	44.1	45.7	40.6	49.8	32.1
	32.2	51.9	51.9	52.8	50.5	57.6	41.9	50.4	50.4	50.9	49.7	55.3	41.0	48.5	48.5	48.8	48.7	52.9	40.0	46.5	46.5	46.6	46.6	50.2	38.9
9346	23.9	48.0	40.1	52.7	31.3	57.1	21.3	46.2	39.2	50.4	30.2	54.7	20.5	44.1	38.1	48.0	29.1	52.0	19.6	41.8	36.9	45.4	27.9	49.1	18.7
	26.7	48.6	47.6	52.9	38.4	57.8	29.3	46.9	46.7	50.9	37.5	55.5	28.4	44.9	44.9	48.6	36.4	52.9	27.5	42.9	42.9	46.0	35.2	50.1	26.5
	29.4	50.8	50.8	53.2	45.7	58.0	36.5	49.2	49.2	51.2	44.8	55.7	35.6	47.4	47.4	48.9	43.8	53.2	34.6	45.3	45.3	46.4	42.7	50.5	33.4
	32.2	53.4	53.4	53.9	53.3	58.4	43.9	51.8	51.8	51.8	51.8	56.1	42.9	49.9	49.9	49.9	49.9	53.6	41.9	47.7	47.7	47.8	47.8	50.9	40.8
10195	23.9	48.7	41.7	53.1	32.0	57.6	21.7	46.8	40.8	51.0	31.0	55.2	20.9	44.7	39.7	48.6	29.9	52.4	20.0	42.3	38.5	45.9	28.7	49.4	19.0
	26.7	49.3	49.3	53.6	39.8	58.5	30.1	47.7	47.7	51.5	38.9	56.1	29.3	45.9	45.9	49.1	37.8	53.4	28.4	43.8	43.8	46.5	36.6	50.6	27.4
	29.4	52.0	52.0	53.9	47.8	58.8	37.8	50.4	50.4	51.9	46.9	56.3	36.9	48.4	48.4	49.6	45.8	53.8	35.8	46.3	46.3	47.0	44.7	51.0	34.7
	32.2	54.8	54.8	54.8	54.8	59.2	45.8	53.0	53.0	53.1	53.1	56.8	44.8	51.0	51.0	51.1	51.1	54.2	43.8	48.8	48.8	48.9	48.9	51.4	42.7

Dry coil conditions. Total Gross Cooling Capacity (MBh) shown to the left is not applicable. In this case the Sensible Heat Capacity (SHC) is the total capacity.

All capacities shown are gross and have not considered indoor fan heat.  
 To obtain net cooling capacities subtract indoor fan heat.  
 TGC = Total Gross Cooling Capacity  
 SHC = Sensible Heat Capacity



# Performance Data

# System

**Table PD-13 — Gross Cooling Capacities (MBh) - Both Compressors - TTA155C Condensing Unit With TWE155B Air Handler (I-P)**

CFM		Ambient Temperature (°F)																							
		85						95						105						115					
		Enter. Dry Bulb		Entering Wet Bulb (°F)																					
Airflow		61		67		73		61		67		73		61		67		73		61		67		73	
		(°F)		TGC	SHC	TGC	SHC	TGC	SHC	TGC	SHC	TGC	SHC	TGC	SHC	TGC	SHC	TGC	SHC	TGC	SHC	TGC	SHC	TGC	SHC
4500	75	147.1	118.2	163.0	98.8	180.4	66.6	141.7	115.6	156.9	96.3	173.3	64.1	135.4	112.5	149.9	93.6	165.4	61.4	128.3	109.1	142.1	90.5	156.9	58.5
	80	147.9	138.6	163.3	113.9	180.5	87.8	142.7	136.0	157.2	111.3	173.4	85.1	136.7	133.1	150.1	108.1	165.5	82.2	130.0	129.8	142.3	104.8	157.1	79.1
	85	152.6	152.6	163.5	134.0	180.8	108.6	148.0	148.0	157.4	131.3	173.6	106.0	142.7	142.7	150.5	128.3	165.8	103.0	136.7	136.7	142.8	125.0	157.3	99.9
	90	160.5	160.5	164.5	154.5	180.9	129.2	155.8	155.8	158.6	151.9	173.8	126.4	150.3	150.3	152.0	149.0	166.0	123.3	144.1	144.1	144.3	144.3	157.6	120.1
5000	75	150.0	123.9	165.9	96.6	183.5	68.0	144.4	121.2	159.6	94.0	176.1	65.3	137.8	118.1	152.4	91.0	167.8	62.4	130.5	114.6	144.3	87.8	159.1	59.2
	80	151.2	146.4	166.1	119.0	183.6	90.8	145.9	143.8	159.8	116.3	176.2	88.1	139.4	139.4	152.6	113.2	168.0	85.1	133.2	133.2	144.6	109.8	159.3	82.0
	85	157.6	157.6	166.5	141.1	183.8	113.6	152.8	152.8	160.2	138.4	176.5	110.9	147.2	147.2	153.1	135.3	168.3	107.9	140.9	140.9	145.2	132.0	159.7	104.8
	90	165.9	165.9	168.1	163.7	184.0	135.8	160.9	160.9	162.1	161.1	176.7	133.0	155.1	155.1	155.2	155.2	168.6	129.9	148.6	148.6	148.7	148.7	159.9	126.6
5500	75	152.4	129.4	168.4	100.0	185.9	69.1	146.6	126.6	161.8	97.3	178.3	66.3	139.9	123.4	154.4	94.3	169.9	63.3	132.5	120.0	146.2	91.0	161.0	60.2
	80	154.3	153.9	168.6	124.0	186.1	93.7	148.6	148.6	162.0	121.2	178.5	91.0	143.0	143.0	154.7	118.1	170.0	87.9	136.6	136.6	146.5	114.7	161.2	84.8
	85	162.0	162.0	169.1	147.9	186.4	118.3	156.9	156.9	162.6	145.1	178.8	115.6	151.1	151.1	155.4	142.1	170.2	112.3	144.5	144.5	147.4	138.7	161.4	109.0
	90	170.7	170.7	170.9	170.9	186.6	142.1	165.3	165.3	165.4	165.4	179.1	139.3	159.2	159.2	159.4	159.4	170.7	136.1	152.5	152.5	152.7	161.9	132.8	
6000	75	154.4	134.6	170.5	103.1	188.0	70.0	148.5	131.8	163.7	100.4	180.3	67.2	141.7	128.6	156.1	97.4	171.6	64.2	134.2	125.1	147.7	94.1	162.5	61.0
	80	157.1	157.1	170.8	128.8	188.2	96.4	152.1	152.1	164.0	126.0	180.4	93.7	146.2	146.2	156.4	122.8	171.8	90.6	139.6	139.6	148.1	119.3	162.8	87.5
	85	165.9	165.9	171.5	154.6	188.6	122.9	160.6	160.6	164.8	151.7	180.6	119.8	154.5	154.5	157.5	148.6	172.1	116.6	147.7	147.7	149.5	149.3	163.1	113.2
	90	174.9	174.9	175.1	175.1	188.9	148.3	169.2	169.2	169.4	169.4	181.1	145.4	162.8	162.8	163.0	163.0	172.6	142.2	155.9	155.9	156.1	156.1	163.5	138.9

Dry coil conditions. Total Gross Cooling Capacity (MBh) shown to the left is not applicable. In this case the Sensible Heat Capacity (SHC) is the total capacity.

All capacities shown are gross and have not considered indoor fan heat.  
 To obtain net cooling capacities subtract indoor fan heat.  
 TGC = Total Gross Cooling Capacity  
 SHC = Sensible Heat Capacity

**Table PD-13 — Gross Cooling Capacities (kW) - Both Compressors - TTA155C Condensing Unit With TWE155B Air Handler (SI)**

m³/h		Ambient Temperature (°C)																							
		29.4						35.0						40.6						46.1					
		Enter. Dry Bulb		Entering Wet Bulb (°C)																					
Airflow		16.1		19.4		22.8		16.1		19.4		22.8		16.1		19.4		22.8		16.1		19.4		22.8	
		TGC	SHC	TGC	SHC	TGC	SHC	TGC	SHC	TGC	SHC	TGC	SHC	TGC	SHC	TGC	SHC	TGC	SHC	TGC	SHC	TGC	SHC	TGC	SHC
7646	24	43.1	34.6	47.7	28.9	52.8	19.5	41.5	33.8	45.9	28.2	50.7	18.8	39.7	32.9	43.9	27.4	48.4	18.0	37.6	31.9	41.6	26.5	45.9	17.1
	27	43.3	40.6	47.8	33.4	52.8	25.7	41.8	39.8	46.0	32.6	50.8	24.9	40.0	39.0	43.9	31.7	48.5	24.1	38.1	38.0	41.7	30.7	46.0	23.2
	29	44.7	44.7	47.9	39.2	52.9	31.8	43.3	43.3	46.1	38.5	50.8	31.0	41.8	41.8	44.1	37.6	48.5	30.2	40.0	40.0	41.8	36.6	46.1	29.3
	32	47.0	47.0	48.2	45.2	53.0	37.8	45.6	45.6	46.4	44.5	50.9	37.0	44.0	44.0	44.5	43.6	48.6	36.1	42.2	42.2	42.3	42.3	46.1	35.2
8496	24	43.9	36.3	48.6	28.3	53.7	19.9	42.3	35.5	46.7	27.5	51.6	19.1	40.4	34.6	44.6	26.7	49.1	18.3	38.2	33.6	42.3	25.7	46.6	17.3
	27	44.3	42.9	48.6	34.9	53.7	26.6	42.7	42.1	46.8	34.1	51.6	25.8	40.8	40.8	44.7	33.2	49.2	24.9	39.0	39.0	42.3	32.2	46.7	24.0
	29	46.2	46.2	48.8	41.3	53.8	33.3	44.7	44.7	46.9	40.5	51.7	32.5	43.1	43.1	44.8	39.6	49.3	31.6	41.3	41.3	42.5	38.6	46.7	30.7
	32	48.6	48.6	49.2	47.9	53.9	39.8	47.1	47.1	47.5	47.2	51.7	38.9	45.4	45.4	45.4	45.4	49.4	38.0	43.5	43.5	43.6	43.6	46.8	37.1
9346	24	44.6	37.9	49.3	29.3	54.4	20.2	42.9	37.1	47.4	28.5	52.2	19.4	41.0	36.1	45.2	27.6	49.7	18.5	38.8	35.1	42.8	26.6	47.1	17.6
	27	45.2	45.1	49.4	36.3	54.5	27.4	43.5	43.5	47.4	35.5	52.3	26.6	41.9	41.9	45.3	34.6	49.8	25.7	40.0	40.0	42.9	33.6	47.2	24.8
	29	47.4	47.4	49.5	43.3	54.6	34.6	46.0	46.0	47.6	42.5	52.4	33.8	44.2	44.2	45.5	41.6	49.8	32.9	42.3	42.3	43.2	40.6	47.3	31.9
	32	50.0	50.0	50.0	50.0	54.6	41.6	48.4	48.4	48.4	48.4	52.4	40.8	46.6	46.6	46.7	46.7	50.0	39.9	44.6	44.6	44.7	44.7	47.4	38.9
10195	24	45.2	39.4	49.9	30.2	55.1	20.5	43.5	38.6	47.9	29.4	52.8	19.7	41.5	37.7	45.7	28.5	50.2	18.8	39.3	36.6	43.3	27.5	47.6	17.9
	27	46.0	46.0	50.0	37.7	55.1	28.2	44.5	44.5	48.0	36.9	52.8	27.4	42.8	42.8	45.8	36.0	50.3	26.5	40.9	40.9	43.4	34.9	47.7	25.6
	29	48.6	48.6	50.2	45.3	55.2	36.0	47.0	47.0	48.3	44.4	52.9	35.1	45.2	45.2	46.1	43.5	50.4	34.1	43.2	43.2	43.8	42.5	47.7	33.2
	32	51.2	51.2	51.3	51.3	55.3	43.4	49.6	49.6	49.6	49.6	53.0	42.6	47.7	47.7	47.7	47.7	50.5	41.6	45.6	45.6	45.7	45.7	47.9	40.7

Dry coil conditions. Total Gross Cooling Capacity (MBh) shown to the left is not applicable. In this case the Sensible Heat Capacity (SHC) is the total capacity.

All capacities shown are gross and have not considered indoor fan heat.  
 To obtain net cooling capacities subtract indoor fan heat.  
 TGC = Total Gross Cooling Capacity  
 SHC = Sensible Heat Capacity



# Performance Data System

**Table PD-14 – Gross Cooling Capacities (MBh) - Single Compressor - TTA155C Condensing Unit with TWE155B Air Handler (I-P)**

		Ambient Temperature (°F)																													
		85						95						105						115											
		Enter. Dry Bulb		Entering Wet Bulb (°F)																											
CFM	(°F)	61	67	73		61	67	73		61	67	73		61	67	73		61	67	73		61	67	73							
Airflow	(°F)	TGC	SHC	TGC	SHC	TGC	SHC	TGC	SHC	TGC	SHC	TGC	SHC	TGC	SHC	TGC	SHC	TGC	SHC	TGC	SHC	TGC	SHC	TGC	SHC	TGC	SHC	TGC	SHC	TGC	SHC
4500	75	90.4	90.4	99.1	67.0	109.4	42.8	87.8	87.8	95.6	65.6	105.2	41.5	84.6	84.6	91.5	64.0	100.7	40.0	80.9	80.9	87.0	62.2	95.7	38.3	86.2	86.2	87.6	62.5	96.1	57.7
	80	96.3	96.3	99.6	87.3	109.8	62.7	93.4	93.4	96.1	85.9	105.5	61.1	90.1	90.1	92.1	84.3	101.1	59.5	86.2	86.2	87.6	62.5	96.1	57.7	91.7	91.7	91.8	91.8	96.5	77.9
	85	102.2	102.2	102.3	102.3	109.9	82.7	99.2	99.2	99.3	99.3	106.0	81.3	95.7	95.7	95.8	95.8	101.5	79.7	91.7	91.7	91.8	91.8	96.5	77.9	97.3	97.3	97.4	97.4	97.5	97.5
5000	75	92.5	92.5	100.2	70.1	110.4	42.7	89.7	89.7	96.6	68.6	106.2	41.3	86.4	86.4	92.4	67.0	101.5	39.8	82.6	82.6	87.8	65.1	96.5	38.1	88.1	88.1	88.8	87.4	97.0	60.3
	80	98.6	98.6	100.8	92.2	110.6	65.1	95.6	95.6	97.3	90.8	106.6	63.6	92.1	92.1	93.3	89.2	102.0	62.0	88.1	88.1	88.8	87.4	97.0	60.3	93.8	93.8	93.9	93.9	97.5	82.4
	85	104.7	104.7	104.8	104.8	111.1	87.2	101.6	101.6	101.7	101.7	107.0	85.7	97.9	97.9	98.0	98.0	102.5	84.1	93.8	93.8	93.9	93.9	97.5	82.4	99.6	99.6	99.7	99.7	99.8	99.8
5500	75	94.4	94.4	101.1	72.9	111.3	43.5	91.5	91.5	97.5	71.5	107.0	42.1	88.0	88.0	93.2	69.8	102.3	40.6	84.1	84.1	88.5	68.0	97.1	38.9	89.7	89.7	89.8	89.8	97.8	62.7
	80	100.6	100.6	102.0	97.0	111.5	67.6	97.5	97.5	98.4	95.6	107.4	66.1	93.8	93.8	94.4	94.0	102.8	64.5	89.7	89.7	89.8	89.8	97.8	62.7	95.6	95.6	95.6	95.6	98.3	86.7
	85	106.9	106.9	107.0	107.0	112.0	91.5	103.6	103.6	103.7	103.7	107.9	90.1	99.8	99.8	99.9	99.9	103.3	88.5	95.6	95.6	95.6	95.6	98.3	86.7	101.5	101.5	101.6	101.6	101.7	101.7
6000	75	96.0	96.0	101.9	75.7	112.0	44.3	92.9	92.9	98.2	74.3	107.6	42.9	89.4	89.4	93.9	72.6	102.9	41.3	85.4	85.4	89.1	70.7	97.6	39.7	91.1	91.1	91.2	91.2	98.4	65.1
	80	102.3	102.3	103.0	101.7	112.4	70.7	99.1	99.1	99.1	94.1	108.2	68.4	95.3	95.3	95.4	95.4	103.5	66.8	91.1	91.1	91.2	91.2	98.4	65.1	97.1	97.1	97.2	97.2	99.1	90.9
	85	108.7	108.7	108.8	108.8	112.8	95.7	105.3	105.3	105.4	105.4	108.7	94.3	101.4	101.4	101.5	101.5	104.1	92.6	97.1	97.1	97.2	97.2	99.1	90.9	103.2	103.2	103.3	103.3	103.4	103.4
90	115.1	115.1	115.2	115.2	115.3	115.3	111.7	111.7	111.8	111.8	111.9	111.9	107.6	107.6	107.7	107.7	107.8	107.8	103.2	103.2	103.3	103.3	103.4	103.4							

Dry coil conditions. Total Gross Cooling Capacity (MBh) shown to the left is not applicable. In this case the Sensible Heat Capacity (SHC) is the total capacity.

All capacities shown are gross and have not considered indoor fan heat.  
 To obtain net cooling capacities subtract indoor fan heat.  
 TGC = Total Gross Cooling Capacity  
 SHC = Sensible Heat Capacity

**Table PD-14 – Gross Cooling Capacities (kW) - Single Compressor - TTA155C Condensing Unit with TWE155B Air Handler (SI)**

		Ambient Temperature (°C)																							
		29.4				35.0				40.6				46.1											
		Enter. Dry Bulb		Entering Wet Bulb (°C)																					
m³/h	(°C)	16.1	19.4	22.8		16.1	19.4	22.8		16.1	19.4	22.8		16.1	19.4	22.8		16.1	19.4	22.8					
Airflow	(°C)	TGC	SHC	TGC	SHC	TGC	SHC	TGC	SHC	TGC	SHC	TGC	SHC	TGC	SHC	TGC	SHC	TGC	SHC	TGC	SHC	TGC	SHC	TGC	SHC
7646	24	26.5	26.5	29.0	19.6	32.0	12.5	25.7	25.7	28.0	19.2	30.8	12.1	24.8	24.8	26.8	18.7	29.5	11.7	23.7	23.7	25.5	18.2	28.0	11.2
	27	28.2	28.2	29.2	25.6	32.1	18.4	27.4	27.4	28.1	25.2	30.9	17.9	26.4	26.4	27.0	24.7	29.6	17.4	25.2	25.2	25.7	24.2	28.2	16.9
	29	29.9	29.9	30.0	30.0	32.2	24.2	29.1	29.1	29.1	29.1	31.0	23.8	28.0	28.0	28.0	28.0	29.7	23.3	26.9	26.9	26.9	26.9	28.3	22.8
8496	24	27.1	27.1	29.3	20.5	32.3	12.5	26.3	26.3	28.3	20.1	31.1	12.1	25.3	25.3	27.1	19.6	29.7	11.6	24.2	24.2	25.7	19.1	28.2	11.2
	27	28.9	28.9	29.5	27.0	32.4	19.1	28.0	28.0	28.5	26.6	31.2	18.6	27.0	27.0	27.3	26.1	29.9	18.2	25.8	25.8	26.0	25.6	28.4	17.6
	29	30.7	30.7	30.7	30.7	32.5	25.5	29.7	29.7	29.8	29.8	31.3	25.1	28.7	28.7	28.7	28.7	30.0	24.6	27.5	27.5	27.5	27.5	28.5	24.1
9346	24	27.6	27.6	29.6	21.4	32.6	12.7	26.8	26.8	28.5	20.9	31.3	12.3	25.8	25.8	27.3	20.4	29.9	11.9	24.6	24.6	25.9	19.9	28.4	11.4
	27	29.4	29.4	29.9	28.4	32.7	19.8	28.5	28.5	28.8	28.0	31.5	19.4	27.5	27.5	27.6	27.5	30.1	18.9	26.3	26.3	26.3	26.3	28.6	18.4
	29	31.3	31.3	31.3	31.3	32.8	26.8	30.3	30.3	30.4	30.4	31.6	26.4	29.2	29.2	29.2	29.2	30.3	25.9	28.0	28.0	28.0	28.0	28.8	25.4
10195	24	28.1	28.1	29.8	22.2	32.8	13.0	27.2	27.2	28.7	21.7	31.5	12.5	26.2	26.2	27.5	21.3	30.1	12.1	25.0	25.0	26.1	20.7	28.6	11.6
	27	30.0	30.0	30.2	29.8	32.9	20.7	29.0	29.0	29.0	29.0	31.7	20.1	27.9	27.9	27.9	27.9	30.3	19.6	26.7	26.7	26.7	26.7	28.8	19.0
	29	31.8	31.8	31.9	31.9	33.0	28.0	30.8	30.8	30.9	30.9	31.8	27.6	29.7	29.7	29.7	29.7	30.5	27.1	28.4	28.4	28.5	28.5	29.0	26.6
32	33.7	33.7	33.7	33.7	33.8	33.8	32.7	32.7	32.7	32.7	32.8	32.8	31.5	31.5	31.5	31.5	31.6	31.6	30.2	30.2	30.2	30.2	30.3	30.3	

Dry coil conditions. Total Gross Cooling Capacity (MBh) shown to the left is not applicable. In this case the Sensible Heat Capacity (SHC) is the total capacity.

All capacities shown are gross and have not considered indoor fan heat.  
 To obtain net cooling capacities subtract indoor fan heat.  
 TGC = Total Gross Cooling Capacity  
 SHC = Sensible Heat Capacity



# Performance Data

# System

**Table PD-15 — Gross Cooling Capacities (MBh) TTA200B Condensing Unit with TWE200B Air Handler (I-P)**

CFM		Ambient Temperature (°F)																													
		85						95						105						115											
		Enter. Dry Bulb (°F)		Entering Wet Bulb (°F)																											
Airflow		61	67	73	81	89	61	67	73	81	89	61	67	73	81	89	61	67	73	81	89	61	67	73	81	89					
6000	75	201.0	158.5	221.1	132.8	242.4	89.9	193.1	154.4	212.5	129.3	232.6	86.5	184.9	150.2	203.5	125.7	222.1	83.0	176.4	145.8	194.2	122.0	211.7	79.5	178.4	172.6	195.1	140.3	214.1	107.4
	80	202.2	184.9	221.6	152.5	243.5	118.4	194.5	180.9	213.1	148.6	234.1	114.8	186.6	176.8	204.3	144.5	224.2	111.1	178.4	172.6	195.1	140.3	214.1	107.4	186.1	186.1	196.4	166.6	215.5	135.1
	85	206.7	206.7	222.8	178.8	244.6	146.0	200.1	200.1	214.3	174.8	235.3	142.4	193.3	193.3	205.5	170.7	225.5	138.8	186.1	186.1	196.4	166.6	215.5	135.1	196.1	196.1	198.7	193.5	216.2	160.2
	90	217.1	217.1	224.1	205.3	245.0	172.1	210.4	210.4	215.9	201.5	235.7	168.2	203.4	203.4	207.3	197.5	226.1	164.2	196.1	196.1	198.7	193.5	216.2	160.2	202.3	202.3	202.5	202.5	219.6	168.4
6675	75	204.9	165.7	225.2	130.5	246.0	91.4	196.8	161.6	216.3	126.8	235.8	87.9	188.4	157.3	207.0	123.0	225.4	84.3	179.6	152.9	197.4	119.1	214.5	80.7	182.5	182.4	198.5	146.6	217.2	111.3
	80	206.6	194.8	225.8	159.1	247.6	122.3	198.8	190.8	217.0	155.1	237.8	118.8	190.7	186.6	207.9	150.9	227.7	115.1	182.5	182.4	198.5	146.6	217.2	111.3	191.9	191.9	199.8	175.5	218.1	139.7
	85	213.4	213.4	227.0	187.8	248.8	152.5	206.6	206.6	218.2	183.8	239.1	148.9	199.4	199.4	209.1	179.7	228.3	143.9	191.9	191.9	199.8	175.5	218.1	139.7	202.3	202.3	202.5	202.5	219.6	168.4
	90	224.4	224.4	228.9	217.1	249.3	180.5	217.3	217.3	220.5	213.2	239.7	176.6	210.0	210.0	211.9	209.2	229.8	172.5	202.3	202.3	202.5	202.5	219.6	168.4	202.3	202.3	202.5	202.5	219.6	168.4
7350	75	208.3	172.6	228.5	134.9	248.9	93.0	200.0	168.4	219.3	131.2	238.5	89.5	191.3	164.0	209.8	127.3	227.8	85.8	182.3	159.5	199.1	121.9	216.7	82.0	186.3	186.3	201.3	152.7	219.8	115.0
	80	210.6	204.3	229.3	165.4	250.9	126.1	202.7	200.3	220.3	161.3	240.9	122.5	193.9	193.9	210.9	157.0	230.5	118.8	186.3	186.3	201.3	152.7	219.8	115.0	197.0	197.0	202.9	184.0	220.9	145.1
	85	219.4	219.4	230.5	196.5	251.4	157.5	212.2	212.2	221.6	192.5	241.6	153.5	204.7	204.7	212.3	188.3	231.4	149.4	202.3	202.3	202.5	202.5	219.6	168.4	202.3	202.3	202.5	202.5	219.6	168.4
	90	230.7	230.7	233.3	228.5	252.9	188.5	223.3	223.3	224.9	224.6	243.1	184.5	215.7	215.7	215.9	215.9	232.9	180.4	207.7	207.7	207.9	207.9	222.4	176.2	207.7	207.7	207.9	207.9	222.4	176.2
8025	75	211.2	179.2	231.3	139.1	251.4	94.4	202.6	174.9	221.0	134.2	240.8	90.7	193.8	170.5	211.3	129.8	229.8	86.9	184.7	166.0	201.4	125.3	218.4	83.1	190.4	190.4	203.7	158.5	221.9	118.6
	80	214.3	213.5	232.3	171.4	253.7	129.7	205.8	205.8	223.1	167.2	243.4	126.1	198.3	198.3	213.5	162.9	232.8	122.4	190.4	190.4	203.7	158.5	221.9	118.6	201.4	201.4	205.6	192.3	223.3	150.3
	85	224.6	224.6	233.7	204.9	254.5	162.9	217.2	217.2	224.6	200.8	244.4	158.8	209.4	209.4	215.2	196.6	234.0	154.6	201.4	201.4	205.6	192.3	223.3	150.3	212.4	212.4	212.6	212.6	224.8	183.8
	90	236.3	236.3	236.5	236.5	256.0	196.3	228.6	228.6	228.8	228.8	245.9	192.2	220.7	220.7	220.9	220.9	235.5	188.1	212.4	212.4	212.6	212.6	224.8	183.8	212.4	212.4	212.6	212.6	224.8	183.8

Dry coil conditions. Total Gross Cooling Capacity (MBh) shown to the left is not applicable. In this case the Sensible Heat Capacity (SHC) is the total capacity.

All capacities shown are gross and have not considered indoor fan heat.  
 To obtain net cooling capacities subtract indoor fan heat.  
 TGC = Total Gross Cooling Capacity  
 SHC = Sensible Heat Capacity

**Table PD-15 — Gross Cooling Capacities (MBh) TTA200B Condensing Unit with TWE200B Air Handler (SI)**

m³/h		Ambient Temperature (°C)																							
		29.4				35.0				40.6				46.1											
		Enter. Dry Bulb (°C)		Entering Wet Bulb (°C)																					
Airflow		16.1	19.4	22.8	26.1	16.1	19.4	22.8	26.1	16.1	19.4	22.8	26.1	16.1	19.4	22.8	26.1								
10195	24	58.8	46.4	64.7	38.9	71.0	26.3	56.5	45.2	62.2	37.9	68.1	25.3	54.1	44.0	59.6	36.8	65.0	24.3	51.6	42.7	56.9	35.7	62.0	23.3
	27	59.2	54.1	64.9	44.7	71.3	34.7	57.0	53.0	62.4	43.5	68.5	33.6	54.6	51.8	59.8	42.3	65.7	32.5	52.2	50.5	57.1	41.1	62.7	31.5
	29	60.5	60.5	65.2	52.3	71.6	42.7	58.6	58.6	62.7	51.2	68.9	41.7	56.6	56.6	60.2	50.0	66.0	40.6	54.5	54.5	57.5	48.8	63.1	39.6
	32	63.6	63.6	65.6	60.1	71.7	50.4	61.6	61.6	63.2	59.0	69.0	49.3	59.6	59.6	60.7	57.8	66.2	48.1	57.4	57.4	58.2	56.7	63.3	46.9
11340	24	60.0	48.5	65.9	38.2	72.0	26.8	57.6	47.3	63.3	37.1	69.0	25.7	55.2	46.1	60.6	36.0	66.0	24.7	52.6	44.8	57.8	34.9	62.8	23.6
	27	60.5	57.0	66.1	46.6	72.5	35.8	58.2	55.9	63.5	45.4	69.6	34.8	55.8	54.6	60.9	44.2	66.7	33.7	53.4	53.4	58.1	42.9	63.6	32.6
	29	62.5	62.5	66.5	55.0	72.8	44.6	60.5	60.5	63.9	53.8	70.0	43.6	58.4	58.4	61.2	52.6	66.8	42.1	56.2	56.2	58.5	51.4	63.9	40.9
	32	65.7	65.7	67.0	63.6	73.0	52.8	63.6	63.6	64.6	62.4	70.2	51.7	61.5	61.5	62.0	61.3	67.3	50.5	59.2	59.2	59.3	59.3	64.3	49.3
12488	24	61.0	50.5	66.9	39.5	72.9	27.2	58.5	49.3	64.2	38.4	69.8	26.2	56.0	48.0	61.4	37.3	66.7	25.1	53.4	46.7	58.3	35.7	63.4	24.0
	27	61.7	59.8	67.1	48.4	73.5	36.9	59.3	58.6	64.5	47.2	70.5	35.9	56.8	56.8	61.8	46.0	67.5	34.8	54.5	54.5	58.9	44.7	64.4	33.7
	29	64.2	64.2	67.5	57.5	73.6	46.1	62.1	62.1	64.9	56.4	70.7	44.9	59.9	59.9	62.2	55.1	67.8	43.7	57.7	57.7	59.4	53.9	64.7	42.5
	32	67.5	67.5	68.3	66.9	74.1	55.2	65.4	65.4	65.8	65.8	71.2	54.0	63.1	63.1	63.2	63.2	68.2	52.8	60.8	60.8	60.9	60.9	65.1	51.6
13633	24	61.8	52.5	67.7	40.7	73.6	27.6	59.3	51.2	64.7	39.3	70.5	26.6	56.7	49.9	61.9	38.0	67.3	25.5	54.1	48.6	59.0	36.7	63.9	24.3
	27	62.7	62.5	68.0	50.2	74.3	38.0	60.3	60.3	65.3	49.0	71.3	36.9	58.1	58.1	62.5	47.7	68.2	35.8	55.8	55.8	59.6	46.4	65.0	34.7
	29	65.8	65.8	68.4	60.0	74.5	47.7	63.6	63.6	65.8	58.8	71.6	46.5	61.3	61.3	63.0	57.6	68.5	45.3	59.0	59.0	60.2	56.3	65.4	44.0
	32	69.2	69.2	69.2	69.2	74.9	57.5	66.9	66.9	67.0	67.0	72.0	56.3	64.6	64.6	64.7	64.7	69.0	55.1	62.2	62.2	62.2	62.2	65.8	53.8

Dry coil conditions. Total Gross Cooling Capacity (MBh) shown to the left is not applicable. In this case the Sensible Heat Capacity (SHC) is the total capacity.

All capacities shown are gross and have not considered indoor fan heat.  
 To obtain net cooling capacities subtract indoor fan heat.  
 TGC = Total Gross Cooling Capacity  
 SHC = Sensible Heat Capacity



# Performance Data

## Condensing Unit

**Table PD-16 — Cooling Performance (MBh) TTA075A Condensing Unit Only (I-P)**

ODTemp °F		Suction Reference Temperature °F					
		30	35	40	45	50	55
65	Head press psig	175	181	188	195	202	210
	Cap. Btu/1000	69.1	76.2	83.6	91.2	99.0	106.9
	OD Unit kW	5.01	5.13	5.27	5.40	5.55	5.70
75	Head press psig	202	209	216	223	231	239
	Cap. Btu/1000	66.9	73.7	80.7	87.9	95.3	102.8
	OD Unit KW	5.54	5.68	5.82	5.97	6.12	6.28
85	Head press psig	232	239	247	254	262	270
	Cap. Btu/1000	64.1	70.6	77.3	84.1	91.1	98.2
	OD Unit KW	6.16	6.31	6.46	6.61	6.77	6.94
95	Head press psig	264	272	280	288	296	304
	Cap. Btu/1000	60.8	66.9	73.2	79.7	86.3	93.1
	OD Unit KW	6.86	7.02	7.17	7.33	7.49	7.66
105	Head press psig	299	307	315	323	332	341
	Cap. Btu/1000	57.0	62.7	68.7	74.8	81.1	87.6
	OD Unit KW	7.65	7.80	7.95	8.11	8.27	8.45
115	Head press psig	335	344	352	361	370	380
	Cap. Btu/1000	52.8	58.2	63.7	69.5	75.5	81.8
	OD Unit KW	8.51	8.65	8.80	8.95	9.12	9.29

Performance Data Calculated at 15 deg. subcooling and 15 deg. superheat.

**Table PD-16 — Cooling Performance (kW) TTA075A Condensing Unit Only (SI)**

ODTemp °C		Suction Reference Temperature °C					
		-1.1	1.7	4.4	7.2	10.0	12.8
18.3	Head pressure (kPA)	1208	1251	1297	1345	1395	1446
	Capacity (kW)	20.2	22.3	24.5	26.7	29.0	31.3
	OD Unit Power (kW)	5.01	5.13	5.27	5.40	5.55	5.70
23.9	Head pressure (kPA)	1396	1442	1491	1541	1593	1647
	Capacity (kW)	19.6	21.6	23.6	25.7	27.9	30.1
	OD Unit Power (kW)	5.54	5.68	5.82	5.97	6.12	6.28
29.4	Head pressure (kPA)	1600	1650	1701	1754	1808	1865
	Capacity (kW)	18.8	20.7	22.6	24.6	26.7	28.7
	OD Unit Power (kW)	6.16	6.31	6.46	6.61	6.77	6.94
35.0	Head pressure (kPA)	1822	1874	1927	1983	2040	2099
	Capacity (kW)	17.8	19.6	21.4	23.3	25.3	27.3
	OD Unit Power (kW)	6.86	7.02	7.17	7.33	7.49	7.66
40.6	Head pressure (kPA)	2059	2114	2170	2227	2287	2350
	Capacity (kW)	16.7	18.4	20.1	21.9	23.7	25.7
	OD Unit Power (kW)	7.65	7.80	7.95	8.11	8.27	8.45
46.1	Head pressure (kPA)	2313	2369	2428	2488	2551	2617
	Capacity (kW)	15.5	17.0	18.7	20.4	22.1	24.0
	OD Unit Power (kW)	8.51	8.65	8.80	8.95	9.12	9.29

Performance Data Calculated at 8.3 deg. subcooling and 8.3 deg. superheat.



# Performance Data

## Condensing Unit

**Table PD-17 — Cooling Performance (MBh) TTA085A Condensing Unit Only (I-P)**

ODTemp		Suction Reference Temperature °F					
		30	35	40	45	50	55
65	Head press PSIG	160	164	169	173	178	184
	Cap. Btuh/1000	79.8	88.0	96.6	105.7	115.1	124.9
	OD Unit KW	5.64	5.73	5.83	5.93	6.04	6.15
75	Head press PSIG	185	189	194	199	204	209
	Cap. Btuh/1000	76.4	84.1	92.3	100.8	109.8	119.2
	OD Unit KW	6.14	6.23	6.33	6.44	6.56	6.68
85	Head press PSIG	212	217	222	227	232	238
	Cap. Btuh/1000	72.6	80.0	87.7	96.0	104.6	113.6
	OD Unit KW	6.73	6.83	6.94	7.06	7.18	7.31
95	Head press PSIG	242	247	252	258	264	270
	Cap. Btuh/1000	68.6	75.7	83.1	91.0	99.3	107.9
	OD Unit KW	7.43	7.55	7.67	7.79	7.92	8.05
105	Head press PSIG	275	280	286	292	298	304
	Cap. Btuh/1000	64.4	71.2	78.4	86.0	94.0	102.3
	OD Unit KW	8.24	8.36	8.49	8.62	8.76	8.89
115	Head press PSIG	311	317	323	329	335	342
	Cap. Btuh/1000	60.0	66.6	73.6	80.9	88.6	96.5
	OD Unit KW	9.15	9.28	9.42	9.56	9.70	9.83

Performance Data Calculated at 15 deg. subcooling and 15 deg. superheat.

**Table PD-17 — Cooling Performance (kW) TTA085A Condensing Unit Only (SI)**

ODTemp		Suction Reference Temperature °C					
		-1.1	1.7	4.4	7.2	10.0	12.8
18.3	Head pressure (kPA)	1102	1132	1163	1196	1230	1266
	Capacity (kW)	23.4	25.8	28.3	30.9	33.7	36.6
	OD Unit Power (kW)	5.64	5.73	5.83	5.93	6.04	6.15
23.9	Head pressure (kPA)	1273	1304	1337	1371	1407	1444
	Capacity (kW)	22.4	24.6	27.0	29.5	32.2	34.9
	OD Unit Power (kW)	6.14	6.23	6.33	6.44	6.56	6.68
29.4	Head pressure (kPA)	1462	1494	1529	1565	1603	1642
	Capacity (kW)	21.3	23.4	25.7	28.1	30.6	33.3
	OD Unit Power (kW)	6.73	6.83	6.94	7.06	7.18	7.31
35.0	Head pressure (kPA)	1669	1704	1741	1779	1819	1860
	Capacity (kW)	20.1	22.2	24.3	26.6	29.1	31.6
	OD Unit Power (kW)	7.43	7.55	7.67	7.79	7.92	8.05
40.6	Head pressure (kPA)	1896	1934	1973	2013	2055	2099
	Capacity (kW)	18.9	20.9	23.0	25.2	27.5	29.9
	OD Unit Power (kW)	8.24	8.36	8.49	8.62	8.76	8.89
46.1	Head pressure (kPA)	2142	2184	2225	2269	2313	2358
	Capacity (kW)	17.6	19.5	21.6	23.7	25.9	28.3
	OD Unit Power (kW)	9.15	9.28	9.42	9.56	9.70	9.83

Performance Data Calculated at 8.3 deg. subcooling and 8.3 deg. superheat.



# Performance Data

## Condensing Unit

**Table PD-18 — Cooling Performance (MBh) TTA100A Condensing Unit Only (I-P)**

ODTemp		Suction Reference Temperature °F					
°F		30	35	40	45	50	55
65	Head press PSIG	174	180	186	193	199	207
	Cap. Btuh/1000	95.7	105.0	114.7	124.8	135.3	146.1
	OD Unit KW	6.69	6.84	7.01	7.19	7.37	7.58
75	Head press PSIG	200	206	212	219	226	234
	Cap. Btuh/1000	91.2	99.9	109.1	118.7	128.8	139.2
	OD Unit KW	7.38	7.54	7.72	7.91	8.12	8.34
85	Head press PSIG	228	234	241	248	256	264
	Cap. Btuh/1000	86.4	94.7	103.5	112.7	122.3	132.2
	OD Unit KW	8.19	8.37	8.57	8.77	8.99	9.22
95	Head press PSIG	259	265	273	280	288	297
	Cap. Btuh/1000	81.3	89.3	97.8	106.6	115.8	125.2
	OD Unit KW	9.13	9.33	9.54	9.76	9.99	10.23
105	Head press PSIG	292	299	307	315	324	332
	Cap. Btuh/1000	76.1	83.8	91.9	100.4	109.2	118.3
	OD Unit KW	10.19	10.41	10.64	10.88	11.12	11.36
115	Head press PSIG	328	336	344	353	362	371
	Cap. Btuh/1000	70.7	78.2	86.0	94.2	102.6	111.3
	OD Unit KW	11.37	11.61	11.86	12.11	12.36	12.60

Performance Data Calculated at 15 deg. subcooling and 15 deg. superheat.

**Table PD-18 — Cooling Performance (kW) TTA100A Condensing Unit Only (SI)**

ODTemp		Suction Reference Temperature °C					
°C		-1.1	1.7	4.4	7.2	10.0	12.8
18.3	Head pressure (kPA)	1200	1240	1283	1327	1375	1425
	Capacity (kW)	28.0	30.7	33.6	36.5	39.6	42.8
	OD Unit Power (kW)	6.69	6.84	7.01	7.19	7.37	7.58
23.9	Head pressure (kPA)	1377	1418	1462	1509	1559	1612
	Capacity (kW)	26.7	29.3	32.0	34.8	37.7	40.7
	OD Unit Power (kW)	7.38	7.54	7.72	7.91	8.12	8.34
29.4	Head pressure (kPA)	1571	1615	1662	1711	1763	1819
	Capacity (kW)	25.3	27.7	30.3	33.0	35.8	38.7
	OD Unit Power (kW)	8.19	8.37	8.57	8.77	8.99	9.22
35.0	Head pressure (kPA)	1783	1830	1880	1932	1987	2045
	Capacity (kW)	23.8	26.2	28.6	31.2	33.9	36.7
	OD Unit Power (kW)	9.13	9.33	9.54	9.76	9.99	10.23
40.6	Head pressure (kPA)	2014	2064	2117	2173	2231	2292
	Capacity (kW)	22.3	24.5	26.9	29.4	32.0	34.6
	OD Unit Power (kW)	10.19	10.41	10.64	10.88	11.12	11.36
46.1	Head pressure (kPA)	2263	2318	2375	2434	2495	2559
	Capacity (kW)	20.7	22.9	25.2	27.6	30.1	32.6
	OD Unit Power (kW)	11.37	11.61	11.86	12.11	12.36	12.60

Performance Data Calculated at 8.3 deg. subcooling and 8.3 deg. superheat.



# Performance Data

# Condensing Unit

**Table PD-19 — Cooling Performance (MBh) TTA100B Condensing Unit Only (I-P)**

ODTemp		Suction Reference Temperature °F					
		30	35	40	45	50	55
65	Head press PSIG	172	178	184	191	198	205
	Cap. Btuh/1000	93.8	103.2	113.0	123.2	133.8	144.7
	OD Unit KW	7.46	7.69	7.90	8.11	8.32	8.52
75	Head press PSIG	197	203	210	217	224	232
	Cap. Btuh/1000	88.4	97.4	106.7	116.4	126.5	136.9
	OD Unit KW	8.00	8.27	8.54	8.79	9.05	9.31
85	Head press PSIG	224	231	238	246	253	261
	Cap. Btuh/1000	82.8	91.3	100.2	109.4	118.9	128.8
	OD Unit KW	8.50	8.82	9.13	9.44	9.75	10.07
95	Head press PSIG	254	261	268	276	284	293
	Cap. Btuh/1000	77.0	85.0	93.4	102.1	111.1	120.4
	OD Unit KW	8.94	9.31	9.68	10.05	10.43	10.81
105	Head press PSIG	285	293	301	309	317	326
	Cap. Btuh/1000	71.0	78.5	86.4	94.6	103.1	111.8
	OD Unit KW	9.32	9.76	10.19	10.63	11.07	11.52
115	Head press PSIG	319	327	335	344	353	362
	Cap. Btuh/1000	64.9	72.0	79.3	87.0	94.9	103.1
	OD Unit KW	9.66	10.16	10.66	11.17	11.68	12.21

Performance Data Calculated at 15 deg. subcooling and 15 deg. superheat.

**Table PD-19 — Cooling Performance (kW) TTA100B Condensing Unit Only (SI)**

ODTemp		Suction Reference Temperature °C					
		-1.1	1.7	4.4	7.2	10.0	12.8
18.3	Head pressure (kPA)	1186	1227	1270	1315	1362	1412
	Capacity (kW)	275	30.2	33.1	36.1	39.2	42.4
	OD Unit Power (kW)	7.46	7.69	7.90	8.11	8.32	8.52
23.9	Head pressure (kPA)	1359	1403	1449	1497	1547	1600
	Capacity (kW)	25.9	28.5	31.3	34.1	37.0	40.1
	OD Unit Power (kW)	8.00	8.27	8.54	8.79	9.05	9.31
29.4	Head pressure (kPA)	1546	1593	1642	1693	1746	1802
	Capacity (kW)	24.2	26.7	29.3	32.0	34.8	37.7
	OD Unit Power (kW)	8.50	8.82	9.13	9.44	9.75	10.07
35.0	Head pressure (kPA)	1749	1799	1850	1904	1960	2019
	Capacity (kW)	22.5	24.9	27.3	29.9	32.5	35.2
	OD Unit Power (kW)	8.94	9.31	9.68	10.05	10.43	10.81
40.6	Head pressure (kPA)	1967	2019	2073	2130	2188	2249
	Capacity (kW)	20.8	23.0	25.3	27.7	30.2	32.7
	OD Unit Power (kW)	9.32	9.76	10.19	10.63	11.07	11.52
46.1	Head pressure (kPA)	2200	2255	2312	2371	2431	2494
	Capacity (kW)	19.0	21.1	23.2	25.5	27.8	30.2
	OD Unit Power (kW)	9.66	10.16	10.66	11.17	11.68	12.21

Performance Data Calculated at 8.3 deg. subcooling and 8.3 deg. superheat.



# Performance Data

# Condensing Unit

**Table PD-20 — Gross Cooling Capacities (MBh) - Both Compressors - (I-P)**  
**TTA100C Condensing Unit Only**

ODTemp °F		Suction Reference Temperature °F					
		30	35	40	45	50	55
65	Head press PSIG	147.0	152.8	158.9	165.3	172.1	179.4
	Cap. Btuh/1000	95.6	105.6	116.2	127.2	138.7	150.7
	OD Unit KW	5.6	5.8	5.9	6.1	6.3	6.4
75	Head press PSIG	169.9	175.8	182.2	188.9	196.0	203.6
	Cap. Btuh/1000	90.8	100.4	110.4	121.0	132.1	143.6
	OD Unit KW	6.2	6.3	6.5	6.7	6.8	7.0
85	Head press PSIG	195.0	201.2	207.8	214.9	222.3	230.3
	Cap. Btuh/1000	85.7	94.8	104.5	114.6	125.2	136.3
	OD Unit KW	6.8	7.0	7.2	7.3	7.5	7.7
95	Head press PSIG	222.5	229.0	236.0	243.4	251.2	259.5
	Cap. Btuh/1000	80.4	89.1	98.3	108.0	118.2	128.8
	OD Unit KW	7.6	7.8	7.9	8.1	8.3	8.5
105	Head press PSIG	252.5	259.3	266.6	274.4	282.6	291.3
	Cap. Btuh/1000	74.8	83.1	92.0	101.3	111.1	121.3
	OD Unit KW	8.5	8.6	8.8	9.0	9.2	9.4
115	Head press PSIG	284.9	292.1	299.8	307.9	316.6	325.7
	Cap. Btuh/1000	69.0	77.0	85.5	94.5	103.8	113.6
	OD Unit KW	9.4	9.6	9.8	10.0	10.2	10.4

Performance Data Calculated at 15 deg. subcooling and 15 deg. superheat.

**Table PD-20 — Gross Cooling Capacities (kW) - Both Compressors - (SI)**  
**TTA100C Condensing Unit Only**

ODTemp °C		Suction Reference Temperature °C					
		-1.1	1.7	4.4	7.2	10.0	12.8
18.3	Head pressure (kPA)	1014	1054	1095	1140	1187	1237
	Capacity (kW)	28.0	30.9	34.0	37.2	40.6	44.1
	OD Unit Power (kW)	5.59	5.76	5.93	6.09	6.27	6.45
23.9	Head pressure (kPA)	1171	1212	1256	1302	1351	1404
	Capacity (kW)	26.6	29.4	32.3	35.4	38.7	42.0
	OD Unit Power (kW)	6.17	6.33	6.50	6.67	6.85	7.04
29.4	Head pressure (kPA)	1345	1388	1433	1482	1533	1588
	Capacity (kW)	25.1	27.8	30.6	33.6	36.7	39.9
	OD Unit Power (kW)	6.85	7.00	7.17	7.35	7.53	7.74
35.0	Head pressure (kPA)	1534	1579	1627	1678	1732	1789
	Capacity (kW)	23.5	26.1	28.8	31.6	34.6	37.7
	OD Unit Power (kW)	7.62	7.78	7.95	8.13	8.32	8.53
40.6	Head pressure (kPA)	1741	1788	1838	1892	1949	2009
	Capacity (kW)	21.9	24.3	26.9	29.7	32.5	35.5
	OD Unit Power (kW)	8.49	8.65	8.82	9.01	9.22	9.43
46.1	Head pressure (kPA)	1964	2014	2067	2123	2183	2246
	Capacity (kW)	20.2	22.5	25.0	27.7	30.4	33.3
	OD Unit Power (kW)	9.44	9.61	9.79	9.99	10.20	10.43

Performance Data Calculated at 8.3 deg. subcooling and 8.3 deg. superheat.





# Performance Data

# Condensing Unit

**Table PD-21 — Gross Cooling Capacities (MBh) - Single Compressor - (I-P)**  
**TTA100C Condensing Unit Only**

ODTemp °F		Suction Reference Temperature °F					
		30	35	40	45	50	55
65	Head press PSIG	119.4	122.4	125.5	128.8	132.2	135.8
	Cap. Btuh/1000	52.0	58.0	64.3	70.8	77.6	84.7
	OD Unit KW	2.9	3.0	3.1	3.1	3.2	3.2
75	Head press PSIG	140.4	143.6	146.8	150.3	153.9	157.6
	Cap. Btuh/1000	49.6	55.3	61.3	67.6	74.1	80.9
	OD Unit KW	3.2	3.2	3.3	3.3	3.4	3.4
85	Head press PSIG	163.7	167.0	170.5	174.1	177.9	181.9
	Cap. Btuh/1000	47.1	52.4	58.1	64.1	70.4	77.0
	OD Unit KW	3.4	3.5	3.5	3.6	3.6	3.7
95	Head press PSIG	189.5	192.9	196.5	200.4	204.4	208.7
	Cap. Btuh/1000	44.3	49.4	54.8	60.5	66.6	72.9
	OD Unit KW	3.8	3.8	3.9	3.9	4.0	4.0
105	Head press PSIG	217.7	221.3	225.2	229.2	233.5	238.0
	Cap. Btuh/1000	41.4	46.2	51.4	56.8	62.6	68.7
	OD Unit KW	4.2	4.2	4.2	4.3	4.3	4.4
115	Head press PSIG	248.5	252.4	256.4	260.7	265.3	270.0
	Cap. Btuh/1000	38.3	42.9	47.8	53.0	58.5	64.3
	OD Unit KW	4.6	4.6	4.7	4.7	4.8	4.8

Performance Data Calculated at 15 deg. subcooling and 15 deg. superheat.

**Table PD-21 — Gross Cooling Capacities (kW) - Single Compressor - (SI)**  
**TTA100C Condensing Unit Only**

ODTemp °C		Suction Reference Temperature °C					
		-1.1	1.7	4.4	7.2	10.0	12.8
18.3	Head pressure (kPA)	823	844	866	888	912	936
	Capacity (kW)	15.2	17.0	18.8	20.7	22.7	24.8
	OD Unit Power (kW)	2.95	3.01	3.06	3.12	3.17	3.21
23.9	Head pressure (kPA)	968	990	1012	1036	1061	1087
	Capacity (kW)	14.5	16.2	18.0	19.8	21.7	23.7
	OD Unit Power (kW)	3.17	3.22	3.27	3.32	3.37	3.42
29.4	Head pressure (kPA)	1129	1151	1175	1200	1227	1254
	Capacity (kW)	13.8	15.3	17.0	18.8	20.6	22.5
	OD Unit Power (kW)	3.45	3.49	3.54	3.59	3.64	3.69
35.0	Head pressure (kPA)	1306	1330	1355	1381	1409	1439
	Capacity (kW)	13.0	14.5	16.0	17.7	19.5	21.3
	OD Unit Power (kW)	3.78	3.82	3.86	3.91	3.96	4.01
40.6	Head pressure (kPA)	1501	1526	1552	1580	1610	1641
	Capacity (kW)	12.1	13.5	15.0	16.6	18.3	20.1
	OD Unit Power (kW)	4.16	4.20	4.24	4.29	4.34	4.39
46.1	Head pressure (kPA)	1714	1740	1768	1798	1829	1862
	Capacity (kW)	11.2	12.6	14.0	15.5	17.1	18.8
	OD Unit Power (kW)	4.60	4.63	4.67	4.72	4.77	4.82

Performance Data Calculated at 8.3 deg. subcooling and 8.3 deg. superheat.



# Performance Data

## Condensing Unit

**Table PD-22 – Cooling Performance (MBh) TTA125B Condensing Unit Only (I-P)**

ODTemp		Suction Reference Temperature °F					
		30	35	40	45	50	55
65	Head press PSIG	169	174	180	186	193	199
	Cap. Btuh/1000	115.6	127.1	139.1	151.6	164.5	177.9
	OD Unit KW	8.89	9.17	9.43	9.70	9.96	10.23
75	Head press PSIG	194	200	206	212	219	227
	Cap. Btuh/1000	109.1	120.1	131.6	143.5	155.9	168.6
	OD Unit KW	9.43	9.77	10.10	10.43	10.76	11.10
85	Head press PSIG	221	227	234	241	248	256
	Cap. Btuh/1000	102.5	112.9	123.9	135.2	146.9	159.0
	OD Unit KW	9.98	10.37	10.77	11.17	11.58	11.99
95	Head press PSIG	250	257	264	272	280	288
	Cap. Btuh/1000	95.7	105.6	115.9	126.6	137.7	149.1
	OD Unit KW	10.52	10.98	11.45	11.92	12.41	12.90
105	Head press PSIG	282	290	297	305	313	321
	Cap. Btuh/1000	88.7	98.1	107.8	117.8	128.2	138.9
	OD Unit KW	11.06	11.59	12.14	12.69	13.25	13.83
115	Head press PSIG	317	324	332	340	349	358
	Cap. Btuh/1000	81.7	90.4	99.5	108.9	118.6	128.6
	OD Unit KW	11.59	12.21	12.83	13.47	14.11	14.78

Performance Data Calculated at 15 deg. subcooling and 15 deg. superheat.

**Table PD-22 – Cooling Performance (kW) TTA125B Condensing Unit Only (SI)**

ODTemp		Suction Reference Temperature °C					
		-1.1	1.7	4.4	7.2	10.0	12.8
18.3	Head pressure (kPA)	1163	1201	1241	1283	1327	1374
	Capacity (kW)	33.9	37.2	40.7	44.4	48.2	52.1
	OD Unit Power (kW)	8.89	9.17	9.43	9.70	9.96	10.23
23.9	Head pressure (kPA)	1335	1377	1420	1465	1512	1562
	Capacity (kW)	32.0	35.2	38.5	42.0	45.6	49.4
	OD Unit Power (kW)	9.43	9.77	10.10	10.43	10.76	11.10
29.4	Head pressure (kPA)	1523	1568	1614	1662	1712	1765
	Capacity (kW)	30.0	33.1	36.3	39.6	43.0	46.6
	OD Unit Power (kW)	9.98	10.37	10.77	11.17	11.58	11.99
35.0	Head pressure (kPA)	1727	1774	1823	1874	1928	1983
	Capacity (kW)	28.0	30.9	33.9	37.1	40.3	43.7
	OD Unit Power (kW)	10.52	10.98	11.45	11.92	12.41	12.90
40.6	Head pressure (kPA)	1947	1997	2049	2103	2159	2217
	Capacity (kW)	26.0	28.7	31.6	34.5	37.5	40.7
	OD Unit Power (kW)	11.06	11.59	12.14	12.69	13.25	13.83
46.1	Head pressure (kPA)	2185	2237	2291	2347	2405	2465
	Capacity (kW)	23.9	26.5	29.1	31.9	34.7	37.7
	OD Unit Power (kW)	11.59	12.21	12.83	13.47	14.11	14.78

Performance Data Calculated at 8.3 deg. subcooling and 8.3 deg. superheat.



# Performance Data

# Condensing Unit

**Table PD-23 — Cooling Performance (MBh) TTA155B Condensing Unit Only (I-P)**

ODTemp °F		Suction Reference Temperature °F					
		30	35	40	45	50	55
65	Head press PSIG	173	179	186	194	201	209
	Cap. Btuh/1000	140.3	154.9	170.1	185.9	202.2	218.8
	OD Unit KW	9.95	10.20	10.48	10.78	11.10	11.43
75	Head press PSIG	200	206	214	221	229	238
	Cap. Btuh/1000	136.0	150.0	164.4	179.3	194.6	210.3
	OD Unit KW	11.00	11.28	11.58	11.90	12.23	12.58
85	Head press PSIG	228	236	243	251	259	268
	Cap. Btuh/1000	130.4	143.6	157.3	171.4	185.9	200.7
	OD Unit KW	12.22	12.52	12.84	13.17	13.51	13.87
95	Head press PSIG	259	267	275	283	292	301
	Cap. Btuh/1000	123.6	136.1	149.0	162.4	176.1	190.2
	OD Unit KW	13.60	13.92	14.24	14.58	14.92	15.29
105	Head press PSIG	293	301	309	317	326	336
	Cap. Btuh/1000	115.9	127.6	139.8	152.3	165.3	178.8
	OD Unit KW	15.15	15.46	15.78	16.11	16.46	16.84
115	Head press PSIG	328	336	345	354	363	373
	Cap. Btuh/1000	107.4	118.3	129.7	141.5	153.9	166.8
	OD Unit KW	16.84	17.13	17.44	17.77	18.12	18.50

Performance Data Calculated at 15 deg. subcooling and 15 deg. superheat.

**Table PD-23 — Cooling Performance (kW) TTA155B Condensing Unit Only (SI)**

ODTemp °C		Suction Reference Temperature °C					
		-1.1	1.7	4.4	7.2	10.0	12.8
18.3	Head pressure (kPA)	1192	1238	1285	1336	1389	1444
	Capacity (kW)	41.1	45.4	49.8	54.4	59.2	64.1
	OD Unit Power (kW)	9.95	10.20	10.48	10.78	11.10	11.43
23.9	Head pressure (kPA)	1376	1424	1474	1526	1581	1638
	Capacity (kW)	39.8	43.9	48.1	52.5	57.0	61.6
	OD Unit Power (kW)	11.00	11.28	11.58	11.90	12.23	12.58
29.4	Head pressure (kPA)	1575	1625	1677	1732	1788	1848
	Capacity (kW)	38.2	42.1	46.1	50.2	54.4	58.8
	OD Unit Power (kW)	12.22	12.52	12.84	13.17	13.51	13.87
35.0	Head pressure (kPA)	1789	1841	1896	1952	2012	2073
	Capacity (kW)	36.2	39.9	43.6	47.5	51.6	55.7
	OD Unit Power (kW)	13.60	13.92	14.24	14.58	14.92	15.29
40.6	Head pressure (kPA)	2018	2073	2130	2188	2250	2315
	Capacity (kW)	33.9	37.4	40.9	44.6	48.4	52.4
	OD Unit Power (kW)	15.15	15.46	15.78	16.11	16.46	16.84
46.1	Head pressure (kPA)	2263	2320	2379	2440	2504	2571
	Capacity (kW)	31.4	34.6	38.0	41.4	45.1	48.8
	OD Unit Power (kW)	16.84	17.13	17.44	17.77	18.12	18.50

Performance Data Calculated at 8.3 deg. subcooling and 8.3 deg. superheat.



# Performance Data

# Condensing Unit

**Table PD-24 — Gross Cooling Capacities (MBh) - Both Compressors - (I-P)**  
**TTA155C Condensing Unit Only**

ODTemp		Suction Reference Temperature °F					
°F		30	35	40	45	50	55
65	Head press. PSIG	164.9	170.4	176.3	182.6	189.2	196.0
	Cap. Btuh/1000	132.3	146.2	160.9	176.2	192.1	208.5
	OD Unit KW	9.3	9.5	9.7	10.0	10.2	10.5
75	Head press. PSIG	191.3	197.3	203.6	210.3	217.2	224.4
	Cap. Btuh/1000	128.5	142.0	156.0	170.6	185.6	201.0
	OD Unit KW	10.3	10.5	10.7	11.0	11.3	11.6
85	Head press. PSIG	220.1	226.5	233.2	240.2	247.4	255.0
	Cap. Btuh/1000	123.5	136.4	149.7	163.5	177.7	192.3
	OD Unit KW	11.4	11.7	11.9	12.2	12.5	12.8
95	Head press. PSIG	251.1	257.9	265.0	272.4	280.0	287.9
	Cap. Btuh/1000	117.4	129.6	142.2	155.3	168.7	182.6
	OD Unit KW	12.7	13.0	13.3	13.6	13.9	14.2
105	Head press. PSIG	284.5	291.7	299.1	306.8	314.8	323.2
	Cap. Btuh/1000	110.4	121.9	133.8	146.1	158.8	172.0
	OD Unit KW	14.2	14.5	14.8	15.0	15.3	15.7
115	Head press. PSIG	320.2	327.7	335.4	343.4	351.8	360.6
	Cap. Btuh/1000	102.7	113.4	124.5	136.1	148.1	160.7
	OD Unit KW	15.8	16.1	16.4	16.6	16.9	17.3

Performance Data Calculated at 15 deg. subcooling and 15 deg. superheat.

**Table PD-24 — Gross Cooling Capacities (kW) - Both Compressors - (SI)**  
**TTA155C Condensing Unit Only**

ODTemp		Suction Reference Temperature °C					
°C		-1.1	1.7	4.4	7.2	10.0	12.8
18.3	Head pressure (kPA)	1137	1175	1216	1259	1304	1352
	Capacity (kW)	38.7	42.8	47.1	51.6	56.2	61.0
	OD Unit Power (kW)	9.30	9.50	9.72	9.96	10.22	10.49
23.9	Head pressure (kPA)	1319	1361	1404	1450	1497	1547
	Capacity (kW)	37.6	41.6	45.7	49.9	54.3	58.9
	OD Unit Power (kW)	10.27	10.50	10.75	11.01	11.29	11.58
29.4	Head pressure (kPA)	1517	1562	1608	1656	1706	1758
	Capacity (kW)	36.2	39.9	43.8	47.9	52.0	56.3
	OD Unit Power (kW)	11.41	11.67	11.94	12.22	12.51	12.81
35.0	Head pressure (kPA)	1731	1778	1827	1878	1930	1985
	Capacity (kW)	34.4	38.0	41.6	45.5	49.4	53.5
	OD Unit Power (kW)	12.73	13.00	13.28	13.56	13.86	14.17
40.6	Head pressure (kPA)	1962	2011	2062	2115	2170	2228
	Capacity (kW)	32.3	35.7	39.2	42.8	46.5	50.4
	OD Unit Power (kW)	14.21	14.48	14.76	15.04	15.34	15.66
46.1	Head pressure (kPA)	2208	2259	2313	2368	2426	2487
	Capacity (kW)	30.1	33.2	36.5	39.8	43.4	47.1
	OD Unit Power (kW)	15.84	16.10	16.36	16.64	16.94	17.26

Performance Data Calculated at 8.3 deg. subcooling and 8.3 deg. superheat.



# Performance Data

# Condensing Unit

**Table PD-25 – Cooling Performance (MBh) - Single Compressor - (I-P)**  
**TTA155C Condensing Unit Only**

ODTemp		Suction Reference Temperature °F					
°F		30	35	40	45	50	55
65	Head press. PSIG	137.1	139.8	142.6	145.7	149.0	152.4
	Cap. Btuh/1000	67.8	75.1	82.9	91.3	100.1	109.4
	OD Unit KW	4.8	4.8	4.8	4.9	5.0	5.0
75	Head press. PSIG	161.2	164.2	167.3	170.6	174.1	177.7
	Cap. Btuh/1000	66.9	74.1	81.7	89.7	98.1	106.9
	OD Unit KW	5.1	5.2	5.3	5.3	5.4	5.5
85	Head press. PSIG	187.7	191.0	194.3	197.9	201.6	205.4
	Cap. Btuh/1000	65.1	72.1	79.5	87.2	95.2	103.5
	OD Unit KW	5.6	5.7	5.7	5.8	5.9	6.0
95	Head press. PSIG	216.7	220.2	223.9	227.7	231.6	235.6
	Cap. Btuh/1000	62.6	69.4	76.5	83.8	91.5	99.4
	OD Unit KW	6.2	6.3	6.3	6.4	6.5	6.6
105	Head press. PSIG	248.3	252.0	255.9	260.0	264.1	268.5
	Cap. Btuh/1000	59.5	65.9	72.7	79.7	87.1	94.7
	OD Unit KW	6.9	6.9	7.0	7.1	7.1	7.2
115	Head press. PSIG	282.5	286.5	290.6	294.9	299.3	303.9
	Cap. Btuh/1000	55.8	61.9	68.3	75.0	82.0	89.3
	OD Unit KW	7.6	7.7	7.7	7.8	7.9	8.0

Performance Data Calculated at 15 deg. subcooling and 15 deg. superheat.

**Table PD-25 – Cooling Performance (kW) - Single Compressor - (SI)**  
**TTA155C Condensing Unit Only**

ODTemp		Suction Reference Temperature °C					
°C		-1.1	1.7	4.4	7.2	10.0	12.8
18.3	Head pressure (kPA)	945	964	983	1005	1027	1051
	Capacity (kW)	19.9	22.0	24.3	26.7	29.3	32.0
	OD Unit Power (kW)	4.76	4.80	4.85	4.91	4.97	5.04
23.9	Head pressure (kPA)	1112	1132	1154	1176	1200	1225
	Capacity (kW)	19.6	21.7	23.9	26.3	28.7	31.3
	OD Unit Power (kW)	5.14	5.19	5.25	5.32	5.39	5.47
29.4	Head pressure (kPA)	1294	1317	1340	1364	1390	1416
	Capacity (kW)	19.1	21.1	23.3	25.5	27.9	30.3
	OD Unit Power (kW)	5.62	5.68	5.75	5.82	5.90	5.98
35.0	Head pressure (kPA)	1494	1518	1544	1570	1597	1625
	Capacity (kW)	18.3	20.3	22.4	24.5	26.8	29.1
	OD Unit Power (kW)	6.19	6.26	6.33	6.41	6.48	6.57
40.6	Head pressure (kPA)	1712	1738	1765	1792	1821	1851
	Capacity (kW)	17.4	19.3	21.3	23.3	25.5	27.7
	OD Unit Power (kW)	6.85	6.92	6.99	7.07	7.15	7.23
46.1	Head pressure (kPA)	1948	1975	2004	2033	2064	2096
	Capacity (kW)	16.3	18.1	20.0	22.0	24.0	26.2
	OD Unit Power (kW)	7.61	7.67	7.74	7.81	7.89	7.97

Performance Data Calculated at 8.3 deg. subcooling and 8.3 deg. superheat.



# Performance Data

## Condensing Unit

**Table PD-26 — Cooling Capacities (MBh) TTA200B Condensing Unit Only (I-P)**

ODTemp		Suction Reference Temperature °F					
°F		30	35	40	45	50	55
65	Head press PSIG	181	187	194	201	208	216
	Cap. Btuh/1000	188.3	206.3	225.0	244.3	264.3	285.0
	OD Unit KW	12.97	13.31	13.66	14.04	14.45	14.88
75	Head press PSIG	207	214	221	229	237	245
	Cap. Btuh/1000	179.3	196.2	213.9	232.4	251.6	271.4
	OD Unit KW	14.39	14.76	15.15	15.57	16.02	16.48
85	Head press PSIG	236	244	251	259	267	276
	Cap. Btuh/1000	169.7	185.9	202.8	220.4	238.8	257.7
	OD Unit KW	16.07	16.47	16.90	17.36	17.83	18.32
95	Head press PSIG	268	276	284	292	301	310
	Cap. Btuh/1000	159.7	175.2	191.4	208.4	225.9	244.0
	OD Unit KW	17.98	18.43	18.90	19.39	19.89	20.40
105	Head press PSIG	302	311	319	328	338	347
	Cap. Btuh/1000	149.2	164.2	179.9	196.2	213.1	230.3
	OD Unit KW	20.13	20.63	21.14	21.67	22.19	22.70
115	Head press PSIG	339	348	358	367	377	387
	Cap. Btuh/1000	138.4	153.0	168.3	184.0	200.1	216.5
	OD Unit KW	22.50	23.06	23.62	24.18	24.72	25.23

Performance Data Calculated at 15 deg. subcooling and 15 deg. superheat.

**Table PD-26 — Cooling Capacities (MBh) TTA200B Condensing Unit Only (SI)**

ODTemp		Suction Reference Temperature °C					
°C		-1.1	1.7	4.4	7.2	10.0	12.8
18.3	Head pressure (kPA)	1248	1292	1338	1387	1437	1491
	Capacity (kW)	55.1	60.4	65.9	71.5	77.4	83.4
	OD Unit Power (kW)	12.97	13.31	13.66	14.04	14.45	14.88
23.9	Head pressure (kPA)	1430	1476	1525	1577	1631	1688
	Capacity (kW)	52.5	57.4	62.6	68.0	73.7	79.5
	OD Unit Power (kW)	14.39	14.76	15.15	15.57	16.02	16.48
29.4	Head pressure (kPA)	1630	1680	1732	1787	1844	1904
	Capacity (kW)	49.7	54.4	59.4	64.5	69.9	75.4
	OD Unit Power (kW)	16.07	16.47	16.90	17.36	17.83	18.32
35.0	Head pressure (kPA)	1848	1901	1957	2015	2076	2139
	Capacity (kW)	46.7	51.3	56.1	61.0	66.2	71.4
	OD Unit Power (kW)	17.98	18.43	18.90	19.39	19.89	20.40
40.6	Head pressure (kPA)	2085	2142	2202	2264	2329	2395
	Capacity (kW)	43.7	48.1	52.7	57.5	62.4	67.4
	OD Unit Power (kW)	20.13	20.63	21.14	21.67	22.19	22.70
46.1	Head pressure (kPA)	2340	2402	2467	2533	2602	2671
	Capacity (kW)	40.5	44.8	49.3	53.9	58.6	63.4
	OD Unit Power (kW)	22.50	23.06	23.62	24.18	24.72	25.23

Performance Data Calculated at 8.3 deg. subcooling and 8.3 deg. superheat.



# Performance Data

## Air Handler

**Table PD-27— Evaporator Fan Performance — TWE050A (I-P)**

CFM	External Static Pressure (Inches of Water Column)																						
	.10"		.20"		.30"		.40"		.50"		.60"		.70"		.80"		.90"		1.00"		1.10"		
	RPM	BHP	RPM	BHP	RPM	BHP	RPM	BHP	RPM	BHP	RPM	BHP	RPM	BHP	RPM	BHP	RPM	BHP	RPM	BHP	RPM	BHP	RPM
1400	—	—	—	—	646	0.37	698	0.42	751	0.47	803	0.52	856	0.56	908	0.61	941	0.65	973	0.68	1006	0.71	
1500	—	—	607	0.36	661	0.40	713	0.45	764	0.50	816	0.54	867	0.59	919	0.64	952	0.67	984	0.71	—	—	
1600	—	—	625	0.38	676	0.43	727	0.48	778	0.52	828	0.57	879	0.62	930	0.67	963	0.70	995	0.74	—	—	
1700	601	0.35	648	0.40	696	0.44	744	0.49	792	0.54	841	0.59	889	0.64	937	0.69	971	0.73	1005	0.77	—	—	
1800	625	0.36	671	0.41	716	0.46	762	0.51	807	0.56	853	0.61	898	0.66	944	0.71	979	0.76	—	—	—	—	
1900	642	0.40	687	0.45	731	0.50	776	0.55	820	0.60	865	0.66	909	0.71	951	0.75	987	0.80	—	—	—	—	
2000	659	0.44	703	0.49	745	0.54	790	0.60	833	0.65	877	0.70	920	0.75	957	0.80	994	0.84	—	—	—	—	
2100	674	0.48	722	0.54	770	0.60	817	0.65	857	0.70	897	0.75	936	0.80	973	0.85	1009	0.89	—	—	—	—	
	<b>0.75 HP Standard Motor and Standard Static Drive</b>										<b>1.0 HP Oversized Motor and High Static Drive</b>												

**Notes:**

1. Performance based on a wet coil and 1 inch (25.4 mm) throwaway filters.
2. Tabulated brake horsepower is the motor shaft output required.
3. Factory setting of motor sheave is 1.5 turns open. Adjustments are made in 0.5 turn increments.

**Table PD-27— Evaporator Fan Performance — TWE050A (SI)**

m <sup>3</sup> /hr	External Static Pressure (Pascal)																						
	25		50		75		100		125		150		174		199		224		249		274		
	RPM	kW	RPM	kW	RPM	kW	RPM	kW	RPM	kW	RPM	kW	RPM	kW	RPM	kW	RPM	kW	RPM	kW	RPM	kW	RPM
2379	—	—	—	—	646	0.28	698	0.31	751	0.35	803	0.39	856	0.42	908	0.45	941	0.48	973	0.51	1006	0.53	
2549	—	—	607	0.27	661	0.30	713	0.34	764	0.37	816	0.40	867	0.44	919	0.48	952	0.50	984	0.53	—	—	
2718	—	—	625	0.28	676	0.32	727	0.36	778	0.39	828	0.43	879	0.46	930	0.50	963	0.52	995	0.55	—	—	
2888	601	0.26	648	0.30	696	0.33	744	0.37	792	0.40	841	0.44	889	0.48	937	0.51	971	0.54	1005	0.57	—	—	
3058	625	0.27	671	0.31	716	0.34	762	0.38	807	0.42	853	0.45	898	0.49	944	0.53	979	0.57	—	—	—	—	
3228	642	0.30	687	0.34	731	0.37	776	0.41	820	0.45	865	0.49	909	0.53	951	0.56	987	0.60	—	—	—	—	
3398	659	0.33	703	0.37	745	0.40	790	0.45	833	0.48	877	0.52	920	0.56	957	0.60	994	0.63	—	—	—	—	
3568	674	0.36	722	0.40	770	0.45	817	0.48	857	0.52	897	0.56	936	0.60	973	0.63	1009	0.66	—	—	—	—	
	<b>0.56 kW Standard Motor and Standard Static Drive</b>										<b>0.75 kW Oversized Motor and High Static Drive</b>												

**Notes:**

1. Performance based on a wet coil and 1 inch (25.4 mm) throwaway filters.
2. Tabulated brake horsepower is the motor shaft output required.
3. Factory setting of motor sheave is 1.5 turns open. Adjustments are made in 0.5 turn increments.

**Table PD-28 — Blower Speeds — TWE050A**

Drive	Motor Drive Turns Open						
	6	5	4	3	2	1	0
Standard	N/A	590	639	688	737	786	835
High Static	N/A	713	772	832	891	951	1009



# Performance Data

# Air Handler

**Table PD-29 – Evaporator Fan Performance TWE075A (I-P)**

CFM	External Static Pressure (In. Of Water Column)																					
	0.10		0.20		0.30		0.40		0.50		0.60		0.70		0.80		0.90		1.00		1.10	
	RPM	BHP	RPM	BHP	RPM	BHP	RPM	BHP	RPM	BHP	RPM	BHP	RPM	BHP	RPM	BHP	RPM	BHP	RPM	BHP	RPM	BHP
2000	—	—	443	0.44	489	0.49	535	0.54	581	0.59	627	0.64	673	0.69	719	0.74	765	0.79	791	0.83	818	0.89
2125	—	—	453	0.46	499	0.52	546	0.57	592	0.63	638	0.68	684	0.74	730	0.79	771	0.85	798	0.90	825	0.96
2250	—	—	463	0.49	510	0.55	556	0.61	602	0.67	649	0.73	695	0.79	742	0.85	776	0.91	804	0.97	831	1.03
2375	—	—	473	0.51	520	0.57	567	0.64	613	0.70	660	0.77	706	0.83	753	0.90	782	0.97	810	1.03	838	1.10
2500	445	0.47	489	0.54	533	0.60	578	0.67	622	0.73	667	0.80	711	0.86	756	0.93	784	0.99	813	1.07	842	1.14
2625	464	0.50	506	0.57	548	0.63	589	0.69	631	0.76	672	0.82	714	0.88	757	0.95	786	1.01	815	1.09	844	1.17
2750	484	0.53	523	0.59	562	0.66	601	0.72	640	0.78	678	0.84	717	0.91	758	0.97	787	1.03	817	1.12	847	1.21
2875	504	0.56	540	0.62	576	0.68	612	0.74	648	0.81	684	0.87	720	0.93	759	0.99	789	1.05	819	1.15	850	1.24
3000	524	0.59	557	0.65	590	0.71	624	0.77	657	0.83	690	0.89	723	0.95	760	1.01	790	1.07	821	1.17	853	1.27
	<b>1.0 HP Standard Motor and Low Static Drive</b>							<b>1.0 HP Standard Motor and Drive</b>							<b>1.5 HP Oversized Motor and High Static Drive</b>							

**Notes:**

- Performance based on a wet coil and 1 inch (25.4 mm) throwaway filters.
- Tabulated brake horsepower is the motor shaft output required.
- Factory setting of motor sheave is 1.5 turns open. Adjustments are made in 0.5 turn increments.

**Table PD-29 – Continued**

CFM	External Static Pressure (In. Of Water Column)									
	1.20		1.30		1.40		1.50		1.60	
	RPM	BHP	RPM	BHP	RPM	BHP	RPM	BHP	RPM	BHP
2000	844	0.96	871	1.02	897	1.09	924	1.15	950	1.21
2125	852	1.03	879	1.09	906	1.16	933	1.22	—	—
2250	859	1.10	886	1.17	914	1.23	942	1.30	—	—
2375	866	1.17	894	1.24	922	1.30	950	1.37	—	—
2500	870	1.21	899	1.29	928	1.36	—	—	—	—
2625	874	1.25	903	1.33	932	1.42	—	—	—	—
2750	877	1.29	907	1.38	937	1.47	—	—	—	—
2875	880	1.33	911	1.43	942	1.52	—	—	—	—
3000	884	1.37	915	1.48	946	1.58	—	—	—	—
	<b>1.5 HP Oversized Motor and High Static Drive</b>									

**1.0 HP Standard Motor and Drive**

**Table PD-29 – Evaporator Fan Performance TWE075A (SI)**

m³/hr	External Static Pressure (Pascal)																					
	25		50		75		100		125		150		174		199		224		249		274	
	RPM	kW	RPM	kW	RPM	kW	RPM	kW	RPM	kW	RPM	kW	RPM	kW	RPM	kW	RPM	kW	RPM	kW	RPM	kW
3338	—	—	443	0.33	489	0.37	535	0.4	581	0.44	627	0.48	673	0.51	719	0.55	765	0.59	791	0.62	818	0.66
3547	—	—	453	0.34	499	0.39	546	0.43	592	0.47	638	0.51	684	0.55	730	0.59	771	0.63	798	0.67	825	0.72
3755	—	—	463	0.37	510	0.41	556	0.45	602	0.5	649	0.54	695	0.59	742	0.63	776	0.68	804	0.72	831	0.77
3964	—	—	473	0.38	520	0.43	567	0.48	613	0.52	660	0.57	706	0.62	753	0.67	782	0.72	810	0.77	838	0.82
4173	445	0.35	489	0.4	533	0.45	578	0.5	622	0.54	667	0.6	711	0.64	756	0.69	784	0.74	813	0.8	842	0.85
4381	464	0.37	506	0.43	548	0.47	589	0.51	631	0.57	672	0.61	714	0.66	757	0.71	786	0.75	815	0.81	844	0.87
4590	484	0.4	523	0.44	562	0.49	601	0.54	640	0.58	678	0.63	717	0.68	758	0.72	787	0.77	817	0.84	847	0.9
4798	504	0.42	540	0.46	576	0.51	612	0.55	648	0.6	684	0.65	720	0.69	759	0.74	789	0.78	819	0.86	850	0.92
5007	524	0.44	557	0.48	590	0.53	624	0.57	657	0.62	690	0.66	723	0.71	760	0.75	790	0.8	821	0.87	853	0.95
	<b>.75 kW Standard Motor and Low Static Drive</b>							<b>.75 kW Standard Motor and Drive</b>							<b>1.12 kW Oversized Motor and High Static Drive</b>							

**Notes:**

- Performance based on a wet coil and 1 inch (25.4 mm) throwaway filters.
- Tabulated brake horsepower is the motor shaft output required.
- Factory setting of motor sheave is 1.5 turns open. Adjustments are made in 0.5 turn increments.

**Table PD-29 – Continued**

m³/hr	External Static Pressure (Pascal)									
	299		324		349		374		398	
	RPM	kW	RPM	kW	RPM	kW	RPM	kW	RPM	kW
3338	844	0.72	871	0.76	897	0.81	924	0.86	950	0.9
3547	852	0.77	879	0.81	906	0.87	933	0.91	—	—
3755	859	0.82	886	0.87	914	0.92	942	0.97	—	—
3964	866	0.87	894	0.92	922	0.97	950	1.02	—	—
4173	870	0.9	899	0.96	928	1.01	—	—	—	—
4381	874	0.93	903	0.99	932	1.06	—	—	—	—
4590	877	0.96	907	1.03	937	1.1	—	—	—	—
4798	880	0.99	911	1.07	942	1.13	—	—	—	—
5007	884	1.02	915	1.1	946	1.18	—	—	—	—
	<b>1.12 kW Oversized Motor and High Static Drive</b>									

**.75 kW Standard Motor and Drive**

**Table PD-30 – Blower Speeds – TWE075A**

Drive	Motor Drive Turns Open						
	6	5	4	3	2	1	0
Standard	N/A	600	650	700	750	800	850
Low Static	N/A	428	464	499	535	571	606
High Static	N/A	700	750	800	850	900	950





# Performance Data

# Air Handler

**Table PD-31 – Evaporator Fan Performance TWE100A, TWE100B (I-P)**

CFM	External Static Pressure (In. Of Water Column)																						
	0.10		0.20		0.30		0.40		0.50		0.60		0.70		0.80		0.90		1.00		1.20		
	RPM	BHP	RPM	BHP	RPM	BHP	RPM	BHP	RPM	BHP	RPM	BHP	RPM	BHP	RPM	BHP	RPM	BHP	RPM	BHP	RPM	BHP	RPM
<b>1.5 HP Standard Motor and Low Static Drive</b>																							
2600	460	0.32	493	0.39	527	0.47	565	0.55	603	0.63	641	0.71	679	0.79	717	0.87	744	0.94	772	1.01	826	1.16	
2775	473	0.37	506	0.45	540	0.53	576	0.61	613	0.69	649	0.77	686	0.85	723	0.93	748	1.00	775	1.07	830	1.20	
2950	487	0.43	519	0.50	552	0.58	587	0.67	623	0.75	658	0.83	693	0.91	728	0.99	751	1.06	779	1.12	833	1.25	
3125	501	0.49	532	0.56	565	0.64	599	0.72	632	0.81	666	0.89	700	0.97	734	1.05	755	1.11	783	1.18	737	1.30	
3300	520	0.58	548	0.65	581	0.73	613	0.81	644	0.89	677	0.98	710	1.06	740	1.13	759	1.19	787	1.25	841	1.37	
3475	541	0.69	568	0.76	600	0.84	631	0.93	658	1.00	691	1.08	721	1.16	746	1.21	764	1.28	793	1.34	846	1.48	
3650	562	0.82	588	0.88	618	0.97	648	1.05	671	1.11	703	1.19	732	1.27	753	1.31	772	1.38	801	1.45	853	1.59	
3825	582	0.96	608	1.03	637	1.11	666	1.20	685	1.26	711	1.31	739	1.38	763	1.44	787	1.51	815	1.58	862	1.74	
4000	602	1.11	628	1.17	656	1.26	683	1.35	698	1.40	720	1.43	747	1.50	773	1.58	801	1.64	829	1.71	872	1.89	
<b>1.5 HP Standard Motor and Drive</b>																		<b>2.0 HP Oversized Motor and High Static Drive</b>					

**Notes:**

1. Performance based on a wet coil and 1 inch (25.4 mm) throwaway filters.
2. Tabulated brake horsepower is the motor shaft output required.
3. Factory setting of motor sheave is 1.5 turns open. Adjustments are made in 0.5 turn increments.
4. Low Static Drive must be field supplied.

**Table PD-31— Continued**

CFM	External Static Pressure (In. Of Water Column)			
	1.40		1.60	
	RPM	BHP	RPM	BHP
<b>2.0 HP Oversized Motor and High Static Drive</b>				
2600	881	1.30	936	1.45
2775	884	1.36	938	1.51
2960	886	1.41	939	1.57
3125	889	1.47	941	1.64
3300	892	1.54	945	1.73
3475	897	1.63	950	1.85
3650	902	1.73	955	1.99
3825	912	1.89	960	2.18
4000	922	2.04	965	2.30

**Table PD-31— Evaporator Fan Performance TWE0100A, TWE100B (SI)**

m³/hr	External Static Pressure (Pascal)																						
	25		50		75		100		125		150		174		199		224		249		299		
	RPM	kW	RPM	kW	RPM	kW	RPM	kW	RPM	kW	RPM	kW	RPM	kW	RPM	kW	RPM	kW	RPM	kW	RPM	kW	RPM
<b>1.12 kW Standard Motor and Low Static Drive</b>																							
4417	460	0.24	493	0.29	527	0.35	565	0.41	603	0.47	641	0.53	679	0.59	717	0.65	744	0.7	772	0.75	826	0.87	
4715	473	0.28	506	0.34	540	0.4	576	0.45	613	0.51	649	0.57	686	0.63	723	0.69	748	0.75	775	0.8	830	0.89	
5012	487	0.32	519	0.37	552	0.43	587	0.5	623	0.56	658	0.62	693	0.68	728	0.74	751	0.79	779	0.84	833	0.93	
5309	501	0.37	532	0.42	565	0.48	599	0.54	632	0.6	666	0.66	700	0.72	734	0.78	755	0.83	783	0.88	737	0.97	
5607	520	0.43	548	0.48	581	0.54	613	0.6	644	0.66	677	0.73	710	0.79	740	0.84	759	0.89	787	0.93	841	1.02	
5904	541	0.51	568	0.57	600	0.63	631	0.69	658	0.75	691	0.8	721	0.87	746	0.9	764	0.95	793	1	846	1.1	
6201	562	0.61	588	0.66	618	0.72	648	0.78	671	0.83	703	0.89	732	0.95	753	0.98	772	1.03	801	1.08	853	1.19	
6499	582	0.72	608	0.77	637	0.83	666	0.89	685	0.94	711	0.98	739	1.03	763	1.07	787	1.13	815	1.18	862	1.3	
6796	602	0.83	628	0.87	656	0.94	683	1.01	698	1.04	720	1.07	747	1.12	773	1.18	801	1.22	829	1.28	872	1.41	
<b>1.12 kW Standard Motor and Drive</b>																		<b>1.49 kW Oversized Motor and High Static Drive</b>					

**Notes:**

1. Performance based on a wet coil and 1 inch (25.4 mm) throwaway filters.
2. Tabulated brake horsepower is the motor shaft output required.
3. Factory setting of motor sheave is 3.0 turns open. Adjustments are made in 0.5 turn increments.
4. Low Static Drive must be field supplied.

**Table PD-31— Continued**

m³/hr	External Static Pressure (Pascal)			
	349		398	
	RPM	kW	RPM	kW
<b>1.49 kW Oversized Motor and High Static Drive</b>				
4417	881	0.97	936	1.08
4715	884	1.01	938	1.13
5012	886	1.05	939	1.17
5309	889	1.1	941	1.22
5607	892	1.15	945	1.29
5904	897	1.22	950	1.38
6201	902	1.29	955	1.48
6499	912	1.41	960	1.63
6796	922	1.52	965	1.72

**Table PD-32 – Blower Speeds – TWE100A, TWE100B**

Drive	Motor Sheave Turns Open						
	6	5	4	3	2	1	0
Standard	N/A	587	629	671	713	755	796
Low Static	N/A	453	485	518	550	583	615
High Static	N/A	606	641	677	713	748	784
High Static II	N/A	745	789	833	877	920	965



# Performance Data

# Air Handler

**Table PD-33 – Evaporator Fan Performance – TWE155B (I-P)**

CFM	External Static Pressure (Inches of Water Column)																									
	.10"		.20"		.30"		.40"		.50"		.60"		.70"		.80"		.90"		1.00"		1.20"		1.40"			
	RPM	BHP	RPM	BHP	RPM	BHP	RPM	BHP	RPM	BHP	RPM	BHP	RPM	BHP	RPM	BHP	RPM	BHP	RPM	BHP	RPM	BHP	RPM	BHP	RPM	BHP
	<b>2.0 HP Standard Motor and Drive</b>												<b>3.0 HP Oversized Motor and High Static Drive</b>													
4000	628	1.34	653	1.38	678	1.43	692	1.48	708	1.52	723	1.57	738	1.60	749	1.61	759	1.62	795	1.66	851	1.85	907	2.03		
4250	633	1.37	658	1.41	683	1.46	697	1.51	713	1.55	728	1.60	743	1.62	751	1.63	770	1.64	806	1.71	862	1.90	918	2.11		
4500	637	1.40	662	1.44	687	1.49	701	1.53	717	1.58	732	1.63	747	1.64	754	1.65	782	1.67	817	1.76	873	1.96	929	2.19		
4750	641	1.42	666	1.50	691	1.53	705	1.61	721	1.63	736	1.65	751	1.66	765	1.67	793	1.72	828	1.81	884	2.01	940	2.27		
5000	645	1.44	670	1.52	695	1.56	710	1.65	725	1.67	739	1.68	758	1.70	777	1.74	806	1.81	839	1.91	896	2.13	—	—		
5260	650	1.46	675	1.53	700	1.59	716	1.67	728	1.70	741	1.73	765	1.75	790	1.82	819	1.92	849	2.03	907	2.28	—	—		
5500	652	1.47	678	1.55	703	1.63	721	1.71	734	1.75	747	1.78	775	1.83	804	1.92	832	2.03	861	2.15	920	2.44	—	—		
5750	653	1.48	680	1.57	706	1.68	726	1.76	743	1.81	761	1.86	789	1.94	817	2.04	846	2.16	875	2.29	935	2.61	—	—		
6000	655	1.49	681	1.59	709	1.74	731	1.80	752	1.87	774	1.94	803	2.05	831	2.17	860	2.29	889	2.44	950	2.78	—	—		

**Notes:**

1. Performance based on a wet coil and 2 inch (51 mm) throwaway filters.
2. Tabulated brake horsepower is the motor shaft output required.
3. Factory setting of motor sheave is 1.5 turns open. Adjustments are made in 0.5 turn increments.

**Table PD-33 – Evaporator Fan Performance TWE155B (SI)**

m <sup>3</sup> /hr	External Static Pressure (Pascal)																									
	25		50		75		100		125		150		174		199		224		249		299		349			
	RPM	kW	RPM	kW	RPM	kW	RPM	kW	RPM	kW	RPM	kW	RPM	kW	RPM	kW	RPM	kW	RPM	kW	RPM	kW	RPM	kW	RPM	kW
	<b>1.49 kW Standard Motor and Drive</b>												<b>2.24 kW Oversized Motor and High Static Drive</b>													
6796	628	1	653	1.03	678	1.07	692	1.1	708	1.13	723	1.17	738	1.19	749	1.2	759	1.21	795	1.24	851	1.38	907	1.51		
7221	633	1.02	658	1.05	683	1.09	697	1.13	713	1.16	728	1.19	743	1.21	751	1.22	770	1.22	806	1.28	862	1.42	918	1.57		
7646	637	1.04	662	1.07	687	1.11	701	1.14	717	1.18	732	1.22	747	1.23	754	1.23	782	1.25	817	1.31	873	1.46	929	1.63		
8070	641	1.06	666	1.12	691	1.14	705	1.2	721	1.22	736	1.23	751	1.24	765	1.25	793	1.28	828	1.35	884	1.5	940	1.69		
8495	645	1.07	670	1.13	695	1.16	710	1.23	725	1.25	739	1.25	758	1.27	777	1.3	806	1.35	839	1.42	896	1.59	—	—		
8937	650	1.09	675	1.14	700	1.19	716	1.25	728	1.27	741	1.29	765	1.3	790	1.36	819	1.43	849	1.51	907	1.7	—	—		
9345	652	1.1	678	1.16	703	1.22	721	1.28	734	1.3	747	1.33	775	1.36	804	1.43	832	1.51	861	1.6	920	1.82	—	—		
9769	653	1.1	680	1.17	706	1.25	726	1.31	743	1.3	761	1.39	789	1.45	817	1.52	846	1.61	875	1.71	935	1.95	—	—		
10194	655	1.11	681	1.19	709	1.3	731	1.34	752	1.35	774	1.45	803	1.53	831	1.62	860	1.71	889	1.82	950	2.07	—	—		

**Notes:**

1. Performance based on a wet coil and 2 inch (51 mm) throwaway filters.
2. Tabulated brake horsepower is the motor shaft output required.
3. Factory setting of motor sheave is 1.5 turns open. Adjustments are made in 0.5 turn increments.

**Table PD-34 – Blower Speeds – TWE155B**

Drive	Motor Sheave Turns Open						
	6	5	4	3	2	1	0
Standard	619	648	677	705	734	763	N/A
High Static	777	806	835	863	892	921	950

# Performance Data

## Air Handler

**Table PD-35 — Evaporator Fan Performance TWE200B (I-P)**

External Static Pressure (In. Of Water Column)																								
CFM	0.10		0.20		0.30		0.40		0.50		0.60		0.70		0.80		0.90		1.00		1.20		140	
	RPM	BHP	RPM	BHP	RPM	BHP	RPM	BHP	RPM	BHP	RPM	BHP	RPM	BHP	RPM	BHP	RPM	BHP	RPM	BHP	RPM	BHP	RPM	BHP
5200	—	—	461	0.74	503	0.91	545	1.07	587	1.03	619	1.17	685	1.40	723	1.59	750	1.74	777	1.89	851	2.19	898	2.39
5525	—	—	479	0.88	521	1.04	563	1.21	605	1.21	640	1.35	701	1.58	739	1.77	766	1.92	793	2.07	859	2.37	906	2.60
5850	—	—	497	1.01	539	1.18	581	1.34	623	1.39	661	1.53	717	1.76	755	1.95	782	2.10	809	2.25	868	2.55	915	2.81
6175	473	0.99	515	1.15	557	1.31	599	1.48	641	1.57	682	1.71	732	1.94	769	2.12	796	2.27	823	2.43	877	2.73	924	3.02
6500	492	1.12	534	1.28	576	1.45	618	1.61	660	1.75	702	1.90	748	2.12	784	2.30	811	2.45	838	2.60	886	2.91	933	3.22
6825	510	1.25	552	1.42	594	1.59	636	1.75	678	1.91	723	2.10	763	2.30	794	2.47	820	2.62	846	2.77	894	3.09	941	3.42
7150	528	1.38	570	1.56	612	1.73	654	1.90	697	2.07	744	2.30	779	2.49	804	2.64	830	2.78	855	2.94	903	3.26	950	3.62
7475	550	1.61	594	1.77	640	1.92	683	2.08	721	2.29	760	2.50	790	2.67	815	2.81	840	2.96	865	3.11	914	3.47	959	3.85
7800	572	1.83	618	1.97	668	2.10	712	2.27	746	2.52	776	2.69	802	2.84	826	2.99	851	3.13	876	3.27	926	3.67	969	4.08
<b>3.0 HP Standard Motor and Low Static Drive</b>			<b>3.0 HP Standard Motor and Low Static Drive System II</b>						<b>3.0 HP Standard Motor and Standard Drive System</b>						<b>5.0 HP Oversized Motor and High Static Drive System</b>									

**Notes:**

- Performance based on a wet coil and 2 inch (51mm) throwaway filters.
- Tabulated brake horsepower is the motor shaft output required.
- Factory setting of motor sheave is 1.5 turns open. Adjustments are made in 0.5 turn increments.
- Low static drive components referencing this note are field supplied.

**Table PD-35 — Continued**

External Static Pressure (In. Of Water Column)				
CFM	1.60		1.80	
	RPM	BHP	RPM	BHP
<b>5.0 HP Oversized Motor and High Static Drive System</b>				
5200	944	2.75	989	3.12
5525	952	2.96	997	3.33
5850	961	3.17	1006	3.54
5175	970	3.38	1015	3.75
8500	978	3.59	1023	3.96
8825	986	3.80	—	—
7150	994	4.01	—	—
7475	1003	4.25	—	—
7800	1012	4.50	—	—

**Table PD-35 — Evaporator Fan Performance TWE200B (SI)**

External Static Pressure (Pascal)																								
m³/hr	25		50		75		100		125		150		174		199		224		249		299		349	
	RPM	kW	RPM	kW	RPM	kW	RPM	kW	RPM	kW	RPM	kW	RPM	kW	RPM	kW	RPM	kW	RPM	kW	RPM	kW	RPM	kW
8835	—	—	461	0.55	503	0.68	545	0.8	587	0.77	619	0.87	685	1.04	723	1.19	750	1.3	777	1.41	851	1.63	898	1.78
9387	—	—	479	0.66	521	0.78	563	0.9	605	0.9	640	1.01	701	1.18	739	1.32	766	1.43	793	1.54	859	1.77	906	1.94
9939	—	—	497	0.75	539	0.88	581	1	623	1.04	661	1.14	717	1.31	755	1.45	782	1.57	809	1.68	868	1.9	915	2.1
10491	473	0.74	515	0.86	557	0.98	599	1.1	641	1.17	682	1.28	732	1.45	769	1.58	796	1.69	823	1.81	877	2.04	924	2.52
11044	492	0.84	534	0.95	576	1.08	618	1.2	660	1.3	702	1.42	748	1.58	784	1.72	811	1.83	838	1.94	886	2.17	933	2.4
11596	510	0.93	552	1.06	594	1.19	636	1.3	678	1.42	723	1.57	763	1.72	794	1.84	820	1.95	846	2.07	894	2.3	941	2.55
12148	528	1.03	570	1.16	612	1.29	654	1.42	697	1.54	744	1.72	779	1.86	804	1.97	830	2.07	855	2.19	903	2.43	950	2.7
12700	550	1.2	594	1.32	640	1.43	683	1.55	721	1.71	760	1.87	790	1.99	815	2.1	840	2.21	865	2.32	914	2.59	959	2.87
13252	572	1.36	618	1.47	668	1.57	712	1.69	746	1.88	776	2.01	802	2.12	826	2.23	851	2.33	876	2.44	926	2.74	969	3.04
<b>2.24 kW Standard Motor and Low Static Drive System</b>			<b>2.24 kW Standard Motor and Low Static Drive System II</b>						<b>2.24 kW Standard Motor and Standard Drive System</b>						<b>3.73 kW Oversized Motor and High Static Drive System</b>									

**Notes:**

- Performance based on a wet coil and 2 inch (51mm) throwaway filters.
- Tabulated brake horsepower is the motor shaft output required.
- Factory setting of motor sheave is 1.5 turns open. Adjustments are made in 0.5 turn increments.
- Low static drive components referencing this note are field supplied.

**Table PD-35 — Continued**

External Static Pressure (Pascal)				
m³/hr	398		448	
	RPM	kW	RPM	kW
<b>3.73 kW Oversized Motor and High Static Drive System</b>				
8835	944	2.05	989	2.33
9387	952	2.21	997	2.48
9939	961	2.36	1006	2.64
10491	970	2.52	1015	2.8
11044	978	2.68	1023	2.95
11596	986	2.83	—	—
12148	994	2.99	—	—
12700	1003	3.17	—	—
13252	1012	3.36	—	—

**Table PD-36— Blower Speeds — TWE200B**

Drive	Motor Sheave Turns Open						
	6	5	4	3	2	1	0
Standard	706	732	758	784	811	837	863
Low Static I	457	478	500	521	542	563	585
Low Static II	574	595	617	638	659	680	702
High Static	N/A	821	862	903	945	986	1027



# Performance Data

**Table PD-37— Discharge Plenum And Grille Assembly Throw Distance (ft) — Air Handler**

Unit Model No.	CFM	m <sup>3</sup> /h	Louver Angle Deflection Position			
			Straight	20, ft (m)	40, ft (m)	55, ft (m)
TWE050	1400	2380	38 (11.6)	24 (7.3)	22 (6.7)	18 (5.5)
	1600	2718	42 (12.8)	31 (9.4)	26 (7.9)	20 (6.1)
	1800	3060	46 (14.0)	37 (11.3)	29 (8.8)	22 (6.7)
	2000	3398	48 (14.6)	43 (13.1)	33 (10.1)	24 (7.3)
	2200	3737	51 (15.5)	50 (15.2)	36 (11.0)	25 (7.6)
TWE075	2100	3568	49 (14.9)	38 (11.6)	31 (9.4)	27 (8.2)
	2400	4079	52 (15.9)	43 (13.1)	35 (10.7)	29 (8.8)
	2700	4586	55 (16.8)	48 (14.6)	38 (11.6)	31 (9.4)
	3000	5098	58 (17.7)	53 (16.2)	42 (12.8)	32 (9.8)
TWE100	3200	5436	56 (17.1)	46 (14.0)	38 (11.6)	30 (9.1)
	3600	6116	62 (18.9)	51 (15.5)	42 (12.8)	33 (10.1)
	4000	6797	66 (20.1)	57 (17.4)	47 (14.3)	35 (10.7)
	4400	7477	71 (21.6)	62 (18.9)	52 (15.9)	38 (11.6)
	4800	8154	76 (23.2)	67 (20.4)	56 (17.1)	42 (12.8)
TWE155	4300	7304	42 (12.8)	32 (9.8)	29 (8.8)	21 (6.4)
	4900	8327	47 (14.3)	38 (11.6)	32 (9.8)	25 (7.6)
	5400	9176	52 (15.9)	44 (13.4)	37 (11.3)	29 (8.8)
	6000	10195	57 (17.4)	49 (14.9)	41 (12.5)	32 (9.8)
TWE200	5600	9515	50 (15.2)	40 (12.2)	33 (10.1)	27 (8.2)
	6400	10872	56 (17.1)	46 (14.0)	38 (11.6)	30 (9.1)
	7200	12233	62 (18.9)	51 (15.5)	42 (12.8)	33 (10.1)
	8000	13594	66 (20.1)	57 (17.4)	47 (14.3)	35 (10.7)

Throw distance values are based on a terminal velocity of 75 FPM (0.38 m/s).

Throw distance values at other terminal velocities may be established by multiplying throw distances in table above by throw factor:

Terminal Velocity		Throw Factor
50 fpm (.25 m/s)	x	1.50
100 fpm (.51 m/s)	x	.75
150 fpm (.76 m/s)	x	.50

**Table PD-38— Static Pressure Drop Through Accessories (Inches Of Water Column)<sup>1</sup> — Air Handler**

Unit Model No.	CFM	m <sup>3</sup> /h	Return Grille		Discharge Plenum and Grille <sup>2</sup>		Electric Heaters (kW)			
			In. wc <sup>1</sup>	Pascal	In. wc <sup>1</sup>	Pascal	5-10	15-20	25-30	35-50
TWE050A	1400	2380	.09	(22.4)	.16	(39.8)	.06	.06	.12	—
	1600	2718	.12	(29.9)	.21	(52.3)	.08	.08	.14	—
	2000	3398	.18	(44.8)	.33	(82.2)	.13	.13	.19	—
TWE075A	2100	3568	.05	(12.5)	.19	(47.3)	.02	.03	.05	.08
	2400	4079	.08	(19.9)	.27	(67.2)	.03	.06	.08	.12
	3000	5098	.13	(32.4)	.40	(99.6)	.06	.12	.17	.23
TWE100A	2800	4756	.04	(10.0)	.34	(84.7)	.03	.04	.14	.20
TWE100B	3200	5436	.07	(17.4)	.43	(107.1)	.06	.13	.19	.26
TWE155B	4300	7304	.07	(17.4)	.18	(44.8)	.02	.02	.04	.05
	4800	8154	.09	(22.4)	.23	(57.3)	.03	.03	.06	.08
	6000	10195	.15	(37.4)	.34	(84.7)	.06	.06	.12	.17
TWE200B	5600	9515	.07	(17.4)	.32	(79.7)	.04	.04	.10	.15
	6400	10872	.11	(27.4)	.43	(107.1)	.06	.06	.13	.19
	8000	13594	.17	(42.3)	.66	(164.3)	.10	.10	.20	.30

1. Return air filter ESP included in Fan Performance Table data.

2. At louver opening angle of 42°F (5.5°C). For ESP at other angle openings, see accessory Installer's Guide.



# Performance Data

**Table PD-39 – Auxiliary Electric Heat Capacity – Air Handler**

Unit Model No.	Total kW	No. of Stages	Stage 1		Stage 2		Total	
			kW Input	Btu Output	kW Input	Btu Output	kW Input	Btu Output
	5.00	1	5.00	17,065	—	—	5.00	17,065
TWE050/075/100AD	9.96	1	9.96	33,993	—	—	9.96	33,993
TWE100BD	14.96	1	14.96	51,058	—	—	14.96	51,058
	24.92	2	14.96	51,058	9.96	33,993	24.92	85,051
TWE075, 100AD								
TWE100BD	34.88	2	19.92	67,987	14.96	51,058	34.88	119,045
	10.00	1	10.00	34,130	—	—	10.00	34,130
TWE155,200B	19.92	1	19.92	67,987	—	—	19.92	67,987
	29.92	2	19.92	67,987	10.00	34,130	29.92	102,117
	49.84	2	29.92	102,117	19.92	67,987	49.84	170,104

\*Heaters are rated at 400v. For other than rated voltage,

$$\text{Capacity} = \left( \frac{\text{Voltage}}{\text{Rated Voltage}} \right)^2 \times \text{Rated Capacity and kW} = \left( \frac{\text{Voltage}}{\text{Rated Voltage}} \right)^2 \text{ Rated kW.}$$



# Electrical Data

**Table ED-1 – Unit Wiring – Condensing Units**

Unit Model No.	Unit Operating Voltage	Minimum Circuit Ampacity	Maximum Fuse Size or Maximum Circuit Breaker
TTA075A	380/415	15.5	25
TTA085A	380/415	17.8	25
TTA100A	380/415	21.5	35
TTA100B	380/415	26.3	35
TTA125B	380/415	27.4	35
TTA155B	380/415	28.3	35
TTA155C	380/415	35.1	45
TTA200B	380/415	39.3	50

**Table ED-2 – Electrical Characteristics – Motors – Condensing Units**

Compressor Motor					Condenser Fan Motor				
Unit		Amps			Unit		Amps		
Model No.	No.	Phase	RLA (Ea.)	LRA (Ea.)	No.	Phase	FLA (Ea.)	LRA (Ea.)	
TTA075A	1	3	11.0	90.0	1	1	1.6	4.0	
TTA085A	1	3	11.9	118.0	1	1	2.7	9.3	
TTA100A	1	3	14.9	118.0	1	1	2.7	9.3	
TTA100B	2	3	10.5	71.0	1	1	2.7	7.0	
TTA125B	2	3	11.0	64.0	2	1	2.7	7.0	
TTA155B	2	3	11.0	90.0	2	1	1.6	4.0	
TTA155C	1	3	14.0	92.5	2	1	1.6	3.8	
TTA200B	2	3	14.9	118.0	2	1	2.7	9.3	

NOTE:

1. Electrical characteristics reflect nameplate values and are calculated in accordance with UL and ARI specifications.

**Table ED-3 – Electrical Characteristics – Motors – Air Handler**

Unit			Standard Fan Motor			Oversized Fan Motor		
Model No.	Volts	Phase	Amps		Phase	Amps		
			FLA	LRA		FLA	LRA	
TWE050	380/415	3	2.9	8.2	3	1.8	21.6	
TWE075	380/415	3	3.8	19.7	3	4.0	27.5	
TWE100	380/415	3	4.0	27.5	3	5.3	37.5	
TWE155	380/415	3	4.5	36.2	3	6.9	39.2	
TWE200	380/415	3	7.6	45.0	3	9.0	65.1	

**Table ED-4 – Unit Wiring – Air Handler**

Unit Model No.	Minimum Unit Operating Voltage Range	Maximum Fuse Circuit Ampacity	Size or Maximum Circuit Breaker
TWE050	380/415	4	15
TWE075	380/415	5	15
TWE100	380/415	5	15
TWE155	380/415	6	15
TWE200	380/415	10	15

# Electric Heat Data

**Table ED-5 — Unit Wiring With Electric Heat (Single Point Connection) — Air Handlers**

Heater Model No.	Heater kW Rating <sup>1</sup>	To Use with Unit	Control Stages	Minimum Circuit Ampacity <sup>2</sup>	Maximum Fuse Breaker Size <sup>2</sup>
BAYHTRL405A	5.00	TWE050AD	1	11	15
BAYHTRL410A	9.96		1	17	20
BAYHTRL415A	14.96		1	24	25
BAYHTRL425A	24.92		2	37	40
BAYHTRL405A	5.00	TWE075AD	1	12	15
BAYHTRL410A	9.96		1	18	20
BAYHTRL415A	14.96		1	25	25
BAYHTRL425A	24.92		2	38	40
BAYHTRL435A	34.88		2	51	60
BAYHTRL405A	5.00	TWE100AD, TWE100BD	1	12	15
BAYHTRL410A	9.96		1	19	20
BAYHTRL415A	14.96		1	25	25
BAYHTRL425A	29.92		2	38	40
BAYHTRL435A	34.88		2	52	60
BAYHTRM410A	10.00	TWE155BD	1	19	20
BAYHTRM420A	19.92		1	32	35
BAYHTRM430A	29.92		2	46	50
BAYHTRM450A	49.84		2	72	80
BAYHTRM410A	10.00	TWE200BD	1	23	25
BAYHTRM420A	19.92		1	36	40
BAYHTRM430A	29.92		2	49	50
BAYHTRM450A	49.84		2	76	80

1. kW ratings are at 400v for 3 phase, 400v air handlers

For other than rated voltage, ampacity =  $\left(\frac{\text{Voltage}}{\text{Rated Voltage}}\right)^2 \times \text{Rated Capacity}$  and kW =  $\left(\frac{\text{Voltage}}{\text{Rated Voltage}}\right)^2 \times \text{Rated kW}$ .

2. Any power supply and circuits must be wired and protected in accordance with local codes. MCA and Maximum Fuse Size is based on 400V.

3. Field wire must be rated at least 167°F (75°C).

4. Field wire must be rated at least 194°F (90°C).

# Jobsite Connections

Wiring shown with dashed lines is to be furnished and installed by the customer. All customer-supplied wiring must be copper only and must conform to local electrical codes.

**NOTE:**

1. When electric heater accessory is used, single point power entry or dual point power entry is field optional. Single point power entry option is through electric heater only.

**TTA050/TWE050A**

**Field Wiring:**

- A — 3 power wires. Line voltage for 3 phase, 2 wires for single phase.
- B — 3 power wires. Line voltage for 3 phase, 2 wires for single phase.
- C — Cooling only thermostat: 3 wires, 24 volts.
  - One-stage electric heat: add 1 additional wire, 24 volts.
  - Two-stage electric heat: add 2 additional wires, 24 volts.
- D — 2 wires, 24 volts.

**(2) TTA050/TWE100B**

**Field Wiring:**

- A — 3 power wires. Line voltage for 3 phase, 2 wires for single phase.
- B — 3 power wires. Line voltage for 3 phase, 2 wires for single phase.
- C — Cooling only thermostat: 4 wires, 24 volts.
  - One-stage electric heat add 1 additional wire, 24 volts.
  - Two-stage electric heat: add 2 additional wires, 24 volts.
- D — 2 wires, 24 volts to outdoor section "A"
  - 2 wires, 24 volts to outdoor section "B"

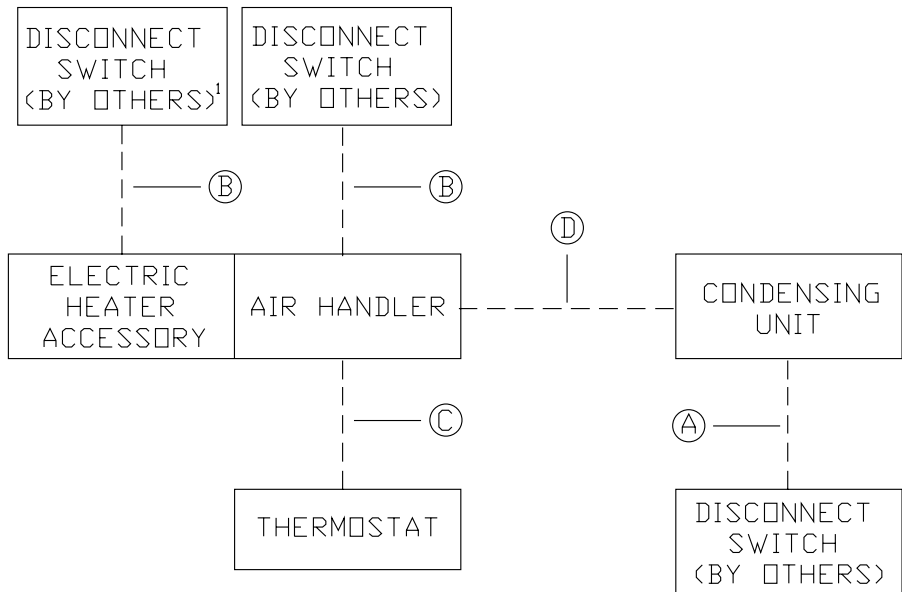

**TTA075A/TWE075A;**

**TTA085/TWE075A;**

**TTA085/TWE100A;**

**TTA100A/TWE100A**

**Field Wiring:**

- A — 3 power wires, line voltage.
- B — 3 power wires, line voltage for 3 phase; 2 wires for single phase.
- C — Cooling only thermostat: 3 wires, 24 volts.
  - One-stage electric heat: add 1 additional wire, 24 volts.
  - Two-stage electric heat: add 2 additional wires; 24 volts.
- D — 4 wires, 24 volts.

**TTA100B/TWE100B**

**Field Wiring:**

- A — 3 power wires, line voltage.
- B — 3 power wires, line voltage for 3 phase; 2 wires for single phase.
- C — Cooling only thermostat: 4 wires, 24 volts.
  - One-stage electric heat: add 1 additional wire, 24 volts.
  - Two-stage electric heat: add 2 additional wires, 24 volts.

- D — 5 wires, 24 volts.

**TTA125B/TWE155B;**

**TTA155B/TWE155B;**

**TTA200B/TWE200B;**

**TTA155C/TWE155B**

**Field Wiring**

- A — 3 power wires, line voltage
- B — 3 power wires, line voltage
- C — Cooling only thermostat: 4 wires, 24 volts.
  - One-stage electric heat: add 1 additional wire, 24 volts.
  - Two-stage electric heat: add 2 additional wires, 24 volts.
- D — 5 wires, 24 volts.

**(2) TTA075A/TWE155B;**

**(2) TTA100A/TWE200B**

**Field Wiring:**

- A — 3 power wires, line voltage.
- B — 3 power wires, line voltage.
- C — Cooling only thermostat: 4 wires, 24 volts.
  - One-stage electric heat: add 1 additional wire, 24 volts.
  - Two-stage electric heat: add 2 additional wires, 24 volts.
- D — 6 wires, 24 volts.



# Typical Wiring

# Air Handler

## Air Handler

Typical wiring diagram. For specific wiring, see individual Service Facts.

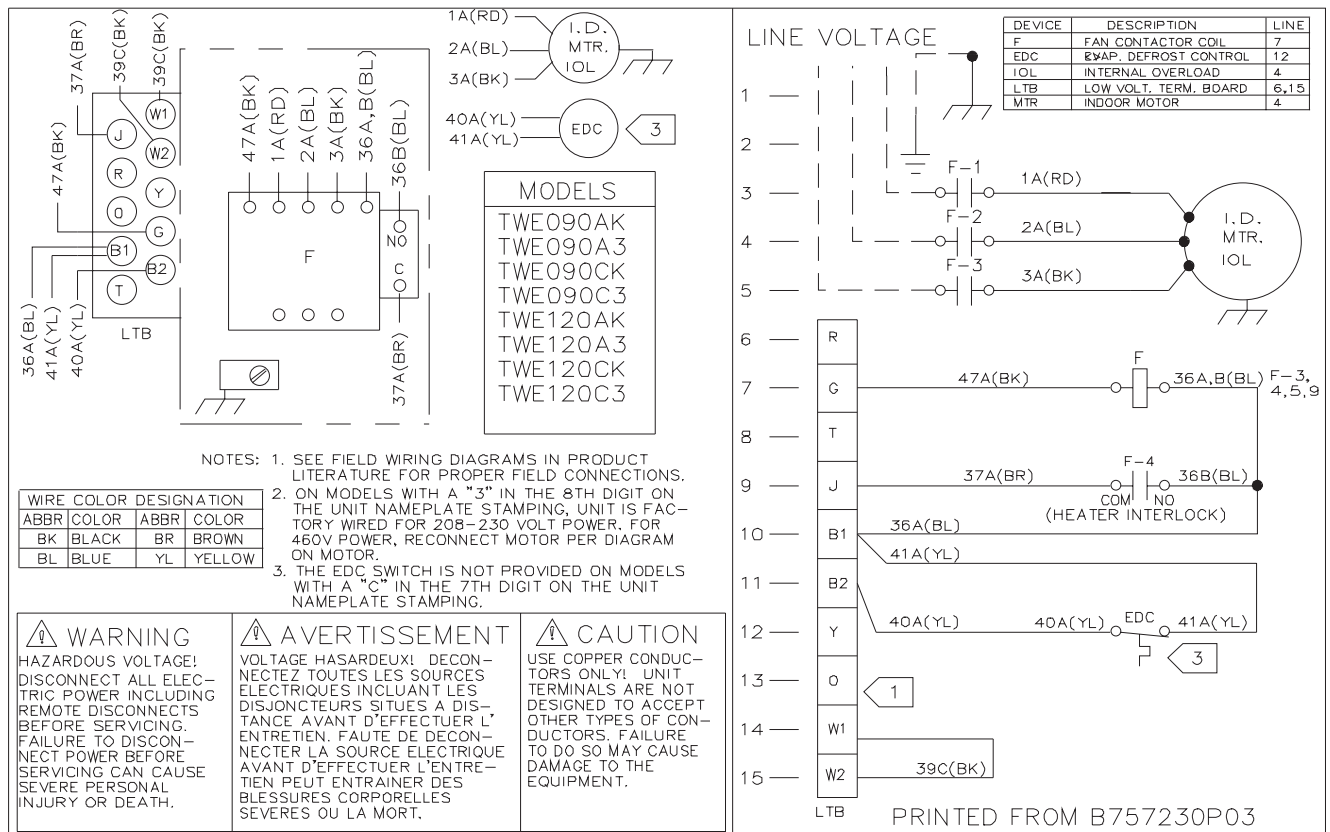

# Typical Wiring

# Condensing Unit

## Condensing Unit — Single Compressor

Typical wiring diagram. For specific wiring, see individual Service Facts.

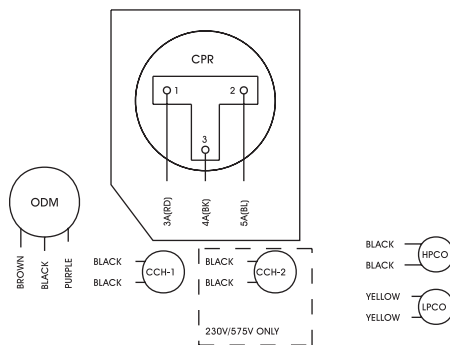
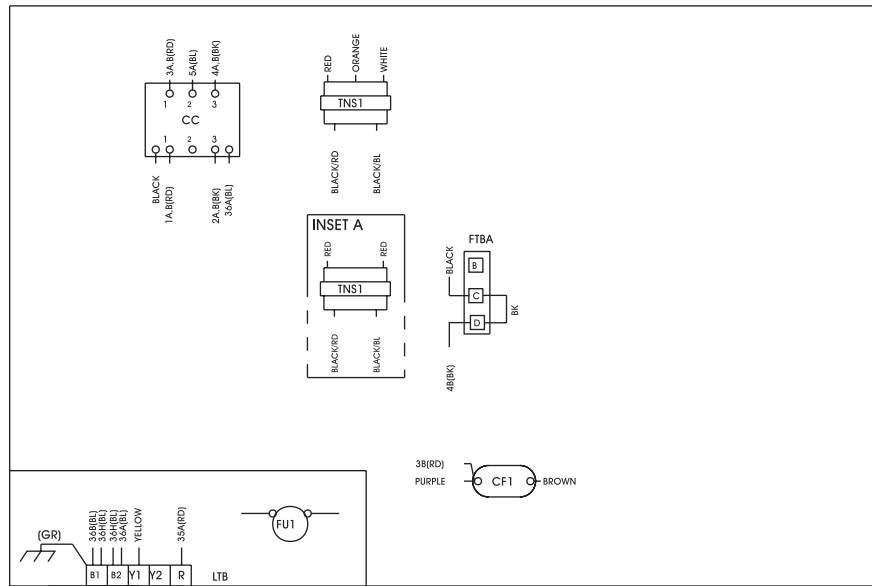

**NOTES:**

1. LOW VOLTAGE WIRING MUST BE 18 AWG MIN.
2. MAX. EXTERNAL LOW VOLTAGE LOAD 2.5 AMPS 24 V.A.C., DOES NOT INCLUDE ACCESSORIES BUT DOES INCLUDE INDOOR BLOWER RELAY.
3. SEE WIRING DIAGRAM WITH HEATER FOR DETAILS OF HEATER WIRING.
4. CONNECTIONS SHOWN ARE FOR 230V/60HZ/3PH. WHEN 208V/60HZ/3PH OPERATION IS REQUIRED:  
(A) AT TRANSFORMER REMOVE 1A(RD) WIRE FROM RED WIRE AND CONNECT TO ORANGE WIRE, THE RED WIRE MUST BE RE-TERMINATED TO AVOID ACCIDENTLY SHORTING.
5. IF EVAPORATOR DEFROST CONTROL (EDC) IS USED, REMOVE JUMPER BETWEEN 'B1' AND 'B2'.
6. CONNECTIONS FOR THE 230V/3PH/60HZ UNIT ARE SHOWN. FOR 480V, 480V, AND 575V UNITS SEE TRANSFORMER CONNECTIONS IN INSETS A AND B.

NOTE  
THREE PHASE MOTOR (S) FACTORY SUPPLIED IN THIS EQUIPMENT, PROTECTED UNDER PRIMARY SINGLE-PHASING CONDITIONS

TTA090A3  
TTA090A4  
TTA090AW  
TTA120A4  
TTA120AW  
TTA075AD  
TTA100AD  
TTA090AK  
TTA120AK

C757008P06

# Typical Wiring

# Condensing Unit

## Condensing Unit – Single Compressor

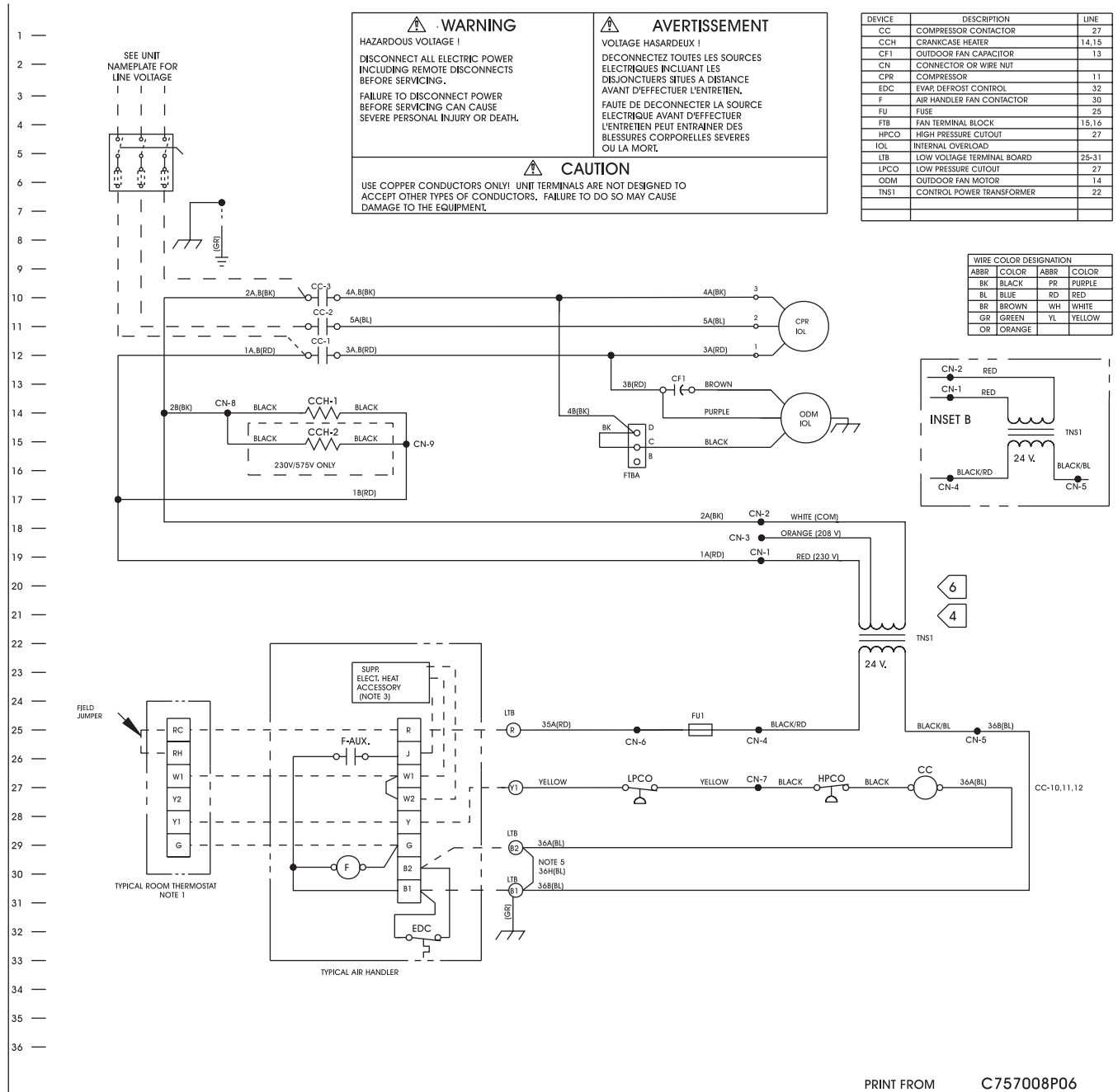

# Typical Wiring

# Condensing Unit

## Condensing Unit — Dual Compressor

Typical wiring diagram. For specific wiring, see individual Service Facts.

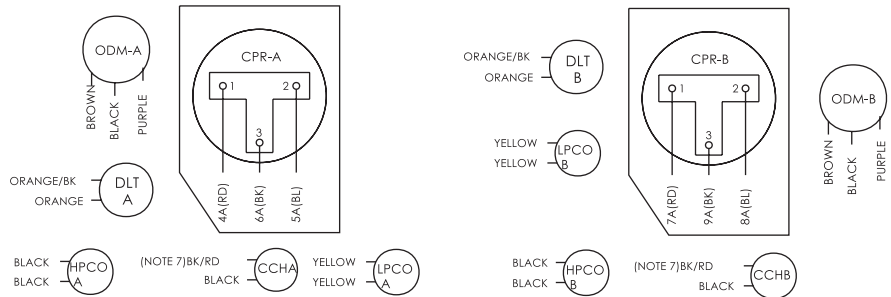
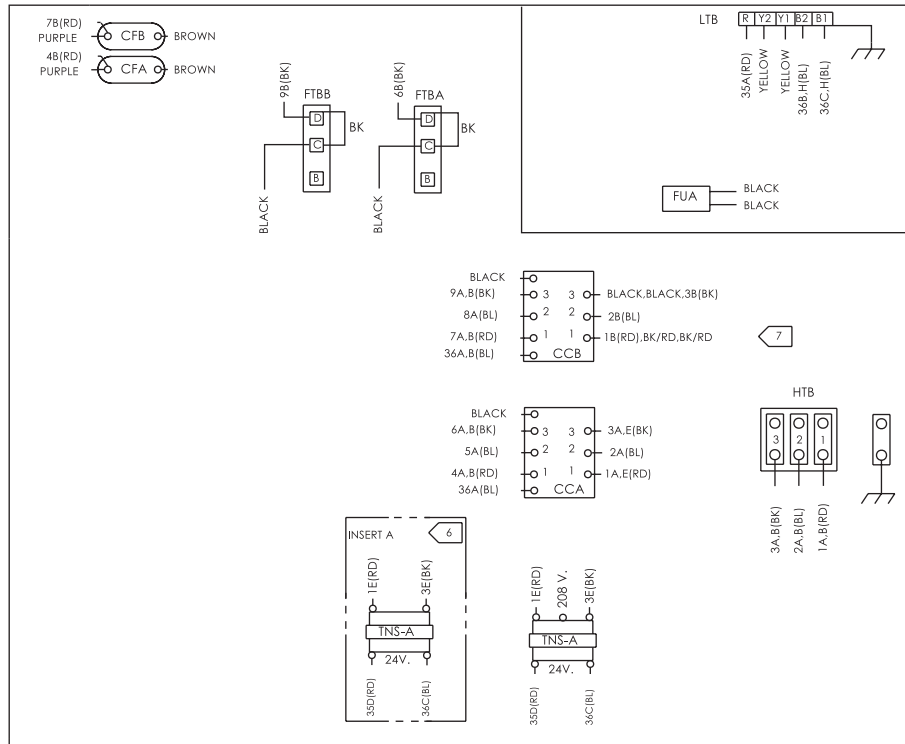

NOTE  
THREE PHASE MOTOR (S) FACTORY SUPPLIED IN THE EQUIPMENT. PROTECTED UNDER PRIMARY SINGLE-PHASING CONDITIONS

- NOTES:
1. LOW VOLTAGE WIRING MUST BE 18 AWG MIN.
  2. MAX. EXTERNAL LOW VOLTAGE LOAD 1.8 AMPS 24 V. A.C. DOES NOT INCLUDE ACCESSORIES BUT DOES INCLUDE INDOOR BLOWER RELAY.
  3. SEE WIRING DIAGRAM WITH HEATER FOR DETAILS OF HEATER WIRING.
  4. CONNECTIONS SHOWN ARE FOR 230V/60HZ/3PH. WHEN 208V/60HZ/3PH OPERATION IS REQUIRED:
    - [A] AT TRANSFORMER REMOVE 1E(RD) WIRE FROM TRANSFORMER AND CONNECT TO THE TERMINAL MARKED 208 V.
  5. IF EVAPORATOR DEFROST CONTROL (EDC) IS USED, REMOVE JUMPER BETWEEN "B1" AND "B2".
  6. CONNECTIONS FOR THE 230V/60HZ/3PH UNIT ARE SHOWN FOR 400V, 460V, AND 575V. UNIT SEE TRANSFORMER CONNECTIONS IN INSERT A AND B.
  7. AT ALL NOTE 7 REFERENCES, LEAD COLOR IS BK/BR ON TTA180/240BW MODELS, BK/YL ON TTA180B3 MODEL, AND BK/RD ON ALL OTHER MODELS.

- TTA155BD
- TTA180B3
- TTA180B4
- TTA180BW
- TTA180BK
- TTA200BD
- TTA240B4
- TTA240BW
- TTA240BK

C757164P01

# Typical Wiring

# Condensing Unit

## Condensing Unit — Dual Compressor

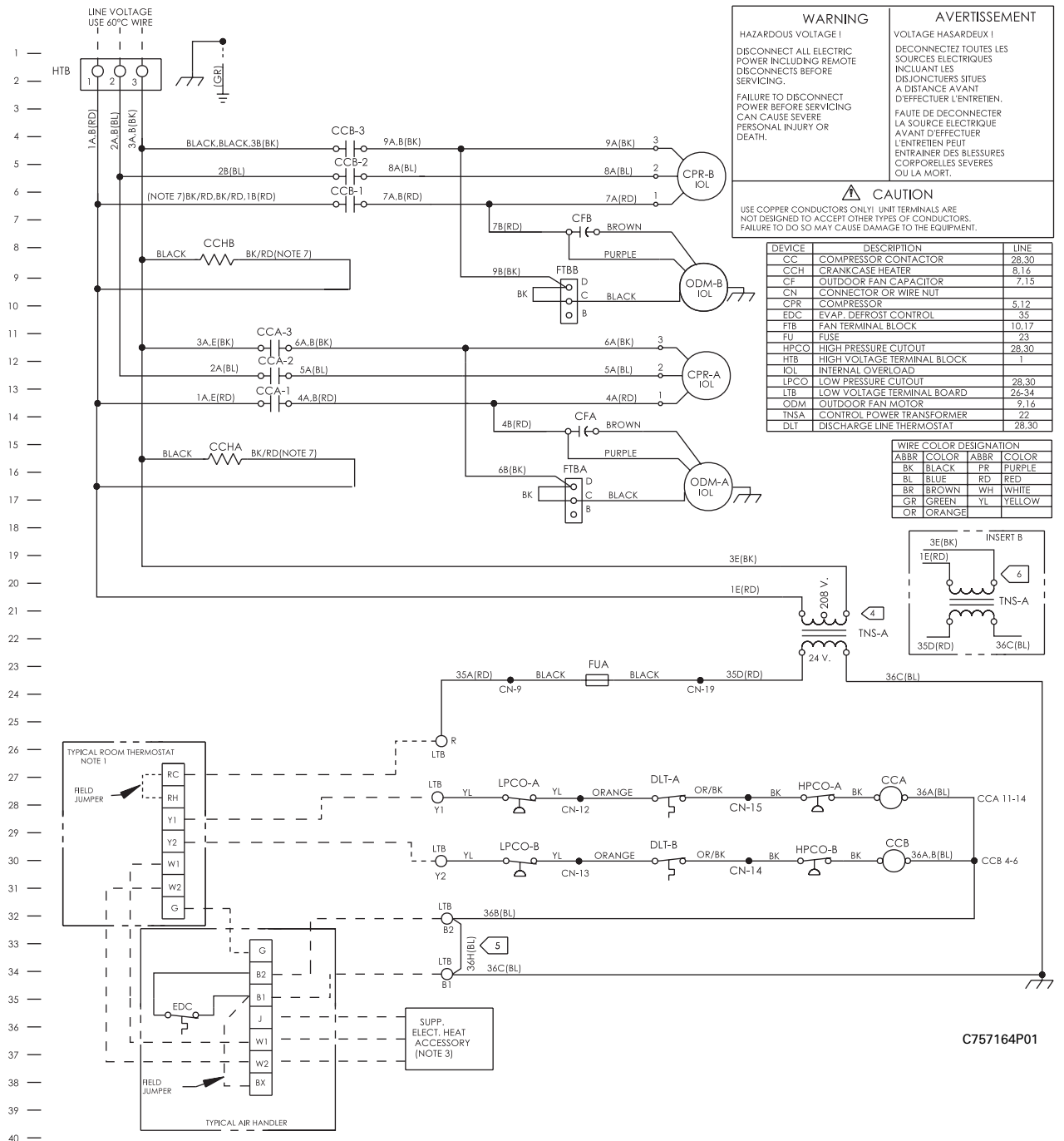

C757164P01

# Dimensional Data

**Figure DD-1 – TTA075 Condensing Units**  
All dimensions are in inches and millimeters.

TOP DISCHARGE AREA SHOULD BE UNRESTRICTED FOR 90°/2290 MINIMUM. UNIT SHOULD BE PLACED SO ROOF RUN-OFF WATER DOES NOT POUR DIRECTLY ON UNIT.

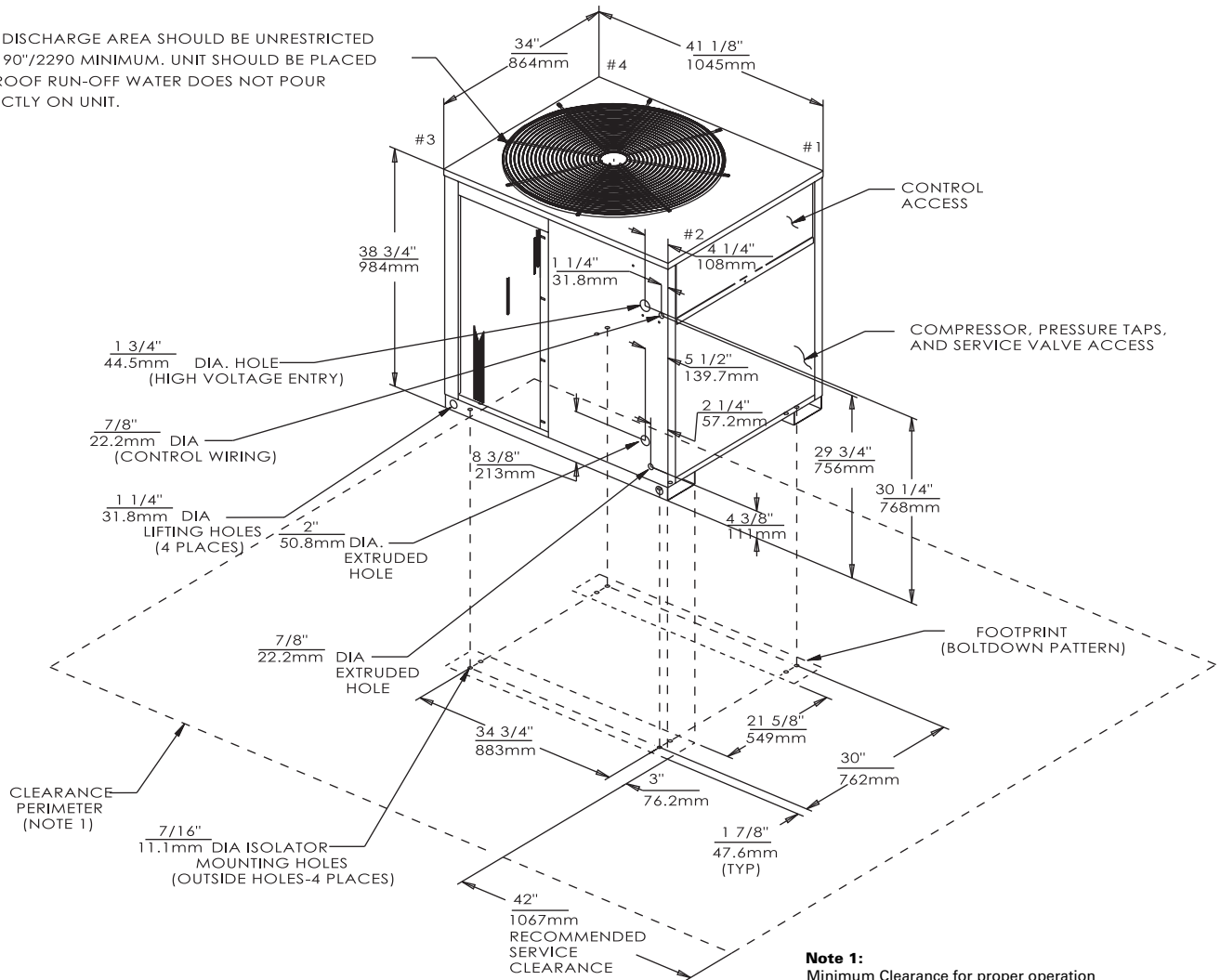

**Note 1:**  
Minimum Clearance for proper operation is 36 inches (914) from walls, shrubbery, privacy fences, etc. Minimum clearance between adjacent units is 72 inches (1829).

# Dimensional Data

**Figure DD-2 — TTA085A and 100A Condensing Units**  
All dimensions are in inches and millimeters.

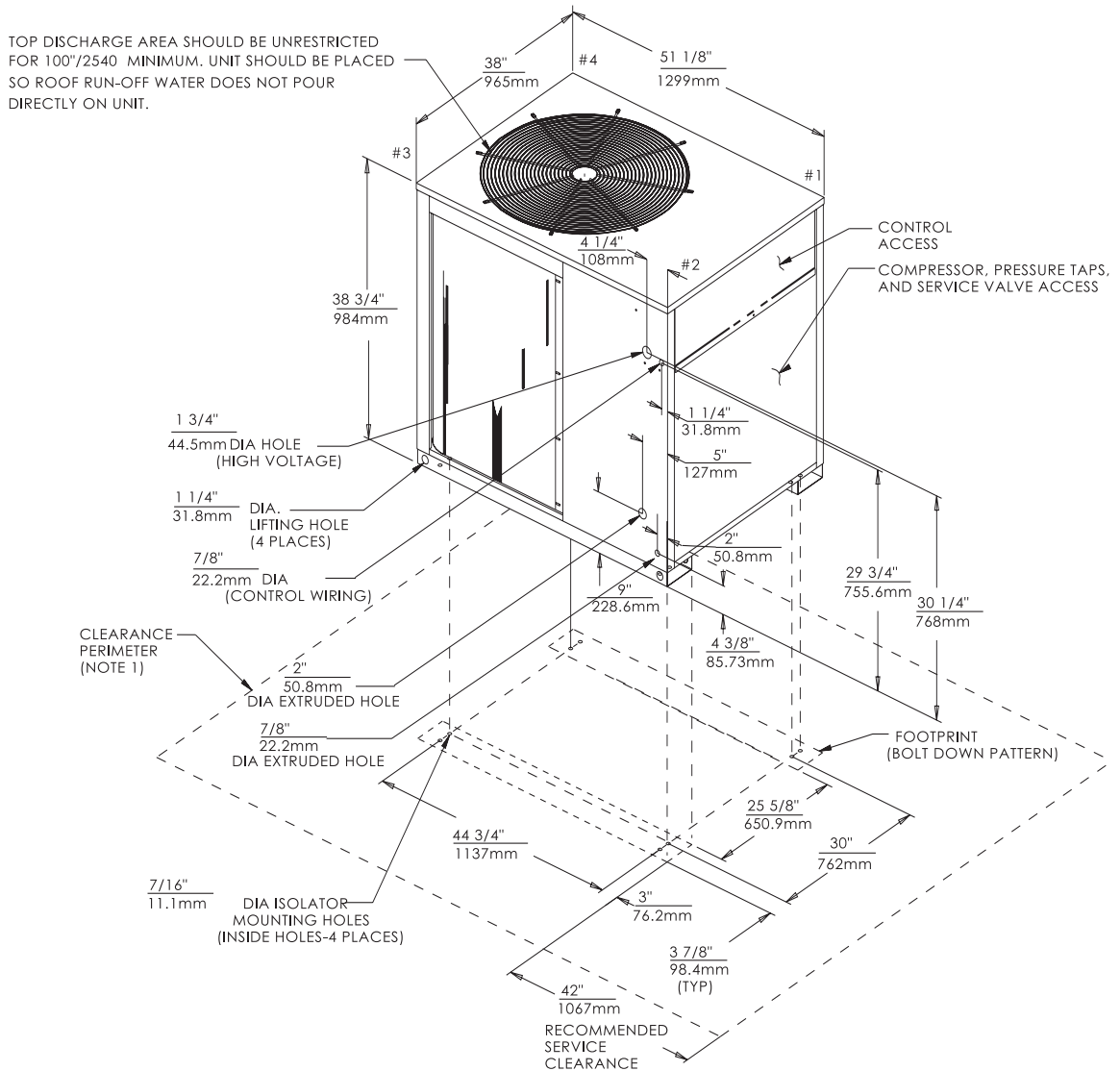

**Note 1:**  
Minimum Clearance for proper operation is 36 inches (914) from walls, shrubbery, privacy fences, etc. Minimum clearance between adjacent units is 72 inches (1829).

# Dimensional Data

**Figure DD-3 – TTA100C Condensing Units**

All dimensions are in inches and millimeters.

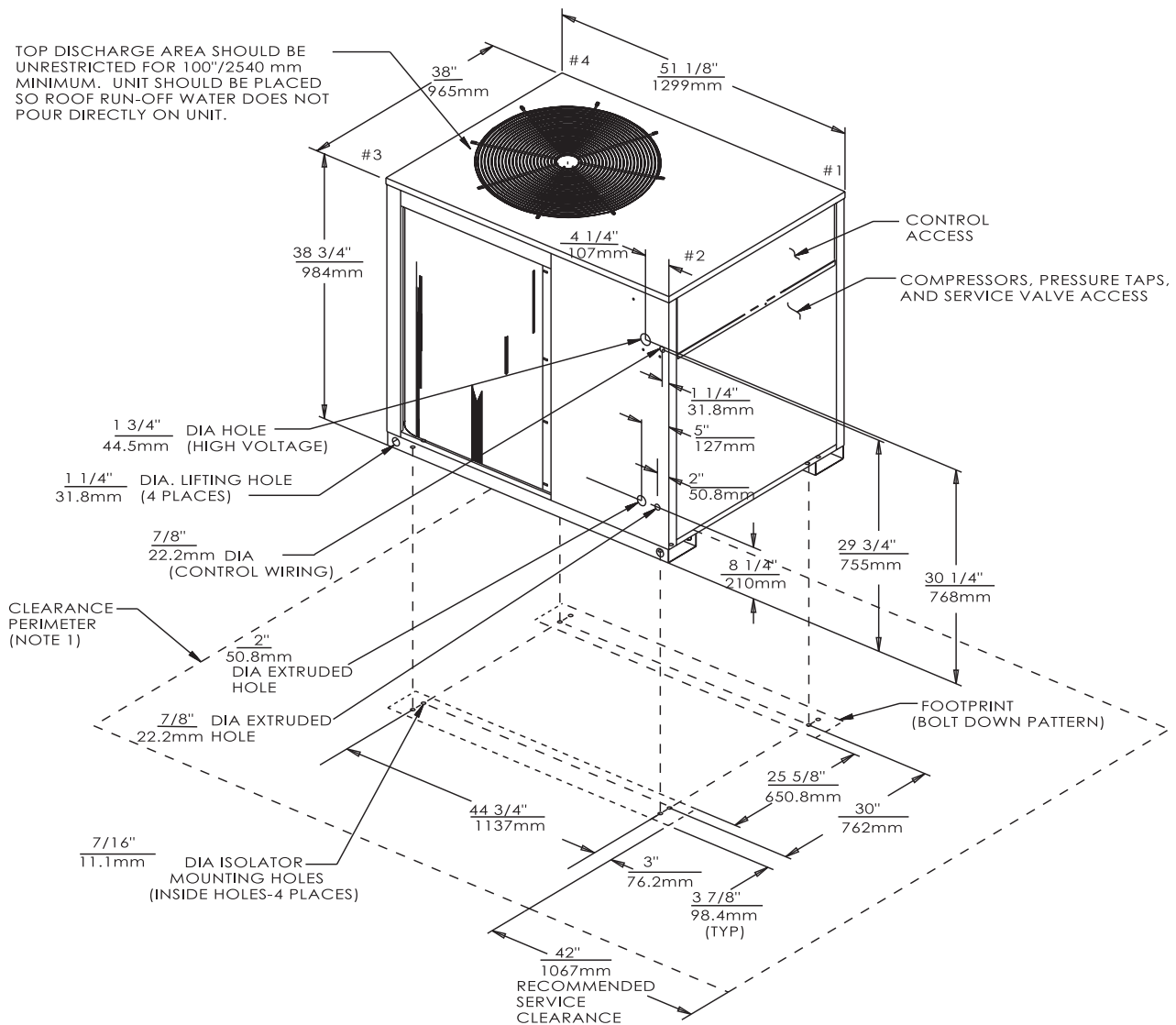

**Note 1:**  
Minimum Clearance for proper operation is 36 inches (914) from walls, shrubbery, privacy fences, etc. Minimum clearance between adjacent units is 72 inches (1829).



# Dimensional Data

**Figure DD-4 — TTA100B and TTA125B Condensing Units**

All dimensions are in inches and millimeters.

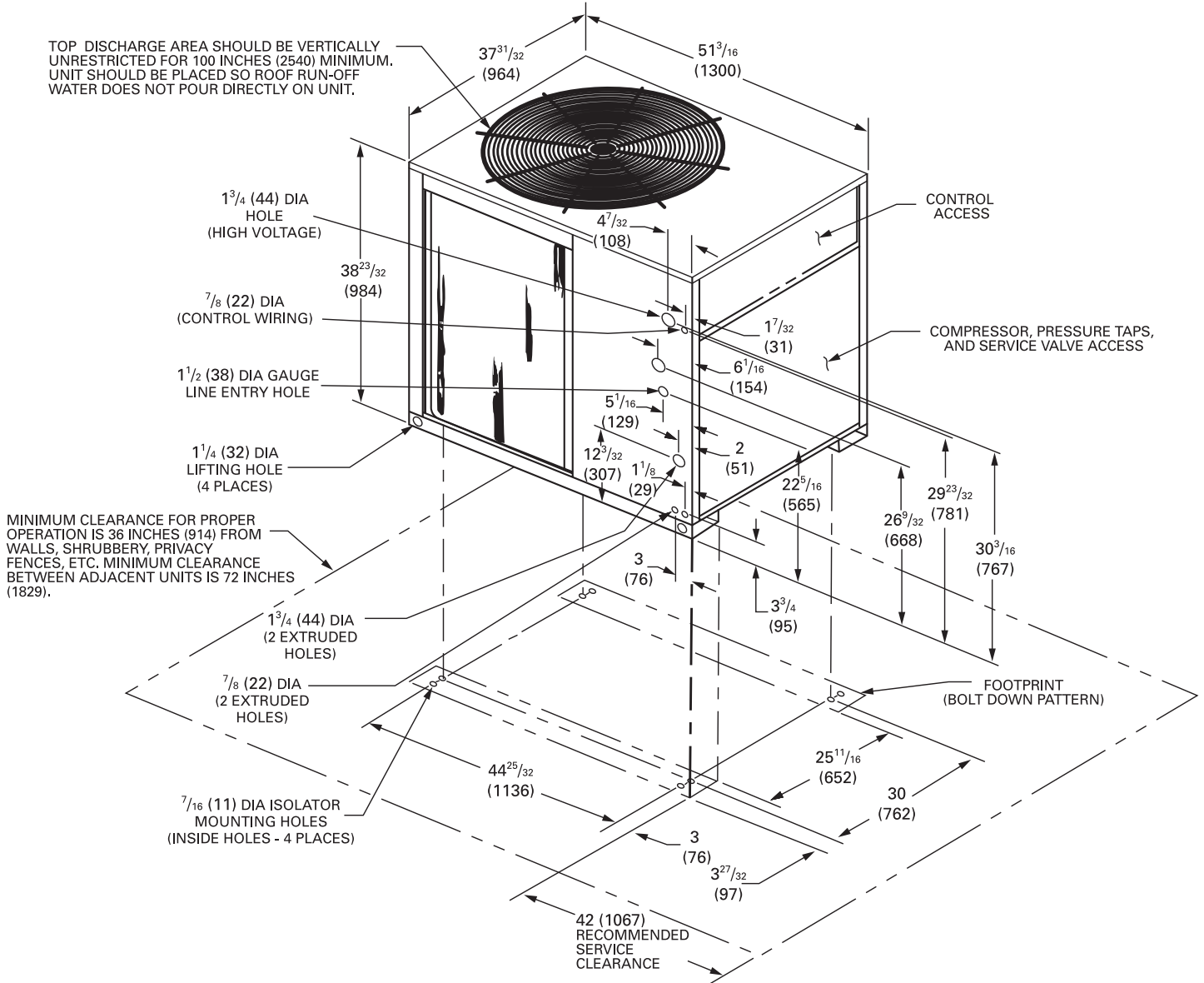

# Dimensional Data

**Figure DD-5— TTA155B Condensing Unit**  
All dimensions are in inches and millimeters.

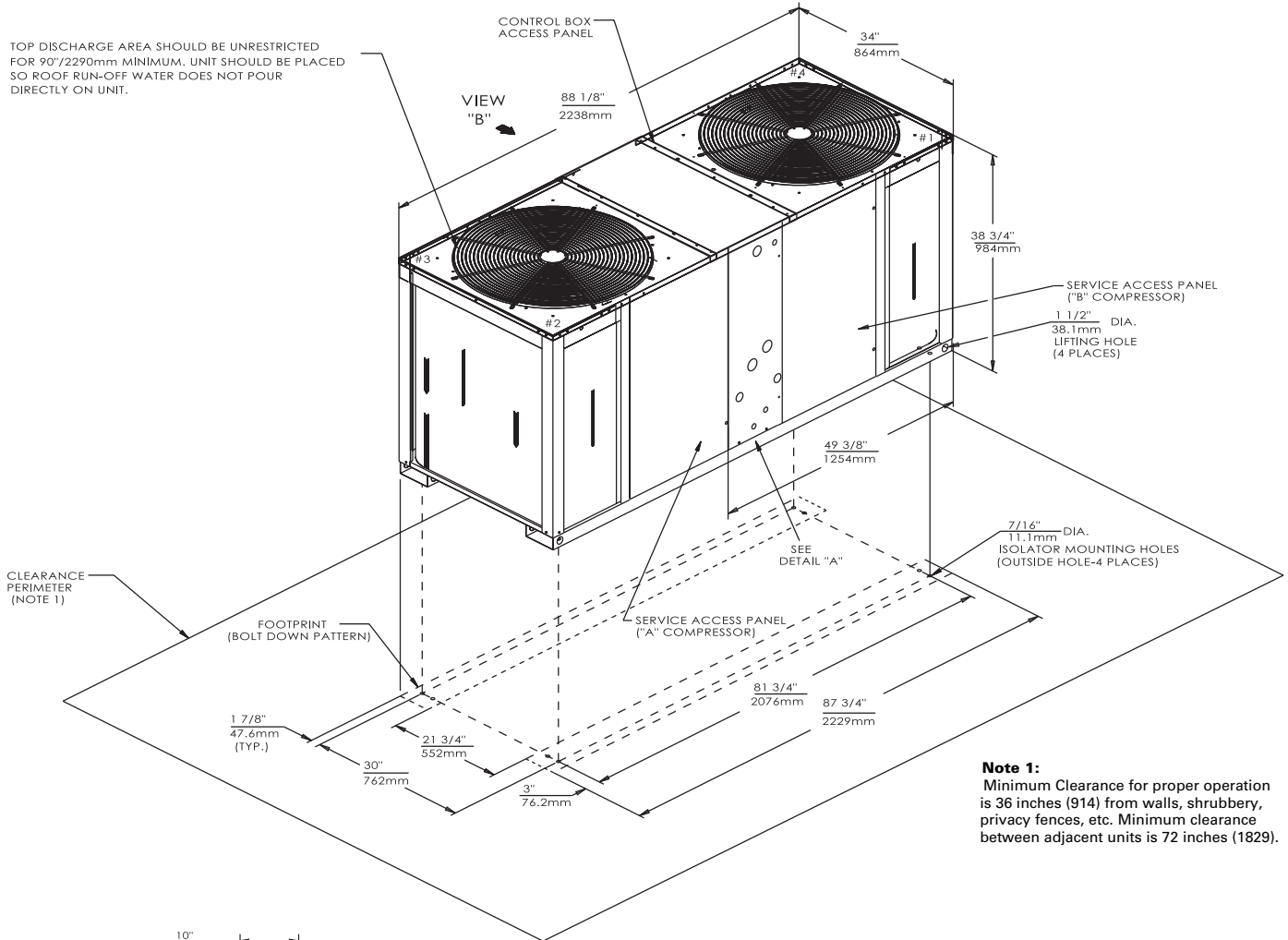

**Note 1:**  
Minimum Clearance for proper operation is 36 inches (914) from walls, shrubbery, privacy fences, etc. Minimum clearance between adjacent units is 72 inches (1829).

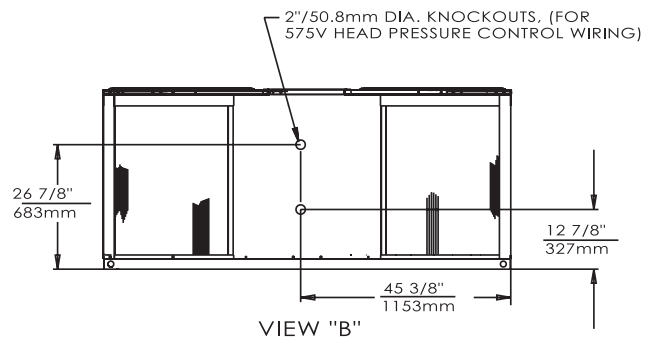
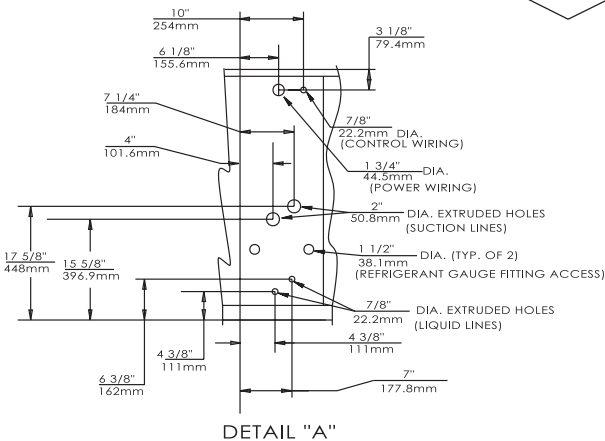

# Dimensional Data

**Figure DD-6 – TTA155C Condensing Units**

All dimensions are in inches and millimeters.

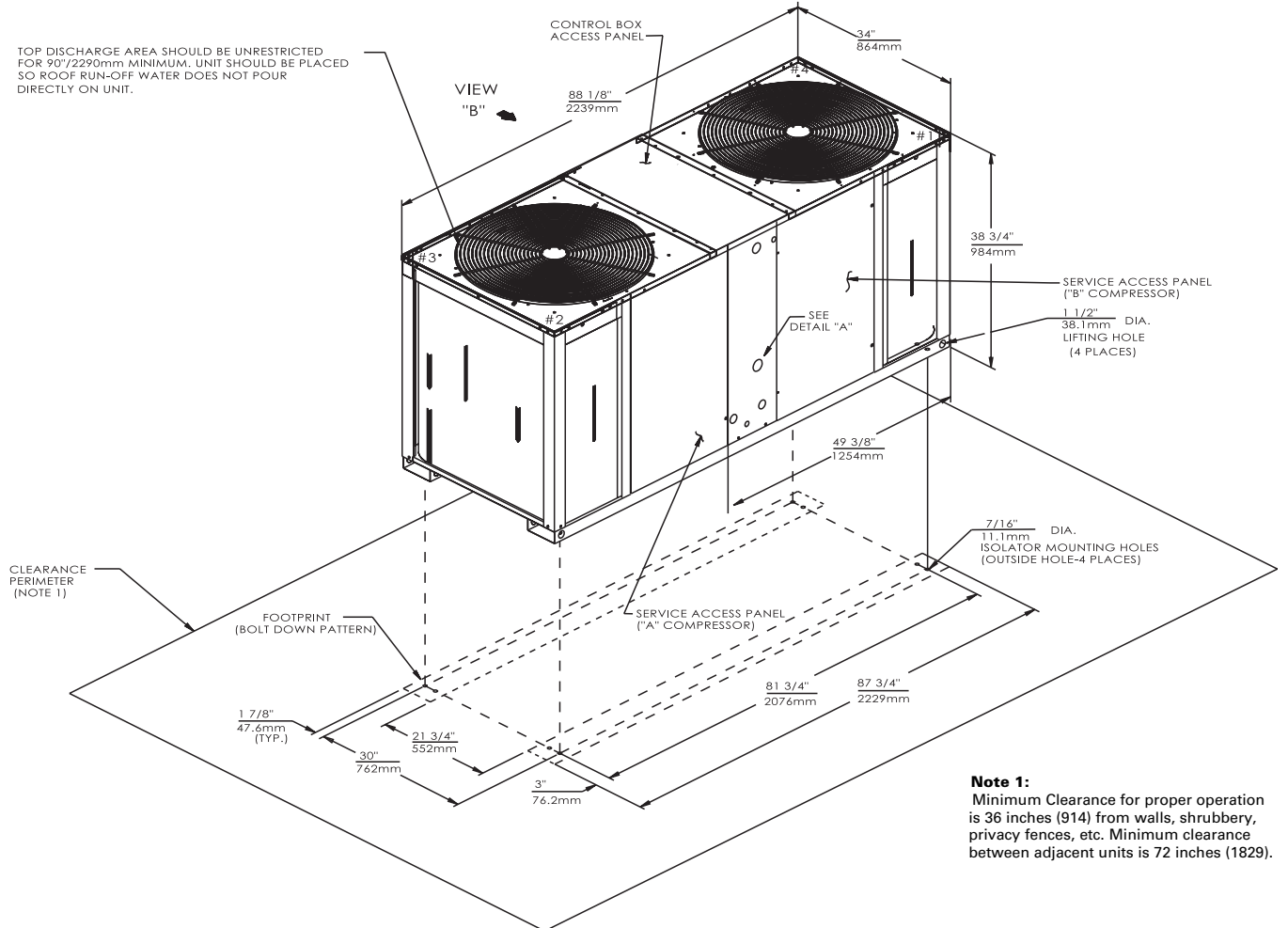

**Note 1:** Minimum Clearance for proper operation is 36 inches (914) from walls, shrubbery, privacy fences, etc. Minimum clearance between adjacent units is 72 inches (1829).

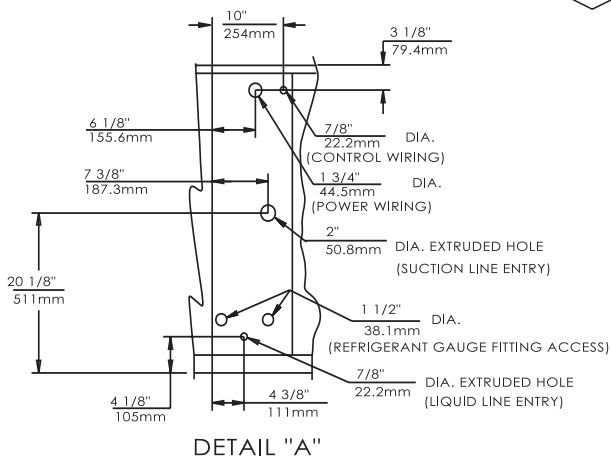

2"/50.8mm KNOCKOUT DIAMETER (575 VOLT HEAD PRESSURE CONTROL ACCESSORY WIRING ENTRY)

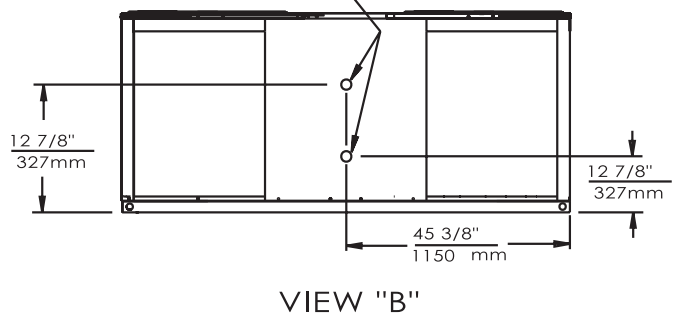

# Dimensional Data

**Figure DD-7 – TTA200B Condensing Unit**  
All dimensions are in inches and millimeters.

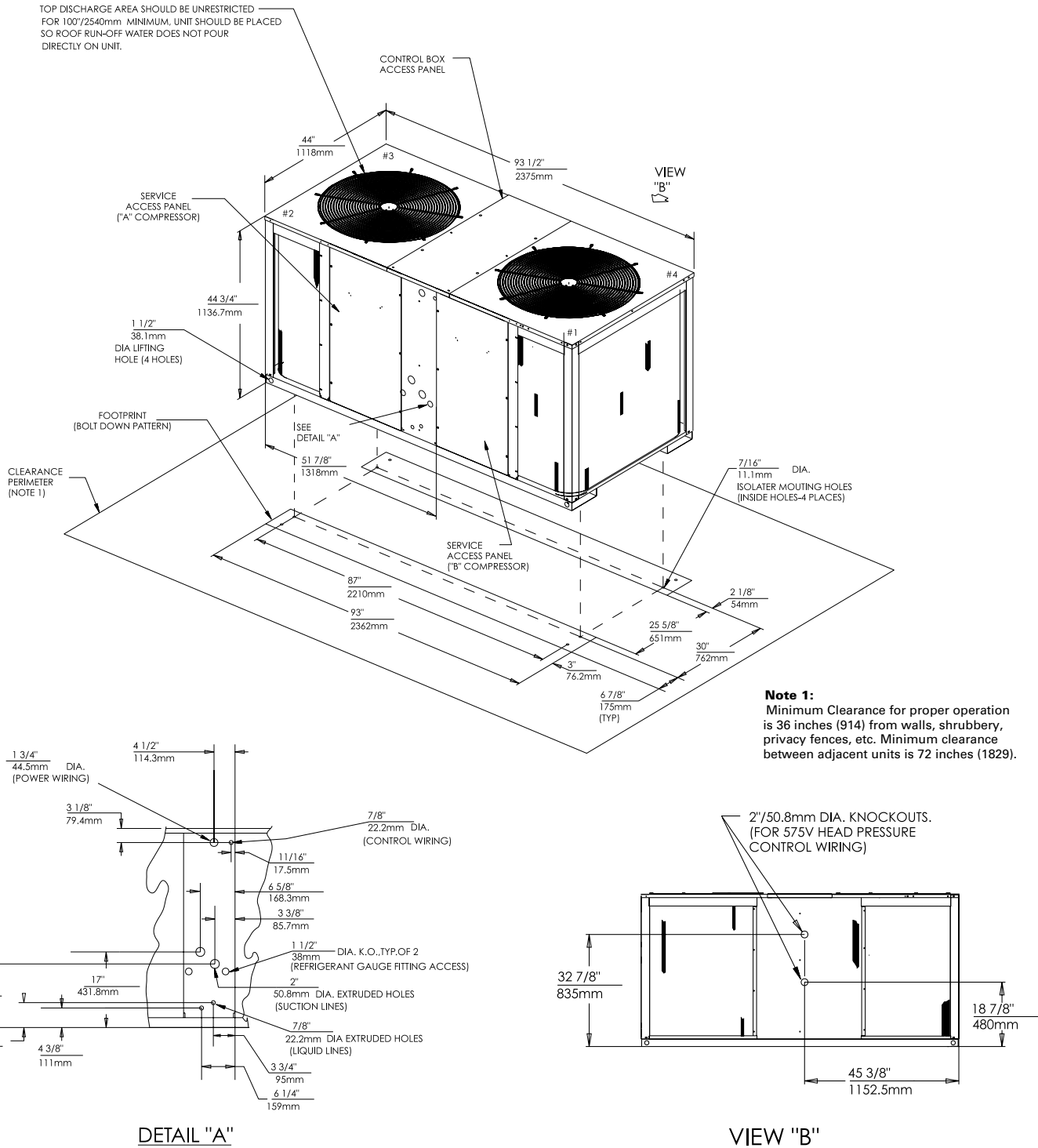

# Dimensional Data

**Figure DD-8 — TWE050A Air Handlers**

All dimensions are in inches and millimeters.

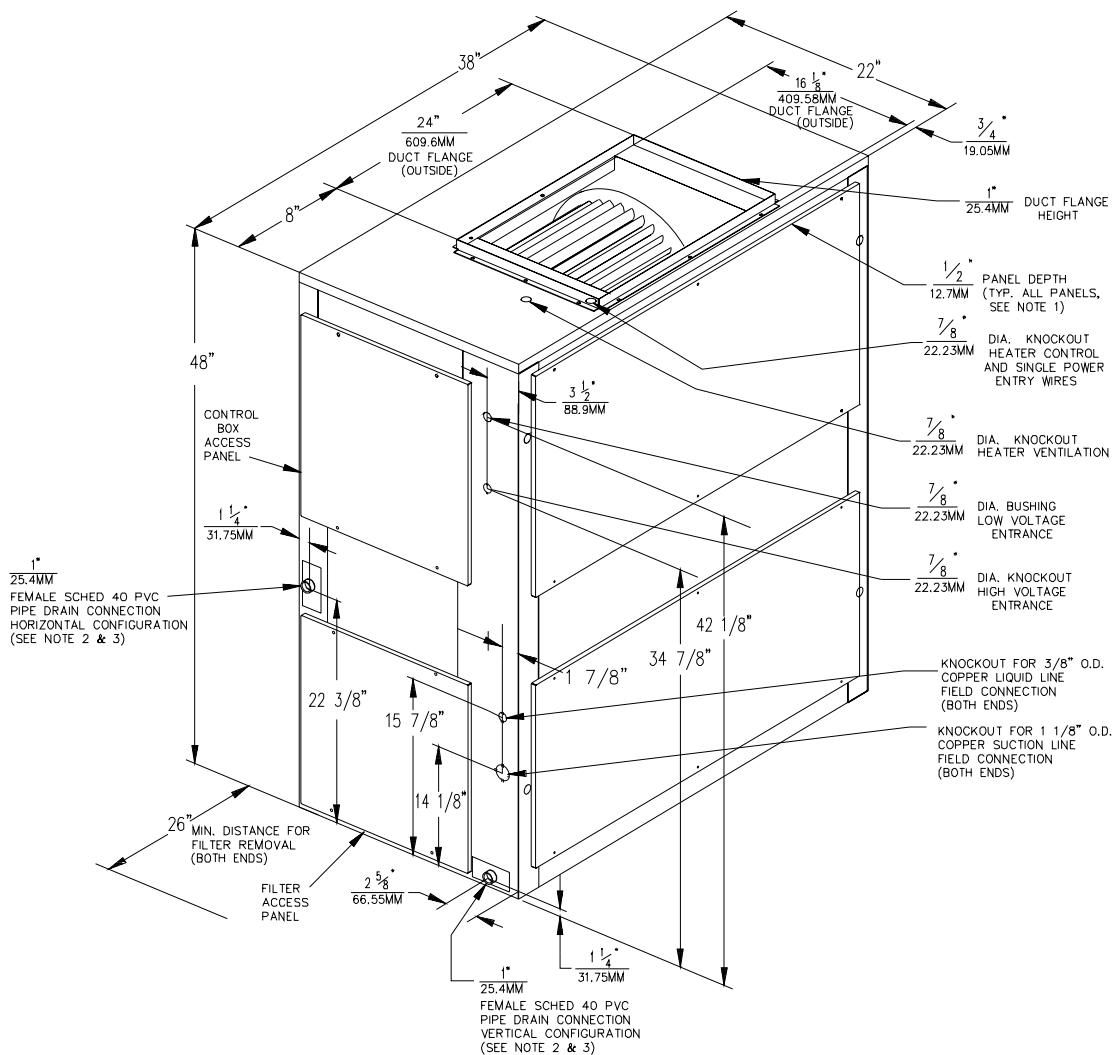

**Notes:**

1. Length, Width, and Height Dimensions do not include 1/2" (12.7mm) access panel depth.
2. Removable drain pan and attached drain connection may be installed on either end of unit in either the vertical or horizontal configuration. Plastic drain pan access plate on the end of unit opposite drain connection must be removed to slide drain pan out for cleaning. Access plate must be reinstalled after sliding drain pan back into unit.
3. If periodic drain pan cleaning is required, allow room for partial removal of pan on drain connection end of unit.

# Dimensional Data

**Figure DD-9 – TWE075A Air Handlers**

All dimensions are in inches and millimeters.

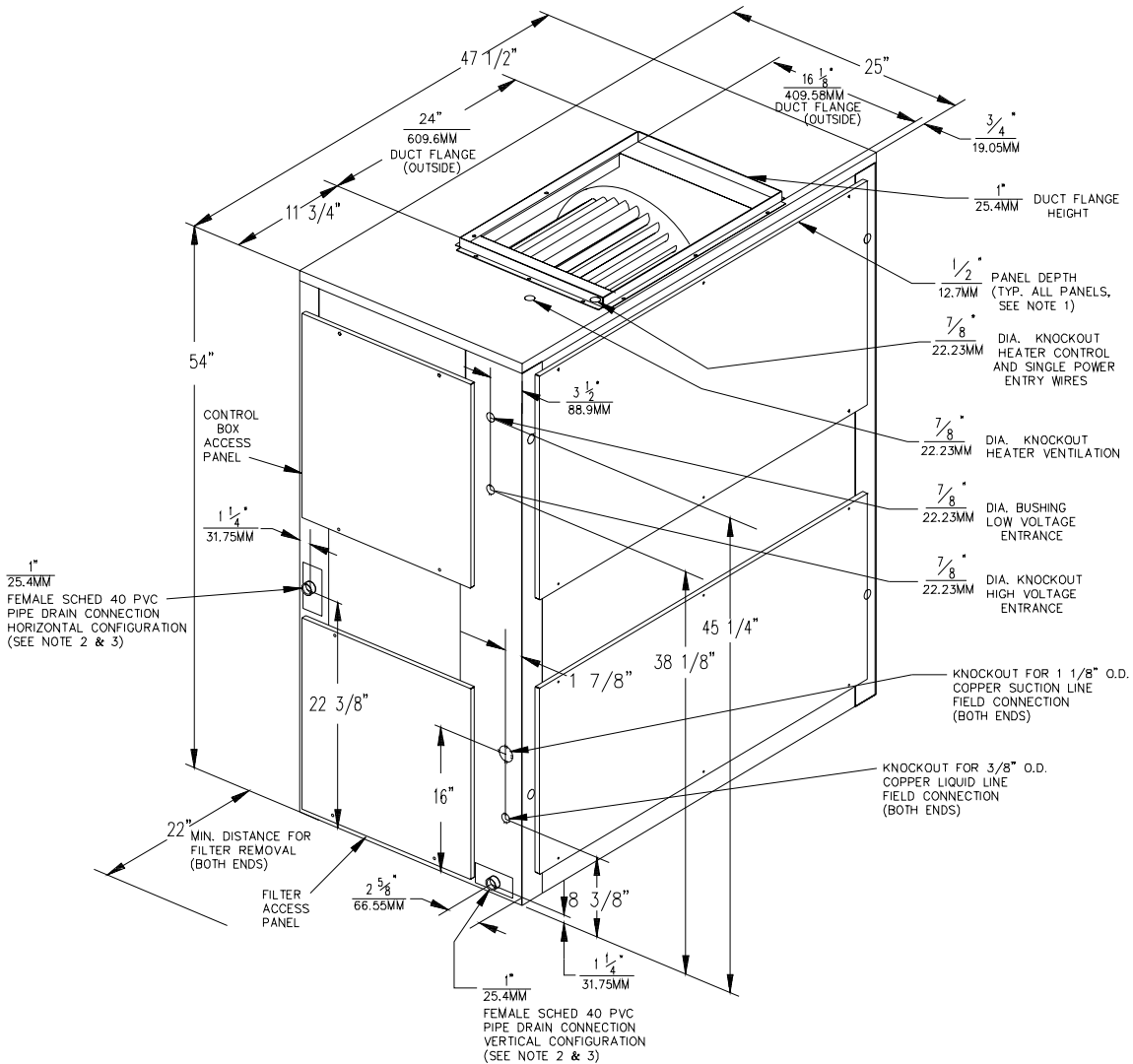

**Notes:**

1. Length, Width, and Height Dimensions do not include 1/2" (12.7mm) access panel depth.
2. Removable drain pan and attached drain connection may be installed on either end of unit in either the vertical or horizontal configuration. Plastic drain pan access plate on the end of unit opposite drain connection must be removed to slide drain pan out for cleaning. Access plate must be reinstalled after sliding drain pan back into unit.
3. If periodic drain pan cleaning is required, allow room for partial removal of pan on drain connection end of unit.

# Dimensional Data

**Figure DD-10 — TWE100A Air Handlers**

All dimensions are in inches and millimeters.

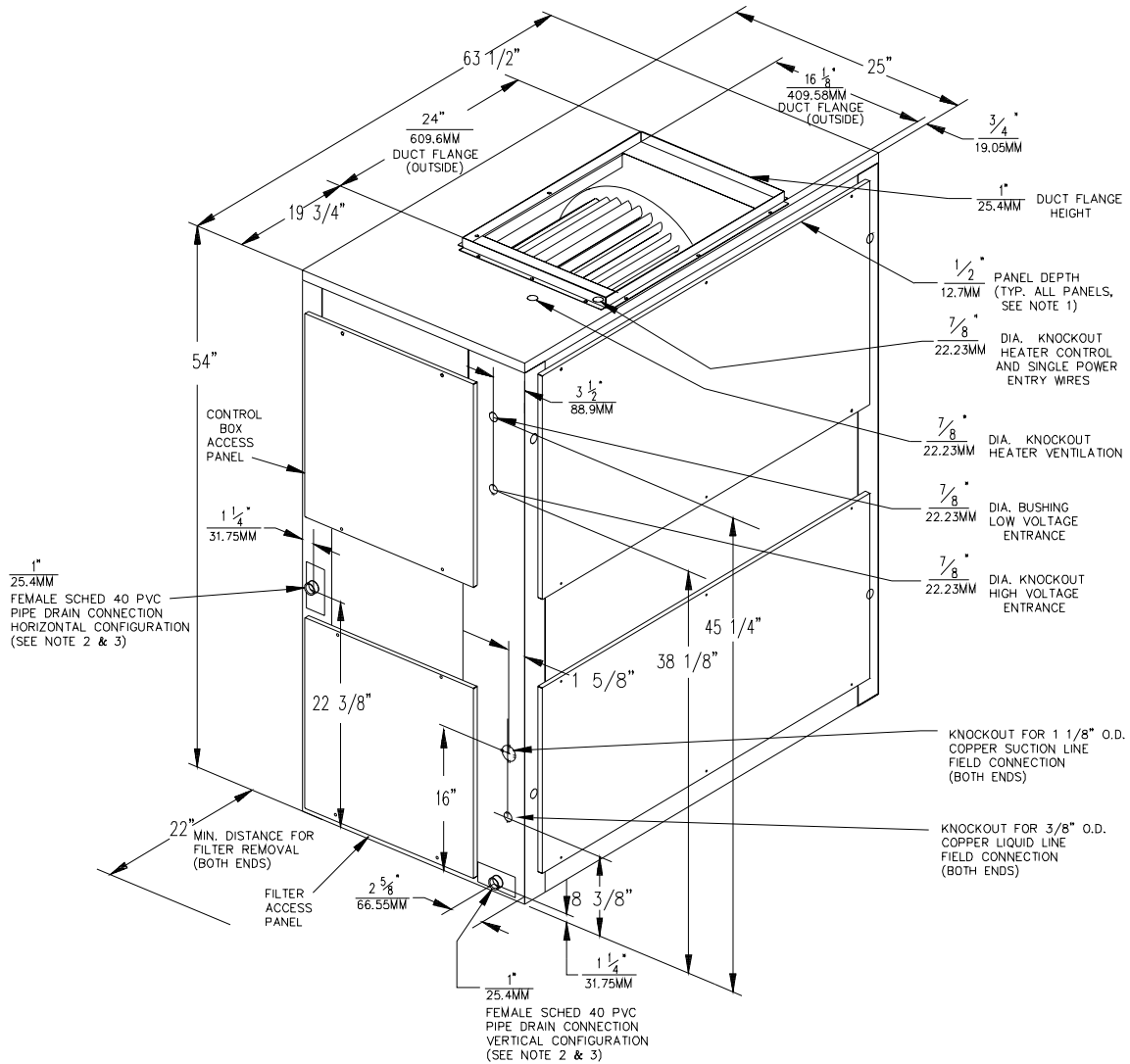

**Notes:**

1. Length, Width, and Height Dimensions do not include 1/2" (12.7mm) access panel depth.
2. Removable drain pan and attached drain connection may be installed on either end of unit in either the vertical or horizontal configuration. Plastic drain pan access plate on the end of unit opposite drain connection must be removed to slide drain pan out for cleaning. Access plate must be reinstalled after sliding drain pan back into unit.
3. If periodic drain pan cleaning is required, allow room for partial removal of pan on drain connection end of unit.

# Dimensional Data

**Figure DD-11 – TWE100B Air Handlers**

All dimensions are in inches and millimeters.

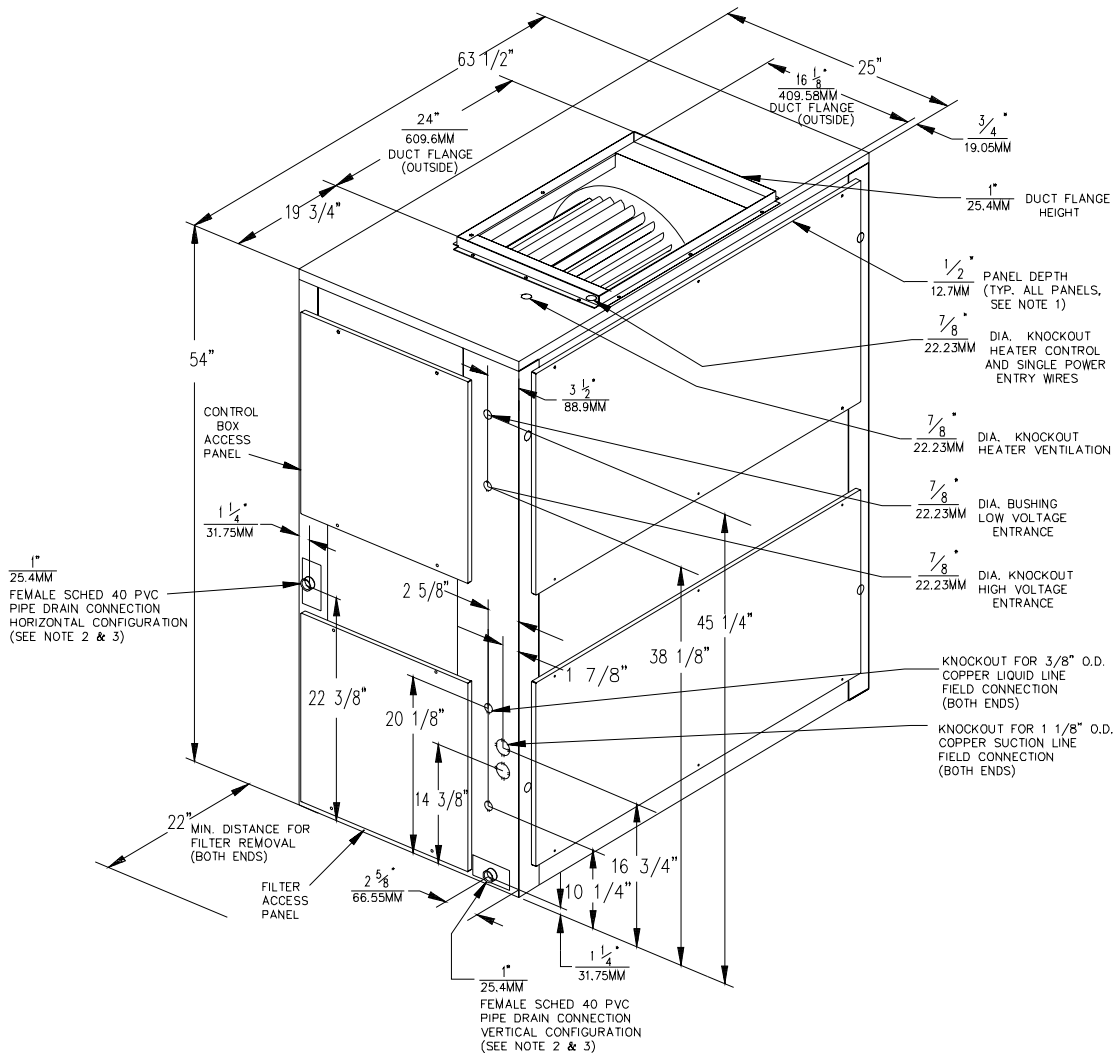

**Notes:**

1. Length, Width, and Height Dimensions do not include 1/2" (12.7mm) access panel depth.
2. Removable drain pan and attached drain connection may be installed on either end of unit in either the vertical or horizontal configuration. Plastic drain pan access plate on the end of unit opposite drain connection must be removed to slide drain pan out for cleaning. Access plate must be reinstalled after sliding drain pan back into unit.
3. If periodic drain pan cleaning is required, allow room for partial removal of pan on drain connection end of unit.



# Dimensional Data

Figure DD-12 — TWE050A, 075A, 100A and TWE100B Air Handlers

All dimensions are in inches and millimeters.

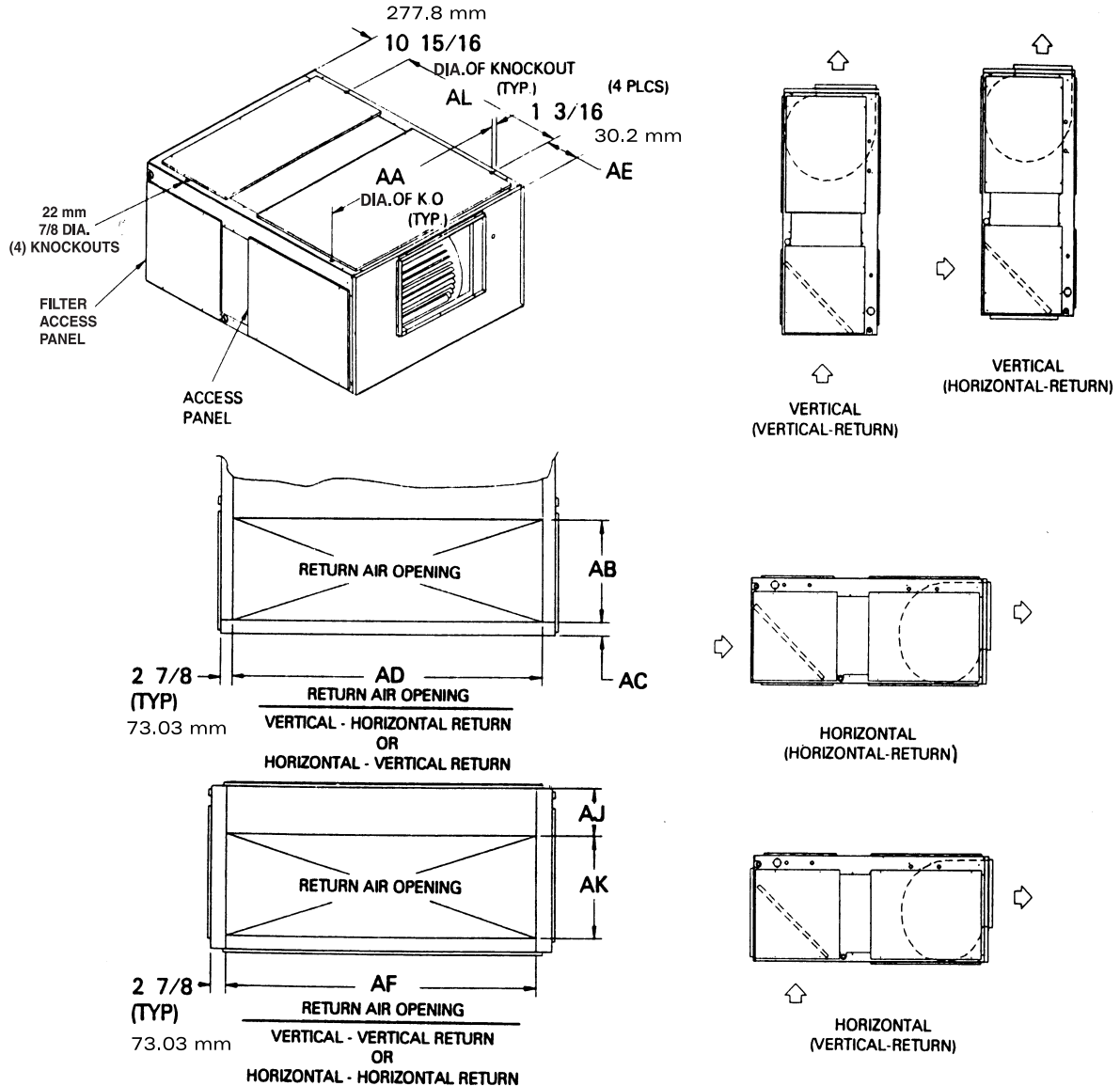

Table DD-1 — Air Handler Dimensions — in. (mm)

Model No.	AA	AB	AC	AD	AE	AF	AJ	AK	AL
TWE050A	35 5/8 (905)	12 1/16 (306.4)	1 5/8 (41.3)	32 1/4 (819.2)	2 15/16 (74.6)	32 1/4 (819.2)	7 13/16 (198.4)	12 3/8 (314.3)	34 9/16 (878)
TWE075A	45 1/8 (1146.2)	16 (406.4)	1 11/16 (42.9)	41 15/16 (1065.2)	6 5/8 (168.3)	41 3/4 (1060.5)	7 (177.8)	16 (406.4)	36 7/8 (936.6)
TWE100A	61 1/8 (1552.6)	16 (406.4)	1 11/16 (42.9)	57 15/16 (1471.6)	6 5/8 (168.3)	57 13/16 (1468.4)	7 (177.8)	16 (406.4)	36 7/8 (936.6)
TWE100B	61 1/8 (1552.6)	16 (406.4)	1 11/16 (42.9)	57 15/16 (1471.6)	6 5/8 (168.3)	57 13/16 (1468.4)	7 (177.8)	16 (406.4)	36 7/8 (936.6)





# Dimensional Data

**Figure DD-15 – TWE155B and 200B Air Handlers**  
All dimensions are in inches and millimeters.

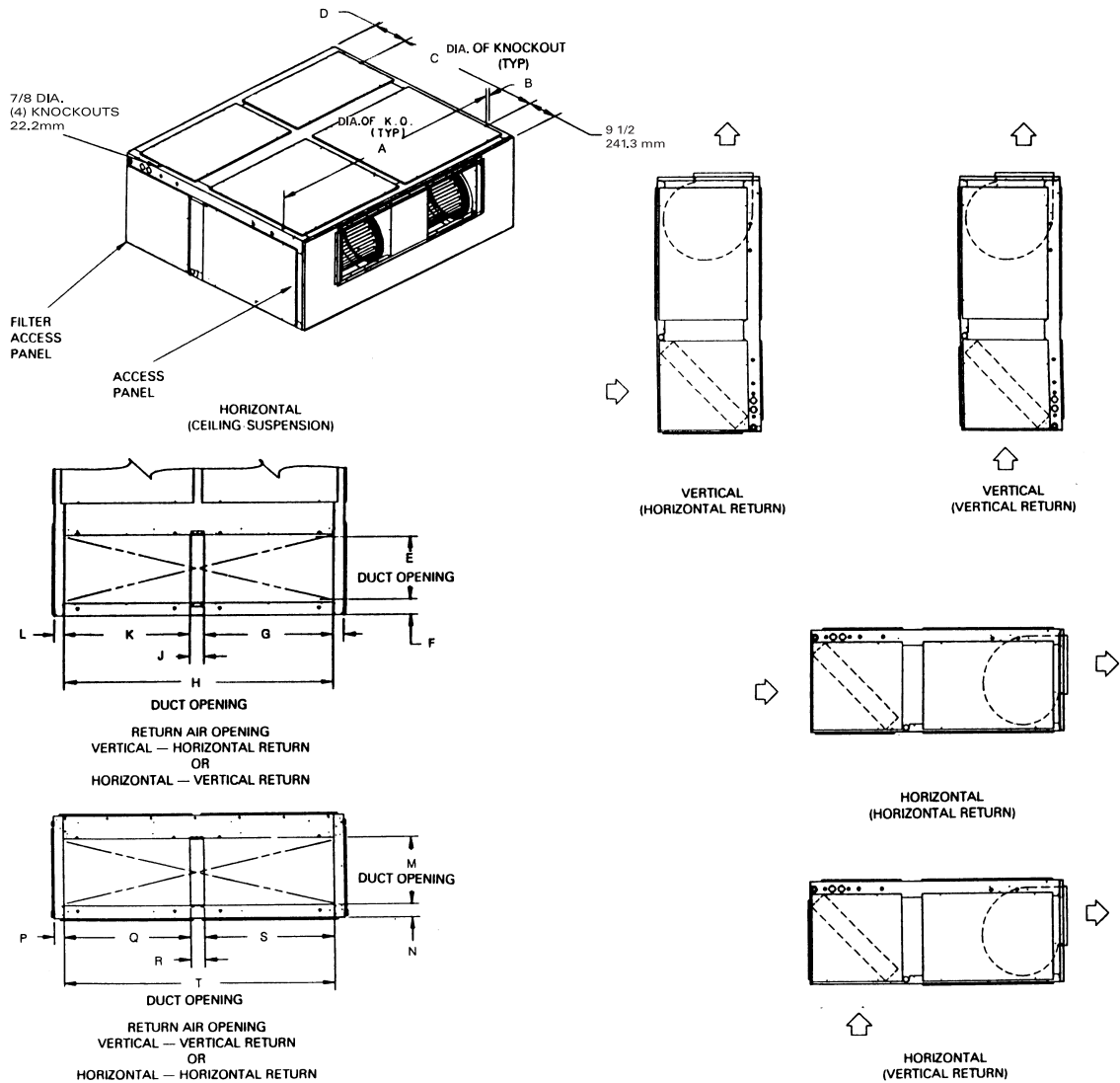

**Table DD-2 – Air Handler Dimensions – in. (mm)**

Model No.	A	B	C	D	E	F	G	H	J
TWE155B	77 1/4 (1962.2)	1 3/16 (30.2)	48 (1219.2)	11 7/16 (290.5)	18 (457.2)	3 3/8 (85.7)	35 1/16 (890.6)	73 7/8 (1876.4)	3 3/4 (95.3)
TWE200B	89 1/4 (2267)	1 11/16 (42.9)	50 13/16 (1290.6)	11 1/2 (292.1)	20 1/8 (511.2)	3 1/16 (77.8)	39 1/8 (993.8)	82 7/8 (2105)	4 9/16 (115.9)

**Table DD-2 – Air Handler Dimensions – in. (mm) (Continued)**

Model No.	K	L	M	N	P	Q	R	S	T
TWE155B	35 1/16 (890.6)	2 13/16 (71.4)	18 (457.2)	3 9/16 (90.5)	2 7/8 (73)	35 1/16 (890.6)	3 3/4 (95.3)	35 1/16 (890.6)	73 3/8 (1863.7)
TWE240B	39 1/8 (993.8)	4 7/8 (123.8)	20 (508)	3 (76.2)	4 13/16 (122.2)	39 1/8 (993.8)	4 9/16 (115.9)	39 1/8 (993.8)	82 7/8 (2105)

# Dimensional Data

**Figure 16 — Electric Heater for TWE050, 075, 100 Air Handlers**

All dimensions are in inches and millimeters.

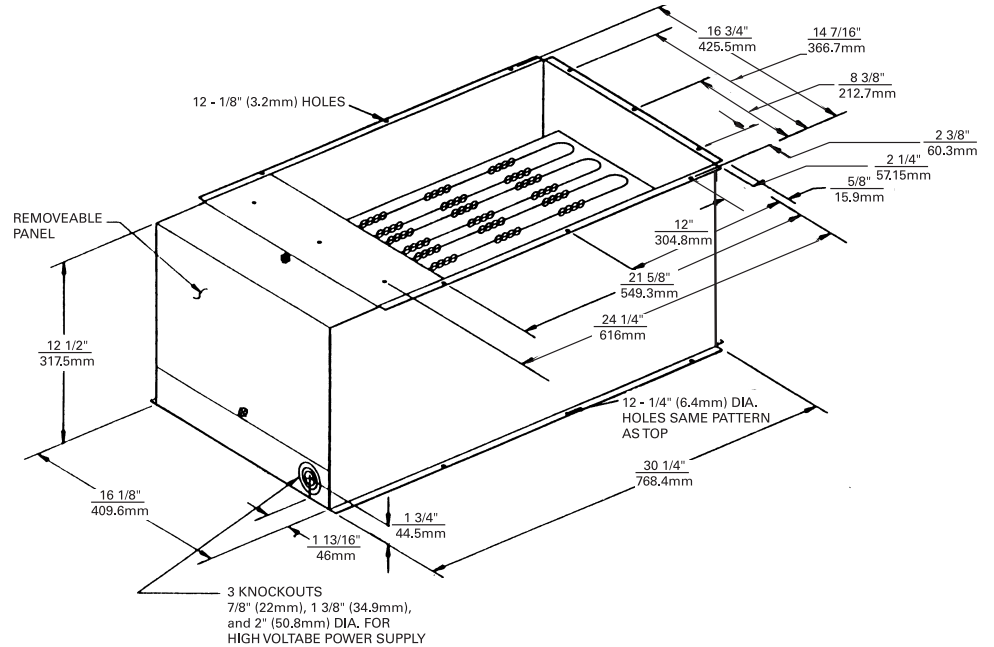

**Figure DD-17 — Electric Heater for TWE155 and 200 Air Handlers**

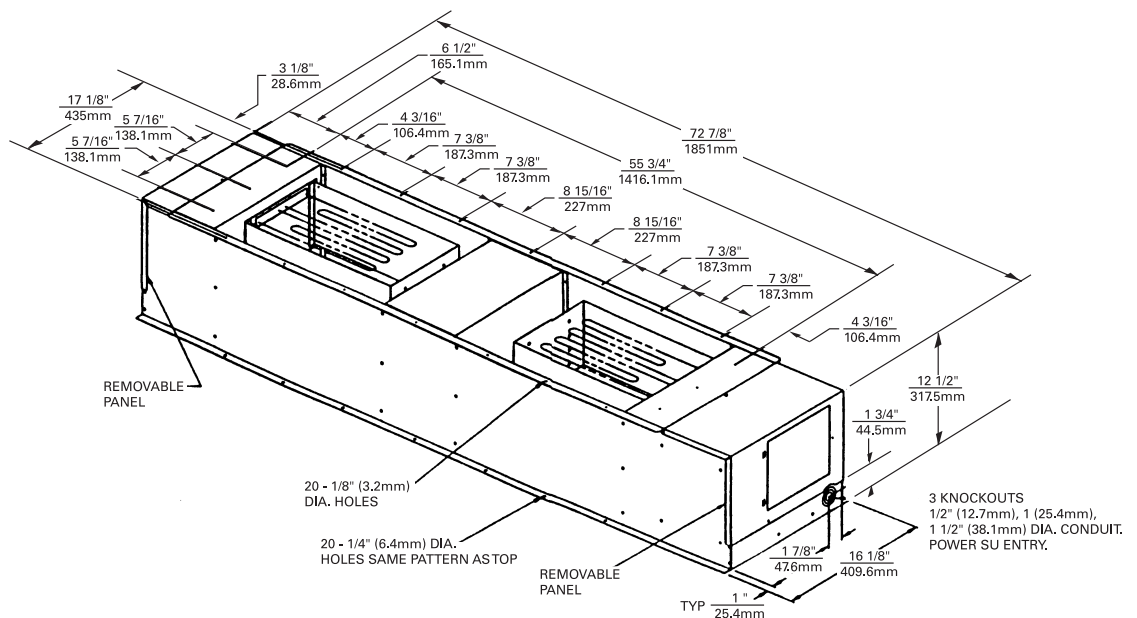

# Dimensional Data

**Table DD-3 — Discharge Plenum And Grille Dimensions — in. (mm)**

Model	Model No.	A	B	C
TWE050	BAYPLNM015	37 <sup>15</sup> / <sub>16</sub> (963.6)	21 <sup>15</sup> / <sub>16</sub> (557.2)	28 (711.2)
TWE075	BAYPLNM016	47 <sup>1</sup> / <sub>2</sub> (1206.5)	25 (635)	28 (711.2)
TWE100	BAYPLNM017	63 <sup>1</sup> / <sub>2</sub> (1612.9)	25 (635)	28 (711.2)

**Table DD-4 — Discharge Plenum And Grille Dimensions — in. (mm)  
For Use with Electric Heat**

Model	Model No.	A	B	C
TWE050	BAYPLNM025	37 <sup>15</sup> / <sub>16</sub> (963.6)	21 <sup>15</sup> / <sub>16</sub> (557.2)	29 (736.6)
TWE075	BAYPLNM026	47 <sup>1</sup> / <sub>2</sub> (1206.5)	25 (635)	29 (736.6)
TWE100	BAYPLNM027	63 <sup>1</sup> / <sub>2</sub> (1612.9)	25 (635)	29 (736.6)
TWE155	BAYPLNM028	79 <sup>1</sup> / <sub>2</sub> (2019.3)	27 <sup>11</sup> / <sub>16</sub> (703.3)	35 (889)
TWE200	BAYPLNM029	92 <sup>1</sup> / <sub>2</sub> (2349.5)	30 <sup>7</sup> / <sub>16</sub> (773.1)	35 (889)

**Figure DD-18 — Discharge Plenum and Grille**

All dimensions are in inches and millimeters.

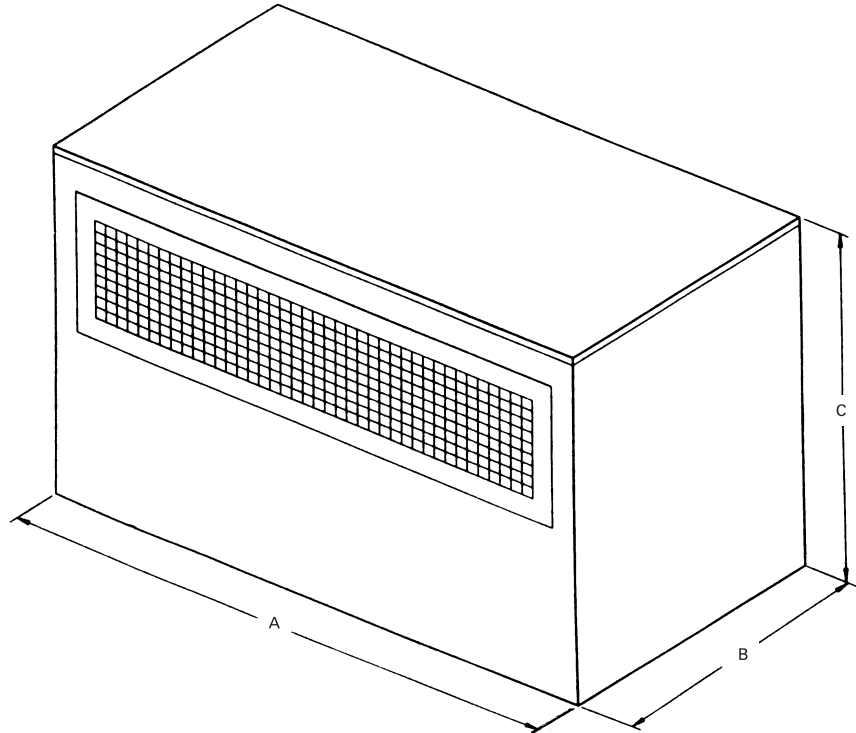

**Table DD-5 — Subbase Dimensions — in. (mm)**

Model	Model No.	A	B
TWE050	BAYBASE001	38 (965.2)	22 (558.8)
TWE075	BAYBASE002	47 <sup>1</sup> / <sub>2</sub> (1206.5)	25 (635)
TWE100	BAYBASE003	63 <sup>1</sup> / <sub>2</sub> (1612.9)	25 (635)
TWE155	BAYBASE004	79 <sup>1</sup> / <sub>2</sub> (2019.3)	27 <sup>5</sup> / <sub>8</sub> (701.7)
TWE200	BAYBASE005	92 <sup>1</sup> / <sub>2</sub> (2349.5)	30 <sup>7</sup> / <sub>16</sub> (773.1)

**Figure DD-19 — Subbase**

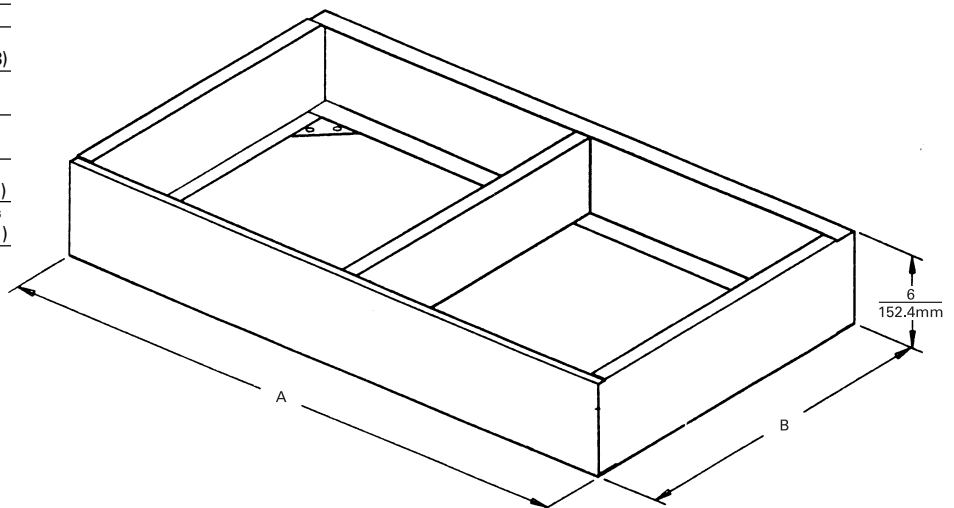

# Dimensional Data

**Figure DD-20 — Hot Water Coil**

All dimensions are in inches and millimeters.

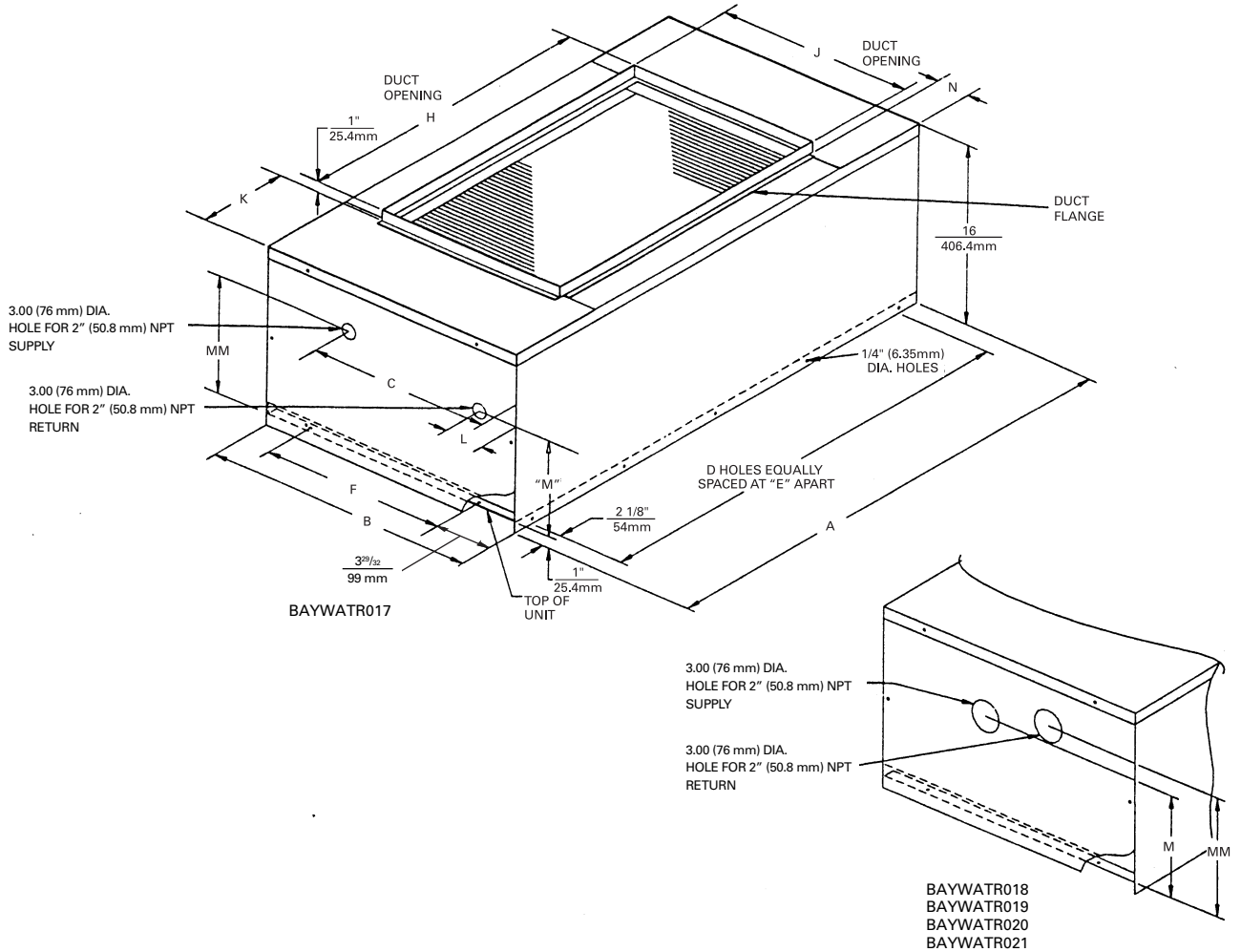

**Table DD-6 — Hot Water Coil Dimensions — in. (mm)**

Model	Accessory No.	A	B	C	D	E	F	G	H	J	K	L	N	M	MM
TWE050	BAYWATR017	38 (965)	22 <sup>3/32</sup> (561)	13 <sup>5/8</sup> (346)	5 (127)	9 (229)	14 <sup>1/32</sup> (356)	14 (356)	26 (660)	12 (305)	6 (152)	4 <sup>1/32</sup> (102)	2 <sup>27/32</sup> (72)	8 <sup>1/32</sup> (204)	10 <sup>9/16</sup> (268)
TWE075	BAYWATR018	47 <sup>19/32</sup> (1209)	25 <sup>5/32</sup> (639)	15 <sup>19/32</sup> (396)	5 (127)	10 <sup>27/32</sup> (275)	17 <sup>1/8</sup> (435)	14 (356)	30 (762)	18 (457)	8 <sup>27/32</sup> (225)	8 <sup>3/32</sup> (206)	2 <sup>27/32</sup> (72)	10 <sup>3/8</sup> (264)	7 <sup>7/8</sup> (200)
TWE100	BAYWATR019	63 <sup>19/32</sup> (1615)	25 <sup>5/32</sup> (639)	15 <sup>19/32</sup> (396)	6 (152)	11 <sup>7/8</sup> (302)	17 <sup>1/8</sup> (435)	16 (406)	36 (914)	18 (457)	13 <sup>27/32</sup> (352)	8 <sup>3/32</sup> (206)	2 <sup>27/32</sup> (72)	10 <sup>3/8</sup> (264)	7 <sup>7/8</sup> (200)
TWE155	BAYWATR020	79 <sup>21/32</sup> (2023)	27 <sup>25/32</sup> (706)	14 <sup>7/16</sup> (367)	6 (152)	15 <sup>3/32</sup> (383)	19 <sup>3/4</sup> (502)	16 (406)	51 (1295)	18 (457)	14 <sup>7/32</sup> (361)	6 <sup>15/16</sup> (176)	1 <sup>7/8</sup> (48)	9 <sup>9/16</sup> (243)	7 <sup>1/16</sup> (179)
TWE200	BAYWATR021	92 <sup>21/32</sup> (2353)	30 <sup>19/32</sup> (777)	16 <sup>3/8</sup> (416)	7 (178)	14 <sup>23/32</sup> (374)	22 <sup>9/16</sup> (573)	18 (457)	64 (1626)	18 (457)	14 <sup>7/32</sup> (361)	8 <sup>7/8</sup> (225)	3 <sup>3/4</sup> (95)	9 <sup>9/16</sup> (243)	7 <sup>1/16</sup> (179)

# Dimensional Data

**Figure DD-21 — Steam Coil**

All dimensions are in inches and millimeters.

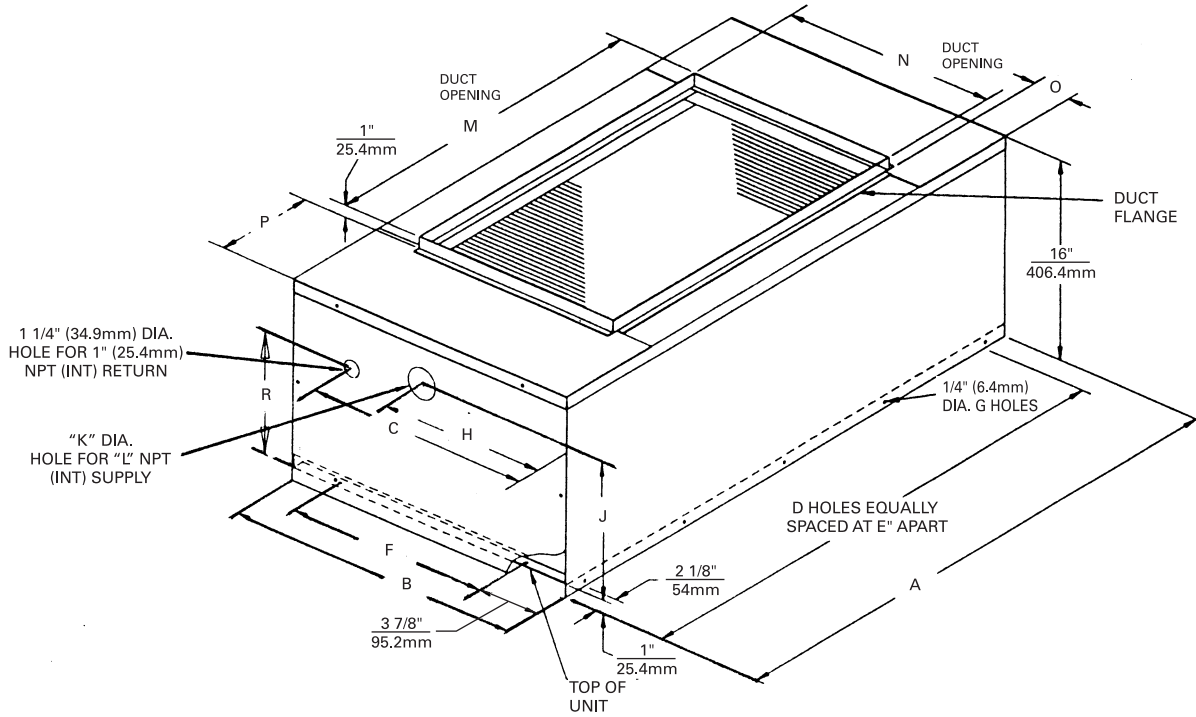

**Table DD-7 — Steam Coil Dimensions — in. (mm)**

Model	Accessory No.	A	B	C	D	E	F	G	H	J	K	L	M	N	P	Q	R
TWE050	BAYWATR012	38 (965.2)	22 <sup>1</sup> / <sub>8</sub> (562)	13 <sup>3</sup> / <sub>16</sub> (335)	5 (127)	9 (228.6)	14 <sup>1</sup> / <sub>16</sub> (357.2)	14 (355.6)	10 <sup>3</sup> / <sub>8</sub> (263.5)	11 <sup>3</sup> / <sub>8</sub> (288.9)	2 (50.8)	1 <sup>1</sup> / <sub>2</sub> (38.1)	26 (660.4)	12 (304.8)	6 (152.4)	2 <sup>1</sup> / <sub>8</sub> (73)	9 <sup>3</sup> / <sub>4</sub> (247.7)
TWE075	BAYWATR013	47 <sup>5</sup> / <sub>8</sub> (1209.7)	25 <sup>3</sup> / <sub>16</sub> (639.8)	19 <sup>13</sup> / <sub>16</sub> (503.2)	5 (127)	10 <sup>7</sup> / <sub>8</sub> (276.2)	17 <sup>1</sup> / <sub>8</sub> (435)	14 (355.6)	13 <sup>3</sup> / <sub>8</sub> (339.7)	11 <sup>3</sup> / <sub>8</sub> (288.9)	2 <sup>1</sup> / <sub>2</sub> (63.5)	2 (50.8)	30 (762)	18 (457.2)	8 <sup>7</sup> / <sub>8</sub> (225.4)	2 <sup>7</sup> / <sub>8</sub> (73)	9 <sup>3</sup> / <sub>4</sub> (247.7)
TWE100	BAYWATR014	63 <sup>5</sup> / <sub>8</sub> (1616.1)	25 <sup>3</sup> / <sub>16</sub> (639.8)	19 <sup>13</sup> / <sub>16</sub> (503.2)	6 (152.4)	11 <sup>7</sup> / <sub>8</sub> (301.6)	17 <sup>1</sup> / <sub>8</sub> (435)	16 (406.4)	13 <sup>3</sup> / <sub>8</sub> (339.7)	11 <sup>3</sup> / <sub>8</sub> (282.6)	2 <sup>1</sup> / <sub>2</sub> (63.5)	2 (50.8)	36 (914.4)	18 (457.2)	13 <sup>3</sup> / <sub>8</sub> (339.7)	2 <sup>7</sup> / <sub>8</sub> (73)	9 <sup>3</sup> / <sub>4</sub> (247.7)
TWE155	BAYWATR015	79 <sup>5</sup> / <sub>8</sub> (2022.5)	27 <sup>13</sup> / <sub>16</sub> (706.4)	24 <sup>15</sup> / <sub>16</sub> (633.4)	6 (152.4)	15 <sup>1</sup> / <sub>16</sub> (382.6)	19 <sup>3</sup> / <sub>4</sub> (501.7)	16 (406.4)	18 <sup>1</sup> / <sub>2</sub> (469.9)	11 <sup>3</sup> / <sub>8</sub> (282.6)	2 <sup>1</sup> / <sub>2</sub> (63.5)	2 (50.8)	51 (1295.4)	18 (457.2)	14 <sup>3</sup> / <sub>16</sub> (360.4)	1 <sup>7</sup> / <sub>8</sub> (476)	9 <sup>3</sup> / <sub>4</sub> (247.7)
TWE200	BAYWATR016	92 <sup>5</sup> / <sub>8</sub> (2352.7)	30 <sup>0</sup> / <sub>8</sub> (777.9)	25 <sup>7</sup> / <sub>8</sub> (657.2)	7 (177.8)	14 <sup>3</sup> / <sub>4</sub> (374.7)	22 <sup>9</sup> / <sub>16</sub> (573.1)	18 (457.2)	19 <sup>1</sup> / <sub>2</sub> (495.3)	12 <sup>1</sup> / <sub>6</sub> (309)	2 <sup>1</sup> / <sub>2</sub> (63.5)	2 (50.8)	64 (1625.6)	18 (457.2)	14 <sup>3</sup> / <sub>16</sub> (360.4)	3 <sup>3</sup> / <sub>4</sub> (95.3)	10 <sup>7</sup> / <sub>8</sub> (276.2)



# Weights

**Table W-1 – Unit and Corner Weights – lb (kg)**

Unit Model No.	Shipping Maximum – lb (kg)	Net Maximum – lb (kg)	Corner Weights			
			1	2	3	4
TTA075A	366 (166.0)	322 (146.1)	105 (47.6)	80 (36.3)	59 (26.8)	78 (35.4)
TTA100A	444 (201.4)	390 (176.9)	134 (60.8)	95.5 (43.3)	66.5 (30.2)	94 (42.6)
TTA100B	514 (233.1)	460 (208.7)	153 (69.4)	145 (65.8)	79 (35.8)	83 (37.7)
TTA100C	483 (219.1)	428 (194.1)	139 (63.0)	125 (56.7)	78 (35.4)	86 (39.0)
TTA125B	542 (245.9)	488 (221.4)	153 (69.4)	156 (70.8)	90 (40.8)	89 (40.4)
TTA155B	744 (337.5)	668 (303.0)	192 (87.1)	192 (87.1)	142 (64.4)	142 (64.4)
TTA155C	745 (337.9)	660 (299.4)	216 (98.0)	211 (95.7)	115 (52.2)	118 (53.5)
TTA200B	915 (415.0)	830 (376.5)	240 (108.9)	232 (105.2)	176 (79.8)	182 (82.6)

**Table W-2 – Accessory Weights – Net lb (kg)**

Unit Model No.	RIS Isolators	Steel Spring Isolators	Anti Short Cycle Timer	Coil Guard	Thermostats	Low Ambient
TTA075A	2 (.9)	12 (5.4)	1 (.5)	8 (3.6)	1 (.5)	23 (10.4)
TTA100A	2 (.9)	12 (5.4)	1 (.5)	11 (5)	1 (.5)	23 (10.4)
TTA100B	2 (.9)	12 (5.4)	1 (.5)	20 (9.1)	1 (.5)	23 (10.4)
TTA125B	2 (.9)	12 (5.4)	1 (.5)	22 (10)	1 (.5)	23 (10.4)
TTA155D	2 (.9)	12 (5.4)	1 (.5)	34 (15.4)	1 (.5)	23 (10.4)
TTA155C	2 (.9)	12 (5.4)	1 (.5)	34 (15.4)	1 (.5)	23 (10.4)
TTA200B	2 (.9)	12 (5.4)	1 (.5)	34 (15.4)	1 (.5)	23 (10.4)

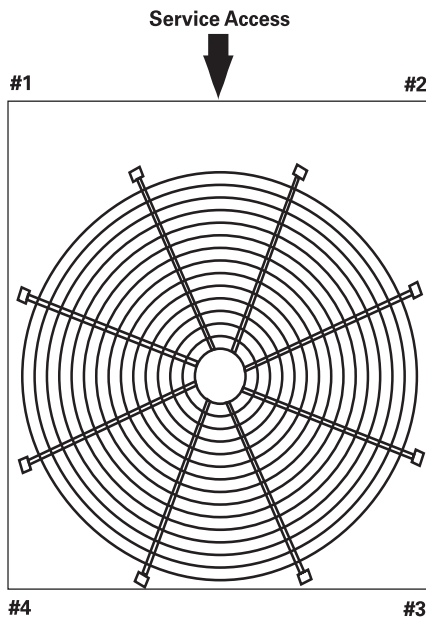

**TTA075, 100, 125**

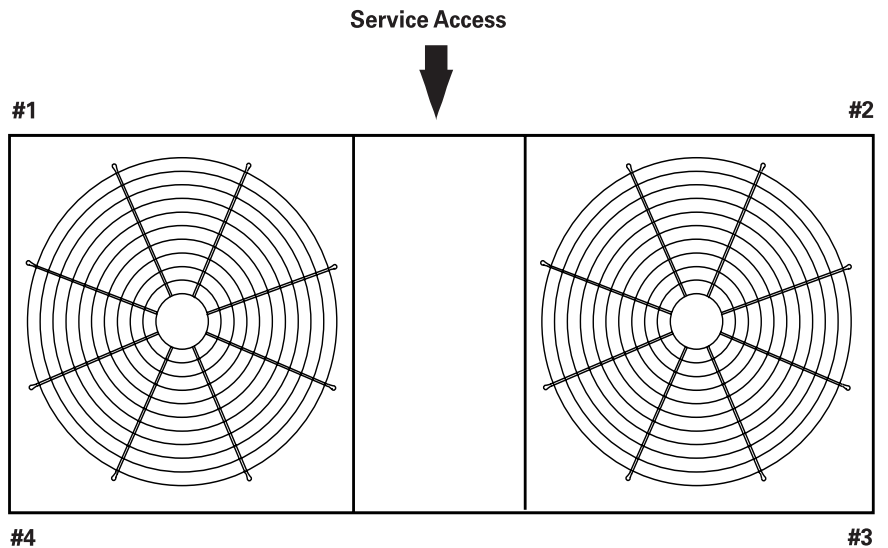

**TTA155, 200**

# Weights

**Table W-3 — Air Handlers, Coils, And Corner Weights — lb (kg)<sup>1</sup>**

Unit Model No.	Shipping Maximum (lb)	Net Maximum (lb)	Corner Weights — Vertical				Corner Weights — Horizontal			
			#1	#2	#3	#4	A	B	C	D
TWE050	298 (135)	262 (118.9)	59 (26.8)	59 (26.8)	59 (26.8)	59 (26.8)	54 (24.5)	64 (29)	64 (29.03)	54 (24.5)
TWE075	388 (176)	346 (157)	79 (35.9)	79 (35.9)	79 (35.9)	79 (35.9)	77 (35)	84 (38.1)	81 (36.7)	73 (33.1)
TWE100	473 (214.6)	419 (190.1)	107 (48.5)	107 (48.5)	107 (48.5)	107 (48.5)	102 (46.3)	113 (51.3)	113 (51.3)	102 (46.3)
TWE125	754 (342)	690 (313)	173 (78.5)	173 (78.5)	173 (78.5)	173 (78.5)	174 (79)	156 (70.8)	190 (86.2)	170 (77.1)
TWE200	886 (401.9)	820 (372)	204 (92.5)	204 (92.5)	204 (92.5)	204 (92.5)	185 (84)	228 (103.4)	221 (100.3)	179 (81.2)

Note:

1. If application requires steam or hot water heating coils, field supplied isolators must be utilized.

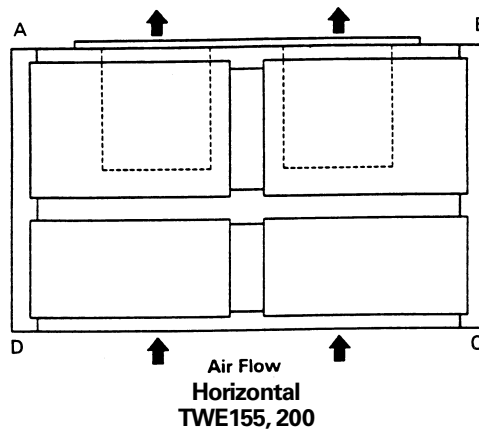
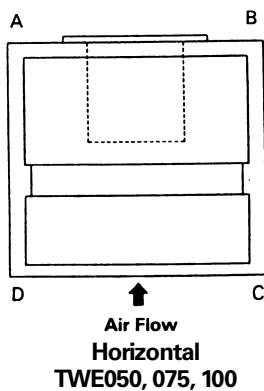
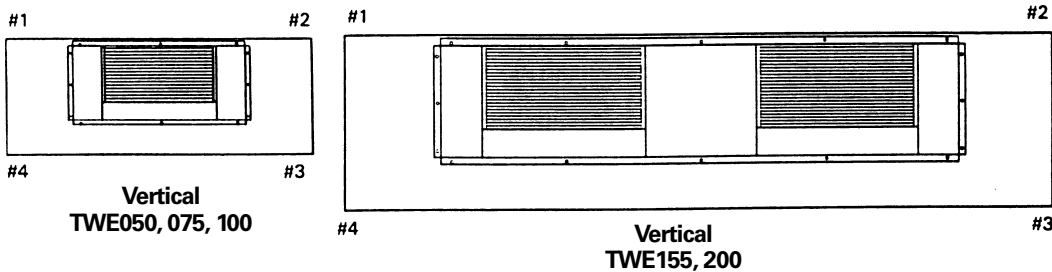

**Table W-4 — Accessory Weights (Net lb)**

Unit Model No.	Discharge Plenum And Grille <sup>1</sup>	Discharge Plenum And Grille <sup>2</sup>	Return Air Grille	Electric Heat Min. Max.	Subbase	Oversized Motor	RIS Isolator Floor Mount	RIS Isolator Suspended Mount	Steel Spring Isolator Floor Mount	Steel Spring Isolator Suspended Mount
TWE050	58 (26.3)	93 (42.2)	3 (1.4)	32/43 (14.5/19.5)	14 (6.4)	31 (14.1)	2 (.9)	9 (4)	12 (5.4)	6 (2.7)
TWE075	73 (33.1)	123 (55.8)	5 (2.3)	27/45 (12.3/20.4)	19 (8.6)	48 (21.8)	2 (.9)	6 (2.7)	12 (5.4)	6 (2.7)
TWE100	92 (41.7)	156 (70.8)	7 (3.2)	27/45 (12.3/20.4)	23 (10.4)	50 (22.7)	2 (.9)	7 (3.2)	12 (5.4)	6 (2.7)
TWE155	124 (56.3)	230 (104.3)	10 (4.5)	79/100 (35.8/45.4)	27 (12.3)	80 (36.3)	2 (.9)	7 (3.2)	12 (5.4)	6 (2.7)
TWE200	145 (65.8)	264 (119.8)	12 (5.4)	79/100 (35.8/45.4)	31 (14.06)	88 (40)	2 (.9)	9 (4)	12 (5.4)	6 (2.7)

Note:

1. For use when no heat is supplied.

2. For use with electric heat.

# Mechanical Specifications

## Condensing Units

### General

Units shall be assembled on heavy gauge steel mounting/lifting rails and shall be weatherproofed. Units shall include a hermetic scroll or reciprocating compressor(s), plate fin condenser coil, fans and motors, controls, and holding charge of nitrogen. Operating range shall be between 115°F (46.1°C) and 35°F (1.7°C) in cooling as standard from the factory. Units shall be rated in accordance with ARI Standard 210/240, 340/360 or 365.

### Casing

Unit casing shall be constructed of zinc coated, heavy gauge, galvanized steel. Exterior surfaces shall be cleaned, phosphatized, and finished with a weather-resistant baked enamel finish. Units surface shall be tested 500 hours in salt spray test. Units shall have removable end panels which allow access to all major components and controls.

### Refrigeration System – Single Compressor

TTA075A, TTA100A units shall have a single refrigeration circuit. Each refrigeration circuit has an integral subcooling circuit. A refrigeration filter drier shall be provided as standard. The units shall have both a liquid line and suction gas line service valve with gauge port. TTA075A, TTA100A units shall have one direct-drive, hermetic scroll compressor with centrifugal oil pump providing positive lubrication to moving parts. Motor shall be suction gas-cooled and shall have a voltage utilization range of plus or minus 10 percent of unit nameplate voltage. Crankcase heater, discharge line thermostat, and current-sensitive motor overloads shall be included for maximum protection. Scroll type compressor shall provide inherently low vibration and noise by having no suction and discharge valves. External high and low pressure cutout devices shall be provided. Evaporator defrost control provided in indoor blower coil shall prevent compressor slugging by temporarily interrupting compressor operation when low evaporator coil temperatures are encountered.

### Refrigeration System – Dual Compressor

TTA100B, TTA125B, TTA155B, TTA200B units shall have two separate and independent refrigeration circuits. Each refrigeration circuit shall have an integral subcooling circuit. A refrigeration filter drier shall be provided as standard. Units shall have both a liquid line and suction gas line service valve with gauge port.

TTA100B, TTA125B, units shall have two Trane direct-drive, hermetic reciprocating compressors with centrifugal oil pump and provide positive lubrication to all moving parts. Reciprocating compressor shall have internal spring isolation and sound muffling to minimize vibration transmission and noise.

TTA155B, TTA200B units shall have two Trane direct-drive, hermetic scroll compressors with centrifugal oil pump and provide positive lubrication to all moving parts. Motor shall be suction gas-cooled and shall have a voltage utilization range of plus or minus 10 percent of nameplate voltage. Crankcase heater, discharge line thermostat, and current-sensitive motor overloads shall be included for maximum protection. Scroll compressor shall provide inherently low vibration and noise by having no suction and discharge valves. External high and low pressure cutout devices shall be provided. Evaporator defrost control provided in indoor blower coil shall prevent compressor slugging by temporarily interrupting compressor operation when low evaporator coil temperatures are encountered.

### Refrigeration System – Dual Manifolder Compressors

TTA 100C and TTA155C units shall have a single refrigeration circuit with an integral subcooling circuit. A refrigeration filter drier shall be provided as standard. Units shall have both a liquid line and suction gas line service valve with gauge port. The units shall have two scroll compressors manifolded together. Motor shall be suction gas-cooled and shall have a voltage utilization range of plus or minus 10 percent of nameplate voltage. Crankcase heater, discharge line thermostat, and current-sensitive motor overloads shall be included for maximum protection. Scroll type compressor shall provide inherently low vibration and noise by having no suction and discharge valves. External high and low pressure cutout devices shall be provided. Evaporator defrost control provided in the indoor blower coil shall prevent compressor slugging by temporarily interrupting compressor operation when low evaporator coil temperatures are encountered.

### Condenser Coil

Coils shall be internally finned or smooth bore 3/8" (10 mm) copper tubes mechanically bonded to a configured aluminum plate fin as standard. Coil shall be factory pressure and leak tested to 420 psig (2,899 kPa) air pressure. Metal grilles with PVC coating for coil protection is optional.

### Condenser Fan And Motor(s)

Direct-drive, statically and dynamically balanced, 26 or 28-inch (660 or 711 mm) propeller fan(s) with aluminum blades and electro-coated steel hubs shall be used in draw-thru vertical discharge position. Either permanently lubricated totally enclosed or open construction motors shall be provided and shall have built-in current and thermal overload protection. Motor(s) shall have be either ball or sleeve bearing type.



# Mechanical Specifications

# Condensing Units

## Controls

Condensing units shall be completely factory wired with necessary controls and contactor pressure lugs or terminal block for power wiring. Control wiring shall be 24-volt control circuit which includes fusing and control transformer. Units shall provide external location for mounting a fused disconnect device. Time delay timers to prevent compressors in dual compressor units from simultaneous start-up and anti-recycle timers are available as optional accessories.

## Low Ambient Operation

Standard units shall start and operate to approximately 35°F (1.7°C) when matched with Trane air handlers and coils. Optional head pressure control accessory permits operation to 0°F (-17.8°C).

## Accessories

### Low Ambient Head Pressure Control

— This accessory shall modulate the RPM of unit outdoor fan motor in response to outdoor ambient temperature and unit head pressure. Accessory provides unit cooling operation to outdoor temperatures of 0° F (-17.8° C).

**Vibration Isolation Packages** — This accessory shall reduce transmission of noise and vibration to building structures, equipment, and adjacent spaces. Packages shall be available in either neoprene-in-shear or spring-flex types.

**Hot Gas Bypass Kit** — This accessory shall be available to provide capacity modulation.

**Time Delay Relay** — This accessory shall prevent compressors in dual compressor unit from combine on line simultaneously. Time shall be 24-volt, 60 cycle, with four minute timing period.

**Anti-Short-Cycle Timer** — This accessory shall prevent rapid on-off compressor cycling in light load conditions by not allowing compressor to operate for 5-7 minutes upon shutdown. This accessory shall consist of a 24-volt, solid state timing device with either 5 or 7 minute fixed-off timing period.

**Condenser Coil Guard** — Metal grille with PVC coating shall be provided to alleviate coil damage.

## Factory Installed Accessories

### Black Epoxy Coated Condenser Coil

— This option is designed to provide corrosion protection of air cooled condenser coils for seacoast application. The black epoxy coil protection is a factory applied thermoset vinyl coating, bonded to normal aluminum fin stock. The uniform thickness of the bonded vinyl layer exhibits excellent corrosion protection in salt spray tests performed in accordance with ASTM B177.

# Mechanical Specifications

## Air Handlers

### General

Air handler units shall be completely factory assembled including coil, condensate drain pan, fan motor(s), filters, and controls in an insulated casing that can be applied in either vertical or horizontal configuration. Units shall be rated and tested in accordance with ARI Standard 210, 240, 360.

### Casing

Unit casing shall be constructed of zinc coated, heavy gauge, galvanized steel. Exterior surfaces shall be cleaned, phosphatized, and finished with a weather-resistant baked enamel finish. Casing is completely insulated with fire-retardant, permanent, odorless, glass fiber material. Knockouts shall be provided for unit electrical power and refrigerant piping connections. Captive screws shall be standard on all access panels.

### Refrigeration System

The TWE050A, TWE075A, TWE100A units shall have a single refrigeration circuit and the TWE050B, TWE100B, TWE155B, TWE200B units shall have dual refrigeration circuits. Each refrigeration circuit is controlled by a factory installed thermal expansion valve.

### Evaporator Coil

Configured aluminum fin surface shall be mechanically bonded to  $\frac{3}{8}$ " (10 mm) internally enhanced copper tubing and factory pressure and leak tested at 375 psig (2,586 kPa). Coil is arranged for draw-thru airflow and shall provide condensate drain pan constructed of PVC plastic and provide external connections on either side of the unit.

### Evaporator Fan

Double inlet, double width, forward curved, centrifugal-type fan(s) with adjustable belt drive shall be standard. Thermal overload protection shall be standard on motor. Fan and motor bearings shall be permanently lubricated. Oversized motors shall be available as an option for high static application.

### Controls

Magnetic evaporator fan contactor, low voltage terminal strip, check valve(s), and single point power entry shall be included. All necessary controls shall be factory-installed and wired. Evaporator defrost control shall be included to prevent compressor slugging by temporarily interrupting compressor operation when low evaporator coil temperatures are encountered.

### Filters

One inch, throwaway filters shall be standard on TWE050A, TWE050B, TWE075A, TWE100A and TWE100B model air handlers. Filters shall be accessible from the side coil access panel. Filter rack can be field converted to two-inch capability. Two-inch throwaway filters shall be standard on TWE155B and TWE200B models.

### Accessories

**Electric Heaters** — Approved electric heat modules shall be available for installation directly on fan discharge. Electric heaters shall be available in a wide range of capacities with one or two-stage control, single-point electric power connection and terminal strip connections. Electric heater elements shall be constructed on heavy-duty nickel chromium elements internally wye connected on 480 volt, three phase. Each 480 volt heater shall have automatic line break high limit controls.

### Discharge Plenums and Grilles —

Accessory discharge plenums shall be available for vertical, free discharge applications. Plenums shall be constructed of heavy-gauge, zinc coated, galvanized steel finished with baked enamel to match the air handler unit. Grilles shall be satin finished aluminum and have four-way adjustable louvers.

### Return Air Grilles —

Accessory return air grille shall be provided for vertical front, free return applications. Grilles shall be installed in place of the front lower side panel. Grille shall be satin finished aluminum with non-adjustable louvers.

### Mounting Subbase —

This accessory shall be available for vertical floor mount configurations. Subbase shall be constructed of heavy gauge, zinc coated, galvanized steel with baked enamel finish to match air handler unit. Subbase is required in the vertical air flow application for condensate drain trapping and when isolators are required.

**Vibration Isolators** — This accessory shall reduce transmission of noise and vibration to building structures, equipment, and adjacent spaces. Packages shall be available in either neoprene-in shear or spring-flex types in floor or suspended mountings.

**Oversized Motors** — Field installed oversized motors shall be available for high static pressure applications.

### Control Options

**Standard Indoor Thermostats** — Two stage heating and cooling operation or one stage heating and cooling thermostats shall be available in either manual or automatic changeover.

**Programmable Electronic Night Setback Thermostat** — The option shall provide heating setback and cooling setup with 7-day programming capability.







**TRANE®**

**The Trane Company**  
**An American Standard Company**  
**[www.trane.com](http://www.trane.com)**

*For more information contact your  
local office or e-mail us at  
[comfort@trane.com](mailto:comfort@trane.com)*



Literature Order Number	SS-PRC003-EN
File No.	PLUN-SS-PRC003-EN-12-00
Supersedes	SS-PRC003-EN 07-00
Stocking Location	Inland - LaCrosse

Since The Trane Company has a policy of continuous product and product data improvement, it reserves the right to change design and specifications without notice.



## Free Manuals Download Website

<http://myh66.com>

<http://usermanuals.us>

<http://www.somanuals.com>

<http://www.4manuals.cc>

<http://www.manual-lib.com>

<http://www.404manual.com>

<http://www.luxmanual.com>

<http://aubethermostatmanual.com>

Golf course search by state

<http://golfingnear.com>

Email search by domain

<http://emailbydomain.com>

Auto manuals search

<http://auto.somanuals.com>

TV manuals search

<http://tv.somanuals.com>