



Split System Heat Pumps

Split System Heat Pumps
TWA075A-TWA200B
Air Handlers
TWE050A-TWE200B
50 Hz



October 2003

SSP-PRC002-EN



Introduction

Simply

THE BEST VALUESM



**Split System Heat Pumps...
Designed With Your Needs In Mind.**
The Trane reputation for quality and reliability is reflected in the Odyssey™ Commercial Split System Heat Pumps. Trane's focused attention on the split system marketplace results in an outstanding heat pump that meets job requirements...and at a very competitive price.

Efficiency, flexibility and installation ease, coupled with Trane's reputation for quality and reliability, gives you a system that is "Simply the Best Value".

Contents

Introduction	2
Features and Benefits	4
Application Considerations	6
Selection Procedure	7
Model Number Description	8
General Data	9
Performance Data	12
Cool and Heat Performance	12
Fan Performance	24
Electric Power	31
Connection and Wiring	33
Dimension and Weights	39
Mechanical Specifications	55



Features and Benefits

Heat Pumps

- 3-D® Scroll compressors
- Model TWA155-200B have dual compressors with independent refrigerant circuits
- Compressor motor overload protection
- Control transformer
- High and low pressure cut-out switches
- Liquid line filter drier, factory installed
- Holding charge of dry nitrogen
- Copper tube, aluminum plate fin coils
- Low ambient cooling to 35°F (1.7°C) as manufactured
- Weather resistant baked enamel finish
- Heavy gauge steel cabinet
- Mounting/lifting rails under base

All condensing units offer these optional accessories:

- Head Pressure Control — Low Ambient Cooling To 0°F (-17.8°C)
- Coil Guards Kits
- Isolators both Rubber-in-Shear and Spring Type
- Anti-Short-Cycle Kit
- Time Delay Relay

Air Handlers

- Low voltage terminal board
- Expansion valve(s)
- Convertible
- PVC double-sloped, removeable drain pan
- Fan relay
- Efficient evaporator coil
- Baked enamel finish
- Filter access panel
- 1" (25.4 mm) throwaway filters standard with provisions for field supplied 2" (50.8 mm) filters
- Adjustable belt drive motor
- Single point power entry to electric heaters
- Refrigerant piping and/or electrical connections provided from either side

Odyssey™ air handler versatility is further increased by a complete line of optional accessories designed to match and easy to install:

- Discharge Plenum and Grille
- Return Grille
- Subbase
- Electric Heaters
- High Static Evaporator Motor
- Isolators both Rubber-in-Shear and Spring Type

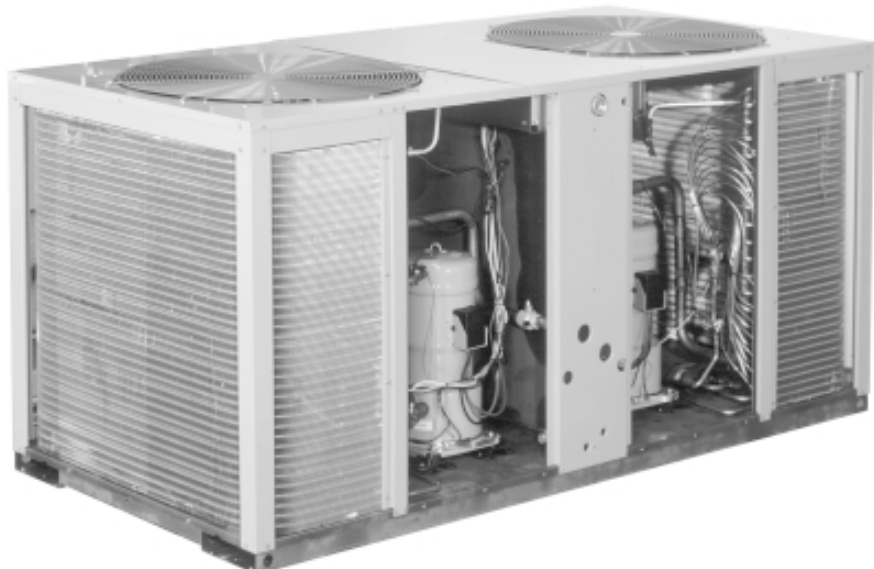

Features and Benefits

Heat Pump Options

The Odyssey™ split system product line includes heat pumps in both single and dual compressor options.

TWA075A and TWA100A single compressor models feature single refrigeration circuitry lowering job installation costs by requiring only one set of refrigerant lines. These units are ideal for low cost, new construction jobs as well as renovation and replacement buildings.

In addition, Odyssey models TWA155B through TWA200B are dual compressor units that give true standby protection; if one compressor fails, the second will automatically start-up. Also, the first compressor can be serviced without shutting down the unit since refrigerant circuits are independent.

Dual compressors are not just for protection, they also save energy costs. Most buildings are designed for the peak load requirements yet the building usually operates at less than peak load. During light load conditions only one compressor functions to maintain the space comfort thus reducing the need for energy.

Low Ambient Cooling Operation

Each condensing unit can operate to 35°F (1.7°C) as standard. An accessory Head Pressure Control gives you the capability to operate to 0°F (-17.8°C). All condensing units offer these accessories:

- Head Pressure Control
- Coil Guard Kits
- Isolators both Rubber-in-Shear and Spring Type
- Anti-Short-Cycle Kit
- Time Delay Relay

Trane split systems have been specified in thousands of applications and you'll find Odyssey will win you even more jobs with it's smaller, more manageable cabinet.

Air Handlers Offer More Flexibility

Flexibility is a key to meeting changing market requirements. Odyssey split systems offer various compressor options and convertible air handlers. The air handlers can be installed either vertically in a mechanical room or horizontally above a ceiling. And it doesn't require any removal of panels or reconfiguration of the drain pan to make either airflow application work. All the air handlers feature factory installed belt drive and ball bearing evaporator fans with adjustable sheaves for maximum airflow performance. The standard motor on the TWE100A air handler will deliver 3325 cfm (5650 m³/h) at 0.8" (200 Pa) ESP. Plus oversized motors are available for higher static applications.

Odyssey air handler versatility is further increased by a complete line of accessories designed to match and install smoothly:

- Discharge Plenum and Grille
- Return Grille
- Subbase
- Electric Heaters
- High Static Evaporator Motor
- Isolators both Rubber-in-Shear and Spring Type
- A Full Line of Thermostats

Odyssey™ — A Complete Split System

Odyssey delivers the flexibility to select a complete system that meets your particular job requirements. Air Handlers are designed, tested and rated with condensing units to let you select the proper match between capacity and load. Condensing units can also be matched with Trane built-up air handlers. These matched systems can be quickly engineered for specific applications.



Application Considerations

Application of this product should be within the catalogued airflow and performance considerations.

Clearance Requirements

The recommended clearances identified with unit dimensions should be maintained to assure adequate serviceability, maximum capacity and peak operating efficiency. Actual clearances that appear inadequate should be reviewed with the local Trane Representative.

Low Ambient Cooling

As manufactured, these units can operate to 35°F (1.7°C) in the cooling mode of operation. An accessory head pressure control will allow operation to 0°F (-17.8°C) outdoor ambient. When using these units with control systems such as bypass changeover Variable Air Volume, consider the requirement for a head pressure control to allow low ambient cooling.

Typical Horizontal Air Handler Application

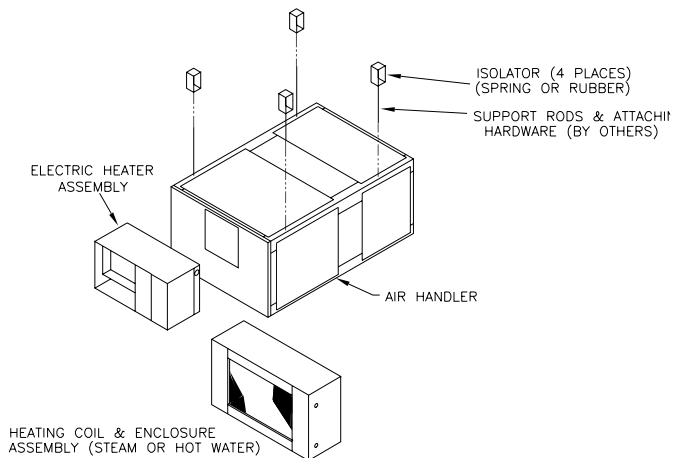

Typical Vertical Air Handler Application

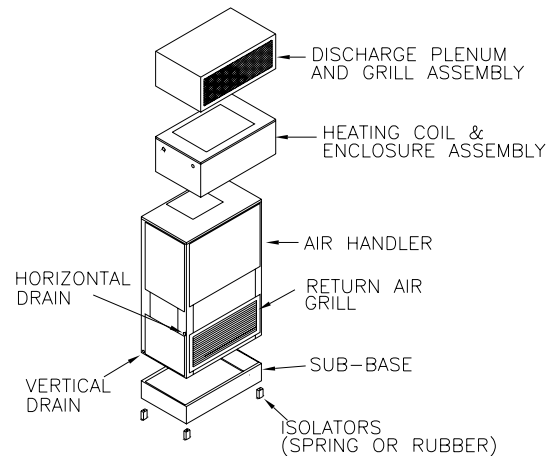

Typical Split System Application

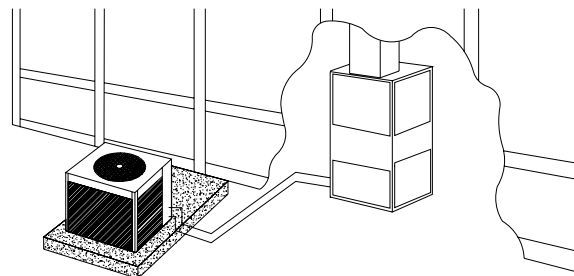

Selection Procedure

Cooling Capacity

Step 1 — Calculate the building's total and sensible cooling loads at design conditions. Use the Trane calculation form or any other standard accepted method.

Step 2 — Size the equipment using Table PD-1. Match the cooling loads at design conditions.

Example: The following are the building cooling requirements

- a Electrical Characteristics: 380-415/50/3
- b Summer Design Conditions: Entering Evaporator Coil: 80 DB/67 WB (27 DB/19 WB°C)
- c Outdoor Ambient: 95°F (35° C)

- d Total Cooling Load: 75 MBh (22kW)
- e Sensible Cooling Load: 53 MBh (15.5 kW)

- f Airflow: 2500 cfm (4247 m³/h)
- g External Static Pressure: 0.77 in. wg (193 Pa)

Table PD-1 shows that a TWA075A matched with a TWE075A has a gross cooling capacity of 82.4 MBh (24.1 kW) and 59.5 MBh (17.4 kW) sensible capacity at 95 DB (35°C) ambient and 2500 cfm (4247 m³/h) and 80 DB/67 WB (27 DB/19 WB) air entering the evaporator.

To find the net cooling capacities, fan motor heat must be subtracted. Determine the total unit static pressure:

External Static	0.77 in (193 Pa)
Standard Filter	0.10 in (25 Pa)
Supplementary Electric Heat	0.23 in (57 Pa)
Total Static Pressure	1.10 in (275 Pa)

Note: The Evaporator Fan Performance Table has included the effect of a 1 in. (250 Pa) filter already. Therefore, the actual Total Static Pressure is 1.10 - 0.10 = 1.00 in. (275 - 25 = 250 Pa).

With 2500 cfm (4247 m³/h) and 1.00 inches (250 Pa), Table 26-1 shows a 1.07 bhp (0.8 kW).

Note: The formula below the table can be used to calculate Fan Motor Heat, Constant x Motor Power = Fan Motor Heat

$$3.5 \times \text{bhp} = \text{MBh}$$

$$3.5 \times 1.07 = 3.75 \text{ MBh}$$

$$1.375 \times (\text{kW}) = \text{kW}$$

$$1.375 \times 0.8 = 1.1 \text{ kW}$$

$$\text{Net Total Cooling Capacity} = 79.6 \text{ MBh} - 3.75 = 75.85 \text{ MBh}$$

$$= 23.3 \text{ kW} - 1.1 = 22.2 \text{ kW}$$

$$\text{Net Sensible Cooling Capacity} = 57.1 \text{ MBh} - 3.75 = 53.35 \text{ MBh}$$

$$= 16.7 \text{ MBh} - 1.1 = 15.6 \text{ kW}$$

Heating Capacity

Step 1 — Calculate the building heating load using the Trane calculation form or any other standard accepted method.

Step 2 — Size the equipment using Table PD-9 to match the heating loads at design conditions. The following are building heating requirements:

- a Total Heating Load: 110 MBh (32.2 kW)
- b Outdoor Ambient (Winter): 17°F (-8.3°C) DB
- c Indoor Return Temperature: 70°F (21.1°C) DB
- d Airflow: 2500 cfm (4247 m³/h)

Table PD-9 indicates the mechanical heating portion of the heat pump will provide 37.5 MBh (11.0 kW) for the winter design conditions.

Step 3 — Because 37.5 MBh (11.0 kW) is less than the building's required heating capacity, a supplementary heater must be selected. 110 - 37.5 = 72.5 MBh (32.2 - 11.0 = 21.2 kW) minimum heater capacity.

From Table PD-25, the 24.22 kW heater has a capacity of 82,670 Btu. From Table 34-1, the 24.22 kW heater at 400V indicates the heater model number is BAYHTRL435A. This heater will be adequate to cover the residual heat capacity needed for the application.

Air Delivery Selection

External static pressure drop through the air distribution system has been calculated to be 0.77 inches (192.5 Pa) of water gauge. From Table PD-24 static pressure drop through the electric heater is 0.12 inches (30 Pa) of water (0.77 + 0.12 = .89 in.) (192.5 + 30 = 222.5 Pa). Enter Table PD-15 for TWE090A4 at 2500 cfm (4247 m³/h) and .90 in. (225 Pa) static pressure. The standard motor at 790 rpm will give the desired airflow.



Model Number Description

Split System Heat Pump Model Nomenclature

T	W	A	0	7	5	A	D	0	0	D	A
1	2	3	4	5	6	7	8	9	10	11	12

Digits 1, 2, 3 - Product Type

TWA = Split System Heat Pump

Digits 4, 5, 6 - Nominal Gross Cooling Capacity (MBh)

075 = 75
 100 = 100
 155 = 155
 200 = 200

Digit 7 - Major Development Sequence

A = Single Compressor
 B = Dual Compressor

Digit 8 - Electrical Characteristics

D = 380-415/3/50

Digits 9, 10 - Factory - Installed Options

00 = No Options
 OS = Black Epoxy Coated Coil

Digit 11 - Minor Design Sequence

D = Fourth

Digit 12 - Service Digit

A = First

Air Handler Model Nomenclature

T	W	E	0	5	0	A	D	0	0	C	A
1	2	3	4	5	6	7	8	9	10	11	12

Digits 1, 2, 3 - Product Type

TWE = Cooling Convertible

Digits 4, 5, 6 - Nominal Gross Cooling Capacity (MBh)

050 = 50
 075 = 75
 100 = 100
 155 = 155
 200 = 200

Digit 7 - Refrigerant Circuit

A = Single
 B = Dual

Digit 8 - Electrical Characteristics

D = 380-415/3/50

Digit 9, 10 - Factory - Installed Options

00 = No Options

Digit 11 - Minor Design Sequence

C = Third

Digit 12 - Service Digit

A = First



General Data

(Heat Pumps)

Table GD-1 — General Data — Heat Pumps

	TWA075A	TWA100A
Cooling Performance¹		
Gross Cooling Capacity, Btu (kW)		
Matched Air Handler, Btu (kW)	82,000 (23.97)	109,000 (31.97)
Heat Pump Only ² , Btu (kW)	82,000 (23.97)	105,000 (30.75)
ARI Net Cooling Capacity ³	80,000 (23.35)	105,000 (30.75)
System Power kW	7.36	10.32
Heat Pump Only Power kW	6.61	9.22
Heating Performance		
ARI Heating with Matched Air Handler		
High Temperature Capacity, Btu (kW)	75,000 (21.82)	106,000 (31.05)
Low Temperature Capacity, Btu (kW)	47,000 (13.84)	69,000 (20.29)
Compressor		
Number	1	1
Type	3D [®] Scroll	3D [®] Scroll
No. Speeds	1	1
No. Motors	1	1
Motor HP (kW)	6.25 (4.7)	8.33 (6.21)
Motor RPM	2875	2875
ARI Sound Rating (Bels) ⁴	8.8	8.8
System Data⁵		
No. Refrigerant Circuits	1	1
Suction Line, in. (mm) OD	1.375 (34.9)	1.375 (34.9)
Liquid Line, in. (mm) OD	0.500 (12.7)	0.500 (12.7)
Outdoor Coil — Type		
Tube Size, in. (mm) OD	0.375 (9.5)	0.375 (9.5)
Face Area, sq. ft (m ²)	19.2 (1.78)	24.0 (2.23)
Rows	2	2
Fins Per Inch (Fins per mm)	18 (457)	18 (457)
Outdoor Fan Type		
Propeller		
No. Used	1	1
Diameter, in. (mm)	26.00 (660.4)	28.00 (711)
Drive Type	Direct	Direct
No. Speeds	1	1
CFM ⁶ , (m ³ /h)	4700 (7985)	6700 (11382)
No. Motors	1	1
Motor HP (kW)	0.33 (.24)	0.75 (.56)
Motor RPM	925	925
R-22 Refrigerant Charge, lb ⁷ (kg)	18.0 (8.16)	24.25 (11.0)

Notes:

- Cooling Performance is rated at 95°F (35°C) ambient, 80°F (26.7°C) entering dry bulb, 67°F (19.4°C) entering wet bulb and nominal cfm listed. ARI rating cfm is 350 cfm/ton for this product. Gross capacity does not include the effect of fan motor heat. ARI capacity is net and includes the effect of fan motor heat. Units are suitable for operation to ±20% of nominal cfm. Rated accordance with ARI Standard 210.
- Condensing Unit Only Gross Cooling Capacity rated at 45°F (7.2°C) saturated suction temperature and at 95°F (35°C) ambient.
- ARI Net Cooling Capacity is calculated with matched blower coil and 25 ft (7.2 m) of 1.375, 0.500 OD interconnecting tubing. EER and/or SEER are rated at ARI conditions and in accordance with DOE test procedures. Integrated Part Load Value is based on ARI Standard 210/240/340. Units are rated at 80°F (26.7°C) ambient, 80°F (26.7°C) entering dry bulb, and 67°F (19.4°C) entering wet bulb at ARI rated cfm.
- ARI Sound Rating is rated in accordance with ARI Standard 270.
- System Data based on maximum linear length 80 ft (26.7 m). Maximum lift: suction 60 ft (18.3 m) liquid 60 ft (18.3 m). For greater lengths, refer to refrigerant piping applications manual.
- Outdoor Fan cfm is rated with standard air-dry coil outdoor.
- Refrigerant (operating) charge is for condensing unit (all circuits) with matching blower coils and 25 ft (7.6 m) of interconnecting refrigerant lines.



General Data

(Heat Pumps)

Table GD-2 General Data — Heat Pumps

	TWA155B	TWA200B
Cooling Performance¹		
Gross Cooling Capacity, Btu (kW)		
Matched Air Handler, Btu (kW)	166,000 (48.57)	216,000 (63.24)
Condensing Unit Only ² , Btu (kW)	161,000 (47.04)	209,000 (61.18)
ARI Net Cooling Capacity ³	160,000 (46.74)	196,000 (61.18)
System Power kW	14.98	20.61
Condensing Unit Power kW	13.20	18.52
Heating Performance		
ARI Heating with Matched Air Handler		
High Temperature Capacity, Btu (kW)	151,000 (44.27)	206,000 (60.26)
Low Temperature Capacity, Btu (kW)	95,000 (27.67)	135,000 (39.66)
Compressor		
Number	2	2
Type	3D [®] Scroll	3D [®] Scroll
No. Speeds	1	1
No. Motors	2	2
Motor HP	6.25 (4.7)	8.33 (6.21)
Motor RPM, (kW)	2875	2875
ARI Sound Rating (Bels) ⁴	8.8	8.8
System Data⁵		
No. Refrigerant Circuits	2	2
Suction Line, in. (mm) OD	1.375 (34.9)	1.375 (34.9)
Liquid Line, in. (mm) OD	0.500 (12.7)	0.500 (12.7)
Outdoor Coil — Type		
Tube Size, in. (mm) OD	Plate Fin	Plate Fin
Face Area, sq. ft (m ²)	0.375 (9.5)	0.375 (9.5)
Rows	38.4 (3.57)	48.0 (4.46)
Fins Per Inch(mm)	2	2
	18 (457)	18 (457)
Outdoor Fan Type		
Propeller/Propeller	Propeller/Propeller	Propeller/Propeller
No. Used	2	2
Diameter, in. (mm)	26.00/26.00 (660.4/660.4)	28.00/28.00 (711/711)
Drive Type	Direct/Direct	Direct/Direct
No. Speeds	1	1
CFM ⁶ , (m ³ /h)	9800 (16649)	13400 (22764)
No. Motors	2	2
Motor HP (kW)	0.33 (.24)	0.75 (.56)
Motor RPM	925	925
R-22 Refrigerant Charge, lb ⁷ (kg)	36.0 (16.32)	48.5 (22.0)

Notes:

- Cooling Performance is rated at 95°F (35°C) ambient, 80°F (26.7°C) entering dry bulb, 67°F (19.4°C) entering wet bulb and nominal cfm listed. ARI rating cfm is 350 cfm/ton for this product. Gross capacity does not include the effect of fan motor heat. ARI capacity is net and includes the effect of fan motor heat. Units are suitable for operation to ±20% of nominal cfm. Rated accordance with ARI Standard 210.
- Condensing Unit Only Gross Cooling Capacity rated at 45°F (7.6°C) saturated suction temperature and at 95°F (35°C) ambient.
- ARI Net Cooling Capacity is calculated with matched blower coil and 25 ft (7.6 m) of 1.375, 0.500 OD interconnecting tubing. EER and/or SEER are rated at ARI conditions and in accordance with DOE test procedures. Integrated Part Load Value is based on ARI Standard 210/240/340. Units are rated at 80°F (26.7°C) ambient, 80°F (26.7°C) entering dry bulb, and 67°F (19.4°C) entering wet bulb at ARI rated cfm.
- ARI Sound Rating is rated in accordance with ARI Standard 270.
- System Data based on maximum linear length 80 ft (26.7 m) Maximum lift: suction 60 ft (18.3 m) liquid 60 ft (18.3 m) For greater lengths, refer to refrigerant piping applications manual.
- Outdoor Fan cfm is rated with standard air-dry coil outdoor.
- Refrigerant (operating) charge is for condensing unit (all circuits) with matching blower coils and 25 ft (7.6 m) of interconnecting refrigerant lines.



General Data

(Air Handlers)

Table GD-3 — General Data — Air Handlers

	TWE050A	TWE075A	TWE100A	TWE100B
System Data¹				
No. Refrigerant Circuits	1	1	1	2
Suction Line, in. (mm) OD	1.120 (28.4)	1.380 (35.0)	1.380 (35.0)	1.380 (35.0)
Liquid Line, in. (mm) OD	0.38 (9.7)	0.50 (12.7)	0.50 (12.7)	0.50 (12.7)
Indoor Coil — Type	Plate Fin	Plate Fin	Plate Fin	Plate Fin
Tube Size, in. (mm) OD	0.375 (9.5)	0.375 (9.5)	0.375 (9.5)	0.375 (9.5)
Face Area, sq. ft (m ²)	5.00 (.47)	8.07 (.75)	11.18 (1.0)	11.18 (1.0)
Rows	3	3	3	3
Fins Per Inch	12	12	12	12
Refrigerant Control	Expansion Valve	Expansion Valve	Expansion Valve	Expansion Valve
Drain Connection No.	4	4	4	4
Drain Connection Size, in. (mm)	0.75 (19.0)	0.75 (19.0)	0.75 (19.0)	0.75 (19.0)
Drain Connection Type	PVC	PVC	PVC	PVC
Indoor Fan Type	FC Centrifugal	FC Centrifugal	FC Centrifugal	FC Centrifugal
No. Used	1	1	1	1
Diameter, in. (mm)	12.0 (304.8)	15.0 (381)	15.0 (381)	15.0 (381)
Width, in. (mm)	12.0 (304.8)	15.0 (381)	15.0 (381)	15.0 (381)
Drive Type	Belt	Belt	Belt	Belt
No. Speeds	1	1	1	1
CFM, (m ³ /h)	1670 (2837)	2500 (4247)	3325 (5649)	3325 (5649)
No. Motors	1	1	1	1
Motor HP (kW)				
— Standard/Oversized	0.75/1.0 (.55/.74)	1.0/1.5 (.74/1.11)	1.5/2.0 (1.11/1.49)	1.5/2.0 (1.11/1.49)
Motor RPM (Standard)	1425	1425	1425	1425
Motor Frame Size (Standard)	56	56	56	56
Filters — Type	Throwaway	Throwaway	Throwaway	Throwaway
Furnished	Yes	Yes	Yes	Yes
No.	1/1	3	4	4
Recommended Size, in. (mm)	16x20x1/20x20x1 406.4x508x25.4 4/508x508x25.4	16x25x1 406.4/635/25.4	16x25x1 406.4/635/25.4	16x25x1 406.4/635/25.4

Table GD-3 — General Data — Continued

	TWE155B	TWE200B
System Data		
No. Refrigerant Circuits	2	2
Suction Line, in. (mm) OD	1.38 (35.0)	1.38 (35.0)
Liquid Line, in. (mm) OD	0.500 (12.7)	0.500 (12.7)
Indoor Coil — Type	Plate Fin	Plate Fin
Tube Size, in. (mm) OD	0.375 (9.5)	0.375 (9.5)
Face Area, sq. ft (m ²)	16.33 (1.52)	21.63 (2.01)
Rows	3	3
Fins Per Inch	12	12
Refrigerant Control	Expansion Valve	Expansion Valve
Drain Connection No.	4	4
Drain Connection Size, in. (mm)	1.000 (25.4)	1.000 (25.4)
Drain Connection Type	PVC	PVC
Indoor Fan Type	FC Centrifugal	FC Centrifugal
No. Used	2	2
Diameter, in. (mm)	15.0 (381)	15.0 (381)
Width, in. (mm)	15.0 (381)	15.0 (381)
Drive Type	Belt	Belt
No. Speeds	1	1
CFM, (m ³ /h)	5000 (8494)	6650 (11297)
No. Motors	1	1
Motor HP (kW)		
— Standard/Oversized	2.0/3.0 (1.49/2.24)	3.0/5.0 (2.24/3.72)
Motor RPM (Standard)	1425	1425
Motor Frame Size (Standard)	145T	184T
Filters — Type	Throwaway	Throwaway
Furnished	Yes	Yes
No.	8	4/4
Recommended Size, in. (mm)	15x20x2 381x508x50.8	16x20x2/16x25x2 406.4x508x50.8/406.4x635x50.8

Notes:

1. ARI certified with various condensing units per ARI Standard 210. Refer to Performance Data section in this catalog.



Performance Data (System)

Table PD-1 — Gross Cooling Capacities (MBh) TWA075A Heat Pump with TWE075A Air Handler (I-P)

CFM	Enter. Dry Bulb (°F)	Ambient Temperature (°F)																							
		85			95				105			115													
		61		67	61		67		73		61		67		73										
		Total	Sens.	Total	Sens.	Total	Sens.	Total	Sens.	Total	Sens.	Total	Sens.	Total	Sens.	Total	Sens.	Total	Sens.						
2250	75	75.7	60.5	83.8	50.3	92.4	34.1	73.2	59.2	80.9	49.1	89.1	32.9	70.2	57.7	77.5	47.8	85.3	31.6	66.7	56.0	73.6	46.2	81.1	30.2
	80	76.2	70.8	84.0	58.2	92.4	44.8	73.7	69.5	81.1	57.0	89.1	43.6	70.8	68.1	77.6	55.4	85.4	42.2	67.5	66.4	73.8	53.8	81.2	40.7
	85	78.3	78.3	84.1	68.4	92.5	55.4	76.1	76.1	81.2	67.1	89.3	54.2	73.6	73.6	77.8	65.6	85.5	52.8	70.6	70.6	74.0	63.9	81.4	51.3
	90	82.3	82.3	84.6	78.7	92.7	65.9	80.0	80.0	81.8	77.5	89.4	64.5	77.4	77.4	78.6	76.0	85.6	63.0	74.3	74.3	75.0	74.4	81.5	61.4
2500	75	77.2	63.4	85.3	49.5	93.9	34.7	74.6	62.1	82.3	48.2	90.5	33.6	71.4	60.5	78.8	46.8	86.6	32.2	67.8	58.8	74.8	45.2	82.2	30.6
	80	77.9	74.7	85.5	61.0	93.9	46.4	75.4	73.4	82.4	59.5	90.5	45.1	72.4	72.0	78.9	58.0	86.7	43.7	68.9	68.9	75.0	56.3	82.4	42.2
	85	80.9	80.9	85.6	72.0	94.1	57.9	78.6	78.6	82.6	70.7	90.7	56.7	75.9	75.9	79.2	69.2	86.8	55.3	72.8	72.8	75.3	67.5	82.6	53.7
	90	85.0	85.0	86.4	83.4	94.1	69.1	82.7	82.7	83.6	82.1	90.8	67.8	79.8	79.8	79.9	79.9	87.0	66.3	76.6	76.6	76.7	76.7	82.7	64.7
2750	75	78.5	66.1	86.5	51.2	95.1	35.3	75.7	64.8	83.4	49.9	91.6	34.1	72.5	63.2	79.8	48.4	87.6	32.7	68.9	61.5	75.8	46.8	83.1	31.1
	80	79.4	78.5	86.6	63.4	95.2	47.8	76.5	76.5	83.6	62.0	91.7	46.6	73.8	73.8	80.0	60.5	87.7	45.2	70.7	70.7	75.9	58.8	83.3	43.6
	85	83.1	83.1	86.9	75.4	95.3	60.3	80.7	80.7	83.9	74.1	91.8	59.0	77.9	77.9	80.4	72.6	87.9	57.6	74.6	74.6	76.5	70.9	83.5	55.8
	90	87.4	87.4	88.1	87.9	95.4	72.3	84.9	84.9	85.0	85.0	92.0	71.0	82.0	82.0	82.0	82.0	88.0	69.5	78.6	78.6	78.7	78.7	83.7	67.8
3000	75	79.5	68.8	87.6	52.8	96.1	35.8	76.8	67.4	84.4	51.5	92.5	34.5	73.5	65.9	80.7	50.0	88.4	33.1	69.8	64.1	76.6	48.4	83.9	31.5
	80	80.7	80.7	87.7	65.8	96.2	49.2	78.3	78.3	84.6	64.4	92.6	47.9	75.4	75.4	80.9	62.8	88.6	46.5	72.2	72.2	76.8	61.1	84.1	45.0
	85	85.1	85.1	88.1	78.8	96.4	62.6	82.6	82.6	85.0	77.4	92.7	61.1	79.6	79.6	81.5	75.9	88.7	59.6	76.3	76.3	77.5	74.2	84.3	58.0
	90	89.5	89.5	89.6	89.6	96.5	75.4	86.9	86.9	87.0	87.0	93.0	74.1	83.8	83.8	83.9	83.9	89.0	72.5	80.4	80.4	80.5	80.5	84.6	70.9

Note: All temperatures are in degrees Fahrenheit. Airflow is in cfm.

Table PD-1— Gross Cooling Capacities (kW) TWA075A Heat Pump with TWE075A Air Handler (SI)

m³/h	Enter. Dry Bulb (°C)	Ambient Temperature (°C)																							
		29.4			35.0				40.6			46.1													
		16.1		19.4	16.1		19.4		22.8		16.1		19.4		22.8										
		Total	Sens.	Total	Sens.	Total	Sens.	Total	Sens.	Total	Sens.	Total	Sens.	Total	Sens.	Total	Sens.	Total	Sens.						
3823	24	22.2	17.7	24.5	14.7	27.1	10.0	21.4	17.3	23.7	14.4	26.1	9.6	20.5	16.9	22.7	14.0	25.0	9.3	19.5	16.4	21.6	13.5	23.7	8.8
	27	22.3	20.7	24.6	17.0	27.1	13.1	21.6	20.4	23.7	16.7	26.1	12.8	20.7	19.9	22.7	16.2	25.0	12.4	19.8	19.5	21.6	15.7	23.8	11.9
	29	22.9	22.9	24.6	20.0	27.1	16.2	22.3	22.3	23.8	19.6	26.1	15.9	21.5	21.5	22.8	19.2	25.0	15.5	20.7	20.7	21.7	18.7	23.8	15.0
	32	24.1	24.1	24.8	23.1	27.1	19.3	23.4	23.4	23.9	22.7	26.2	18.9	22.7	22.7	23.0	22.3	25.1	18.5	21.8	21.8	22.0	21.8	23.9	18.0
4248	24	22.6	18.6	25.0	14.5	27.5	10.2	21.8	18.2	24.1	14.1	26.5	9.8	20.9	17.7	23.1	13.7	25.3	9.4	19.9	17.2	21.9	13.2	24.1	9.0
	27	22.8	21.9	25.0	17.9	27.5	13.6	22.1	21.5	24.1	17.4	26.5	13.2	21.2	21.1	23.1	17.0	25.4	12.8	20.2	20.2	21.9	16.5	24.1	12.4
	29	23.7	23.7	25.1	21.1	27.5	17.0	23.0	23.0	24.2	20.7	26.6	16.6	22.2	22.2	23.2	20.2	25.4	16.2	21.3	21.3	22.1	19.8	24.2	15.7
	32	24.9	24.9	25.3	24.4	27.6	20.2	24.2	24.2	24.5	24.0	26.6	19.9	23.4	23.4	23.4	23.4	25.5	19.4	22.4	22.4	22.5	22.5	24.2	18.9
4673	24	23.0	19.4	25.3	15.0	27.8	10.3	22.2	19.0	24.4	14.6	26.8	10.0	21.2	18.5	23.4	14.2	25.6	9.6	20.2	18.0	22.2	13.7	24.3	9.1
	27	23.3	23.0	25.4	18.5	27.9	14.0	22.4	22.4	24.5	18.2	26.8	13.6	21.6	21.6	23.4	17.7	25.7	13.2	20.7	20.7	22.2	17.2	24.4	12.8
	29	24.3	24.3	25.4	22.1	27.9	17.6	23.6	23.6	24.6	21.7	26.9	17.3	22.8	22.8	23.5	21.3	25.7	16.9	21.9	21.9	22.4	20.8	24.4	16.3
	32	25.6	25.6	25.8	25.7	27.9	21.2	24.9	24.9	24.9	26.9	20.8	24.0	24.0	24.0	24.0	25.8	20.3	23.0	23.0	23.0	23.0	24.5	19.9	
5098	24	23.3	20.1	25.6	15.5	28.1	10.5	22.5	19.7	24.7	15.1	27.1	10.1	21.5	19.3	23.6	14.6	25.9	9.7	20.4	18.8	22.4	14.2	24.6	9.2
	27	23.6	23.6	25.7	19.3	28.2	14.4	22.9	22.9	24.8	18.9	27.1	14.0	22.1	22.1	23.7	18.4	25.9	13.6	21.1	21.1	22.5	17.9	24.6	13.2
	29	24.9	24.9	25.8	23.1	28.2	18.3	24.2	24.2	24.9	22.7	27.1	17.9	23.3	23.3	23.8	22.2	26.0	17.5	22.3	22.3	22.7	21.7	24.7	17.0
	32	26.2	26.2	26.2	26.2	28.2	22.1	25.4	25.4	25.5	25.5	27.2	21.7	24.5	24.5	24.6	24.6	26.0	21.2	23.5	23.5	23.6	23.6	24.8	20.8

Note: All temperatures are in degrees Celsius. Airflow is in liters per second.



Performance Data (System)

Table PD-2 — Gross Cooling Capacities (MBh) TWA100A Heat Pump with TWE100A Air Handler (I-P)

CFM	Enter. Dry Bulb (°F)	Ambient Temperature (°F)																							
		85			95				105			115													
		Entering Wet Bulb (°F)			61			67			73			61		67		73							
Total	Sens.	Total Sens.	Total Sens.	Total	Sens.	Total Sens.	Total Sens.	Total	Sens.	Total Sens.	Total Sens.	Total	Sens.	Total Sens.	Total Sens.	Total	Sens.	Total Sens.	Total Sens.						
3000	75	101.6	80.9	111.8	67.1	122.7	45.2	97.7	79.0	107.6	65.4	118.1	43.6	93.6	76.9	103.2	63.6	113.2	41.9	89.4	74.8	98.6	61.7	108.2	40.1
	80	102.1	94.6	112.0	77.2	122.7	59.2	98.4	92.6	107.8	75.3	118.0	57.5	94.4	90.6	103.4	73.5	113.2	55.7	90.4	88.6	98.8	71.5	108.2	53.8
	85	104.6	104.6	112.1	90.6	122.8	72.8	101.3	101.3	107.9	88.7	118.2	71.1	97.9	97.9	103.5	86.7	113.4	69.3	94.3	94.3	98.9	84.6	108.4	67.4
	90	109.6	109.6	112.7	104.1	122.9	86.4	106.3	106.3	108.6	102.2	118.3	84.6	102.8	102.8	104.4	100.2	113.5	82.8	99.1	99.1	100.1	98.2	108.5	80.7
3325	75	103.4	84.5	113.7	65.6	124.6	46.0	99.4	82.5	109.4	63.8	119.8	44.4	95.2	80.5	104.8	61.9	114.8	42.7	90.9	78.3	100.1	59.9	109.6	40.8
	80	104.3	99.5	113.9	80.6	124.6	61.1	100.4	97.5	109.5	78.7	119.8	59.3	96.4	95.5	104.8	76.6	114.9	57.5	92.0	92.0	100.2	74.6	109.7	55.6
	85	107.8	107.8	114.0	95.0	124.7	75.9	104.4	104.4	109.6	93.1	120.0	74.1	100.8	100.8	105.2	91.1	115.0	72.3	97.0	97.0	100.6	89.0	109.9	70.4
	90	113.0	113.0	114.9	109.8	124.8	90.6	109.5	109.5	110.8	107.9	120.0	88.6	105.8	105.8	106.5	105.9	115.1	86.7	102.0	102.0	101.9	101.9	110.0	84.7
3650	75	105.0	88.0	115.3	67.7	126.1	46.8	100.9	85.9	110.8	65.8	121.2	45.0	96.6	83.9	106.1	63.9	116.1	43.2	92.2	81.7	101.3	62.0	110.8	41.3
	80	106.2	104.2	115.4	83.8	126.1	62.8	102.3	102.3	110.9	81.7	121.3	61.1	98.0	98.0	106.2	79.7	116.2	59.2	94.3	94.3	101.4	77.6	111.0	57.4
	85	110.6	110.6	115.6	99.3	126.3	78.8	107.0	107.0	111.2	97.3	121.4	77.0	103.3	103.3	106.7	95.3	116.4	75.2	99.4	99.4	102.0	93.3	111.1	73.3
	90	115.9	115.9	117.0	115.4	126.3	94.4	112.3	112.3	112.2	112.2	121.5	92.5	108.4	108.4	108.4	108.4	116.5	90.5	104.5	104.5	104.4	104.4	111.3	88.5
3975	75	106.3	91.3	116.6	69.7	127.5	47.4	102.2	89.3	112.0	67.8	122.4	45.6	97.9	87.2	107.3	65.9	117.2	43.7	93.4	85.0	102.4	63.9	111.8	41.9
	80	107.4	107.4	116.7	86.6	127.5	64.5	103.9	103.9	112.1	84.7	122.5	62.7	100.1	100.1	107.4	82.6	117.3	60.9	96.2	96.2	102.5	80.5	112.0	59.0
	85	113.0	113.0	117.1	103.4	127.6	81.6	109.3	109.3	112.7	101.5	122.7	79.8	105.5	105.5	108.1	99.4	117.5	78.0	101.5	101.5	103.3	97.4	112.2	76.1
	90	118.5	118.5	118.4	118.4	127.7	98.2	114.8	114.8	114.7	114.7	122.8	96.3	110.8	110.8	110.7	110.7	117.6	94.3	106.6	106.6	106.6	106.6	112.4	92.3

Note: All temperatures are in degrees Fahrenheit. Airflow is in cfm.

Table PD-2 — Gross Cooling Capacities (kW) TWA100A Heat Pump with TWE100A Air Handler (SI)

m³/h	Enter. Dry Bulb (°C)	Ambient Temperature (°C)																							
		29.4			35.0				40.6			46.1													
		Entering Wet Bulb (°C)			16.1			19.4			22.8			16.1		19.4		22.8							
Total	Sens.	Total Sens.	Total Sens.	Total	Sens.	Total Sens.	Total Sens.	Total	Sens.	Total Sens.	Total Sens.	Total	Sens.	Total Sens.	Total Sens.	Total	Sens.	Total Sens.	Total Sens.						
5098	24	29.7	23.7	32.7	19.7	35.9	13.2	28.6	23.1	31.5	19.1	34.6	12.8	27.4	22.5	30.2	18.6	33.1	12.3	26.2	21.9	28.9	18.1	31.7	11.8
	27	29.9	27.7	32.8	22.6	35.9	17.3	28.8	27.1	31.6	22.1	34.6	16.8	27.6	26.5	30.3	21.5	33.2	16.3	26.5	25.9	28.9	20.9	31.7	15.8
	29	30.6	30.6	32.8	26.5	35.9	21.3	29.7	29.7	31.6	26.0	34.6	20.8	28.7	28.7	30.3	25.4	33.2	20.3	27.6	27.6	29.0	24.8	31.7	19.7
	32	32.1	32.1	33.0	30.5	36.0	25.3	31.1	31.1	31.8	29.9	34.6	24.8	30.1	30.1	30.6	29.3	33.2	24.2	29.0	29.0	29.3	28.8	31.8	23.6
5648	24	30.3	24.7	33.3	19.2	36.5	13.5	29.1	24.2	32.0	18.7	35.1	13.0	27.9	23.6	30.7	18.1	33.6	12.5	26.6	22.9	29.3	17.5	32.1	11.9
	27	30.5	29.1	33.3	23.6	36.5	17.9	29.4	28.6	32.1	23.0	35.1	17.4	28.2	28.0	30.7	22.4	33.6	16.8	26.9	26.9	29.3	21.8	32.1	16.3
	29	31.6	31.6	33.4	27.8	36.5	22.2	30.6	30.6	32.1	27.2	35.1	21.7	29.5	29.5	30.8	26.7	33.7	21.2	28.4	28.4	29.4	26.1	32.2	20.6
	32	33.1	33.1	33.6	32.2	36.5	26.5	32.1	32.1	32.4	31.6	35.1	25.9	31.0	31.0	31.2	31.0	33.7	25.4	29.9	29.9	29.8	29.8	32.2	24.8
6203	24	30.7	25.8	33.8	19.8	36.9	13.7	29.5	25.2	32.4	19.3	35.5	13.2	28.3	24.6	31.1	18.7	34.0	12.7	27.0	23.9	29.7	18.1	32.5	12.1
	27	31.1	30.5	33.8	24.5	36.9	18.4	30.0	29.9	32.5	23.9	35.5	17.9	28.7	28.7	31.1	23.3	34.0	17.3	27.6	27.6	29.7	22.7	32.5	16.8
	29	32.4	32.4	33.8	29.1	37.0	23.1	31.3	31.3	32.6	28.5	35.6	22.6	30.2	30.2	31.2	27.9	34.1	22.0	29.1	29.1	29.9	27.3	32.5	21.5
	32	33.9	33.9	34.3	33.8	37.0	27.6	32.9	32.9	32.8	32.8	35.6	27.1	31.8	31.8	31.7	31.7	34.1	26.5	30.6	30.6	30.6	30.6	32.6	25.9
6754	24	31.1	26.7	34.1	20.4	37.3	13.9	29.9	26.1	32.8	19.9	35.9	13.3	28.7	25.5	31.4	19.3	34.3	12.8	27.3	24.9	30.0	18.7	32.7	12.3
	27	31.5	31.5	34.2	25.4	37.3	18.9	30.4	30.4	32.8	24.8	35.9	18.4	29.3	29.3	31.4	24.2	34.4	17.8	28.2	28.2	30.0	23.6	32.8	17.3
	29	33.1	33.1	34.3	30.3	37.4	23.9	32.0	32.0	33.0	29.7	35.9	23.4	30.9	30.9	31.6	29.1	34.4	22.8	29.7	29.7	30.3	28.5	32.9	22.3
	32	34.7	34.7	34.7	34.7	37.4	28.8	33.6	33.6	33.6	33.6	35.9	28.2	32.4	32.4	32.4	32.4	34.4	27.6	31.2	31.2	31.2	31.2	32.9	27.0

Note: All temperatures are in degrees Celsius. Airflow is in liters per second.



Performance Data (System)

Table PD-3 — Gross Cooling Capacities (MBh) TWA155A Heat Pump with TWE155A Air Handler (I-P)

		Ambient Temperature (°F)																							
		85			95			105			115														
CFM	Enter. Dry Bulb (°F)	Entering Wet Bulb (°F)																							
		61	67	73	61	67	73	61	67	73	61	67	73												
		Total	Sens.	Total	Sens.	Total	Sens.	Total	Sens.	Total	Sens.	Total	Sens.	Total	Sens.										
4500	75	152.8	121.6	169.0	101.2	186.3	68.7	147.6	119.0	163.1	98.8	179.6	66.4	141.5	116.0	156.2	96.0	171.9	63.7	134.4	112.5	148.4	92.9	163.4	60.8
	80	153.5	142.2	169.3	117.1	186.4	90.4	148.5	139.6	163.5	114.7	179.7	87.9	142.6	136.6	156.4	111.4	172.1	85.0	135.8	133.3	148.7	108.0	163.7	82.0
	85	157.6	157.6	169.5	137.4	186.6	111.5	153.3	153.3	163.7	134.8	180.0	109.0	148.1	148.1	156.9	131.8	172.5	106.2	142.1	142.1	149.2	128.4	164.1	103.1
	90	165.7	165.7	170.4	158.1	186.8	132.2	161.1	161.1	164.8	155.5	180.2	129.6	155.7	155.7	158.2	152.6	172.7	126.6	149.6	149.6	150.9	149.3	164.3	123.4
5000	75	155.8	127.4	172.1	99.7	189.4	70.0	150.4	124.7	166.0	97.1	182.4	67.6	144.0	121.6	158.8	94.2	174.5	64.9	136.7	118.1	150.8	90.9	165.7	61.8
	80	156.9	150.0	172.2	122.3	189.5	93.4	151.8	147.5	166.1	119.7	182.6	90.9	145.7	144.4	159.1	116.6	174.7	88.1	138.7	138.7	151.1	113.1	166.0	84.9
	85	162.9	162.9	172.7	144.6	189.8	116.5	158.3	158.3	166.6	141.9	182.9	114.0	152.8	152.8	159.6	138.9	175.1	111.2	146.5	146.5	151.8	135.5	166.5	108.0
	90	171.3	171.3	174.1	167.4	189.9	138.9	166.4	166.4	168.3	164.8	183.1	136.2	160.7	160.7	160.9	160.9	175.4	133.2	154.3	154.3	154.4	154.4	166.8	129.9
5500	75	158.3	132.9	174.6	103.0	191.8	71.3	152.8	130.2	168.3	100.5	184.7	68.7	146.2	127.0	161.0	97.5	176.5	65.9	138.8	123.5	152.7	94.2	167.5	62.7
	80	160.1	157.7	174.8	127.4	192.0	96.3	154.1	154.1	168.6	124.6	184.9	93.8	148.6	148.6	161.3	121.5	176.9	90.9	142.3	142.3	153.1	118.0	168.0	87.8
	85	167.4	167.4	175.3	151.5	192.3	121.3	162.6	162.6	169.2	148.8	185.3	118.8	156.8	156.8	162.0	145.7	177.1	115.4	150.3	150.3	154.0	142.3	168.3	112.1
	90	176.1	176.1	177.5	176.4	192.6	145.3	171.0	171.0	171.2	171.2	185.6	142.6	165.0	165.0	165.2	165.2	177.6	139.6	158.3	158.3	158.5	158.5	168.9	136.2
6000	75	160.5	138.2	176.8	106.3	193.9	72.2	154.8	135.5	170.3	103.7	186.6	69.6	148.1	132.3	162.8	100.7	178.3	66.7	140.6	128.7	154.4	97.4	169.1	63.6
	80	162.6	162.5	177.0	132.2	194.1	99.1	157.7	157.7	170.6	129.4	186.9	96.5	151.9	151.9	163.2	126.3	178.7	93.7	145.4	145.4	154.8	122.7	169.7	90.5
	85	171.5	171.5	177.7	158.2	194.3	125.6	166.4	166.4	171.4	155.5	187.1	122.9	160.4	160.4	164.1	152.4	179.0	119.8	153.6	153.6	156.1	148.9	170.1	116.4
	90	180.4	180.4	180.6	180.6	194.8	151.5	175.1	175.1	175.2	175.2	187.6	148.8	168.9	168.9	169.0	169.0	179.5	145.7	161.9	161.9	162.1	162.1	170.6	142.3

Note: All temperatures are in degrees Fahrenheit. Airflow is in cfm.

Table PD-3 — Gross Cooling Capacities (kW) TWA155A Heat Pump with TWE155A Air Handler (SI)

		Ambient Temperature (°C)																							
		29.4			35.0			40.6			46.1														
m³/h	Enter. Dry Bulb (°C)	Entering Wet Bulb (°C)																							
		16.1	19.4	22.8	16.1	19.4	22.8	16.1	19.4	22.8	16.1	19.4	22.8												
		Total	Sens.	Total	Sens.	Total	Sens.	Total	Sens.	Total	Sens.	Total	Sens.	Total	Sens.										
7646	24	44.7	35.6	49.5	29.6	54.6	20.1	43.2	34.8	47.8	28.9	52.6	19.4	41.4	34.0	45.7	28.1	50.3	18.7	39.4	32.9	43.5	27.2	47.8	17.8
	27	44.9	41.6	49.6	34.3	54.6	26.5	43.5	40.9	47.9	33.6	52.6	25.7	41.7	40.0	45.8	32.6	50.4	24.9	39.8	39.0	43.5	31.6	47.9	24.0
	29	46.1	46.1	49.6	40.2	54.6	32.6	44.9	44.9	47.9	39.5	52.7	31.9	43.4	43.4	45.9	38.6	50.5	31.1	41.6	41.6	43.7	37.6	48.0	30.2
	32	48.5	48.5	49.9	46.3	54.7	38.7	47.2	47.2	48.2	45.5	52.8	37.9	45.6	45.6	46.3	44.7	50.6	37.1	43.8	43.8	44.2	43.7	48.1	36.1
8496	24	45.6	37.3	50.4	29.2	55.4	20.5	44.0	36.5	48.6	28.4	53.4	19.8	42.2	35.6	46.5	27.6	51.1	19.0	40.0	34.6	44.2	26.6	48.5	18.1
	27	46.0	43.9	50.4	35.8	55.5	27.4	44.4	43.2	48.6	35.0	53.5	26.6	42.7	42.3	46.6	34.1	51.2	25.8	40.6	40.6	44.2	33.1	48.6	24.9
	29	47.7	47.7	50.6	42.3	55.6	34.1	46.3	46.3	48.8	41.6	53.6	33.4	44.7	44.7	46.7	40.7	51.3	32.5	42.9	42.9	44.4	39.7	48.7	31.6
	32	50.1	50.1	51.0	49.0	55.6	40.7	48.7	48.7	49.3	48.3	53.6	39.9	47.1	47.1	47.1	47.1	51.3	39.0	45.2	45.2	45.2	45.2	48.8	38.0
9346	24	46.4	38.9	51.1	30.2	56.2	20.9	44.7	38.1	49.3	29.4	54.1	20.1	42.8	37.2	47.1	28.6	51.7	19.3	40.6	36.2	44.7	27.6	49.0	18.4
	27	46.9	46.2	51.2	37.3	56.2	28.2	45.1	45.1	49.4	36.5	54.1	27.5	43.5	43.5	47.2	35.6	51.8	26.6	41.7	41.7	44.8	34.6	49.2	25.7
	29	49.0	49.0	51.3	44.4	56.3	35.5	47.6	47.6	49.5	43.6	54.3	34.8	45.9	45.9	47.4	42.7	51.8	33.8	44.0	44.0	45.1	41.7	49.3	32.8
	32	51.6	51.6	52.0	51.7	56.4	42.6	50.1	50.1	50.1	50.1	54.3	41.8	48.3	48.3	48.4	48.4	52.0	40.9	46.4	46.4	46.4	46.4	49.4	39.9
10195	24	47.0	40.5	51.8	31.1	56.8	21.1	45.3	39.7	49.9	30.4	54.6	20.4	43.4	38.7	47.7	29.5	52.2	19.5	41.2	37.7	45.2	28.5	49.5	18.6
	27	47.6	47.6	51.8	38.7	56.8	29.0	46.2	46.2	50.0	37.9	54.7	28.3	44.5	44.5	47.8	37.0	52.3	27.4	42.6	42.6	45.3	35.9	49.7	26.5
	29	50.2	50.2	52.0	46.3	56.9	36.8	48.7	48.7	50.2	45.5	54.8	36.0	47.0	47.0	48.1	44.6	52.4	35.1	45.0	45.0	45.7	43.6	49.8	34.1
	32	52.8	52.8	52.9	52.9	57.0	44.4	51.3	51.3	51.3	51.3	54.9	43.6	49.4	49.4	49.5	49.5	52.6	42.7	47.4	47.4	47.5	47.5	50.0	41.7

Note: All temperatures are in degrees Celsius. Airflow is in liters per second.



Performance Data (System)

Table PD-4 — Gross Cooling Capacities (MBh) TWA200A Heat Pump with TWE200A Air Handler (I-P)

CFM	Enter. Dry Bulb (°F)	Ambient Temperature (°F)																							
		85			95			105			115														
		Entering Wet Bulb (°F)			Entering Wet Bulb (°F)			Entering Wet Bulb (°F)			Entering Wet Bulb (°F)														
	61	67	73	61	67	73	61	67	73	61	67	73													
	Total	Sens.	Total Sens.	Total Sens.	Total Sens.	Total Sens.	Total Sens.	Total Sens.	Total Sens.	Total Sens.	Total Sens.	Total Sens.													
6000	75	200.7	159.3	220.9	132.5	242.6	89.4	192.9	155.4	212.4	129.1	233.3	86.1	184.8	151.3	203.6	125.5	223.6	82.8	176.4	147.1	194.5	121.8	213.6	79.3
	80	201.5	186.0	221.2	152.1	242.5	117.0	194.0	182.1	212.8	148.5	233.3	113.4	186.2	178.1	204.0	144.7	223.7	109.8	178.1	174.0	194.7	140.4	213.8	106.2
	85	206.2	206.2	221.4	178.3	242.8	143.7	199.7	199.7	213.0	174.4	233.6	140.2	192.9	192.9	204.3	170.5	224.0	136.5	185.8	185.8	195.2	166.4	214.1	132.8
	90	216.2	216.2	222.3	204.7	243.0	170.3	209.5	209.5	214.2	200.8	233.8	166.8	202.5	202.5	205.8	196.9	224.1	162.6	195.2	195.2	197.2	193.0	214.3	158.7
6675	75	204.4	166.6	224.8	129.6	246.5	91.1	196.4	162.6	216.1	125.9	236.9	87.8	188.1	158.5	207.0	122.1	226.9	84.3	179.4	154.2	197.6	118.3	216.6	80.6
	80	205.8	195.9	225.1	159.0	246.5	120.7	198.1	192.0	216.2	154.9	236.9	117.2	190.2	188.0	207.2	151.0	227.1	113.6	181.5	181.5	197.9	146.9	216.8	109.8
	85	212.7	212.7	225.3	187.3	246.7	149.9	205.9	205.9	216.7	183.3	237.2	146.3	198.8	198.8	207.7	179.3	227.4	142.7	191.4	191.4	198.6	175.3	217.2	138.9
	90	223.1	223.1	226.9	216.3	246.8	178.4	216.1	216.1	218.7	212.4	237.3	174.6	208.8	208.8	210.2	208.5	227.6	170.8	201.2	201.2	201.0	201.0	217.4	166.8
7350	75	207.6	173.6	228.0	133.8	249.6	92.7	199.4	169.5	219.1	130.1	239.8	89.1	190.8	165.4	209.8	126.3	229.6	85.5	182.1	161.1	200.2	122.4	219.1	81.8
	80	209.7	205.5	228.1	165.1	249.7	124.3	202.0	201.6	219.3	161.2	239.9	120.8	193.6	193.6	210.0	157.2	229.8	117.1	186.1	186.1	200.5	153.0	219.4	113.4
	85	218.4	218.4	228.6	195.9	250.0	155.8	211.3	211.3	219.9	192.0	240.3	152.2	203.9	203.9	210.8	187.9	230.2	148.5	196.2	196.2	201.5	183.8	219.8	144.8
	90	229.1	229.1	231.1	227.5	250.1	186.4	221.9	221.9	221.7	221.7	240.4	182.5	214.3	214.3	214.1	214.1	230.4	178.6	206.3	206.3	206.2	206.2	220.0	174.6
8025	75	210.3	180.3	230.8	137.8	252.3	93.8	202.0	176.2	221.6	134.1	242.3	90.3	193.3	172.0	212.1	130.3	231.9	86.6	184.4	167.7	202.4	126.4	221.1	82.8
	80	212.4	212.4	231.0	171.2	252.4	127.7	205.3	205.3	221.9	167.2	242.5	124.2	197.8	197.8	212.5	163.1	232.1	120.5	190.1	190.1	202.8	159.0	221.5	116.7
	85	223.4	223.4	231.6	204.3	252.7	161.5	216.1	216.1	222.8	200.3	242.8	157.9	208.4	208.4	213.6	196.2	232.3	153.7	200.5	200.5	204.1	192.1	221.7	149.7
	90	234.5	234.5	234.3	234.3	252.9	194.0	227.0	227.0	226.8	226.8	243.1	190.1	219.0	219.0	218.9	218.9	232.8	186.2	210.8	210.8	210.7	210.7	222.2	182.1

Note: All temperatures are in degrees Fahrenheit. Airflow is in cfm.

Table PD-4 — Gross Cooling Capacities (kW) TWA200A Heat Pump with TWE200A Air Handler (SI)

m³/h	Enter. Dry Bulb (°C)	Ambient Temperature (°C)																							
		29.4			35.0			40.6			46.1														
		Entering Wet Bulb (°C)			Entering Wet Bulb (°C)			Entering Wet Bulb (°C)			Entering Wet Bulb (°C)														
	16.1	19.4	22.8	16.1	19.4	22.8	16.1	19.4	22.8	16.1	19.4	22.8													
	Total	Sens.	Total Sens.	Total Sens.	Total Sens.	Total Sens.	Total Sens.	Total Sens.	Total Sens.	Total Sens.	Total Sens.	Total Sens.													
10195	24	58.8	46.7	64.7	38.8	71.0	26.2	56.5	45.5	62.2	37.8	68.3	25.2	54.1	44.3	59.6	36.7	65.5	24.2	51.6	43.1	57.0	35.7	62.5	23.2
	27	59.0	54.5	64.8	44.5	71.0	34.2	56.8	53.3	62.3	43.5	68.3	33.2	54.5	52.1	59.7	42.4	65.5	32.2	52.1	50.9	57.0	41.1	62.6	31.1
	29	60.4	60.4	64.8	52.2	71.1	42.1	58.5	58.5	62.4	51.1	68.4	41.0	56.5	56.5	59.8	49.9	65.6	40.0	54.4	54.4	57.2	48.7	62.7	38.9
	32	63.3	63.3	65.1	59.9	71.2	49.9	61.3	61.3	62.7	58.8	68.5	48.8	59.3	59.3	60.3	57.7	65.6	47.6	57.2	57.2	57.7	56.5	62.7	46.5
11340	24	59.9	48.8	65.8	37.9	72.2	26.7	57.5	47.6	63.3	36.9	69.4	25.7	55.1	46.4	60.6	35.8	66.4	24.7	52.5	45.2	57.9	34.6	63.4	23.6
	27	60.3	57.4	65.9	46.6	72.2	35.4	58.0	56.2	63.3	45.4	69.4	34.3	55.7	55.0	60.7	44.2	66.5	33.3	53.1	53.1	57.9	43.0	63.5	32.2
	29	62.3	62.3	66.0	54.8	72.2	43.9	60.3	60.3	63.4	53.7	69.5	42.8	58.2	58.2	60.8	52.5	66.6	41.8	56.0	56.0	58.1	51.3	63.6	40.7
	32	65.3	65.3	66.4	63.3	72.2	52.2	63.3	63.3	64.0	62.2	69.5	51.1	61.1	61.1	61.6	61.1	66.6	50.0	58.9	58.9	58.9	58.9	63.7	48.8
12488	24	60.8	50.8	66.8	39.2	73.1	27.1	58.4	49.6	64.1	38.1	70.2	26.1	55.9	48.4	61.4	37.0	67.2	25.0	53.3	47.2	58.6	35.8	64.1	23.9
	27	61.4	60.2	66.8	48.3	73.1	36.4	59.1	59.0	64.2	47.2	70.3	35.4	56.7	56.7	61.5	46.0	67.3	34.3	54.5	54.5	58.7	44.8	64.2	33.2
	29	64.0	64.0	66.9	57.4	73.2	45.6	61.9	61.9	64.4	56.2	70.3	44.6	59.7	59.7	61.7	55.0	67.4	43.5	57.5	57.5	59.0	53.8	64.4	42.4
	32	67.1	67.1	67.7	66.6	73.2	54.6	65.0	65.0	64.9	64.9	70.4	53.4	62.7	62.7	62.7	62.7	67.5	52.3	60.4	60.4	60.4	60.4	64.4	51.1
13633	24	61.6	52.8	67.6	40.4	73.9	27.5	59.1	51.6	64.9	39.3	70.9	26.4	56.6	50.4	62.1	38.2	67.9	25.4	54.0	49.1	59.3	37.0	64.7	24.3
	27	62.2	62.2	67.6	50.1	73.9	37.4	60.1	60.1	65.0	49.0	71.0	36.4	57.9	57.9	62.2	47.8	68.0	35.3	55.7	55.7	59.4	46.5	64.9	34.2
	29	65.4	65.4	67.8	59.8	74.0	47.3	63.3	63.3	65.2	58.6	71.1	46.2	61.0	61.0	62.5	57.5	68.0	45.0	58.7	58.7	59.8	56.3	64.9	43.8
	32	68.7	68.7	68.6	68.6	74.1	56.8	66.5	66.5	66.4	66.4	71.2	55.7	64.1	64.1	64.1	64.1	68.2	54.5	61.7	61.7	61.7	61.7	65.1	53.3

Note: All temperatures are in degrees Celsius. Airflow is in liters per second.



Performance Data

(TWA075A)

Table PD-5 — Gross Cooling Performance (MBh) TWA075A Heat Pump Only (I-P)

ODTemp °F		Suction Reference Temperature °F					
		30	35	40	45	50	55
65	Head press psig	165	170	176	182	188	195
	Cap. Btu/1000	70.0	77.4	85.1	93.1	101.3	109.6
	OD Unit kW	4.58	4.67	4.78	4.89	5.02	5.14
75	Head press psig	191	197	203	209	215	222
	Cap. Btu/1000	68.2	75.2	82.5	90.1	97.8	105.6
	OD Unit kW	5.04	5.15	5.27	5.39	5.52	5.65
85	Head press psig	219	225	231	238	245	252
	Cap. Btu/1000	65.5	72.3	79.2	86.4	93.6	101.1
	OD Unit kW	5.59	5.71	5.84	5.97	6.10	6.24
95	Head press psig	250	256	263	270	277	284
	Cap. Btu/1000	62.3	68.7	75.3	82.0	88.9	95.9
	OD Unit kW	6.22	6.35	6.48	6.61	6.74	6.88
105	Head press psig	283	289	296	304	311	319
	Cap. Btu/1000	58.6	64.6	70.8	77.1	83.7	90.3
	OD Unit kW	6.93	7.06	7.18	7.31	7.45	7.59
115	Head press psig	318	325	332	340	347	355
	Cap. Btu/1000	54.4	60.0	65.8	71.8	78.0	84.4
	OD Unit kW	7.72	7.83	7.95	8.08	8.22	8.36

Table PD-5 — Gross Cooling Performance (kW) TWA075A Heat Pump Only (SI)

ODTemp °C		Suction Reference Temperature °C					
		-1.1	1.7	4.4	7.2	10	12.8
18.3	Head pressure (kPA)	1136	1173	1213	1255	1298	1343
	Capacity (kW)	20.5	22.6	24.9	27.2	29.7	32.1
	OD Unit Power (kW)	4.58	4.67	4.78	4.89	5.02	5.14
23.9	Head pressure (kPA)	1315	1355	1397	1440	1484	1531
	Capacity (kW)	20.0	22.0	24.2	26.4	28.6	30.9
	OD Unit Power (kW)	5.04	5.15	5.27	5.39	5.52	5.65
29.4	Head pressure (kPA)	1509	1552	1596	1642	1689	1738
	Capacity (kW)	19.2	21.2	23.2	25.3	27.4	29.6
	OD Unit Power (kW)	5.59	5.71	5.84	5.97	6.10	6.24
35.0	Head pressure (kPA)	1721	1766	1812	1860	1909	1959
	Capacity (kW)	18.3	20.1	22.0	24.0	26.0	28.1
	OD Unit Power (kW)	6.22	6.35	6.48	6.61	6.74	6.88
40.6	Head pressure (kPA)	1948	1995	2043	2093	2144	2197
	Capacity (kW)	17.2	18.9	20.7	22.6	24.5	26.5
	OD Unit Power (kW)	6.93	7.06	7.18	7.31	7.45	7.59
46.1	Head pressure (kPA)	2192	2240	2290	2341	2395	2450
	Capacity (kW)	15.9	17.6	19.3	21.0	22.8	24.7
	OD Unit Power (kW)	7.72	7.83	7.95	8.08	8.22	8.36
48.9	Head pressure (kPA)	2320	2369	2419	2471	2526	2583
	Capacity (kW)	15.3	16.9	18.5	20.2	22.0	23.8
	OD Unit Power (kW)	8.13	8.24	8.36	8.49	8.62	8.76



Performance Data

(TWA100A)

Table PD-6— Gross Cooling Performance (MBh) TWA100A Heat Pump Only (I-P)

ODTemp °F		Suction Reference Temperature °F					
		30	35	40	45	50	55
65	Head press psig	175	181	187	194	201	208
	Cap. Btu/1000	94.8	104.0	113.6	123.5	133.7	144.2
	OD Unit kW	6.26	6.41	6.57	6.74	6.93	7.12
75	Head press psig	200	207	213	220	227	235
	Cap. Btu/1000	90.4	99.1	108.1	117.5	127.3	137.3
	OD Unit kW	6.92	7.08	7.25	7.44	7.64	7.85
85	Head press psig	229	235	242	250	257	265
	Cap. Btu/1000	85.7	93.9	102.5	111.5	120.8	130.4
	OD Unit kW	7.70	7.88	8.07	8.27	8.49	8.71
95	Head press psig	259	266	274	282	290	298
	Cap. Btu/1000	80.7	88.6	96.8	105.4	114.2	123.3
	OD Unit kW	8.60	8.79	9.00	9.22	9.44	9.67
105	Head press psig	293	300	308	316	325	334
	Cap. Btu/1000	75.5	83.0	91.0	99.2	107.6	116.2
	OD Unit kW	9.60	9.82	10.05	10.28	10.51	10.74
115	Head press psig	328	337	345	354	363	372
	Cap. Btu/1000	70.0	77.4	85.0	92.9	100.9	109.0
	OD Unit kW	10.72	10.96	11.21	11.45	11.69	11.92

Table PD-6 — Gross Cooling Performance (kW) TWA100A Heat Pump Only (SI)

ODTemp °C		Suction Reference Temperature °C					
		-1.1	1.7	4.4	7.2	10	12.8
18.3	Head pressure (kPA)	1206	1247	1290	1336	1383	1432
	Capacity (kW)	27.7	30.4	33.3	36.2	39.2	42.2
	OD Unit Power (kW)	6.26	6.41	6.57	6.74	6.93	7.12
23.9	Head pressure (kPA)	1382	1425	1470	1518	1568	1621
	Capacity (kW)	26.5	29.0	31.7	34.4	37.3	40.2
	OD Unit Power (kW)	6.92	7.08	7.25	7.44	7.64	7.85
29.4	Head pressure (kPA)	1576	1622	1670	1721	1774	1829
	Capacity (kW)	25.1	27.5	30.0	32.7	35.4	38.2
	OD Unit Power (kW)	7.70	7.88	8.07	8.27	8.49	8.71
35.0	Head pressure (kPA)	1788	1837	1888	1941	1997	2055
	Capacity (kW)	23.6	25.9	28.3	30.9	33.5	36.1
	OD Unit Power (kW)	8.60	8.79	9.00	9.22	9.44	9.67
40.6	Head pressure (kPA)	2017	2069	2124	2181	2240	2300
	Capacity (kW)	22.1	24.3	26.6	29.0	31.5	34.0
	OD Unit Power (kW)	9.60	9.82	10.05	10.28	10.51	10.74
46.1	Head pressure (kPA)	2265	2321	2379	2440	2502	2565
	Capacity (kW)	20.5	22.7	24.9	27.2	29.5	31.9
	OD Unit Power (kW)	10.72	10.96	11.21	11.45	11.69	11.92



Performance Data (TWA155A)

Table PD-7 — Gross Cooling Performance (MBh) TWA155A Heat Pump Only (I-P)

ODTemp °F		Suction Reference Temperature °F					
		30	35	40	45	50	55
65	Head press psig	165	170	176	182	188	195
	Cap. Btu/1000	137.2	151.6	166.8	182.4	198.5	214.9
	OD Unit kW	9.13	9.33	9.54	9.77	10.02	10.27
75	Head press psig	191	197	203	209	215	222
	Cap. Btu/1000	133.6	147.5	161.8	176.6	191.6	207.0
	OD Unit kW	10.06	10.29	10.52	10.77	11.02	11.29
85	Head press psig	219	225	232	238	245	252
	Cap. Btu/1000	128.5	141.7	155.4	169.3	183.6	198.1
	OD Unit kW	11.16	11.40	11.65	11.91	12.18	12.46
95	Head press psig	250	256	263	270	277	284
	Cap. Btu/1000	122.2	134.7	147.6	160.8	174.3	188.1
	OD Unit kW	12.43	12.68	12.94	13.20	13.47	13.75
105	Head press psig	283	289	296	304	311	319
	Cap. Btu/1000	114.9	126.7	138.8	151.2	164.0	177.1
	OD Unit kW	13.85	14.10	14.35	14.61	14.89	15.17
115	Head press psig	318	325	332	340	347	355
	Cap. Btu/1000	106.7	117.7	129.1	140.8	152.9	165.4
	OD Unit kW	15.41	15.65	15.89	16.15	16.42	16.70

Table PD-7 — Gross Cooling Performance (kW) TWA155A Heat Pump Only (SI)

ODTemp °C		Suction Reference Temperature °C					
		-1.1	1.7	4.4	7.2	10.0	12.8
18.3	Head pressure (kPA)	1136	1174	1213	1255	1299	1343
	Capacity (kW)	40.2	44.4	48.8	53.4	58.1	62.9
	OD Unit Power (kW)	9.13	9.33	9.54	9.77	10.02	10.27
23.9	Head pressure (kPA)	1315	1355	1397	1440	1485	1532
	Capacity (kW)	39.1	43.2	47.4	51.7	56.1	60.6
	OD Unit Power (kW)	10.06	10.29	10.52	10.77	11.02	11.29
29.4	Head pressure (kPA)	1510	1552	1597	1642	1690	1738
	Capacity (kW)	37.6	41.5	45.5	49.6	53.8	58.0
	OD Unit Power (kW)	11.16	11.40	11.65	11.91	12.18	12.46
35.0	Head pressure (kPA)	1722	1767	1813	1860	1909	1960
	Capacity (kW)	35.8	39.5	43.2	47.1	51.0	55.1
	OD Unit Power (kW)	12.43	12.68	12.94	13.20	13.47	13.75
40.6	Head pressure (kPA)	1949	1996	2044	2093	2145	2197
	Capacity (kW)	33.6	37.1	40.6	44.3	48.0	51.9
	OD Unit Power (kW)	13.85	14.10	14.35	14.61	14.89	15.17
46.1	Head pressure (kPA)	2192	2241	2291	2342	2395	2451
	Capacity (kW)	31.2	34.5	37.8	41.2	44.8	48.4
	OD Unit Power (kW)	15.41	15.65	15.89	16.15	16.42	16.70



Performance Data

(TWA200A)

Table PD-8 — Gross Cooling Performance (MBh) TWA200A Heat Pump Only (I-P)

ODTemp ° F		Suction Reference Temperature °F					
		30	35	40	45	50	55
65	Head press psig	177	183	189	196	203	210
	Cap. Btu/1000	187.4	205.7	224.7	244.4	264.7	285.6
	OD Unit kW	12.50	12.81	13.14	13.49	13.86	14.25
75	Head press psig	203	209	216	223	230	238
	Cap. Btu/1000	178.8	196.0	213.9	232.6	252.1	272.1
	OD Unit kW	13.84	14.17	14.53	14.91	15.32	15.75
85	Head press psig	231	238	245	253	260	269
	Cap. Btu/1000	169.4	185.8	203.0	220.8	239.3	258.4
	OD Unit kW	15.42	15.79	16.18	16.60	17.04	17.49
95	Head press psig	262	269	277	285	293	302
	Cap. Btu/1000	159.6	175.3	191.7	208.8	226.4	244.5
	OD Unit kW	17.24	17.65	18.08	18.52	18.98	19.44
105	Head press psig	296	304	312	320	329	338
	Cap. Btu/1000	149.2	164.3	180.1	196.5	213.4	230.6
	OD Unit kW	19.29	19.74	20.20	20.68	21.15	21.62
115	Head press psig	332	340	349	358	367	377
	Cap. Btu/1000	138.5	153.1	168.4	184.1	200.2	216.5
	OD Unit kW	21.55	22.05	22.55	23.05	23.54	24.01

Table PD-8 — Gross Cooling Performance (kW) TWA200A Heat Pump Only (SI)

ODTemp °C		Suction Reference Temperature °C					
		-1.1	1.7	4.4	7.2	10.0	12.8
18.3	Head pressure (kPA)	1219	1261	1305	1351	1399	1449
	Capacity (kW)	54.9	60.2	65.8	71.5	77.5	83.6
	OD Unit Power (kW)	12.50	12.81	13.14	13.49	13.86	14.25
23.9	Head pressure (kPA)	1397	1441	1487	1536	1588	1642
	Capacity (kW)	52.3	57.4	62.6	68.1	73.8	79.7
	OD Unit Power (kW)	13.84	14.17	14.53	14.91	15.32	15.75
29.4	Head pressure (kPA)	1593	1640	1689	1741	1796	1852
	Capacity (kW)	49.6	54.4	59.4	64.7	70.1	75.7
	OD Unit Power (kW)	15.42	15.79	16.18	16.60	17.04	17.49
35.0	Head pressure (kPA)	1808	1857	1910	1965	2022	2081
	Capacity (kW)	46.7	51.3	56.1	61.1	66.3	71.6
	OD Unit Power (kW)	17.24	17.65	18.08	18.52	18.98	19.44
40.6	Head pressure (kPA)	2040	2093	2149	2207	2268	2329
	Capacity (kW)	43.7	48.1	52.7	57.5	62.5	67.5
	OD Unit Power (kW)	19.29	19.74	20.20	20.68	21.15	21.62
46.1	Head pressure (kPA)	2290	2348	2408	2470	2533	2597
	Capacity (kW)	40.5	44.8	49.3	53.9	58.6	63.4
	OD Unit Power (kW)	21.55	22.05	22.55	23.05	23.54	24.01



Performance Data (System)

Table PD-9 — Gross Heating Capacities (MBh)
TWA075A Heat Pump with TWE075A Air Handler At 2500 CFM (I-P)

Outdoor Temperature (°F)	Heating Capacity (Btu/1000) At				Total Power in Kilowatts At			
	Indicated Indoor Dry Bulb Temperature				Indicated Indoor Dry Bulb Temperature			
	60	70	75	80	60	70	75	80
-18	34.9	30.4	28.5	26.9	5.5	5.6	5.7	5.8
-13	35.5	31.5	30.0	28.6	5.5	5.6	5.7	5.9
-8	36.5	33.1	31.8	30.6	5.4	5.6	5.8	5.9
-3	37.9	35.0	34.0	33.2	5.4	5.6	5.8	6.0
2	39.7	37.5	36.7	36.1	5.4	5.7	5.9	6.1
7	42.0	40.3	39.7	39.3	5.4	5.7	6.0	6.2
12	44.8	43.5	43.1	42.9	5.5	5.8	6.1	6.3
17	48.0	47.1	46.9	46.8	5.5	5.9	6.2	6.5
22	51.7	51.1	51.0	50.9	5.6	6.0	6.3	6.6
27	55.8	55.4	55.3	55.3	5.7	6.2	6.4	6.8
32	60.3	60.1	60.0	60.0	5.8	6.3	6.6	6.9
37	65.0	64.8	64.7	64.7	5.9	6.5	6.8	7.1
42	69.9	69.7	69.6	69.5	6.0	6.6	6.9	7.3
47	75.1	74.8	74.7	74.5	6.2	6.8	7.1	7.5
52	80.6	80.2	79.9	79.6	6.3	7.0	7.3	7.6
57	86.2	85.6	85.3	84.9	6.5	7.1	7.5	7.8
62	92.0	91.2	90.8	90.2	6.7	7.3	7.7	8.0
67	97.8	96.8	96.2	95.6	6.9	7.5	7.9	8.2
72	103.7	102.5	101.9	101.2	7.1	7.7	8.1	8.4

Table PD-9 — Gross Heating Capacities (kW)
TWA075A Heat Pump with TWE075A Air Handler At 4247 m³/h (S)

Outdoor Temperature (°C)	Heating Capacity (kW) At				Total Power in Kilowatts At			
	Indicated Indoor Dry Bulb Temperature				Indicated Indoor Dry Bulb Temperature			
	15.6	21.1	23.9	26.7	15.6	21.1	23.9	26.7
-27.8	10.2	8.9	8.4	7.9	5.5	6.0	6.2	6.5
-25.0	10.4	9.2	8.8	8.4	5.6	6.1	6.3	6.6
-22.2	10.7	9.7	9.3	9.0	5.7	6.2	6.5	6.7
-19.4	11.1	10.3	10.0	9.7	5.8	6.3	6.6	6.9
-16.7	11.6	11.0	10.7	10.6	5.9	6.5	6.7	7.0
-13.9	12.3	11.8	11.6	11.5	6.0	6.6	6.9	7.2
-11.1	13.1	12.7	12.6	12.6	6.2	6.7	7.0	7.4
-8.3	14.1	13.8	13.7	13.7	6.3	6.9	7.2	7.5
-5.6	15.1	15.0	14.9	14.9	6.5	7.0	7.4	7.7
-2.8	16.3	16.2	16.2	16.2	6.6	7.2	7.5	7.9
0.0	17.7	17.6	17.6	17.6	6.8	7.4	7.7	8.1
2.8	19.0	19.0	19.0	18.9	6.9	7.6	7.9	8.3
5.6	20.5	20.4	20.4	20.3	7.1	7.8	8.1	8.5
8.3	22.0	21.9	21.9	21.8	7.3	8.0	8.4	8.8
11.1	23.6	23.5	23.4	23.3	7.5	8.2	8.6	9.0
13.9	25.2	25.1	25.0	24.9	7.7	8.4	8.8	9.2
16.7	26.9	26.7	26.6	26.4	7.9	8.7	9.1	9.5
19.4	28.6	28.3	28.2	28.0	8.1	8.9	9.3	9.8
22.2	30.4	30.0	29.8	29.6	8.4	9.2	9.6	10.0

Correction Factors - Other Airflows
 (Table Value x Correction Factor = Value at new airflow)

Airflow	2250 cfm	2750 cfm
	3822 m³/h	4672 m³/h
Heating Capacity	x0.99	x1.01
Compressor kW	x1.02	x0.98

Values at ARI Rating Conditions of:
 70F (21.1C) and 47/43F (8.3/6.1C)(High Temp.Cond.)
 70F (21.1C) and 17/15F (-8.3/-9.4C)(Low Temp. Cond)

Airflow = 2500 cfm (4247 m³/h)
 Heating Capacity (High Temp.) = 75,000 (21.82)
 Heating Capacity (Low Temp.) = 47,000 (13.84)
 Compressor Power (High Temp) = 5.41 kW
 Compressor Power (Low Temp) = 4.55 kW
 Coeff. Of Perf. (High Temp) = 3.2
 Coeff. Of Perf. (Low Temp) = 2.3
 Outdoor Fan Power = 550 watts
 Indoor Fan Power = 800 watts

Note:
 1. Rated with 25 feet of 1-3/8" suction and 1/2" liquid line.



Performance Data (System)

Table PD-10 — Gross Heating Capacities (MBh)
TWA100A Heat Pump with TWE100A Air Handler At 3325 CFM (I-P)

Outdoor Temperature (°F)	Heating Capacity (Btu/1000) At				Total Power in Kilowatts At			
	Indicated Indoor Dry Bulb Temperature				Indicated Indoor Dry Bulb Temperature			
	60	70	75	80	60	70	75	80
-18	21.9	39.6	43.0	44.8	5.6	7.3	7.9	8.4
-13	33.4	43.6	46.0	47.3	6.2	7.5	8.0	8.5
-8	40.8	47.5	49.2	50.2	6.6	7.6	8.1	8.6
-3	46.7	51.5	52.8	53.4	6.8	7.8	8.2	8.7
2	52.3	55.7	56.5	57.0	7.0	7.9	8.4	8.8
7	57.7	60.1	60.6	60.8	7.2	8.1	8.5	8.9
12	63.2	64.8	65.1	65.1	7.4	8.2	8.6	9.1
17	68.9	69.8	69.9	69.8	7.5	8.4	8.8	9.2
22	74.8	75.1	75.1	74.9	7.7	8.5	9.0	9.4
27	80.9	80.8	80.6	80.3	7.9	8.7	9.1	9.6
32	87.3	86.8	86.5	86.2	8.0	8.9	9.4	9.8
37	93.6	92.9	92.6	92.2	8.2	9.1	9.6	10.1
42	100.2	99.3	98.9	98.5	8.4	9.3	9.8	10.3
47	107.1	106.0	105.6	105.2	8.6	9.5	10.1	10.6
52	114.4	113.2	112.7	112.3	8.8	9.8	10.3	10.9
57	121.9	120.6	120.1	119.7	9.1	10.1	10.6	11.2
62	129.7	128.3	127.8	127.3	9.3	10.4	10.9	11.5
67	137.7	136.2	135.6	135.1	9.6	10.7	11.2	11.9
72	145.9	144.3	143.7	143.2	9.9	11.0	11.6	12.2

Table PD-10 — Gross Heating Capacities (kW)
TWA100A Heat Pump with TWE100A Air Handler At 5649 m³/h (SI)

Outdoor Temperature (°C)	Heating Capacity (kW) At				Total Power in Kilowatts At			
	Indicated Indoor Dry Bulb Temperature				Indicated Indoor Dry Bulb Temperature			
	15.6	21.1	23.9	26.7	15.6	21.1	23.9	26.7
-27.8	6.4	11.6	12.6	13.1	5.5	6.0	6.2	6.5
-25.0	9.8	12.8	13.5	13.9	5.6	6.1	6.3	6.6
-22.2	11.9	13.9	14.4	14.7	5.7	6.2	6.5	6.7
-19.4	13.7	15.1	15.4	15.6	5.8	6.3	6.6	6.9
-16.7	15.3	16.3	16.6	16.7	5.9	6.5	6.7	7.0
-13.9	16.9	17.6	17.8	17.8	6.0	6.6	6.9	7.2
-11.1	18.5	19.0	19.1	19.1	6.2	6.7	7.0	7.4
-8.3	20.2	20.4	20.5	20.4	6.3	6.9	7.2	7.5
-5.6	21.9	22.0	22.0	21.9	6.5	7.0	7.4	7.7
-2.8	23.7	23.7	23.6	23.5	6.6	7.2	7.5	7.9
0.0	25.6	25.4	25.3	25.2	6.8	7.4	7.7	8.1
2.8	27.4	27.2	27.1	27.0	6.9	7.6	7.9	8.3
5.6	29.3	29.1	29.0	28.8	7.1	7.8	8.1	8.5
8.3	31.3	31.0	30.9	30.8	7.3	8.0	8.4	8.8
11.1	33.5	33.1	33.0	32.9	7.5	8.2	8.6	9.0
13.9	35.7	35.3	35.2	35.0	7.7	8.4	8.8	9.2
16.7	38.0	37.6	37.4	37.3	7.9	8.7	9.1	9.5
19.4	40.3	39.9	39.7	39.6	8.1	8.9	9.3	9.8
22.2	42.7	42.3	42.1	41.9	8.4	9.2	9.6	10.0

Correction Factors - Other Airflows
 (Table Value x Correction Factor = Value at new airflow)

Airflow	3000 cfm	3675 cfm
	5097 m³/h	6243 m³/h
Heating Capacity	x0.99	x1.01
Compressor kW	x1.02	x0.98

Values at ARI Rating Conditions of:
 70F (21.1C) and 47/43F (8.3/6.1C)(High Temp. Cond.)
 70F (21.1C) and 17/15F (-8.3/-9.4C)(Low Temp. Cond.)

Airflow = 3325 cfm (5649 m³/h)
 Heating Capacity (High Temp.) = 106,000 (31.05)
 Heating Capacity (Low Temp.) = 69,000 (20.29)
 Compressor Power (High Temp.) = 7.61 kW
 Compressor Power (Low Temp.) = 6.38 kW
 Coeff. Of Perf. (High Temp.) = 3.30
 Coeff. Of Perf. (Low Temp.) = 2.4
 Outdoor Fan Power = 644 watts
 Indoor Fan Power = 1,170 watts

Note:
 1. Rated with 25 feet of 1-3/8" suction and 1/2" liquid line.



Performance Data (System)

Table PD-11 — Gross Heating Capacities (MBh)
TWA155B Heat Pump with TWE155B Air Handler At 5000 CFM (I-P)

Outdoor Temperature (°F)	Heating Capacity (BTUH/1000) At				Total Power in Kilowatts At			
	Indicated Indoor Dry Bulb Temperature				Indicated Indoor Dry Bulb Temperature			
	60	70	75	80	60	70	75	80
-18	69.7	60.9	57.2	54.0	11.1	11.4	11.5	11.8
-13	71.1	63.2	60.2	57.4	11.0	11.3	11.6	11.8
-8	73.1	66.4	63.9	61.6	11.0	11.4	11.6	12.0
-3	76.0	70.4	68.4	66.8	10.9	11.4	11.7	12.1
2	79.8	75.4	73.9	72.7	10.9	11.5	11.9	12.3
7	84.5	81.1	80.0	79.3	11.0	11.6	12.1	12.6
12	90.2	87.7	87.0	86.6	11.1	11.8	12.3	12.8
17	96.7	95.1	94.6	94.4	11.2	12.0	12.5	13.1
22	104.2	103.2	102.9	102.8	11.3	12.2	12.8	13.4
27	112.6	111.9	111.8	111.8	11.5	12.5	13.1	13.7
32	121.8	121.4	121.3	121.3	11.7	12.8	13.4	14.1
37	131.3	131.0	130.8	130.7	12.0	13.1	13.8	14.4
42	141.4	140.9	140.7	140.5	12.3	13.4	14.1	14.8
47	151.9	151.3	151.0	150.6	12.6	13.8	14.5	15.2
52	163.0	162.2	161.6	161.0	12.9	14.1	14.8	15.6
57	174.4	173.3	172.5	171.7	13.2	14.5	15.2	15.9
62	186.2	184.6	183.6	182.6	13.6	14.9	15.6	16.3
67	198.0	196.0	194.8	193.5	14.0	15.3	16.0	16.7
72	210.0	207.6	206.2	204.8	14.4	15.7	16.4	17.1

Table PD-11 — Gross Heating Capacities (kW)
TWA155B Heat Pump with TWE155B Air Handler At 8494 m³/h (SI)

Outdoor Temperature (°C)	Heating Capacity (kW) At				Total Power in Kilowatts At			
	Indicated Indoor Dry Bulb Temperature				Indicated Indoor Dry Bulb Temperature			
	15.6	21.1	23.9	26.7	15.6	21.1	23.9	26.7
-27.8	20.4	17.8	16.8	15.8	5.5	6.0	6.2	6.5
-25.0	20.8	18.5	17.6	16.8	5.6	6.1	6.3	6.6
-22.2	21.4	19.4	18.7	18.0	5.7	6.2	6.5	6.7
-19.4	22.3	20.6	20.0	19.6	5.8	6.3	6.6	6.9
-16.7	23.4	22.1	21.6	21.3	5.9	6.5	6.7	7.0
-13.9	24.7	23.8	23.4	23.2	6.0	6.6	6.9	7.2
-11.1	26.4	25.7	25.5	25.3	6.2	6.7	7.0	7.4
-8.3	28.3	27.8	27.7	27.6	6.3	6.9	7.2	7.5
-5.6	30.5	30.2	30.1	30.1	6.5	7.0	7.4	7.7
-2.8	33.0	32.8	32.7	32.7	6.6	7.2	7.5	7.9
0.0	35.7	35.5	35.5	35.5	6.8	7.4	7.7	8.1
2.8	38.5	38.3	38.3	38.3	6.9	7.6	7.9	8.3
5.6	41.4	41.3	41.2	41.1	7.1	7.8	8.1	8.5
8.3	44.5	44.3	44.2	44.1	7.3	8.0	8.4	8.8
11.1	47.7	47.5	47.3	47.2	7.5	8.2	8.6	9.0
13.9	51.1	50.7	50.5	50.3	7.7	8.4	8.8	9.2
16.7	54.5	54.0	53.8	53.5	7.9	8.7	9.1	9.5
19.4	58.0	57.4	57.0	56.7	8.1	8.9	9.3	9.8
22.2	61.5	60.8	60.4	60.0	8.4	9.2	9.6	10.0

Correction Factors - Other Airflows* (Table Value)
 Correction Factor = Value at new airflow
 Airflow 4500 cfm 5500 cfm
 7645 m³/h 9344 m³/h

Heating Capacity x0.99 x1.01
 Compressor kW x1.02 x0.98

Values at ARI Rating Conditions of:
 70F (21.1C) and 47/43F (8.3/6.1C)(High Temp. Cond.)
 70F (21.1C) and 17/15F (-8.3/-9.4C)(Low Temp. Cond.)

Airflow = 5000 cfm (8494 m³/h)
 Heating Capacity (High Temp.) = 151,000 (44.27)
 Heating Capacity (Low Temp.) = 95,000 (27.67)
 Compressor Power (High Temp.) = 10.94 kW
 Compressor Power (Low Temp.) = 9.18 kW
 Coeff. Of Perf. (High Temp) = 3.2
 Coeff. Of Perf. (Low Temp) = 2.3
 Outdoor Fan Power = 1100 watts
 Indoor Fan Power = 1700 watts

Note:
 1. Rated with 25 feet of 1-3/8" suction and 1/2" liquid line."



Performance Data (System)

Table PD-12 — Gross Heating Capacities (MBh)
TWA200B Heat Pump with TWE200B Air Handler At 6675 CFM (I-P)

Outdoor Temperature (°F)	Heating Capacity (BTUH/1000) At				Total Power in Kilowatts At			
	Indicated Indoor Dry Bulb Temperature				Indicated Indoor Dry Bulb Temperature			
	60	70	75	80	60	70	75	80
-18	43.5	80.3	85.7	88.4	10.8	14.5	15.6	16.5
-13	68.9	87.1	91.0	93.0	12.3	14.8	15.8	16.7
-8	82.3	94.2	97.0	98.4	13.0	15.1	16.0	16.8
-3	93.2	101.6	103.6	104.5	13.4	15.3	16.2	17.1
2	103.5	109.4	110.8	111.3	13.8	15.6	16.4	17.3
7	113.7	117.8	118.6	118.8	14.1	15.8	16.7	17.6
12	124.2	126.8	127.2	127.1	14.5	16.1	17.0	17.9
17	135.0	136.4	136.5	136.1	14.8	16.4	17.3	18.2
22	146.2	146.7	146.5	146.0	15.1	16.7	17.6	18.5
27	157.9	157.6	157.2	156.6	15.4	17.1	18.0	18.9
32	170.2	169.3	168.8	168.1	15.7	17.4	18.4	19.4
37	182.4	181.2	180.5	179.8	16.0	17.8	18.8	19.8
42	195.1	193.5	192.7	192.0	16.4	18.2	19.2	20.3
47	208.4	206.5	205.7	205.0	16.7	18.6	19.7	20.8
52	222.4	220.3	219.4	218.7	17.2	19.1	20.2	21.3
57	236.9	234.6	233.6	232.9	17.6	19.6	20.7	21.9
62	251.7	249.2	248.2	247.4	18.1	20.1	21.2	22.4
67	266.7	264.0	262.9	262.1	18.5	20.6	21.8	23.0
72	282.3	279.4	278.2	277.2	19.1	21.2	22.4	23.7

Table PD-12 — Gross Heating Capacities (kW)
TWA200B Heat Pump with TWE200B Air Handler At 11340 m³/h (SI)

Outdoor Temperature (°C)	Heating Capacity (kW) At				Total Power in Kilowatts At			
	Indicated Indoor Dry Bulb Temperature				Indicated Indoor Dry Bulb Temperature			
	15.6	21.1	23.9	26.7	15.6	21.1	23.9	26.7
27.8	12.7	23.5	25.1	25.9	5.5	6.0	6.2	6.5
-25.0	20.2	25.5	26.6	27.2	5.6	6.1	6.3	6.6
-22.2	24.1	27.6	28.4	28.8	5.7	6.2	6.5	6.7
-19.4	27.3	29.7	30.3	30.6	5.8	6.3	6.6	6.9
-16.7	30.3	32.0	32.4	32.6	5.9	6.5	6.7	7.0
-13.9	33.3	34.5	34.7	34.8	6.0	6.6	6.9	7.2
-11.1	36.4	37.1	37.2	37.2	6.2	6.7	7.0	7.4
-8.3	39.5	39.9	40.0	39.9	6.3	6.9	7.2	7.5
-5.6	42.8	42.9	42.9	42.7	6.5	7.0	7.4	7.7
-2.8	46.2	46.2	46.0	45.9	6.6	7.2	7.5	7.9
0.0	49.8	49.6	49.4	49.2	6.8	7.4	7.7	8.1
2.8	53.4	53.0	52.8	52.6	6.9	7.6	7.9	8.3
5.6	57.1	56.7	56.4	56.2	7.1	7.8	8.1	8.5
8.3	61.0	60.5	60.2	60.0	7.3	8.0	8.4	8.8
11.1	65.1	64.5	64.3	64.0	7.5	8.2	8.6	9.0
13.9	69.4	68.7	68.4	68.2	7.7	8.4	8.8	9.2
16.7	73.7	73.0	72.7	72.4	7.9	8.7	9.1	9.5
19.4	78.1	77.3	77.0	76.7	8.1	8.9	9.3	9.8
22.2	82.7	81.8	81.5	81.2	8.4	9.2	9.6	10.0

Correction Factors - Other Airflows
 (Table Value x Correction Factor = Value at new airflow)

Airflow	6000 cfm	7325 cfm
	10193 m³/h	12444 m³/h
Heating Capacity	x0.99	x1.01
Compressor kW	x1.02	x0.98

Values at ARI Rating Conditions of:
 70F (21.1C) and 47/43F (8.3/6.1C)(High Temp. Cond.)
 70F (21.1C) and 17/15F (-8.3/-9.4C)(Low Temp. Cond.)

Airflow = 6675 cfm (11340 m³/h)
 Heating Capacity (High Temp.) = 206,000 (60.26)
 Heating Capacity (Low Temp.) = 135,000 (39.66)
 Compressor Power (High Temp) = 14.92 kW
 Compressor Power (Low Temp) = 12.62 kW
 Coeff. Of Perf. (High Temp) = 3.2
 Coeff. Of Perf. (Low Temp) = 2.4
 Outdoor Fan Power = 1,100 watts
 Indoor Fan Power = 2,290 watts

Note:
 1. Rated with 25 feet of 1-3/8" suction and 1/2" liquid line."



Performance Data (Air Handler)

Table PD-13 — Evaporator Fan Performance — TWEE050A (I-P)

CFM	External Static Pressure (Inches of Water Column)																					
	.10"		.20"		.30"		.40"		.50"		.60"		.70"		.80"		.90"		1.00"		1.10"	
	RPM	BHP	RPM	BHP	RPM	BHP	RPM	BHP	RPM	BHP	RPM	BHP	RPM	BHP	RPM	BHP	RPM	BHP	RPM	BHP	RPM	BHP
1400	—	—	—	—	646	0.37	698	0.42	751	0.47	803	0.52	856	0.56	908	0.61	941	0.65	973	0.68	1006	0.71
1500	—	—	607	0.36	661	0.40	713	0.45	764	0.50	816	0.54	867	0.59	919	0.64	952	0.67	984	0.71	—	—
1600	—	—	625	0.38	676	0.43	727	0.48	778	0.52	828	0.57	879	0.62	930	0.67	963	0.70	995	0.74	—	—
1700	601	0.35	648	0.40	696	0.44	744	0.49	792	0.54	841	0.59	889	0.64	937	0.69	971	0.73	1005	0.77	—	—
1800	625	0.36	671	0.41	716	0.46	762	0.51	807	0.56	853	0.61	898	0.66	944	0.71	979	0.76	—	—	—	—
1900	642	0.40	687	0.45	731	0.50	776	0.55	820	0.60	865	0.66	909	0.71	951	0.75	987	0.80	—	—	—	—
2000	659	0.44	703	0.49	745	0.54	790	0.60	833	0.65	877	0.70	920	0.75	957	0.80	994	0.84	—	—	—	—
2100	674	0.48	722	0.54	770	0.60	817	0.65	857	0.70	897	0.75	936	0.80	973	0.85	1009	0.89	—	—	—	—
0.75 HP Standard Motor and Standard Static Drive										1.0 HP Oversized Motor and High Static Drive												

Notes:

1. Performance based on a wet coil and 1 inch (25.4 mm) throwaway filters.
2. Tabulated brake horsepower is the motor shaft output required.
3. Factory setting of motor sheave is 1.5 turns open. Adjustments are made in 0.5 turn increments.

Table PD-13— Evaporator Fan Performance — TWEE050A (SI)

m ³ /hr	External Static Pressure (Pascal)																						
	25		50		75		100		125		150		174		199		224		249		274		
	RPM	kW	RPM	kW	RPM	kW	RPM	kW	RPM	kW	RPM	kW	RPM	kW	RPM	kW	RPM	kW	RPM	kW	RPM	kW	RPM
2379	—	—	—	—	646	0.28	698	0.31	751	0.35	803	0.39	856	0.42	908	0.45	941	0.48	973	0.51	1006	0.53	
2549	—	—	607	0.27	661	0.30	713	0.34	764	0.37	816	0.40	867	0.44	919	0.48	952	0.50	984	0.53	—	—	
2718	—	—	625	0.28	676	0.32	727	0.36	778	0.39	828	0.43	879	0.46	930	0.50	963	0.52	995	0.55	—	—	
2888	601	0.26	648	0.30	696	0.33	744	0.37	792	0.40	841	0.44	889	0.48	937	0.51	971	0.54	1005	0.57	—	—	
3058	625	0.27	671	0.31	716	0.34	762	0.38	807	0.42	853	0.45	898	0.49	944	0.53	979	0.57	—	—	—	—	
3228	642	0.30	687	0.34	731	0.37	776	0.41	820	0.45	865	0.49	909	0.53	951	0.56	987	0.60	—	—	—	—	
3398	659	0.33	703	0.37	745	0.40	790	0.45	833	0.48	877	0.52	920	0.56	957	0.60	994	0.63	—	—	—	—	
3568	674	0.36	722	0.40	770	0.45	817	0.48	857	0.52	897	0.56	936	0.60	973	0.63	1009	0.66	—	—	—	—	
0.56 kW Standard Motor and Standard Static Drive									0.75 kW Oversized Motor and High Static Drive														

Notes:

1. Performance based on a wet coil and 1 inch (25.4 mm) throwaway filters.
2. Tabulated brake horsepower is the motor shaft output required.
3. Factory setting of motor sheave is 1.5 turns open. Adjustments are made in 0.5 turn increments.

Table PD-14 — Blower Speeds — TWEE050A

Drive	Motor Drive Turns Open						
	6	5	4	3	2	1	0
Standard	N/A	590	639	688	737	786	835
High Static	N/A	713	772	832	891	951	1009

Performance Data

(Air Handler)

Table PD-15 — Evaporator Fan Performance TWE075A (I-P)

CFM	External Static Pressure (In. Of Water Column)																					
	0.10		0.20		0.30		0.40		0.50		0.60		0.70		0.80		0.90		1.00		1.10	
	RPM	BHP	RPM	BHP	RPM	BHP	RPM	BHP	RPM	BHP	RPM	BHP	RPM	BHP	RPM	BHP	RPM	BHP	RPM	BHP	RPM	BHP
2000	—	—	443	0.44	489	0.49	535	0.54	581	0.59	627	0.64	673	0.69	719	0.74	765	0.79	791	0.83	818	0.89
2125	—	—	453	0.46	499	0.52	546	0.57	592	0.63	638	0.68	684	0.74	730	0.79	771	0.85	798	0.90	825	0.96
2250	—	—	463	0.49	510	0.55	556	0.61	602	0.67	649	0.73	695	0.79	742	0.85	776	0.91	804	0.97	831	1.03
2375	—	—	473	0.51	520	0.57	567	0.64	613	0.70	660	0.77	706	0.83	753	0.90	782	0.97	810	1.03	838	1.10
2500	445	0.47	489	0.54	533	0.60	578	0.67	622	0.73	667	0.80	711	0.86	756	0.93	784	0.99	813	1.07	842	1.14
2625	464	0.50	506	0.57	548	0.63	589	0.69	631	0.76	672	0.82	714	0.88	757	0.95	786	1.01	815	1.09	844	1.17
2750	484	0.53	523	0.59	562	0.66	601	0.72	640	0.78	678	0.84	717	0.91	758	0.97	787	1.03	817	1.12	847	1.21
2875	504	0.56	540	0.62	576	0.68	612	0.74	648	0.81	684	0.87	720	0.93	759	0.99	789	1.05	819	1.15	850	1.24
3000	524	0.59	557	0.65	590	0.71	624	0.77	657	0.83	690	0.89	723	0.95	760	1.01	790	1.07	821	1.17	853	1.27
	1.0 HP Standard Motor and Low Static Drive							1.0 HP Standard Motor and Drive							1.5 HP Oversized Motor and High Static Drive							

Notes:

- Performance based on a wet coil and 1 inch (25.4 mm) throwaway filters.
- Tabulated brake horsepower is the motor shaft output required.
- Factory setting of motor sheave is 1.5 turns open. Adjustments are made in 0.5 turn increments.

Table PD-15— Continued

CFM	External Static Pressure (In. Of Water Column)									
	1.20		1.30		1.40		1.50		1.60	
	RPM	BHP	RPM	BHP	RPM	BHP	RPM	BHP	RPM	BHP
2000	844	0.96	871	1.02	897	1.09	924	1.15	950	1.21
2125	852	1.03	879	1.09	906	1.16	933	1.22	—	—
2250	859	1.10	886	1.17	914	1.23	942	1.30	—	—
2375	866	1.17	894	1.24	922	1.30	950	1.37	—	—
2500	870	1.21	899	1.29	928	1.36	—	—	—	—
2625	874	1.25	903	1.33	932	1.42	—	—	—	—
2750	877	1.29	907	1.38	937	1.47	—	—	—	—
2875	880	1.33	911	1.43	942	1.52	—	—	—	—
3000	884	1.37	915	1.48	946	1.58	—	—	—	—
	1.5 HP Oversized Motor and High Static Drive									

1.0 HP Standard Motor and Drive

Table PD-15 — Evaporator Fan Performance TWE075A (SI)

m³/hr	External Static Pressure (Pascal)																					
	25		50		75		100		125		150		174		199		224		249		274	
	RPM	kW	RPM	kW	RPM	kW	RPM	kW	RPM	kW	RPM	kW	RPM	kW	RPM	kW	RPM	kW	RPM	kW	RPM	kW
3338	—	—	443	0.33	489	0.37	535	0.4	581	0.44	627	0.48	673	0.51	719	0.55	765	0.59	791	0.62	818	0.66
3547	—	—	453	0.34	499	0.39	546	0.43	592	0.47	638	0.51	684	0.55	730	0.59	771	0.63	798	0.67	825	0.72
3755	—	—	463	0.37	510	0.41	556	0.45	602	0.5	649	0.54	695	0.59	742	0.63	776	0.68	804	0.72	831	0.77
3964	—	—	473	0.38	520	0.43	567	0.48	613	0.52	660	0.57	706	0.62	753	0.67	782	0.72	810	0.77	838	0.82
4173	445	0.35	489	0.4	533	0.45	578	0.5	622	0.54	667	0.6	711	0.64	756	0.69	784	0.74	813	0.8	842	0.85
4381	464	0.37	506	0.43	548	0.47	589	0.51	631	0.57	672	0.61	714	0.66	757	0.71	786	0.75	815	0.81	844	0.87
4590	484	0.4	523	0.44	562	0.49	601	0.54	640	0.58	678	0.63	717	0.68	758	0.72	787	0.77	817	0.84	847	0.9
4798	504	0.42	540	0.46	576	0.51	612	0.55	648	0.6	684	0.65	720	0.69	759	0.74	789	0.78	819	0.86	850	0.92
5007	524	0.44	557	0.48	590	0.53	624	0.57	657	0.62	690	0.66	723	0.71	760	0.75	790	0.8	821	0.87	853	0.95
	.75 kW Standard Motor and Low Static Drive							.75 kW Standard Motor and Drive							1.12 kW Oversized Motor and High Static Drive							

Notes:

- Performance based on a wet coil and 1 inch (25.4 mm) throwaway filters.
- Tabulated brake horsepower is the motor shaft output required.
- Factory setting of motor sheave is 1.5 turns open. Adjustments are made in 0.5 turn increments.

Table PD-15 — Continued

m³/hr	External Static Pressure (Pascal)									
	299		324		349		374		398	
	RPM	kW	RPM	kW	RPM	kW	RPM	kW	RPM	kW
3338	844	0.72	871	0.76	897	0.81	924	0.86	950	0.9
3547	852	0.77	879	0.81	906	0.87	933	0.91	—	—
3755	859	0.82	886	0.87	914	0.92	942	0.97	—	—
3964	866	0.87	894	0.92	922	0.97	950	1.02	—	—
4173	870	0.9	899	0.96	928	1.01	—	—	—	—
4381	874	0.93	903	0.99	932	1.06	—	—	—	—
4590	877	0.96	907	1.03	937	1.1	—	—	—	—
4798	880	0.99	911	1.07	942	1.13	—	—	—	—
5007	884	1.02	915	1.1	946	1.18	—	—	—	—
	1.12 kW Oversized Motor and High Static Drive									

.75 kW Standard Motor and Drive

Table PD-16 — Blower Speeds — TWE075A

Drive	Motor Drive Turns Open						
	6	5	4	3	2	1	0
Standard	N/A	600	650	700	750	800	850
Low Static	N/A	428	464	499	535	571	606
High Static	N/A	700	750	800	850	900	950



Performance Data (Air Handler)

Table PD-17 — Evaporator Fan Performance TWE100A, TWE100B (I-P)

CFM	External Static Pressure (In. Of Water Column)																							
	0.10		0.20		0.30		0.40		0.50		0.60		0.70		0.80		0.90		1.00		1.20			
	RPM	BHP	RPM	BHP	RPM	BHP	RPM	BHP	RPM	BHP	RPM	BHP	RPM	BHP	RPM	BHP	RPM	BHP	RPM	BHP	RPM	BHP	RPM	BHP
1.5 HP Standard Motor and Low Static Drive																								
2600	460	0.32	493	0.39	527	0.47	565	0.55	603	0.63	641	0.71	679	0.79	717	0.87	744	0.94	772	1.01	826	1.16		
2775	473	0.37	506	0.45	540	0.53	576	0.61	613	0.69	649	0.77	686	0.85	723	0.93	748	1.00	775	1.07	830	1.20		
2950	487	0.43	519	0.50	552	0.58	587	0.67	623	0.75	658	0.83	693	0.91	728	0.99	751	1.06	779	1.12	833	1.25		
3125	501	0.49	532	0.56	565	0.64	599	0.72	632	0.81	666	0.89	700	0.97	734	1.05	755	1.11	783	1.18	737	1.30		
3300	520	0.58	548	0.65	581	0.73	613	0.81	644	0.89	677	0.98	710	1.06	740	1.13	759	1.19	787	1.25	841	1.37		
3475	541	0.69	568	0.76	600	0.84	631	0.93	658	1.00	691	1.08	721	1.16	746	1.21	764	1.28	793	1.34	846	1.48		
3650	562	0.82	588	0.88	618	0.97	648	1.05	671	1.11	703	1.19	732	1.27	753	1.31	772	1.38	801	1.45	853	1.59		
3825	582	0.96	608	1.03	637	1.11	666	1.20	685	1.26	711	1.31	739	1.38	763	1.44	787	1.51	815	1.58	862	1.74		
4000	602	1.11	628	1.17	656	1.26	683	1.35	698	1.40	720	1.43	747	1.50	773	1.58	801	1.64	829	1.71	872	1.89		
1.5 HP Standard Motor and Drive																	2.0 HP Oversized Motor and High Static Drive							

Notes:

- Performance based on a wet coil and 1 inch (25.4 mm) throwaway filters.
- Tabulated brake horsepower is the motor shaft output required.
- Factory setting of motor sheave is 1.5 turns open. Adjustments are made in 0.5 turn increments.
- Low Static Drive must be field supplied.

Table PD-17— Continued

CFM	External Static Pressure (In. Of Water Column)			
	1.40		1.60	
	RPM	BHP	RPM	BHP
2.0 HP Oversized Motor and High Static Drive				
2600	881	1.30	936	1.45
2775	884	1.36	938	1.51
2960	886	1.41	939	1.57
3125	889	1.47	941	1.64
3300	892	1.54	945	1.73
3475	897	1.63	950	1.85
3650	902	1.73	955	1.99
3825	912	1.89	960	2.18
4000	922	2.04	965	2.30

Table PD-17— Evaporator Fan Performance TWE0100A, TWE100B (SI)

m³/hr	External Static Pressure (Pascal)																							
	25		50		75		100		125		150		174		199		224		249		299			
	RPM	kW	RPM	kW	RPM	kW	RPM	kW	RPM	kW	RPM	kW	RPM	kW	RPM	kW	RPM	kW	RPM	kW	RPM	kW	RPM	kW
1.12 kW Standard Motor and Low Static Drive																								
4417	460	0.24	493	0.29	527	0.35	565	0.41	603	0.47	641	0.53	679	0.59	717	0.65	744	0.7	772	0.75	826	0.87		
4715	473	0.28	506	0.34	540	0.4	576	0.45	613	0.51	649	0.57	686	0.63	723	0.69	748	0.75	775	0.8	830	0.89		
5012	487	0.32	519	0.37	552	0.43	587	0.5	623	0.56	658	0.62	693	0.68	728	0.74	751	0.79	779	0.84	833	0.93		
5309	501	0.37	532	0.42	565	0.48	599	0.54	632	0.6	666	0.66	700	0.72	734	0.78	755	0.83	783	0.88	737	0.97		
5607	520	0.43	548	0.48	581	0.54	613	0.6	644	0.66	677	0.73	710	0.79	740	0.84	759	0.89	787	0.93	841	1.02		
5904	541	0.51	568	0.57	600	0.63	631	0.69	658	0.75	691	0.8	721	0.87	746	0.9	764	0.95	793	1	846	1.1		
6201	562	0.61	588	0.66	618	0.72	648	0.78	671	0.83	703	0.89	732	0.95	753	0.98	772	1.03	801	1.08	853	1.19		
6499	582	0.72	608	0.77	637	0.83	666	0.89	685	0.94	711	0.98	739	1.03	763	1.07	787	1.13	815	1.18	862	1.3		
6796	602	0.83	628	0.87	656	0.94	683	1.01	698	1.04	720	1.07	747	1.12	773	1.18	801	1.22	829	1.28	872	1.41		
1.12 kW Standard Motor and Drive																	1.49 kW Oversized Motor and High Static Drive							

Notes:

- Performance based on a wet coil and 1 inch (25.4 mm) throwaway filters.
- Tabulated brake horsepower is the motor shaft output required.
- Factory setting of motor sheave is 3.0 turns open. Adjustments are made in 0.5 turn increments.
- Low Static Drive must be field supplied.

Table PD-17— Continued

m³/hr	External Static Pressure (Pascal)			
	349		398	
	RPM	kW	RPM	kW
1.49 kW Oversized Motor and High Static Drive				
4417	881	0.97	936	1.08
4715	884	1.01	938	1.13
5012	886	1.05	939	1.17
5309	889	1.1	941	1.22
5607	892	1.15	945	1.29
5904	897	1.22	950	1.38
6201	902	1.29	955	1.48
6499	912	1.41	960	1.63
6796	922	1.52	965	1.72

Table PD - 18 — Blower Speeds — TWE100A, TWE100B

Drive	Motor Sheave Turns Open						
	6	5	4	3	2	1	0
Standard	N/A	587	629	671	713	755	796
Low Static	N/A	453	485	518	550	583	615
High Static	N/A	606	641	677	713	748	784
High Static II	N/A	745	789	833	877	920	965



Performance Data

(Air Handler)

Table PD-19 — Evaporator Fan Performance — TWE155B (I-P)

CFM	External Static Pressure (Inches of Water Column)																									
	.10"		.20"		.30"		.40"		.50"		.60"		.70"		.80"		.90"		1.00"		1.20"		1.40"			
	RPM	BHP	RPM	BHP	RPM	BHP	RPM	BHP	RPM	BHP	RPM	BHP	RPM	BHP	RPM	BHP	RPM	BHP	RPM	BHP	RPM	BHP	RPM	BHP	RPM	BHP
	2.0HP Standard Motor and Drive												3.0HP Oversized Motor and High Static Drive													
4000	628	1.34	653	1.38	678	1.43	692	1.48	708	1.52	723	1.57	738	1.60	749	1.61	759	1.62	795	1.66	851	1.85	907	2.03		
4250	633	1.37	658	1.41	683	1.46	697	1.51	713	1.55	728	1.60	743	1.62	751	1.63	770	1.64	806	1.71	862	1.90	918	2.11		
4500	637	1.40	662	1.44	687	1.49	701	1.53	717	1.58	732	1.63	747	1.64	754	1.65	782	1.67	817	1.76	873	1.96	929	2.19		
4750	641	1.42	666	1.50	691	1.53	705	1.61	721	1.63	736	1.65	751	1.66	765	1.67	793	1.72	828	1.81	884	2.01	940	2.27		
5000	645	1.44	670	1.52	695	1.56	710	1.65	725	1.67	739	1.68	758	1.70	777	1.74	806	1.81	839	1.91	896	2.13	—	—		
5260	650	1.46	675	1.53	700	1.59	716	1.67	728	1.70	741	1.73	765	1.75	790	1.82	819	1.92	849	2.03	907	2.28	—	—		
5500	652	1.47	678	1.55	703	1.63	721	1.71	734	1.75	747	1.78	775	1.83	804	1.92	832	2.03	861	2.15	920	2.44	—	—		
5750	653	1.48	680	1.57	706	1.68	726	1.76	743	1.81	761	1.86	789	1.94	817	2.04	846	2.16	875	2.29	935	2.61	—	—		
6000	655	1.49	681	1.59	709	1.74	731	1.80	752	1.87	774	1.94	803	2.05	831	2.17	860	2.29	889	2.44	950	2.78	—	—		

Notes:

1. Performance based on a wet coil and 2 inch (51 mm) throwaway filters.
2. Tabulated brake horsepower is the motor shaft output required.
3. Factory setting of motor sheave is 1.5 turns open. Adjustments are made in 0.5 turn increments.

Table PD-19 — Evaporator Fan Performance TWE155B (SI)

m ³ /hr	External Static Pressure (Pascal)																									
	25		50		75		100		125		150		174		199		224		249		299		349			
	RPM	kW	RPM	kW	RPM	kW	RPM	kW	RPM	kW	RPM	kW	RPM	kW	RPM	kW	RPM	kW	RPM	kW	RPM	kW	RPM	kW	RPM	kW
	1.49 kW Standard Motor and Drive												2.24 kW Oversized Motor and High Static Drive													
6796	628	1	653	1.03	678	1.07	692	1.1	708	1.13	723	1.17	738	1.19	749	1.2	759	1.21	795	1.24	851	1.38	907	1.51		
7221	633	1.02	658	1.05	683	1.09	697	1.13	713	1.16	728	1.19	743	1.21	751	1.22	770	1.22	806	1.28	862	1.42	918	1.57		
7646	637	1.04	662	1.07	687	1.11	701	1.14	717	1.18	732	1.22	747	1.23	754	1.23	782	1.25	817	1.31	873	1.46	929	1.63		
8070	641	1.06	666	1.12	691	1.14	705	1.2	721	1.22	736	1.23	751	1.24	765	1.25	793	1.28	828	1.35	884	1.5	940	1.69		
8495	645	1.07	670	1.13	695	1.16	710	1.23	725	1.25	739	1.25	758	1.27	777	1.3	806	1.35	839	1.42	896	1.59	—	—		
8937	650	1.09	675	1.14	700	1.19	716	1.25	728	1.27	741	1.29	765	1.3	790	1.36	819	1.43	849	1.51	907	1.7	—	—		
9345	652	1.1	678	1.16	703	1.22	721	1.28	734	1.3	747	1.33	775	1.36	804	1.43	832	1.51	861	1.6	920	1.82	—	—		
9769	653	1.1	680	1.17	706	1.25	726	1.31	743	1.3	761	1.39	789	1.45	817	1.52	846	1.61	875	1.71	935	1.95	—	—		
10194	655	1.11	681	1.19	709	1.3	731	1.34	752	1.35	774	1.45	803	1.53	831	1.62	860	1.71	889	1.82	950	2.07	—	—		

Notes:

1. Performance based on a wet coil and 2 inch (51 mm) throwaway filters.
2. Tabulated brake horsepower is the motor shaft output required.
3. Factory setting of motor sheave is 1.5 turns open. Adjustments are made in 0.5 turn increments.

Table PD-20— Blower Speeds — TWE155B

Drive	Motor Sheave Turns Open						
	6	5	4	3	2	1	0
Standard	619	648	677	705	734	763	N/A
High Static	777	806	835	863	892	921	950



Performance Data (Air Handler)

Table PD-21— Evaporator Fan Performance TWE200B (I-P)

CFM	External Static Pressure (In. Of Water Column)																							
	0.10		0.20		0.30		0.40		0.50		0.60		0.70		0.80		0.90		1.00		1.20		140	
	RPM	BHP	RPM	BHP	RPM	BHP	RPM	BHP	RPM	BHP	RPM	BHP	RPM	BHP	RPM	BHP	RPM	BHP	RPM	BHP	RPM	BHP	RPM	BHP
5200	—	—	461	0.74	503	0.91	545	1.07	587	1.03	619	1.17	685	1.40	723	1.59	750	1.74	777	1.89	851	2.19	898	2.39
5525	—	—	479	0.88	521	1.04	563	1.21	605	1.21	640	1.35	701	1.58	739	1.77	766	1.92	793	2.07	859	2.37	906	2.60
5850	—	—	497	1.01	539	1.18	581	1.34	623	1.39	661	1.53	717	1.76	755	1.95	782	2.10	809	2.25	868	2.55	915	2.81
6175	473	0.99	515	1.15	557	1.31	599	1.48	641	1.57	682	1.71	732	1.94	769	2.12	796	2.27	823	2.43	877	2.73	924	3.02
6500	492	1.12	534	1.28	576	1.45	618	1.61	660	1.75	702	1.90	748	2.12	784	2.30	811	2.45	838	2.60	886	2.91	933	3.22
6825	510	1.25	552	1.42	594	1.59	636	1.75	678	1.91	723	2.10	763	2.30	794	2.47	820	2.62	846	2.77	894	3.09	941	3.42
7150	528	1.38	570	1.56	612	1.73	654	1.90	697	2.07	744	2.30	779	2.49	804	2.64	830	2.78	855	2.94	903	3.26	950	3.62
7475	550	1.61	594	1.77	640	1.92	683	2.08	721	2.29	760	2.50	790	2.67	815	2.81	840	2.96	865	3.11	914	3.47	959	3.85
7800	572	1.83	618	1.97	668	2.10	712	2.27	746	2.52	776	2.69	802	2.84	826	2.99	851	3.13	876	3.27	926	3.67	969	4.08
3.0HP Standard Motor and Low Static Drive			3 HP Standard Motor and Low Static Drive System II					3 HP Standard Motor and Standard Drive System					5 HP Oversized Motor and High Static Drive System											

Notes:

- Performance based on a wet coil and 2 inch (51 mm) throwaway filters.
- Tabulated brake horsepower is the motor shaft output required.
- Factory setting of motor sheave is 1.5 turns open. Adjustments are made in 0.5 turn increments.
- Low static drive components referencing this note are field supplied.

Table PD-21— Continued

External Static Pressure (In. Of Water Column)

CFM	1.60		1.80	
	RPM	BHP	RPM	BHP
5 HP Oversized Motor and High Static Drive System				
5200	944	2.75	989	3.12
5525	952	2.96	997	3.33
5850	961	3.17	1006	3.54
5175	970	3.38	1015	3.75
8500	978	3.59	1023	3.96
8825	986	3.80	—	—
7150	994	4.01	—	—
7475	1003	4.25	—	—
7800	1012	4.50	—	—

Table PD-21— Evaporator Fan Performance TWE200B (SI)

m³/hr	External Static Pressure (Pascal)																							
	25		50		75		100		125		150		174		199		224		249		299		349	
	RPM	kW	RPM	kW	RPM	kW	RPM	kW	RPM	kW	RPM	kW	RPM	kW	RPM	kW	RPM	kW	RPM	kW	RPM	kW	RPM	kW
8835	—	—	461	0.55	503	0.68	545	0.8	587	0.77	619	0.87	685	1.04	723	1.19	750	1.3	777	1.41	851	1.63	898	1.78
9387	—	—	479	0.66	521	0.78	563	0.9	605	0.9	640	1.01	701	1.18	739	1.32	766	1.43	793	1.54	859	1.77	906	1.94
9939	—	—	497	0.75	539	0.88	581	1	623	1.04	661	1.14	717	1.31	755	1.45	782	1.57	809	1.68	868	1.9	915	2.1
10491	473	0.74	515	0.86	557	0.98	599	1.1	641	1.17	682	1.28	732	1.45	769	1.58	796	1.69	823	1.81	877	2.04	924	2.52
11044	492	0.84	534	0.95	576	1.08	618	1.2	660	1.3	702	1.42	748	1.58	784	1.72	811	1.83	838	1.94	886	2.17	933	2.4
11596	510	0.93	552	1.06	594	1.19	636	1.3	678	1.42	723	1.57	763	1.72	794	1.84	820	1.95	846	2.07	894	2.3	941	2.55
12148	528	1.03	570	1.16	612	1.29	654	1.42	697	1.54	744	1.72	779	1.86	804	1.97	830	2.07	855	2.19	903	2.43	950	2.7
12700	550	1.2	594	1.32	640	1.43	683	1.55	721	1.71	760	1.87	790	1.99	815	2.1	840	2.21	865	2.32	914	2.59	959	2.87
13252	572	1.36	618	1.47	668	1.57	712	1.69	746	1.88	776	2.01	802	2.12	826	2.23	851	2.33	876	2.44	926	2.74	969	3.04
2.24 kW Standard Motor and Low Static Drive System			2.24 kW Standard Motor and Low Static Drive System II					2.24 kW Standard Motor and Standard Drive System					3.73 kW Oversized Motor and High Static Drive System											

Notes:

- Performance based on a wet coil and 2 inch (51 mm) throwaway filters.
- Tabulated brake horsepower is the motor shaft output required.
- Factory setting of motor sheave is 1.5 turns open. Adjustments are made in 0.5 turn increments.
- Low static drive components referencing this note are field supplied.

Table PD-21— Continued

External Static Pressure (Pascal)

m³/hr	398		448	
	RPM	kW	RPM	kW
3.73 kW Oversized Motor and High Static Drive System				
8835	944	2.05	989	2.33
9387	952	2.21	997	2.48
9939	961	2.36	1006	2.64
10491	970	2.52	1015	2.8
11044	978	2.68	1023	2.95
11596	986	2.83	—	—
12148	994	2.99	—	—
12700	1003	3.17	—	—
13252	1012	3.36	—	—

Table PD-22 — Blower Speeds — TWE200B

Drive	Motor Sheave Turns Open						
	6	5	4	3	2	1	0
Standard	706	732	758	784	811	837	863
Low Static I	457	478	500	521	542	563	585
Low Static II	574	595	617	638	659	680	702
High Static	N/A	821	862	903	945	986	1027



Performance Data

Table PD-23— Discharge Plenum And Grille Assembly Throw Distance — Air Handler

Unit			Louver Angle Deflection Position			
Model No.	CFM	m ³ /h	Straight	20, ft (m)	40, ft (m)	55, ft (m)
TWE050	1400	2378	38 (11.6)	24 (7.3)	22 (6.7)	18 (5.5)
	1600	2718	42 (12.8)	31 (9.4)	26 (7.9)	20 (6.1)
	1800	3058	46 (14.0)	37 (11.3)	29 (8.8)	22 (6.7)
	2000	3398	48 (14.6)	43 (13.1)	33 (10.1)	24 (7.3)
	2200	3737	51 (15.5)	50 (15.2)	36 (11.0)	25 (7.6)
	2100	3568	49 (14.9)	38 (11.6)	31 (9.4)	27 (8.2)
TWE075	2400	4077	52 (15.9)	43 (13.1)	35 (10.7)	29 (8.8)
	2700	4587	55 (16.8)	48 (14.6)	38 (11.6)	31 (9.4)
	3000	5097	58 (17.7)	53 (16.2)	42 (12.8)	32 (9.8)
	3200	5436	56 (17.1)	46 (14.0)	38 (11.6)	30 (9.1)
	3600	6116	62 (18.9)	51 (15.5)	42 (12.8)	33 (10.1)
	TWE100	4000	6795	66 (20.1)	57 (17.4)	47 (14.3)
4400		7475	71 (21.6)	62 (18.9)	52 (15.9)	38 (11.6)
4800		8154	76 (23.2)	67 (20.4)	56 (17.1)	42 (12.8)
4300		7305	42 (12.8)	32 (9.8)	29 (8.8)	21 (6.4)
4900		8324	47 (14.3)	38 (11.6)	32 (9.8)	25 (7.6)
TWE155		5400	9174	52 (15.9)	44 (13.4)	37 (11.3)
	5600	9514	50 (15.2)	40 (12.2)	33 (10.1)	27 (8.2)
	6000	10193	57 (17.4)	49 (14.9)	41 (12.5)	32 (9.8)
	6400	10873	56 (17.1)	46 (14.0)	38 (11.6)	30 (9.1)
TWE200	7200	12232	62 (18.9)	51 (15.5)	42 (12.8)	33 (10.1)
	8000	13591	66 (20.1)	57 (17.4)	47 (14.3)	35 (10.7)

Throw distance values are based on a terminal velocity of 75 FPM (0.38 m/s).

Throw distance values at other terminal velocities may be established by multiplying throw distances in table above by throw factor:

Terminal Velocity		Throw Factor
50 fpm (.25 m/s)	x	1.50
100 fpm (.51 m/s)	x	.75
150 fpm (.76 m/s)	x	.50

PD-24 — Static Pressure Drop Through Accessories — Air Handler

Unit			Discharge							
Model No.	CFM	m ³ /h	Return Grille		Plenum and Grille ²		Electric Heaters (kW)			
			In. wc ¹	Pascal	In. wc ¹	Pascal	3.5-7	10-14	17-24	35
TWE050A	1400	2378	.09	(22.4)	.16	(39.8)	.06	.06	.12	—
	1600	2718	.12	(29.9)	.21	(52.3)	.08	.08	.14	—
	2000	3398	.18	(44.8)	.33	(82.2)	.13	.13	.19	—
	2100	3568	.05	(12.5)	.19	(47.3)	.02	.03	.05	.08
TWE075A	2400	4077	.08	(19.9)	.27	(67.2)	.03	.06	.08	.12
	3000	5097	.13	(32.4)	.40	(99.6)	.06	.12	.17	.23
TWE100A	2800	4757	.04	(10.0)	.34	(84.7)	.03	.04	.14	.20
TWE100B	3200	5436	.07	(17.4)	.43	(107.1)	.06	.13	.19	.26
	4300	7305	.07	(17.4)	.18	(44.8)	.02	.02	.04	.05
TWE155B	4800	8154	.09	(22.4)	.23	(57.3)	.03	.03	.06	.08
	5600	9514	.07	(17.4)	.32	(79.7)	.04	.04	.10	.15
	6000	10193	.15	(37.4)	.34	(84.7)	.06	.06	.12	.17
TWE200B	6400	10873	.11	(27.4)	.43	(107.1)	.06	.06	.13	.19
	8000	13591	.17	(42.3)	.66	(164.3)	.10	.10	.20	.30

1. Return air filter ESP included in Fan Performance Table data.

2. At louver opening angle of 42°F (5.5°C). For ESP at other angle openings, see accessory Installer's Guide.

Throw distance values are based on a terminal velocity of 75 fpm (0.38 m/s).

Throw distance values at other terminal velocities may be established by multiplying throw distances in table above by throw factor:

Terminal Velocity		Throw Factor
50 fpm (.25 m/s)	x	1.50
100 fpm (.51 m/s)	x	.75
150 fpm (.76 m/s)	x	.50



Performance Data

Table PD-25 — Auxiliary Electric Heat Capacity — Air Handler

Unit Model No.	Total kW	No. of Stages	Stage 1		Stage 2		Total			
			kW Input	Btu Output	kW Input	Btu Output	kW Output	Btu Output		
TWE050, 075, 100	3.47	1	3.47	11,851	3.47	—	—	11,851	3.47	
	6.92	1	9.92	23,606	6.92	—	—	23,606	6.92	
	10.39	1	10.39	35,457	10.39	—	—	35,457	10.39	
	17.31	2	10.39	35,457	10.39	6.92	23,606	6.92	59,063	17.31
TWE075, 100A, 100	24.22	2	13.83	47,213	13.83	10.39	35,457	10.39	82,670	24.22
TWE155, 200	6.94	1	6.94	23,701	6.94	—	—	—	23,701	6.94
	13.83	1	13.83	47,213	13.83	—	—	—	47,213	13.83
	20.78	2	13.83	47,213	13.83	6.94	23,701	6.94	70,915	20.78
	34.62	2	20.78	70,915	20.78	13.84	47,213	13.89	118,128	34.61

*Heaters are rated at 400v. For other than rated voltage,
 Capacity = $\left(\frac{\text{Voltage}}{\text{Rated Voltage}}\right)^2 \times \text{Rated Capacity}$ and kW = $\left(\frac{\text{Voltage}}{\text{Rated Voltage}}\right)^2 \times \text{Rated kW}$.

Electrical Data

Table ED-1— Electrical Characteristics — Motors — Air Handler

Unit Model No.	Standard Fan Motor					Oversized Fan Motor		
	Volts	Phase	Amps		Phase	Amps		
			FLA	LRA		FLA	LRA	
TWE050	380/415	3	1.4	8.2	3	1.8	21.6	
TWE075	380/415	3	3.2	19.7	3	4.0	25.5	
TWE100	380/415	3	3.6	25.5	3	5.3	37.5	
TWE155	380/415	3	4.6	37.5	3	6.9	39.2	
TWE200	380/415	3	7.6	39.2	3	9.0	65.1	

Table ED-2 — Unit Wiring — Air Handler

Unit Model No.	Unit Operating Voltage Range	Minimum Circuit Ampacity	Maximum Fuse Size or Maximum Circuit Breaker
TWE050	380/415	2	15
TWE075	380/415	4	15
TWE100	380/415	5	15
TWE155	380/415	6	15
TWE200	380/415	10	15

Table ED-3— Electrical Characteristics — Motors — 50 Cycle — Heat Pumps

Unit Model No.	Compressor Motor					Condenser Fan Motor				
	No.	Volts	Phase	Amps		No.	Volts	Phase	Amps	
				RLA (Ea.)	LRA (Ea.)				FLA (Ea.)	LRA (Ea.)
TWA075AD	1	380/415	3	8.8	90.0	1	380/415	1	1.6	3.7
TWA100AD	1	380/415	3	14.9	118.0	1	380/415	1	2.7	7.0
TWA155BD	2	380/415	3	11.2	94.8	2	380/415	1	1.6	3.7
TWA200BD	2	380/415	3	14.9	118.0	2	380/415	1	2.7	7.0

Table ED-4 — Unit Wiring — Heat Pumps

Unit Model No.	Unit Operating Voltage Range	Minimum Circuit Ampacity	Maximum Fuse Size or Maximum Circuit Breaker
TWA075	380/415	12.6	50
TWA100	380/415	21.3	35
TWA155	380/415	28.4	35
TWA200	380/415	38.9	50



Electrical Data

Table ED-5— Unit Wiring With Electric Heat (Single Point Connection) — Air Handlers

Heater Model No.	Heater kW Rating ¹	To Use with Unit	Control Stages	Minimum Circuit Ampacity ²	Maximum Fuse Breaker Size ²
BAYHTRL405A	3.47		1	9	15
BAYHTRL410A	6.92	TWE050AD	1	17	20
BAYHTRL415A	10.39		1	24	25
BAYHTRL425A	17.31		2	39	40
BAYHTRL405A	3.47		1	11	15
BAYHTRL410A	6.92		1	18	20
BAYHTRL415A	10.39	TWE075AD	1	26	30
BAYHTRL425A	17.31		2	41	45
BAYHTRL435A	24.22		2	56	60
BAYHTRL405A	3.47		1	12	15
BAYHTRL410A	6.92		1	19	25
BAYHTRL415A	10.39	TWE100AD, TWE100BD	1	27	30
BAYHTRL425A	20.78		2	42	45
BAYHTRL435A	24.22		2	57	60
BAYHTRM410A	6.94		1	21	30
BAYHTRM420A	13.83	TWE155BD	1	36	40
BAYHTRM430A	20.78		2	51	60
BAYHTRM450A	34.62		2	81	90
BAYHTRM410A	6.94		1	25	40
BAYHTRM420A	13.83	TWE200BD	1	40	50
BAYHTRM430A	20.78		2	55	60
BAYHTRM450A	34.62		2	85	90

1. kW ratings are at 400v for 3 phase, 400v air handlers

For other than rated voltage, ampacity = $\left(\frac{\text{Voltage}}{\text{Rated Voltage}}\right)^2 \times \text{Rated Capacity}$ and kW = $\left(\frac{\text{Voltage}}{\text{Rated Voltage}}\right)^2 \times \text{Rated kW}$.

2. Any power supply and circuits must be wired and protected in accordance with local codes.

3. Field wire must be rated at least 75°C.

4. Field wire must be rated at least 90°C.

Jobsite Connections

Wiring shown with dashed lines is to be furnished and installed by the customer. All customer-supplied wiring must be copper only and must conform to NEC and local electrical codes. Codes may require line of sight between disconnect switch and unit.

NOTE:

1. When electric heater accessory is used single point power entry or dual point power entry is field optional. Single point power entry option is through electric heater only.

TWA050/TWE050

Field Wiring:

- A — 3 power wires. Line voltage.
- B — 3 power wires. Line voltage.
- C — Heat pump thermostat: 6 wires, 24 volts.
— Electric heat: add 2 additional wires, 24 volts.
- D — 2 wires, 24 volts.
— Outdoor thermostat: add 1 additional wire per ODT, 24 volts.
— Electric heat: add 1 additional wire, 24 volts.

(2) TWA050/TWE100B

Field Wiring:

- A — 3 power wires. Line voltage.
- B — 3 power wires. Line voltage.
- C — Heat pump thermostat: 7 wires, 24 volts Electric Heat: add 2 additional wires, 24 volts.
- D — 5 wires, 24 volts to outdoor section "A" 2 wires, 24 volts to outdoor section "B" 2 wires, 24 volts between outdoor sections "A" "B"
— Electric heat: add 1 additional wire, 24 volts.
— Outdoor thermostat: add 1 additional wire, 24 volt.

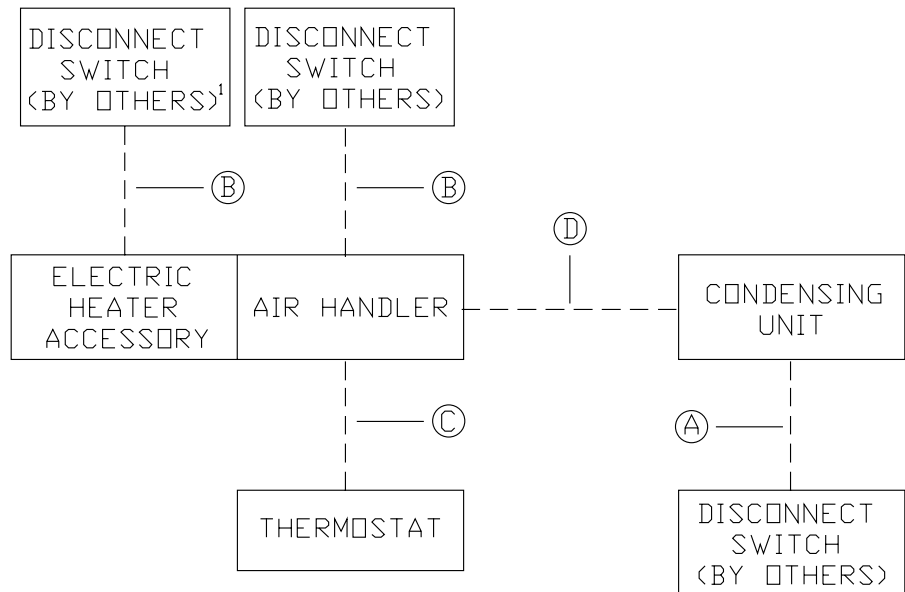

**TWA075A/TWE075A;
TWA100A/TWE100A**

Field Wiring:

- A — 3 power wires, line voltage.
- B — 3 power wires, line voltage.
- C — Heat pump thermostat: 6 wires, 24 volts.
— Electric heat: add 2 additional wires, 24 volts.
- D — 6 wires, 24 volts.
— Outdoor thermostat: add 1 additional wire, 24 volts.
— Electric heat: add 1 additional wire, 24 volts.

**(2) TWA075A/TWE155B;
(2) TWA100A/TWE200B**

Field Wiring:

- A — 3 power wires, line voltage.
- B — 3 power wires, line voltage.
- C — Heat pump thermostat: 7 wires, 24 volts.
— Electric heat: add 2 additional wires, 24 volts.

- D — 9 wires, 24 volts.
— Electric heat: add 4 additional wires, 24 volts.
— Outdoor thermostat: add 3 additional wires, 24 volts.

**TWA155B/TWE155B;
TWA200B/TWE200B**

Field Wiring:

- A — 3 power wires, line voltage.
- B — 3 power wires, line voltage.
- C — Heat pump thermostat: 7 wires, 24 volts.
— Electric heat: add 2 additional wires, 24 volts.
- D — 7 wires, 24 volts.
— Electric heat: add 4 additional wires, 24 volts.
— Outdoor thermostat: add 1 additional wire, 24 volts.

Typical Wiring (Heat Pump)

Heat Pump — Single Compressor

Typical unit wiring diagram. For specific wiring, see individual Service Facts.

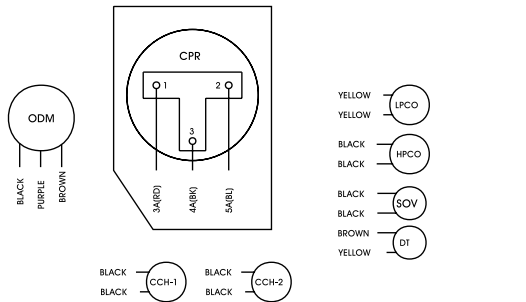
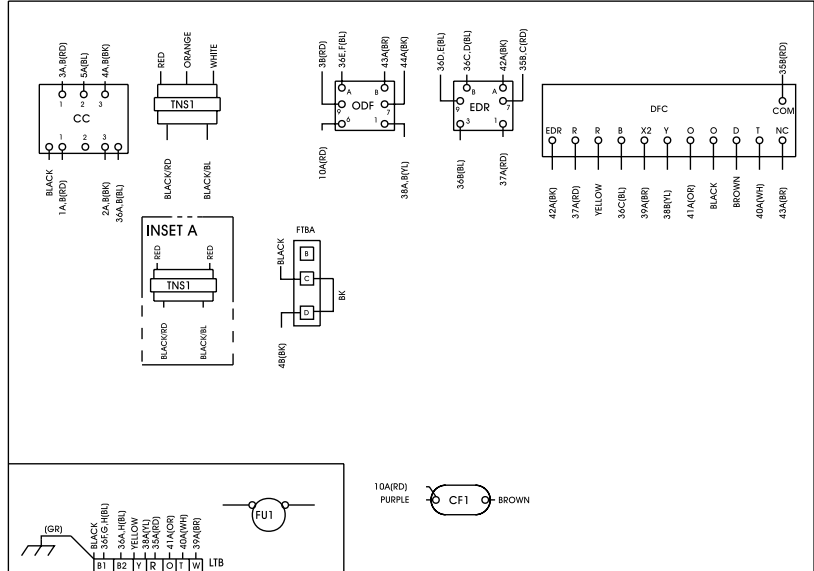

NOTES:

1. LOW VOLTAGE WIRING MUST BE 18 AWG MIN.
2. MAX. EXTERNAL LOW VOLTAGE LOAD 1.8 AMPS 24 V.A.C. DOES NOT INCLUDE ACCESSORIES BUT DOES INCLUDE INDOOR BLOWER RELAY.
3. SEE WIRING DIAGRAM WITH HEATER FOR DETAILS OF HEATER WIRING.
4. CONNECTIONS SHOWN ARE FOR 230V/60HZ/3PH. WHEN 208V/60HZ/3PH OPERATION IS REQUIRED:
- (A) AT TRANSFORMER REMOVE 1(RD) WIRE FROM RED WIRE AND CONNECT TO ORANGE WIRE. THE RED WIRE MUST BE RE-TERMINATED TO AVOID ACCIDENTLY SHORTING.
5. IF EVAPORATOR DEFROST CONTROL (EDC) IS USED, REMOVE JUMPER BETWEEN 'B1' AND 'B2'.
6. CONNECTIONS FOR THE 230V/3PH/60HZ UNIT ARE SHOWN. FOR 400V, 460V, AND 575V UNITS SEE TRANSFORMER CONNECTIONS IN INSETS A AND B.

NOTE
THREE PHASE MOTOR (S) FACTORY SUPPLIED IN THIS EQUIPMENT. PROTECTED UNDER PRIMARY SINGLE-PHASING CONDITIONS

TWA090A3
TWA090A4
TWA090AW
TWA120A4
TWA120AW
TWA075AD
TWA100AD

C757006P06

Typical Wiring

(Heat Pump)

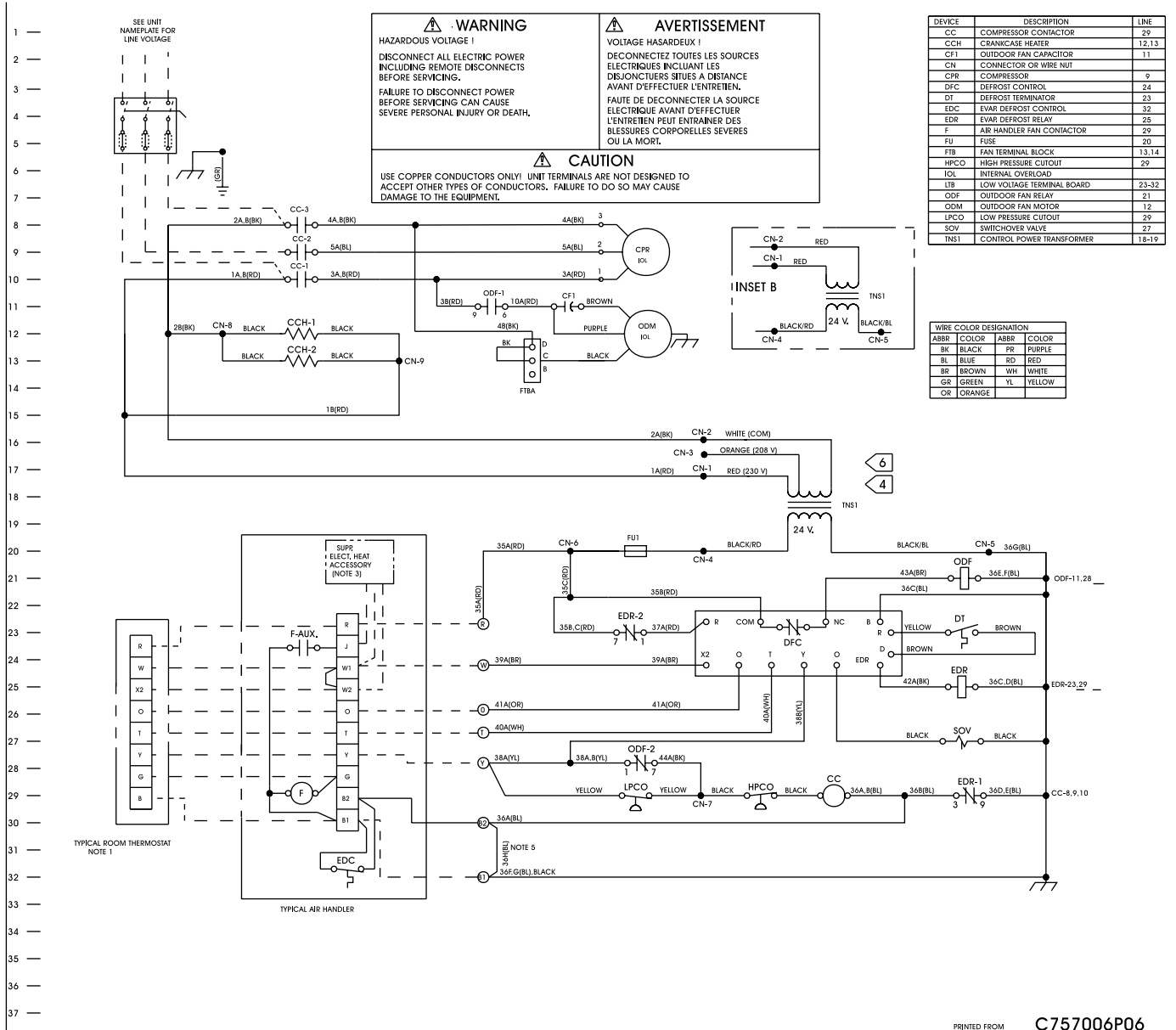

Typical Wiring

(Heat Pump)

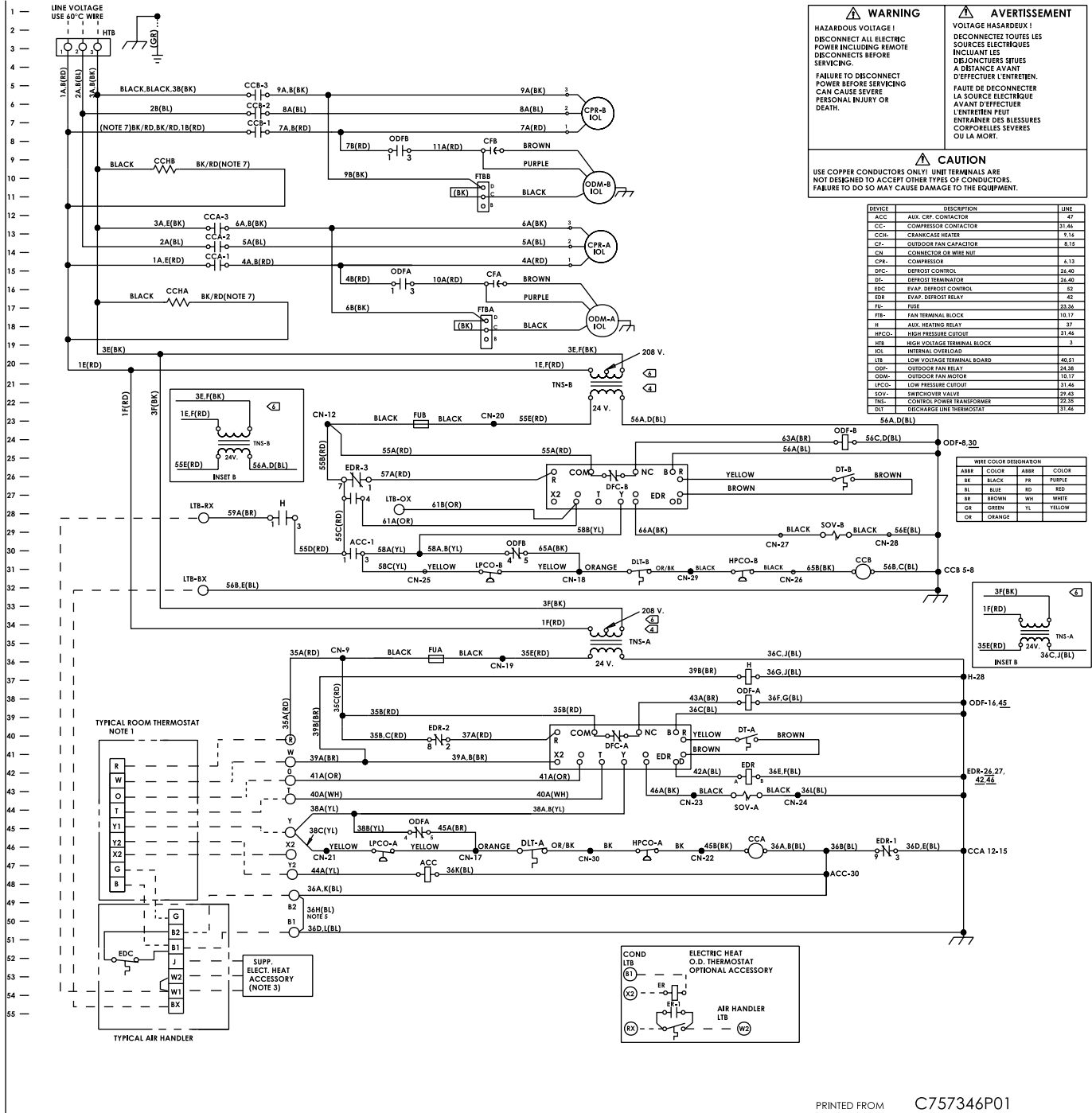

WARNING
 HAZARDOUS VOLTAGE!
 DISCONNECT ALL ELECTRIC POWER INCLUDING REMOTE DISCONNECTS BEFORE SERVICING.
 FAILURE TO DISCONNECT POWER BEFORE SERVICING CAN CAUSE SEVERE PERSONAL INJURY OR DEATH.

AVERTISSEMENT
 VOLTAGE HASARDEUX!
 DECONNECTEZ TOUTES LES SOURCES ELECTRIQUES INCLUANT LES DISCONNECTEURS SITUES A DISTANCE AVANT D'EFFECTUER L'ENTRETIEN.
 FAUTE DE DECONNECTER LA SOURCE ELECTRIQUE AVANT D'EFFECTUER L'ENTRETIEN PEUT ENTRAINER DES BLESSURES CORPORELLES SEVERES OU LA MORT.

CAUTION
 USE COPPER CONDUCTORS ONLY! UNIT TERMINALS ARE NOT DESIGNED TO ACCEPT OTHER TYPES OF CONDUCTORS. FAILURE TO DO SO MAY CAUSE DAMAGE TO THE EQUIPMENT.

DEVICE	DESCRIPTION	LINE
ACC	AUX. CRF. CONTACTOR	47
CC	COMPRESSOR CONTACTOR	31-44
CCN	CRANKCASE HEATER	9-14
CF	OUTDOOR FAN CAPACITOR	8-15
CN	CONNECTOR OR WIRE NUT	
CPR	COMPRESSOR	6-13
EDC	DEFROST CONTROL	24-40
EDR	DEFROST TERMINATOR	24-40
EDC	EVAP. DEFROST CONTROL	52
EDR	EVAP. DEFROST RELAY	52
HTB	HTB	23-36
ITB	FAN TERMINAL BLOCK	10-17
J	AUX. HEATING RELAY	37
HPHCL	HIGH PRESSURE CUTOUT	31-44
HTB	HIGH VOLTAGE TERMINAL BLOCK	3
IOL	INTERNAL OVERLOAD	
LTB	LOW VOLTAGE TERMINAL BOARD	46-51
ODP	OUTDOOR FAN RELAY	24-38
ODM	OUTDOOR FAN MOTOR	10-17
LPCCO	LOW PRESSURE CUTOUT	31-44
SOV	SWITCHOVER VALVE	27-43
TNS	CONTROL POWER TRANSFORMER	22-35
DT	DISCHARGE LINE THERMOSTAT	31-44

WIRE COLOR DESIGNATION	WIRE COLOR	AMBR	COLOR
AMBR	BLACK	PR	PURPLE
BL	BLUE	RD	RED
BR	BROWN	WH	WHITE
GR	GREEN	YL	YELLOW
OR	ORANGE		

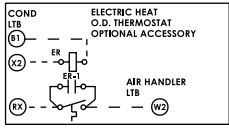

Typical Wiring (Air Handler)

Air Handler

Typical unit wiring diagram. For specific wiring, see individual Service Facts.

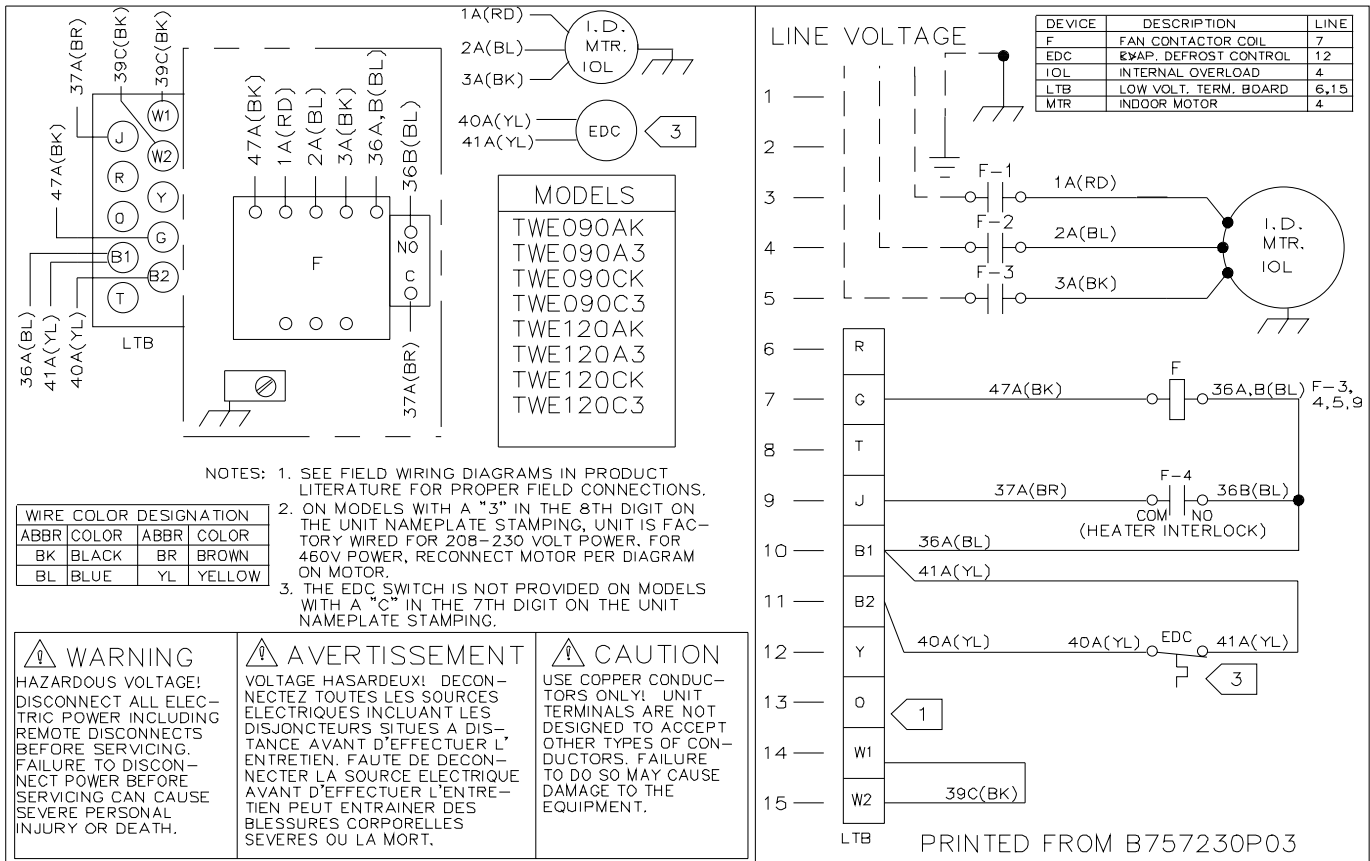

Dimensional Data

(Heat Pump)

Figure DD-1 — TWA075 Heat Pump

All dimensions are in inches and millimeters.

TOP DISCHARGE AREA SHOULD BE UNRESTRICTED FOR 90"/2290mm MINIMUM. UNIT SHOULD BE PLACED SO ROOF RUN-OFF WATER DOES NOT POUR DIRECTLY ON UNIT.

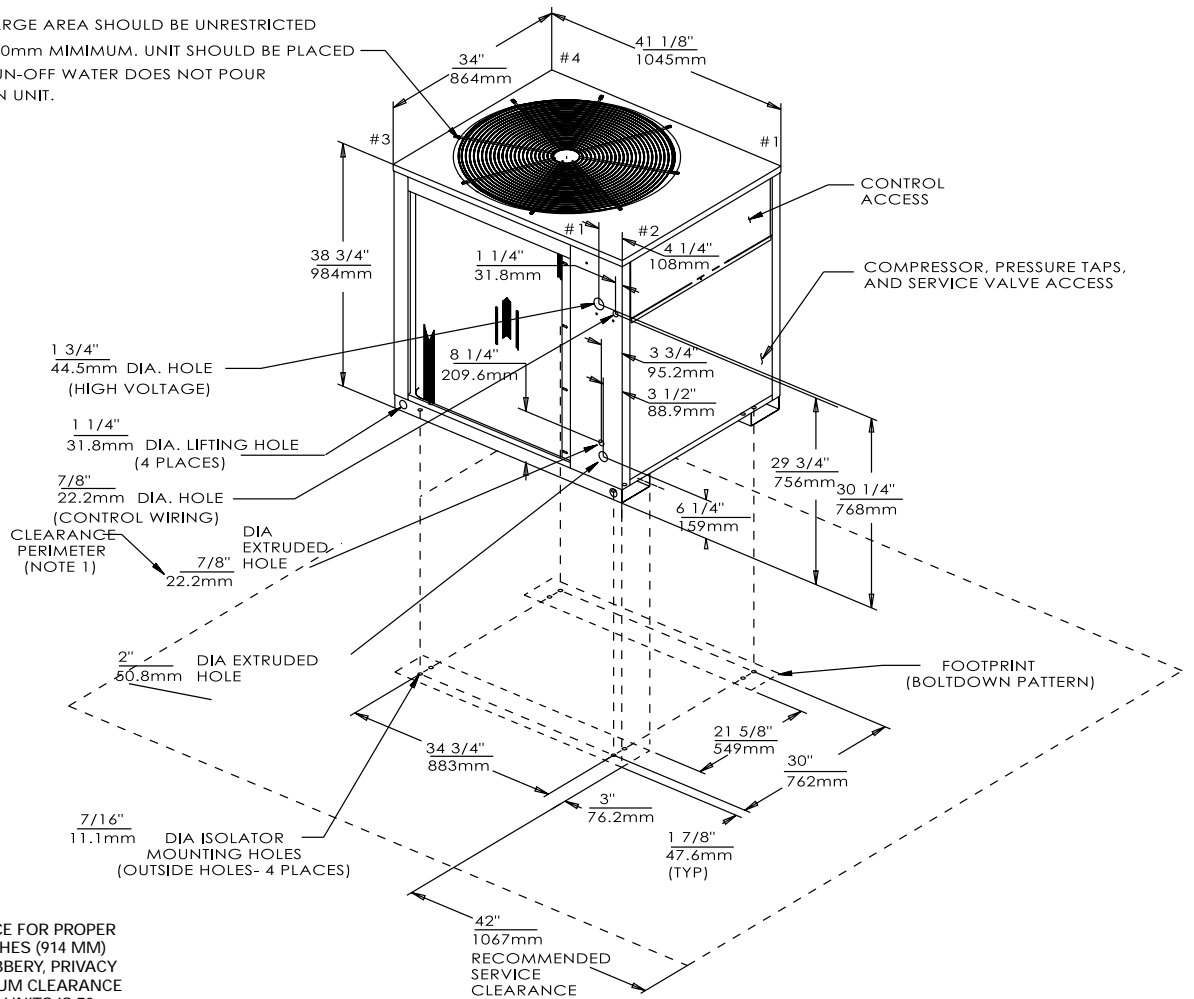

Dimensional Data

(Heat Pump)

Figure DD-2 — 10 Ton TWA100A Heat Pump

All dimensions are in inches and millimeters.

TOP DISCHARGE AREA SHOULD BE UNRESTRICTED FOR 100"/2540mm MINIMUM. UNIT SHOULD BE PLACED SO ROOF RUN-OFF WATER DOES NOT POUR DIRECTLY ON UNIT.

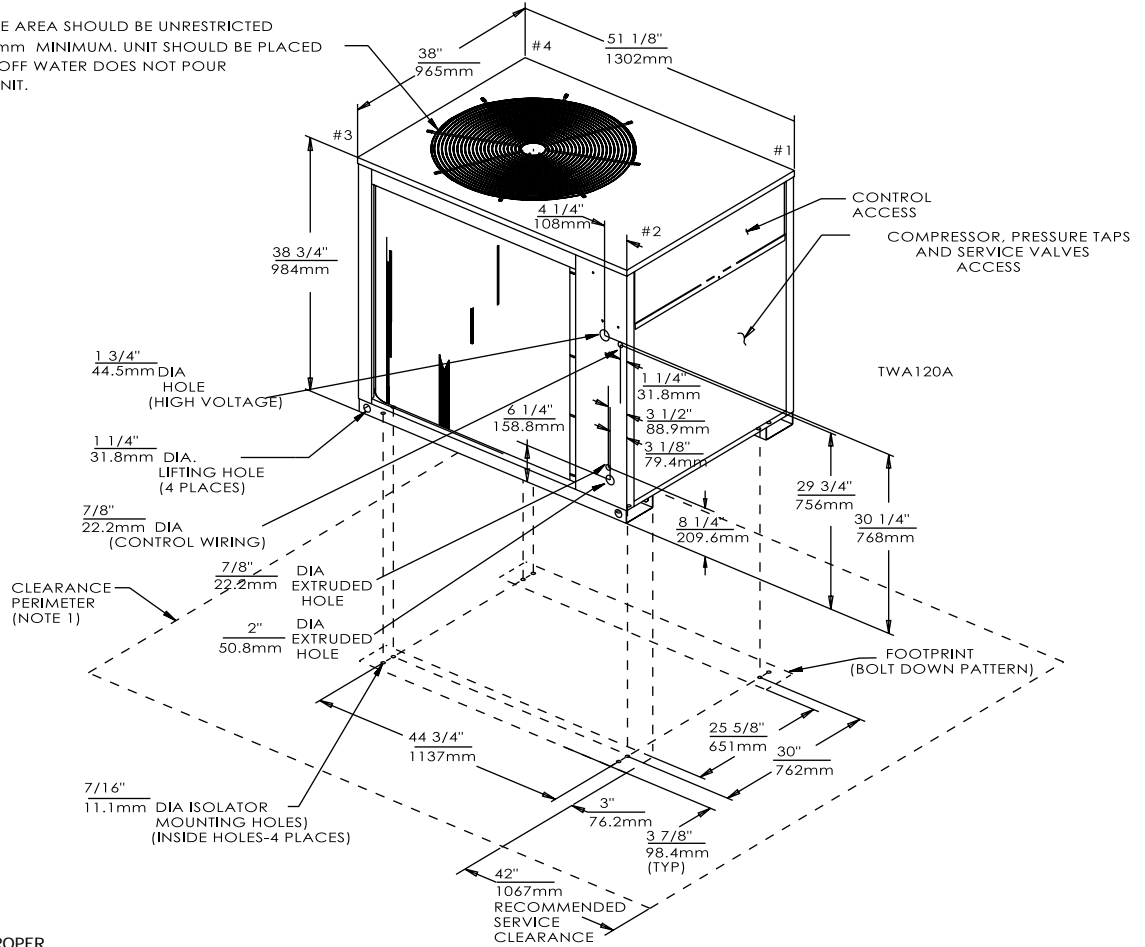

Note 1
MINIMUM CLEARANCE FOR PROPER OPERATION IS 36 INCHES (914 MM) FROM WALLS, SHRUBBERY, PRIVACY FENCES, ETC. MINIMUM CLEARANCE BETWEEN ADJACENT UNITS IS 72 INCHES (1828 MM)

Dimensional Data

(Heat Pump)

Figure DD-3 — TWA155B Heat Pump

All dimensions are in inches and millimeters.

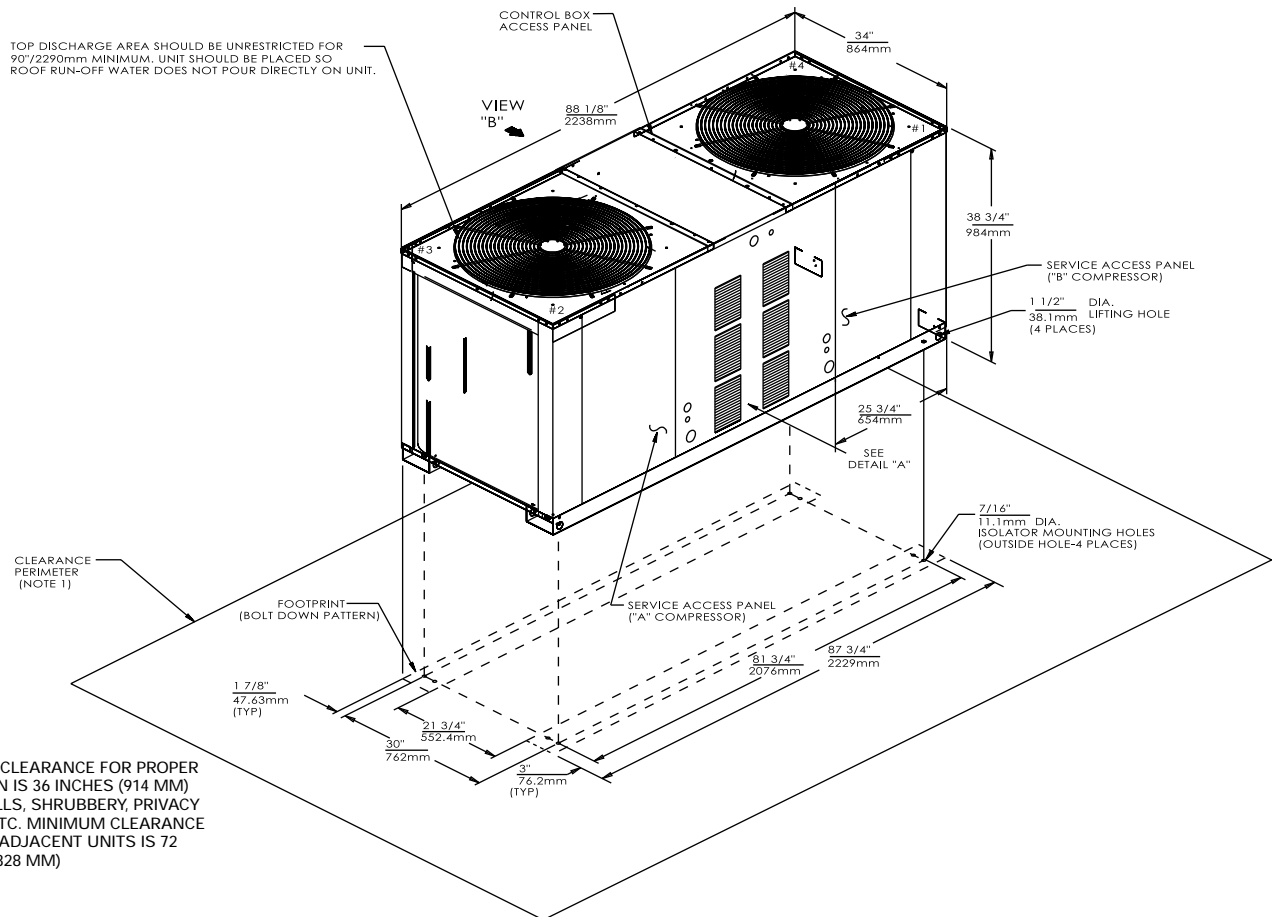

Note 1
 MINIMUM CLEARANCE FOR PROPER OPERATION IS 36 INCHES (914 MM) FROM WALLS, SHRUBBERY, PRIVACY FENCES, ETC. MINIMUM CLEARANCE BETWEEN ADJACENT UNITS IS 72 INCHES (1828 MM)

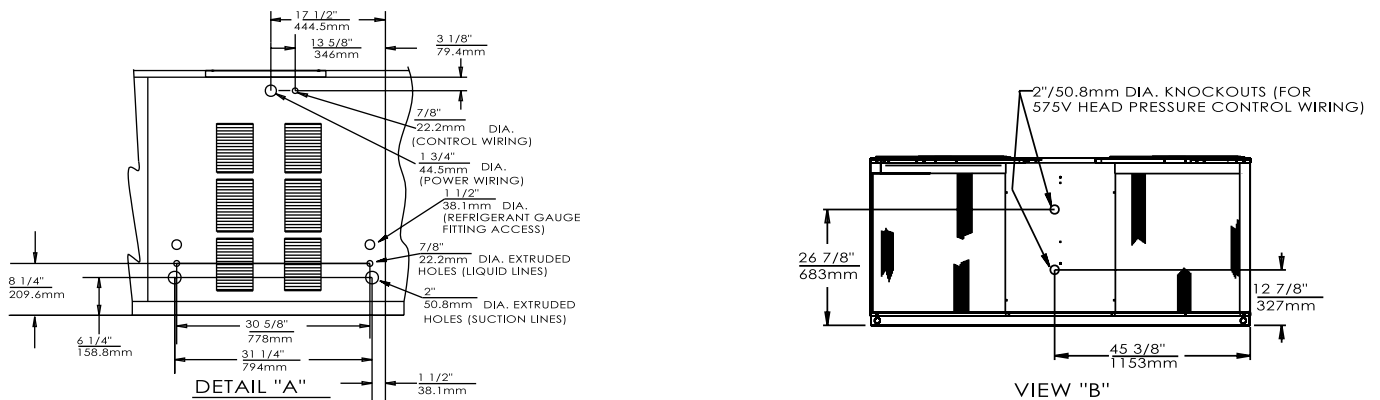

Dimensional Data

(Heat Pump)

Figure DD-4 — TWA200B Heat Pump

All dimensions are in inches and millimeters.

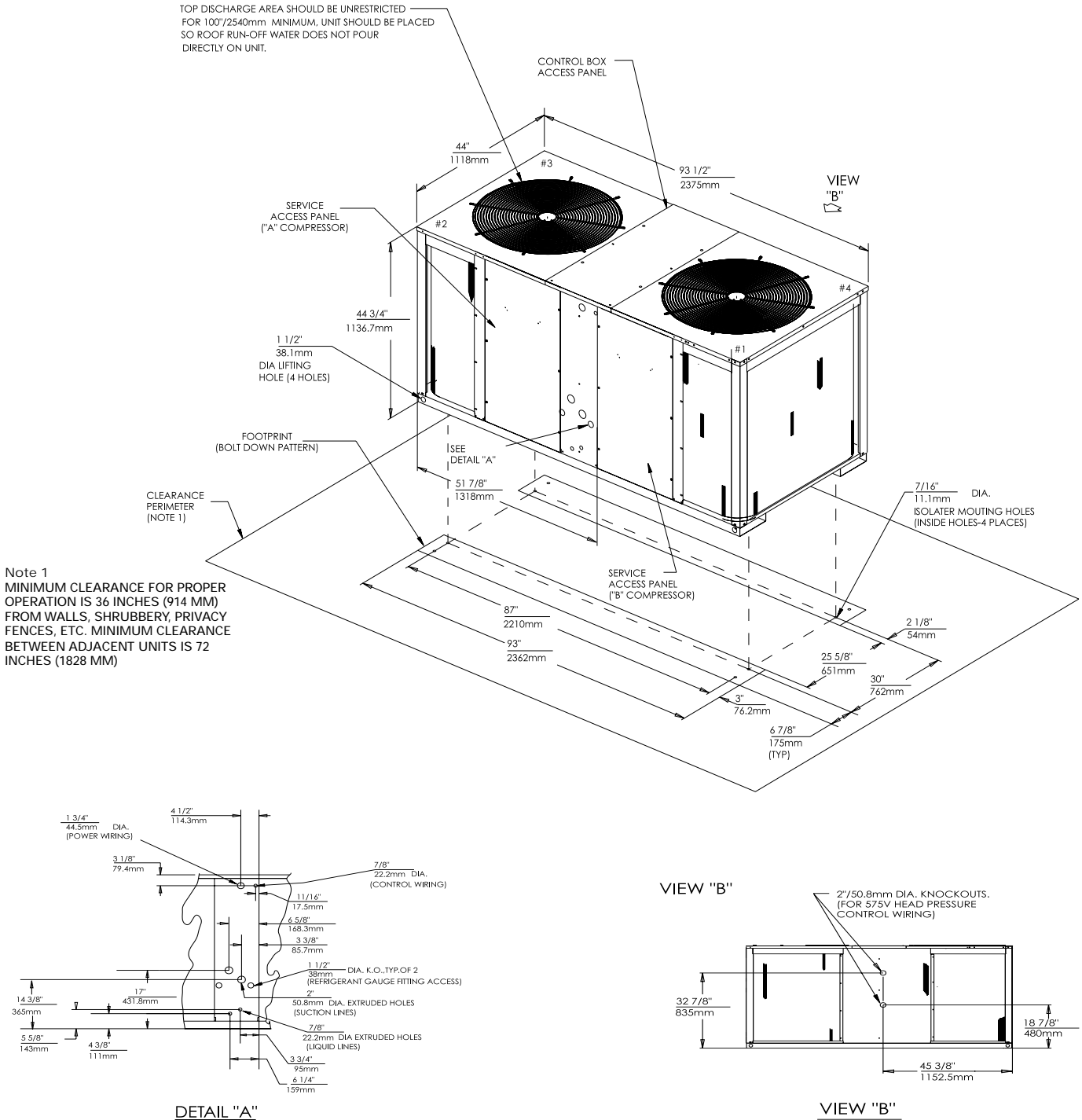

Dimensional Data

(Air Handler)

Figure DD-5 — TWE050A Air Handlers

All dimensions are in inches and millimeters.

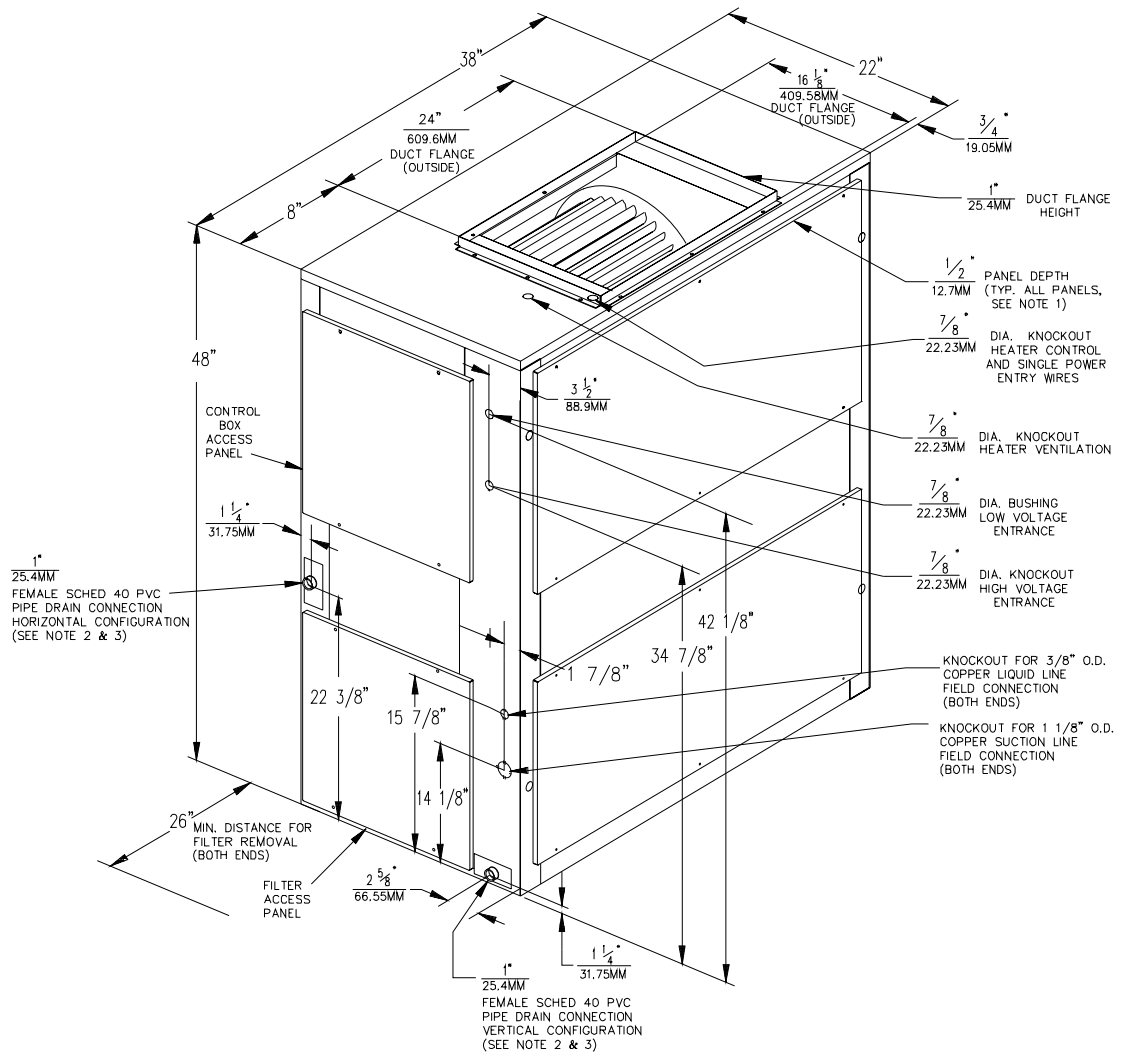

Notes:

1. Length, Width, and Height Dimensions do not include 1/2" (12.7mm) access panel depth.
2. Removable drain pan and attached drain connection may be installed on either end of unit in either the vertical or horizontal configuration. Plastic drain pan access plate on the end of unit opposite drain connection must be removed to slide drain pan out for cleaning. Access plate must be reinstalled after sliding drain pan back into unit.
3. If periodic drain pan cleaning is required, allow room for partial removal of pan on drain connection end of unit.

Dimensional Data (Air Handler)

Figure DD-6 — TWE075A Air Handler

All dimensions are in inches and millimeters.

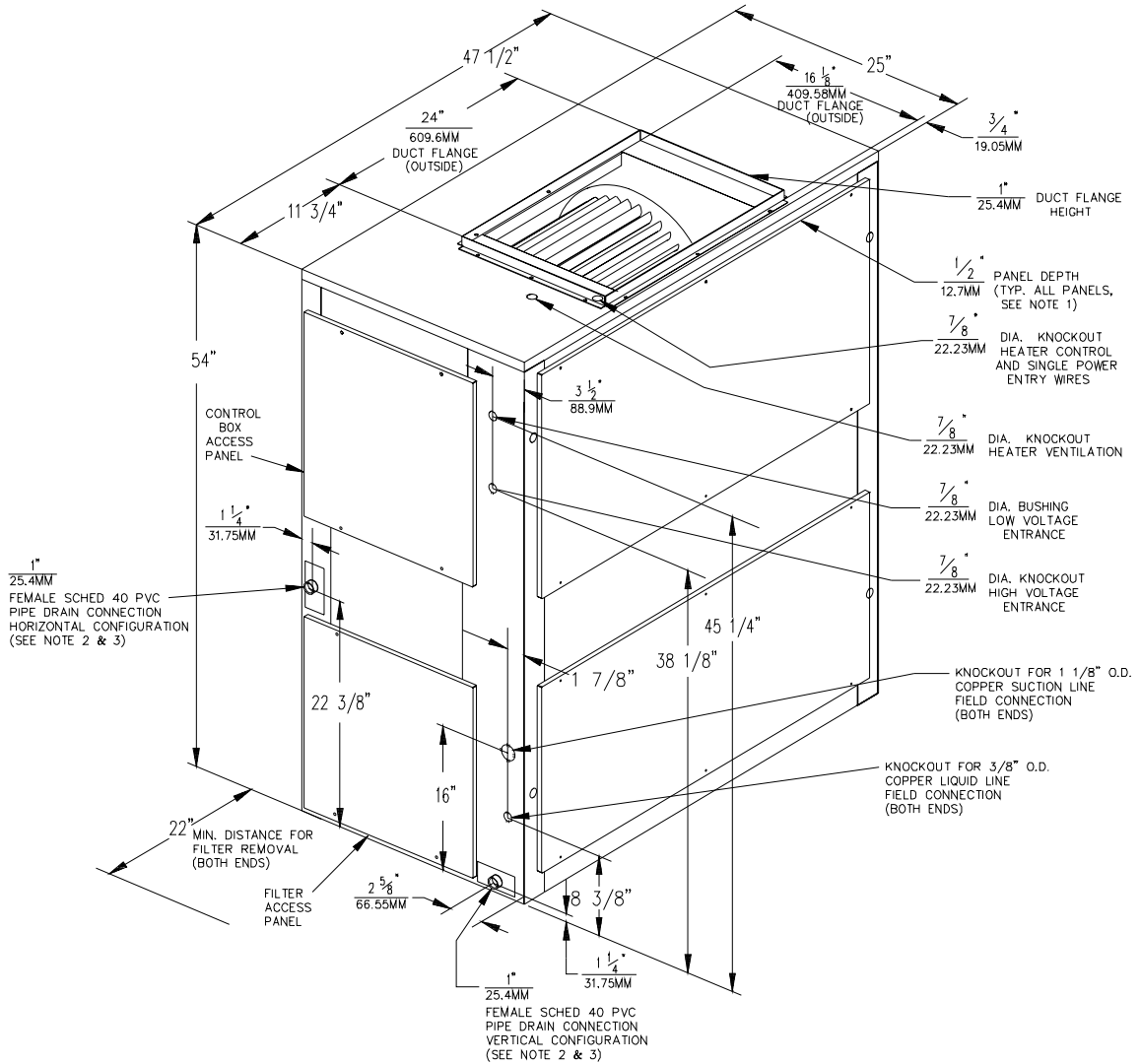

Notes:

1. Length, Width, and Height Dimensions do not include 1/2" (12.7mm) access panel depth.
2. Removable drain pan and attached drain connection may be installed on either end of unit in either the vertical or horizontal configuration. Plastic drain pan access plate on the end of unit opposite drain connection must be removed to slide drain pan out for cleaning. Access plate must be reinstalled after sliding drain pan back into unit.
3. If periodic drain pan cleaning is required, allow room for partial removal of pan on drain connection end of unit.

Dimensional Data

(Air Handler)

Figure DD-7—TWE100A Air Handler
All dimensions are in inches and millimeters.

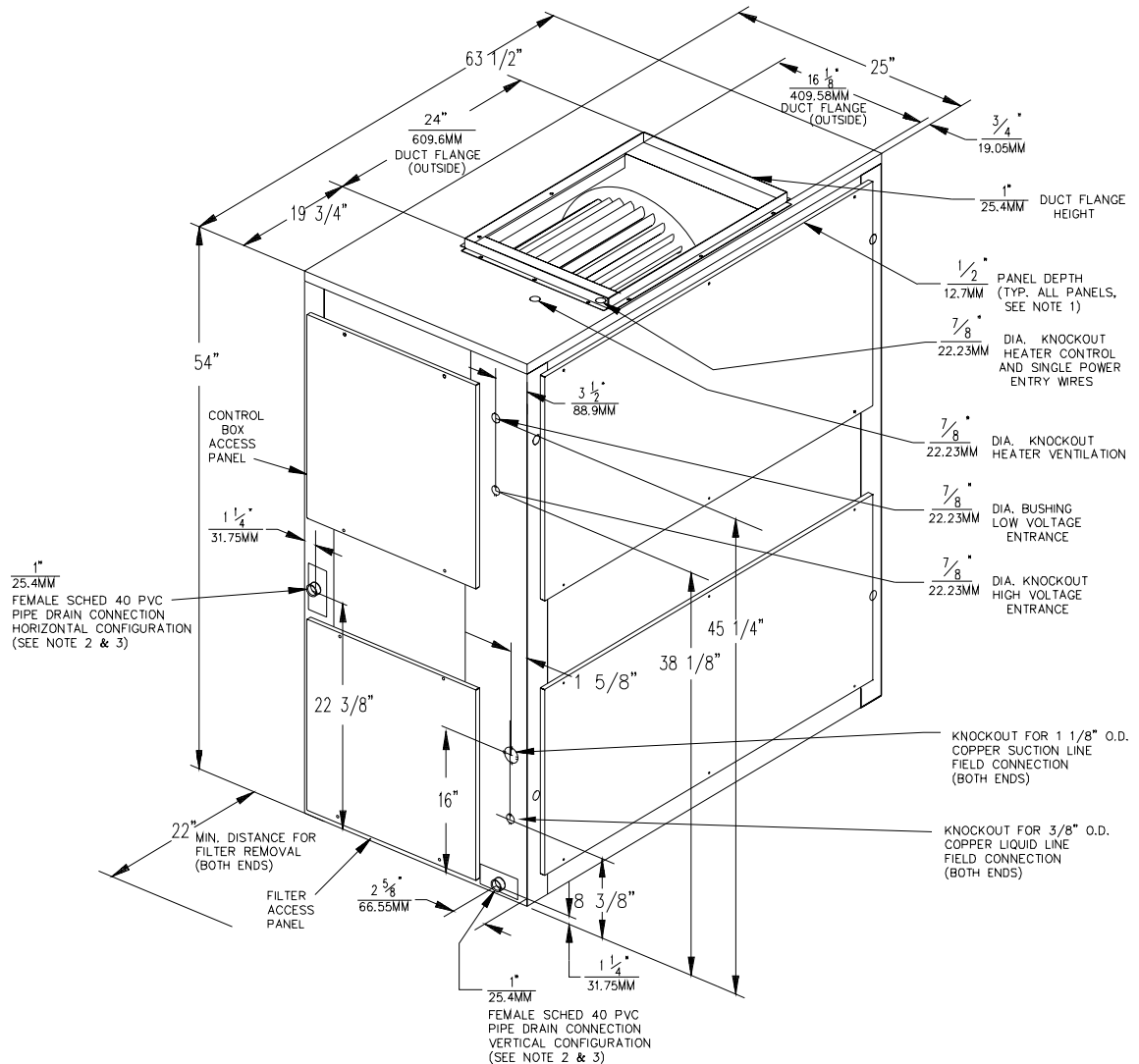

Notes:

1. Length, Width, and Height Dimensions do not include 1/2" (12.7mm) access panel depth.
2. Removable drain pan and attached drain connection may be installed on either end of unit in either the vertical or horizontal configuration. Plastic drain pan access plate on the end of unit opposite drain connection must be removed to slide drain pan out for cleaning. Access plate must be reinstalled after sliding drain pan back into unit.
3. If periodic drain pan cleaning is required, allow room for partial removal of pan on drain connection end of unit.

Dimensional Data

(Air Handler)

Figure DD-8—TWE100B Air Handler

All dimensions are in inches and millimeters.

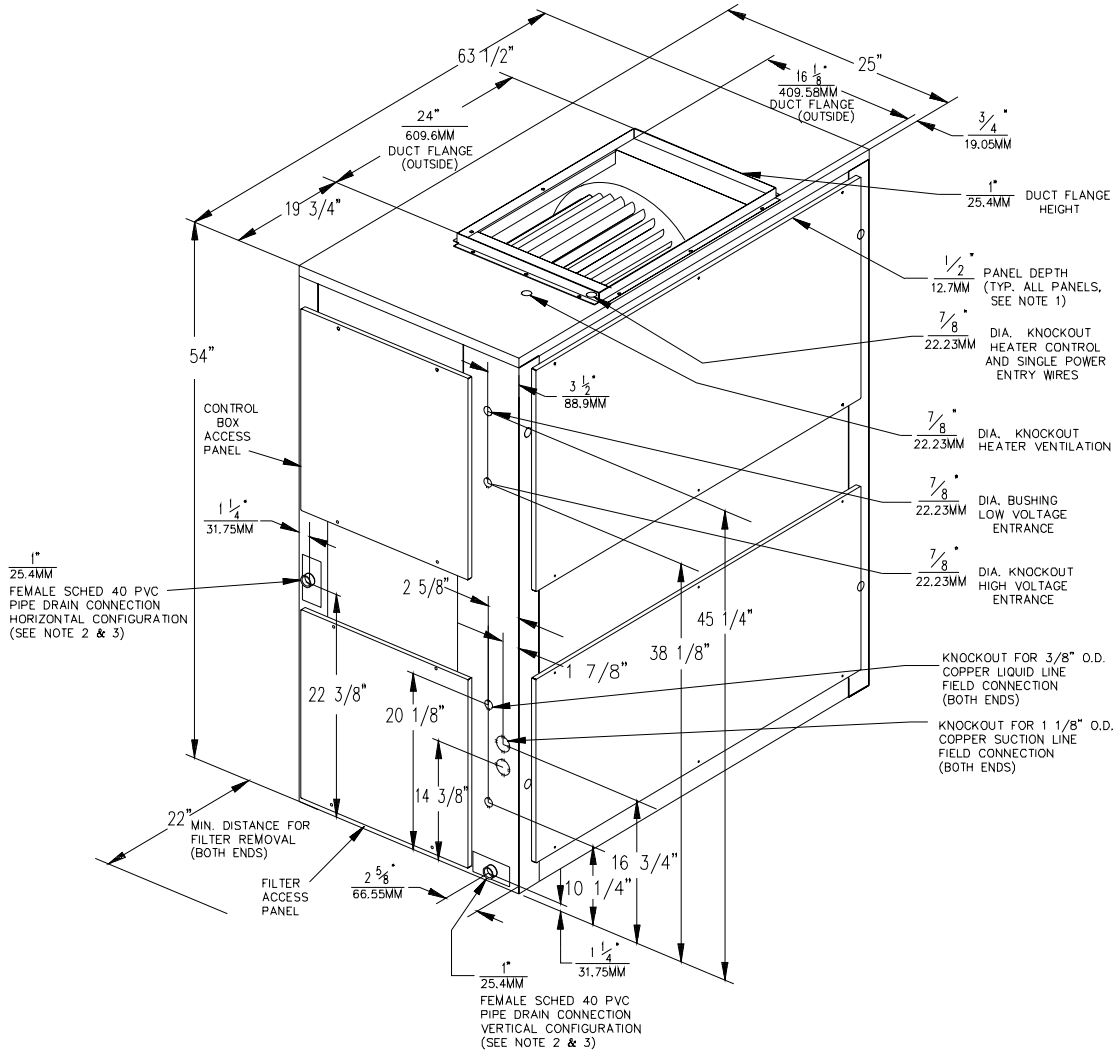

Notes:

1. Length, Width, and Height Dimensions do not include 1/2" (12.7mm) access panel depth.
2. Removable drain pan and attached drain connection may be installed on either end of unit in either the vertical or horizontal configuration. Plastic drain pan access plate on the end of unit opposite drain connection must be removed to slide drain pan out for cleaning. Access plate must be reinstalled after sliding drain pan back into unit.
3. If periodic drain pan cleaning is required, allow room for partial removal of pan on drain connection end of unit.

Dimensional Data

(Air Handlers)

Figure DD-9— TWE050A, 075A, 100A and TWE100B Air Handler

All dimensions are in inches and millimeters.

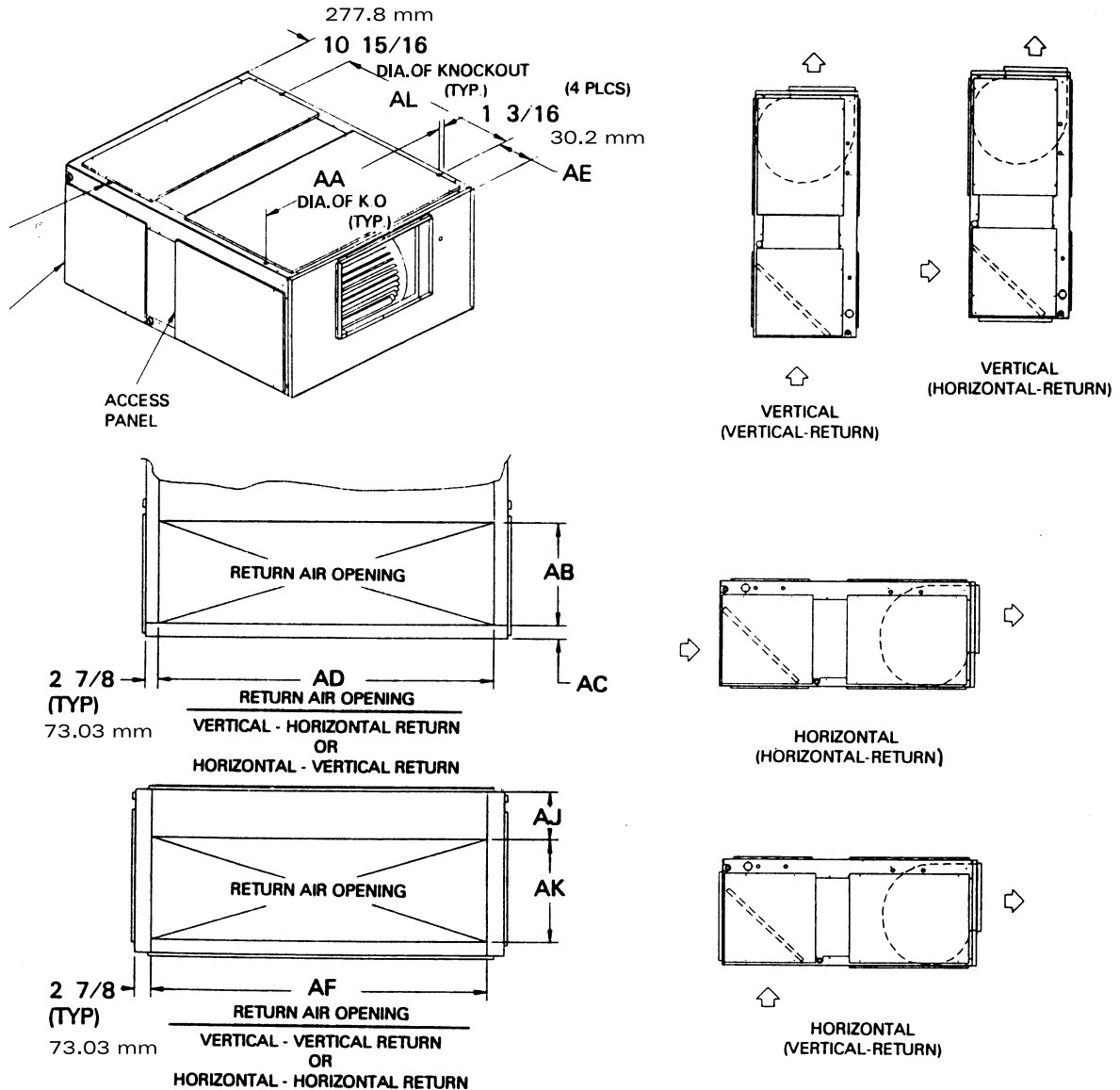

Table DD-1 — Air Handler Dimensions — in. (mm)

Model No.	AA	AB	AC	AD	AE	AF	AJ	AK	AL
TWE050A	35 5/8 (905)	12 1/16 (306.4)	1 5/8 (41.3)	32 1/4 (819.2)	2 15/16 (74.6)	32 1/4 (819.2)	7 13/16 (198.4)	12 3/8 (314.3)	34 9/16 (878)
TWE075A	45 1/8 (1146.2)	16 (406.4)	1 11/16 (42.9)	41 15/16 (1065.2)	6 5/8 (168.3)	41 3/4 (1060.5)	7 (177.8)	16 (406.4)	36 7/8 (936.6)
TWE100A	61 1/8 (1552.6)	16 (406.4)	1 11/16 (42.9)	57 15/16 (1471.6)	6 5/8 (168.3)	57 13/16 (1468.4)	7 (177.8)	16 (406.4)	36 7/8 (936.6)
TWE100B	61 1/8 (1552.6)	16 (406.4)	1 11/16 (42.9)	57 15/16 (1471.6)	6 5/8 (168.3)	57 13/16 (1468.4)	7 (177.8)	16 (406.4)	36 7/8 (936.6)

Dimensional Data

(Air Handler)

Figure DD-10— TWE155B Air Handler

All dimensions are in inches and millimeters.

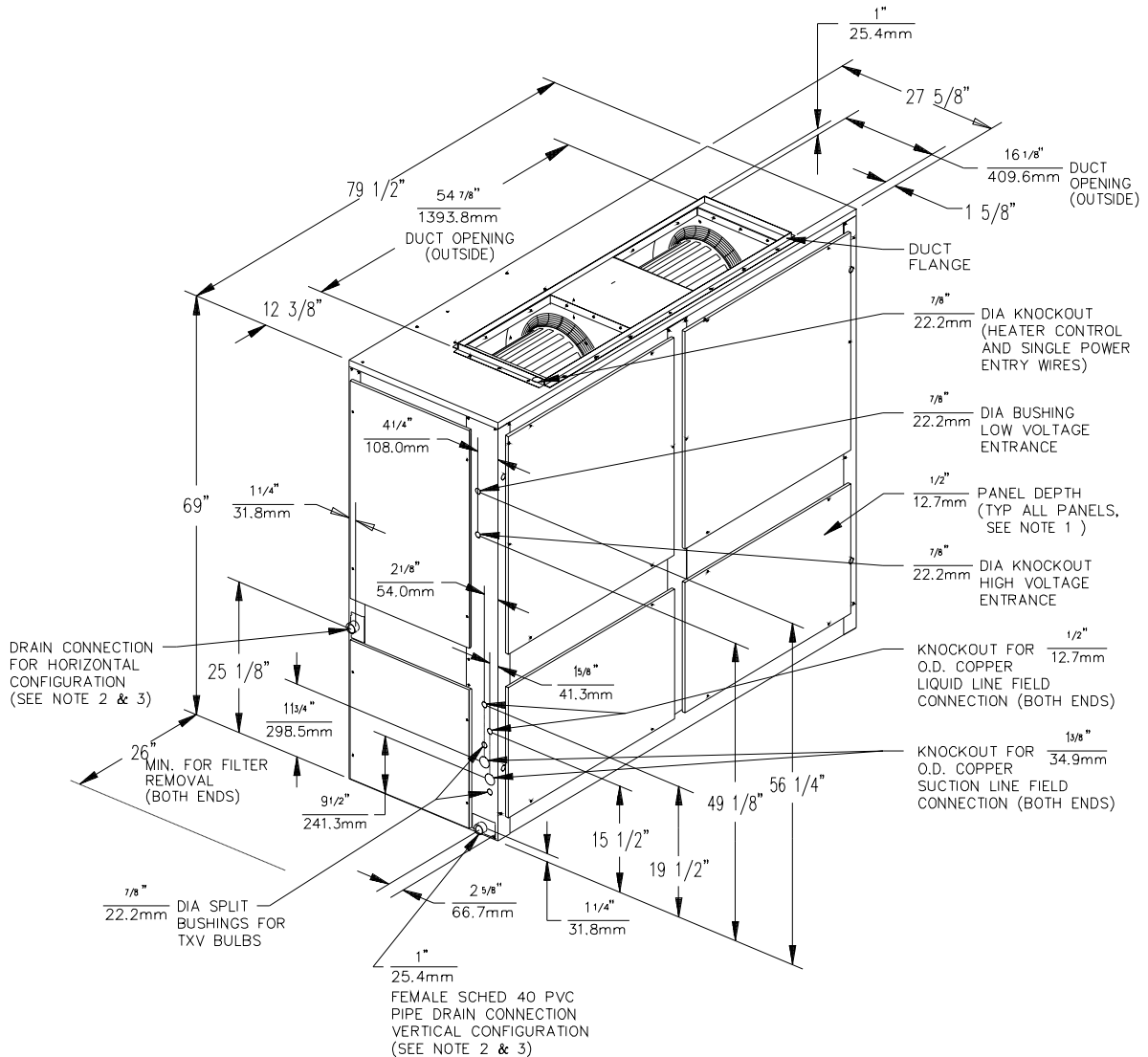

Notes:

1. Length, Width, and Height Dimensions do not include 1/2" (12.7mm) access panel depth.
2. Removable drain pan and attached drain connection may be installed on either end of unit in either the vertical or horizontal configuration. Plastic drain pan access plate on the end of unit opposite drain connection must be removed to slide drain pan out for cleaning. Access plate must be reinstalled after sliding drain pan back into unit.
3. If periodic drain pan cleaning is required, allow room for partial removal of pan on drain connection end of unit.

Dimensional Data

(Air Handlers)

Figure DD-11 — TWE200B Air Handler

All dimensions are in inches and millimeters.

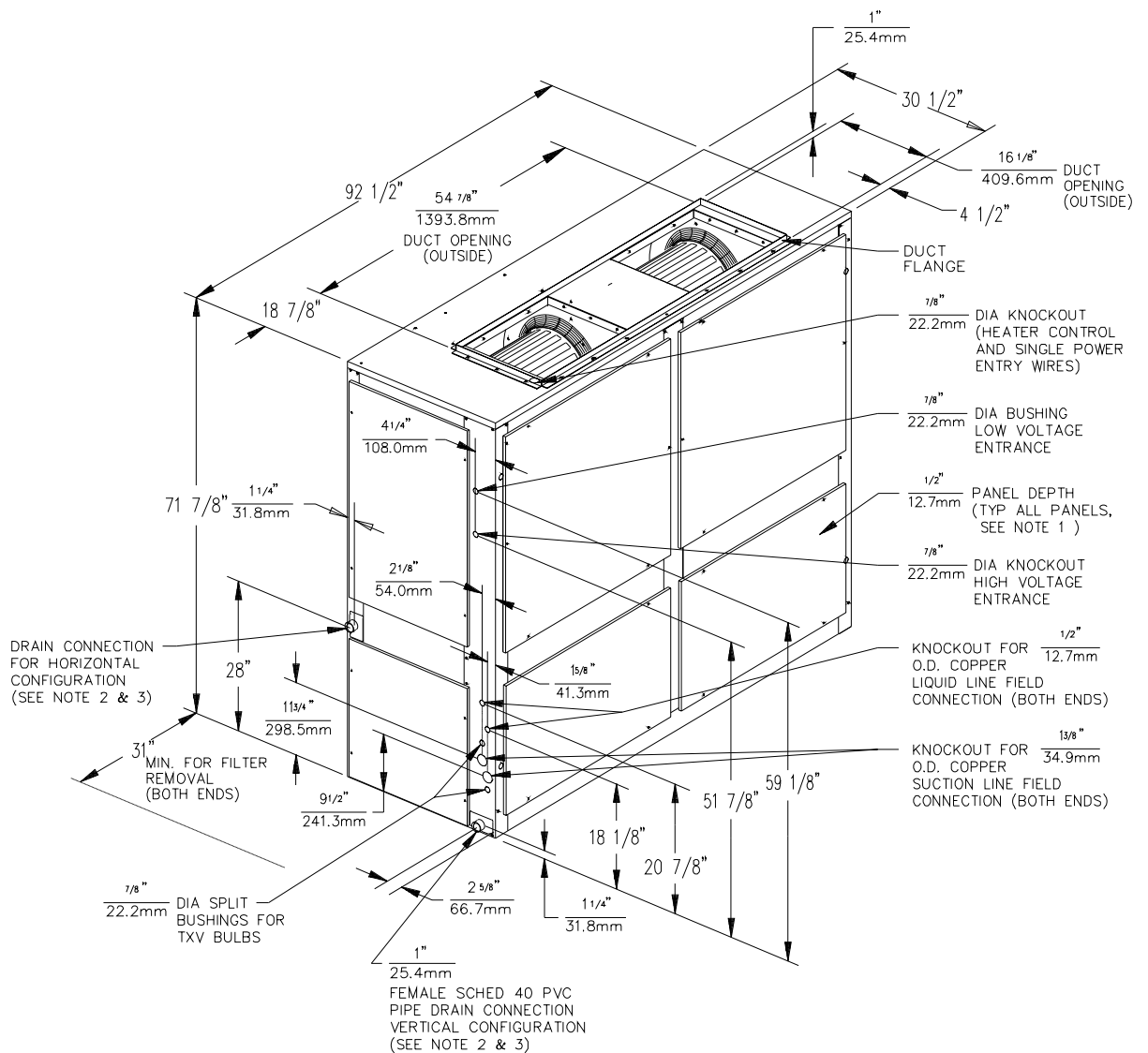

Notes:

1. Length, Width, and Height Dimensions do not include 1/2" (12.7mm) access panel depth.
2. Removable drain pan and attached drain connection may be installed on either end of unit in either the vertical or horizontal configuration. Plastic drain pan access plate on the end of unit opposite drain connection must be removed to slide drain pan out for cleaning. Access plate must be reinstalled after sliding drain pan back into unit.
3. If periodic drain pan cleaning is required, allow room for partial removal of pan on drain connection end of unit.

Dimensional Data (Air Handlers)

Figure DD-12—TWE155B and 200B Air Handlers

All dimensions are in inches and millimeters.

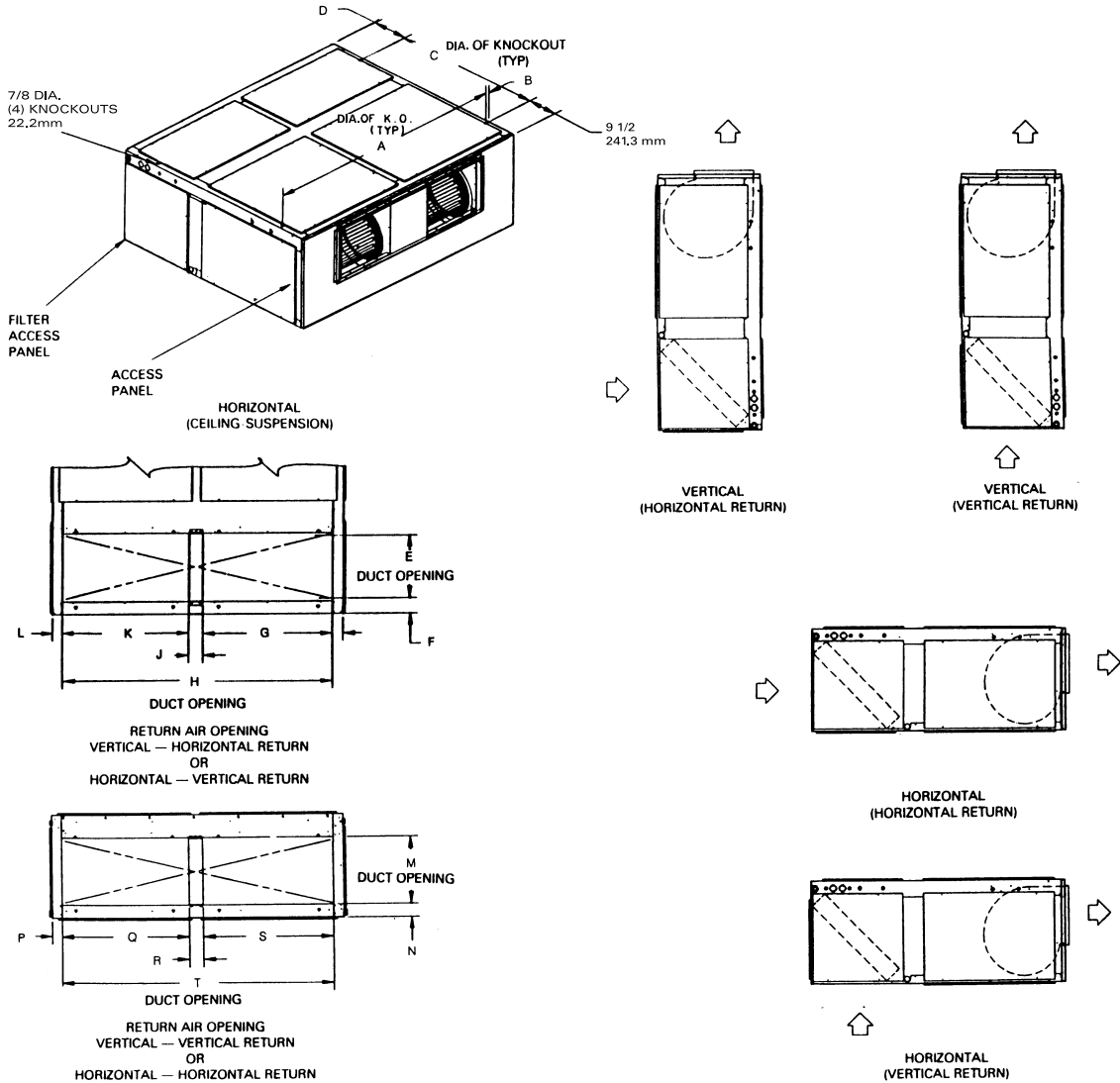

Table DD-2 — Air Handler Dimensions — in. (mm)

Model No.	A	B	C	D	E	F	G	H	J
TWE155B	77 1/4 (1962.2)	1 3/16 (30.2)	48 (1219.2)	11 7/16 (290.5)	18 (457.2)	3 3/8 (85.7)	35 1/16 (890.6)	73 7/8 (1876.4)	3 3/4 (95.3)
TWE200B	89 1/4 (2267)	1 11/16 (42.9)	50 13/16 (1290.6)	11 1/2 (292.1)	20 1/8 (511.2)	3 1/16 (77.8)	39 1/8 (993.8)	82 7/8 (2105)	4 9/16 (115.9)

Table DD-2— Air Handler Dimensions — in. (mm) (Continued)

Model No.	K	L	M	N	P	Q	R	S	T
TWE155B	35 1/16 (890.6)	2 13/16 (71.4)	18 (457.2)	3 9/16 (90.5)	2 7/8 (73)	35 1/16 (890.6)	3 3/4 (95.3)	35 1/16 (890.6)	73 3/8 (1863.7)
TWE200B	39 1/8 (993.8)	4 7/8 (123.8)	20 (508)	3 (76.2)	4 13/16 (122.2)	39 1/8 (993.8)	4 9/16 (115.9)	39 1/8 (993.8)	82 7/8 (2105)

Dimensional Data

(Accessories)

Figure DD-13— Electric Heater for TWE050, 075, 100 Air Handlers

All dimensions are in inches and millimeters.

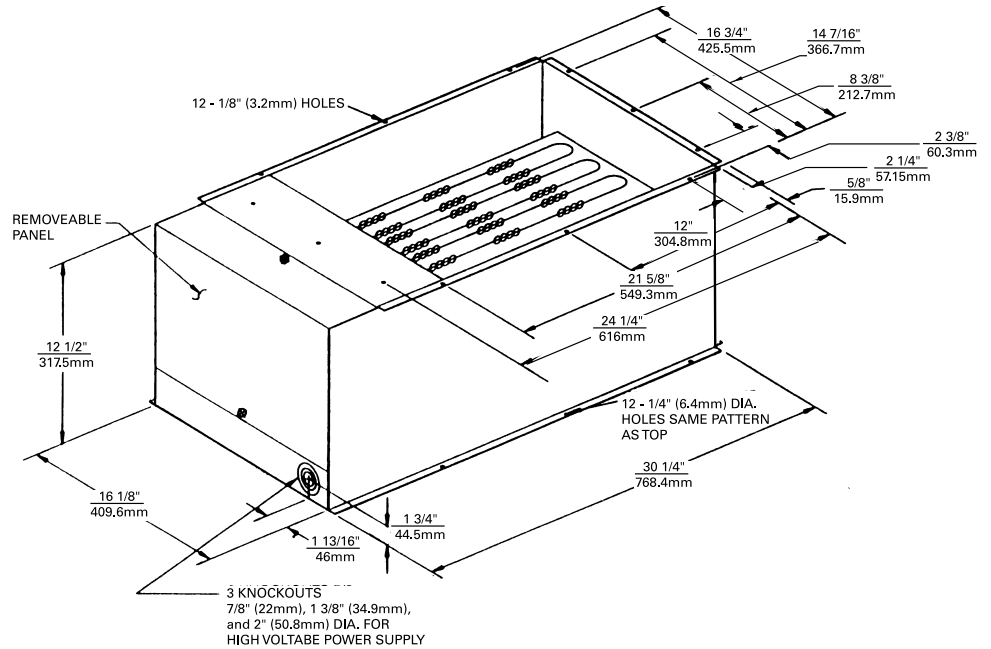
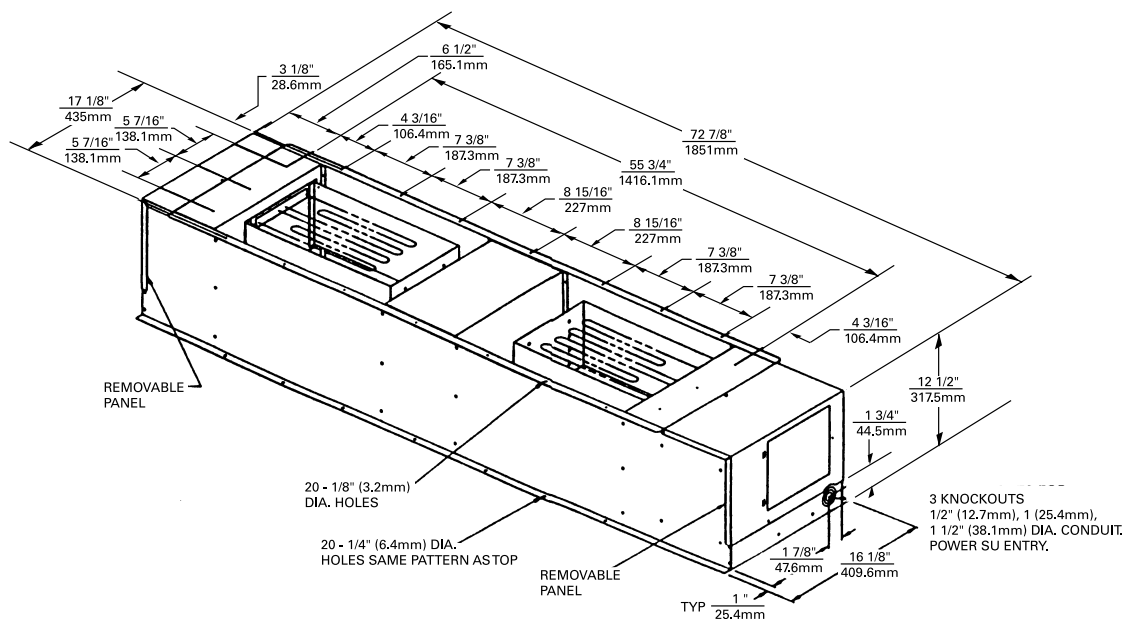

Figure DD-14 — Electric Heater for TWE155 and 200 Air Handlers



Dimensional Data

(Accessories)

Table DD-3 — Discharge Plenum And Grille Dimensions — in. (mm)

Model	Model No.	A	B	C
TWE050	BAYPLNM015	37 ¹⁵ / ₁₆ (963.6)	21 ¹⁵ / ₁₆ (557.2)	28 (711.2)
TWE075	BAYPLNM016	47 ¹ / ₂ (1206.5)	25 (635)	28 (711.2)
TWE100	BAYPLNM017	63 ¹ / ₂ (1612.9)	25 (635)	28 (711.2)

**Table DD-4 — Discharge Plenum And Grille Dimensions — in. (mm)
For Use with Electric Heat**

Model	Model No.	A	B	C
TWE050	BAYPLNM025	37 ¹⁵ / ₁₆ (963.6)	21 ¹⁵ / ₁₆ (557.2)	29 (736.6)
TWE075	BAYPLNM026	47 ¹ / ₂ (1206.5)	25 (635)	29 (736.6)
TWE100	BAYPLNM027	63 ¹ / ₂ (1612.9)	25 (635)	29 (736.6)
TWE155	BAYPLNM028	79 ¹ / ₂ (2019.3)	27 ¹¹ / ₁₆ (703.3)	35 (889)
TWE200	BAYPLNM029	92 ¹ / ₂ (2349.5)	30 ⁷ / ₁₆ (773.1)	35 (889)

Figure DD-15 — Discharge Plenum and Grille
All dimensions are in inches and millimeters.

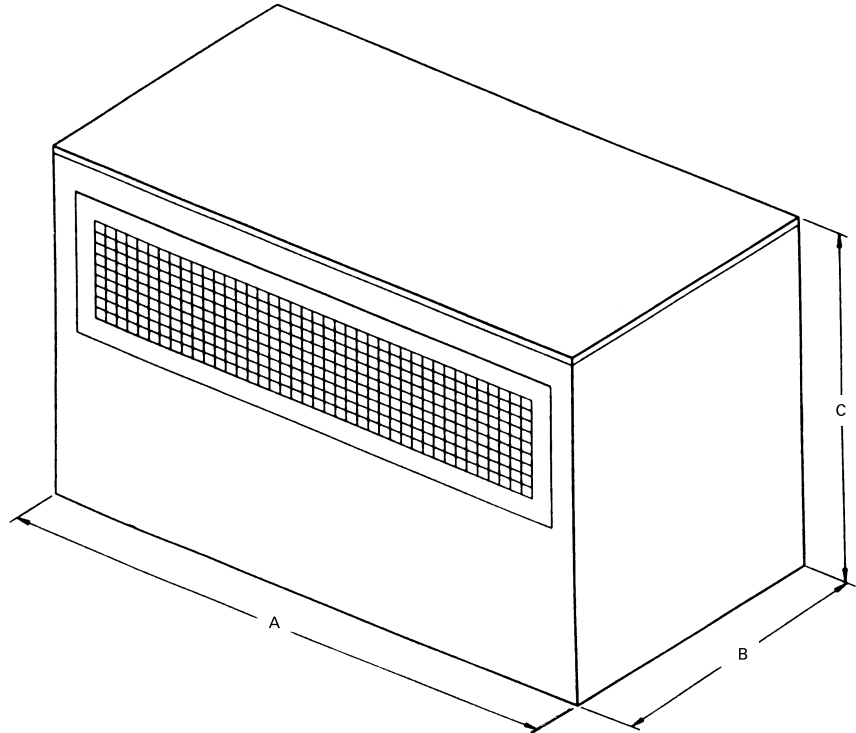
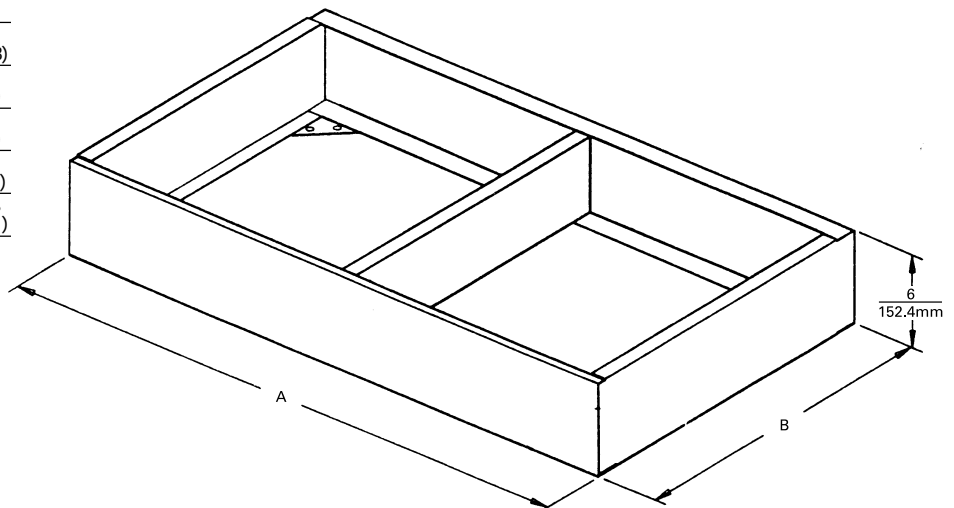

Table DD-5 — Subbase Dimensions — in. (mm)

Model	Model No.	A	B
TWE050	BAYBASE001	38 (965.2)	22 (558.8)
TWE075	BAYBASE002	47 ¹ / ₂ (1206.5)	25 (635)
TWE100	BAYBASE003	63 ¹ / ₂ (1612.9)	25 (635)
TWE155	BAYBASE004	79 ¹ / ₂ (2019.3)	27 ⁵ / ₈ (701.7)
TWE200	BAYBASE005	92 ¹ / ₂ (2349.5)	30 ⁷ / ₁₆ (773.1)

Figure DD-16 — Subbase



Weights (Heat Pumps)

Table W-1 — Unit and Corner Weights — lb (kg)

Unit Model No.	Shipping		Net			
	Maximum — lb (kg)	Maximum — lb (kg)	1	2	3	4
TWA075A	390 (176.9)	343 (155.6)	112 (50.8)	89 (40.4)	63 (28.6)	79 (35.8)
TWA100A	468 (212.3)	414 (187.8)	146 (66.2)	106 (48.1)	68 (30.1)	94 (42.6)
TWA155B	816 (370.1)	740 (335.7)	195 (88.5)	186 (84.4)	175 (79.4)	184 (83.5)
TWA200B	970 (440.0)	885 (401.4)	253 (114.8)	250 (113.4)	190 (86.2)	192 (87.1)

Table W-2 — Accessory Weights — Net lb (kg)

Unit Model No.	RIS Isolators	Steel Spring Isolators	Anti Short Cycle Timer	Coil Guard	Thermostats	Low Ambient
TWA075A	2 (.9)	12 (5.4)	1 (.5)	8 (3.6)	1 (.5)	23 (10.4)
TWA100A	2 (.9)	12 (5.4)	1 (.5)	11 (5)	1 (.5)	23 (10.4)
TWA155B	2 (.9)	12 (5.4)	1 (.5)	22 (10)	1 (.5)	23 (10.4)
TWA200B	2 (.9)	12 (5.4)	1 (.5)	34 (15.4)	1 (.5)	23 (10.4)

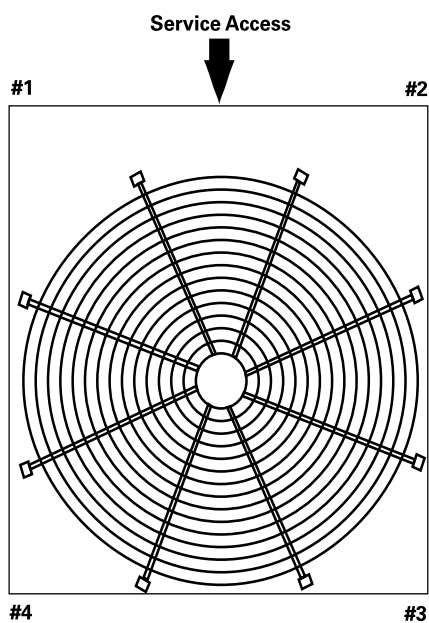

TWA075A, 100A

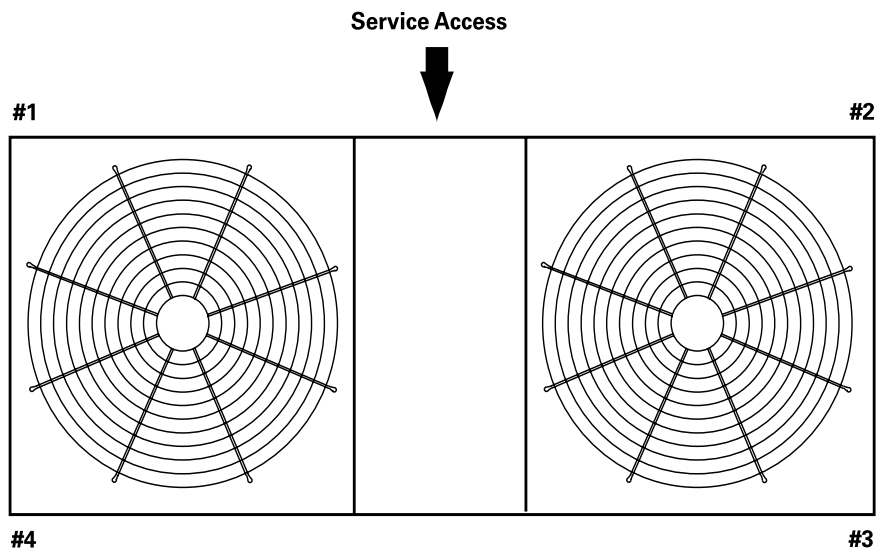

TWA155B, 200B

Weights (Air Handlers)

Table W-3 — Air Handlers, Coils, And Corner Weights — lb (kg)¹

Unit Model No.	Shipping Maximum (lbs)	Net Maximum (lbs)	Corner Weights — Vertical				Corner Weights — Horizontal			
			#1	#2	#3	#4	A	B	C	D
TWE050	298 (135)	262 (118.9)	59 (26.8)	59 (26.8)	59 (26.8)	59 (26.8)	54 (24.5)	64 (29)	64 (29.03)	54 (24.5)
TWE075	388 (176)	346 (157)	79 (35.9)	79 (35.9)	79 (35.9)	79 (35.9)	77 (35)	84 (38.1)	81 (36.7)	73 (33.1)
TWE100	473 (214.6)	419 (190.1)	107 (48.5)	107 (48.5)	107 (48.5)	107 (48.5)	102 (46.3)	113 (51.3)	113 (51.3)	102 (46.3)
TWE125	754 (342)	690 (313)	173 (78.5)	173 (78.5)	173 (78.5)	173 (78.5)	174 (79)	156 (70.8)	190 (86.2)	170 (77.1)
TWE200	886 (401.9)	820 (372)	204 (92.5)	204 (92.5)	204 (92.5)	204 (92.5)	185 (84)	228 (103.4)	221 (100.3)	179 (81.2)

Note:
1. If application requires steam or hot water heating coils, field supplied isolators must be utilized.

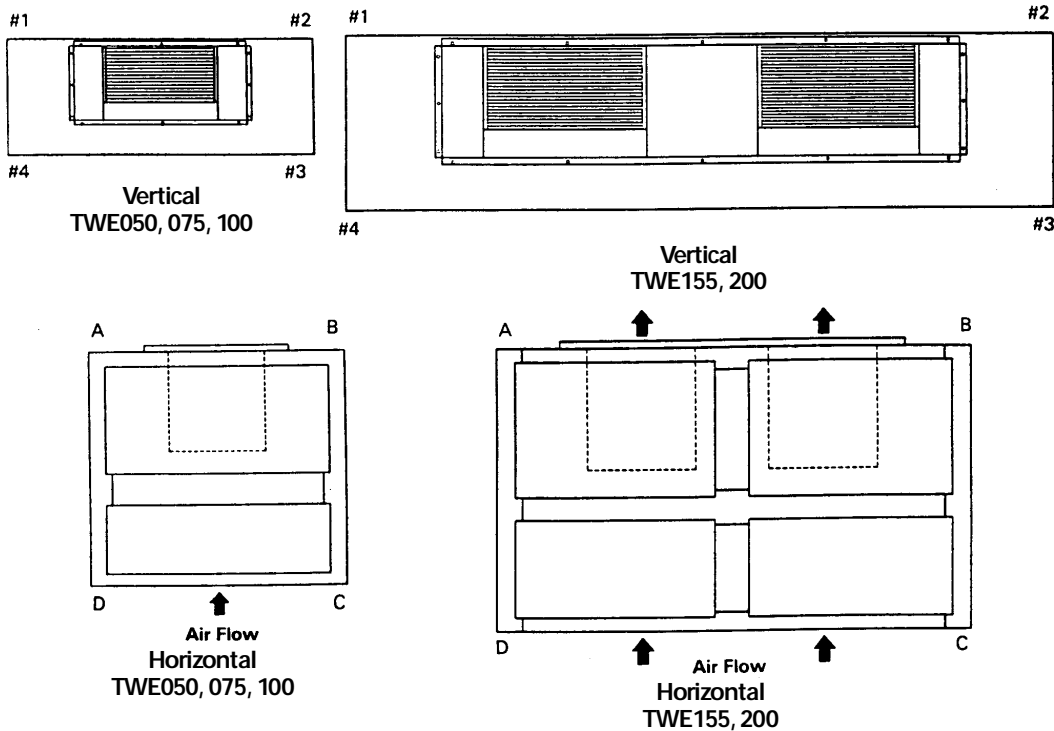

Table W-4— Accessory Weights — lb (kg)

Unit Model No.	Discharge Plenum And Grille ¹	Discharge Plenum And Grill ²	Return Air Grille	Electric Heat Min. Max.	Subbase	Oversized Motor	RIS Isolator Floor Mount	RIS Isolator Suspended Mount	Steel Spring Isolator Floor Mount	Steel Spring Isolator Suspended Mount
TWE050	58 (26.3)	93 (42.2)	3 (1.4)	32/43 (14.5/19.5)	14 (6.4)	31 (14.1)	2 (.9)	9 (4)	12 (5.4)	6 (2.7)
TWE075	73 (33.1)	123 (55.8)	5 (2.3)	27/45 (12.3/20.4)	19 (8.6)	48 (21.8)	2 (.9)	6 (2.7)	12 (5.4)	6 (2.7)
TWE100	92 (41.7)	156 (70.8)	7 (3.2)	27/45 (12.3/20.4)	23 (10.4)	50 (22.7)	2 (.9)	7 (3.2)	12 (5.4)	6 (2.7)
TWE155	124 (56.3)	230 (104.3)	10 (4.5)	79/100 (35.8/45.4)	27 (12.3)	80 (36.3)	2 (.9)	7 (3.2)	12 (5.4)	6 (2.7)
TWE200	145 (65.8)	264 (119.8)	12 (5.4)	79/100 (35.8/45.4)	31 (14.06)	88 (40)	2 (.9)	9 (4)	12 (5.4)	6 (2.7)

Note:
1. For use when no heat is supplied.
2. For use with electric heat.

Mechanical Specifications

Heat Pumps

General

Unit shall be assembled on heavy gauge steel mounting/lifting rails and shall be weather proofed. Unit shall include a hermetic scroll or reciprocating compressor(s), plate fin condenser coil, fans and motors, controls, and holding charge of nitrogen. Operating Range shall be between 115° F and 35° F in cooling as standard from factory. Unit shall be UL 1995 listed and rated in accordance with ARI Standard 210/240 or 340/360.

Casing

Unit casing shall be constructed of zinc coated, heavy gauge, galvanized steel. Exterior surfaces shall be cleaned, phosphatized, and finished with a weather-resistant baked enamel finish. Unit's surface shall be tested 500 hours in salt spray test. Unit shall have removable end panels which allow access to all major components and controls.

Refrigeration System — Single Compressor

TWA075A, TWA100A units shall have a single refrigeration circuit. Each refrigeration circuit has an integral subcooling circuit. A refrigeration filter drier, expansion valve, and check valves shall be provided as standard. The unit shall have both a liquid line and suction gas line service valve with gauge port.

Unit shall have one direct drive, Trane hermetic scroll compressor with centrifugal oil pump providing positive lubrication to moving parts. Motor shall be suction gas-cooled and shall have a voltage utilization range of plus or minus 10 percent of nameplate voltage. Crankcase heater, discharge line thermostat, and current-sensitive motor overloads shall be included for maximum protection. Scroll type compressor shall provide inherently low vibration and noise by having no suction and discharge valves. External high and low pressure cutout devices shall be provided. Evaporator defrost control provided in indoor blower coil unit shall prevent compressor slugging by temporarily interrupting compressor operation when low evaporator coil temperatures are encountered.

Refrigeration System — Dual Compressor

TWA155B, TWA200B units shall have two separate and independent refrigeration circuits. Each refrigeration circuit shall have an integral subcooling circuit. A refrigeration filter drier shall be provided as standard. Unit shall have both a liquid line and suction gas line service valve with gauge ports.

Unit shall have two Trane direct drive, hermetic scroll compressors with centrifugal oil pump and provide positive lubrication to all moving parts. Motor shall be suction gas-cooled and shall have a voltage utilization range of plus or minus 10 percent of nameplate voltage. Crankcase heater, discharge line thermostat, and current-sensitive motor overloads shall be included for maximum protection. Scroll type compressor shall provide inherently low vibration and noise by having no suction and discharge valves. External high and low pressure cutout devices shall be provided. Evaporator defrost control provided in indoor blower coil shall prevent compressor slugging by temporarily interrupting compressor operation when low evaporator coil temperatures are encountered.

Condenser Coil

Coils shall be internally finned or smooth bore, 3/8" (10mm) copper tubes mechanically bonded to a configured aluminum plate fin as standard. Coil shall be factory pressure and leak tested to 420 psig (2,930 kPa) air pressure. Metal grilles with PVC coating for coil protection is optional.

Condenser Fan And Motor(s)

Direct-drive, statically and dynamically balanced, 26 or 28 inch (660 or 711 mm) propeller fan(s) with aluminum blades and electro-coated steel hubs shall be used in draw-through vertical discharge position. Either permanently lubricated totally enclosed or open construction type motors shall be provided and shall have built-in current and thermal overload protection. Motor(s) shall have either ball or sleeve bearing type.

Controls

Heat pump units shall be completely factory wired with necessary controls and contactor pressure lugs or terminal

block for power wiring. Control wiring shall be 24-volt control circuit which includes fusing and control transformer. Units shall provide external location for mounting a fused disconnect device. Time delay timers to prevent compressors in dual compressor units from simultaneous start-up and anti-recycle timers are available as optional accessories.

Defrost Controls

Electronic timed initiated, temperature terminated defrost system with choice of 50, 70, or 90 minute cycle shall be included. Timed override limits defrost cycle to 10 minutes.

Low Ambient Operation

Standard units shall start and operate to approximately 35° F (1.7° C) when matched with Trane air handlers and coils. Optional head pressure control accessory permits operation to 0° F (-17.8° C).

ACCESSORIES

Low Ambient Head Pressure Control —

This accessory shall modulate the RPM of unit outdoor fan motor in response to outdoor ambient temperatures and liquid line temperature. Accessory provides unit cooling operation to outdoor temperatures of 0° F (-17.8° C).

Vibration Isolation Packages - This accessory shall reduce transmission of noise and vibration to building structures, equipment, and adjacent spaces. Packages shall be available in either neoprene-in-shear or spring-flex types.

Time Delay Relay — This accessory shall prevent compressors in dual compressor unit from coming on line simultaneously. Timer shall be 24-volt, 60 cycle, with four minute timing period.

Anti-Short-Cycle Timer — This accessory shall prevent rapid on-off compressor cycling in light load conditions by not allowing compressor to operate for 5-7 minutes upon shutdown. This accessory shall consist of a 24-volt, 60 cycle, solid state timing device with either 5 or 7 minute fixed-off timing period.



Mechanical Specifications

Condenser Coil Guard — Metal grille with PVC coating shall be provided to alleviate coil damage.

Black Epoxy Coated Condenser Coil — This factory installed option is designed to provide corrosion protection of air cooled condenser coils for seacoast application. The black epoxy coil protection is a factory applied thermoset vinyl coating, bonded to normal aluminum fin stock. The uniform thickness of the bonded vinyl layer exhibits excellent corrosion protection in salt spray tests performed in accordance with ASTM B177.

Air Handlers

General

Air handler units shall be completely factory assembled including coil, condensate drain pan, fan motor(s), filters, and controls in an insulated casing that can be applied in either vertical or horizontal configuration. Unit shall be rated and tested in accordance with ARI standard 210/240 or 340/360. Unit shall be UL listed and labeled in accordance with UL 1995 for indoor blower coil units.

Casing

Unit casing shall be constructed of zinc coated, heavy gauge, galvanized steel. Exterior surfaces shall be cleaned, phosphatized, and finished with a weather-resistant baked enamel finish. Casing shall be completely insulated with cleanable, foil faced, fire-retardant, permanent, odorless, glass fiber material. All insulation edges shall be either captured or sealed. Knockouts shall be provided for unit electrical power and refrigerant piping connections. Captive screws shall be standard on all access panels.

Refrigeration System

The TWE050A, TWE075A, TWE100A units shall have a single refrigeration circuit and the TWE100B, TWE155B, TWE200B units shall have dual refrigeration circuits. Each refrigeration circuit is controlled by a factory installed thermal expansion valve.

Evaporator Coil

Configured aluminum fin surface shall be mechanically bonded to 3/8" (10 mm)

internally enhanced copper tubing and shall be factory pressure and leak tested at 375 psig (2586 kPa). Coil is arranged for draw-through airflow and shall provide a double sloped condensate drain pan constructed of PVC plastic. The drain pan shall be removable for cleaning. The condensate drain pan can be installed in any of four positions allowing for vertical or horizontal application and providing external connections on either side of the unit.

Evaporator Fan

Double inlet, double width, forward curved, centrifugal-type fan(s) with adjustable belt drive shall be standard. Thermal overload protection shall be standard on motor. Fan and motor bearings shall be permanently lubricated. Oversized motors shall be available as an option for high static application. All indoor fan motors meet the U.S. Energy Policy Act of 1992 (EPACT).

Controls

Magnetic evaporator fan contactor, low voltage terminal strip, check valve(s), and single point power entry shall be included. All necessary controls shall be factory-installed and wired. Evaporator defrost control shall be included to prevent compressor slugging by temporarily interrupting compressor operation when low evaporator coil temperatures are encountered.

Filters

One inch, throw-away filters shall be standard on TWE050A, TWE075A, TWE100A and TWE120B model air handlers. Filters shall be accessible from the side coil access panel. Filter rack can be field converted to two inch capability. Two inch, throw-away filters shall be standard on TWE155B and TWE200B models.

ACCESSORIES

Electric Heaters — UL and CSA approved electric heat modules shall be available for installation directly on fan discharge. Electric heaters shall be available in a wide range of capacities with one or two stage control, single-point electric power connection, and terminal strip connections. Electric heater elements shall be constructed of heavy-duty nickel chromium elements

internally wye connected on 400 volt, three phase. Each 400 volt heater shall have automatic line break high limit controls.

Discharge Plenums and Grilles

Accessory discharge plenums shall be available for vertical, free discharge applications. Plenums shall be constructed of heavy-gauge, zinc coated, galvanized steel finished with baked enamel to match the air handler unit. Grilles shall be satin finished aluminum and have four-way adjustable louvers.

Return Air Grilles — Accessory return air grille shall be provided for vertical front, free return applications. Grilles shall be installed in place of the front lower side panel. Grille shall be satin finished aluminum with non-adjustable louvers.

Mounting Subbase — The accessory shall be available for vertical floor mount configurations. Subbase shall be constructed of heavy gauge, zinc coated, galvanized steel with baked enamel finish to match air handler unit. Subbase is required in the vertical air flow application for condensate drain trapping and when isolators are required.

Vibration Isolators — This accessory shall reduce transmission of noise and vibration to building structures, equipment, and adjacent spaces. Packages shall be available in either neoprene-in shear or spring-flex types in floor or suspended mountings.

Oversized Motors — Field installed oversized motors shall be available for high static pressure applications.

CONTROL OPTIONS

Standard Indoor Thermostats — Two stage heating and cooling operation or one stage heating and cooling thermostats shall be available in either manual or automatic changeover.

Programmable Electronic Night Setback Thermostat — The option shall provide heating setback and cooling setup with 7-day programming capability.

Outdoor Thermostat — This option shall provide staging control of electric heaters based on a set outdoor temperature.



TRANE®

The Trane Company
An American Standard Company
www.trane.com

For more information contact your
local office or e-mail us at
comfort@trane.com

Literature Order Number	SSP-PRC002-EN
File Number	PL-UN-SSP-PRC002-EN-1003
Supersedes	TWA-PRC001-EN 1101
Stocking Location	October Publication Electronic Only

Since The Trane Company has a policy of continuous product and product data improvement, it reserves the right to change design and specifications without notice.

Free Manuals Download Website

<http://myh66.com>

<http://usermanuals.us>

<http://www.somanuals.com>

<http://www.4manuals.cc>

<http://www.manual-lib.com>

<http://www.404manual.com>

<http://www.luxmanual.com>

<http://aubethermostatmanual.com>

Golf course search by state

<http://golfingnear.com>

Email search by domain

<http://emailbydomain.com>

Auto manuals search

<http://auto.somanuals.com>

TV manuals search

<http://tv.somanuals.com>