



# Packaged Heat Pumps

---

Precedent™  
WSC060-120  
50 Hz



---

January 2003

PKGP-PRC004-EN



# Introduction

---



Precedent™...The same Trane quality...with added flexibility. Precedent is a flexible line of packaged units that cover a wide variety of applications.

ReliaTel™ microprocessor controls provide superior flexibility for the simplest to the most sophisticated applications. In addition to controls, Precedent offers many other outstanding features and option choices.

With its sleek compact cabinet, rounded corners and beveled top, it may just be the most aesthetically pleasing packaged unit on the planet. And, of course, Precedent carries the Trane reputation for excellence, quality and reliability. *It's hard to stop a Trane.*

From simple applications, to the most complex, Precedent has the solution.

# Contents

---

<b>Introduction</b>	<b>2</b>
<b>Features and Benefits</b>	<b>4</b>
<b>Application Considerations</b>	<b>9</b>
<b>Selection Procedure</b>	<b>10</b>
<b>Model Number Description</b>	<b>12</b>
<b>General Data</b>	<b>13</b>
<b>Performance Data</b>	<b>14</b>
<b>Controls</b>	<b>34</b>
<b>Electrical Data</b>	<b>35</b>
<b>Jobsite Connections</b>	<b>38</b>
<b>Dimensional Data</b>	<b>39</b>
<b>Weights</b>	<b>46</b>
<b>Mechanical Specifications</b>	<b>47</b>



# Features and Benefits



### Unit Cabinet

The compact cabinet with rounded corners takes up less room and is less costly to ship. The beveled and ribbed top is not only aesthetically pleasing, it is designed to prevent water from pooling.

### Single Point Power

A single electrical connection powers the unit.



### Compressors

Precedent™ contains the best compressor technology available to achieve the highest possible performance. Our compressor line includes Trane-built Climatuff™ reciprocating and scrolls.

### Easy Access Panels

Easy access panels reduce the number of possible water entry points. Remove two screws for access to the standardized internal components and wiring.

### Low Ambient Cooling

All Precedent units have cooling capabilities down to -18° C (0° F) as standard.

### Easy-Adjust Idler Arm

With the Easy-Adjust Idler Arm, the belt and sheaves can be quickly adjusted without moving the mounted fan motor. The result is a major savings in time and money.

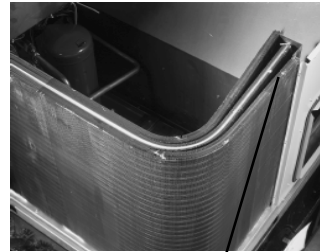
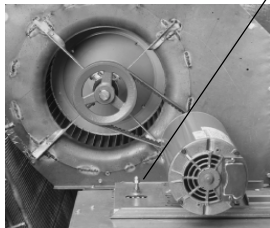

### Patented Condenser Coil

Precedent boasts a patented 1+1+1 Hybrid coil, permanently gapped for easy cleaning.

### Colored And Numbered Wiring

You save time and money tracing wires and diagnosing the unit.

### Convertible Units

- The units ship in a downflow configuration. They can be easily converted to horizontal by simply moving two panels.
- Units come complete with horizontal duct flanges so the contractor doesn't have to field fabricate them. These duct flanges are a time and cost saver.



### Unit Base

For added water integrity, Precedent has a raised 29 mm (1<sup>1</sup>/<sub>8</sub>" ) lip around the unit's downflow supply and return to prevent water from blowing into the ductwork.

### Sloped Drain Pans

Every Precedent unit has a non-corrosive, removable, double-sloped drain pan that's easy to clean and reversible to allow installation of drain trap on either side of the unit.

### Through the Base Condensate

Every unit includes provisions for through the base condensate drain connections. This allows the drain to be connected through the roof curb instead of a roof penetration.

### Foil-Faced Insulation

All panels in the Evaporator section of the unit have cleanable foil-faced insulation. All edges are either captured or sealed to ensure no fibers get into the airstream.

# Features and Benefits

---

## Standardized Components

- Components are placed in the same location on all Precedent® units. Familiarize yourself with one Precedent and you are familiar with every Precedent.

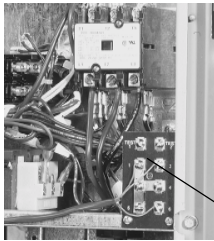

## Easy Access Low Voltage Terminal Board

Precedent's Low Voltage Terminal Board is external to the electrical control cabinet. It is extremely easy to locate and attach the thermostat wire. This is another cost and time saving installation feature.

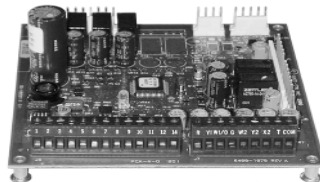

## Low Voltage Connections

The wiring of the low voltage connections to the unit and the zone sensors is as simple as 1-1, 2-2, and 3-3. This simplified system makes it easy for the installer to wire.

## Single-Side Service

Single-side service is standard on all Precedent units.

## Flexible Applications

- Only two roof curbs for the 5-10 ton Precedent line... simplifies curb selection.
- Airflow is outstanding. The Precedent can replace an older machine with old ductwork and, in many cases, improve comfort through better air distribution.
- Belt drive – standard or oversized supply fan motors meet a wide airflow range.
- Precedent offers ultimate flexibility. Options and components are not pre-packaged at the factory. Units are built to order in our standard "shortest in the industry" ship cycle time.

# Features and Benefits

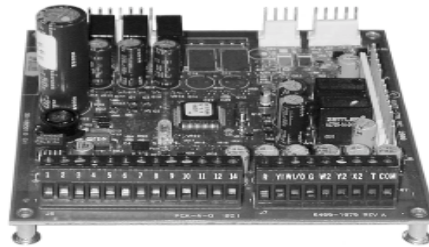

## Micro Controls

Several years ago, Trane was the first to introduce microprocessor controls into the Light Commercial Market. That design, along with immeasurable experience, has provided the technology for Trane's second-generation ReliaTel™ microprocessor controls.

### ReliaTel Micro:

- Provides unit control for heating, cooling, and ventilating by utilizing input from sensors that measure outdoor and indoor temperature.
- Improves quality and reliability through the use of time-tested microprocessor controls and logic.
- Prevents the unit from short cycling, considerably improving compressor life.
- Ensures that the compressor will run for a specific amount of time, which allows oil to return for better lubrication, enhancing the reliability of the compressor.
- Reduces the number of components required to operate the unit, thereby reducing possibilities for component failure.

- Eliminates the need for field-installed components with its built-in anti-short-cycle timer, time delay relay and minimum "on" time controls. These controls are factory tested to assure proper operation.
- Requires no special tools to run the Precedent unit through its paces during testing. Simply place a jumper between Test 1 and Test 2 terminals on the Low Voltage Terminal Board and the unit will walk through its operational steps. The unit automatically returns control to the zone sensor after stepping through the test mode a single time, even if the jumper is left on the unit.
- As long as the unit has power and the LED is lit, the Micro is operational. The light indicates that the Micro is functioning properly.
- Features expanded diagnostic capabilities when used with Trane's Integrated Comfort™ systems.
- As an energy benefit, softens electrical "spikes" by staging on fans, compressors and heaters.
- The Intelligent Fallback or Adaptive Control is a benefit to the building occupant. If a component goes astray, the unit will continue to operate at predetermined temperature set points.
- Intelligent Anticipation is a standard feature of the Micro. Functioning constantly, the Micro and zone sensors work together in harmony to provide tight comfort control.

# Features and Benefits

## Factory-installed Options

### Hinged Access Doors

These doors permit easy access to the filter, fan/heat, and compressor/control sections. They reduce the potential roof damage from screws or sharp access door corners.

### Economizer

Equipped with either dry bulb, reference or comparative enthalpy sensing, this feature provides free cooling as the outdoor temperature and/or humidity decreases. Economizers, correctly installed, offer valuable energy savings. Factory-installed economizers save time and ensure proper installation.

### Clogged Filter/Fan Fail Switches

These sensors allow a zone sensor service light or Integrated Comfort system to indicate a dirty filter or a fan that's not working. The field installation charges for these valuable feedback devices often eliminate them from consideration. Factory installation can make such features a good investment.

### Comm-3/4 Trane Communication Interface

Available factory or field-installed. This module, when applied with the Micro, easily interfaces with Trane's Integrated Comfort® system.



The following options round-out the complete line of Precedent™ options:

- 0 - 50% Manual or Motorized Outside Air
- Discharge Air Sensor
- Electric heaters (available as field-installed accessories)
- Hail Protection Quality Coil Guards
- Wide array of Zone Sensors
- Factory built Roof Curb

### One of Our Finest Assets:

Trane Sales Representatives are a Support group that can assist you with:

- Product
- Application
- Service
- Training
- Special Applications
- Specifications
- Computer Programs and much more

Precedent has the features and benefits that make it first class in the light commercial rooftop market. Designed with input from field contractors and engineers, its airflow performance is outstanding.

**Precedent. The same Trane quality. with added flexibility.**

# Features and Benefits

## Quality And Reliability Testing

- All Precedent® designs were rigorously rain tested at the factory to ensure water integrity.
  - Actual shipping tests were performed to determine packaging requirements. Units were test shipped around the country to determine the best packaging.
  - Factory shake and drop tests were used as part of the package design process to help assure that the unit arrives at the job site in top condition.
  - Rigging tests include lifting a unit into the air and letting it drop one foot, assuring that the lifting lugs and rails hold up under stress.
- We perform a 100% coil leak test at the factory. The evaporator and condenser coils are leak tested at 1,375 kPa (200 psig) and pressure tested to 3,100 kPa (450 psig).
  - All parts are inspected at the point of final assembly. Sub-standard parts are identified and rejected immediately.
  - Every unit receives a 100% unit run test before leaving the production line to make sure it lives up to rigorous Trane requirements.

**We test designs at our factory not on our customers!**

## VariTrac™

### VariTrac™

When Trane's changeover VAV System for light commercial applications is coupled with Precedent, it provides the latest in technological advances for comfort management systems and can allow thermostat control in every zone served by VariTrac.

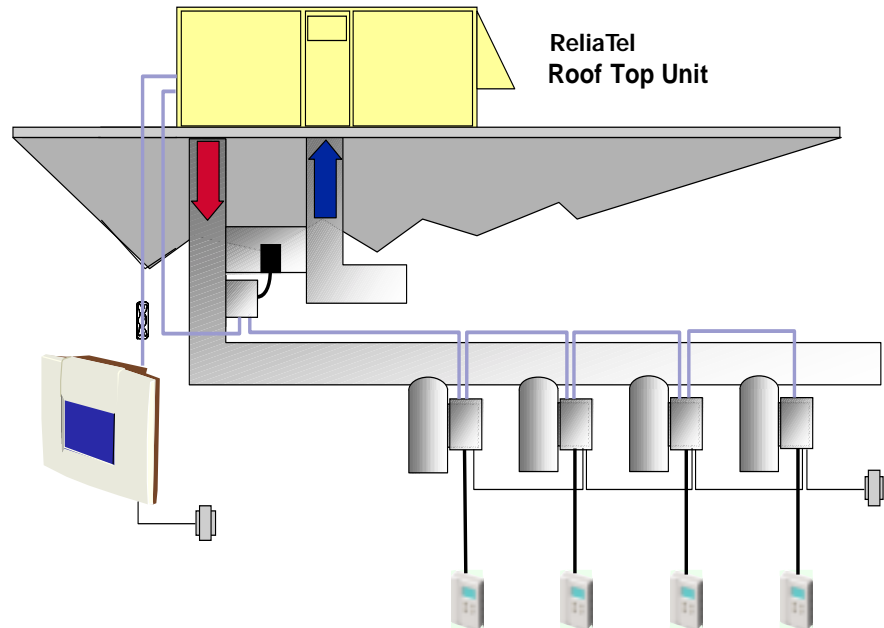



# Application Considerations

---

Application of this product should be within the cataloged airflow and cooling considerations.

## **Low Ambient Cooling**

Precedent™ features, as standard, low ambient cooling down to -18°C (0°F). Contact your local Trane Representative for more assistance with low ambient cooling applications.

## **Barometric Relief**

This product line offers an optional barometric relief damper for use in conjunction with economizer option. This option consists of gravity dampers which open with increased pressure. As the building air pressure increases, the pressure in the unit return air section also increases, opening the dampers and relieving the conditioned space.

NOTE: THE EFFECTIVENESS OF BAROMETRIC RELIEF DAMPER DURING ECONOMIZING OPERATION IS SYSTEM RELATED.

PRESSURE DROP OF THE RETURN AIR SYSTEM SHOULD BE CONSIDERED TO CONTROL BUILDING PRESSURIZATION.

## **Condensate Trap**

The evaporator is a draw-thru configuration. A trap must be field provided prior to start-up on the cooling cycle.

## **Clearance Requirements**

The recommended clearances identified with unit dimensions should be maintained to assure adequate service, maximum capacity and peak operating efficiency. Actual clearances which appear inadequate should be reviewed with the local Trane sales personnel.

## **Unit Pitch**

These units have reversible sloped condensate drain pans. Units must be installed level, any unit slope must be toward side of unit where condensate drain is connected.

# Selection Procedure - SI Units

## Cooling Capacity

### Step 1

Calculate the building's total and sensible cooling loads at design conditions. Use the Trane calculation form or any other standard accepted method.

### Step 2

Size the equipment using Table PD-1. Match the cooling loads at design conditions. Example: The following are the building cooling requirements:

#### A

Electrical Characteristics: 380- 415/50/3

#### B

Summer Design Conditions:  
Entering Evaporator Coil: 27 DB/ 19 WB  
Outdoor Ambient: 35

#### C

Total Cooling Load: 17.0 kW

#### D

Sensible Cooling Load: 11.7 kW

#### E

Airflow: 3,400 m<sup>3</sup>/hr  
External Static Pressure: 130 Pa

#### F

Downflow Configuration

Table PD-1 shows that a WSC060AD has a gross cooling capacity of 18.1 kW and 14.7 kW sensible capacity at 35 degree C ambient and 3,400 m<sup>3</sup>/hr with 27 DB/19 WB air entering the evaporator.

To find the net cooling capacities, fan motor heat must be subtracted.

Determine the total unit static pressure:

External Static	130 Pa
Standard Filter 1 in.	37 Pa
Economizer	46 Pa
Supplementary Electric Heat	21 Pa
Total Static Pressure	234 Pa

Note: The Evaporator Fan Performance Table PD-9 has deducted the pressure drop for a 25 mm filter already in the downflow unit.

Therefore, the actual Total Static Pressure is 234 - 37 = 197 Pa. With 3,400 m<sup>3</sup>/hr and 197 Pa, Table PD-9 shows 0.75 kW.

Note below the table gives a formula to calculate Fan Motor Heat,

Fan Motor Heat (kW) =  
 $1.144 \times (\text{Fan kW}) + 0.132$   
 $= 1.144 \times 0.75 + 0.132 = 1.0 \text{ kW}$

Net Total Cooling Capacity =  
 $18.1 - 1.0 = 17.1 \text{ kW}$

Net Sensible Cooling Capacity =  
 $14.7 - 1.0 = 13.7 \text{ kW}$

## Heating Capacity

### Step 1

Calculate the building heating load using the Trane calculation form or other standard accepted method.

### Step 2

Size the equipment using Table PD-5 to match the heating loads at design conditions.

#### A

Total Heating Load: 16 kW

#### B

Outdoor Ambient (Winter) - 9°C DB

#### C

Indoor Return Temperature: 21°C DB

#### D

Airflow: 3,400 m<sup>3</sup>/hr

Use the portion of Table PD-5 for the WSC060AD to determine capacity at winter design conditions. The mechanical heating portion of the heat pump will provide 8.3 kW.

### Step 3

Because 8.3 kW is less than the building's required heating capacity at winter design conditions, a supplementary heater must be selected.  
 $16 \text{ kW} - 8.3 \text{ kW} = 7.7 \text{ kW}$

From Table PD-9, at 380 volts, the 10.9 kW Heater will be adequate to do the job.

10.9 kW 38.0 MBh

From Table ED-5 select heater BAYHTRR418A (10.9 kW 380/50/3).

### Air Delivery Selection

External static pressure drop through the air distribution system has been calculated to be 200 Pa. Enter Table PD-9 for a WSC060AD at 3400 m<sup>3</sup>/h and 200 Pa static pressure. The standard motor will give the desired airflow.

### Accessory Selection

Select accessories needed to accommodate the application.

# Selection Procedure - IP Units

## Cooling Capacity

### Step 1

Calculate the building's total and sensible cooling loads at design conditions. Use the Trane calculation form or any other standard accepted method.

### Step 2

Size the equipment using Table PD-1a. Match the cooling loads at design conditions.

Example: The following are the building cooling requirements:

#### A

Electrical Characteristics: 380- 415/50/3

#### B

Summer Design Conditions:  
Entering Evaporator Coil: 80 DB/ 67 WB  
Outdoor Ambient: 95

#### C

Total Cooling Load: 53 MBh

#### D

Sensible Cooling Load: 33 MBh

#### E

Airflow: 2,000 cfm  
External Static Pressure: .52 in. w.g.

#### F

Downflow Configuration

Table PD-1a shows that a WSC060AD has a gross cooling capacity of 59.0 MBh and 45.7 MBh sensible capacity at 95 degree ambient and 2,000 cfm with 80 DB/67 WB air entering the evaporator.

To find the net cooling capacities, fan motor heat must be subtracted.

Determine the total unit static pressure:

External Static	0.52 in.
Standard Filter 1 in.	0.15 in.
Economizer	0.18 in.
Supplementary Electric Heat	0.083 in.
Total Static Pressure	0.933 in.

Note: The Evaporator Fan Performance Table PD-9a has deducted the pressure drop for a 1 in. filter already in the downflow unit.

Therefore, the actual Total Static Pressure is  $0.933 - 0.15 = 0.78$ . With 2,000 cfm and 0.78 inches, Table PD-9a shows 1.00 bhp.

Note below the table gives a formula to calculate Fan Motor Heat,

$$\begin{aligned} \text{Fan Motor Heat (MBh)} &= \\ &2.915 \times (\text{Fan bhp}) + 0.451 \\ &= 2.915 \times 1.00 + 0.451 = 3.37 \text{ MBh} \end{aligned}$$

$$\begin{aligned} \text{Net Total Cooling Capacity} &= \\ 57 - 3.37 &= 53.6 \text{ MBh} \end{aligned}$$

$$\begin{aligned} \text{Net Sensible Cooling Capacity} &= \\ 38 - 3.37 &= 34.6 \text{ MBh} \end{aligned}$$

## Heating Capacity

### Step 1

Calculate the building heating load using the Trane calculation form or other standard accepted method.

### Step 2

Size the equipment using Table PD-5a to match the heating loads at design conditions.

#### A

Total Heating Load: 50 MBh

#### B

Outdoor Ambient (Winter) 17 DB

#### C

Indoor Return Temperature: 70 DB

#### D

Airflow: 2,000 cfm

Use the portion of Table PD-5a for the WSC060AD to determine capacity at winter design conditions. The mechanical heating portion of the heat pump will provide 29.1 MBh.

### Step 3

Because 29.1 MBh is less than the building's required heating capacity at winter design conditions, a supplementary heater must be selected.  
 $50 \text{ MBh} - 29.1 \text{ MBh} = 20.9 \text{ MBh}$

From Table PD-9a, at 380 volts, the 38.0 MBh Heater will be adequate to do the job.

$$10.9 \text{ kW} \quad 38.0 \text{ MBh}$$

From Table ED-2 select heater BAYHTRR418A (38.0 MBh at 380 volts).

### Air Delivery Selection

External static pressure drop through the air distribution system has been calculated to be 0.80 inches of water. Enter Table PD-9a for a WSC060AD at 2000 cfm and 0.80 static pressure. The standard motor will give the desired airflow.

### Accessory Selection

Select accessories needed to accommodate the application.



# Model Number Description

W S C 060 A D R 0 A \*\* C 0 0 0 0 0 0 0 0 1  
 1 2 3 4,5,6 7 8 9 10 11 12,13 14 15 16 17 18 19 20 21 22 23 24 25

**Digit 1 - Unit Function**  
 W = Packaged Heat Pump

**Digit 2 - Efficiency**  
 S = Standard Efficiency

**Digit 3 - Airflow**  
 C = Convertible

**Digits 4,5,6 - Nominal Gross Cooling Capacity (MBh)**

	<u>kW</u>	<u>Tons</u>
060 =	17.6	5
072 =	21.1	6
090 =	26.4	7.5
120 =	35.1	10

**Digit 7 - Major Design Sequence**  
 A = First

**Digit 8 - Unit Voltage**  
 D = 380-415/50/3  
 T = 200/50/3

**Digit 9 - Unit Controls**  
 R = ReliaTel® Microprocessor

**Digit 10 - Electric Heater**  
 0 = No Electric Heater

**Digit 11 - Minor Design Sequence**  
 A = First Sequence

**Digits 12,13 - Service Sequence**  
 \*\* = Factory Assigned

**Digit 14 - Fresh Air Selection**  
 0 = No Fresh Air  
 A = Manual Outside Air Damper 0-50%  
 B = Motorized Outside Air Damper 0-50%  
 C = Economizer, Dry Bulb 0-100% without Barometric Relief  
 D = Economizer, Dry Bulb 0-100% with Barometric Relief  
 E = Economizer, Reference Enthalpy 0-100% without Barometric Relief  
 F = Economizer, Reference Enthalpy 0-100% with Barometric Relief  
 G = Economizer, Comparative Enthalpy 0-100% without Barometric Relief  
 H = Economizer, Comparative Enthalpy 0-100% with Barometric Relief

**Digit 15 - Supply Fan/Drive Type/Motor**  
 0 = Standard Drive  
 1 = Oversized Motor

**Digit 16 - Hinged Service Access/Filters**  
 0 = Standard Panels/Standard Filters  
 A = Hinged Access Panels/Standard Filters  
 B = Standard Panels/50mm (2") Pleated Filters  
 C = Hinged Access Panels/50mm (2") Pleated Filters

**Digit 17 - Condenser Coil Protection**  
 0 = Standard Coil  
 1 = Standard Coil with Hail Guard  
 2 = Epoxy Coated Condenser Coil  
 3 = Epoxy Coated Condenser Coil with Hail Guard

**Digit 18 - Through the Base Provisions**  
 0 = No Through the Base Provisions

**Digit 19 - Disconnect/Circuit Breaker**  
 0 = No Disconnect or Circuit Breaker

**Digit 20 - Convenience Outlet**  
 0 = No Convenience Outlet

**Digit 21 - Communications Options**  
 0 = No Communications Interface  
 1 = Comm-3/4 Trane Communications Interface  
 2 = Comm-5 LonTalk Communications Interface

**Digit 22 - Refrigeration System Option**  
 0 = Standard Refrigeration System

**Digit 23 - Refrigeration Controls**  
 0 = No Refrigeration Control

**Digit 24 - Smoke Detector**  
 0 = No Smoke Detector

**Digit 25 - Monitoring Controls**  
 0 = No Monitoring Control  
 1 = Clogged Filter Switch  
 2 = Fan Failure Switch  
 3 = Discharge Air Sensing Tube  
 4 = Clogged Filter Switch and Fan Fail Switch  
 5 = Clogged Filter Switch and Discharge Air Sensing Tube  
 6 = Fan Fail Switch and Discharge Air Sensing Tube  
 7 = Clogged Filter and Fan Fail Switches and Discharge Air Sensing Tube

# General Data

**Table GD-1 - General Data**

	Convertible Units WSC060AD,T	Convertible Units WSC072AD,T	Convertible Units WSC090AD,T	Convertible Units WSC120AD,T
<b>Cooling Performance</b> <sup>1</sup>				
Gross Capacity - kW (MBh)	17.3 (59.0)	22.6 (77.0)	27.8 (95.0)	34.6 (118.0)
COP (EER) <sup>2</sup>	2.72 (9.3)	3.31 (11.3)	3.20 (10.9)	3.28 (10.1)
Nominal Airflow - m <sup>3</sup> /h (cfm)	3400 (2000)	4080 (2400)	5100 (3000)	6800 (4000)
Rated Airflow - m <sup>3</sup> /h (cfm)	3400 (2000)	3570 (2100)	4460 (2625)	5950 (3500)
Net Capacity - kW (MBh)	16.7 (57.0)	21.4 (73.0)	26.4 (90.0)	33.1 (113.0)
System Power - kW	6.13	6.46	8.26	11.19
<b>Heating Performance</b> <sup>1</sup>				
High Temperature Capacity - kW (MBh)	16.0 (54.5)	19.9 (68.0)	24.0 (82.0)	31.9 (109.0)
COP	3.40	3.45	3.54	3.36
System Power - kW	4.71	5.76	6.78	9.48
<b>Compressor</b>				
Number - Type	1-Climatuff Scroll	1-Climatuff Scroll	1-Trane 3-D Scroll	2-Climatuff Scroll
<b>Outdoor Sound Rating - dB</b> <sup>3</sup>				
	80	85	85	79
<b>Outdoor Coil - Type</b>				
	Lanced	Lanced	Lanced	Lanced
Tube Size - in. OD	0.3125	0.3125	0.3125	0.3125
Face Area - m <sup>2</sup> (sq ft)	1.02 (10.96)	1.58 (17.00)	1.58 (17.00)	1.84 (19.83)
Rows / FPI	3 / 17	2 / 17	3 / 17	3 / 17
Refrigerant Control	Expansion Valve	Expansion Valve	Expansion Valve	Expansion Valve
<b>Indoor Coil - Type</b>				
	Lanced	Lanced	Lanced	Lanced
Tube Size OD - in.	0.3125	0.3125	0.3125	0.3125
Face Area - m <sup>2</sup> (sq ft)	0.72 (7.71)	0.92 (9.89)	0.92 (9.89)	1.15 (12.36)
Rows / FPI	3 / 16	3 / 16	4 / 16	4 / 16
Refrigerant Control	Short Orifice	Short Orifice	Short Orifice	Short Orifice
Drain Connection No. / Size - in.	1 / 0.75 NPT	1 / 0.75 NPT	1 / 0.75 NPT	1 / 0.75 NPT
<b>Outdoor Fan - Type</b>				
	Propeller	Propeller	Propeller	Propeller
No. Used / Diameter (in.)	1 / 22	1 / 26	1 / 26	1 / 26
Drive Type / No. Speeds	Direct / 1	Direct / 1	Direct / 1	Direct / 1
CFM	2900	5100	5200	5800
No. Motors / kW (HP)	1 / 0.30 (0.40)	1 / .56 (0.75)	1 / .56 (0.75)	1 / .56 (0.75)
Motor RPM	950	950	950	950
<b>Belt Drive Indoor Fan - Type</b>				
	FC Centrifugal	FC Centrifugal	FC Centrifugal	FC Centrifugal
No. Used	1	1	1	1
Fan Diameter x Width - mm - in.	280 X 280 (11 x 11)	305 X 305 (12 x 12)	305 X 305 (12 x 12)	(381 X 381) 15 x 15
Drive Type / No. Speeds	Belt / Variable Speed	Belt / Variable Speed	Belt / Variable Speed	Belt / Variable Speed
No. Motors	1	1	1	1
Standard Motor Power - kW (HP)	1.1 (1.5)	1.1 (1.5)	1.5 (2.0)	2.2 (3.0)
Oversized Motor Power - kW (HP)	-	1.5 (2.0)	2.2 (3.0)	-
Motor RPM - Standard / Oversized	1450 / -	1450 / 1450	1450 / 2850	2850 / -
Motor Frame Size	56	56	56	56
<b>Filters - Type Furnished</b>				
	Throwaway	Throwaway	Throwaway	Throwaway
(No.) Size Recommended - mm	(2) 508 X 762 X 25	(4) 406 X 635 X 50	(4) 406 X 635 X 50	(4) 508 X 635 X 50
(No.) Size Recommended - in.	(2) 20 X 30 X 1	(4) 16 X 25 X 2	(4) 16 X 25 X 2	(4) 20 X 25 X 2
<b>Refrigerant Charge - kg (lbs) of R-22</b> <sup>4</sup>				
	3.6 (8.0)	4.3 (9.4)	5.7 (12.5)	Circuit 1 - 3.5 (7.7) Circuit 2 - 3.5 (7.7)

**NOTES:**

- Cooling Performance is rated at 35.0 C (95 F) ambient, 26.7 C (80 F) entering dry bulb, 19.4 C (67 F) entering wet bulb. Heating Performance is rated at 20.0 C (68 F) ambient, 8.3 C (47 F) entering dry bulb, 6.1 C (43 F) entering wet bulb. Gross capacity does not include the effect of fan motor heat. Net capacity includes the effect of fan motor heat. Units are suitable for operation to  $\pm 20\%$  of nominal airflow.
- EER are rated at ARI conditions.
- Outdoor Sound rating shown is tested in accordance with ARI Standard 270. For more information refer to Performance Data Table "Sound Power Level".
- Refrigerant charge is an approximate value. For a more precise value, see unit nameplate and service literature.



# Performance Data

**Table PD-1 – Gross Cooling Capacities (kW) WSC060AD,T (SI)**

m³/h Airflow	Enter. Dry Bulb Temp (C)	Ambient Temperature (C)																							
		30						35						40						45					
		Entering Wet Bulb Temperature (C)																							
		16		19		22		16		19		22		16		19		22		16		19		22	
		TGC	SHC	TGC	SHC	TGC	SHC	TGC	SHC	TGC	SHC	TGC	SHC	TGC	SHC	TGC	SHC	TGC	SHC	TGC	SHC	TGC	SHC		
3060	24	14.5	13.2	16.6	10.7	18.3	7.6	15.6	13.8	17.7	11.0	19.0	8.0	13.3	12.6	15.3	10.1	17.4	7.2	12.1	12.0	13.9	9.5	16.3	6.6
	27	15.3	15.3	16.7	13.4	18.4	10.4	16.3	16.3	17.8	13.9	19.1	10.8	14.3	14.3	15.4	12.8	17.5	10.0	13.3	13.3	14.1	12.2	16.3	9.5
	30	16.7	16.7	17.0	16.3	18.5	13.2	17.6	17.6	18.0	16.8	19.3	13.4	15.7	15.7	15.8	15.8	17.5	12.8	14.7	14.7	14.7	14.7	16.4	12.3
	33	17.9	17.9	17.9	17.9	18.7	15.9	18.6	18.6	18.6	18.6	19.5	16.0	17.0	17.0	17.0	17.0	17.7	15.6	16.0	16.0	16.0	16.0	16.6	15.2
3400	24	14.9	14.1	16.9	11.3	18.5	7.8	16.1	14.7	18.0	11.5	19.2	8.2	13.7	13.5	15.6	10.4	17.6	7.4	12.5	12.5	14.2	10.1	16.5	6.9
	27	16.0	16.0	17.0	14.2	18.6	10.9	17.0	17.0	18.1	14.7	19.3	11.5	15.0	15.0	15.8	13.6	17.7	10.5	13.9	13.9	14.5	13.0	16.6	10.0
	30	17.4	17.4	17.4	17.4	18.8	13.8	18.2	18.2	18.4	17.8	19.5	13.9	16.4	16.4	16.4	16.4	17.8	13.6	15.4	15.4	15.4	15.4	16.7	13.2
	33	18.5	18.5	18.5	18.5	19.0	16.7	19.1	19.1	19.1	19.1	19.8	16.7	17.6	17.6	17.6	17.6	18.1	16.6	16.7	16.7	16.7	16.7	17.0	16.3
3740	24	15.3	15.0	17.2	11.5	18.7	8.1	16.5	15.6	18.2	12.0	19.3	8.4	14.1	14.1	15.9	11.0	17.8	7.6	12.9	12.9	14.5	10.8	16.7	7.1
	27	16.6	16.6	17.4	15.0	18.8	11.2	17.5	17.5	18.3	15.4	19.6	11.3	15.6	15.6	16.2	14.5	17.9	11.0	14.4	14.4	14.8	13.9	16.8	10.5
	30	17.9	17.9	17.9	17.9	19.0	14.4	18.6	18.6	18.7	18.7	19.7	14.4	17.0	17.0	17.0	17.0	18.0	14.2	15.9	15.9	15.9	15.9	16.9	13.0
	33	18.9	18.9	18.9	18.9	19.3	17.5	19.5	19.5	19.5	19.5	20.0	17.4	18.1	18.1	18.1	18.1	18.4	17.5	17.2	17.2	17.2	17.2	17.3	17.2
4080	24	15.6	15.6	17.4	12.1	18.8	8.3	16.8	16.4	18.4	12.4	19.5	8.6	14.5	14.5	16.1	11.5	17.9	7.9	13.4	13.4	14.7	10.8	16.9	7.3
	27	17.1	17.1	17.6	15.8	18.9	11.6	18.0	18.0	18.5	16.0	19.7	11.8	16.1	16.1	16.5	15.3	18.1	11.4	14.9	14.9	15.1	14.7	17.0	11.0
	30	18.3	18.3	18.3	18.3	19.2	14.9	19.0	19.0	19.0	19.0	19.9	14.8	17.4	17.4	17.4	17.4	18.2	14.9	16.4	16.4	16.4	16.4	17.1	14.6
	33	19.2	19.2	19.2	19.2	19.5	18.2	19.8	19.8	19.8	19.8	20.2	17.9	18.5	18.5	18.5	18.5	18.6	18.2	17.6	17.6	17.6	17.6	17.6	17.6

**Notes:**

1. All capacities shown are gross and have not considered indoor fan heat. To obtain net cooling, subtract indoor fan heat.
2. TGC = Total Gross Capacity
3. SHC = Sensible Heat Capacity

**Table PD-1a – Gross Cooling Capacities (MBH) WSC060AD,T (IP)**

CFM Airflow	Enter. Dry Bulb Temp (F)	Ambient Temperature (F)																							
		85						95						105						115					
		Entering Wet Bulb Temperature (F)																							
		61		67		73		61		67		73		61		67		73		61		67		73	
		TGC	SHC	TGC	SHC	TGC	SHC	TGC	SHC	TGC	SHC	TGC	SHC	TGC	SHC	TGC	SHC	TGC	SHC	TGC	SHC	TGC	SHC		
1800	75	54.0	46.5	61.5	35.8	65.9	24.0	49.6	44.2	57.7	34.7	63.5	22.6	45.0	41.9	52.8	32.5	60.3	21.1	40.3	39.5	47.6	30.2	56.2	19.4
	80	55.3	55.3	61.7	44.9	66.5	33.3	51.8	51.8	57.9	43.1	64.0	31.9	48.0	48.0	53.1	40.9	60.6	30.2	44.0	44.0	47.9	38.5	56.4	28.4
	85	59.5	59.5	62.2	53.8	67.1	42.4	56.1	56.1	58.5	52.3	64.3	40.4	52.3	52.3	54.0	50.2	60.9	39.3	48.4	48.4	49.1	47.9	56.6	37.4
	90	62.9	62.9	63.3	62.7	67.6	49.1	60.1	60.1	60.1	60.1	64.8	48.8	56.6	56.6	56.6	56.6	61.2	47.9	52.8	52.8	52.8	52.8	57.0	46.4
2000	75	55.5	49.5	62.4	38.3	66.5	24.4	51.0	47.2	58.8	35.6	64.1	23.1	46.4	44.9	54.0	34.4	61.0	21.6	41.6	41.6	48.6	32.1	57.0	19.9
	80	57.7	57.7	62.6	47.1	67.2	34.4	54.1	54.1	59.0	45.7	64.6	33.2	50.1	50.1	54.4	43.5	61.3	31.6	46.0	46.0	49.1	41.2	57.2	29.8
	85	61.6	61.6	63.4	56.8	68.0	42.9	58.5	58.5	59.9	55.8	65.0	42.0	54.7	54.7	55.5	53.9	61.6	41.1	50.6	50.6	50.6	50.6	57.4	39.7
	90	64.8	64.8	64.8	64.8	68.3	50.9	62.1	62.1	62.1	62.1	65.6	51.1	58.9	58.9	58.9	58.9	62.2	50.6	55.1	55.1	55.1	55.1	58.0	49.4
2200	75	56.8	52.4	63.1	39.9	66.9	24.8	52.3	50.1	59.6	37.2	64.5	23.5	47.3	47.3	54.9	35.1	61.5	22.0	43.1	43.1	49.5	34.0	57.6	20.4
	80	59.7	59.7	63.4	49.2	67.7	35.1	56.1	56.1	59.9	48.1	64.9	35.4	52.1	52.1	55.4	46.1	61.9	32.9	47.8	47.8	50.2	43.8	57.9	31.1
	85	63.2	63.2	64.3	59.5	68.5	44.1	60.3	60.3	61.0	58.9	65.6	45.3	56.7	56.7	56.7	56.7	62.3	42.9	52.7	52.7	52.6	52.6	58.1	41.7
	90	66.2	66.2	66.1	66.1	69.3	53.4	63.7	63.7	63.6	63.6	66.3	53.1	60.6	60.6	60.6	60.6	63.0	53.0	57.0	57.0	57.0	57.0	58.9	52.2
2400	75	57.9	55.2	63.6	41.2	67.2	25.2	53.5	52.9	60.3	38.8	64.9	23.9	48.9	48.9	55.7	38.1	61.9	22.4	44.5	44.5	50.3	34.3	58.1	20.8
	80	61.2	61.2	64.1	51.1	68.1	35.7	57.8	57.8	60.7	50.3	65.9	34.3	53.8	53.8	56.3	48.6	62.3	33.8	49.4	49.4	51.2	46.3	58.4	32.4
	85	64.5	64.5	65.1	61.9	69.0	45.2	61.7	61.7	62.0	61.8	66.1	44.8	58.3	58.3	58.3	58.3	62.8	44.5	54.3	54.3	54.3	54.3	58.8	43.7
	90	67.2	67.2	67.2	67.2	69.8	54.9	64.9	64.9	64.9	64.9	66.9	55.0	61.9	61.9	61.9	61.9	63.7	55.2	58.5	58.5	58.5	58.5	59.7	54.8

**Notes:**

1. All capacities shown are gross and have not considered indoor fan heat. To obtain net cooling, subtract indoor fan heat.
2. TGC = Total Gross Capacity
3. SHC = Sensible Heat Capacity

# Performance Data

**Table PD-2 – Gross Cooling Capacities (kW) WSC072AD,T (SI)**

m <sup>3</sup> /h Airflow	Enter. Dry Bulb Temp (C)	Ambient Temperature (C)																							
		30						35						40						45					
		Entering Wet Bulb Temperature (C)																							
		16	19	22		16	19	22		16	19	22		16	19	22		16	19	22		16	19	22	
		TGC	SHC	TGC	SHC	TGC	SHC	TGC	SHC	TGC	SHC	TGC	SHC	TGC	SHC	TGC	SHC	TGC	SHC	TGC	SHC	TGC	SHC	TGC	SHC
3670	24	20.3	18.1	22.7	14.4	23.9	10.2	19.0	17.4	21.7	14.0	23.6	9.9	17.6	16.7	20.2	13.4	22.9	9.6	16.1	16.0	18.6	12.7	21.7	9.2
	27	21.2	21.2	22.8	17.9	24.2	13.6	20.1	20.1	21.8	17.6	23.7	13.6	19.0	19.0	20.4	17.0	22.9	13.3	17.7	17.7	18.8	16.3	21.7	12.9
	30	22.6	22.6	23.1	21.5	24.4	16.7	21.9	21.9	22.2	21.5	23.8	16.8	20.8	20.8	20.9	20.9	23.0	16.8	19.5	19.5	19.5	19.5	21.8	16.5
	33	23.7	23.7	23.7	23.7	24.6	19.9	23.2	23.2	23.2	23.2	24.1	20.2	22.4	22.4	22.4	22.4	23.2	20.4	21.3	21.3	21.3	21.3	22.1	20.3
4080	24	20.9	19.3	23.0	15.1	24.1	10.4	19.5	18.6	22.2	14.6	23.8	10.2	18.1	17.9	20.7	14.0	23.1	9.8	16.7	16.7	19.0	13.5	22.1	9.5
	27	22.1	22.1	23.1	18.8	24.3	13.8	21.0	21.0	22.3	18.7	23.9	13.9	19.8	19.8	20.9	18.2	23.2	13.9	18.6	18.6	19.3	17.5	22.1	13.5
	30	23.3	23.3	23.5	22.5	24.6	17.1	22.7	22.7	22.6	22.6	24.1	17.5	21.7	21.7	21.7	21.7	23.3	17.7	20.5	20.5	20.5	20.5	22.2	17.6
	33	24.2	24.2	24.2	24.2	24.8	20.5	23.8	23.8	23.8	23.8	24.4	21.0	23.1	23.1	23.1	23.1	23.6	21.5	22.2	22.2	22.2	22.2	22.5	21.5
4490	24	21.4	20.4	23.2	15.6	24.2	10.7	20.1	19.8	22.5	15.3	23.9	10.4	18.7	18.7	21.1	14.7	23.3	10.1	17.3	17.3	19.3	14.3	22.3	9.7
	27	22.6	22.6	23.4	19.5	24.5	14.2	21.8	21.8	22.6	19.7	24.2	14.4	20.6	20.6	21.3	19.3	23.4	14.3	19.3	19.3	19.8	18.6	22.4	14.2
	30	23.7	23.7	23.8	23.4	24.8	17.7	23.2	23.2	23.2	23.2	24.3	18.1	22.4	22.4	22.4	22.4	23.6	18.5	21.2	21.2	21.2	21.2	22.5	18.5
	33	24.5	24.5	24.5	24.5	25.1	21.2	24.2	24.2	24.2	24.2	24.6	21.8	23.6	23.6	23.6	23.6	23.9	22.4	22.8	22.8	22.8	22.8	23.0	22.7
4900	24	21.9	21.6	23.4	16.1	24.3	10.8	20.5	20.5	22.7	15.9	24.0	10.6	19.3	19.3	21.4	15.4	23.4	10.4	17.9	17.9	19.7	15.1	22.5	10.0
	27	23.1	23.1	23.6	20.2	24.6	14.4	22.4	22.4	22.9	20.6	24.2	14.6	21.3	21.3	21.8	20.4	23.6	14.8	20.0	20.0	20.2	19.7	22.5	14.7
	30	24.0	24.0	24.0	24.0	24.9	18.1	23.6	23.6	23.6	23.6	24.4	18.6	22.9	22.9	22.9	22.9	23.8	19.1	22.0	22.0	22.0	22.0	22.8	19.4
	33	24.8	24.8	24.8	24.8	25.2	21.7	24.5	24.5	24.5	24.5	24.8	22.4	24.0	24.0	24.0	24.0	24.2	23.2	23.3	23.3	23.3	23.3	23.3	23.3

- Notes:  
1. All capacities shown are gross and have not considered indoor fan heat. To obtain net cooling, subtract indoor fan heat.  
2. TGC = Total Gross Capacity  
3. SHC = Sensible Heat Capacity

**Table PD-2a – Gross Cooling Capacities (MBH) WSC072AD,T (IP)**

CFM Airflow	Enter. Dry Bulb Temp (F)	Ambient Temperature (F)																							
		85						95						105						115					
		Entering Wet Bulb Temperature (F)																							
		61	67	73		61	67	73		61	67	73		61	67	73		61	67	73		61	67	73	
		TGC	SHC	TGC	SHC	TGC	SHC	TGC	SHC	TGC	SHC	TGC	SHC	TGC	SHC	TGC	SHC	TGC	SHC	TGC	SHC	TGC	SHC	TGC	SHC
2160	75	70.1	61.0	78.5	46.7	82.3	30.5	65.0	58.4	75.5	45.1	81.3	29.5	59.6	55.8	70.0	43.2	79.0	28.3	53.9	53.1	63.6	40.5	75.2	26.9
	80	72.0	72.0	78.8	57.5	83.2	41.7	68.0	68.0	75.7	56.9	81.8	41.4	63.6	63.6	70.3	54.6	79.4	40.1	58.9	58.9	64.0	51.9	75.3	38.7
	85	76.7	76.7	79.5	68.6	84.1	51.1	73.5	73.5	76.4	68.7	82.4	51.6	69.3	69.3	71.4	66.6	79.6	51.3	64.6	64.6	65.5	64.0	75.4	50.3
	90	80.2	80.2	80.6	79.2	84.9	60.6	78.1	78.1	78.1	78.1	82.9	61.4	74.8	74.8	74.8	74.8	80.1	62.2	70.3	70.3	70.3	70.3	75.8	61.9
2400	75	72.0	64.9	79.4	48.9	82.8	31.0	66.8	62.4	76.7	47.2	81.8	30.0	61.4	59.8	71.5	45.0	79.7	28.8	55.7	55.7	65.0	43.0	76.2	27.5
	80	75.0	75.0	79.8	59.9	83.7	42.4	71.1	71.1	77.0	60.1	82.6	42.5	66.5	66.5	71.9	58.1	80.1	41.8	61.6	61.6	65.6	55.4	76.3	40.4
	85	78.9	78.9	80.6	71.7	84.6	52.2	76.5	76.5	77.9	72.6	83.4	53.4	72.4	72.4	73.3	71.4	80.5	53.5	67.6	67.6	67.6	67.6	76.5	53.2
	90	81.9	81.9	81.8	81.8	85.5	62.3	80.2	80.2	80.2	80.2	84.2	64.5	77.5	77.5	77.4	77.4	81.2	65.2	73.5	73.5	73.5	73.5	77.1	65.5
2640	75	73.5	68.6	79.9	49.2	83.2	31.4	68.6	66.3	77.6	49.1	82.2	30.5	62.9	62.9	72.7	47.9	80.2	29.3	57.9	57.9	66.2	45.3	76.8	27.9
	80	77.0	77.0	80.6	62.0	84.1	43.0	73.6	73.6	78.0	62.8	83.1	43.3	69.1	69.1	73.3	61.4	80.7	43.6	64.0	64.0	67.1	58.9	77.1	42.0
	85	80.4	80.4	81.5	74.3	85.1	53.3	78.4	78.4	79.2	76.2	84.0	54.9	75.2	75.2	75.1	75.1	81.2	55.4	70.3	70.3	70.3	70.3	77.3	55.6
	90	83.0	83.0	83.0	83.0	86.0	63.8	81.8	81.8	81.8	81.8	84.9	66.5	79.4	79.4	79.4	79.4	82.0	67.8	76.0	76.0	76.0	76.0	78.2	68.9
2880	75	75.0	72.4	80.5	50.4	83.5	31.9	70.2	70.2	78.2	51.7	82.5	31.0	65.0	65.0	73.7	50.2	80.6	29.8	59.8	59.8	67.2	47.7	77.4	28.4
	80	78.5	78.5	81.2	63.8	84.5	43.5	75.9	75.9	78.9	65.4	83.5	44.1	71.4	71.4	74.6	64.9	81.2	44.2	66.2	66.2	68.4	62.3	77.7	43.6
	85	81.5	81.5	82.2	76.7	85.4	54.3	79.9	79.9	80.3	79.3	84.4	56.2	77.1	77.1	77.1	77.1	81.8	57.2	72.5	72.5	72.5	72.5	78.1	57.9
	90	83.9	83.9	83.9	83.9	86.4	65.2	82.9	82.9	82.9	82.9	85.4	68.3	80.8	80.8	80.8	80.8	82.7	70.2	77.6	77.6	77.6	77.6	79.1	71.9

- Notes:  
1. All capacities shown are gross and have not considered indoor fan heat. To obtain net cooling, subtract indoor fan heat.  
2. TGC = Total Gross Capacity  
3. SHC = Sensible Heat Capacity



# Performance Data

**Table PD-3 – Gross Cooling Capacities (kW) WSC090AD,T (SI)**

m <sup>3</sup> /h Airflow	Enter. Dry Bulb Temp (C)	Ambient Temperature (C)																							
		30						35						40						45					
		Entering Wet Bulb Temperature (C)																							
		16	19	22	16	19	22	16	19	22	16	19	22	16	19	22	16	19	22	16	19	22	16	19	22
4590	24	25.5	22.7	28.1	18.0	29.5	12.6	23.7	21.8	26.9	17.4	29.0	12.3	21.9	21.0	25.1	16.6	28.1	11.9	20.5	16.8	20.7	12.4	20.8	9.3
	27	26.5	26.5	28.2	22.3	29.8	16.8	25.2	25.2	27.1	22.1	29.2	17.0	23.7	23.7	25.3	21.3	28.2	16.5	20.8	19.8	21.0	14.8	21.1	11.4
	30	28.1	28.1	28.6	26.6	30.1	20.7	27.2	27.2	27.5	26.8	29.4	21.0	25.9	25.9	25.9	25.9	28.3	21.0	21.2	21.2	21.4	17.4	21.5	13.4
	33	29.3	29.3	29.3	29.3	30.5	24.7	28.7	28.7	28.7	28.7	29.6	25.0	27.8	27.8	27.8	27.8	28.6	25.3	21.6	21.6	21.7	19.9	21.9	15.6
5100	24	26.1	24.1	28.4	18.7	29.7	12.9	24.4	23.3	27.4	18.2	29.2	12.6	22.6	22.5	25.6	17.5	28.4	12.2	20.4	16.9	20.7	12.5	20.8	9.3
	27	27.4	27.4	28.6	23.2	30.0	17.2	26.2	26.2	27.6	23.3	29.5	17.4	24.7	24.7	25.9	22.7	28.5	17.3	20.8	20.0	21.1	15.0	21.2	11.4
	30	28.8	28.8	29.0	27.9	30.4	21.3	28.1	28.1	28.0	28.0	29.8	21.9	27.0	27.0	27.0	27.0	28.7	22.0	21.2	21.2	21.4	17.7	21.6	13.6
	33	29.9	29.9	29.9	29.9	30.7	25.4	29.4	29.4	29.4	29.4	30.1	26.3	28.6	28.6	28.6	28.6	29.1	26.6	21.6	21.6	21.8	20.2	22.0	15.8
5610	24	26.7	25.6	28.7	19.0	29.8	13.3	25.0	24.8	27.7	19.0	29.4	12.9	23.2	23.2	26.0	18.3	28.6	12.6	20.6	17.3	20.8	12.6	20.9	9.3
	27	28.1	28.1	28.9	24.1	30.2	17.5	27.1	27.1	28.0	24.4	29.7	17.8	25.6	25.6	26.4	24.0	28.7	17.8	20.9	20.4	21.1	15.2	21.2	11.5
	30	29.3	29.3	29.4	28.9	30.6	21.8	28.7	28.7	28.7	28.7	30.0	22.6	27.7	27.7	27.7	27.7	29.0	22.9	21.4	21.4	21.5	18.0	21.6	13.7
	33	30.2	30.2	30.2	30.2	30.9	26.1	29.8	29.8	29.8	29.8	30.4	27.2	29.1	29.1	29.1	29.1	29.4	27.7	21.8	21.8	21.9	20.5	22.0	15.9
6120	24	27.2	26.8	28.9	19.6	29.9	13.4	25.6	25.6	28.0	20.3	29.5	13.3	23.9	23.9	26.3	19.7	28.8	12.9	22.3	22.3	24.3	19.0	27.6	12.5
	27	28.5	28.5	29.2	24.9	30.3	17.8	27.7	27.7	28.3	25.4	29.9	18.2	26.4	26.4	27.0	25.4	29.0	18.4	24.8	24.8	25.1	24.6	27.7	18.3
	30	29.6	29.6	29.6	29.6	30.7	22.3	29.1	29.1	29.1	29.1	30.2	23.2	28.3	28.3	28.3	28.3	29.3	23.7	27.1	27.1	27.1	27.1	28.0	24.0
	33	30.5	30.5	30.5	30.5	31.1	26.8	30.2	30.2	30.2	30.2	30.7	28.0	29.6	29.6	29.6	29.6	29.7	28.7	28.7	28.7	28.7	28.7	28.7	28.7

- Notes:  
 1. All capacities shown are gross and have not considered indoor fan heat. To obtain net cooling, subtract indoor fan heat.  
 2. TGC = Total Gross Capacity  
 3. SHC = Sensible Heat Capacity

**Table PD-3a – Gross Cooling Capacities (MBH) WSC090AD,T (IP)**

CFM Airflow	Enter. Dry Bulb Temp (F)	Ambient Temperature (F)																							
		85						95						105						115					
		Entering Wet Bulb Temperature (F)																							
		61	67	73	61	67	73	61	67	73	61	67	73	61	67	73	61	67	73	61	67	73	61	67	73
2700	75	87.8	76.5	97.1	58.3	101.4	37.7	81.1	73.3	93.3	56.2	99.9	36.5	74.3	70.1	86.7	54.3	97.1	35.0	70.3	57.6	71.2	40.6	71.5	28.7
	80	90.1	90.1	97.5	71.3	102.5	52.9	85.0	85.0	93.6	70.9	100.7	51.5	79.4	79.4	87.1	68.3	97.6	49.8	71.3	67.7	72.3	48.5	72.7	35.8
	85	95.4	95.4	98.3	84.9	103.6	63.1	91.7	91.7	94.5	85.4	101.8	64.2	86.4	86.4	88.5	83.4	97.9	63.8	72.6	72.6	73.4	56.8	73.9	42.3
	90	99.3	99.3	99.8	97.9	104.7	74.9	96.7	96.7	96.7	96.7	102.5	76.8	93.0	93.0	93.0	93.0	98.6	77.4	74.0	74.0	74.5	65.1	75.1	48.9
3000	75	89.9	81.2	97.8	59.7	102.0	38.3	83.4	78.2	94.6	58.6	100.6	37.1	76.5	75.0	88.3	57.2	97.8	35.6	70.5	58.6	71.4	41.0	71.7	29.3
	80	93.4	93.4	98.6	74.0	103.1	52.4	88.6	88.6	95.0	74.5	101.6	52.6	82.9	82.9	88.9	72.5	98.5	51.9	71.6	68.9	72.5	49.1	72.9	36.0
	85	97.8	97.8	99.7	88.5	104.3	64.5	94.7	94.7	96.3	90.1	102.7	66.1	89.9	89.9	91.1	89.4	99.1	66.5	73.0	73.0	73.7	57.7	74.2	42.7
	90	101.2	101.2	101.2	101.1	105.5	76.9	99.1	99.1	99.1	99.1	103.7	79.9	95.8	95.8	95.8	95.7	99.8	80.9	74.4	74.4	74.8	66.1	75.4	49.5
3300	75	91.9	85.9	98.6	61.8	102.4	39.0	85.5	83.0	95.6	62.2	101.0	37.7	78.3	78.3	89.7	58.7	98.5	36.3	70.8	59.6	71.6	41.4	71.9	29.1
	80	95.5	95.5	99.5	76.4	103.6	53.1	91.6	91.6	96.2	77.9	102.2	53.6	86.0	86.0	90.7	76.8	99.2	54.2	71.9	69.9	72.7	49.7	73.1	36.2
	85	99.4	99.4	100.7	91.5	104.9	65.7	96.9	96.9	97.8	94.3	103.3	67.8	93.1	93.1	93.0	93.0	100.0	69.1	73.3	73.3	73.9	58.5	74.3	43.0
	90	102.5	102.5	102.5	102.5	106.1	78.7	100.9	100.9	100.9	100.9	104.5	82.3	97.9	97.9	97.9	97.9	100.8	84.1	74.7	74.7	75.0	67.1	75.6	50.0
3600	75	93.4	89.8	99.2	63.4	102.8	39.5	86.9	86.9	96.5	64.9	101.5	38.4	80.8	80.8	91.1	61.4	99.0	36.9	71.0	60.5	71.7	41.8	72.0	29.1
	80	97.1	97.1	100.2	78.6	104.1	53.7	93.9	93.9	97.2	80.9	102.7	54.4	88.5	88.5	92.2	80.8	99.9	54.9	72.1	70.9	72.9	50.2	73.2	36.4
	85	100.7	100.7	101.5	94.2	105.3	66.9	98.6	98.6	99.0	97.9	103.9	69.4	95.0	95.0	95.0	95.0	100.9	71.6	73.5	73.5	74.0	59.3	74.5	43.3
	90	103.5	103.5	103.5	103.5	106.6	80.4	102.1	102.1	102.1	102.1	105.1	84.5	99.6	99.6	99.6	99.6	102.1	87.8	74.9	74.9	75.2	68.0	75.8	50.5

- Notes:  
 1. All capacities shown are gross and have not considered indoor fan heat. To obtain net cooling, subtract indoor fan heat.  
 2. TGC = Total Gross Capacity  
 3. SHC = Sensible Heat Capacity



# Performance Data

**Table PD-4 – Gross Cooling Capacities (kW) WSC120AD,T (SI)**

m³/h	Enter. Dry Bulb Temp (C)	Ambient Temperature (C)																							
		30						35						40						45					
		Entering Wet Bulb Temperature (C)																							
Airflow (C)	16	19	22	16	19	22	16	19	22	16	19	22	16	19	22	16	19	22	16	19	22	16	19	22	
6120	24	31.0	27.0	35.1	21.7	37.3	15.9	29.0	26.0	33.3	20.8	36.4	15.3	26.8	24.9	31.0	19.8	35.0	14.5	24.2	24.2	28.4	19.9	33.1	13.7
	27	32.3	31.9	35.2	27.2	37.6	21.2	30.4	30.4	33.4	26.3	36.6	20.7	28.6	28.6	31.1	25.3	35.1	20.0	26.8	26.8	28.7	24.2	33.1	19.1
	30	34.6	34.6	35.6	32.6	38.0	26.0	33.1	33.1	33.9	32.0	36.8	25.7	31.4	31.4	31.3	31.3	35.2	25.3	29.5	29.5	29.8	29.2	33.2	24.6
	33	36.6	36.6	36.6	36.5	38.2	30.6	35.4	35.4	35.4	35.4	37.1	30.8	33.9	33.9	33.9	33.9	35.5	30.6	32.2	32.2	32.2	32.2	33.6	30.0
6800	24	31.9	28.7	35.6	22.7	37.6	16.2	29.8	27.6	33.9	21.8	36.7	15.9	27.1	27.1	31.7	20.8	35.4	15.0	25.2	25.2	29.1	19.7	33.6	14.1
	27	33.4	33.4	35.8	28.5	37.9	21.7	31.7	31.7	34.1	27.9	36.9	22.8	29.9	29.9	31.9	26.9	35.5	20.9	28.0	28.0	29.5	25.8	33.6	20.1
	30	35.8	35.8	36.3	34.3	38.2	26.6	34.4	34.4	34.4	34.4	37.2	26.7	32.7	32.7	33.0	32.2	35.7	26.6	30.8	30.8	30.9	30.8	33.8	26.0
	33	37.5	37.5	37.5	37.5	38.6	30.7	36.4	36.4	36.4	36.4	37.6	32.1	35.1	35.1	35.0	35.0	36.1	32.2	33.5	33.5	33.5	33.5	34.3	31.8
7480	24	32.7	30.3	36.0	23.5	37.9	16.8	30.0	30.0	34.4	22.8	36.9	16.2	28.1	28.1	32.2	21.8	35.6	15.7	26.3	25.9	29.7	20.7	33.9	14.5
	27	34.5	34.5	36.3	29.7	38.2	22.2	32.9	32.9	34.7	29.3	37.1	22.1	31.0	31.0	32.5	28.4	35.8	21.6	29.1	29.1	30.2	27.4	34.1	21.0
	30	36.6	36.6	36.6	36.6	38.5	27.5	35.4	35.4	35.3	35.3	37.5	27.6	33.8	33.8	33.9	33.6	36.1	27.6	32.0	32.0	32.0	32.0	34.3	27.3
	33	38.1	38.1	38.1	38.1	38.9	32.5	37.2	37.2	37.2	37.2	37.9	33.2	35.9	35.9	35.9	35.9	36.6	33.6	34.4	34.4	34.4	34.4	34.4	34.4
8160	24	32.8	32.8	36.3	24.2	37.9	17.1	30.9	30.9	34.8	23.7	37.1	16.8	29.0	29.0	32.7	22.7	35.9	16.1	26.9	26.9	30.2	21.6	34.2	14.9
	27	35.4	35.4	36.7	30.8	38.4	22.5	33.9	33.9	35.1	30.6	37.4	22.6	32.0	32.0	33.1	29.9	36.1	22.2	30.0	30.0	30.8	28.9	34.4	21.8
	30	37.2	37.2	37.2	37.2	38.9	28.1	36.1	36.1	36.1	35.7	37.7	28.4	34.7	34.7	34.6	34.6	36.4	28.6	32.9	32.9	32.9	32.9	34.7	28.4
	33	38.6	38.6	38.5	38.5	39.4	33.8	37.7	37.7	37.7	37.7	38.2	34.2	36.6	36.6	36.6	36.6	37.0	34.7	35.1	35.1	35.1	35.1	35.1	35.1

- Notes:  
 1. All capacities shown are gross and have not considered indoor fan heat. To obtain net cooling, subtract indoor fan heat.  
 2. TGC = Total Gross Capacity  
 3. SHC = Sensible Heat Capacity

**Table PD-4a – Gross Cooling Capacities (MBH) WSC120AD,T (IP)**

CFM	Enter. Dry Bulb Temp (F)	Ambient Temperature (F)																							
		85						95						105						115					
		Entering Wet Bulb Temperature (F)																							
Airflow (F)	61	67	73	61	67	73	61	67	73	61	67	73	61	67	73	61	67	73	61	67	73	61	67	73	
3600	75	107.1	91.1	121.9	71.0	128.7	47.6	99.2	87.2	115.7	67.7	125.5	45.7	91.0	83.1	107.0	67.2	120.9	43.4	80.7	80.7	97.5	63.2	114.4	40.5
	80	109.1	109.1	122.1	88.0	130.0	66.8	103.3	102.4	115.9	85.0	126.5	63.3	96.0	96.0	107.5	81.2	121.4	60.7	89.0	89.0	98.1	77.1	114.6	57.7
	85	117.2	117.2	123.0	104.8	131.4	80.1	111.2	111.2	116.8	102.7	127.3	78.9	104.6	104.6	108.8	99.1	121.7	77.5	97.5	97.5	100.1	95.2	114.9	74.8
	90	123.7	123.7	123.6	123.6	132.5	94.8	118.9	118.9	118.8	118.8	128.1	94.3	112.9	112.9	113.2	112.8	122.6	93.8	106.1	106.1	106.1	106.1	115.4	91.8
4000	75	110.0	96.6	123.5	73.7	129.3	48.4	101.9	92.6	117.7	70.7	126.3	46.5	93.6	88.6	109.4	67.0	121.9	44.2	84.1	84.1	99.8	62.9	115.8	41.4
	80	114.1	113.0	123.9	91.8	130.8	66.7	107.2	107.2	118.0	89.7	127.5	65.8	100.2	100.2	109.9	86.1	122.7	63.2	92.9	92.9	100.5	82.1	116.1	60.2
	85	121.2	121.2	125.0	109.8	132.3	82.0	115.8	115.8	119.2	108.7	128.3	82.0	109.2	109.2	111.8	105.8	123.2	80.7	102.0	102.0	101.9	101.9	116.6	78.9
	90	126.8	126.8	126.8	126.8	133.8	97.6	122.6	122.6	122.7	122.1	129.4	97.7	117.2	117.2	117.1	117.1	124.2	98.1	110.7	110.7	110.6	110.6	117.4	97.0
4400	75	112.5	101.9	124.4	77.0	129.8	49.0	104.5	98.0	119.3	73.6	127.0	47.1	94.7	94.7	111.3	70.0	122.7	45.1	87.9	86.2	101.8	65.9	116.8	42.1
	80	117.5	117.5	125.3	95.1	131.4	67.5	111.1	111.1	119.7	93.9	128.3	70.3	104.0	104.0	112.0	90.7	123.6	65.8	96.5	96.5	102.7	86.8	117.3	62.6
	85	124.1	124.1	126.6	114.1	133.0	83.5	119.3	119.3	121.3	114.1	129.9	84.1	113.0	113.0	113.0	113.0	124.3	83.3	105.8	105.8	106.7	104.3	117.8	82.2
	90	129.1	129.1	129.0	129.0	134.5	99.7	125.4	125.4	125.3	125.3	131.4	100.4	120.3	120.3	120.3	120.3	125.5	101.8	114.2	114.2	114.2	114.2	119.0	101.6
4800	75	114.7	106.9	125.4	79.1	130.3	49.6	105.1	105.1	120.5	76.3	127.4	48.1	97.7	97.7	112.9	72.8	123.3	46.0	90.3	89.8	103.4	68.7	117.6	43.0
	80	120.3	120.3	126.4	98.0	131.9	68.3	114.4	114.4	121.2	97.7	129.0	68.0	107.3	107.3	113.8	95.2	124.2	66.4	99.6	99.6	104.6	91.3	118.3	64.8
	85	126.3	126.3	127.8	117.8	133.5	84.7	121.9	121.9	121.9	121.9	130.5	86.0	116.1	116.1	116.1	116.1	125.4	85.7	109.1	109.1	109.4	108.7	118.9	85.2
	90	131.1	131.1	130.6	130.6	135.1	101.6	127.4	127.4	127.3	127.3	131.3	103.4	122.7	122.7	122.7	122.7	126.6	105.0	116.9	116.9	116.9	116.9	120.3	105.6

- Notes:  
 1. All capacities shown are gross and have not considered indoor fan heat. To obtain net cooling, subtract indoor fan heat.  
 2. TGC = Total Gross Capacity  
 3. SHC = Sensible Heat Capacity



# Performance Data

**Table PD-5 - Net Heating Capacities (kW) WSC060AD,T at 3,400 m<sup>3</sup>/h (SI)**

Outdoor Temp (C)	Integrated Heating Capacity (kW) At Indicated Indoor Dry BulbTemp (C)				Total Power (kW) At Indicated Indoor Dry BulbTemp (C)			
	15	21	24	27	15	21	24	27
-24	4.1	4.1	4.1	4.0	3.2	3.7	3.9	4.2
-21	4.9	4.9	4.8	4.8	3.3	3.8	4.0	4.3
-18	5.8	5.7	5.6	5.5	3.4	3.8	4.1	4.3
-15	6.7	6.5	6.4	6.3	3.5	3.9	4.2	4.4
-12	7.6	7.4	7.3	7.2	3.6	4.0	4.3	4.5
-9	8.6	8.3	8.2	8.1	3.7	4.1	4.3	4.6
-6	9.6	9.3	9.1	9.0	3.8	4.2	4.4	4.7
-3	10.6	10.3	10.1	10.0	3.9	4.3	4.5	4.8
0	11.7	11.4	11.2	11.0	4.0	4.4	4.6	4.9
3	12.8	12.4	12.2	12.0	4.1	4.5	4.7	5.0
6	13.9	13.5	13.3	13.1	4.2	4.6	4.8	5.1
9	16.7	16.2	15.9	15.7	4.3	4.7	5.0	5.2
12	18.0	17.4	17.1	16.9	4.4	4.8	5.1	5.4
15	19.3	18.7	18.4	18.1	4.5	5.0	5.2	5.5
18	20.7	20.1	19.7	19.4	4.7	5.2	5.4	5.7
21	22.1	21.4	21.1	20.7	4.8	5.3	5.6	5.9
24	23.6	22.8	22.4	22.1	5.0	5.5	5.8	6.1

Notes:

1. Net heating capacity and power include indoor fan heat at ARI ESP. To obtain net heating at other conditions, subtract fan heat at this condition and add fan heat at new condition.
2. Integrated heating capacities and power include the effects of defrost in the frost region. All heating capacities and power are at 70 % outdoor relative humidity and demand defrost cycle.

**Table PD-5a - Net Heating Capacities (MBH) WSC060AD,T at 2,000 CFM (IP)**

Outdoor Temp (F)	Integrated Heating Capacity (MBh) At Indicated Indoor Dry BulbTemp (F)				Total Power (kW) At Indicated Indoor Dry BulbTemp (F)			
	60	70	75	80	60	70	75	80
-8	15.8	15.6	15.4	15.2	3.3	3.7	4.0	4.2
-3	18.3	18.0	17.8	17.6	3.4	3.8	4.0	4.3
2	21.0	20.6	20.3	20.0	3.5	3.9	4.1	4.4
7	23.9	23.3	23.0	22.6	3.6	4.0	4.2	4.4
12	26.8	26.1	25.7	25.4	3.7	4.1	4.3	4.5
17	29.9	29.1	28.7	28.2	3.8	4.1	4.4	4.6
22	33.1	32.2	31.7	31.2	3.8	4.2	4.4	4.7
27	36.5	35.4	34.9	34.4	3.9	4.3	4.5	4.8
32	39.9	38.8	38.2	37.6	4.0	4.4	4.6	4.9
37	43.4	42.0	41.4	40.8	4.1	4.5	4.7	5.0
42	46.8	45.4	44.7	44.1	4.2	4.6	4.8	5.1
47	56.0	54.2	53.4	52.7	4.3	4.7	4.9	5.2
52	60.0	58.1	57.3	56.5	4.4	4.8	5.0	5.3
57	64.1	62.1	61.1	60.3	4.5	4.9	5.2	5.4
62	68.4	66.3	65.4	64.4	4.6	5.1	5.3	5.6
67	72.7	70.6	69.6	68.5	4.8	5.3	5.5	5.8
72	77.3	75.0	73.9	72.7	5.0	5.4	5.7	6.0

Notes:

1. Net heating capacity and power include indoor fan heat at ARI ESP. To obtain net heating at other conditions, subtract fan heat at this condition and add fan heat at new condition.
2. Integrated heating capacities and power include the effects of defrost in the frost region. All heating capacities and power are at 70 % outdoor relative humidity and demand defrost cycle.

# Performance Data

**Table PD-6 – Three Phase Net Heating Capacities (kW) WSC072AD,T at 4,080 m<sup>3</sup>/h (SI)**

Outdoor Temp (C)	Integrated Heating Capacity (kW) At Indicated Indoor Dry Bulb Temp (C)				Total Power (kW) At Indicated Indoor Dry Bulb Temp (C)			
	15	21	24	27	15	21	24	27
-24	6.3	6.2	6.2	6.2	4.5	4.9	5.1	5.3
-21	7.3	7.2	7.1	7.1	4.6	5.0	5.2	5.4
-18	8.3	8.1	8.1	8.0	4.7	5.0	5.2	5.5
-15	9.3	9.1	9.0	8.9	4.7	5.1	5.3	5.6
-12	10.4	10.2	10.1	9.9	4.8	5.2	5.4	5.6
-9	11.5	11.2	11.1	11.0	4.9	5.3	5.5	5.7
-6	12.6	12.3	12.2	12.1	5.0	5.4	5.6	5.8
-3	13.8	13.5	13.3	13.1	5.0	5.5	5.7	5.9
0	15.0	14.7	14.5	14.3	5.1	5.6	5.8	6.0
3	16.3	15.9	15.7	15.5	5.2	5.7	5.9	6.2
6	17.6	17.2	16.9	16.7	5.3	5.8	6.0	6.3
9	21.0	20.5	20.3	20.0	5.4	5.9	6.1	6.4
12	22.6	22.0	21.8	21.5	5.5	6.0	6.2	6.5
15	24.2	23.6	23.3	23.0	5.6	6.1	6.4	6.7
18	25.8	25.2	24.9	24.6	5.8	6.2	6.5	6.8
21	27.5	26.8	26.5	26.1	5.9	6.4	6.7	7.0
24	29.2	28.2	27.9	27.5	6.0	6.5	6.8	7.1

Notes:

1. Net heating capacity and power include indoor fan heat at ARI ESP. To obtain net heating at other conditions, subtract fan heat at this condition and add fan heat at new condition.
2. Integrated heating capacities and power include the effects of defrost in the frost region. All heating capacities and power are at 70 % outdoor relative humidity and demand defrost cycle.

**Table PD-6a – Three Phase Net Heating Capacities (MBH) WSC072AD,T at 2,400 CFM (IP)**

Outdoor Temp (F)	Integrated Heating Capacity (MBh) At Indicated Indoor Dry Bulb Temp (F)				Total Power (kW) At Indicated Indoor Dry Bulb Temp (F)			
	60	70	75	80	60	70	75	80
-8	23.4	23.2	23.0	22.9	4.6	4.9	5.1	5.3
-3	26.6	26.2	26.0	25.8	4.7	5.0	5.2	5.4
2	29.8	29.2	29.0	28.7	4.7	5.1	5.3	5.5
7	33.1	32.5	32.1	31.8	4.8	5.2	5.4	5.6
12	36.5	35.8	35.4	35.0	4.9	5.2	5.4	5.6
17	40.1	39.2	38.8	38.4	4.9	5.3	5.5	5.7
22	43.5	42.6	42.1	41.8	5.0	5.4	5.6	5.8
27	47.2	46.2	45.7	45.2	5.1	5.5	5.7	5.9
32	51.1	50.0	49.5	48.9	5.2	5.6	5.8	6.0
37	55.1	53.9	53.3	52.7	5.3	5.7	5.9	6.1
42	59.1	57.9	57.2	56.6	5.3	5.8	6.0	6.2
47	70.4	68.9	68.1	67.3	5.4	5.9	6.1	6.3
52	75.3	73.6	72.8	71.9	5.5	6.0	6.2	6.5
57	80.3	78.5	77.6	76.7	5.6	6.1	6.3	6.6
62	85.4	83.5	82.6	81.6	5.7	6.2	6.4	6.7
67	90.6	88.6	87.6	86.5	5.9	6.3	6.6	6.9
72	95.9	93.8	92.7	91.5	6.0	6.5	6.7	7.0

Notes:

1. Net heating capacity and power include indoor fan heat at ARI ESP. To obtain net heating at other conditions, subtract fan heat at this condition and add fan heat at new condition.
2. Integrated heating capacities and power include the effects of defrost in the frost region. All heating capacities and power are at 70 % outdoor relative humidity and demand defrost cycle.



# Performance Data

**Table PD-7 – Three Phase Net Heating Capacities (kW) WSC090AD,T at 5,100 m<sup>3</sup>/h (SI)**

Outdoor Temp (C)	Integrated Heating Capacity (kW) At Indicated Indoor Dry BulbTemp (C)				Total Power (kW) At Indicated Indoor Dry BulbTemp (C)			
	15	21	24	27	15	21	24	27
-24	4.0	7.3	8.2	8.7	4.8	5.8	6.2	6.7
-21	6.5	8.6	9.2	9.6	5.1	5.9	6.3	6.7
-18	8.4	9.8	10.3	10.5	5.2	6.0	6.4	6.8
-15	9.9	11.0	11.3	11.5	5.4	6.1	6.5	6.9
-12	11.5	12.2	12.5	12.6	5.5	6.2	6.6	6.9
-9	13.0	13.5	13.7	13.7	5.6	6.3	6.6	7.0
-6	14.6	14.9	14.9	14.9	5.8	6.4	6.7	7.1
-3	16.2	16.3	16.2	16.2	5.9	6.5	6.8	7.2
0	17.8	17.7	17.6	17.5	6.0	6.6	6.9	7.3
3	19.4	19.2	19.0	18.9	6.1	6.7	7.0	7.4
6	21.0	20.7	20.5	20.3	6.2	6.8	7.1	7.5
9	25.1	24.7	24.4	24.2	6.3	6.9	7.2	7.6
12	27.0	26.5	26.2	25.9	6.4	7.0	7.3	7.7
15	29.0	28.3	28.0	27.7	6.5	7.1	7.5	7.9
18	31.0	30.2	29.8	29.5	6.6	7.2	7.6	8.0
21	32.7	31.7	31.3	30.9	6.7	7.4	7.8	8.2
24	34.7	33.7	33.3	32.8	6.9	7.6	7.9	8.4

Notes:

1. Net heating capacity and power include indoor fan heat at ARI ESP. To obtain net heating at other conditions, subtract fan heat at this condition and add fan heat at new condition.
2. Integrated heating capacities and power include the effects of defrost in the frost region. All heating capacities and power are at 70 % outdoor relative humidity and demand defrost cycle.

**Table PD-7a – Three Phase Net Heating Capacities (MBH) WSC090AD,T at 3,000 CFM (IP)**

Outdoor Temp (F)	Integrated Heating Capacity (MBh) At Indicated Indoor Dry BulbTemp (F)				Total Power (kW) At Indicated Indoor Dry BulbTemp (F)			
	60	70	75	80	60	70	75	80
-8	20.2	27.7	30.0	31.5	5.0	5.9	6.3	6.7
-3	26.3	31.7	33.4	34.3	5.2	6.0	6.3	6.7
2	31.6	35.4	36.6	37.3	5.4	6.1	6.4	6.8
7	36.2	39.2	40.0	40.5	5.5	6.2	6.5	6.8
12	40.9	43.1	43.7	44.0	5.6	6.2	6.6	6.9
17	45.8	47.2	47.5	47.6	5.7	6.3	6.6	7.0
22	50.7	51.5	51.6	51.5	5.8	6.4	6.7	7.1
27	55.7	55.9	55.8	55.5	5.9	6.5	6.8	7.1
32	60.7	60.5	60.2	59.8	6.0	6.6	6.9	7.2
37	65.7	65.1	64.6	64.1	6.1	6.7	7.0	7.3
42	70.7	69.7	69.2	68.5	6.2	6.8	7.1	7.4
47	84.2	82.8	82.1	81.3	6.3	6.9	7.2	7.5
52	90.2	88.4	87.5	86.7	6.4	7.0	7.3	7.7
57	96.2	94.2	93.2	92.3	6.5	7.1	7.4	7.8
62	102.4	100.0	99.0	97.9	6.6	7.2	7.5	7.9
67	108.6	104.9	103.7	102.5	6.7	7.3	7.7	8.0
72	114.0	111.0	109.6	108.3	6.8	7.5	7.8	8.2

Notes:

1. Net heating capacity and power include indoor fan heat at ARI ESP. To obtain net heating at other conditions, subtract fan heat at this condition and add fan heat at new condition.
2. Integrated heating capacities and power include the effects of defrost in the frost region. All heating capacities and power are at 70 % outdoor relative humidity and demand defrost cycle.

# Performance Data

**Table PD-8 – Three Phase Net Heating Capacities (kW) WSC120AD,T at 6,800 m<sup>3</sup>/h (SI)**

Outdoor Temp (C)	Integrated Heating Capacity (kW) At Indicated Indoor Dry Bulb Temp (C)				Total Power (kW) At Indicated Indoor Dry Bulb Temp (C)			
	15	21	24	27	15	21	24	27
- 24	11.8	11.6	11.6	11.6	7.2	8.0	8.5	9.0
-21	12.8	12.7	12.7	12.8	7.3	8.1	8.6	9.1
-18	14.0	13.9	13.9	13.9	7.4	8.2	8.7	9.2
-15	15.3	15.2	15.2	15.2	7.5	8.3	8.8	9.3
-12	16.8	16.7	16.6	16.6	7.6	8.4	8.9	9.4
-9	18.3	18.2	18.2	18.1	7.7	8.6	9.0	9.5
-6	20.1	19.9	19.8	19.7	7.9	8.7	9.2	9.7
-3	21.9	21.7	21.6	21.4	8.0	8.9	9.3	9.8
0	23.9	23.6	23.4	23.3	8.2	9.0	9.5	10.0
3	25.8	25.5	25.3	25.1	8.3	9.2	9.7	10.2
6	27.9	27.4	27.2	27.0	8.5	9.3	9.8	10.3
9	33.3	32.7	32.4	32.1	8.7	9.5	10.0	10.5
12	35.8	35.1	34.8	34.4	8.9	9.7	10.2	10.8
15	38.4	37.5	37.1	36.7	9.1	10.0	10.5	11.0
18	40.9	40.0	39.6	39.1	9.3	10.2	10.7	11.3
21	43.7	42.7	42.1	41.6	9.5	10.5	11.0	11.6
24	46.6	45.5	44.9	44.3	9.9	10.8	11.4	11.9

Notes:

1. Net heating capacity and power include indoor fan heat at ARI ESP. To obtain net heating at other conditions, subtract fan heat at this condition and add fan heat at new condition.
2. Integrated heating capacities and power include the effects of defrost in the frost region. All heating capacities and power are at 70 % outdoor relative humidity and demand defrost cycle.

**Table PD-8a – Three Phase Net Heating Capacities (MBH) WSC120AD,T at 4,000 CFM (IP)**

Outdoor Temp (F)	Integrated Heating Capacity (MBh) At Indicated Indoor Dry Bulb Temp (F)				Total Power (kW) At Indicated Indoor Dry Bulb Temp (F)			
	60	70	75	80	60	70	75	80
- 8	42.1	41.9	41.8	41.9	7.3	8.1	8.5	9.0
- 3	45.7	45.5	45.5	45.6	7.4	8.2	8.6	9.1
2	49.7	49.5	49.5	49.5	7.5	8.3	8.7	9.2
7	54.0	53.8	53.7	53.7	7.6	8.4	8.8	9.3
12	58.7	58.4	58.3	58.2	7.7	8.5	8.9	9.4
17	63.8	63.4	63.2	63.0	7.8	8.6	9.1	9.5
22	69.3	68.7	68.5	68.2	8.0	8.7	9.2	9.6
27	75.1	74.4	74.0	73.7	8.1	8.9	9.3	9.8
32	81.3	80.4	79.9	79.5	8.2	9.0	9.5	9.9
37	87.5	86.4	85.8	85.2	8.4	9.2	9.6	10.1
42	93.9	92.5	91.8	91.1	8.5	9.3	9.8	10.3
47	111.7	109.9	109.0	108.1	8.7	9.5	10.0	10.4
52	119.4	117.3	116.3	115.2	8.9	9.7	10.2	10.6
57	127.4	124.9	123.8	122.6	9.1	9.9	10.4	10.8
62	135.5	132.7	131.4	130.0	9.3	10.1	10.6	11.1
67	143.6	140.5	139.0	137.4	9.5	10.3	10.8	11.3
72	152.8	149.4	147.7	146.0	9.8	10.6	11.1	11.6

Notes:

1. Net heating capacity and power include indoor fan heat at ARI ESP. To obtain net heating at other conditions, subtract fan heat at this condition and add fan heat at new condition.
2. Integrated heating capacities and power include the effects of defrost in the frost region. All heating capacities and power are at 70 % outdoor relative humidity and demand defrost cycle.



# Performance Data

**Table PD-9 – Belt Drive Evaporator Fan Performance WSC060AD,T Downflow Configuration (SI)**

External Static Pressure (Pascals)																					
		25		50		75		100		125		150		175		200		225		250	
m³/h	RPM	kW	RPM	kW	RPM	kW	RPM	kW	RPM	kW	RPM	kW	RPM	kW	RPM	kW	RPM	kW	RPM	kW	
<b>1.12 Nom kW Standard Motor &amp; Low Static Drive</b>											<b>1.12 Nom kW Standard Motor &amp; Drive</b>										
2720	-	-	690	0.26	746	0.30	795	0.34	843	0.38	889	0.42	933	0.47	975	0.53	1014	0.58	1050	0.63	
3060	693	0.31	746	0.34	802	0.39	848	0.44	892	0.48	935	0.52	976	0.57	1016	0.62	1056	0.68	1093	0.74	
3400	758	0.41	806	0.45	856	0.50	904	0.55	945	0.60	985	0.65	1023	0.70	1061	0.75	1098	0.80	1135	0.86	
3740	824	0.54	869	0.58	913	0.63	959	0.68	1001	0.74	1038	0.80	1074	0.85	1109	0.90	1143	0.96	1177	1.01	
4080	890	0.69	933	0.74	972	0.78	1014	0.84	1056	0.90	1094	0.97	1128	1.03	1160	1.09	1193	1.15	1225	1.20	

External Static Pressure (Pascals)											
		275		300		325		350		375	
m³/h	RPM	kW	RPM	kW	RPM	kW	RPM	kW	RPM	kW	
<b>1.12 Nom kW Standard Motor &amp; Drive</b>											
2720	1085	0.68	1118	0.72	1151	0.78	1183	0.83	1214	0.88	
3060	1128	0.80	1160	0.86	1192	0.91	1223	0.97	1252	1.02	
3400	1170	0.93	1203	1.00	1235	1.06	1265	1.12	1295	1.19	
3740	1212	1.07	1244	1.14	1276	1.21	1308	1.29	-	-	
4080	1256	1.26	1287	1.32	-	-	-	-	-	-	

← **1.12 Nom kW Standard Motor & Hi Static Drive**

Notes:  
Data Includes Pressure Drop Due To Wet Coils And Filters.  
1.12 kW - Fan Motor Heat (kW) = 1.144 x Fan kW + 0.132

Factory Supplied Motors, In Commercial Equipment, Are Definite Purpose Motors, Specifically Designed And Tested To Operate Reliably And Continuously At All Cataloged Conditions. Using The Full Horsepower Range Of Our Fan Motors As Shown In Our Tabular Data Will Not Result In Nuisance Tripping Or Premature Motor Failure. Our Product's Warranty Will Not Be Affected.

**Table PD-9a – Belt Drive Evaporator Fan Performance WSC060AD,T Downflow Configuration (IP)**

External Static Pressure (Inches of Water)																					
		0.10		0.20		0.30		0.40		0.50		0.60		0.70		0.80		0.90		1.00	
CFM	RPM	BHP	RPM	BHP	RPM	BHP	RPM	BHP	RPM	BHP	RPM	BHP	RPM	BHP	RPM	BHP	RPM	BHP	RPM	BHP	
<b>1- 1/2 HP Standard Motor &amp; Low Static Drive</b>											<b>1- 1/2 HP Standard Motor &amp; Drive</b>										
1600	-	-	690	0.35	746	0.40	795	0.46	843	0.51	889	0.57	933	0.64	975	0.71	1014	0.78	1050	0.84	
1800	693	0.41	746	0.46	802	0.52	848	0.59	892	0.65	935	0.70	976	0.76	1016	0.84	1056	0.92	1093	1.00	
2000	758	0.56	806	0.60	856	0.67	904	0.74	945	0.81	985	0.87	1023	0.94	1061	1.00	1098	1.07	1135	1.16	
2200	824	0.73	869	0.78	913	0.84	959	0.92	1001	1.00	1038	1.07	1074	1.15	1109	1.21	1143	1.28	1177	1.35	
2400	890	0.93	933	0.99	972	1.05	1014	1.12	1056	1.21	1094	1.30	1128	1.38	1160	1.46	1193	1.54	1225	1.61	
<b>1-1/2 HP Standard Motor &amp; Static Drive</b>																					

External Static Pressure (Inches of Water)											
		1.10		1.20		1.30		1.40		1.50	
CFM	RPM	BHP	RPM	BHP	RPM	BHP	RPM	BHP	RPM	BHP	
<b>1- 1/2 HP Standard Motor &amp; Drive</b>											
1600	1085	0.91	1118	0.97	1151	1.04	1183	1.11	1214	1.18	
1800	1128	1.08	1160	1.15	1192	1.22	1223	1.29	1252	1.37	
2000	1170	1.25	1203	1.34	1235	1.43	1265	1.51	1295	1.59	
2200	1212	1.44	1244	1.53	1276	1.63	1308	1.73	-	-	
2400	1256	1.69	1287	1.77	-	-	-	-	-	-	

← **1- 1/2 HP Standard Motor & Hi Static Drive**

Notes:  
Data Includes Pressure Drop Due To Wet Coils And Filters.  
1 1/2 HP - Fan Motor Heat (MBH) = 2.915 x Fan BHP + 0.451

Factory Supplied Motors, In Commercial Equipment, Are Definite Purpose Motors, Specifically Designed And Tested To Operate Reliably And Continuously At All Cataloged Conditions. Using The Full Horsepower Range Of Our Fan Motors As Shown In Our Tabular Data Will Not Result In Nuisance Tripping Or Premature Motor Failure. Our Product's Warranty Will Not Be Affected.



# Performance Data

**Table PD-10 – Belt Drive Evaporator Fan Performance WSC060AD,T Horizontal Configuration (SI)**

m³/h	External Static Pressure (Pascals)																			
	25		50		75		100		125		150		175		200		225		250	
	RPM	kW	RPM	kW	RPM	kW	RPM	kW	RPM	kW	RPM	kW	RPM	kW	RPM	kW	RPM	kW	RPM	kW
	<b>1.12 Nom kW Standard Motor &amp; Low Static Drive</b>										<b>1.12 Nom kW Standard Motor &amp; Drive</b>									
2720	692	0.25	761	0.30	823	0.36	884	0.41	941	0.47	990	0.52	1034	0.58	1077	0.64	1119	0.70	1158	0.75
3060	761	0.35	825	0.40	882	0.46	937	0.52	992	0.58	1043	0.65	1088	0.71	1130	0.77	1169	0.83	1207	0.90
3400	831	0.46	891	0.52	945	0.58	995	0.65	1045	0.72	1094	0.79	1141	0.86	1185	0.93	1224	1.00	1260	1.07
3740	901	0.60	958	0.67	1009	0.73	1057	0.80	1101	0.88	1146	0.95	1192	1.03	1235	1.11	1277	1.18	1314	1.26
4080	972.8	0.76	1026	0.84	1075	0.91	1120	0.98	1163	1.06	1204	1.14	1245	1.23	-	-	-	-	-	-

**1.12 Nom kW Standard Motor & Hi Static Drive**

m³/h	External Static Pressure (Pascals)									
	275		300		325		350		375	
	RPM	kW	RPM	kW	RPM	kW	RPM	kW	RPM	kW
	<b>1.12 Nom kW Standard Motor &amp; Drive</b>				<b>1.12 Nom kW Standard Motor &amp; Hi Static Drive</b>					
2720	1196	0.82	1231	0.88	1265	0.94	1298	1.00	1330	1.07
3060	1244	0.96	1280	1.03	1314	1.10	1346	1.16	1380	1.24
3400	1295	1.14	1330	1.21	1363	1.28	-	-	-	-
3740	-	-	-	-	-	-	-	-	-	-
4080	-	-	-	-	-	-	-	-	-	-

**Notes:**

Data Includes Pressure Drop Due To Wet Coils And Filters.

1.12 kW - Fan Motor Heat (kW) = 1.144 x Fan kW + 0.132

Factory Supplied Motors, In Commercial Equipment, Are Definite Purpose Motors, Specifically Designed And Tested To Operate Reliably And Continuously At All Cataloged Conditions. Using The Full Horsepower Range Of Our Fan Motors As Shown In Our Tabular Data Will Not Result In Nuisance Tripping Or Premature Motor Failure. Our Product's Warranty Will Not Be Affected.

**Table PD-10a – Belt Drive Evaporator Fan Performance WSC060AD,T Horizontal Configuration (IP)**

CFM	External Static Pressure (Inches of Water)																			
	0.10		0.20		0.30		0.40		0.50		0.60		0.70		0.80		0.90		1.00	
	RPM	BHP	RPM	BHP	RPM	BHP	RPM	BHP	RPM	BHP	RPM	BHP	RPM	BHP	RPM	BHP	RPM	BHP	RPM	BHP
	<b>1-1/2 HP Standard Motor &amp; Low Static Drive</b>								<b>1-1/2 HP Standard Motor &amp; Drive</b>											
1600	692	0.34	761	0.41	823	0.48	884	0.55	941	0.63	990	0.70	1034	0.78	1077	0.85	1119	0.93	1158	1.01
1800	761	0.47	825	0.54	882	0.62	937	0.70	992	0.78	1043	0.87	1088	0.95	1130	1.03	1169	1.12	1207	1.21
2000	831	0.62	891	0.70	945	0.78	995	0.87	1045	0.97	1094	1.06	1141	1.15	1185	1.25	1224	1.34	1260	1.43
2200	901	0.80	958	0.90	1009	0.98	1057	1.08	1101	1.18	1146	1.28	1192	1.38	1235	1.49	1277	1.59	1314	1.69
2400	972.8	1.02	1026	1.13	1075	1.22	1120	1.32	1163	1.42	1204	1.53	1245	1.65	-	-	-	-	-	-

**1-1/2 HP Standard Motor & Hi Static Drive**

CFM	External Static Pressure (Inches of Water)									
	1.10		1.20		1.30		1.40		1.50	
	RPM	BHP	RPM	BHP	RPM	BHP	RPM	BHP	RPM	BHP
	<b>1-1/2 HP Std Motor &amp; Drive</b>				<b>1-1/2 HP Standard Motor &amp; Hi Static Drive</b>					
1600	1196	1.09	1231	1.17	1265	1.26	1298	1.35	1330	1.44
1800	1244	1.29	1280	1.38	1314	1.47	1346	1.56	1380	1.66
2000	1295	1.52	1330	1.62	1363	1.72	-	-	-	-
2200	-	-	-	-	-	-	-	-	-	-
2400	-	-	-	-	-	-	-	-	-	-

**Notes:**

Data Includes Pressure Drop Due To Wet Coils And Filters.

1 1/2 HP - Fan Motor Heat (MBH) = 2.915 x Fan BHP + 0.451

Factory Supplied Motors, In Commercial Equipment, Are Definite Purpose Motors, Specifically Designed And Tested To Operate Reliably And Continuously At All Cataloged Conditions. Using The Full Horsepower Range Of Our Fan Motors As Shown In Our Tabular Data Will Not Result In Nuisance Tripping Or Premature Motor Failure. Our Product's Warranty Will Not Be Affected.



# Performance Data

**Table PD-11 – Belt Drive Evaporator Fan Performance WSC072AD,T Downflow Configuration (SI)**

m³/h	External Static Pressure (Pascals)																			
	25		50		75		100		125		150		175		200		225		250	
RPM	kW	RPM	kW	RPM	kW	RPM	kW	RPM	kW	RPM	kW	RPM	kW	RPM	kW	RPM	kW	RPM	kW	
<b>1.12 Nom kW Standard Motor &amp; Low Static Drive</b>										<b>1.12 Nom kW Standard Motor &amp; Drive</b>										
3260	-	-	541	0.22	603	0.28	657	0.33	705	0.38	751	0.44	794	0.50	835	0.56	874	0.62	912	0.68
3670	-	-	579	0.29	635	0.35	688	0.41	736	0.47	779	0.53	821	0.59	860	0.65	898	0.72	936	0.79
4080	565	0.31	620	0.37	670	0.43	720	0.50	768	0.56	810	0.63	850	0.70	888	0.76	925	0.83	961	0.91
4490	610	0.40	662	0.47	709	0.53	753	0.60	799	0.67	843	0.75	882	0.82	919	0.89	954	0.97	987	1.04
4890	657	0.51	705	0.58	749	0.64	791	0.72	832	0.79	874	0.88	914	0.96	950	1.04	985	1.12	1018	1.20

1.12 Nom kW Standard Motor & Hi Static Drive

m³/h	External Static Pressure (Pascals)									
	275		300		325		350		375	
RPM	kW	RPM	kW	RPM	kW	RPM	kW	RPM	kW	
<b>1.12 Nom kW Standard Motor &amp; Drive</b>				<b>1.12 Nom kW Standard Motor &amp; Hi Static Drive</b>						
3260	948	0.75	982	0.81	1015	0.87	1047	0.93	1079	0.99
3670	971	0.86	1004	0.93	1037	1.00	1069	1.07	1099	1.14
4080	995	0.98	1027	1.06	1060	1.13	1091	1.21	1121	1.29
4490	1021	1.12	1053	1.20	1085	1.28	1115	1.36	1145	1.45
4890	1050	1.28	1081	1.36	1112	1.44	1140	1.53	1170	1.62
<b>1.50 Nom kW Over-Sized Motor &amp; Hi Static Drive</b>										

Notes:  
 Data Includes Pressure Drop Due To Wet Coils And Filters.  
 1.12 kW - Fan Motor Heat (kW) = 1.144 x Fan kW + 0.132  
 1.50 kW - Fan Motor Heat (kW) = 1.178 x Fan kW + 0.464

Factory Supplied Motors, In Commercial Equipment, Are Definite Purpose Motors, Specifically Designed And Tested To Operate Reliably And Continuously At All Cataloged Conditions. Using The Full Horsepower Range Of Our Fan Motors As Shown In Our Tabular Data Will Not Result In Nuisance Tripping Or Premature Motor Failure. Our Product's Warranty Will Not Be Affected.

**Table PD-11a – Belt Drive Evaporator Fan Performance WSC072AD,T Downflow Configuration (IP)**

CFM	External Static Pressure (Inches of Water)																			
	0.10		0.20		0.30		0.40		0.50		0.60		0.70		0.80		0.90		1.00	
RPM	BHP	RPM	BHP	RPM	BHP	RPM	BHP	RPM	BHP	RPM	BHP	RPM	BHP	RPM	BHP	RPM	BHP	RPM	BHP	
<b>1-1/2 HP Standard Motor &amp; Low Static Drive</b>									<b>1-1/2 HP Standard Motor &amp; Drive</b>											
1920	-	-	541	0.30	603	0.37	657	0.44	705	0.51	751	0.59	794	0.67	835	0.75	874	0.83	912	0.92
2160	-	-	579	0.39	635	0.46	688	0.55	736	0.63	779	0.71	821	0.79	860	0.88	898	0.97	936	1.06
2400	565	0.42	620	0.49	670	0.57	720	0.66	768	0.76	810	0.84	850	0.93	888	1.02	925	1.12	961	1.22
2640	610	0.54	662	0.62	709	0.71	753	0.80	799	0.90	843	1.00	882	1.10	919	1.20	954	1.29	987	1.39
2880	657	0.68	705	0.78	749	0.86	791	0.96	832	1.06	874	1.17	914	1.28	950	1.39	985	1.50	1018	1.60

1-1/2 HP Standard Motor & Hi Static Drive

CFM	External Static Pressure (Inches of Water)									
	1.10		1.20		1.30		1.40		1.50	
RPM	BHP	RPM	BHP	RPM	BHP	RPM	BHP	RPM	BHP	
<b>1-1/2 HP Std Motor &amp; Hi Static Drive</b>				<b>1-1/2 HP Standard Motor &amp; Hi Static Drive</b>						
1920	948	1.00	982	1.08	1015	1.16	1047	1.25	1079	1.33
2160	971	1.15	1004	1.25	1037	1.34	1069	1.43	1099	1.52
2400	995	1.32	1027	1.42	1060	1.52	1091	1.62	1121	1.73
2640	1021	1.50	1053	1.60	1085	1.72	1115	1.83	1145	1.94
2880	1050	1.71	1081	1.82	1112	1.94	1140	2.05	1170	2.17
<b>2 HP Over-Sized Motor &amp; Hi Static Drive</b>										

Notes:  
 Data Includes Pressure Drop Due To Wet Coils And Filters.  
 1 1/2 HP - Fan Motor Heat (MBH) = 2.915 x Fan BHP + 0.451  
 2 HP - Fan Motor Heat (MBH) = 3.000 x Fan BHP + 0.500

Factory Supplied Motors, In Commercial Equipment, Are Definite Purpose Motors, Specifically Designed And Tested To Operate Reliably And Continuously At All Cataloged Conditions. Using The Full Horsepower Range Of Our Fan Motors As Shown In Our Tabular Data Will Not Result In Nuisance Tripping Or Premature Motor Failure. Our Product's Warranty Will Not Be Affected.



# Performance Data

**Table PD-12 – Belt Drive Evaporator Fan Performance WSC072AD,T Horizontal Configuration (SI)**

m³/h	External Static Pressure (Pascals)																			
	25		50		75		100		125		150		175		200		225		250	
	RPM	kW	RPM	kW	RPM	kW	RPM	kW	RPM	kW	RPM	kW	RPM	kW	RPM	kW	RPM	kW	RPM	kW
<b>1.12 Nom kW Standard Motor &amp; Low Static Drive</b>										<b>1.12 Nom kW Standard Motor &amp; Drive</b>										
3260	535	0.21	595	0.26	654	0.32	703	0.36	750	0.42	794	0.48	838	0.55	882	0.61	923	0.67	963	0.73
3670	590	0.29	638	0.34	695	0.40	745	0.46	789	0.51	830	0.58	871	0.65	910	0.72	950	0.79	987	0.86
4080	647	0.38	686	0.43	737	0.49	787	0.57	831	0.64	870	0.70	908	0.76	944	0.84	980	0.92	1015	0.99
4490	703	0.50	740	0.55	781	0.61	828	0.68	872	0.77	911	0.84	948	0.91	983	0.98	1016	1.06	1049	1.14
4890	761	0.64	795	0.70	828	0.76	871	0.83	913	0.91	953	1.00	990	1.08	1023	1.15	1055	1.23	1086	1.31
<b>1.12 Nom kW Standard Motor &amp; Drive</b>										<b>1.12 Nom kW Standard Motor &amp; Hi Static Drive</b>										

m³/h	External Static Pressure (Pascals)									
	275		300		325		350		375	
	RPM	kW	RPM	kW	RPM	kW	RPM	kW	RPM	kW
<b>1.12 Nom kW Standard Motor &amp; Hi Static Drive</b>										
3260	1002	0.80	1038	0.87	1073	0.94	1107	1.01	1140	1.09
3670	1025	0.93	1060	1.00	1096	1.07	1129	1.15	1162	1.23
4080	1051	1.07	1085	1.15	1118	1.23	1152	1.31	1185	1.39
4490	1081	1.23	1113	1.31	1146	1.40	1178	1.49	1208	1.57
4890	1117	1.40	1147	1.49	1178	1.59	1206	1.68	1236	1.77
<b>1.50 Nom kW Over-Sized Motor &amp; Hi Static Drive</b>										

**Notes:**

Data Includes Pressure Drop Due To Wet Coils And Filters.

1.12 kW - Fan Motor Heat (kW) = 1.144 x Fan kW + 0.132

1.50 kW - Fan Motor Heat (kW) = 1.178 x Fan kW + 0.464

Factory Supplied Motors, In Commercial Equipment, Are Definite Purpose Motors, Specifically Designed And Tested To Operate Reliably And Continuously At All Cataloged Conditions. Using The Full Horsepower Range Of Our Fan Motors As Shown In Our Tabular Data Will Not Result In Nuisance Tripping Or Premature Motor Failure. Our Product's Warranty Will Not Be Affected.

**Table PD-12a – Belt Drive Evaporator Fan Performance WSC072AD,T Horizontal Configuration (IP)**

CFM	External Static Pressure (Inches of Water)																			
	0.10		0.20		0.30		0.40		0.50		0.60		0.70		0.80		0.90		1.00	
	RPM	BHP	RPM	BHP	RPM	BHP	RPM	BHP	RPM	BHP	RPM	BHP	RPM	BHP	RPM	BHP	RPM	BHP	RPM	BHP
<b>1-1/2 HP Standard Motor &amp; Low Static Drive</b>								<b>1-1/2 HP Standard Motor &amp; Drive</b>												
1920	535	0.28	595	0.34	654	0.42	703	0.49	750	0.56	794	0.65	838	0.73	882	0.82	923	0.90	963	0.99
2160	590	0.39	638	0.45	695	0.53	745	0.62	789	0.69	830	0.77	871	0.87	910	0.96	950	1.06	987	1.15
2400	647	0.51	686	0.58	737	0.66	787	0.76	831	0.85	870	0.93	908	1.02	944	1.12	980	1.23	1015	1.33
2640	703	0.67	740	0.74	781	0.82	828	0.92	872	1.03	911	1.13	948	1.22	983	1.31	1016	1.42	1049	1.53
2880	761	0.85	795	0.94	828	1.02	871	1.11	913	1.22	953	1.34	990	1.45	1023	1.55	1055	1.65	1086	1.75
<b>1-1/2 HP Standard Motor &amp; Drive</b>								<b>1-1/2 HP Std Motor &amp; Hi Static Drive</b>												

CFM	External Static Pressure (Inches of Water)									
	1.10		1.20		1.30		1.40		1.50	
	RPM	BHP	RPM	BHP	RPM	BHP	RPM	BHP	RPM	BHP
<b>1-1/2 HP Standard Motor &amp; Hi Static Drive</b>										
1920	1002	1.08	1038	1.17	1073	1.27	1107	1.36	1140	1.46
2160	1025	1.25	1060	1.34	1096	1.44	1129	1.54	1162	1.65
2400	1051	1.44	1085	1.54	1118	1.64	1152	1.75	1185	1.86
2640	1081	1.65	1113	1.76	1146	1.88	1178	1.99	1208	2.10
2880	1117	1.88	1147	2.00	1178	2.13	1206	2.25	1236	2.38
<b>2 HP Over-Sized Motor &amp; Hi Static Drive</b>										

**Notes:**

Data Includes Pressure Drop Due To Wet Coils And Filters.

1 1/2 HP - Fan Motor Heat (MBH) = 2.915 x Fan BHP + 0.451

2 HP - Fan Motor Heat (MBH) = 3.000 x Fan BHP + 0.500

Factory Supplied Motors, In Commercial Equipment, Are Definite Purpose Motors, Specifically Designed And Tested To Operate Reliably And Continuously At All Cataloged Conditions. Using The Full Horsepower Range Of Our Fan Motors As Shown In Our Tabular Data Will Not Result In Nuisance Tripping Or Premature Motor Failure. Our Product's Warranty Will Not Be Affected.



# Performance Data

**Table PD-13 – Belt Drive Evaporator Fan Performance W/SC090AD,T Downflow Configuration (SI)**

m³/h	External Static Pressure (Pascals)																			
	25		50		75		100		125		150		175		200		225		250	
	RPM	kW	RPM	kW	RPM	kW	RPM	kW	RPM	kW	RPM	kW	RPM	kW	RPM	kW	RPM	kW	RPM	kW
	<b>1.50 Nom kW Standard Motor &amp; Low Static Drive</b>								<b>1.50 Nom kW Standard Motor &amp; Drive</b>											
4080	-	-	-	-	670	0.43	720	0.50	768	0.56	810	0.63	850	0.70	888	0.76	925	0.83	961	0.91
4590	-	-	673	0.49	719	0.55	763	0.63	807	0.70	850	0.78	889	0.85	926	0.93	961	1.00	995	1.08
5100	680	0.57	727	0.65	770	0.71	810	0.78	849	0.86	890	0.95	929	1.03	967	1.12	1000	1.20	1034	1.28
5610	739	0.73	782	0.83	823	0.90	861	0.97	897	1.05	933	1.12	969	1.23	1006	1.33	1041	1.42	1074	1.52
6120	798	0.94	838	1.04	876	1.12	913	1.20	947	1.28	980	1.37	1013	1.47	1047	1.57	1080	1.67	1113	1.77

1.50 Nom kW Standard Motor & Hi Static Drive

m³/h	External Static Pressure (Pascals)									
	275		300		325		350		375	
	RPM	kW	RPM	kW	RPM	kW	RPM	kW	RPM	kW
	<b>1.50 Nom kW Std Motor &amp; Drive</b>				<b>1.50 Nom kW Standard Motor &amp; Hi Static Drive</b>					
4080	995	0.98	1027	1.06	1060	1.13	1091	1.21	1121	1.29
4590	1027	1.15	1059	1.23	1091	1.32	1121	1.40	1151	1.49
5100	1065	1.36	1095	1.45	1125	1.53	1154	1.62	1183	1.71
5610	1104	1.60	1134	1.70	1163	1.79	1191	1.88	1217	1.97
6120	1144	1.88	1173	1.98	1202	2.08	1229	2.17	1256	2.27

2.24 Nom kW Over-Sized Motor & Hi Static Drive

**Notes:**

Data Includes Pressure Drop Due To Wet Coils And Filters.  
 1.50 kW - Fan Motor Heat (kW) = 1.178 x Fan kW + 0.464  
 2.24 kW - Fan Motor Heat (kW) = 1.138 x Fan kW + 0.139

Factory Supplied Motors, In Commercial Equipment, Are Definite Purpose Motors, Specifically Designed And Tested To Operate Reliably And Continuously At All Cataloged Conditions. Using The Full Horsepower Range Of Our Fan Motors As Shown In Our Tabular Data Will Not Result In Nuisance Tripping Or Premature Motor Failure. Our Product's Warranty Will Not Be Affected.

**Table PD-13a – Belt Drive Evaporator Fan Performance W/SC090AD,T Downflow Configuration (IP)**

CFM	External Static Pressure (Inches of Water)																			
	0.10		0.20		0.30		0.40		0.50		0.60		0.70		0.80		0.90		1.00	
	RPM	BHP	RPM	BHP	RPM	BHP	RPM	BHP	RPM	BHP	RPM	BHP	RPM	BHP	RPM	BHP	RPM	BHP	RPM	BHP
	<b>2 HP Standard Motor &amp; Low Static Drive</b>								<b>2 HP Standard Motor &amp; Drive</b>											
2400	-	-	-	-	670	0.57	720	0.66	768	0.76	810	0.84	850	0.93	888	1.02	925	1.12	961	1.22
2700	-	-	673	0.66	719	0.74	763	0.84	807	0.94	850	1.04	889	1.14	926	1.24	961	1.34	995	1.44
3000	680	0.76	727	0.87	770	0.95	810	1.05	849	1.16	890	1.27	929	1.38	967	1.50	1000	1.61	1034	1.72
3300	739	0.98	782	1.11	823	1.21	861	1.30	897	1.41	933	1.50	969	1.66	1006	1.78	1041	1.91	1074	2.03
3600	798	1.25	838	1.39	876	1.50	913	1.61	947	1.72	980	1.84	1013	1.97	1047	2.11	1080	2.24	1113	2.38

2 HP Standard Motor & Hi Static Drive

CFM	External Static Pressure (Inches of Water)									
	1.10		1.20		1.30		1.40		1.50	
	RPM	BHP	RPM	BHP	RPM	BHP	RPM	BHP	RPM	BHP
	<b>2 HP Standard Motor &amp; Drive</b>				<b>2 HP Standard Motor &amp; Hi Static Drive</b>					
2400	995	1.32	1027	1.42	1060	1.52	1091	1.62	1121	1.73
2700	1027	1.55	1059	1.65	1091	1.77	1121	1.88	1151	2.00
3000	1065	1.83	1095	1.94	1125	2.05	1154	2.17	1183	2.30
3300	1104	2.15	1134	2.27	1163	2.40	1191	2.52	1217	2.64
3600	1144	2.52	1173	2.65	1202	2.78	1229	2.91	1256	3.05

3 HP Over-Sized Motor & Hi Static Drive

**Notes:**

Data Includes Pressure Drop Due To Wet Coils And Filters.  
 2 HP - Fan Motor Heat (MBH) = 3.000 x Fan BHP + 0.500  
 3 HP - Fan Motor Heat (MBH) = 2.900 x Fan BHP + 0.475

Factory Supplied Motors, In Commercial Equipment, Are Definite Purpose Motors, Specifically Designed And Tested To Operate Reliably And Continuously At All Cataloged Conditions. Using The Full Horsepower Range Of Our Fan Motors As Shown In Our Tabular Data Will Not Result In Nuisance Tripping Or Premature Motor Failure. Our Product's Warranty Will Not Be Affected.

# Performance Data

**Table PD-14 – Belt Drive Evaporator Fan Performance WSC090AD,T Horizontal Configuration (SI)**

m³/h	External Static Pressure (Pascals)																			
	25		50		75		100		125		150		175		200		225		250	
	RPM	kW	RPM	kW	RPM	kW	RPM	kW	RPM	kW	RPM	kW	RPM	kW	RPM	kW	RPM	kW	RPM	kW
	<b>1.50 Nom kW Std Mtr &amp; Low Static Drive</b>						<b>1.50 Nom kW Standard Motor &amp; Drive</b>													
4080	-	-	686	0.43	737	0.49	787	0.57	831	0.64	870	0.70	908	0.76	944	0.84	980	0.92	1015	0.99
4590	718	0.53	753	0.59	792	0.65	839	0.72	882	0.80	922	0.88	958	0.95	992	1.02	1026	1.10	1058	1.18
5100	789	0.71	822	0.78	853	0.84	892	0.91	935	0.99	974	1.08	1011	1.18	1044	1.25	1076	1.33	1106	1.41
5610	862	0.93	892	1.01	921	1.08	951	1.15	988	1.22	1026	1.31	1062	1.42	1096	1.52	1129	1.61	1158	1.69
6120	934	1.20	963	1.28	990	1.35	1016	1.43	1045	1.51	1079	1.59	1115	1.69	1148	1.80	1180	1.91	1210	2.02
							<b>1.50 Nom kW Standard Motor &amp; Hi Static Drive</b>						<b>2.24 Nom kW OS Motor &amp; Hi Static Drive</b>							

m³/h	External Static Pressure (Pascals)									
	275		300		325		350		375	
	RPM	kW	RPM	kW	RPM	kW	RPM	kW	RPM	kW
	<b>1.50 Nom kW Standard Motor &amp; Hi Static Drive</b>									
4080	1051	1.07	1085	1.15	1118	1.23	1152	1.31	1185	1.39
4590	1090	1.27	1122	1.36	1153	1.45	1185	1.53	1216	1.62
5100	1136	1.49	1165	1.59	1194	1.68	1223	1.78	1251	1.88
5610	1187	1.78	1214	1.86	1242	1.96	1269	2.06	1296	2.17
6120	1239	2.12	1266	2.21	1291	2.30	1317	2.39	1343	2.49
	<b>2.24 Nom kW Over-Sized Motor &amp; Hi Static Drive</b>									

**Notes:**

Data Includes Pressure Drop Due To Wet Coils And Filters  
 1.50 kW - Fan Motor Heat (kW) = 1.178 x Fan kW + 0.464  
 2.24 kW - Fan Motor Heat (kW) = 1.138 x Fan kW + 0.139

Factory Supplied Motors, In Commercial Equipment, Are Definite Purpose Motors, Specifically Designed And Tested To Operate Reliably And Continuously At All Cataloged Conditions. Using The Full Horsepower Range Of Our Fan Motors As Shown In Our Tabular Data Will Not Result In Nuisance Tripping Or Premature Motor Failure. Our Product's Warranty Will Not Be Affected.

**Table PD-14a – Belt Drive Evaporator Fan Performance WSC090AD,T Horizontal Configuration (IP)**

CFM	External Static Pressure (Inches of Water)																			
	0.10		0.20		0.30		0.40		0.50		0.60		0.70		0.80		0.90		1.00	
	RPM	BHP	RPM	BHP	RPM	BHP	RPM	BHP	RPM	BHP	RPM	BHP	RPM	BHP	RPM	BHP	RPM	BHP	RPM	BHP
	<b>2 HP Standard Motor &amp; Low Static Drive</b>						<b>2 HP Standard Motor &amp; Drive</b>													
2400	-	-	686	0.58	737	0.66	787	0.76	831	0.85	870	0.93	908	1.02	944	1.12	980	1.23	1015	1.33
2700	718	0.71	753	0.79	792	0.87	839	0.96	882	1.08	922	1.18	958	1.27	992	1.36	1026	1.47	1058	1.59
3000	789	0.96	822	1.04	853	1.13	892	1.22	935	1.33	974	1.45	1011	1.58	1044	1.68	1076	1.78	1106	1.88
3300	862	1.25	892	1.35	921	1.44	951	1.54	988	1.64	1026	1.76	1062	1.90	1096	2.04	1129	2.16	1158	2.27
3600	934	1.61	963	1.71	990	1.81	1016	1.92	1045	2.02	1079	2.13	1115	2.27	1148	2.41	1180	2.57	1210	2.71
	<b>2 HP Standard Motor &amp; Static Drive</b>						<b>2 HP Std Motor &amp; Hi Static Drive</b>													

CFM	External Static Pressure (Inches of Water)									
	1.10		1.20		1.30		1.40		1.50	
	RPM	BHP	RPM	BHP	RPM	BHP	RPM	BHP	RPM	BHP
	<b>2 HP Standard Motor &amp; Hi Static Drive</b>									
2400	1051	1.44	1085	1.54	1118	1.64	1152	1.75	1185	1.86
2700	1090	1.70	1122	1.82	1153	1.94	1185	2.06	1216	2.18
3000	1136	2.00	1165	2.13	1194	2.26	1223	2.39	1251	2.52
3300	1187	2.39	1214	2.50	1242	2.63	1269	2.76	1296	2.90
3600	1239	2.84	1266	2.96	1291	3.08	1317	3.20	1343	3.34
	<b>3 HP Over-Sized Motor &amp; Hi Static Drive</b>									

**3 HP Over-Sized Motor & Hi Static Drive**

**Notes:**

Data Includes Pressure Drop Due To Wet Coils And Filters.  
 2 HP - Fan Motor Heat (MBH) = 3.000 x Fan BHP + 0.500  
 3 HP - Fan Motor Heat (MBH) = 2.900 x Fan BHP + 0.475

Factory Supplied Motors, In Commercial Equipment Are Definite Purpose Motors, Specifically Designed And Tested To Operate Reliably And Continuously At All Cataloged Conditions. Using The Full Horsepower Range Of Our Fan Motors As Shown In Our Tabular Data Will Not Result In Nuisance Tripping Or Premature Motor Failure. Our Product's Warranty Will Not Be Affected.



# Performance Data

**Table PD-15 – Belt Drive Evaporator Fan Performance WSC0120AD,T Downflow Configuration (SI)**

m³/h	External Static Pressure (Pascals)																			
	25		50		75		100		125		150		175		200		225		250	
	RPM	kW	RPM	kW	RPM	kW	RPM	kW	RPM	kW	RPM	kW	RPM	kW	RPM	kW	RPM	kW	RPM	kW
<b>2.24 Nom kW Standard Motor &amp; Low Static Drive</b>											<b>2.24 Nom kW Standard Motor &amp; Drive</b>									
5440	-	-	-	-	-	-	-	-	718	0.72	754	0.82	789	0.93	822	1.03	856	1.14	887	1.25
6120	-	-	-	-	694	0.71	731	0.81	764	0.90	797	0.99	829	1.10	860	1.22	892	1.34	922	1.46
6800	-	-	715	0.81	747	0.90	782	1.01	814	1.11	844	1.21	874	1.32	903	1.44	932	1.56	960	1.69
7480	741	0.95	773	1.04	803	1.14	834	1.24	864	1.36	894	1.48	922	1.59	948	1.70	975	1.82	1001	1.95
8160	803	1.21	833	1.31	861	1.42	887	1.52	916	1.64	947	1.77	972	1.90	997	2.02	1022	2.14	1046	2.27

m³/h	External Static Pressure (Pascals)																			
	275		300		325		350		375		400		425		450		475		500	
	RPM	kW	RPM	kW	RPM	kW	RPM	kW	RPM	kW	RPM	kW	RPM	kW	RPM	kW	RPM	kW	RPM	kW
<b>2.24 Nom kW Standard Motor &amp; Drive</b>											<b>2.24 Nom kW Standard Motor &amp; High Static Drive</b>									
5440	917	1.36	945	1.47	973	1.60	999	1.72	1024	1.84	1048	1.97	1072	2.10	1095	2.23	1117	2.37	1140	3.36
6120	951	1.57	979	1.69	1007	1.82	1033	1.94	1059	2.07	1082	2.20	1107	2.34	1130	2.49	1152	2.63	1173	3.71
6800	988	1.82	1015	1.95	1042	2.08	1068	2.21	1093	2.35	1117	2.48	1142	2.63	1164	2.76	1187	2.91	1209	4.11
7480	1028	2.09	1053	2.23	1078	2.38	1103	2.52	1128	2.66	1152	2.81	1176	2.95	1198	3.10	1221	3.25	-	-
8160	1071	2.41	1095	2.55	1119	2.70	1142	2.86	1166	3.02	1189	3.17	1212	3.33	-	-	-	-	-	-

Notes:  
 Data Includes Pressure Drop Due To Wet Coils And Filters.  
 2.24 kW - Fan Motor Heat (kW) = 1.138 x Fan kW + 0.139

Factory Supplied Motors, In Commercial Equipment, Are Definite Purpose Motors, Specifically Designed And Tested To Operate Reliably And Continuously At All Cataloged Conditions. Using The Full Horsepower Range Of Our Fan Motors As Shown In Our Tabular Data Will Not Result In Nuisance Tripping Or Premature Motor Failure. Our Product's Warranty Will Not Be Affected.

**Table PD-15a – Belt Drive Evaporator Fan Performance WSC0120AD,T Downflow Configuration (IP)**

CFM	External Static Pressure (Inches of Water)																			
	0.10		0.20		0.30		0.40		0.50		0.60		0.70		0.80		0.90		1.00	
	RPM	BHP	RPM	BHP	RPM	BHP	RPM	BHP	RPM	BHP	RPM	BHP	RPM	BHP	RPM	BHP	RPM	BHP	RPM	BHP
<b>3 HP Standard Motor &amp; Low Static Drive</b>											<b>3 HP Standard Motor &amp; Drive</b>									
3200	-	-	-	-	-	-	-	-	718	0.97	754	1.10	789	1.25	822	1.38	856	1.53	887	1.67
3600	-	-	-	-	694	0.95	731	1.08	764	1.20	797	1.33	829	1.48	860	1.63	892	1.79	922	1.95
4000	-	-	715	1.09	747	1.21	782	1.35	814	1.49	844	1.63	874	1.77	903	1.93	932	2.09	960	2.27
4400	741	1.27	773	1.40	803	1.53	834	1.67	864	1.82	894	1.98	922	2.13	948	2.28	975	2.44	1001	2.62
4800	803	1.62	833	1.76	861	1.90	887	2.04	916	2.20	947	2.38	972	2.55	997	2.71	1022	2.87	1046	3.04

CFM	External Static Pressure (Water)																			
	1.10		1.20		1.30		1.40		1.50		1.60		1.70		1.80		1.90		2.00	
	RPM	BHP	RPM	BHP	RPM	BHP	RPM	BHP	RPM	BHP	RPM	BHP	RPM	BHP	RPM	BHP	RPM	BHP	RPM	BHP
<b>3 HP Standard Motor &amp; Drive</b>											<b>3 HP Standard Motor &amp; High Static Drive</b>									
3200	917	1.82	945	1.97	973	2.14	999	2.30	1024	2.47	1048	2.65	1072	2.82	1095	3.00	1117	3.17	1140	3.36
3600	951	2.11	979	2.27	1007	2.43	1033	2.60	1059	2.78	1082	2.95	1107	3.14	1130	3.33	1152	3.52	1173	3.71
4000	988	2.44	1015	2.62	1042	2.79	1068	2.97	1093	3.15	1117	3.33	1142	3.52	1164	3.70	1187	3.91	1209	4.11
4400	1028	2.81	1053	3.00	1078	3.19	1103	3.38	1128	3.57	1152	3.77	1176	3.96	1198	4.15	1221	4.36	-	-
4800	1071	3.23	1095	3.42	1119	3.62	1142	3.83	1166	4.04	1189	4.25	1212	4.46	-	-	-	-	-	-

Notes:  
 Data Includes Pressure Drop Due To Wet Coils And Filters.  
 3 HP - Fan Motor Heat (MBH) = 2.900 x Fan BHP + 0.475

Factory Supplied Motors, In Commercial Equipment, Are Definite Purpose Motors, Specifically Designed And Tested To Operate Reliably And Continuously At All Cataloged Conditions. Using The Full Horsepower Range Of Our Fan Motors As Shown In Our Tabular Data Will Not Result In Nuisance Tripping Or Premature Motor Failure. Our Product's Warranty Will Not Be Affected.

# Performance Data

**Table PD-16 – Belt Drive Evaporator Fan Performance WSC0120AD,T Horizontal Configuration (SI)**

External Static Pressure (Pascals)																				
m³/h	25		50		75		100		125		150		175		200		225		250	
	RPM	kW	RPM	kW	RPM	kW	RPM	kW	RPM	kW	RPM	kW	RPM	kW	RPM	kW	RPM	kW	RPM	kW
<b>2.24 Nom kW Standard Motor &amp; Low Static Drive</b>										<b>2.24 Nom kW Standard Motor &amp; Drive</b>										
5440	-	-	691	0.67	730	0.75	771	0.84	807	0.94	844	1.04	886	1.16	926	1.28	965	1.41	1000	1.53
6120	729	0.84	761	0.91	792	0.99	829	1.08	865	1.19	898	1.30	930	1.41	965	1.53	1002	1.67	1038	1.81
6800	802	1.13	833	1.22	860	1.29	890	1.38	923	1.50	956	1.62	986	1.72	1015	1.85	1044	1.98	1077	2.12
7480	876	1.49	905	1.58	931	1.67	955	1.75	983	1.86	1014	1.99	1045	2.12	1072	2.25	1098	2.37	1125	2.51
8160	950	1.91	977	2.02	1002	2.11	1025	2.20	1048	2.30	1074	2.42	1102	2.56	1131	2.71	1156	2.84	1181	2.98
										<b>2.24 Nom kW Standard Motor &amp; High Static Drive</b>										

External Static Pressure (Pascals)																				
m³/h	275		300		325		350		375		400		425		450		475		500	
	RPM	kW	RPM	kW	RPM	kW	RPM	kW	RPM	kW	RPM	kW	RPM	kW	RPM	kW	RPM	kW	RPM	kW
<b>2.24 Nom kW Standard Motor &amp; Drive</b>										<b>2.24 Nom kW Standard Motor &amp; High Static Drive</b>										
5440	1029	1.64	1057	1.75	1084	1.86	1108	1.96	1132	2.06	1155	2.17	1177	2.27	1198	2.37	1219	2.48	1239	3.46
6120	1072	1.95	1106	2.10	1134	2.22	1160	2.35	1185	2.47	1209	2.59	1231	2.70	1252	2.82	1274	2.94	1295	4.10
6800	1111	2.28	1143	2.43	1174	2.58	1204	2.74	1232	2.90	1260	3.05	1283	3.18	1306	3.32	-	-	-	-
7480	1152	2.65	1182	2.81	1211	2.97	1241	3.14	1270	3.31	-	-	-	-	-	-	-	-	-	-
8160	1205	3.12	1229	3.27	-	-	-	-	-	-	-	-	-	-	-	-	-	-	-	-

**Notes:**

Data Includes Pressure Drop Due To Wet Coils And Filters.

2.24 kW - Fan Motor Heat (kW) = 1.138 x Fan kW + 0.139

Factory Supplied Motors, In Commercial Equipment, Are Definite Purpose Motors, Specifically Designed And Tested To Operate Reliably And Continuously At All Cataloged Conditions. Using The Full Horsepower Range Of Our Fan Motors As Shown In Our Tabular Data Will Not Result In Nuisance Tripping Or Premature Motor Failure. Our Product's Warranty Will Not Be Affected.

**Table PD-16a – Belt Drive Evaporator Fan Performance WSC0120AD,T Horizontal Configuration (IP)**

External Static Pressure (Inches of Water)																				
CFM	0.10		0.20		0.30		0.40		0.50		0.60		0.70		0.80		0.90		1.00	
	RPM	BHP	RPM	BHP	RPM	BHP	RPM	BHP	RPM	BHP	RPM	BHP	RPM	BHP	RPM	BHP	RPM	BHP	RPM	BHP
<b>3 HP Standard Motor &amp; Low Static Drive</b>										<b>3 HP Standard Motor &amp; Drive</b>										
3200	-	-	691	0.89	730	1.00	771	1.13	807	1.26	844	1.39	886	1.55	926	1.72	965	1.89	1000	2.06
3600	729	1.13	761	1.22	792	1.32	829	1.45	865	1.60	898	1.74	930	1.89	965	2.06	1002	2.24	1038	2.43
4000	802	1.52	833	1.63	860	1.73	890	1.86	923	2.01	956	2.17	986	2.30	1015	2.48	1044	2.65	1077	2.85
4400	876	1.99	905	2.12	931	2.24	955	2.35	983	2.49	1014	2.66	1045	2.84	1072	3.01	1098	3.18	1125	3.36
4800	950	2.56	977	2.70	1002	2.84	1025	2.96	1048	3.08	1074	3.24	1102	3.43	1131	3.63	1156	3.81	1181	4.00
										<b>3 HP Standard Motor &amp; High Static Drive</b>										

External Static Pressure (Water)																				
CFM	1.10		1.20		1.30		1.40		1.50		1.60		1.70		1.80		1.90		2.00	
	RPM	BHP	RPM	BHP	RPM	BHP	RPM	BHP	RPM	BHP	RPM	BHP	RPM	BHP	RPM	BHP	RPM	BHP	RPM	BHP
<b>3 HP Std Motor &amp; Drive</b>										<b>3 HP Standard Motor &amp; High Static Drive</b>										
3200	1029	2.20	1057	2.35	1084	2.49	1108	2.63	1132	2.77	1155	2.91	1177	3.05	1198	3.18	1219	3.32	1239	3.46
3600	1072	2.62	1106	2.81	1134	2.98	1160	3.15	1185	3.31	1209	3.47	1231	3.63	1252	3.78	1274	3.94	1295	4.10
4000	1111	3.05	1143	3.26	1174	3.47	1204	3.68	1232	3.88	1260	4.09	1283	4.27	1306	4.46	-	-	-	-
4400	1152	3.55	1182	3.76	1211	3.99	1241	4.21	1270	4.44	-	-	-	-	-	-	-	-	-	-
4800	1205	4.19	1229	4.39	-	-	-	-	-	-	-	-	-	-	-	-	-	-	-	-

**Notes:**

Data Includes Pressure Drop Due To Wet Coils And Filters.

3 HP - Fan Motor Heat (MBH) = 2.900 x Fan BHP + 0.475

Factory Supplied Motors, In Commercial Equipment, Are Definite Purpose Motors, Specifically Designed And Tested To Operate Reliably And Continuously At All Cataloged Conditions. Using The Full Horsepower Range Of Our Fan Motors As Shown In Our Tabular Data Will Not Result In Nuisance Tripping Or Premature Motor Failure. Our Product's Warranty Will Not Be Affected.



# Performance Data

**Table PD-17 – Standard Motor & Sheave/Fan Speed (RPM)**

Unit	6 Turns	5 Turns	4 Turns	3 Turns	2 Turns	1 Turn	
Model No.	Open	Open	Open	Open	Open	Open	Closed
WSC060AD,T	N/A	898	967	1036	1105	1174	1243
WSC072AD,T	N/A	698	751	806	859	913	967
WSC090AD,T	N/A	752	806	860	914	968	1020
WSC120AD,T	N/A	782	838	894	950	1006	1062

Factory set at 3 turns open

**Table PD-18 – Standard Motor & Low Static Drive Accessory Sheave/Fan Speed (RPM)**

Unit	6 Turns	5 Turns	4 Turns	3 Turns	2 Turns	1 Turn	
Model No.	Open	Open	Open	Open	Open	Open	Closed
WSC060AD,T	N/A	691	760	829	898	967	1036
WSC072AD,T	N/A	537	590	644	698	752	806
WSC090AD,T	N/A	671	714	757	800	843	886
WSC120AD,T	N/A	717	754	799	844	885	922

Factory set at 3 turns open

**Table PD-19 – Standard Motor & High Static Drive Accessory Sheave/Fan Speed (RPM)**

Unit	6 Turns	5 Turns	4 Turns	3 Turns	2 Turns	1 Turn	
Model No.	Open	Open	Open	Open	Open	Open	Closed
WSC060AD,T	N/A	1243	1311	1379	1450	1515	1588
WSC072AD,T	N/A	967	1021	1075	1128	1183	1235
WSC090AD,T	1020	1073	1127	1181	1235	1289	N/A
WSC120AD,T	1062	1118	1174	1229	1285	1341	N/A

Factory set at 3 turns open

**Table PD-20 – Over-Sized Motor & Drive Sheave/Fan Speed (RPM)**

Unit	6 Turns	5 Turns	4 Turns	3 Turns	2 Turns	1 Turn	
Model No.	Open	Open	Open	Open	Open	Open	Closed
WSC072AD,T	N/A	967	1021	1075	1128	1183	1235
WSC090AD,T	1112	1182	1252	1322	1392	1460	N/A
WSC120AD,T	N/A	N/A	N/A	N/A	N/A	N/A	N/A

Factory set at 3 turns open

**Table PD-21 – Sound Power Level - dB (ref. 10<sup>-12</sup> Watts)**

Unit	Octave Center Frequency								Overall dBA
	63	125m	250	500	1000m	2000	4000	8000	
WSC060AD,T	84	91m	79	77	74	71	68	63	80
WSC072AD,T	83	90	86	82	79	75	70	63	85
WSC090AD,T	83	90	86	83	80	75	71	64	85
WSC120AD,T	83	86	80	77	73	69	66	60	79

Note:  
Tests follow ARI270-95.

# Performance Data

**Table PD-22 - Static Pressure Drops Through Accessories - (Pascals)**

Unit Model No.	Airflow (m <sup>3</sup> /h)	Standard Filters <sup>1</sup>	Pleated Filters 50 mm (2 inch)	Economizer with OA/RA Dampers <sup>2</sup>				Electric Heater Accessory (kW) <sup>3</sup>		
				100% OA	100% RA	100% OA	100% RA	7-9	10-27	37-40
				Downflow		Horizontal				
WSC060AD,T	2720	25	37	30	11	30	4	11	13	-
	3400	37	55	46	17	46	6	17	21	-
	4080	55	72	64	26	64	9	25	30	-
WSC072AD,T	3260	10	17	25	2	15	5	-	5	-
	4080	15	22	27	5	20	5	-	8	-
	4890	22	30	33	10	25	10	-	13	-
WSC090AD,T	4080	15	22	27	5	20	5	-	8	-
	5100	25	32	35	12	30	12	-	16	-
	6120	35	45	52	17	62	20	-	25	-
WSC120AD,T	5440	17	25	42	12	35	12	-	9	10
	6800	27	37	65	17	75	20	-	14	17
	8160	40	50	85	22	87	25	-	20	26

**Notes:**

1. Tested with standard filters. The WSC060AD,T has 25 mm (1 inch) standard filters. The WSC072AD,T - 120AD,T has 50 mm (2 inch) standard filters. The difference in pressure drop should be considered when utilizing optional 50 mm (2 inch) pleated filters.
2. OA = Outside Air and RA = Return Air
3. Nominal kW ratings at 380 V

**Table PD-22a - Static Pressure Drops Through Accessories - (Inches of Water Column)**

Unit Model No.	Airflow (CFM)	Standard Filters <sup>1</sup>	Pleated Filters 50 mm (2 inch)	Economizer with OA/RA Dampers <sup>2</sup>				Electric Heater Accessory (kW) <sup>3</sup>		
				100% OA	100% RA	100% OA	100% RA	7-9	10-27	37-40
				Downflow		Horizontal				
WSC060AD,T	1600	0.10	0.15	0.12	0.04	0.12	0.01	0.045	0.053	-
	2000	0.15	0.22	0.18	0.07	0.18	0.02	0.070	0.083	-
	2400	0.22	0.29	0.26	0.10	0.26	0.04	0.100	0.120	-
WSC072AD,T	1920	0.04	0.07	0.10	0.01	0.06	0.02	-	0.021	-
	2400	0.06	0.09	0.11	0.02	0.08	0.02	-	0.034	-
	2880	0.09	0.12	0.13	0.04	0.10	0.04	-	0.052	-
WSC090AD,T	2400	0.06	0.09	0.11	0.02	0.08	0.02	-	0.034	-
	3000	0.10	0.13	0.14	0.05	0.12	0.05	-	0.063	-
	3600	0.14	0.18	0.21	0.07	0.25	0.08	-	0.102	-
WSC120AD,T	3200	0.07	0.10	0.17	0.05	0.14	0.05	-	0.036	0.042
	4000	0.11	0.15	0.26	0.07	0.30	0.08	-	0.056	0.070
	4800	0.16	0.20	0.34	0.09	0.35	0.10	-	0.081	0.106

**Notes:**

1. Tested with standard filters. The WSC060AD,T has 25 mm (1 inch) standard filters. The WSC072AD,T - 120AD,T has 50 mm (2 inch) standard filters. The difference in pressure drop should be considered when utilizing optional 50 mm (2 inch) pleated filters.
2. OA = Outside Air and RA = Return Air
3. Nominal kW ratings at 380 V

**Table PD-23 - Electric Heater Voltage Correction Factors (Apply to Auxiliary Heat Capacity)**

Nominal Voltage	Distribution Voltage	Capacity Multiplier
200	200	1.00
415	380	0.84
	400	0.93
	415	1.00



# Performance Data

**Table PD-24 – Auxiliary Electric Heat Capacity**

Unit Model No.	Total <sup>2</sup>	No. Stages	Stage 1	Stage 2
	kW		kW	kW
WSC060AT	8.3	2	4.2	4.2
	12.1	2	6.0	6.0
	16	2	9.9	6.0
WSC060AD	7.5 / 9.0	2	3.75 / 4.5	3.75 / 4.5
	10.9 / 13.0	2	5.45 / 6.5	5.45 / 6.5
	14.4 / 17.2	2	8.95 / 10.7	5.45 / 6.5
WSC072AT	12.5	1	12.5	
	18.8	2	12.5	6.3
	25	2	12.5	12.5
WSC072AD	11.3 / 13.5	1	11.3 / 13.5	- -
	16.9 / 20.2	2	11.3 / 13.5	5.6 / 6.7
	22.6 / 26.9	2	11.3 / 13.5	11.3 / 13.5
WSC090AT	12.5	1	12.5	
	18.8	2	12.5	6.3
	25	2	12.5	12.5
WSC090AD	11.3 / 13.5	1	11.3 / 13.5	- -
	16.9 / 20.2	2	11.3 / 13.5	5.6 / 6.7
	22.6 / 26.9	2	11.3 / 13.5	11.3 / 13.5
WSC120AT	18.8	2	12.5	6.3
	25	2	12.5	12.5
	37.5	2	25.0	12.5
WSC120AD	16.9 / 20.2	2	11.3 / 13.8	5.6 / 6.7
	22.6 / 26.9	2	11.3 / 13.9	11.3 / 13.5
	33.9 / 40.4	2	11.3 / 13.10	22.5 / 26.9

Notes:

1. Does not include indoor fan power or heat

2. Heaters are rated at 200V, and 380V / 415V. For other than rated voltage, CAP = (Voltage/Rated Voltage)<sup>2</sup> x Rated Cap.

**Table PD-24a – Auxiliary Electric Heat Capacity**

Unit Model No.	Total <sup>2</sup>	No. Stages	Stage 1	Stage 2
	MBH		MBH	MBH
WSC060AT	28	2	14	14
	41	2	20	20
	55	2	34	20
WSC060AD	26 / 31	2	13 / 16	13 / 16
	38 / 45	2	19 / 23	19 / 23
	50 / 59	2	31 / 37	19 / 23
WSC072AT	43	1	43	- -
	64	2	43	22
	85	2	43	43
WSC072AD	39 / 47	1	39 / 47	- -
	58 / 69	2	39 / 47	20 / 23
	78 / 92	2	39 / 47	39 / 47
WSC090AT	43	1	43	- -
	64	2	43	22
	85	2	43	43
WSC090AD	39 / 47	1	39 / 47	- -
	58 / 69	2	39 / 47	20 / 23
	78 / 92	2	39 / 47	39 / 47
WSC120AT	64	2	43	22
	85	2	43	43
	123	2	85	43
WSC120AD	58 / 69	2	39 / 47	20 / 23
	78 / 92	2	39 / 47	39 / 47
	116 / 138	2	39 / 47	77 / 92

Notes:

1. Does not include indoor fan power or heat

2. Heaters are rated at 200V, and 380V / 415V. For other than rated voltage, CAP = (Voltage/Rated Voltage)<sup>2</sup> x Rated Cap.



# Performance Data

**Table PD-25 – Air Temperature Rise Across Electric Heaters (Degrees C)**

kW	Stages	5 Ton	6 Ton	7.5 Ton	10 Ton
		3400 M <sup>3</sup> /H WSC060AD, T	4100 M <sup>3</sup> /H WSC072AD, T	5100 M <sup>3</sup> /H WSC090AD, T	6800 M <sup>3</sup> /H WSC120AD, T
7.5	2	6.6	-	-	-
8.3	2	7.3	-	-	-
9.0	2	7.9	-	-	-
10.9	2	9.6	-	-	-
11.3	1	-	8.3	6.6	-
12.1	2	10.6	-	-	-
12.5	1	-	9.1	7.3	-
13.0	2	11.4	-	-	-
13.5	1	-	9.9	7.9	-
14.4	2	12.6	-	-	-
16.0	2	14.0	-	-	-
16.9	2	-	12.4	9.9	7.4
17.2	2	15.1	-	-	-
18.8	2	-	13.8	11.0	8.3
20.2	2	-	14.8	11.8	8.9
22.6	2	-	16.5	13.2	9.9
25.0	2	-	18.3	14.6	11.0
26.9	2	-	19.7	15.7	11.8
33.9	2	-	-	-	14.9
37.5	2	-	-	-	16.5
40.4	2	-	-	-	17.7

Note:

For minimum design airflow, see performance table for each unit.

To calculate temp rise at different airflow, use following formula:

$$\text{Temp. Rise (C°) across Elect Htr} = (\text{kW} \times 2985) / (\text{M}^3/\text{H})$$

**Table PD-25a – Air Temperature Rise Across Electric Heaters (Degrees F)**

kW	Stages	5 Ton	6 Ton	7.5 Ton	10 Ton
		2000 CFM WSC060AD, T	2400 CFM WSC072AD, T	3000 CFM WSC090AD, T	4000 CFM WSC120AD, T
7.5	2	11.9	-	-	-
8.3	2	13.1	-	-	-
9.0	2	14.2	-	-	-
10.9	2	17.2	-	-	-
11.3	1	-	14.9	11.9	-
12.1	2	19.1	-	-	-
12.5	1	-	16.5	13.2	-
13.0	2	20.5	-	-	-
13.5	1	-	17.8	14.2	-
14.4	2	22.8	-	-	-
16.0	2	25.3	-	-	-
16.9	2	-	22.3	17.8	13.4
17.2	2	27.2	-	-	-
18.8	2	-	24.8	19.8	14.9
20.2	2	-	26.6	21.3	16.0
22.6	2	-	29.8	23.8	17.9
25.0	2	-	32.9	26.3	19.8
26.9	2	-	35.4	28.3	21.3
33.9	2	-	-	-	26.8
37.5	2	-	-	-	29.6
40.4	2	-	-	-	31.9

NOTE:

For minimum design airflow, see performance table for each unit.

To calculate temp rise at different airflow, use following formula:

$$\text{Temp. Rise (F°) across Elect Htr} = (\text{kW} \times 3414) / (1.08 \times \text{CFM})$$

**Table PD-26 – Electric Heater Temperature Rise Correction Factors**

% Variation From Nominal Airflow	- 20	- 15	- 10	- 5	0	+ 5	+ 10	+ 15	+ 20
Temperature Rise Multiplier	1.25	1.17	1.11	1.05	1	0.95	0.91	0.87	0.83

# Controls

## Field-Installed Control Options

**Zone Sensors** are the building occupant's comfort control devices available for Precedent® units.

**Manual Changeover** — Heat, Cool or Off System Switch. Fan Auto or Off Switch. One temperature setpoint lever.

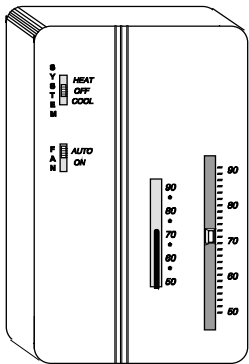

**Manual/Automatic Changeover** — Auto, Heat, Cool or Off System Switch. Fan Auto or Off Switch. Two temperature setpoint levers. Optional Status Indication LED lights, System On, Heat, Cool, or Service.

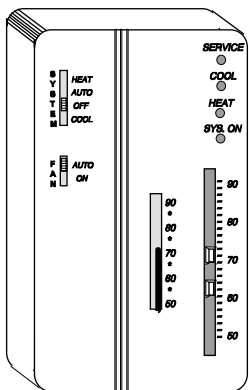

**Remote Sensor** — Sensor(s) available for all zone sensors to provide remote sensing capabilities.

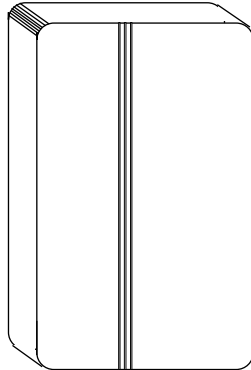

**Non-Programmable Manual/Auto** — Change over with digital LCD display - Auto, Heat, Cool, Emergency, Heat, or Off mode selection button. Status Indication LCD indicators - System On, Heat, Cool, or Service.

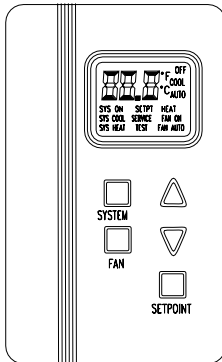

LCD indicators - System On, Heat, Cool, or Service

**Programmable Night Setback** — Auto or manual changeover with seven-day programming. Keyboard selection of Heat, Cool, Fan, Auto, or On.

All programmable sensors have System On, Heat, Cool, Service LED/indicators as standard. Night Setback Sensors have one (1) Occupied, one (1) Unoccupied, and two (2) Override programs per day.

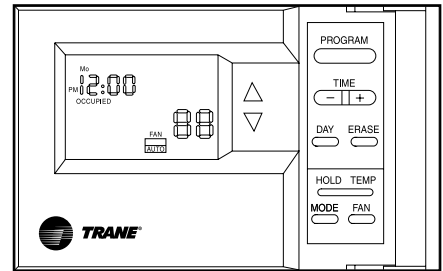

**Integrated Comfort® System** — Sensor(s) available with optional temperature adjustment and override buttons to provide central control through a Trane Integrated Comfort® system.

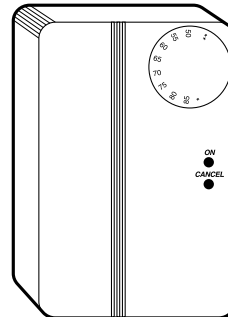

# Electrical Data

**Table ED-1 – Unit Wiring**

Unit Model No.	Unit Operating Voltage Range	Standard Indoor Fan Motor		Oversize Indoor Fan Motor	
		Minimum Circuit Ampacity	Maximum Fuse Size Or Maximum Circuit Breaker <sup>1</sup>	Minimum Circuit Ampacity	Maximum Fuse Size Or Maximum Circuit Breaker <sup>1</sup>
WSC060AD	342-456	18.9	25	18.9	25
WSC060AT	180-220	37.2	50	37.2	50
WSC072AD	342-456	21.9	30	22.9	30
WSC072AT	180-220	38.4	60	43.9	60
WSC090AD	342-456	24.8	35	26.5	35
WSC090AT	180-220	47.6	60	50.2	60
WSC120AD	342-456	31.2	40	31.2	40
WSC120AT	180-220	59.5	60	59.5	60

**Notes:**

1. All units to be installed under local codes.



# Electrical Data

**Table ED-2 – Unit Wiring With Electric Heat Single Point Connection – 380- 415 Volts**

Unit Model No.	Heater Model No.	Heater <sup>2</sup>		Control Stages	Standard Indoor Fan Motor		Oversized Indoor Fan Motor	
		kW Rating	MBH		Minimum Circuit Ampacity	Maximum Fuse Size Or Maximum Circuit Breaker <sup>1</sup>	Minimum Circuit Ampacity	Maximum Fuse Size Or Maximum Circuit Breaker <sup>1</sup>
380 / 415 Volts								
WSC060AD	BAYHTRR412A	7.5 / 9.0	26 / 31	2	33.3 / 34.6	40 / 40	-	-
	BAYHTRR418A	10.9 / 13.0	38 / 45	2	39.7 / 41.6	45 / 45	-	-
	BAYHTRR423A	14.4 / 17.2	50 / 59	2	46.3 / 48.8	50 / 50	-	-
WSC072AD	BAYHTRS418A	11.3 / 13.5	39 / 47	1	43.4 / 45.4	50 / 50	44.4 / 46.4	50 / 50
	BAYHTRS427A	16.9 / 20.2	58 / 69	2	54.1 / 57.1	60 / 60	55.1 / 58.1	60 / 60
	BAYHTRS436A	22.6 / 26.9	78 / 92	2	64.8 / 68.7	70 / 70	65.8 / 69.7	70 / 70
WSC090AD	BAYHTRS418A	11.3 / 13.5	39 / 47	1	46.3 / 48.3	50 / 50	48.0 / 50.0	50 / 50
	BAYHTRS427A	16.9 / 20.2	58 / 69	2	56.9 / 59.9	60 / 60	58.6 / 61.6	60 / 60
	BAYHTRS436A	22.6 / 26.9	78 / 92	2	67.7 / 71.6	70 / 70	69.4 / 73.3	70 / 70
WSC120AD	BAYHTRT427A	16.9 / 20.2	58 / 69	2	63.3 / 66.3	70 / 70	-	-
	BAYHTRT436A	22.6 / 26.9	78 / 92	2	74.0 / 77.9	80 / 80	-	-
	BAYHTRT454A	33.9 / 40.4	116 / 138	2	95.5 / 101.4	100 / 110	-	-

Notes:

1. All units to be installed under local codes
2. kW shown for 380V / 415V

**Table ED-3 – Unit Wiring With Electric Heat Single Point Connection – 200 Volts**

Unit Model No.	Heater Model No.	Heater <sup>2</sup>		Control Stages	Standard Indoor Fan Motor		Oversized Indoor Fan Motor	
		kW Rating	MBH		Minimum Circuit Ampacity	Maximum Fuse Size Or Maximum Circuit Breaker <sup>1</sup>	Minimum Circuit Ampacity	Maximum Fuse Size Or Maximum Circuit Breaker <sup>1</sup>
200 Volts								
WSC060AT	BAYHTRR312AA	8.3	28	2	67.2	80	-	-
	BAYHTRR318AA	12.1	41	2	80.9	90	-	-
	BAYHTRR323AA	16.0	55	2	95.0	100	-	-
WSC072AT	BAYHTRS318AA	12.5	43	1	86.4	100	89.1	100
	BAYHTRS327AA	18.8	64	2	109.1	110	111.8	125
	BAYHTRS336AA	25.0	85	2	131.5	150	134.2	150
WSC090AT	BAYHTRS318AA	12.5	43	1	92.7	100	95.3	100
	BAYHTRS327AA	18.8	64	2	115.4	125	118.0	125
	BAYHTRS336AA	25.0	85	2	137.8	150	140.4	150
WSC120AT	BAYHTRT327AA	18.8	64	2	127.4	150	-	-
	BAYHTRT336AA	25.0	85	2	149.7	150	-	-
	BAYHTRT354AA	37.5	123	2	194.9	200	-	-

Notes:

1. All units to be installed under local codes
2. kW shown for 380V / 415V

# Electrical Data

**Table ED-4 – Electrical Characteristics - Evaporator Fan Motor - 50 Hz**

Unit	Standard Evaporator Fan Motor						Oversized Evaporator Fan Motor						
	Model No.	No.	Volts	Phase	HP	Amps		No.	Volts	Phase	HP	Amps	
						FLA	LRA					FLA	LRA
WSC060AD	1		380-415	3	1.5	4.3	25.3	-	-	-	-	-	-
WSC060AT	1		200	3	1.5	8.1	48.0	-	-	-	-	-	-
WSC072AD	1		380-415	3	1.5	4.3	25.3	1	380-415	3	2.0	5.3	36.4
WSC072AT	1		200	3	1.5	8.1	48.0	1	200	3	2.0	10.8	69.0
WSC090AD	1		380-415	3	2.0	5.3	36.4	1	380-415	3	3.0	7.0	57.0
WSC090AT	1		200	3	2.0	10.8	69.0	1	200	3	3.0	13.4	108
WSC120AD	1		380-415	3	3.0	7.0	57.0	-	-	-	-	-	-
WSC120AT	1		200	3	3.0	13.4	108	-	-	-	-	-	-

**Table ED-5 – Electrical Characteristics - Compressor Motor And Condenser Motor - 50 Hz**

Unit	Compressor Motor							Condenser Fan Motor					
	Model No.	No.	Volts	Phase	HP <sup>1</sup>	RPM	Amps		No.	Phase	HP	Amps	
							RLA <sup>1</sup>	LRA <sup>1</sup>				FLA	LRA
WSC060AD	1		380-415	3	6	2875	10.9	74.00	1	3	0.40	1.9	2.8
WSC072AD	1		380-415	3	6.8	2875	11.7	101.00	1	3	0.75	2.8	7.1
WSC090AD	1		380-415	3	8.3	2875	13.2	91.00	1	3	0.75	2.8	7.1
WSC120AD	2		380-415	3	5.7 / 5.7	2875	9.4 / 9.4	74 / 74	1	3	0.75	2.8	7.1

Note:

1. Comp1 / Comp2

# Jobsite Connections

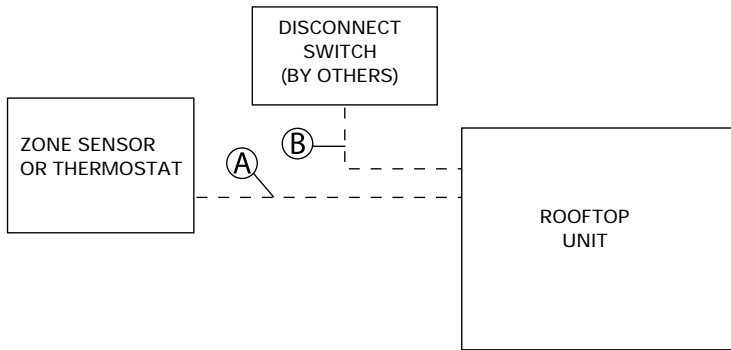

## Zone Sensors – Typical Number Of Wires

A - Manual Changeover	4
Manual/Auto Changeover	5
Manual/Auto Changeover with Status Indication LED's	10
Programmable Night Setback with Status Indication LED's	7

## Thermostats – Typical Number of Wires

A - 3 wires, 24-volts, Cooling Only
4 wires, 24-volts, with Electric Heat
B - 3 Power Wires + 1 Ground Wire (three phase)
2 Power Wires + 1 Ground Wire (single phase)

For specific wiring information, see the installation instructions.

All wiring except power wires is low voltage.

All customer supplied wiring to be copper and must conform to NEC or CEC and local electrical codes. Wiring shown dotted is to be furnished and installed by the customer.

# Dimensional Data

## WSC060

All dimensions are in inches/millimeters.

### WSC060

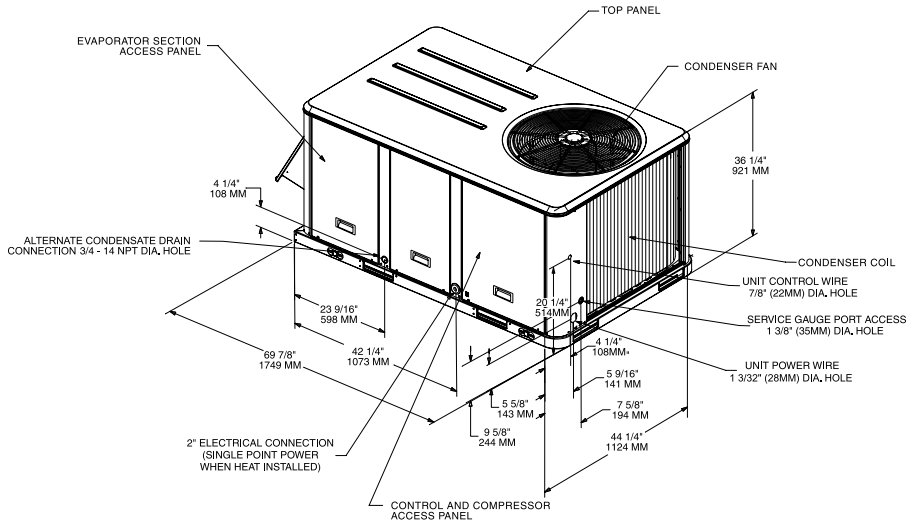

### WSC060 – Downflow Airflow Supply/Return

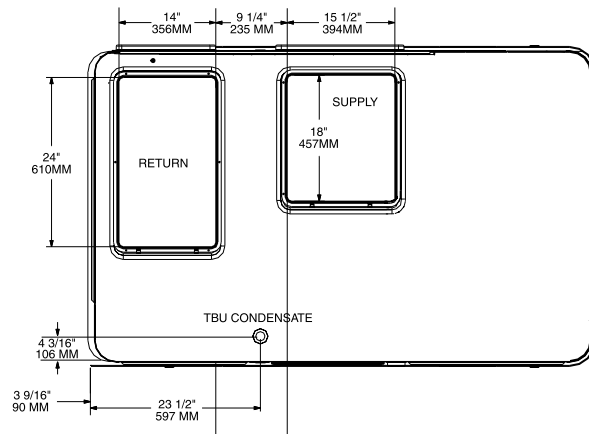

### WSC060 – Horizontal Airflow Supply/Return

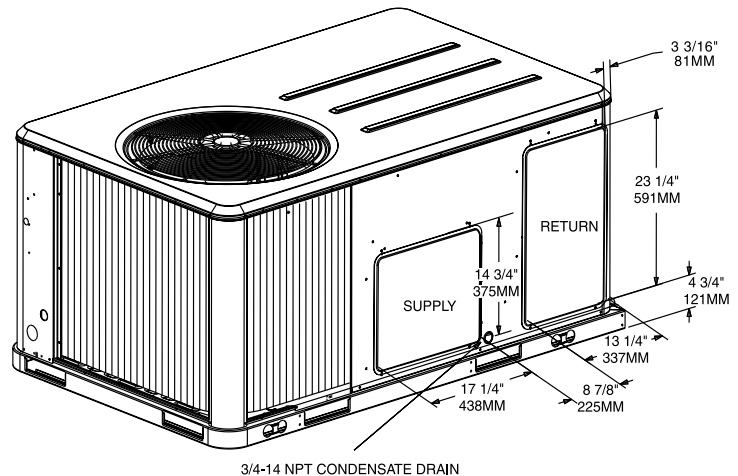

# Dimensional Data

## WSC060

All dimensions are in inches/millimeters.

### WSC060 – Unit Clearance and Roof Opening

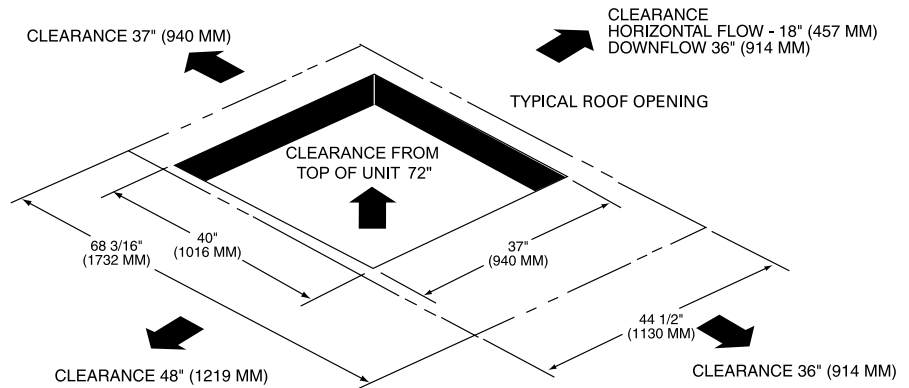

### WSC060 – Roof Curb

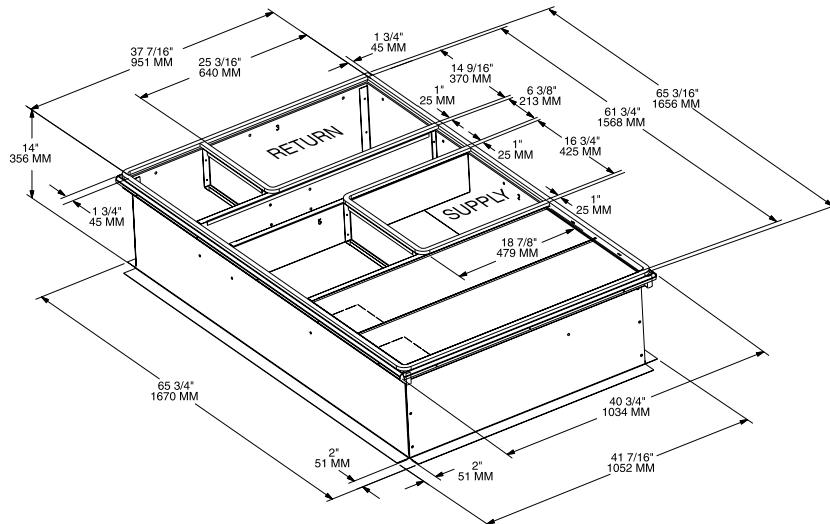

### WSC060 – Downflow Duct Connections – Field Fabricated

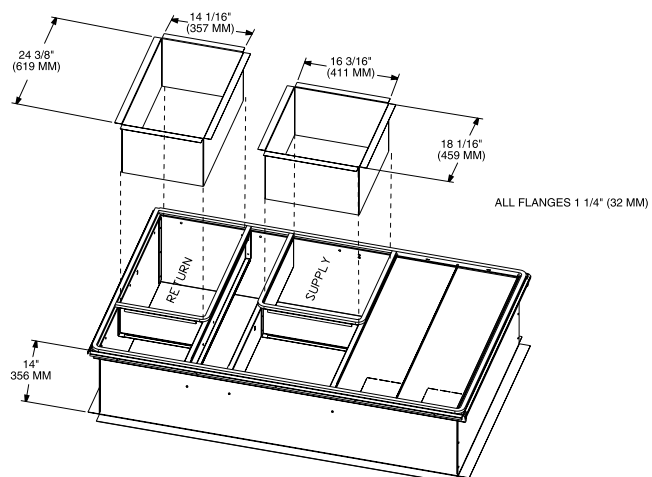



# Dimensional Data

## WSC072-120

All dimensions are in inches/millimeters.

### WSC072 and WSC090

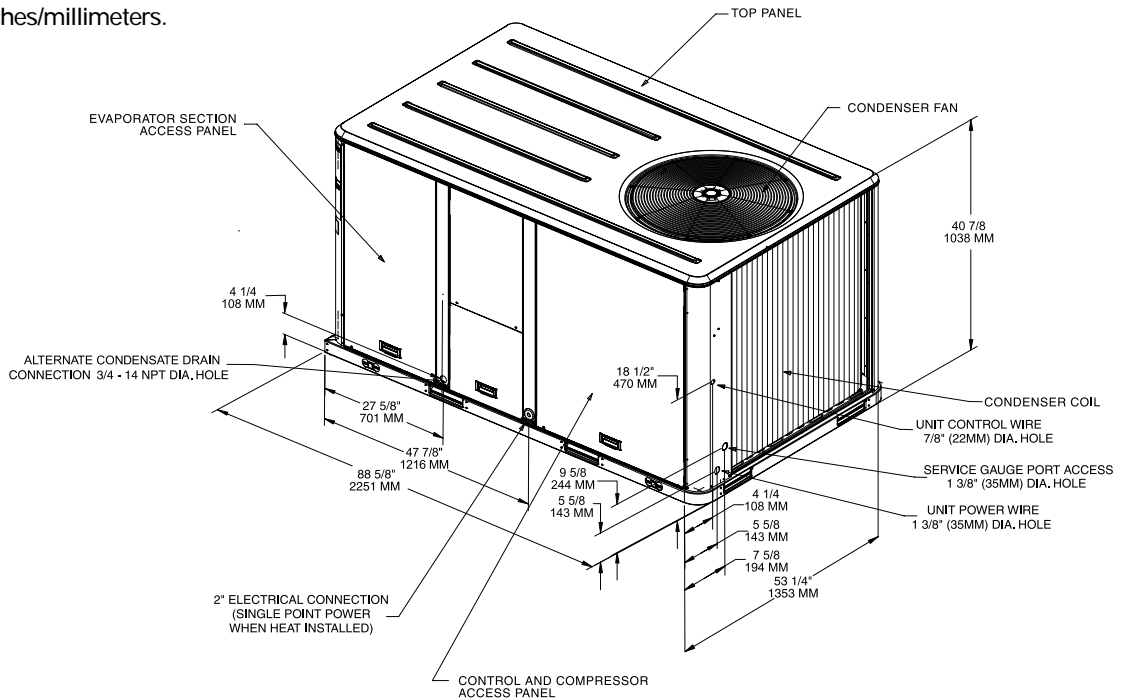

### WSC120

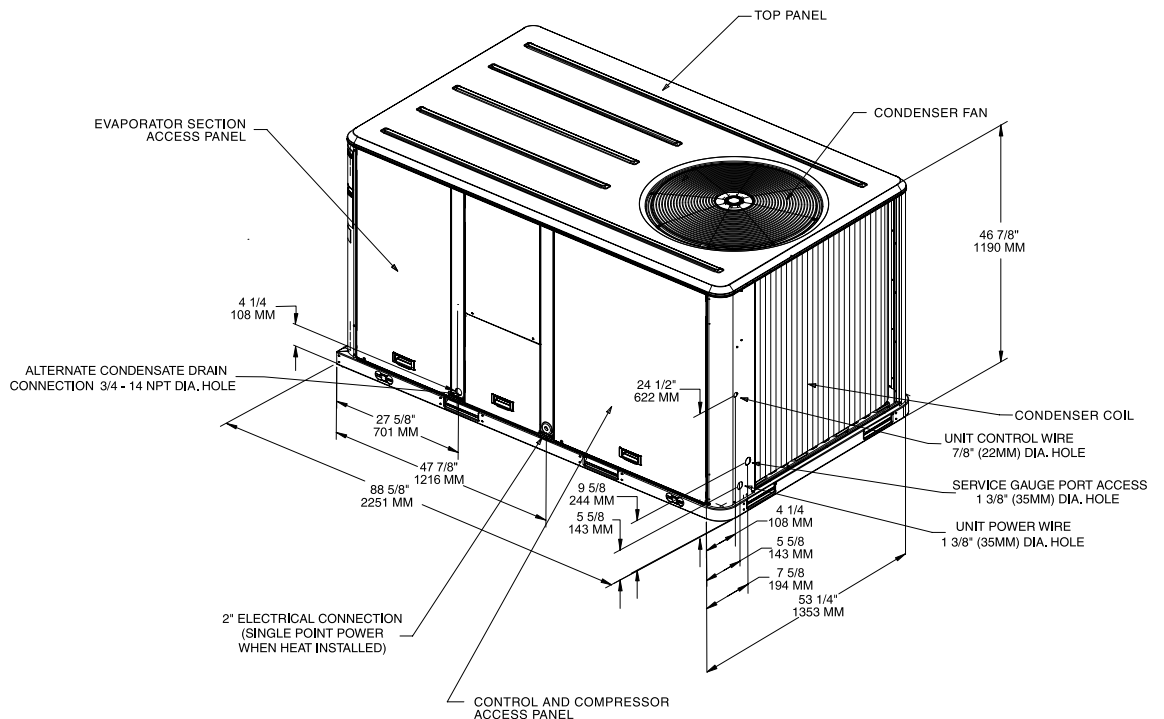

# Dimensional Data

## WSC072-120

All dimensions are in inches/millimeters.

**WSC072-120 – Downflow Airflow Supply and Return**

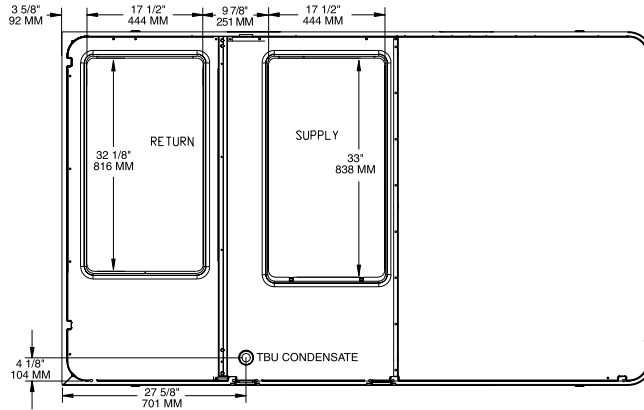

**WSC072-120 – Horizontal Airflow Supply and Return**

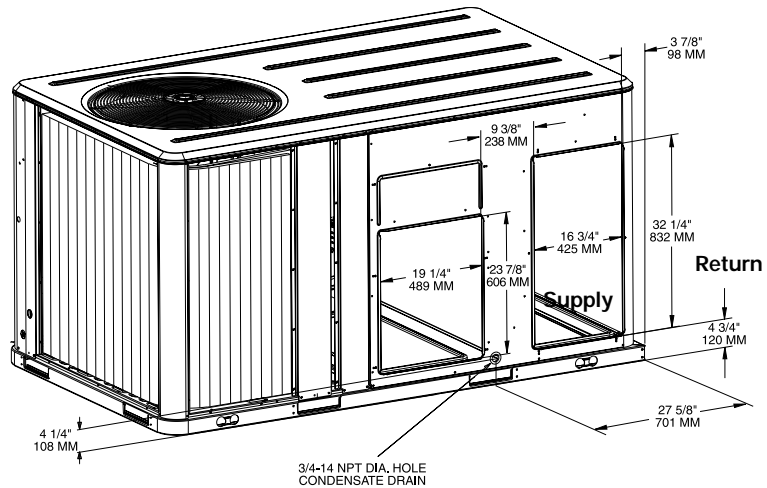

**WSC072-120 – Unit Clearance and Roof Opening**

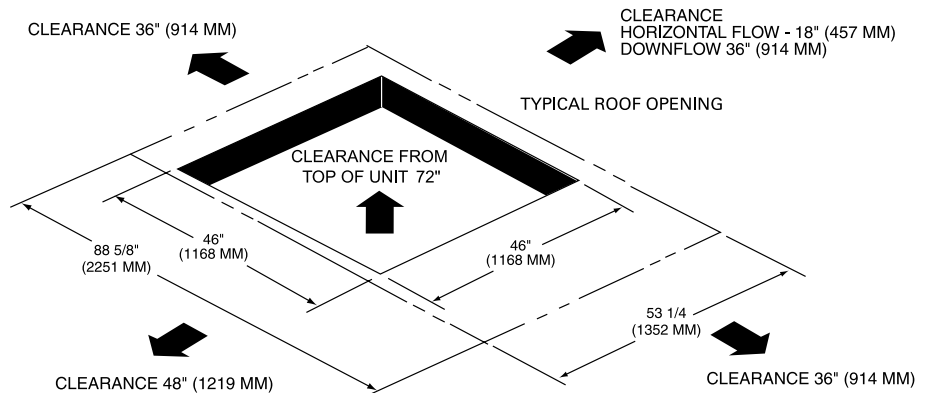

# Dimensional Data

## WSC072-120

All dimensions are in inches/millimeters.

**WSC072-120 – Roof Curb**

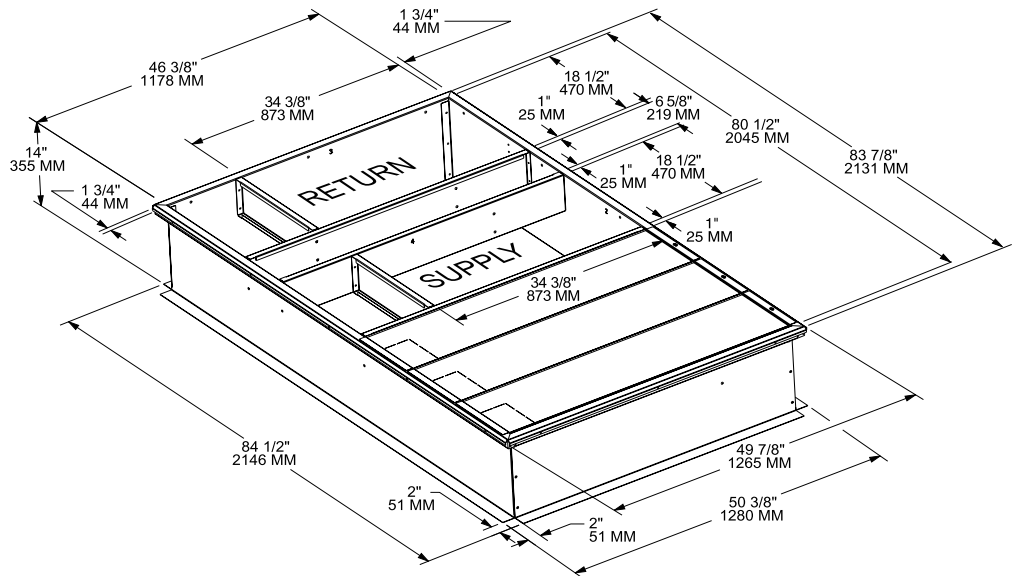

**WSC072-120 – Downflow Duct Connections – Field Fabricated**

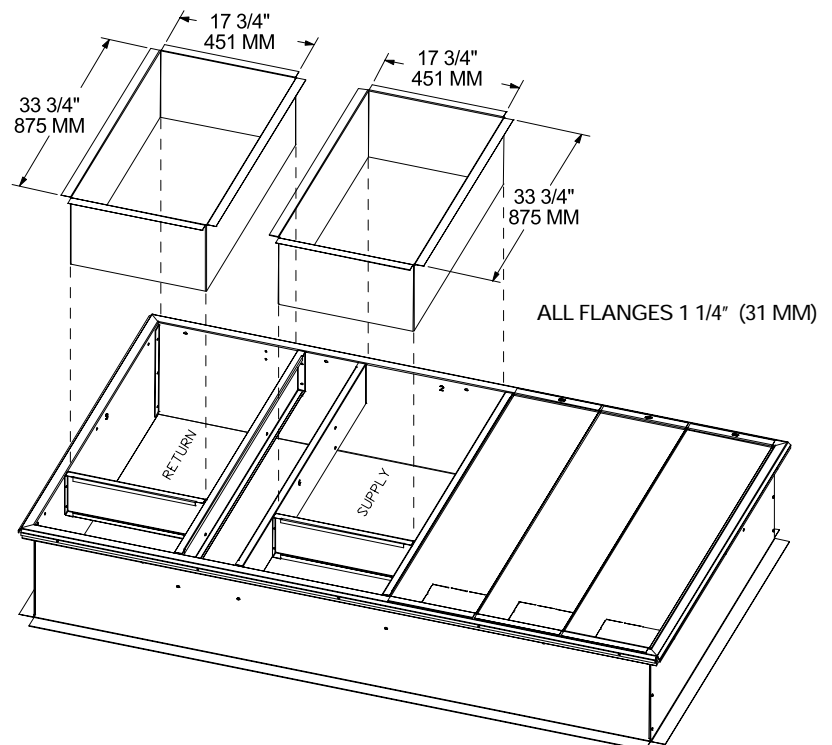

# Dimensional Data

# WSC060 Options/Accessories

All dimensions are in inches/millimeters.

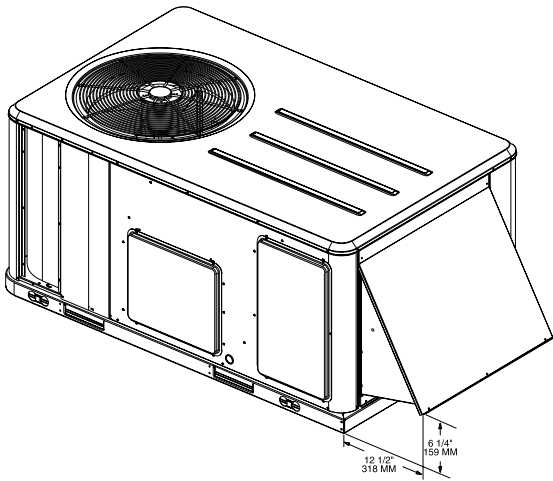

**WSC060 – Economizer, Manual, or Motorized Fresh Air Damper**

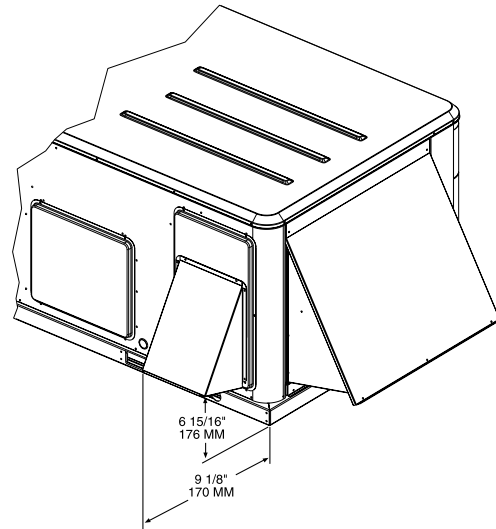

**WSC060 – Barometric Relief Damper**

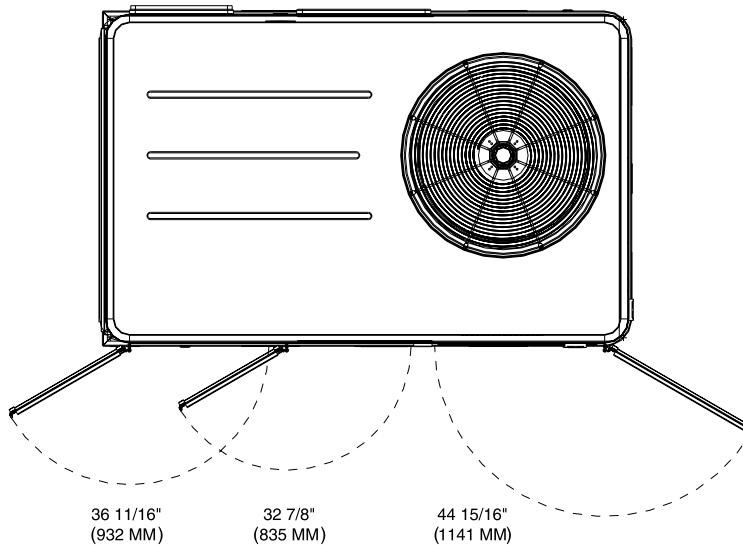

**WSC060 – Swing Diameter for Hinged Doors Option**

# Dimensional Data

## WSC072-120 Options/ Accessories

All dimensions are in inches/millimeters.

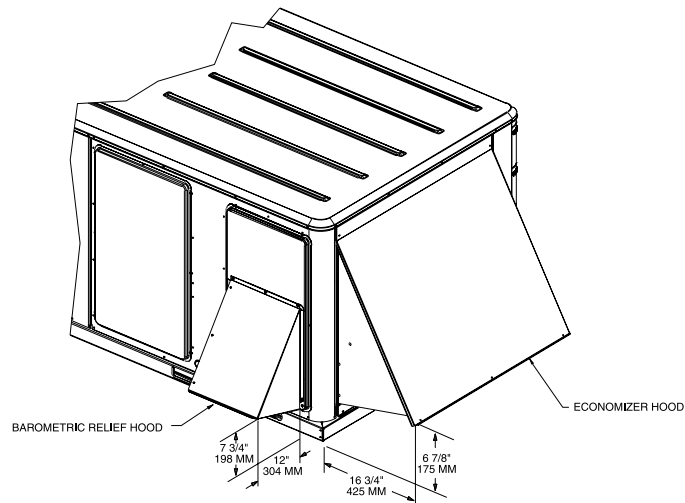

**WSC072-120 – Economizer and Barometric  
Relief Damper Hoods**

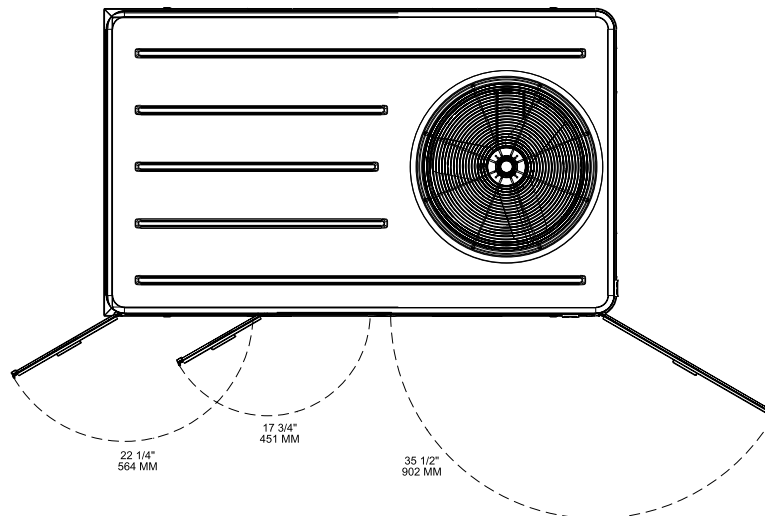

**WSC072-120 – Swing Diameter for Hinged  
Door(s) Option**

# Weights

**Table W-1 – Maximum Unit and Corner Weights And Center Of Gravity Dimensions (SI)**

Unit Model No.	Maximum Weights <sup>2</sup> (kg)		Corner Weights <sup>1</sup> (kg)				Center of Gravity (mm)	
	Shipping <sup>2</sup>	Net <sup>2</sup>	A	B	C	D	Length	Width
WSC060AD,T	266	241	77	58	49	58	790	480
WSC072AD,T	408	368	122	93	66	87	970	560
WSC090AD,T	18	378	128	95	67	88	970	530
WSC120AD,T	484	445	150	115	78	102	970	530

Notes:

1. Corner weights are given for information only. All models must be supported continuously by a curb or equivalent frame support.
2. Weights are approximate.

**Table W-1a – Maximum Unit and Corner Weights And Center Of Gravity Dimensions (IP)**

Unit Model No.	Maximum Weights (lbs)		Corner Weights <sup>1</sup> (lbs)				Center of Gravity (in)	
	Shipping <sup>2</sup>	Net	A	B	C	D	Length	Width
WSC060AD,T	586	532	170	128	107	127	31	19
WSC072AD,T	899	812	269	206	146	191	38	22
WSC090AD,T	921	834	282	210	147	195	38	21
WSC120AD,T	1068	981	330	253	172	225	38	21

Notes:

1. Corner weights are given for information only. All models must be supported continuously by a curb or equivalent frame support.
2. Weights are approximate.

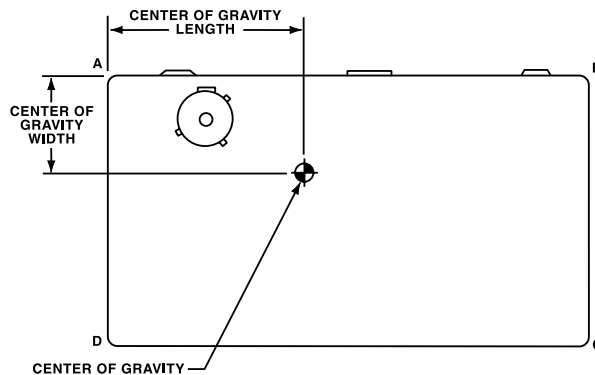

**Table W-2 – Accessory Net Weights<sup>1, 2</sup> (kg)**

Accessory <sup>3</sup>	Net Weights <sup>2</sup>	
	WSC060	WSC072-120
Economizer	12	16
Barometric Relief	3	5
Motorized Outside Air Damper	9	14
Manual Outside Air Damper	7	12
Roof Curb	32	52
Oversized Motor	2	4
Coil Guards	5	9
Hinged Doors	5	5
Electric Heaters	7	14

Notes:

1. Weights for options not listed are < 3 kg.
2. Net weight should be added to unit weight when ordering factory-installed accessories.
3. Some accessories not available on all units.

**Table W-2a – Accessory Net Weights<sup>1, 2</sup> (lbs)**

Accessory <sup>3</sup>	Net Weights <sup>2</sup>	
	WSC060	WSC072-120
Economizer	26	36
Barometric Relief	7	10
Motorized Outside Air Damper	20	30
Manual Outside Air Damper	16	26
Roof Curb	70	115
Oversized Motor	5	8
Coil Guards	12	20
Hinged Doors	10	12
Electric Heaters	15	30

Notes:

1. Weights for options not listed are < 5 lbs.
2. Net weight should be added to unit weight when ordering factory-installed accessories.
3. Some accessories not available on all units.

# Mechanical Specifications

---

## General

The units shall be convertible airflow. The operating range shall be between 46°C and -18°C (115°F and 0°F) in cooling as standard from the factory for all units. All units shall be factory assembled, internally wired, fully charged with R-22, and 100 percent run tested to check cooling operation, fan and blower rotation and control sequence, before leaving the factory. Wiring internal to the unit shall be colored and numbered for simplified identification.

## Casing

Unit casing shall be constructed of zinc coated, heavy gauge, galvanized steel. Exterior surfaces shall be cleaned, phosphatized, and finished with a weather-resistant baked enamel finish. Cabinet construction shall allow for all maintenance on one side of the unit. Service panels shall have lifting handles and be removed and reinstalled by removing only a single fastener while providing a water and air tight seal. All exposed vertical panels and top covers in the indoor air section shall be insulated with cleanable foil faced, fire-retardant permanent, odorless glass fiber material. The base of the unit shall be insulated with 13mm, 16 kg (1/2 inch, 1 pound) density foil-faced, closed-cell material. All insulation edges shall be either captured or sealed. The unit's base pan shall have no penetrations within the perimeter of the curb other than the raised 29mm (1 1/8 inch) high downflow supply/return openings to provide an added water integrity precaution, if the condensate drain backs up. The base of the unit shall have provisions for forklift and crane lifting, with forklift capabilities on three sides of the unit.

## Unit Top

The top cover shall be one piece, or where seams exist, double hemmed and gasket sealed to prevent water leakage. The ribbed top adds extra strength and prevents water from pooling on unit top.

## Filters

25 mm (1 inch), throwaway filters shall be standard on all 5 ton units. The filter rack can be converted to two inch capability. 50 mm (2 inch) filters shall be factory supplied on all 6-10 ton units. Optional 50 mm (2 inch) pleated media filters shall be available.

## Compressors

All units shall have direct-drive, hermetic, scroll type compressors with centrifugal type oil pumps. Motor shall be suction gas-cooled and shall have a voltage utilization range of plus or minus 10 percent of unit nameplate voltage. Internal overloads shall be provided with the scroll compressors. .

## Refrigerant Circuits

Each refrigerant circuit shall have independent fixed orifice or thermal expansion devices, service pressure ports, and refrigerant line filter driers factory-installed as standard. An area shall be provided for replacement suction line driers.

## Evaporator and Condenser Coils

Internally finned, 8mm (5/16 inch) copper tubes mechanically bonded to a configured aluminum plate fin shall be standard. Coils shall be leak tested at the factory to ensure the pressure integrity. The evaporator coil and condenser coil shall be leak tested to 1,375 kPa (200 psig) and pressure tested to 3,100 kPa (450 psig). The condenser coil shall have a patent pending 1 + 1 + 1 hybrid coil designed with slight gaps for ease of cleaning. A reversible, removeable, double sloped condensate drain pan with provision for through the base condensate drain is standard.

## Outdoor Fans

The outdoor fan shall be direct-drive, statically and dynamically balanced, draw-through in the vertical discharge position. The fan motor shall be permanently lubricated and shall have built-in thermal overload protection.

## Indoor Fan

All units shall be belt driven. Units with belt-drive shall have an idler-arm assembly for quick-adjustment of fan belts and motor sheaves. All motors shall be thermally protected. Oversized motors shall be available for high static application.

## Controls

Unit shall be completely factory wired with necessary controls and contactor pressure lugs or terminal block for power wiring. Unit shall provide an external location for mounting a fused disconnect device. Microprocessor controls shall be provided for all 24 volt control functions. The resident control algorithms shall make all heating, cooling, and/or ventilating decisions in response to electronic signals from sensors measuring indoor and outdoor temperatures. The control algorithm maintains accurate temperature control, minimizes drift from set point, and provides better building comfort. A centralized microprocessor shall provide anti-short cycle timing and time delay between compressors to provide a higher level of machine protection.

## Defrost Controls

Adaptive demand defrost shall be provided to permit defrost wherever coil icing conditions begin to significantly reduce unit capacity.



# Mechanical Specifications

## Options/Accessories

**Electric Heaters** – Field-installed electric heat modules shall be available for installation within basic unit. Electric heater elements shall be constructed of heavy-duty nickel chromium elements internally delta connected for 200 volt, wye connected for 380-415 volt. Staging shall be achieved through the unit control processor (UCP). Each heater package shall have automatically reset high limit control operating through heating element contactors. All heaters shall be individually fused from the factory, where required. Power assemblies shall provide single-point connection.

**Roof Curb** – The roof curb shall be designed to mate with the downflow supply and return openings and provide support and a water tight installation when installed properly. The roof curb design shall allow field-fabricated rectangular supply/return ductwork to be connected directly to the curb. Curb shall be shipped knocked down for field assembly and shall include wood nailer strips.

**Economizer** – shall be either field or factory-installed and shall be available with or without barometric relief. The assembly includes fully modulating 0-100 percent motor and dampers, relief, minimum position setting, preset linkage, wiring harness with plug, spring return actuator and fixed dry bulb. The barometric relief damper provide a pressure operated damper that shall be gravity closing and shall prohibit entrance of outside air during the equipment "off" cycle. Solid state enthalpy and differential enthalpy control shall be factory or field-installed options. The factory-installed economizer arrives in the shipping position and shall be moved to the operating position by the installing contractor.

**Remote Potentiometer** – The minimum position setting of the economizer shall be adjusted with this field-installed accessory.

**Reference or Comparative Enthalpy** – Reference or Comparative Enthalpy option shall be available when a factory-installed economizer is ordered.

**Clogged Filter/Fan Failure Switch** – A factory or field-installed dedicated differential pressure switch is available to achieve active fan failure indication and/or clogged filter indication. These indications will be registered with either a zone sensor with status indication lights or an Integrated Comfort™ system.

**Manual Outside Air Damper** – Factory or field-installed rain hood and screen shall provide up to 50 percent outside air.

**Motorized Outside Air Dampers** – Factory or field-installed manually set outdoor air dampers shall provide up to 50 percent outside air. Once set, outdoor air dampers shall open to set position when indoor fan starts. The damper shall close to the full closed position when indoor fan shuts down.

**Oversized Motors** – Factory or field-installed direct drive oversized motors shall be available for high static applications.

**High Pressure Cutout** – Standard in all units.

**Hinged Access Doors** – Sheet metal hinges are available factory-installed on the Filter/Evaporator, Supply Fan/Heat, and the Compressor/Control Access Doors.

**Discharge Air Sensing Kit** – This factory or field-installed option provides true discharge air sensing in heating models. This sensor is a status indicator readable through Tracer™ or Tracker™.

**Black Epoxy Coated Condenser Coil** – The coil provides corrosion protection to condenser coils for seacoast application. The protection is a factory applied thermoset vinyl coating, bonded to normal aluminum fin stock. The uniform thickness of the bonded vinyl layer exhibits excellent corrosion protection in salt spray tests.



# Mechanical Specifications

---

## Control Options

### **COMM3/4 Trane Communications**

**Interface** – An option for a factory or field-installed Trane Communication Interface is available to allow twisted wire pair communication with an Integrated Comfort™ system.

### **Comm-5 LonTalk Communication**

**Interface** – This factory or field-installed option shall be provided to allow the unit to communicate as a Trane Comm-5 device or directly with generic LonTalk Network Building Automation System Controls.

**Zone Sensors** – This field-installed option shall be provided to interface with the micro equipped Precedent and shall be available in either manual, automatic, programmable with night setback, with system malfunction lights or remote sensor options.

**Differential Pressure Switches** – These factory or field-installed options allow for individual fan failure and dirty filter indication. The fan failure switch will disable all unit functions and “flash” the Service LED on the zone sensor. The dirty filter switch will light the Service LED on the zone sensor and will allow continued unit operation.

**Reference Enthalpy Control** – Replaces the dry bulb control with a wet bulb changeover controller which has a fully adjustable set point. Enthalpy control offers a higher level of comfort control, along with energy savings potential, than the standard dry bulb control. This is due to the additional wet bulb sensing capability. This option can be field-installed or factory-installed with the factory-installed economizer.

**Differential Enthalpy Control** – Replaces the standard dry bulb control with two enthalpy sensors that compare total heat content of the indoor air and outdoor air to determine the most efficient air source. This control option offers the highest level of comfort control, plus energy efficiency, available. This option can be field-installed or factory-installed with the factory-installed economizer.







**Trane**  
*A business of American Standard Companies*  
[www.trane.com](http://www.trane.com)

For more information, contact your local district office or e-mail us at [comfort@trane.com](mailto:comfort@trane.com)

---

Literature Order Number	PKGP-PRC004-EN
File Number	PL-UN-000-PKGP-PRC004-EN-0103
Supersedes	New
Stocking Location	Webb/Mason

---

*Trane has a policy of continuous product and product data improvement and reserves the right to change design and specifications without notice.*

## Free Manuals Download Website

<http://myh66.com>

<http://usermanuals.us>

<http://www.somanuals.com>

<http://www.4manuals.cc>

<http://www.manual-lib.com>

<http://www.404manual.com>

<http://www.luxmanual.com>

<http://aubethermostatmanual.com>

Golf course search by state

<http://golfingnear.com>

Email search by domain

<http://emailbydomain.com>

Auto manuals search

<http://auto.somanuals.com>

TV manuals search

<http://tv.somanuals.com>