



## SISTF10xx-141-LR(T)

**10/100Base-TX to 100Base-FX  
Industrial Unmanaged Switch**

### Installation Manual

Rev. A  
5-July-2007



# Table of Contents

Trademark, copyright, and product classification information .....	iii
Trademark.....	iii
Copyright restrictions .....	iii
FCC warning .....	iii
CE Mark .....	iii
About this product and manual .....	iv
Industrial Switch.....	iv
Term/usage.....	iv
About this manual .....	iv
Manual structure .....	iv
Cautions and warnings .....	v
Cautions and warnings.....	v
Cautions.....	v
Warnings.....	vi
Section I .....	1
SISTF10xx-141 Industrial Unmanaged Switch.....	1
In this section .....	1
General description.....	2
Overview .....	2
Features.....	2
SISTF10xx-141 Industrial Unmanaged Switch part numbers .....	3
Standard models.....	3
Package contents .....	4
Package contents.....	4
Physical description .....	5
Physical dimensions.....	5
Front panel.....	5
Bottom panel.....	6
Back panel .....	6
Section II .....	7
Installation .....	7
In this section .....	7
DIN rail mounting .....	8
DIN rail clip.....	8
DIN rail mounting considerations .....	8
DIN rail mounting .....	9
Wall mounting.....	10
Wall mount bracket .....	10
Wall mount bracket install .....	10
Grounding the Industrial Switch.....	11
Wiring considerations.....	11
Industrial Switch grounding .....	11
Connecting power to the Industrial Switch.....	12
Redundant power inputs .....	12
Terminal-block wiring .....	13
Barrel connector interface cable .....	15
Connecting fiber cables .....	16
Fiber cable installation .....	16
Connecting copper cables .....	17
Copper cable installation.....	17
Copper cable configuration .....	17
DIP Switches .....	18
DIP switch position descriptions.....	18
Light Emitting Diodes (LEDs).....	19
LEDs .....	19
Section III: .....	20
Advanced Features .....	20
Introduction .....	20
In this section .....	20

Advanced Features.....	21
AutoCross™.....	21
Auto-Negotiation ( <i>IEEE 802.3u</i> ).....	21
Pause ( <i>IEEE 802.3xy</i> ).....	21
Section IV:.....	22
Cable Specifications.....	22
Introduction.....	22
In this section.....	22
Copper ( <i>RJ-45</i> ) cable specifications.....	23
Copper cabling.....	23
Copper cable specifications.....	23
RJ-45 pinouts.....	23
Fiber cable and optic specifications.....	24
Fiber cable characteristics.....	24
Fiber optic specifications.....	24
Section V:.....	25
Troubleshooting.....	25
Introduction.....	25
In this section.....	25
Troubleshooting problem and corrective action table.....	26
Section VI:.....	27
Contact Us, Warranty, &.....	27
Compliance Information.....	27
Introduction.....	27
In this section.....	27
Contact us.....	28
Technical support.....	28
Live Web chat.....	28
Web-based training.....	28
E-Mail.....	28
Address.....	28
Warranty.....	29
Limited lifetime warranty.....	29
What the warranty does not cover.....	29
Warranty Service.....	29
Who to contact for returns.....	29
How and where to send the returns.....	29
Customer pays non-compliant return costs.....	30
Non-warranty repair costs.....	30
Repaired non-warranty products.....	30
This warranty is your only remedy.....	30
Compliance information.....	31
Compliances.....	31
UL Listed; C-UL Listed ( <i>Canada</i> ).....	31
FCC Regulations.....	31
Canadian Regulations.....	31
European Regulations.....	31
Appendix A:.....	33
Technical Specifications.....	33
SISTF10xx-141-LR(T) specifications, notices, and warnings.....	33
Notices.....	34
Warnings.....	34

## Trademark, copyright, and product classification information

---

**Trademark** All trademarks and registered trademarks are the property of their respective owners.

---

**Copyright restrictions** © 2007 Transition Networks: All rights reserved. No part of this work may be reproduced or used in any form or by any means—graphic, electronic, or mechanical—without written permission from Transition Networks.  
Printed in the U.S.A.

---

**FCC warning**



This equipment has been tested and found to comply with the limits for class A devices, pursuant to part 15 of FCC rules. These limits are designed to provide reasonable protection against harmful interference in a commercial installation. This equipment generates, uses, and radiates radio frequency energy; therefore, if it is not installed and used in accordance with the instructions in this document, could cause harmful interference to radio communications. Operation of this equipment in a residential area is likely to cause harmful interference; the user will be required to correct the interference at the user's own expense.

---

**CE Mark**

**CE** CE Marking (*European Conformity*): This is a Class A product. In a domestic environment, this product could cause radio interference; as a result, the user may be required to take adequate preventative measures.

---

## About this product and manual

---

**Industrial Switch** The SISTF10xx-141-LR(T) Industrial Unmanaged Switch provides four 10/100Base-TX (*RJ-45*) copper connections and a 100Base-FX fiber connection. These switches are hardened devices designed to reliably operate in harsh environments such as those found on factory floors, outdoor enclosures or other hazardous environments.

---

**Term/usage** In this manual, the term “Industrial Switch” (*first letter upper case*) refers to the SISTF10xx-141-LR(T) 10/100Base-TX to 100Base-FX Industrial Unmanaged Switch.

---

**About this manual** This manual provides instructions on how to install, configure, and operate the SISTF10xx-141-LR(T) 10/100Base-TX to 100Base-FX Industrial Unmanaged Switch.

---

**Manual structure** This manual has a beginning table of contents; also, at the beginning of each section there is a table of contents. As you traverse the manual, note the side headings. These side headings make it easier to find specific information. The manual sections are as follows:

Section	Description
I	Industrial Switch general description, ordering information, package contents and physical features/description
II	Installation and operation of the Industrial Switch
III	Advanced features
IV	Cable Specifications
V	Troubleshooting
VI	Contacting Transition Networks, product warranty and product compliance information
Appendix A	Presents product specifications, notices, and warnings

---

## Cautions and warnings

---

### Cautions and warnings

Make sure that you read and understand all content identified by these two symbols:



Cautions and warnings appear here and throughout this manual where appropriate. Failure to read and understand the information identified by the “caution” and “warning” symbols could result in poor equipment performance, damage to equipment, or injury to persons.

---

### Cautions

Cautions indicate the possibility of damage to equipment.

 **CAUTION**

Make sure that the Industrial Switch is mounted with proper space around it for ventilation (*heat dissipation*). Failure to observe this caution could result in damage to the Industrial Switch.

 **CAUTION**

Please exercise caution when using power tools. Do not install this unit in damp or wet locations, or in close proximity to very hot surfaces. Failure to observe this caution could result in damage to the Industrial Switch and cables.

 **CAUTION**

Only qualified persons should install the Industrial Switch. Failure to observe this caution could result in poor performance or damage to the Industrial Switch.

 **CAUTION**

Install the Industrial Switch in an environment where the temperature range will not exceed the stated environmental specifications for the particular model being installed. Failure to observe this caution could result in permanent damage to the Industrial Switch.

 **CAUTION**

DO NOT install the Industrial Switch in areas where strong electromagnetic fields (EMF) exist. Failure to observe this caution could result in poor Industrial Switch performance and data corruption.

 **CAUTION**

The Industrial Switch must be mounted to a well-grounded surface. Failure to observe this caution could result in EMI problems.

 **CAUTION**

When connecting DC power wires to the terminal-block plug, pay close attention to the polarity markings shown near the terminal block of the Industrial Switch. Failure to observe this caution could result in damage to the equipment.

 **CAUTION**

This is a Class A product. In a residential environment, this product could cause radio interference in which case the user may be required to take adequate corrective measures.

---

*Continued on next page*

## ***Cautions and warnings, continued***

---

### **Warnings**

Warnings indicate the possibility of injury to persons.



#### **WARNING**

Be sure to disconnect power before installing and wiring the Industrial Switch. Failure to observe this warning could result in an electrical shock.



#### **WARNING**

Fiber optics: Visible and invisible laser radiation when open: DO NOT stare into the beam, or directly view the beam with optical instruments. Failure to observe this warning could result in an eye injury or blindness.



#### **WARNING**

Use of controls, adjustments or the performance of procedures other than those specified herein may result in hazardous radiation exposure.

---



# Section I

## SISTF10xx-141 Industrial Unmanaged Switch

---

**In this section**

These are the topics:

Topic	See Page
General description	2
SISTF10xx-141 Industrial Unmanaged Switch model numbers	3
Package Contents	4
Physical Description	5

---

## General description

---

### Overview

The SISTF10xx-141 Industrial Unmanaged Switch can help eliminate EMI or RFI issues and help to overcome distance limitations with copper-based cabling by providing a fiber interface to transport data from copper-based industrial networking and communication devices over fiber optic cabling.

Each Industrial Switch can connect to either 10Base-T or 100Base-TX copper ports and provides a 100Base-FX fiber optic connection for links up to 20km. Multiple connector options are offered as well as two distinct operating temperature ranges:

- Standard: 0°C to +60°C (32°F to +140°F)
  - Extended: -40°C to +75°C (-40°F to +167°F)
- 

### Features

The SISTF10xx-141 Industrial Unmanaged Switch has the following features:

- Auto-Negotiation
  - AutoCross™
  - Dual, redundant auto-sensing 12 to 48VDC inputs with reverse polarity protection and over current protection
  - IEEE 802.3x flow control support
    - ▶ Flow control on full-duplex
    - ▶ Back pressure on half-duplex
  - 512KB Embedded memory
  - 1K MAC address table
  - DIN-Rail mounting bracket (installed)
  - Wall mount bracket included
  - DIP-switch to set the fiber port mode of operation – full or half-duplex
  - Barrel connector interface cable included for use with external AC/DC power supply (order separately)
  - IP31 protection metal enclosure
  - Lifetime Warranty
-

## SISTF10xx-141 Industrial Unmanaged Switch part numbers

**Standard models** The part numbers shown in Tables 1 and 2 perform as described in this manual.

**Table 1: Industrial Unmanaged Switch Part Numbers**

**Standard Operating Temperature (0°C to +60°C)**

Part Number	Ports 1-4: 10/100Base-TX	Port 5: 100Base-FX
SISTF1011-141-LR	RJ-45 100 m (328ft)	ST, 1300 nm multimode 2 km (1.2 miles)
SISTF1013-141-LR	RJ-45 100 m (328ft)	SC, 1300 nm multimode 2 km (1.2 miles)
SISTF1014-141-LR	RJ-45 100 m (328ft)	SC, 1310 nm single mode 20 km (12.4 miles)

**Table 2: Industrial Unmanaged Switch Part Numbers**

**Extended Operating Temperature (-40°C to +75°C)**

Part Number	Ports 1-4: 10/100Base-TX	Port 5: 100Base-FX
SISTF1011-141-LRT	RJ-45 100 m (328ft)	ST, 1300 nm multimode 2 km (1.2 miles)
SISTF1013-141-LRT	RJ-45 100 m (328ft)	SC, 1300 nm multimode 2 km (1.2 miles)
SISTF1014-141-LRT	RJ-45 100 m (328ft)	SC, 1310 nm single mode 20 km (12.4 miles)

**Note:** The distances for ports 1 and 2 listed in Tables 1 and 2 are typical maximum distances; the physical characteristics of the network will affect the actual distances.

**Table 3: Optional Accessories (sold separately)**

Part Number	Description
SPS-UA12DHT-xx	External power supply includes: (1) AC/DC power supply, 100-240VAC input, 50-60Hz, 12VDC, 1.5A output, -25°C to +70°C operating temp. (1) Regional specific power cord (1) Barrel connector interface cable

**Note:** Replace the xx in the part number above with one of the following identifiers to match the region where the Industrial Switch will be installed:

NA = North America      JP = Japan      OZ = Australia/New Zealand  
UK = United Kingdom      EU = Europe      SA = South Africa

## Package contents

### Package contents

<u>Quantity</u>	<u>Description</u>
1	10/100BaseTX to 100BaseFX Industrial Unmanaged Switch
1	DIN-Rail mounting bracket (installed)
1	One wall mount plate
6	Screws (for attaching wall-mount bracket)
1	Installation manual CD
1	Barrel connector interface cable
	- For external AC/DC power supply (sold separately)

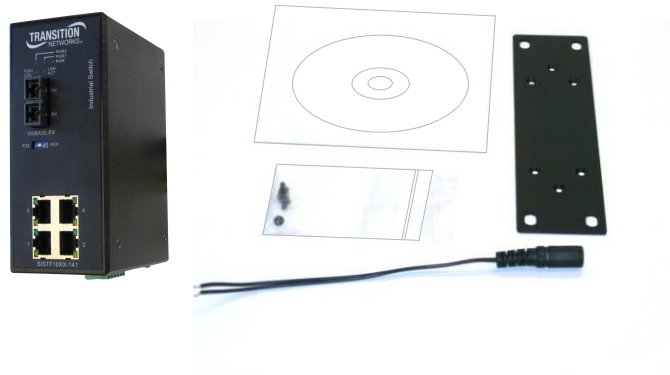

Compare the package contents of your industrial Switch with the standard checklist above. If any item is damaged or missing, please contact Transition Networks Technical Support.

## Physical description

**Physical dimensions**

**Width:** 2.1" [54mm]  
**Height:** 5.3" [135mm]  
**Depth:** 4.1" [105mm]

**Front panel**

The front panel of the Industrial Switch is shown in Figure 1 with corresponding descriptions listed below:

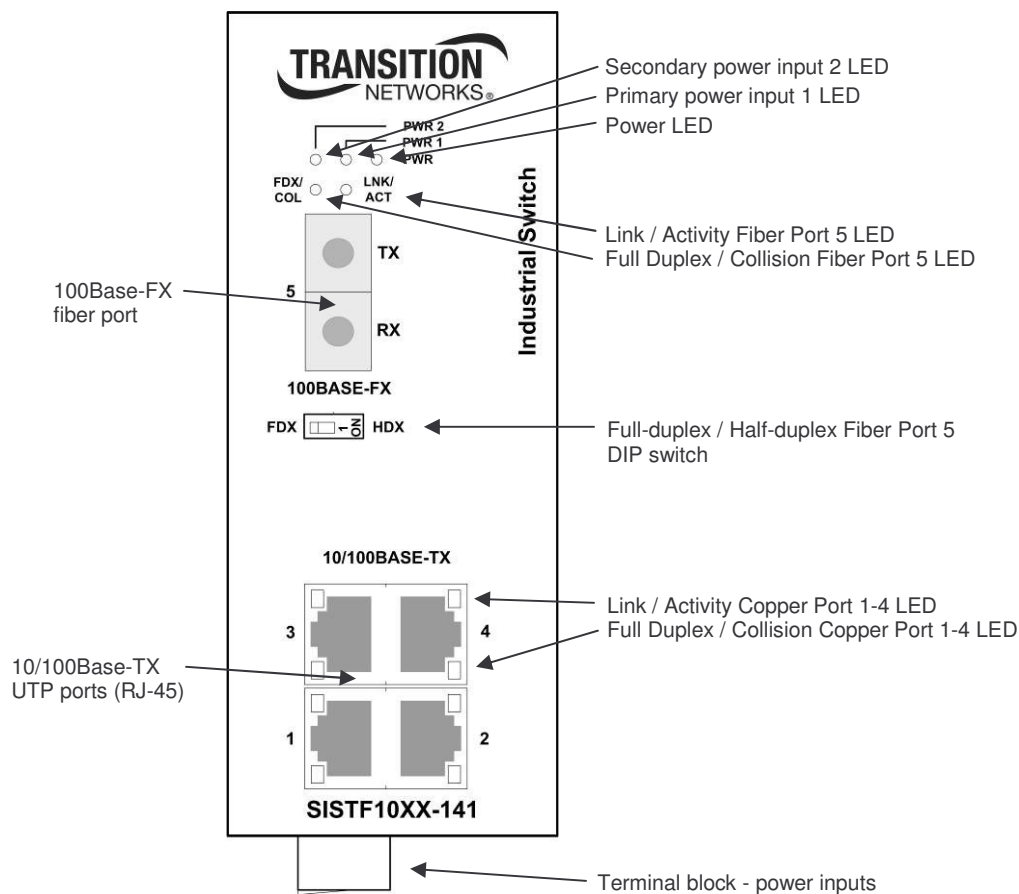

**Figure 1: SISTF10xx-141-LR(T) Industrial Switch (Front View)**

*Continued on next page*

**Physical description, continued**

**Bottom panel**

The bottom view of the Industrial Switch is shown in Figure 2 with corresponding descriptions listed below:

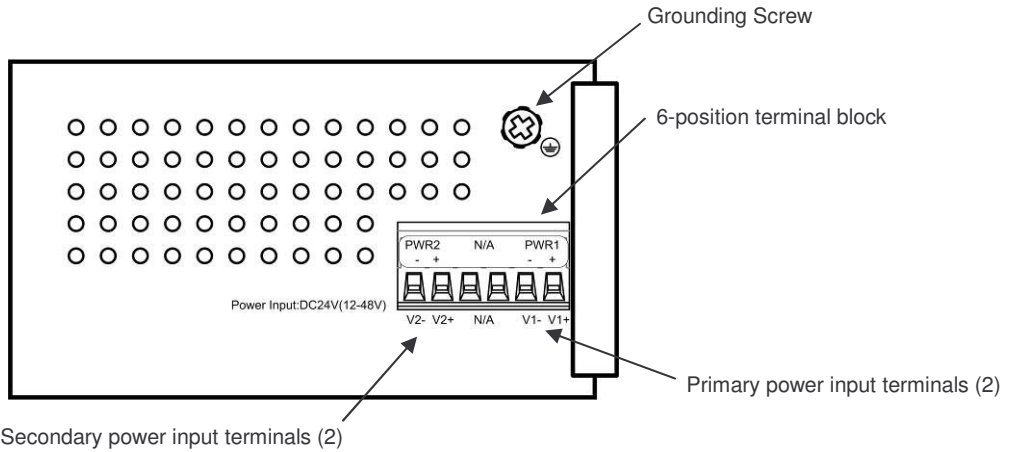

**Figure 2: SISTF10xx-141-LR(T) Industrial Switch (Bottom View)**

**Back panel**

The back view of the Industrial Switch is shown in Figure 3 with corresponding descriptions listed below:

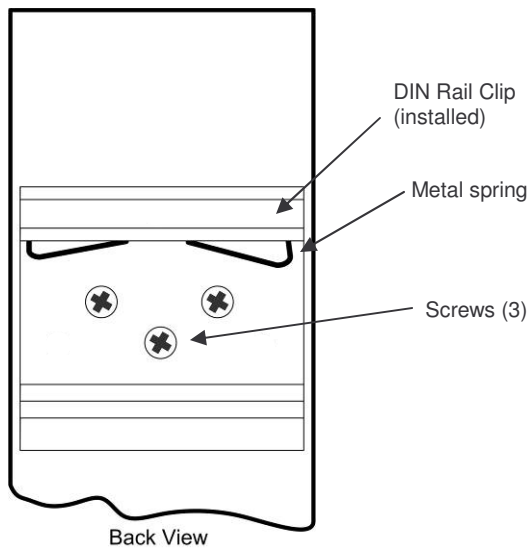

**Figure 3: SISTF10xx-141-LR(T) Industrial Switch (Back View)**

# Section II

## Installation

---

**In this section**

These are the topics:

Topic	See Page
DIN rail mounting	8
Wall mounting	10
Grounding the Industrial Switch	11
Connecting power to the Industrial Switch	12
Connecting fiber cable	16
Connecting copper cable	17
DIP switches	18
Light Emitting Diodes (LEDs)	19

---

## DIN rail mounting

### DIN rail clip

The Industrial Switch includes an aluminum DIN Rail Clip attached to the rear panel. Verify the clip is attached and oriented as pictured in Figure 4 below.

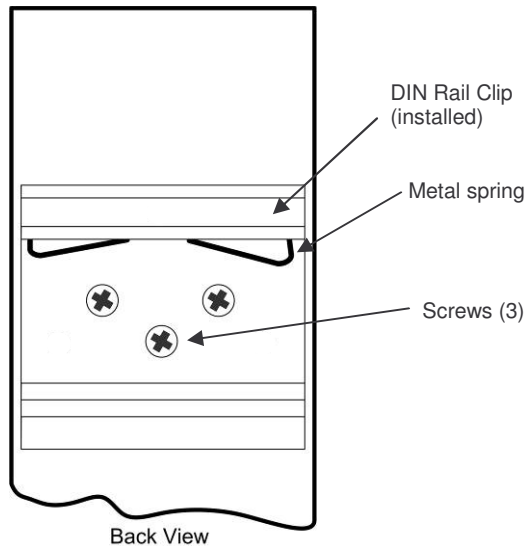

**Figure 4: Mounted DIN Rail Clip**

### DIN rail mounting considerations

Consider the following before mounting the DIN rail to a surface and attaching the Industrial Switch:

- The surface must support at least 635g (1.4 lbs) for the Industrial Switch.
- Do not place heavy objects on the Industrial Switch.

**⚠ CAUTION**

Mount the Industrial Switch with proper spacing around it for ventilation (*heat dissipation*). Failure to observe this caution could result in damage to the Industrial Switch.

**⚠ CAUTION**

Please exercise caution when using power tools. Do not install this unit in damp or wet locations, or in close proximity to very hot surfaces. Failure to observe this caution could result in damage to the Industrial Switch and cables.

*Continued on next page*



***DIN rail mounting, continued***

**DIN rail mounting** To mount the Industrial Switch to the DIN rail, see Figure 5 and do the following:

Step	Action
1.	Align and then position DIN-Rail-clip spring to the top of the DIN rail as shown in Figure 5, step (a).
2.	Press DOWN on the Industrial Switch and then IN to snap it into place on the DIN Rail. See Figure 5, step (b).

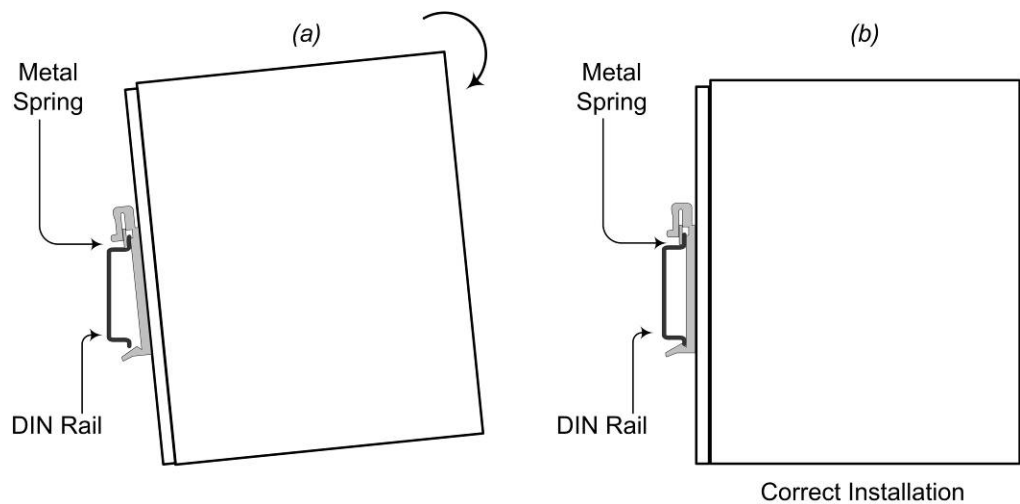

**Figure 5: Industrial Switch Mounting to DIN Rail**

## Wall mounting

### Wall mount bracket

The Industrial Switch includes a wall mount bracket and screws in the contents of the shipping package. The wall mount bracket can be attached to the rear panel of the Industrial Switch to enable mounting to a vertical surface such as the wall of an enclosure. Locate the bracket (1) and screws (6) and follow the steps below to install the bracket on the Industrial Switch.

### Wall mount bracket install

To install the wall mount bracket to the Industrial Switch, see Figure 6 and do the following:

Step	Action
1.	Remove existing screws (3) and DIN-Rail bracket from rear of Industrial Switch.
2.	Locate wall mount bracket and screws (6) from Industrial Switch packaging.
3.	Place bracket in correct orientation as shown and insert and tighten screws to secure bracket to rear of Industrial Switch.
4.	Mount assembled device to a wall per locally accepted practices for anchoring and securing. (Wall mount screws not included.)

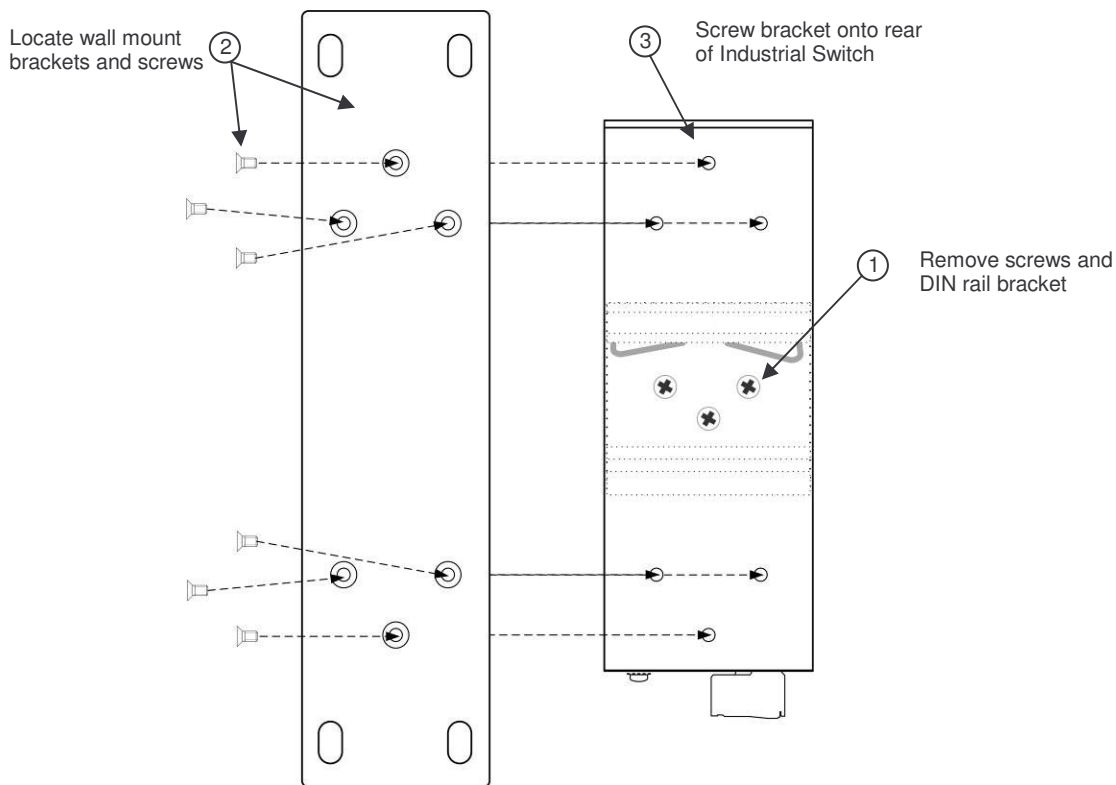

**Figure 6: Installing wall mount bracket to Industrial Switch**

## Grounding the Industrial Switch

### ⚠ CAUTION

Be sure to disconnect the Industrial Switch from the DC power source before installing and wiring the device.

### Wiring considerations

The following wiring considerations are recommended:

- Signal lines must not be directly connector to outdoor wiring.
- Use separate paths or conduits to route wiring for power and device data cables. To avoid interference, wires with different signal characteristics route separately. If power wiring and device data cables must cross make sure that the wires are perpendicular at the intersection point.
- Use the type of signal transmitted through a wire to determine which wires should be kept separate. The rule of thumb is wiring that shares similar electrical characteristics can be bundled together.
- Keep input and output wiring separated.

### ⚠ CAUTION

The Industrial Switch is intended to be grounded to a well-grounded mounting surface such as a metal plate. Install the grounding wire prior to connecting any other device to the Industrial Switch.

### Industrial Switch grounding

Grounding the Industrial Switch helps limit the effects of noise due to electromagnetic interference (EMI) via proper grounding. Always run the ground connection from the ground screw to a grounding surface before connecting the Industrial Switch to a DC power source. See Figure 7.

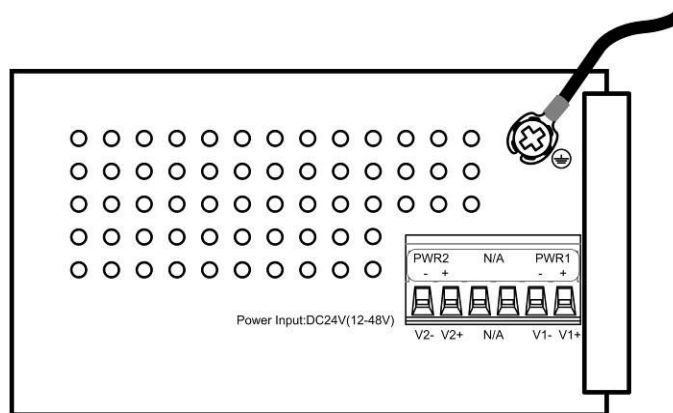

Figure 7: Industrial Switch Ground Screw (*Bottom Panel*)

## Connecting power to the Industrial Switch

### Redundant power inputs

The Industrial Switch has dual (*redundant*) power inputs capable of auto-sensing the input voltage, while providing over current protection and reverse polarity protection.

The dual power inputs can be connected simultaneously to live DC power sources. See Figure 8. If one power source fails, the other live source acts as a backup, and automatically supplies the Industrial Switch with power.

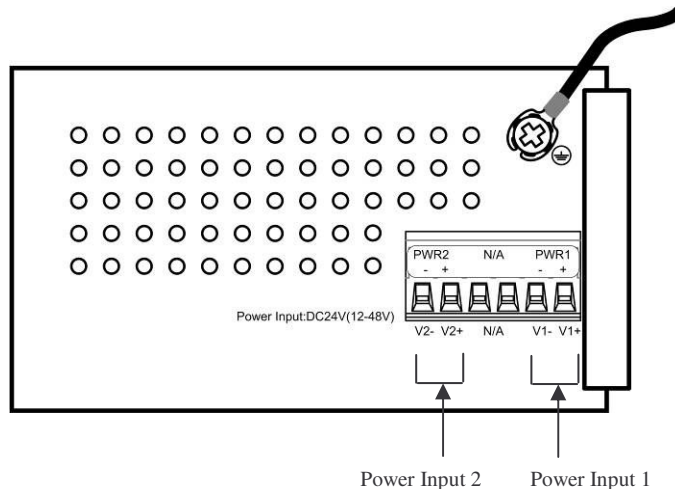

**Figure 8: Redundant Power Connections**

### IMPORTANT

- Power is supplied through an external 12-48 VDC power source. Check the Technical Specification section for details about the DC power input voltage.
- The Industrial Switch does not include a power switch; therefore, plugging a wired and active terminal-block plug into its terminal block will immediately power ON the unit.

### ⚠ CAUTION

Before connecting the Industrial Switch to a DC power source, ensure the power source is stable.

### ⚠ CAUTION

This device is intended to be supplied by a listed power source marked LPS or Limited Power Source, provided with a connector for field wiring terminal.

### ⚠ CAUTION

This device is designed for operation with a safety extra-low voltage (SELV) in compliance with IEC950 / EN60950 / VDE0805 and in compliance with the low voltage directive 73/23/EEC and 93/68/EEC.

*Continued on next page*

## Connecting power to the Industrial Switch, continued

**Note:** The terminal block can accept 12 – 24 AWG wire for power and alarm relay inputs.

### Terminal-block wiring

To wire the 6-position terminal block for redundant power, do the following:

**Note:** The 6-position terminal-block plug is constructed (*keyed*) to mate with the Industrial Switch terminal block. When wiring the plug for power, use the polarity markings next to the terminal block and on top of the plug to ensure proper connection.

Step	Action
1.	Turn the external power source OFF.
2.	Strip the power wires as required.
3.	Insert one stripped power wire into the terminal block plug. Observe polarity. See Figure 9.
4.	Secure the wire using a flathead screwdriver by tightening the contact screw. See Figure 9.
5.	Repeat Steps 3 and 4 until all wires are installed and secured.

Terminal-Block Plug 3 Views

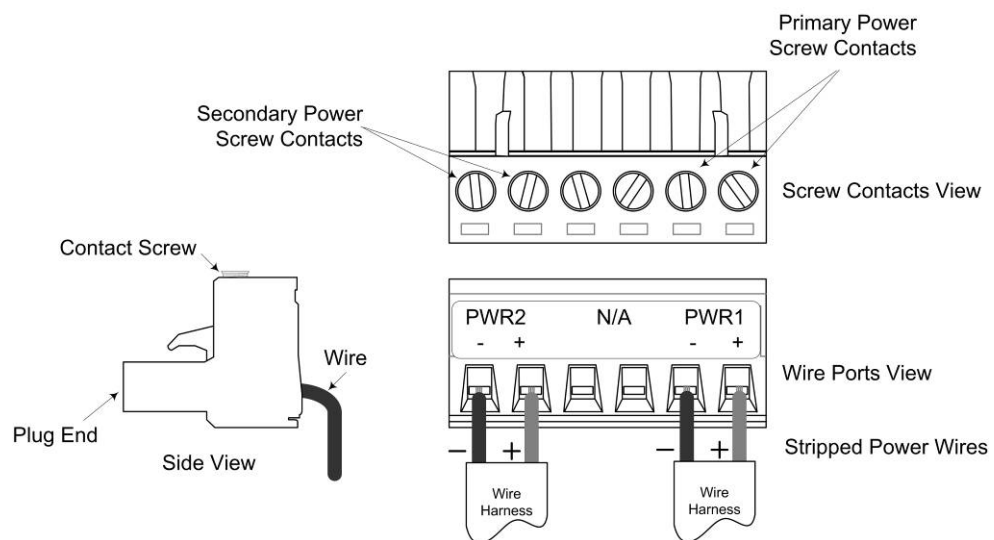

Figure 9: 6-Position Terminal-Block (Primary/Redundant Power Wiring)

Continued on next page

## Connecting power to the Industrial Switch, continued

### Terminal-block wiring (continued)

Step	Action
6.	Insert the terminal block plug into the Industrial Switch's terminal block, as shown in Figure 10.

#### Front View

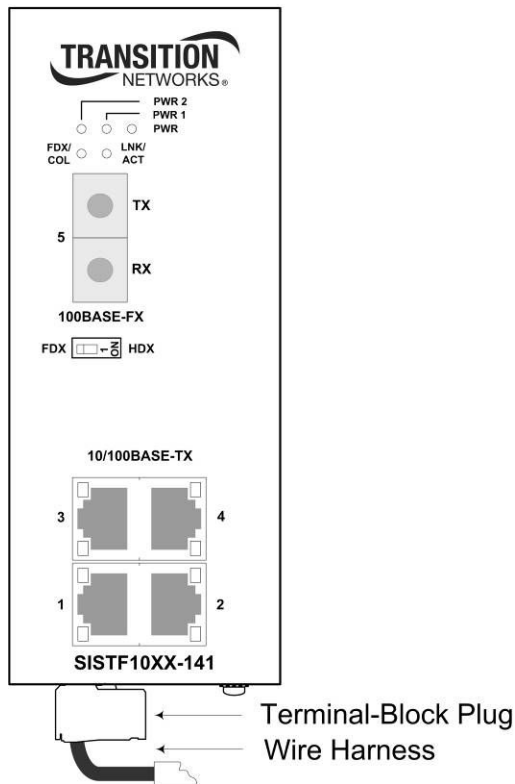

Figure 10: Wired Terminal Block Plug Inserted Into Industrial Switch

7.	Make sure that the DC power source is stable and clean.
8.	Turn ON the power source and the PWR LED should turn ON along with PWR 1 LED and/or PWR 2 LED, depending on whether one or both power supplies are connected and turned ON.

## Connecting power to the Industrial Switch, continued

### Barrel connector interface cable

A barrel connector interface cable is included with the Industrial Switch and can be used to convert the barrel connector output of an external AC/DC power supply over to a wire interface that can then be inserted into the terminal block following the instructions and figure 9, both located on page 13 of this manual.

**Note:** An external AC/DC power supply is not included with the Industrial Switch. Transition Networks offers an accessory power supply that can be purchased separately, if required. Please see optional accessories in the general information section of this manual for ordering information.

### ⚠ CAUTION

The operating temperature of the Industrial Switch, when used in conjunction with an AC/DC power supply will be limited to the lesser operating temperature range of either device.

**For example:** SISTF10xx-141-LRT (-40°C to +75°C operating temp) used with SPS-UA12DHT-xx (-25°C to +70°C operating temp)

**Operating temp for combination is -25°C to +70°C**

Step	Action
1.	Locate the barrel interface cable included in the Industrial Switch packaging.
2.	Strip the power wires as required.
3.	Insert one stripped power wire into the terminal block plug, Observe polarity. See Figure 9 on page 13.
4.	Secure the wire using a flathead screwdriver by tightening the contact screw. See Figure 9 on page 13.
5.	Repeat Steps 3 and 4 until all wires are installed and secured.
6.	Locate an external AC/DC power supply with barrel connector interface and make sure the power supply is not plugged into any power source.
7.	Insert barrel connector into the receptacle on the interface cable. See Figure 11.

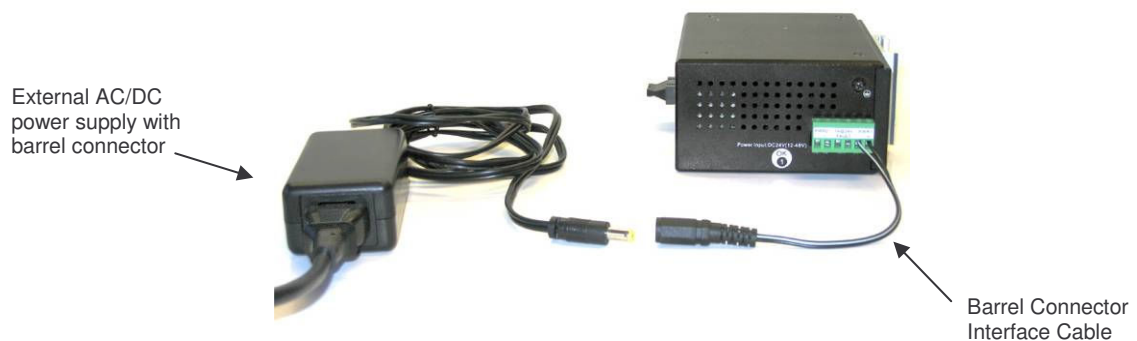

**Figure 11: Barrel Connector Interface Cable with external power supply**

Step	Action
8.	Plug external AC/DC power supply into an external power source.
9.	Turn ON or plug in the external power supply and the PWR LED should turn ON along with PWR 1 LED and/or PWR 2 LED, depending on whether one or both power supplies are connected and turned ON.

## Connecting fiber cables

### Fiber cable installation

When connecting fiber cables to the 100BASE-FX port on the Industrial Switch, make sure the correct type is used: ST or SC.

To install the fiber cables, do the following:

Step	Action
1.	Remove and keep the fiber-port protective dust cover(s).

**Note:** When not connected to a fiber cable, keep the protective cover(s) on the optical ports to protect the optics and keep dust and debris from entering the optical interface.

2.	Check that the fiber connectors on the fiber-optic cabling are clean. If necessary, clean the fiber connectors using locally accepted cleaning procedures.
----	--

**Note:** Dirty fiber connectors on fiber optic cables will impair light transmission quality through the cable and lead to degraded performance on the port.

3.	Connect the fiber cable as shown in Figure 12.
----	--

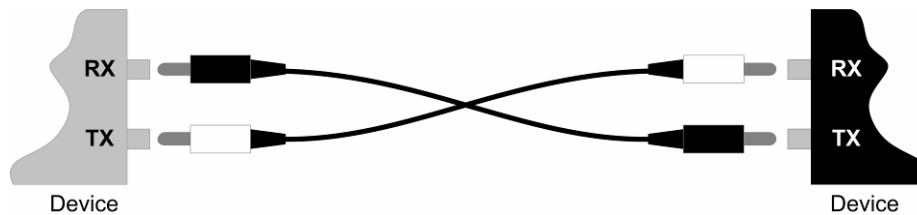

**Figure 12: Fiber Cable Connections**

4.	Check the corresponding fiber port LED on the Industrial Switch to verify the connection—LNK/ACT LED should be lit.
----	---

### Warning

- Visible and invisible laser radiation when open: DO NOT stare into the beam, or directly view the beam with optical instruments. Failure to observe this warning could result in an eye injury.
- Use of controls, adjustments or the performance of procedures other than those specified herein may result in hazardous radiation exposure.



## Connecting copper cables

### Copper cable installation

To connect the copper cable to the Industrial Switch and other equipment, do the following:

Step	Action
1.	Locate or build 10Base-T or 100Base-TX copper cables with male, RJ-45 connectors installed at both ends.
2.	Connect the RJ-45 connector at one end of the cable to the RJ-45 port on the Industrial Switch. See Figure 13 below.
3.	Connect the RJ-45 connector at the other end of the cable to the RJ-45 port on the other device (switch, workstation, PLC, etc.).
4.	Check the copper port LED on the Industrial Switch to verify the connection—LNK/ACT LED should be lit.

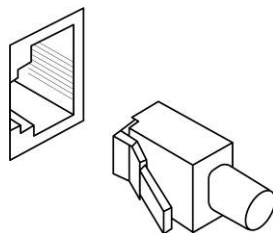

Figure 13: Copper Cable Installation

### Copper cable configuration

Either a straight-through or cross-over cable may be used. See Figure 14.

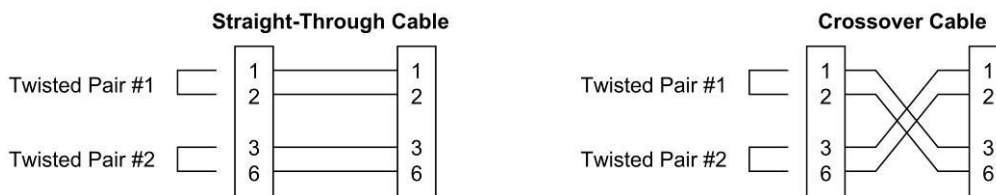

Figure 14: Straight-Through and Crossover Cables

**Note:** The AutoCross™ feature determines the characteristics of the cable connection and automatically configures the unit to link up, regardless of the cable configuration, allowing either straight-through (MDI) or crossover (MDI-X) cables to be used. (Requires no operator intervention.). See Advanced Features section for more information.

## DIP Switches

### DIP switch position descriptions

The Industrial Switch features one DIP switch on the front panel used to configure the fiber port for use in a particular network setting. Figure 15 shows the DIP switch and a chart that explains each setting.

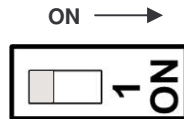

No	Description	Default
1	Half-duplex / Full-duplex Fiber Port 5 (Half-duplex ON, Full-duplex OFF)	OFF

**Figure 15: Dip Switch Setting and Explanation**



### CAUTION

DIP switch changes will not become active until the Industrial Switch is power cycled (turned OFF then ON).

## Light Emitting Diodes (LEDs)

### LEDs

The Industrial Switch has LED indicators located on its front panel. The LEDs present at-a-glance network status, and provide real-time connectivity information. Figure 16 shows the LEDs and a chart that explains the function of each.

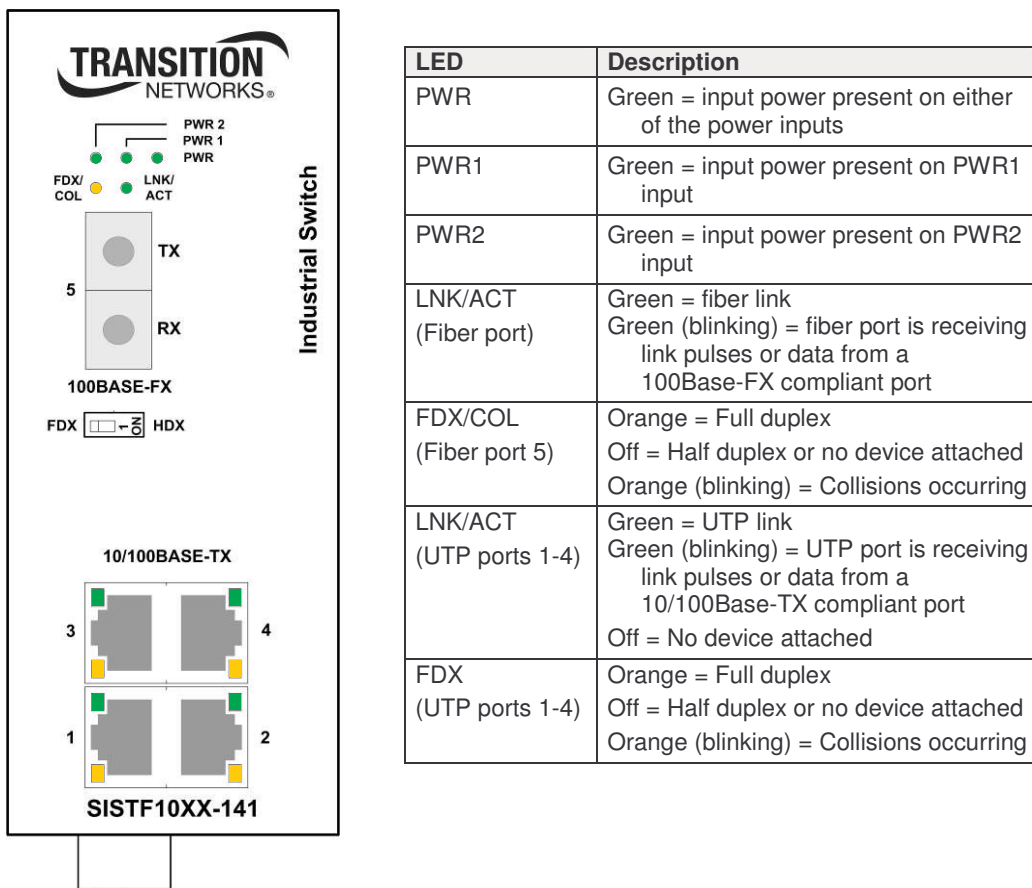

Figure 16: LEDs and Description Chart

# Section III: Advanced Features

---

**Introduction** This section provides an explanation of the advanced features on the Industrial Switch.

---

**In this section** These are the topics:

Topic	See Page
AutoCross™	21
Auto-Negotiation	21
Pause	21

---

## Advanced Features

### AutoCross™

AutoCross™ automatically detects and configures the twisted pair port on the converter to the correct MDI or MDI-X configuration allowing either straight-through (MDI) or crossover (MDI-X) cables to be used – see figure 17. No user intervention is required.

- \* Eliminates an entire category of troubleshooting
- \* No need to identify cable type; straight-through or crossover
- \* No user intervention required to determine correct button / switch settings

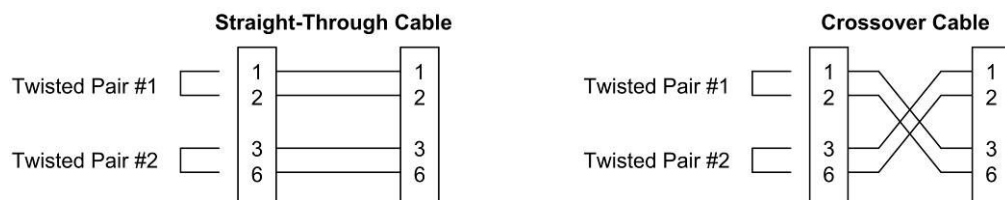

**Figure 17: Straight-Through and Crossover Cables**

### Auto-Negotiation (IEEE 802.3u)

Auto-Negotiation allows devices to perform automatic configuration to achieve the best possible mode of operation over a link. The Industrial Switch will broadcast its speed (10Mbps, 100Mbps) and duplex (half/full) capabilities to other devices and negotiate the best mode of operation between the two devices.

- \* No user intervention required to determine best mode of operation
- \* Optimal link established automatically
- \* Quick and easy installation

**Note:** If the Industrial Switch is connected to a non-negotiating device over the copper link, it will default to 10Mb/s speed, half duplex mode.

### Pause (IEEE 802.3xy)

PAUSE signaling is an IEEE feature that is used to temporarily suspend data transmission between two devices in the event that one of the devices becomes overwhelmed. In the event that a device needs some time to clear network congestion, it will send out a PAUSE signal to the other end device, which will then wait a pre-determined amount of time before re-transmitting the data. Transition's converters will pass PAUSE signaling unhindered; ensuring that the message is delivered to the end device.

- \* PAUSE enabled devices allowed to work properly
- \* Prevents loss of valuable data transmission
- \* Reduces bottlenecks and allows for efficient use of network devices

**Note:** PAUSE signaling is not standardized over fiber media. Transition's Industrial Switches will communicate this signaling over fiber between the converters to pass this signaling on to the other end device.

## Section IV: Cable Specifications

---

**Introduction** This section provides copper and fiber cable specifications.

---

**In this section** These are the topics:

Topic	See Page
UTP cable specifications	23
Fiber cable and optic specifications	24

---

## Copper (RJ-45) cable specifications

**Copper cabling** Shielded twisted-pair (STP) or unshielded twisted-pair (UTP) cabling may be used and can be configured as either Straight-through or crossover – see figure 18.

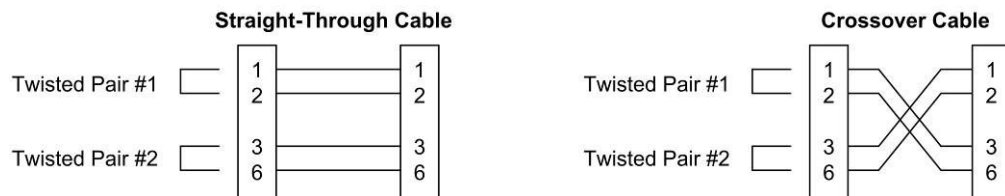

**Figure 18: Straight-Through and Crossover Cables**

**Note:** The AutoCross™ feature determines the characteristics of the cable connection and automatically configures the unit to link up, regardless of the cable configuration, allowing either straight-through (MDI) or crossover (MDI-X) cables to be used. (Requires no operator intervention.). See Advanced Features section for more information.

### Copper cable specifications

Wire category: Category 5 (minimum)  
 Attenuation: 22.0 dB /100m @ 100 MHz  
 Gauge: 24 to 22 AWG  
 Maximum cable distance: 100 meters (328 ft)

### RJ-45 pinouts

Figure 19 shows the RJ-45 connector pin assignment chart.

No	MDI Signal Name	MDI-X Signal Name
1	Receive Data + (RD+)	Transmit Data + (TD+)
2	Receive Data - (RD-)	Transmit Data - (TD-)
3	Transmit Data + (TD+)	Receive Data + (RD+)
6	Transmit Data - (TD-)	Receive Data - (RD-)

**Figure 19: RJ-45 Connector Pin Assignment Chart**

**Note:** The Industrial Switch is configured as a MDI-X device.

## Fiber cable and optic specifications

### Fiber cable characteristics

Cable physical characteristics must meet or exceed IEEE 802.3™ specifications.

Parameter	Specification
Bit Error Rate:	<10 <sup>-9</sup>
Single mode fiber:	9 μm
Multimode fiber:	62.5/125 μm
Multimode fiber:	100/140, 85/140, 50/125 μm

### Fiber optic specifications

The following shows the fiber optic specification:

Fiber Cable	Specifications
<b>SISTF1011-141-LR(T)</b>	1300 nm multimode
Fiber-optic transmitter power:	min: -20.0 dBm    max: -14.0 dBm
Fiber-optic receiver sensitivity:	min: -31.0 dBm    max: 0.0 dBm
Link budget:	11.0dB
<b>SISTF1013-141-LR(T)</b>	1300 nm multimode
Fiber-optic transmitter power:	min: -20.0 dBm    max: -14.0 dBm
Fiber-optic receiver sensitivity:	min: -30.0 dBm    max: 0.0 dBm
Link budget:	11.0dB
<b>SISTF1014-141-LR(T)</b>	1310 nm single mode
Fiber-optic transmitter power:	min: -15.0 dBm    max: -8.0 dBm
Fiber-optic receiver sensitivity:	min: -34.0 dBm    max: 0.0 dBm
Link budget:	19.0 dB

**Note:** The fiber optic transmitters on this device meet Class I Laser safety requirements per IEC-825/CDRH standards and comply with 21CFR1040.10 and 21CFR1040.11.



# Section V: Troubleshooting

---

**Introduction**

This section provides basic troubleshooting information for the Industrial Switch via a problem and corrective action table. The problems are stated in the problem column and the action(s) to take for the problem is stated in the corrective action column. If the corrective measures listed do not correct the problem, contact our 24-Hour Technical Support department at 1-800-260-1312, International: 00-1-952-941-7600.

---

**In this section**

These are the topics:

Topic	See Page
Troubleshooting problem and corrective action table	26

---

## Troubleshooting problem and corrective action table

<b>Problem</b>	<b>Potential Cause</b>	<b>Potential Solution</b>
Industrial Switch does not power up	<ul style="list-style-type: none"> <li>Is the wired terminal-block plug fully inserted into the Industrial Switch?</li> </ul>	<ul style="list-style-type: none"> <li>Wire and insert the terminal-block plug into the Industrial Switch's terminal block – See pages 12-16</li> </ul>
	<ul style="list-style-type: none"> <li>Is the power LED lit?</li> </ul>	<ul style="list-style-type: none"> <li>Check that DC power is at the recommended levels.</li> <li>Contact Technical Support. US/Canada: 1-800-260-1312, International: 00-1-952-941-7600</li> </ul>
No link or activity on the UTP port	<ul style="list-style-type: none"> <li>Is the power LED lit?</li> </ul>	<ul style="list-style-type: none"> <li>Check that the power is turned ON.</li> </ul>
	<ul style="list-style-type: none"> <li>Is the UTP cable properly installed at both ends?</li> </ul>	<ul style="list-style-type: none"> <li>Verify that the cable at both ends is properly inserted into the UTP port</li> <li>Contact Technical Support. US/Canada: 1-800-260-1312, International: 00-1-952-941-7600</li> </ul>
No link or activity on the Fiber port	<ul style="list-style-type: none"> <li>Is the power LED lit?</li> </ul>	<ul style="list-style-type: none"> <li>Check that the power is turned ON.</li> </ul>
	<ul style="list-style-type: none"> <li>Is the Fiber cable properly installed at both ends?</li> </ul>	<ul style="list-style-type: none"> <li>Verify that the cable at both ends is properly inserted into the fiber port</li> <li>Contact Technical Support. US/Canada: 1-800-260-1312, International: 00-1-952-941-7600</li> </ul>

# Section VI: Contact Us, Warranty, & Compliance Information

---

## Introduction

This section explains how to contact Transition Networks via Phone, fax, email, and direct mail. It also explains:

- What the warranty covers
  - Who to contact to return product
  - How and where to return the product
  - Industry standards compliance
- 

## In this section

These are the topics:

Topic	See Page
Contact us	28
Warranty	29
Compliance information	31

---

## Contact us

---

**Technical support**

Technical Support is available 24 hours a day.

United States: 1-800-260-1312

International: 00-1-952-941-7600

---

**Live Web chat**

Chat live via the Web with a Transition Networks Technical Support Specialist.

Log onto [www.transition.com](http://www.transition.com) and click the Transition Now link.

---

**Web-based training**

Transition Networks provides 8-10 seminars per month via live web-based training.

Log onto [www.transition.com](http://www.transition.com) and click the Learning Center link.

---

**E-Mail**

Ask a question anytime by sending an e-mail message to our technical support staff at: [techsupport@transition.com](mailto:techsupport@transition.com)

---

**Address**

Transition Networks

6475 City West Parkway

Minneapolis, MN 55344, U.S.A.

Telephone: 952-941-7600

Toll free U.S.A & Canada: 800-526-9267

Fax: 952-941-2322

---

## Warranty

---

**Limited lifetime warranty**

Effective for products shipped May 1, 1999 and after, every Transition Networks' labeled product will be free from defects in material and workmanship for its lifetime. This warranty covers the original user only and is not transferable.

---

**What the warranty does not cover**

This warranty does not cover damage from accident, acts of God, neglect, contamination, misuse or abnormal conditions of operation or handling, including over-voltage failures caused by use outside the product's specified rating, or normal wear and tear of mechanical components. If the user is unsure of the proper means of installing or using the equipment, contact Transition Networks' free technical support services.

---

**Warranty Service**

Transition Networks will at its option:

- Repair the defective product to functional specification at no charge
  - Replace the product with an equivalent functional product
  - Refund the purchase price of a defective product
- 

**Who to contact for returns**

To return a defective product for warranty coverage, contact Transition Networks' technical support department for a return authorization number (RAN). Transition's technical support department can be reached through any of the following means:

Technical Support is available 24 hours a day:

- Tel: 800-260-1312 x 200 or 952-941-7600 x 200
  - Fax: 952-941-2322
  - Email: techsupport@transition.com
  - Live web chat: Transition Now
  - Voicemail: 800-260-1312 x 579 or 952-941-7600 x 579
  - All messages will be answered within one hour
- 

**How and where to send the returns**

Send the defective product postage and insurance prepaid to the following address:

CSI Material Management Center  
c/o Transition Networks  
6103 Blue Circle Drive  
Minnetonka, MN 55343 U.S.A.

Attn: RETURNS DEPT: Credit Return Authorization (CRA)# or Return Material Authorization (RMA) # \_\_\_\_\_

Failure to protect the product during shipping may void this warranty. The return authorization number must be written on the outside of the carton to ensure its acceptance. We cannot accept delivery of any equipment sent to us without a CRA or RMA number.

---

*Continued on next page*

**Warranty, continued**

---

**Customer pays non-compliant return costs**

The customer must pay the non-compliant product(s) return transportation cost to Transition Networks for evaluation of said product(s) for repair or replacement. Transition Networks will pay for shipping the repaired or replaced in-warranty product(s) back to the customer (*any and all customs charges, tariffs, or/and taxes are the customer's responsibility*).

---

**Non-warranty repair costs**

Before making any non-warranty repair, Transition Networks requires a \$200 charge, plus actual shipping costs to and from the customer. If the repair is greater than \$200, an estimate is issued to the customer for authorization of repair. If no authorization is obtained, or the product is deemed not repairable, Transition Networks will retain the \$200 service charge and return the product to the customer not repaired.

---

**Repaired non-warranty products**

Non-warranted products repaired by Transition Networks for a fee will carry a 180-day limited warranty. All warranty claims are subject to the restrictions and conventions set forth by this document.

Transition Networks reserves the right to charge for all testing and shipping incurred, if after testing, a return is classified as "No Problem Found."

---

**This warranty is your only remedy**

This warranty is your only remedy. No other warranties, such as fitness for a particular purpose, are expressed or implied. Transition Networks is not liable for any special, indirect, incidental or consequential damages or losses, including loss of data, arising from any cause or theory. Authorized resellers are not authorized to extend any different warranty on Transition Networks' behalf.

---

## Compliance information

<b>Compliances</b>	CISPR22/EN5022 Class A + EN55024; EN60950 Class A; FCC Class A; CE Mark
<b>UL Listed; C-UL Listed (Canada)</b>	The following part numbers are UL Listed: SISTF1011-141-LR, SISTF1011-141-LRT, SISTF1013-141-LR, SISTF1013-141-LRT, SISTF1014-141-LR, SISTF1014-141-LRT.
<b>FCC Regulations</b>	This equipment has been tested and found to comply with the limits for a Class A digital device, pursuant to part 15 of the FCC rules. These limits are designed to provide reasonable protection against harmful interference when the equipment is operated in a commercial environment. This equipment generates, uses, and can radiate radio frequency energy and, if not installed and used in accordance with the instruction manual, may cause harmful interference to radio communications. Operation of this equipment in a residential area is likely to cause harmful interference, in which case the user will be required to correct the interference at the user's own expense.
<b>Canadian Regulations</b>	This digital apparatus does not exceed the Class A limits for radio noise for digital apparatus set out on the radio interference regulations of the Canadian Department of Communications. Le présent appareil numérique n'émet pas de bruits radioélectriques dépassant les limites applicables aux appareils numériques de la Class A prescrites dans le Règlement sur le brouillage radioélectrique édicté par le ministère des Communications du Canada.
<b>European Regulations</b>	<p><b>⚠ CAUTION:</b></p> <p>This is a Class A product. In a domestic environment, this product could cause radio interference in which case the user may be required to take adequate corrective measures.</p> <p>Achtung !</p> <p>Dieses ist ein Gerät der Funkstörgrenzwertklasse A. In Wohnbereichen können bei Betrieb dieses Gerätes Rundfunkstörungen auftreten. In diesem Fall ist der Benutzer für Gegenmaßnahmen verantwortlich.</p> <p>Attention !</p> <p>Ceci est un produit de Classe A. Dans un environnement domestique, ce produit risque de créer des interférences radioélectriques, il appartiendra alors à l'utilisateur de prendre les mesures spécifiques appropriées.</p>

**European  
Regulations,**  
(continued)



In accordance with European Union Directive 2002/96/EC of the European Parliament and of the Council of 27 January 2003, Transition Networks will accept post usage returns of this product for proper disposal. The contact information for this activity can be found in the 'Contact Us' portion of this document.

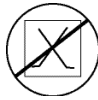

**CAUTION:** RJ connectors are NOT INTENDED FOR CONNECTION TO THE PUBLIC TELEPHONE NETWORK. Failure to observe this caution could result in damage to the public telephone network.

Der Anschluss dieses Gerätes an ein öffentliches Telekommunikationsnetz in den EG-Mitgliedstaaten verstösst gegen die jeweiligen einzelstaatlichen Gesetze zur Anwendung der Richtlinie 91/263/EWG zur Angleichung der Rechtsvorschriften der Mitgliedstaaten über Telekommunikationsendeinrichtungen einschliesslich der gegenseitigen Anerkennung ihrer Konformität.

---



# Appendix A: Technical Specifications

## SISTF10xx-141-LR(T) specifications, notices, and warnings

Parameter	Description
Standards	IEEE 802.3 <sup>TM</sup> , 802.3u <sup>TM</sup> , 802.3x <sup>TM</sup>
Regulatory Compliance for Emissions	CISPR/EN55022 Class A; FCC Class A; CE Mark
Safety Compliance	UL 60950; cUL; CSA C22.2 no 60950
EMI Compliance	EN61000-4-2; EN61000-4-3; EN61000-4-4; EN61000-4-5; EN61000-4-6
Environmental Compliance	IEC60068-2-32 (Free fall) IEC60068-2-27 (Shock) IEC60068-2-6 (Vibration)
Ports	(1) fiber port single mode/multi-mode (4) RJ-45 port
Fiber Optic Specifications	1300 nm Multimode TX power: min: -20.0 dBm    max: -14.0 dBm RX power: min: -31.0 dBm    max: 0.0 dBm Link budget: 11.0dB  1310 nm Single mode TX power: min: -15.0 dBm    max: -8.0 dBm RX power: min: -32.0 dBm    max: 0.0 dBm Link budget: 19.0dB
Max Distance	Fiber (multimode): up to 2km (1.2 miles) Fiber (single mode): up to 20km (12.4 miles) Copper: up to 100 meters (328 ft.)
Max Data Rate	Fiber: 100 Mb/s Copper: 10Mb/s or 100Mb/s
Signals	TxD, RxD, CTS, RTS, DTR, DSR, RI, DCD, GND
MAC Addresses	1K MAC address table
Memory Buffer	512KB
Transfer Rate	14,880 pps [10Mb] or 148,800 pps [100Mb]
Packet Throughput	0.74Mpps @64bytes (4TX + 100FX)
Backplane	1.0 Gbps
Power Consumption	3.3 watts
Ingress Protection	IP31
MTBF	380,973 hours (MIL-HDBK-217F)
Input Power	12 to 48 VDC, 0.2A-0.7A; dual, redundant auto-sensing inputs with reverse polarity and overload current protection
Dimensions	<b>Width:</b> 2.1" [54 mm] <b>Depth:</b> 4.1" [105 mm] <b>Height:</b> 5.3" [135 mm]
Weight	0.64 kg (1.4 lbs)
Shipping weight	0.90 kg (2 lbs)
Standard Operating Temperature (-LR models only)	0°C to +60°C (32 °F to 140°F)
Extended Operating Temperature (-LRT models only)	-40°C to +75°C (-40 °F to 167°F)
Storage Temperature	-40°C to +85°C (-40 °F to 185°F)
Operating Humidity	5% to 90% (non-condensing)
Warranty	Lifetime

***SISTF10xx-141-LR(T) specifications, notices, and warnings, continued***

---

**Notices**

- The information in this user's guide is subject to change. For the most up-to-date information on the SISTF10xx-141-LR(T) Industrial Unmanaged Switch, please refer to the user's guide on-line at: [www.transition.com](http://www.transition.com).
  - Product is certified by the manufacturer to comply with DHHS Rule 21/CFR, Subchapter J applicable at the date of manufacture.
  - **IMPORTANT** Copper based media ports: e.g., Twisted Pair (TP) Ethernet, USB, RS-232, RS422, RS485, DS1, DS3, Video Coax, etc., are intended to be connected to intra-building (*inside plant*) link segments that are not subject to lightening transients or power faults. Copper based media ports: e.g., Twisted Pair (TP) Ethernet, USB, RS-232, RS-422, RS-485, DS1, DS3, Video Coax, etc., are **NOT** to be connected to inter-building (*outside plant*) link segments that are subject to lightening transients or power faults. Failure to observe this caution could result in damage to equipment.
- 

**Warnings**

**WARNING:** Visible and invisible laser radiation when open: Do not stare into the beam or view the beam directly with optical instruments. Failure to observe this warning could result in an eye injury or blindness.



**WARNING:** Use of controls, adjustments or the performance of procedures other than those specified herein may result in hazardous radiation exposure.

---

## Free Manuals Download Website

<http://myh66.com>

<http://usermanuals.us>

<http://www.somanuals.com>

<http://www.4manuals.cc>

<http://www.manual-lib.com>

<http://www.404manual.com>

<http://www.luxmanual.com>

<http://aubethermostatmanual.com>

Golf course search by state

<http://golfingnear.com>

Email search by domain

<http://emailbydomain.com>

Auto manuals search

<http://auto.somanuals.com>

TV manuals search

<http://tv.somanuals.com>